



**MOTORTRONICS**  
*Solid State AC Motor Control*

***XLS SERIES***  
**Solid State Soft Starter**  
**39 - 1250 A**

---

**INSTALLATION & OPERATION  
MANUAL**



# Table of Contents

## **XLS Series Solid State Soft Starter 39 - 1250A**

<b>Chapter 1: Introduction .....</b>	<b>1</b>
1.1 General	
1.2 Specifications and Performance Features	
<b>Chapter 2: Installation .....</b>	<b>2</b>
2.1 Receiving and Unpacking	
2.2 Location	
2.3 Initial Unit Inspection	
2.4 Warning	
2.5 Mounting and Cleaning	
2.6 Power Terminal Wire Range and Tightening Torque	
2.7 Dimensions	
<b>Chapter 3: Motor Overload Protection .....</b>	<b>5</b>
3.1 Thermal Overload Relay	
3.2 Overload Relay	
3.3 FLA Dial Adjustment	
3.4 Manual/Automatic Reset	
3.5 Test for Trip Indication	
<b>Chapter 4: Connections .....</b>	<b>6</b>
4.1 Power Connections	
4.2 Control Connections	
<b>Chapter 5: Adjustments .....</b>	<b>9</b>
5.1 Introduction	
5.2 Acceleration Adjustments	
5.3 Deceleration Adjustments	
<b>Chapter 6: Start-Up .....</b>	<b>12</b>
6.1 Start-up Check List	
6.2 Sequence of Operation	
<b>Chapter 7: Status Indicator LEDs .....</b>	<b>13</b>
7.1 LED Functions	
<b>Chapter 8: Troubleshooting .....</b>	<b>14</b>
8.1 Failure Analysis	
8.2 SCR Testing Procedure	
8.3 Replacing SCR Devices	
8.4 Replacing Printed Circuit Boards	
<b>Chapter 9: Main Control Board .....</b>	<b>20</b>



## Chapter 1 - Introduction

### 1.1 General

The XLS Series solid state reduced voltage soft starter is a six SCR design which features a voltage/current ramp with an anti-oscillation circuit for smooth load acceleration. The SCRs are sized to withstand starting currents of 500% for 60 seconds (compared to 350% for 30 seconds from other manufacturers). The XLS Series features smooth, stepless ramp control which reduces motor inrush current and excessive wear on the mechanical drive train components. In addition to having easy to understand diagnostic lights, the XLS Series can be set up for the ideal starting cycle. Starting voltage, ramp time, current limit, and decel control are standard adjustments on the XLS Series. The starting electrical characteristics of the motor can be matched to the mechanical characteristics of the drive train for controlled acceleration of the load, by simply adjusting the unit's starting torque, ramp time and current limit potentiometers. The XLS Series includes adjustable overload protection, shorted SCR detection and phase loss detection. It is factory wired for 120VAC control voltage (or 240VAC for 415 VAC and 380 VAC units) and three-wire start/stop control. Auxiliary contacts and provisions for interlocking are also included.

### 1.2 Specifications and Performance Features

<b>Type of Load</b>	Three phase AC induction motor	
<b>AC Supply Voltage</b>	208, 240, 380, 415, 480 or 575 (VAC $\pm$ 10%, 50/60 Hz line voltages)	
<b>HP Ratings</b>	39 - 1250 Amps	
<b>Power Circuit</b>	6 SCRs	
<b>SCR Diode Ratings (Peak Inverse Voltage)</b>	<u>Line Voltage</u> 208 to 400	<u>PIV Ratings</u> 1200
	575	1500
<b>Phase Insensitivity</b>	Unit operates with any phase sequence	
<b>Cooling</b>	Convection or fan cooling	
<b>Ambient Operating Temperature</b>	Chassis units: 0° to 50°C (32° to 122°F) Enclosed units: 0° to 40°C (32° to 104°F)	
<b>Control</b>	2 or 3 wire 120 VAC (customer supplied). On 380 and 415V units the control voltage is 240 VAC. Optional CPTs are available.	
<b>Standard Adjustments</b>	Starting Voltage	0 to 80%
	Starting Ramp Time	0 to 60 seconds
	Current Limit	200% to 500%
<b>Decel Option Adjustments</b>	Start Deceleration	0 to 100%
	Deceleration Ramp Time	0 to 30 seconds
	Stop Level	0 to 100%
<b>Current Trip</b>	Fixed 10 times FLA	
<b>Auxiliary Contacts</b>	3 FORM C (N.O., N.C.) 1 programmable relay for "Fault" or "At Speed" 1 programmable "Run" relay 1 Shunt Trip relay	240 VAC, 5 A, 1200 V (maximum)
	1 FORM A (N.O.) Optical Output	240 VAC, 50mA (maximum)
<b>Overload Capacity</b>	115% Continuous 500% 60 Seconds	
<b>Approvals</b>	UL Listed, Canadian UL pending	
<b>Standard Overload</b>	Class 10, 600% $\pm$ 20% for 10 sec. (adjustable)	
<b>Optional Overload</b>	Class 20, 600% + 20% for 20 sec. (adjustable)	
<b>Standard Display / Operator Panel</b>	10 LEDs and all user adjustment potentiometers	
<b>Secondary Display</b>	10 LEDs for visual indication only (Standard on all enclosed unit, optional on panel units)	

## Chapter 2 - Installation

### 2.1 Receiving and Unpacking

Upon receipt of the product you should immediately do the following:

- Carefully unpack the unit from the shipping carton and inspect it for shipping damage (if damaged, notify the freight carrier and file a claim within 15 days of receipt).
- Verify that the model number on the unit matches your purchase order.
- Confirm that the ratings sticker on the unit matches or is greater than the motor's HP and current rating.

### 2.2 Location

Proper location of the XLS Series is necessary to achieve specified performance and normal operation lifetime. The XLS Series should always be installed in an area where the following conditions exist:

- Ambient operating temperature:  
Chassis unit: 0 to 50°C (32 to 122°F)  
Enclosed unit: 0 to 40°C (32 to 104°F)
- Protected from rain and moisture
- Humidity: 5 to 95% non-condensing
- Free from metallic particles, conductive dust and corrosive gas
- Free from excessive vibration (below 0.5G)
- Open panel units must be mounted in the appropriate type of enclosure. Enclosure size and type must be suitable to dissipate heat generated by the soft starter. Contact factory for assistance in sizing enclosures.

### 2.3 Initial Unit Inspection

- Make a complete visual check of the unit for damage which may have occurred during shipping and handling. Do not attempt to continue installation or start up the unit if it is damaged.
- Check for loose mechanical assemblies or broken wires which may have occurred during transportation or handling. Loose electrical connections will increase resistance and cause the unit to function improperly.
- Prior to beginning the installation, verify that the motor and XLS unit are rated for the proper amperage and voltage.

### 2.4 Warning!



***Do not service equipment with voltage applied! The unit can be the source of fatal electrical shocks! To avoid shock hazard, disconnect main power and control power before working on the unit. Warning labels must be attached to terminals, enclosure and control panel to meet local codes.***

### 2.5 Mounting and Cleaning

When drilling or punching holes in the enclosure, cover the electrical assembly to prevent metal filings from becoming lodged in areas which can cause clearance reduction or actually short out electronics. After work is complete, thoroughly clean the area and reinspect the unit for foreign material. Make sure there is sufficient clearance (six inches) all around the unit for cooling, wiring and maintenance purposes. To maximize effective air flow and cooling, the unit must be installed with its heat sink ribs oriented vertically and running parallel to the mounting surface.



#### Warning!

**Remove all sources of power before cleaning the unit.**

In dirty or contaminated atmospheres the unit should be cleaned on a regular basis to ensure proper cooling. Do not use any chemicals to clean the unit. To remove surface dust use 80 to 100 psi, clean, dry compressed air only. A three inch, high quality, dry paint brush is helpful to loosen up the dust prior to using compressed air on the unit.

### 2.6 Power Terminal Wire Range and Tightening Torque

Model Number	Max Amps	Max HP				KW	
		208V	230V	480V	600V	230V	400V
XLS-39	39	-	-	25	30	11	18.5
XLS-48							
XLS-62	62	15	20	40	50	15	30
XLS-78	78	20	25	50	60	22	37
XLS-92	92	25	30	60	75		45
XLS-120	120	30	40	75	100	30	55
XLS-150	150	40	50	100	125	45	75
XLS-180	180	50	60	125	150	55	90
XLS-220	220	60	75	150	200		110
XLS-288	288	75	100	200	250	75	132
XLS-360	360	100	125	250	300	110	160
XLS-414	414	125	150	300	350		200
XLS-475	475	-	-	350	400	132	250
XLS-550	550	150	200	400	500	160	
XLS-718	718	200	250	500	600	200	315
XLS-862	862	250	300	600	700		400
XLS-1006	1006	300	350	700	800		
XLS-1150	1150	350	400	800	900		
XLS-1200	1200	400	450	900	1000		
XLS-1250	1250	450	500	1000	1125		

Model Number	Wire range	Torque lbs/in
XLS-39	#18 - #4	20
XLS-48		
XLS-62	#14 - #4	50
XLS-78		
XLS-92	#14 - #1/0	50
XLS-120		
XLS-150	#6 - 250 kcmil	325
XLS-180		
XLS-220	(2) #6 - 250 kcmil	325
XLS-288		
XLS-360	(2) #2 - 250 kcmil	375
XLS-414		
XLS-476		
XLS-550		
XLS-718	(3) #2 - 600 kcmil	375
XLS-862		
XLS-1006		
XLS-1150	(4) 300 kcmil - 800 kcmil	500
XLS-1200		
XLS-1250		

**Note: All wiring must be sized according to NEC standards.**

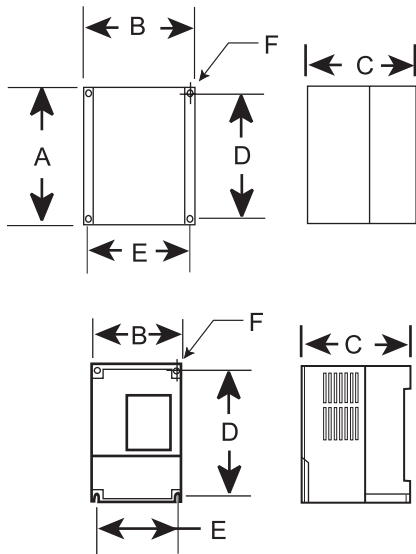

Enclosure	Model Number	Overall Dimensions			Mounting Dimensions		
		A	B	C	D	E	F
PANEL	XLS-6 to XLS-32	12.8	10.9	5.5	12.3	10.3	0.28
	XLS-39 to XLS-120	16.5	10	10	15.9	9	0.28
	XLS-150 to XLS-180	20	20.1	12	18.5	17.5	0.44
	XLS-220 to XLS-288	27	20.1	11.2	25.5	17.5	0.44
	XLS-360 to XLS-550	29.5	20.1	11.5	25.5	17.5	0.44
	XLS-718 to XLS-1006	45	33	12.8	43.3	31.3	0.44
	XLS-1150 to XLS-1250	33	33	15.2	31.2	31.2	0.44
NEMA1	XLS-6 to XLS-32	Not Available			Not Available		
	XLS-39 to XLS-120	16.5	10	10	15.9	9	0.28
	XLS-150 to XLS-180	32.3	24.3	13.3	31.3	18	0.44
	XLS-220 to XLS-288	38.3	24.3	13.3	37.3	18	0.44
	XLS-360 to XLS-550	44.3	30.3	13.3	43.3	24	0.44
	XLS-718 to XLS-1006	50.2	36.3	15.5	49.3	30	0.4
	XLS-1150 to XLS-1250	Contact Factory			Contact Factory		
NEMA 4/4X	XLS-6 to XLS-11	11.7	8.9	9	9	8.4	0.28
	XLS-18 to XLS-78	15.7	12.2	10	12	11	0.28
NEMA12	XLS-92 to XLS-120	24	24	12.9	22.5	22.5	0.5
	XLS-150 to XLS-288	36	30	16.9	34.5	28.5	0.5
	XLS-360 to XLS-550	48	36	16.9	46.5	34.5	0.5
	XLS-718 to XLS-1006	72.1	48.1	20	Floor Mounted		
	XLS-1150 to XLS-1250	Contact Factory			Contact Factory		

## Chapter 3 - Motor Overload Protection

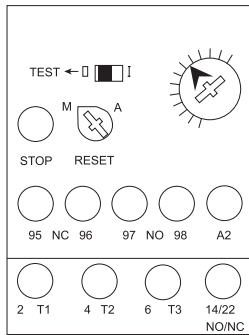

FLA Adjustable Dial

### 3.1 Thermal Overload Relay

The XLS Series provides motor overload protection using an adjustable solid state overload relay. The standard XLS Series is furnished with a Class 10 overload, providing an overload rated at 600% current for 10 seconds. Class 20 overload relays, providing an overload rated at 600% current for 20 seconds, are also available.

### 3.2 Overload Relay

The solid state overload relay has an adjustable FLA range set by a dial. The tripping current corresponds to 110% of the set current.

### 3.3 FLA Dial Adjustment

The overload relay dial must be set to the number from the overload settings label that corresponds to the set current.

$$\text{OVERLOAD RELAY DIAL SETTING} = \frac{\text{FLA}}{\text{CTRATIO}}$$

#### WARNING!



*To provide continued protection against fire or shock hazard, the complete overload relay must be replaced if burnout of the heater element occurs.*

### 3.4 Manual/Automatic Reset

Manual or automatic reset can be selected with the blue button. The appropriate setting is selected by pressing and turning the button.

**Note:** When the automatic restart operation is selected the start warning portion of this label must be placed as to be visible after installation. Label states as follows:

**WARNING: MOTOR CONNECTED TO THIS EQUIPMENT MAY START AUTOMATICALLY WITHOUT WARNING.**

Example of Warning Label

### 3.5 Test for Trip Indication

The switch position indicator also incorporates a test function which, when activated, simulates a tripped overload relay. Both auxiliary contacts are actuated and the switch position is indicated. This test is recommended to ensure that the motor protection is active. Checking, or changing the overload is recommended on major faults.

## Chapter 4 - Connections

### 4.1 Power Connections

Connect appropriate power lines to the unit input terminals marked L1, L2, L3. Avoid routing power wires near the control board. Connect the motor leads to the unit terminals marked T1, T2, T3. Refer to NEC standards for wire length and sizing. Never interchange input and output connections to the unit. This could cause excessive voltage in the control logic circuit and may damage the unit. **Note: Never connect power factor correction capacitors on the load side of the unit. The SCRs will be seriously damaged if capacitors are located on the load side.** The unit cannot be tested without a motor or other test load connected to the load side of the unit. It may be necessary to use a load bank to test the unit without a motor. Note that line voltage will appear across the output terminals if there is no motor or load connected to the unit. In areas where lightning is a significant problem, station-type air gap lightning arrestors should be considered and utilized on the input power source.

**Note:** Some units may have the overload on the load side of the starter.

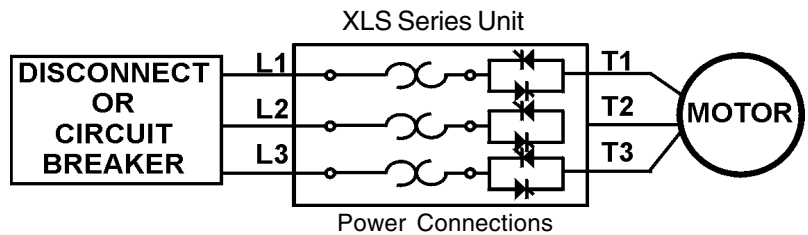

#### 4.1.1 Grounding

Connect the ground cable to the ground terminal as labeled on the unit. Refer to the National Electrical Code for the proper ground wire sizing and be sure that the ground connector is connected to earth ground.

### 4.2 Control Connections

#### 4.2.1 Control Power Connections

Separate 120VAC supply is required (240VAC for 380V and 415V applications). The control voltage should be connected to pins 1 and 6 of TB1. This control voltage must be customer supplied, unless an optional control power transformer (See chart) has been supplied with the unit. On units rated below 100 HP, the TB1 terminal block is located on the main control board.

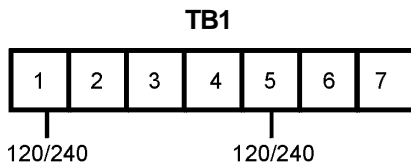

**Note:** If power is used for additional accessory items (Lights, fans, etc.) contact factory for sizing.

XLS Model (by Amps)	Recommended Transformer Sizes		
	Panel	NEMA 1	NEMA 4/12
XLS-150 to XLS-180	50 VA	100 VA	250 VA*
XLS-220	50 VA	100 VA	500 VA*
XLS-288 to XLS-360	250 VA	250 VA	500 VA*
XLS-414 to XLS-550	250 VA	250 VA	750 VA*
XLS-718 to XLS-862	500 VA	500 VA	1 KVA*
XLS-1006 to XLS-1150	500 VA	750 VA	1.5 KVA*
XLS-1200 to XLS-1250	500 VA	750 VA	1.5 KVA*

Recommended Transformer Sizes for Control Power

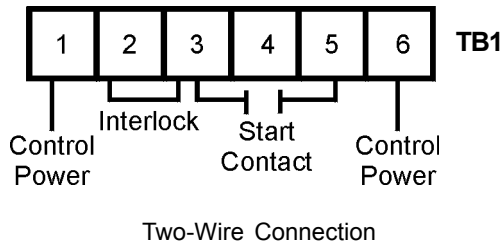

#### 4.2.2 Two-Wire Connection

An alternate connection for unattended operation replaces start/stop push buttons by connecting a maintained contact closure between pins 3 and 5 on TB1. When the maintained contact is used for start/stop it is necessary to set the overload relay to the manual reset position. This will prevent the motor from restarting if the thermal overload trips and then cools off (refer to Chapter 9 for 120 VAC connections and interlocks). **Note: When two-wire connection method is used, the start circuit must be interlocked to prevent automatic restart when either of the two protective devices (overload or thermostat) reset. Thermostats always automatically reset on cool down.**

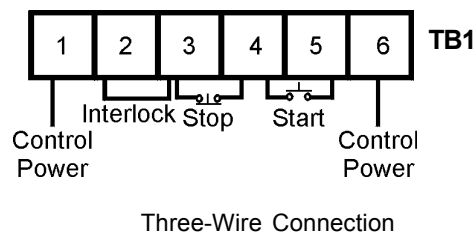

#### 4.2.3 Three-Wire Connection

For standard 3-wire control connect 120VAC (or 240VAC for 415V and 380V applications) to pins 1 and 6 of TB1. Connect N.C. (normally closed) stop button between pins 3 and 4 of TB1. Connect N.O. (normally open) start button between pins 4 and 5 of terminal block TB1.

#### 4.2.4 Resetting Faults

To reset faults, remove the control power for two seconds to clear the fault condition. The unit will also accept a remote reset command via a N.O. dry contact at TB5 located on the main control board, or press the reset button SW2 located near TB5. See Chapter 9 for the main control board layout. Check the unit to ensure that the fault has been corrected before reenergizing unit.

#### 4.2.5 Relay Contacts

All the relay contacts are FORM C common (N.O., N.C.), except the optical triac output. Motortronics recommends fusing all contacts with external fuses. TB2 is the terminal block for all external contacts. Each contact is explained in the following sections. See Chapter 9 for main control board layout.

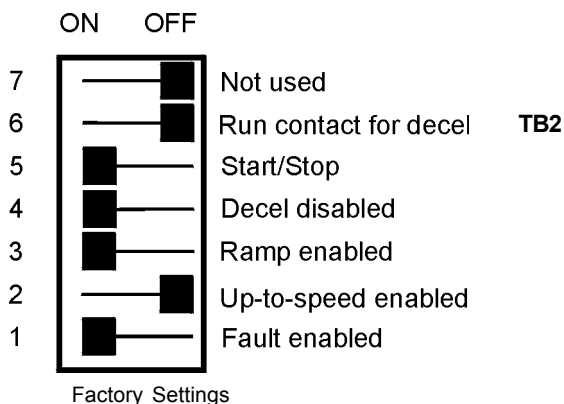

240 VAC  
5 A  
1200 VA

240 VAC  
5 A  
1200 VA

240 VAC  
5 A  
1200 VA

Optical Triac  
Driver  
240 VAC  
50 mA



#### WARNING!

**To make changes in the dip switch settings, the front cover of the unit may need to be removed. Do not make adjustments with power applied to the unit, serious injury may result. Do not use a screwdriver or other tool to make adjustments, damage to the unit may result.**

#### 4.2.6 Programmable Relay

The XLS includes a programmable relay on TB2 which is located on the main control board. The relay is rated for 240 VAC, 5 A and 1200 VA. The relay responds to either a fault condition or an up-to-speed condition. For the relay to act as a fault relay, turn dip switch 1 (SW1), located on the main control board, "ON" and dip switch 2 "OFF" (Factory Setting). For an up-to-speed contact turn dip switch 1 "OFF" and dip switch 2 "ON". Refer to Chapter 9 for dip switch location. In the up-to-speed mode, the programmable relay can be used to control a bypass contactor, or signal other systems that need to be brought online after the motor has reached full speed.

#### 4.2.7 Run Contacts

Auxiliary contacts are available on TB2. These contacts are rated 240 VAC, 5 A, 1200 VA and are for external use. Auxiliary contacts energize (change state) when the start command is given and de-energize (change back) when stop, or fault, condition occurs. In the decel mode, the run contact can be modified to drop out at the stop command, or to stay latched until the end of the decel command. Dip switch 5 is "ON" and dip switch 6 is "OFF" for normal start/stop mode. To keep the run contact latched until the end of decel, turn dip switch 6 "ON" and dip switch 5 "OFF". The decel mode must be enabled by turning dip switch 4 "OFF". Refer to Chapter 9 for the main control board layout.

#### 4.2.8 Emergency Shunt Trip Relay

The shunt trip relay at TB2 on the main control board will activate when a shunt trip signal is received from the motor's monitoring logic. This relay is rated for 240 VAC, 5 A, 1200 V. This relay can be used in an external shunt trip circuit. Check inrush rating on shunt trip breaker. This relay is not programmable and only operates if current is flowing when the XLS is in the off mode. Refer to Chapter 9 for the main control board layout.

#### 4.2.9 Fault Signal

An optical AC switch triac driver is used for fault indication. This signal energizes with the fault LED. The optical output is rated for 240 VAC, 50 mA (maximum).

## Chapter 5 - Adjustments

### 5.1 Introduction

It is best to operate the motor at its full load starting condition to achieve the proper time, torque and ramp settings. Note that the potentiometers have a turning range of 3/4 revolution. Forcing the potentiometer beyond this range will damage the unit. Initial settings are set to accommodate most motor conditions. **TRY INITIAL SETTINGS FIRST.**

### 5.2 Acceleration Adjustments

The unit is set at the factory with typical starting characteristics that perform well in most applications. When the system is ready to start, try the initial unit settings. If the motor does not come up to speed, increase the current limit setting. If the motor does not start to turn as soon as desired, raise the starting voltage adjustment. The unit has three accel adjustments. Adjustment description and procedures are described as follows:

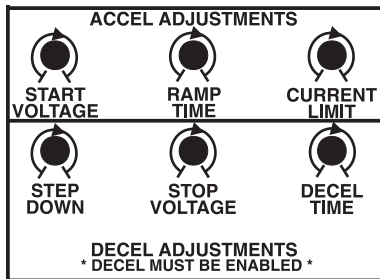

Detail of Operator Interface Module

#### 5.2.1 Starting Voltage Adjustment/Rotation Check

**Factory Setting = 60% of line voltage**

**Range = 0% - 100% of line voltage**

Starting voltage adjustment changes the initial starting voltage level to the motor. Start voltage is increased by rotating the starting voltage potentiometer clockwise. Turn dip switch 3 to the "OFF" position, disabling the ramp function and allowing starting voltage adjustment. This will permit adjustment of the starting voltage without activating the ramp. Turn the starting voltage potentiometer FCCW (fully counter-clockwise). Apply power to the XLS and give the start command. Observe that the motor does not rotate. Slowly increase the start voltage by turning the potentiometer in a clockwise direction until the motor begins to rotate. When the motor begins to rotate, give a stop command and remove both line and control voltage. Reset dip switch 3 for the "ON" position to re-enable the ramp function. The minimum effective starting voltage is now set. **Do not leave dip switch 3 in the off position!**

**Note:** Use this time to check the direction of rotation without full speed operation.

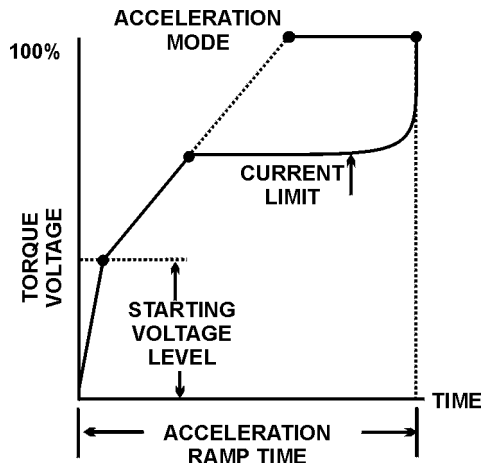

#### 5.2.2 Ramp Time Adjustment

**Factory Setting = 10 sec.**

**Range = 0 - 60 sec.**

Ramp time adjustment changes the amount of time it takes to reach the current limit point or full voltage if the current limit point was not reached. Acceleration time (ramp) can be increased by rotating the ramp time potentiometer in a clockwise direction. The ramp time adjustment is made after the starting torque has been set. Set the ramp time potentiometer by slowly rotating it until the desired ramp time is reached. The unit should be stopped and restarted to see if the desired acceleration time has been achieved

**Note:** Refer to your motor manual for the maximum number of starts allowed by the manufacturer and do not exceed the recommended number.

### 5.2.3 Current Limit Adjustment

**Factory Setting = 350% of unit FLA**

**Range = 200% - 500% of unit FLA**

The current limit adjustment is factory set for 350% of the unit's rating. The range of adjustment is 200% to 500%. The main function of current limit is to cap the peak current. It may also be used to extend the ramping time if desired. The interaction between the voltage ramp and the current limit will allow the soft start to ramp the motor until the maximum current is reached and the current limit will hold the current at that level. The current limit must be set high enough to allow the motor to reach full speed. The factory setting of 350% is a good starting point. **Do not set the current limit too low on variable starting loads, this will cause the motor to stall and eventually cause the system overloads to trip.**

**Note:** If the motor does stall, refer to the motor manufacturer for the proper cooling time.

### 5.3 Deceleration Adjustments

Decel extends the stopping time on loads that stop too quickly, and will provide smooth deceleration until the load stops. Three adjustments optimize the deceleration curve to meet the most demanding requirements. **Try factory settings before adjusting.**

**The unit is shipped from the factory with the decel feature disabled. Turn off dip switch 4 to enable the decel control feature before making any adjustments.** Apply power and adjust the soft start before enabling or modifying the deceleration adjustments. Both acceleration and deceleration adjustments should be made under normal load conditions. The deceleration adjustments are made in the same manner as the starting adjustments; turning the potentiometer clockwise increases the setting, turning the potentiometer counter-clockwise decreases the setting.

#### 5.3.1 Step Down Voltage Adjustment

**Factory Setting = 60% of line voltage**

**Range = 0% - 100% of line voltage**

The step down voltage adjustment eliminates the dead band in the deceleration mode that is experienced while the voltage drops to a level where the motor deceleration is responsive to decreased voltage. This feature allows for an instantaneous drop in voltage when deceleration is initiated.

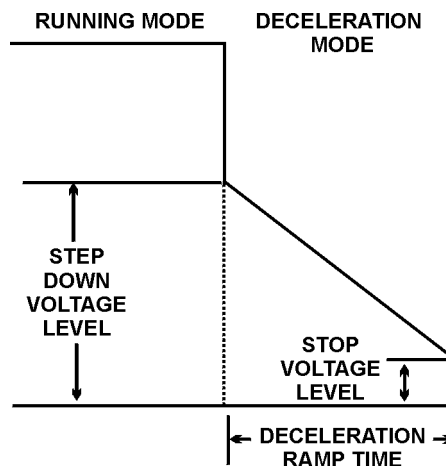

### 5.3.2 Stop Voltage Level

**Factory Setting = 20% of line voltage**

**Range = 0% - 100% of line voltage**

The stop voltage level set point is where the deceleration voltage drops to zero.

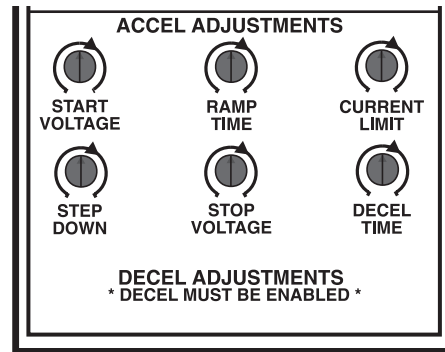

Detail of Operator Interface Module

### 5.3.3 Deceleration Ramp Time

**Factory Setting = 5 sec.**

**Range = 0 - 30 sec.**

The deceleration ramp time adjusts the time it takes to reach the stop voltage level set point. The unit should be restarted and stopped to verify that the desired acceleration time has been achieved.

***Note: Do not exceed the motor manufacturer's recommended number of starts per hour. When calculating the number of starts per hour, a decel curve should be counted as a start curve. For example: recommended number of starts per hour = 6, allowable starts with decel cycle per hour = 3.***

## Chapter 6 - Start-up

### 6.1 Start-up Check List

- Supply voltage matches the rated supply voltage of the unit.
- Horsepower and current ratings of the motor and unit match or the unit is higher rating.
- Initial ramp time and torque adjustments have been checked.
- Power lines are attached to the unit input terminals marked L1, L2 and L3.
- Motor leads are connected to the lower terminals marked T1, T2, and T3.
- Appropriate control power is applied and/or control connections have been made.
- “Power on” light located on the front of the unit turns on when control power is applied.
- The motor area and equipment are clear of people and parts before start-up.
- The thermal overload is set to motor rating.

### 6.2 Sequence of Operation

- Apply control power and check that the “Power On” LED comes on.
- Apply three phase power to the unit. The motor should run only when the start command is applied.
- Apply the start command. The “Run” LED should light up and the motor should begin to accelerate.
- When the motor reaches full speed, the “At Speed” LED comes on.
- If the motor decelerates, or stops, during the acceleration period, hit the stop button immediately and open the disconnect line.

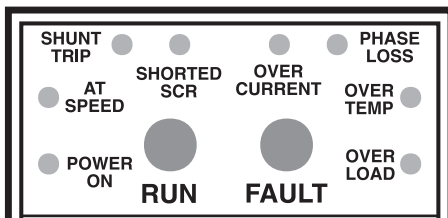

Status Indicator LEDs

If the unit does not follow this operational sequence please refer to Chapter 8 - Troubleshooting.

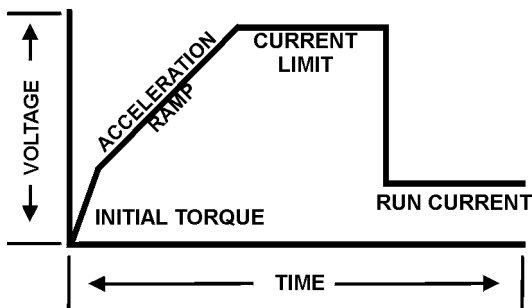

Sequence of Operation

## Chapter 7 - Status Indicator LEDs

### 7.1 LED Functions

The unit has 10 LEDs on the status display.

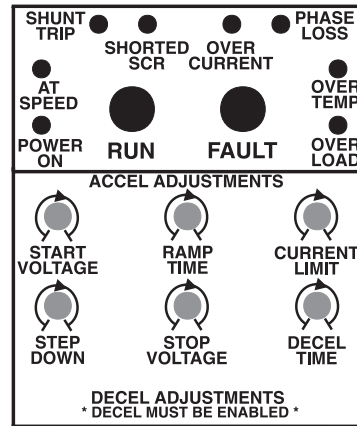

Status Indicator LEDs and operator panel

	LED	STATUS
<b>Green</b>	Run	Indicates that power is provided to the motor. System is online. (This LED will remain lit during the accel/decel modes and anytime there is a possibility of motor rotation.
	Power On	Indicates control power is present.
	At Speed	Indicates the motor is at full speed and power. The SCRs have phased fully on.
<b>Yellow</b>	Shunt Trip	Indicates the starter has two or more power poles shorted and is passing current to the motor while in the off mode. For positive motor protection the "Shunt Trip" relay on the main circuit board must be interlocked with a shunt trip breaker or contactor in front of the unit. Do not re-power the unit without repairing the power poles.
	Shorted SCR	Indicates a shorted SCR was detected in the unit. Refer to section 8.2 for instructions on checking SCRs. This fault will prevent a start command.
	Over Current	Indicates the unit experienced approximately ten times the unit FLA and has shut down from a load failure of some type such as a phase to ground failure or a phase to phase short. The overcurrent trip is fixed at 10 times the full load motor current and is not adjustable. Press the reset button to reset the over current trip. Removing control power for 2 seconds will also reset the trip. Check for faults before reapplying power.
	Phase Loss	This LED indicates that one of the incoming phases was lost while the motor was running.
	Over Temperature	This LED indicates the motor starter has tripped due to over temperature.
	Overload	Indicates the starter's motor overload has tripped. The overload must be reset before the fault can be cleared
<b>Red</b>	Fault	This is a general indication of a fault occurring in the system. This LED lights with another yellow LED to indicate the specific fault.

## Chapter 8 - Troubleshooting

### 8.1 Failure Analysis

Problem	Possible LED Display	Possible Causes	Solution
One of the main fuses blows or circuit breaker opens when the power is applied	Fault and Shunt Trip LEDs: ON	Short circuit between the inputs	Locate and remove the short
		Faulty SCR(s)	Remove power and test the SCR(s). Refer to section 8.2 for SCR Testing procedure.
One of the main fuses blows or circuit breaker opens when the start command is given.	Fault and Overcurrent LEDs :ON Fault and Phase Loss LEDs: ON	Short circuit or ground fault in motor or cabling	Locate and remove the short or the ground
		Phase Loss	Repair the cause of the phase loss
		Branch circuit protection not correctly sized	Verify the correct sizing of the branch circuit protection
		Faulty SCR(s)	Remove power and test the SCR(s). Refer to section 8.2 for SCR Testing procedure.
		Single phase incoming power	Correct the problem with the incoming power
		Faulty main circuit board	Remove power and replace the main circuit board. Refer to section 8.4 for circuit board replacement procedure.
Motor overload trips during start	Fault and Overload LEDs: ON	Overload improperly adjusted	Adjust the overload
		Excessive load on motor	Lighten the load on the motor
		Current limit set too low	Increase the current limit set point
		Incorrect start adjustment	Readjust the starting parameters. Refer to Chapter 5.
Thermostat trips during run	Fault and Over Temp LEDs: ON	Fan(s) not functioning	If the fans have power, remove power and replace the fan(s). If the fans do not have power, find the cause of the power loss and repair
		Heatsink coated with dirt	Remove power and clean the heatsink with high pressure air (80-100 PSI max, clean and dry air)
		Over current on unit	Verify that the running current does not exceed the unit rating.
		Environment temperature over 120°F (ambient temperature for panel version) or over 104°F (ambient temperature for enclosed version)	Place the unit in environment where the ambient temperature is less than 120°F for the panel version or less than 104°F for the enclosed version

Problem	Possible LED Displays	Possible Reasons	Solution
Motor will not start	All LEDs: OFF Power On LED: OFF Start LED: OFF Fault and Phase Loss LEDs: ON Fault and Shorted SCR LEDs: ON	No control voltage applied to control board	Apply control voltage to TB1 pins 1 and 6 on the control board
		Control power transformer failure or CPT fuse failure.	Remove power and replace the power transformer or the CPT fuse
		Start circuit wired incorrectly	Remove power and correct the start circuit wiring
		No start command	Apply the start command
		No 3 phase line voltage	Apply 3 phase line voltage to the unit
		Failure of main circuit board	Replace the main circuit board
		Faulty control logic	Remove power and repair the control logic
		Shorted SCR in starter	Refer to section 8.2 for SCR testing procedures and replace the faulty (shorted) SCR(s)
		Faulty control board	Check the control board for faults and replace the blown fuses.
Motor vibrates / Motor growls	Fault and Phase Loss LEDs: ON	Faulty motor	Check the motor and the motor connections
		Faulty SCR(s)	Remove power and perform the SCR device checks
		Faulty gate/cathode on SCR(s)	Refer to section 8.2 for SCR testing procedures and replace the faulty (shorted) SCR(s)
		Faulty main circuit board	Replace the main circuit board
Extremely unbalanced motor currents during start or run mode	Fault and Phase Loss LEDs: ON	Faulty motor / wiring	Troubleshoot and repair
		Faulty wiring	Troubleshoot and repair / replace wiring
		Faulty main circuit board	Replace the main circuit board
Motor stopped during run	Fault and Over Current LEDs: ON	<b>Warning:</b> This is a serious fault condition. Ensure that the fault condition is cleared on the load before attempting to restart to motor.	
		Load shorted / grounded/ faulted	Remove power and repair
		Faulty main circuit board	Replace the main circuit board
Control circuit fuses blow after control power is applied.	All LEDs: OFF	Short in control circuit	Remove power, locate and remove the short
		Wrong control voltage	Apply the correct voltage to the control board

### 8.2 SCR Testing Procedure

Remove both line power and control power from the unit and lock out. Disconnect any two motor load leads and any two line leads. Disconnect the SCR connections to main control board J5, J6 and J7. Refer the Chapter 9 for the main control board layout. Note the type of color coding of the wires connected to J5, J6 and J7. Motortronics uses two possible configurations. Both configurations have 4 wires going to each plug. The first configuration consists of 4 wires color coded black, yellow, grey and white. The second configuration consists of 4 wires color coded red, white, red, white.

The testing procedure for SCRs is comprised of two separate tests. The first one tests the anode to cathode integrity of the SCR by performing the following ohm checks:

+ Lead	- Lead	Good	Consult factory
L1 Lug	T1 Lug	Greater than 10K ohm	Less than 10K ohm
L2 Lug	T2 Lug	Greater than 10K ohm	Less than 10K ohm
L3 Lug	T3 Lug	Greater than 10K ohm	Less than 10K ohm

The second tests the gate to cathode integrity of the SCR. Place the leads of an ohm meter into the receptacle that was unplugged from the main circuit board. Ohm the pair of wires on one end of the plug. Then ohm the pair of wires on the other end of the plug. The chart below indicates good versus bad readings.

For wire that is color coded black, yellow, gray and white:			
+ Lead	- Lead	Good	Bad
Black	Yellow	Between 5 and 90 ohms	Less than 5, or greater than 90 ohms
Grey	White	Between 5 and 90 ohms	Less than 5, or greater than 90 ohms
For wire that is color coded red, white, red and white:			
Red	White	Between 5 and 90 ohms	Less than 5, or greater than 90 ohms
Red	White	Between 5 and 90 ohms	Less than 5, or greater than 90 ohms

**Note:** If any of the above readings are out of specifications, replace the faulty SCR.

**Note:** The best way to test an SCR is with an SCR Tester and look for leakage current less than the manufacturer specified values.

### 8.3 Replacing SCR Devices

Two types of SCRs are used in the XLS Series depending on the horsepower/amperage rating of the unit. Isolated SCRs are used in smaller units and “hockey puck” type SCRs are used in larger units. (Refer to Chapter 9 for the main control board layout.)

#### 8.3.1 Changing an Isolated SCR

- Remove both line and control power from unit, tag and lock out.



**WARNING!**

**Failure to remove both line and control power before starting this procedure may cause personal injury or death.**

- Label the location of wires connected to the SCR.
- Remove the mounting screws, lugs and associated wiring from the existing SCR.
- Make sure the surface to which the power module mounts is clean and free from dirt, nicks and scratches.
- Apply thermal grease uniformly along the grooved area. Spread the grease thinly (3 mil thick) to completely cover the base of the power module and minimize air pockets. The grease must be free of contamination.
- Replace the screws and tighten down firmly. All mounting screws should be 44lb/in. Units with a maximum amperage rating of up to 48A, should use 26 lbs/in busbar and power lugs. Units with a maximum amperage of 60A - 120A should use 44 lbs/in busbar and power lugs.
- Reconnect all busbars, lugs and wires. Check to make sure the gate and cathode are wired correctly. Use the following chart to verify the wiring of J5, J6 and J7:
- After verifying that all wiring is correctly connected, test the SCR.

Main Circuit Board Pin #	Destination
Pin 1	Load Gate
Pin 2	Load cathode (Output Load Lug)
Pin 5	Line Gate
Pin 6	Line Cathode

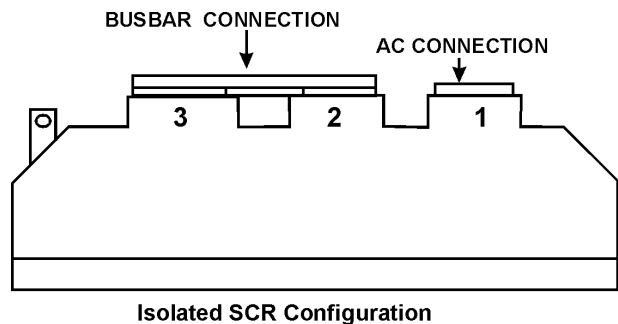

### 8.3.2 Changing a Hockey Puck Type SCR

- Remove both line and control power from unit, tag and lock out.



#### Warning!

***Failure to remove both line and control power before starting this procedure may cause personal injury or death.***

- Motortronics uses two types of clamps with gauges for reading the amount of force on the device. The first type of force gauge uses a spin washer. When the proper force is applied, the washer will be free to spin. The second type of gauge uses a step indicator on the end of the lever. Before proceeding, note the type of clamp used and, if the clamp has a step indicator, document the position of the indicator before removing the clamp to facilitate proper mounting of the new SCR device.
- Label the location of the wires connected to the SCR.
- Remove any lugs, snubbers, printed circuit boards (refer to section X) and associated wiring that may get in the way of reaching the faulty SCR. Document the location and wiring of all parts before removing them to facilitate the reinstallation of the devices later.
- Document the position of the indicator on the SCR clamp. Then remove the top clamp holding the SCR stack together. Remove the top heatsink. Use extreme caution when handling the heat sink so it does not become dented or damaged.
- Remove the faulty SCR device, noting the direction in which the SCR is oriented. The new SCR puck **must be** inserted in the same direction.
- Make sure the SCR mounting surface, tools, and hands are clean and free from dirt, nicks, and scratches. Do not sand or scrape SCR mounting surface. If necessary, super fine Scotch Brite pads can be used to clean the heatsink before installing the new SCR.
- Apply a thin (3 mil thick) layer of thermal grease uniformly along both sides of the SCR. Spread the grease to cover the entire surface of both sides of the SCR in a manner that minimizes air pockets. The grease must be free of contamination.
- Locate the centering pin in the bottom and top of the heatsink and center it in the SCR hole (making sure that the SCR is pointed in the same direction as the SCR that was removed in step 6). Locate the centering pin in the top heatsink and center it in the SCR hole.
 

**Caution: If center pin is not placed correctly it will damage the SCR and the heat sink.** Hand tighten the clamps evenly so that the same number of threads appear at both ends of the U-clamp. Tighten the clamp 1/4 turn at a time alternating sides of the U-clamp until the correct force is reached. Check the gauge or spin washer every time the clamp nuts are tightened 1/4 turn to ensure that the SCR is not over torqued. The gauge reading should be similar to the initial reading taken in step 2. If the clamp uses the spin

washer gauge, verify that the washer spins freely after clamping. Once proper force is reached make sure that the SCR pucks are securely held between the heatsinks and aligned evenly.

- Replace any lugs, MOVs, snubbers, power straps, printed circuit boards and associated wiring that was removed in step 4. Use the following chart to verify wiring of J5, J6 and J7:

Main Circuit Board Pin #	Destination
Pin 1	Load Gate
Pin 2	Load cathode (Output Load Lug)
Pin 5	Line Gate
Pin 6	Line Cathode

- After verifying that all wiring is correctly connected, test the SCR and then test the unit.

#### 8.4 Replacing the Main Control Board

The printed circuit board is not intended to be field repaired. If the board is faulty, the entire board should be replaced using the following procedure:

*(See Chapter 9 for the main control board layout.)*

- Remove three phase power and control power from the unit and lock out.
- Remove plugs and tag plugs with connector numbers.
- Remove control wires from terminals and tag wires with terminal numbers.
- Note the settings of all dip switches.
- Remove the mounting screws.
- Remove the old printed circuit board.
- Mount the new printed circuit board.
- Install the mounting screws.
- Set the dip switches to the same position as on the old board.
- Install the control wires onto correct terminals per tag sequence.
- Install the plugs.
- Apply power to the unit and test.



## **Warranty Policy**

MOTORTRONICS warrants its products to be free from defects in material and/or workmanship for a period of one year from the date of installation, to a maximum of 18 months from the date of shipment as indicated by the unit's date code. The Company reserves the right to repair or replace any malfunctioning units under warranty at their option. All warranty repairs must be performed by the Company factory, or on site by factory authorized service firms or personnel approved by the Company.

Solid state controls have different operating characteristics from those of electromechanical equipment. Because of these differences and the wide variety of applications for solid state controls, each application designer must verify that the solid state equipment is acceptable for his application. In no event will MOTORTRONICS be liable or responsible for indirect or consequential damages resulting from the use or application of this equipment. The diagrams and illustrations in this document are included solely for illustrative purposes. Because of the number of different applications, MOTORTRONICS can not be responsible or liable for actual use based on the examples or diagrams.