



**INDUSTRIAL ROTARY SCREW
AIR COMPRESSOR**

TS-32

**200-350HP/
149-261KW**

**AIR-COOLED & WATER-COOLED
STANDARD AND 24KT**

**OPERATOR'S
MANUAL AND
PARTS LIST**

**KEEP FOR
FUTURE
REFERENCE**

Part Number 02250131-544
©Sullair Corporation

AIR CARE SEMINAR TRAINING

Sullair Air Care Seminars are 3-day courses that provide hands-on instruction in the proper operation, maintenance and service of Sullair equipment. Individual seminars on Industrial compressors and compressor electrical systems are presented at regular intervals throughout the year at a dedicated training facility at Sullair's corporate headquarters in Michigan City, Indiana.

Instruction includes discussion of the function and installation of Sullair service parts, troubleshooting of the most common problems, and actual equipment operation. The seminars are recommended for maintenance and service personnel.

For detailed course outlines, schedule and cost information contact:

**Sullair Corporate Training Department
1-800-SULLAIR or 219-879-5451 (ext. 5630)**

- Or Write -

**Sullair Corporation
3700 E. Michigan Blvd.
Michigan City, IN 46360
Attn: Service Training Department**

TABLE OF CONTENTS

**OPERATOR IS REQUIRED TO READ
ENTIRE INSTRUCTION MANUAL**



Section 1 SAFETY

Page

1	1.1 GENERAL
1	1.2 PERSONAL PROTECTIVE EQUIPMENT
1	1.3 PRESSURE RELEASE
2	1.4 FIRE AND EXPLOSION
2	1.5 MOVING PARTS
2	1.6 HOT SURFACES, SHARP EDGES AND SHARP CORNERS
3	1.7 TOXIC AND IRRITATING SUBSTANCES
3	1.8 ELECTRICAL SHOCK
3	1.9 LIFTING
4	1.10 ENTRAPMENT

Section 2 DESCRIPTION

5	2.1 INTRODUCTION
5	2.2 DESCRIPTION OF COMPONENTS
5	2.3 SULLAIR COMPRESSOR UNIT, FUNCTIONAL DESCRIPTION
6	2.4 COMPRESSOR COOLING AND LUBRICATION SYSTEM, FUNCTIONAL DESCRIPTION
8	2.5 COMPRESSOR DISCHARGE SYSTEM, FUNCTIONAL DESCRIPTION
11	2.6 CONTROL SYSTEM, FUNCTIONAL DESCRIPTION
16	2.7 AIR INLET SYSTEM, FUNCTIONAL DESCRIPTION

Section 3 SPECIFICATIONS

17	3.1 SULLAIR SERIES TS-32 SPECIFICATIONS
17	3.2 LUBRICATION GUIDE- STANDARD COMPRESSORS
17	3.3 LUBRICATION GUIDE- 24KT COMPRESSORS
17	3.4 APPLICATION GUIDE
17	3.5 LUBRICATION CHANGE RECOMMENDATIONS AND MAINTENANCE
18	Figure 3-2A Identification- TS-32 Air-cooled 200-250HP/ 149-261KW
19	Figure 3-2B Identification- TS-32 Water-cooled 200-250HP/ 149-261KW

TABLE OF CONTENTS

Section 3	Page	
SPECIFICATIONS	20	Figure 3-2C Identification- TS-32 Air-cooled 300-350HP/ 224-261KW
(CONTINUED)	21	Figure 3-2D Identification- TS-32 Water-cooled 300-350HP/ 224-261KW
	22	Figure 3-3 Piping and Instrumentation
Section 4		
INSTALLATION	27	4.1 MOUNTING OF COMPRESSOR
	27	4.2 VENTILATION AND COOLING
	27	4.3 SERVICE AIR PIPING
	27	4.4 COUPLING ALIGNMENT CHECK
	27	4.5 FLUID LEVEL CHECK
	28	4.6 FLUID PIPING (REMOTE AIR-COOLED OPTION ONLY)
	29	4.7 ELECTRICAL PREPARATION
	29	4.8 MOTOR ROTATION DIRECTION CHECK
Section 5		
SUPERVISOR	31	5.1 SUPERVISOR KEYBOARD LAYOUT
	31	5.2 MAIN DISPLAY
	31	5.3 FUNCTION MENU
	32	5.4 STATUS- CURRENT PRESSURES, TEMPERATURES, INPUTS AND OUTPUTS
	32	5.5 CONTROL PARAMETERS- PRESSURE, TEMPERATURE, AND TIMER SETTINGS
	33	5.6 MAINTENANCE- PREVENTIVE MAINTENANCE INFORMATION AND TIMERS
	33	5.7 SEQUENCING- SEQUENCING & COMMUNICATION PARAMETERS
	34	5.8 SYSTEM DISPLAY- DISPLAY OF MODES OF MACHINES IN A SEQUENCING SYSTEM
	34	5.9 CALIBRATION- CORRECTION FACTORS FOR PRESSURES
	34	5.10 FACTORY SETUP- Model settings.
	35	5.11 TEST
	35	5.12 TROUBLESHOOTING INTRODUCTION
	35	5.13 TROUBLESHOOTING GUIDE- SUPERVISOR CONTROLLER
	38	Table 5-1 Alarms
Section 6		
COMPRESSOR OPERATION	39	6.1 INTRODUCTION

TABLE OF CONTENTS

Section 6 COMPRESSOR OPERATION

(CONTINUED)

Page

39	6.2 PURPOSE OF CONTROLS
40	6.3 INITIAL START-UP PROCEDURE
41	6.4 SUBSEQUENT START-UP PROCEDURE
41	6.5 SHUTDOWN PROCEDURE

Section 7 MAINTENANCE

43	7.1 GENERAL
43	7.2 DAILY OPERATION
43	7.3 MAINTENANCE AFTER INITIAL 50 HOURS OF OPERATION
43	7.4 MAINTENANCE AFTER 1000 HOURS
43	7.5 FLUID CHANGE
43	7.6 SEPARATOR MAINTENANCE
43	7.7 PARTS REPLACEMENT AND ADJUSTMENT PROCEDURES
43	MAIN FILTER MAINTENANCE
44	AIR FILTER MAINTENANCE
45	SEPARATOR ELEMENTS REPLACEMENT
46	OIL RETURN/SIGHT GLASS MAINTENANCE
46	DIFFERENTIAL PRESSURE REGULATOR ADJUSTMENT
46	DRIVE COUPLING INSTALLATION AND ALIGNMENT (200-350HP/ 149-261KW)
49	7.8 TROUBLESHOOTING
49	7.9 TROUBLESHOOTING GUIDE

Section 8 ILLUSTRATION AND PARTS LIST

53	8.1 PROCEDURE FOR ORDERING PARTS
53	8.2 RECOMMENDED SPARE PARTS LIST- 200 and 250HP/ 149 and 186KW
55	8.3 RECOMMENDED SPARE PARTS LIST- 300 and 350HP/ 224 and 261KW
56	8.4 MOTOR, COMPRESSOR, FRAME AND PARTS- GEAR DRIVE
58	8.5 MOTOR, COMPRESSOR, FRAME AND PARTS- DIRECT DRIVE
60	8.6 AIR INLET SYSTEM
64	8.7 FLUID COOLING SYSTEM- AIR-COOLED 200-250HP/ 149-186KW
68	8.8 FLUID COOLING SYSTEM- AIR-COOLED 300-350HP/ 224-261KW

TABLE OF CONTENTS

Section 8	Page	
ILLUSTRATION AND PARTS LIST		
(CONTINUED)		
	72	8.9 WATER COOLER PIPING- 200-250HP/ 149-261KW
	74	8.10 AIR PIPING SYSTEM- AIR-COOLED 200-350HP/ 149-261KW
	78	8.11 AIR PIPING SYSTEM- WATER-COOLED 200-350HP/ 149-261KW
	80	8.12 AIR PIPING SYSTEM- REMOTE COOLER 300-350HP/ 224-261KW
	82	8.13 FLUID PIPING SYSTEM- AIR-COOLED & WATER-COOLED 200-250HP/ 149-186KW
	84	8.14 FLUID PIPING SYSTEM- AIR-COOLED & WATER-COOLED 300-350HP/ 224-261KW
	86	8.15 FLUID PIPING SYSTEM- REMOTE COOLER 300-350HP/ 224-261KW
	90	8.16 SUMP AND PARTS- 200-250HP/ 149-186KW
	92	8.17 SUMP AND PARTS- 300-350HP/ 224-261KW
	94	8.18 SULLICON CONTROL
	96	8.19 COMPRESSOR ACTUATOR
	98	8.20 MOISTURE DRAIN SEPARATOR
	100	8.21 PNEUMATIC CONTROLS
	106	8.22 CONTROL BOX- SOLID STATE
	108	8.23 CONTROL BOX- FULL VOLTAGE
	110	8.24 CONTROL BOX- WYE-DELTA
	112	8.25 ENCLOSURE- AIR-COOLED 200-250HP/ 149-186KW
	116	8.26 ENCLOSURE- AIR-COOLED 300-350HP/ 224-261KW
	120	8.27 ENCLOSURE- WATER-COOLED 200-350HP/ 149-261KW
	124	8.28 DECALS
	130	8.29 DECAL LOCATIONS
	132	8.30 DECAL LOCATIONS- ENCLOSURE
	134	8.31 DECAL LOCATIONS- CONTROL BOX
	136	8.32 WIRING DIAGRAM- AIR-COOLED/FULL VOLTAGE
	137	8.33 WIRING DIAGRAM- WATER-COOLED/FULL VOLTAGE
	138	8.34 WIRING DIAGRAM- AIR-COOLED/WYE-DELTA
	139	8.35 WIRING DIAGRAM- WATER-COOLED/WYE-DELTA
	140	8.36 WIRING DIAGRAM- AIR-COOLED/SOLID STATE
	141	8.37 WIRING DIAGRAM- WATER-COOLED/SOLID STATE
	142	8.38 WIRING DIAGRAM- AIR-COOLED/REMOTE COOLER

Section 1 SAFETY

1.1 GENERAL

Sullair Corporation and its subsidiaries design and manufacture all of their products so they can be operated safely. However, the responsibility for safe operation rests with those who use and maintain these products. The following safety precautions are offered as a guide which, if conscientiously followed, will minimize the possibility of accidents throughout the useful life of this equipment.

The compressor should be operated only by those who have been trained and delegated to do so, and who have read and understood this Operator's Manual. Failure to follow the instructions, procedures and safety precautions in this manual can result in accidents and injuries. Read this manual prior to startup.

NEVER start the compressor unless it is safe to do so. **DO NOT** attempt to operate the compressor with a known unsafe condition. Tag the compressor and render it inoperative by disconnecting and locking out all power at source or otherwise disabling its prime mover, so others who may not know of the unsafe condition, cannot attempt to operate it until the condition is corrected.

Install, use and operate the compressor only in full compliance with all pertinent regulations and all applicable Federal, State, and Local codes, standards and regulations.

DO NOT modify the compressor and/or controls in any way except with written factory approval.

While not specifically applicable to all types of compressors with all types of prime movers, most of the precautionary statements contained herein are applicable to most compressors and the concepts behind these statements are generally applicable to all compressors.

1.2 PERSONAL PROTECTIVE EQUIPMENT

Prior to installing or operating the compressor, owners, employers and users should become familiar with, and comply with, all applicable regulations and any applicable Federal, State and Local codes, standards, and regulations relative to personal protective equipment, such as eye and face protective equipment, respiratory protective equipment, equipment intended to protect the extremities, protective clothing, protective shields and barriers and electrical protective equipment, as well as noise exposure administrative and/or engineering controls and/or personal hearing protective equipment.

1.3 PRESSURE RELEASE

A. Install an appropriate flow-limiting valve between

the service air outlet and the shut-off (throttle) valve, either at the compressor or at any other point along the air line, when an air hose exceeding 1/2" (13mm) inside diameter is to be connected to the shut-off (throttle) valve, to reduce pressure in case of hose failure, per all applicable Federal, State and Local codes, standards and regulations.

B. When the hose is to be used to supply a manifold, install an additional appropriate flow-limiting valve between the manifold and each air hose exceeding 1/2" (13mm) inside diameter that is to be connected to the manifold to reduce pressure in case of hose failure.

C. Provide an appropriate flow-limiting valve at the beginning of each additional 75 feet (23m) of hose in runs of air hose exceeding 1/2" (13mm) inside diameter to reduce pressure in case of hose failure.

D. Flow-limiting valves are listed by pipe size and rated CFM. Select appropriate valves accordingly, in accordance with their manufacturer's recommendations.

E. DO NOT use air tools that are rated below the maximum rating of the compressor. Select air tools, air hoses, pipes, valves, filters, and other fittings accordingly. **DO NOT** exceed manufacturer's rated safe operating pressures for these items.

F. Secure all hose connections by wire, chain or other suitable retaining devices to prevent tools or hose ends from being accidentally disconnected and expelled.

G. Open fluid filler cap only when compressor is not running and is not pressurized. Shut down the compressor and bleed the sump (receiver) to zero internal pressure before removing the cap.

H. Vent all internal pressure prior to opening any line, fitting, hose, valve, drain plug, connection or other component, such as filters and line oilers, and before attempting to refill optional air line anti-icer systems with antifreeze compound.

I. Keep personnel out of line with and away from the discharge opening of hoses or tools or other points of compressed air discharge.

J. Use air at pressures less than 30 psig (2.1 bar) for cleaning purposes, and then only with effective chip guarding and personal protective equipment.

K. DO NOT engage in horseplay with air hoses as death or serious injury may result.

L. DO NOT tamper with sump and unit (if provided) relief valves. Check the relief valve as recommended in the Maintenance Section of this manual

Section 1 SAFETY

or at a minimum of at least weekly to make sure it is not blocked, clogged, obstructed or otherwise disabled. **DO NOT** change the factory setting of the relief valve.

M. If the compressor is installed in an enclosed area, it is necessary to vent the relief valve to the outside of the structure or to an area of non-exposure.

1.4 FIRE AND EXPLOSION



When installing a Base Load Transfer (BLT) System, remove jumpers between 16-17 & 18-19 (Dual Control Compressors) so the other compressor does not backfeed defeating the shut-down circuitry.

A. Clean up spills of lubricant or other combustible substances immediately, if such spills occur.

B. Shut off the compressor and allow it to cool. Then keep sparks, flames and other sources of ignition away and **DO NOT** permit smoking in the vicinity when checking or adding lubricant or when refilling air line anti-icer systems with antifreeze compound.

C. DO NOT permit fluids, including air line anti-icer system antifreeze compound or fluid film to accumulate on, under, or around acoustical material, or on any external surfaces of the air compressor or on internal surfaces of the enclosure. Wipe down using an aqueous industrial cleaner or steam-clean as required. If necessary, remove acoustical material, clean all surfaces and then replace acoustical material. Any acoustical material with a protective covering that has been torn or punctured should be replaced immediately to prevent accumulation of liquids or fluid film within the material. **DO NOT** use flammable solvents for cleaning purposes.

D. Disconnect and lock out all power at source prior to attempting any repairs or cleaning of the compressor or of the inside of the enclosure, if any.

E. Keep electrical wiring, including all terminals and pressure connectors in good condition. Replace any wiring that has cracked, cut abraded or otherwise degraded insulation, or terminals that are worn, discolored or corroded. Keep all terminals and pressure connectors clean and tight.

F. Keep grounded and/or conductive objects such as tools away from exposed live electrical parts such as terminals to avoid arcing which might serve as a source of ignition.

G. Remove any acoustical material or other materi-

al that may be damaged by heat or that may support combustion and is in close proximity, prior to attempting weld repairs.

H. Keep suitable fully charged fire extinguisher or extinguishers nearby when servicing and operating the compressor.

I. Keep oily rags, trash, leaves, litter or other combustibles out of and away from the compressor.

J. DO NOT operate the compressor without proper flow of cooling air or water or with inadequate flow of lubricant or with degraded lubricant.

K. DO NOT attempt to operate the compressor in any classification of hazardous environment unless the compressor has been specially designed and manufactured for that duty.

1.5 MOVING PARTS

A. Keep hands, arms and other parts of the body and also clothing away from couplings, fans and other moving parts.

B. DO NOT attempt to operate the compressor with the fan, coupling or other guards removed.

C. Wear snug-fitting clothing and confine long hair when working around this compressor, especially when exposed to hot or moving parts.

D. Keep access doors, if any, closed except when making repairs or adjustments.

E. Make sure all personnel are out of and/or clear of the compressor prior to attempting to start or operate it.

F. Disconnect and lock out all power at source and verify at the compressor that all circuits are de-energized to minimize the possibility of accidental start-up or operation, prior to attempting repairs or adjustments. This is especially important when compressors are remotely controlled.

G. Keep hands, feet, floors, controls and walking surfaces clean and free of fluid, water, or other liquids to minimize the possibility of slips and falls.

1.6 HOT SURFACES, SHARP EDGES AND SHARP CORNERS

A. Avoid bodily contact with hot fluid, hot coolant, hot surfaces and sharp edges and corners.

B. Keep all parts of the body away from all points of air discharge.

C. Wear personal protective equipment including gloves and head covering when working in, on or around the compressor.

D. Keep a first aid kit handy. Seek medical assistance promptly in case of injury. **DO NOT** ignore

small cuts and burns as they may lead to infection.

1.7 TOXIC AND IRRITATING SUBSTANCES

A. DO NOT use air from this compressor for respiration (breathing) except in full compliance with any Federal, State or Local Codes or regulations.



Death or serious injury can result from inhaling compressed air without using proper safety equipment.

B. DO NOT use air line anti-icer systems in air lines supplying respirators or other breathing air utilization equipment and **DO NOT** discharge air from these systems in unventilated or other confined areas.

C. Operate the compressor only in open or adequately ventilated areas.

D. Locate the compressor or provide a remote inlet so that it is not likely to ingest exhaust fumes or other toxic, noxious or corrosive fumes or substances.

E. Coolants and lubricants used in this compressor are typical of the industry. Care should be taken to avoid accidental ingestion and/or skin contact. In the event of ingestion, seek medical treatment promptly. Wash with soap and water in the event of skin contact. Consult the compressor operator's manual lubrication section for information pertaining to compressor fluid fill.

F. Wear goggles or a full face shield when adding antifreeze compound to air line anti-icer systems.

G. If air line anti-icer system antifreeze compound enters the eyes or if fumes irritate the eyes, they should be washed with large quantities of clean water for 15 minutes. A physician, preferably an eye specialist, should be contacted immediately.

H. DO NOT store air line anti-icer system antifreeze compound in confined areas.

I. The antifreeze compound used in air line antifreeze systems contains methanol and is toxic, harmful, or fatal if swallowed. Avoid contact with the skin or eyes and avoid breathing the fumes. If swallowed, induce vomiting by administering a tablespoon of salt, in each glass of clean, warm water until vomit is clear, then administer two teaspoons of baking soda in a glass of clean water. Have patient lay down and cover eyes to exclude light. Call a physician immediately.

1.8 ELECTRICAL SHOCK

A. This compressor should be installed and main-

tained in full compliance with all applicable Federal, State and Local codes, standards and regulations, including those of the National Electrical Code, and also including those relative to equipment grounding conductors, and only by personnel that are trained, qualified and delegated to do so.

B. Keep all parts of the body and any hand-held tools or other conductive objects away from exposed live parts of electrical system. Maintain dry footing, stand on insulating surfaces and **DO NOT** contact any other portion of the compressor when making adjustments or repairs to exposed live parts of the electrical system. Make all such adjustments or repairs with one hand only, so as to minimize the possibility of creating a current path through the heart.

C. Attempt repairs in clean, dry and well lighted and ventilated areas only.

D. DO NOT leave the compressor unattended with open electrical enclosures. If necessary to do so, then disconnect, lock out and tag all power at source so others will not inadvertently restore power.

E. Disconnect, lock out, and tag all power at source prior to attempting repairs or adjustments to rotating machinery and prior to handling any ungrounded conductors.

F. Dry test all shutdown circuits prior to starting the compressor after installation.

1.9 LIFTING

A. If the compressor is provided with a lifting bail, then lift by the bail provided. If no bail is provided, then lift by sling. Compressors to be air lifted by helicopter must not be supported by the lifting bail but by slings instead. In any event, lift and/or handle only in full compliance with Federal, State and Local codes.

B. Inspect points of attachment for cracked welds and for cracked, bent, corroded or otherwise degraded members and for loose bolts or nuts prior to lifting.

C. Make sure entire lifting, rigging and supporting structure has been inspected, is in good condition and has a rated capacity of at least the weight of the compressor. If you are unsure of the weight, then weigh compressor before lifting.

D. Make sure lifting hook has a functional safety latch or equivalent, and is fully engaged and latched on the bail or slings.

E. Use guide ropes or equivalent to prevent twisting

Section 1

SAFETY

or swinging of the compressor once it has been lifted clear of the ground.

F. DO NOT attempt to lift in high winds.

G. Keep all personnel out from under and away from the compressor whenever it is suspended.

H. Lift compressor no higher than necessary.

I. Keep lift operator in constant attendance whenever compressor is suspended.

J. Set compressor down only on a level surface capable of safely supporting at least its weight and its loading unit.

K. When moving compressors by forklift truck, utilize fork pockets if provided. Otherwise, utilize pallet if provided. If neither fork pockets or pallet are provided, then make sure compressor is secure and well balanced on forks before attempting to raise or transport it any significant distance.

L. Make sure forklift truck forks are fully engaged and tipped back prior to lifting or transporting the compressor.

M. Forklift no higher than necessary to clear obstacles at floor level and transport and corner at mini-

mum practical speeds.

N. Make sure pallet-mounted compressors are firmly bolted or otherwise secured to the pallet prior to attempting to forklift or transport them. **NEVER** attempt to forklift a compressor that is not secured to its pallet, as uneven floors or sudden stops may cause the compressor to tumble off, possibly causing serious injury or property damage in the process.

O. DO NOT use the lifting eye bolt on the compressor motor, if supplied, to lift the entire compressor package.

1.10 ENTRAPMENT

A. If the compressor enclosure is large enough to hold a person and if it is necessary to enter it to perform service adjustments, inform other personnel before doing so, or else secure and tag the access door in the open position to avoid the possibility of others closing and possibly latching the door with personnel inside.

B. Make sure all personnel are out of compressor before closing and latching enclosure doors.

Section 2 DESCRIPTION

2.1 INTRODUCTION

Refer to Figures 2-1A and 2-1B. Your new Sullair lubricated rotary screw air compressor provides you with a unique experience in improved reliability and greatly reduced maintenance.

Compared to other types of compressors, the Sullair rotary screw is unique in its mechanical reliability and lack of "wear". The compressor requires absolutely no inspection of its internal parts.

By reading through Section 6, you will notice the easy process of caring and maintaining this Sullair manufactured product. Should any questions arise which cannot be answered in this text, call your nearest Sullair representative or the Sullair Corporation Service Department.

2.2 DESCRIPTION OF COMPONENTS

Refer to Figures 2-1A and 2-1B. The components and assemblies of the air compressors are clearly shown. The complete package includes **compressor, electric motor, compressor inlet system, compressor discharge system, compressor cooling and lubrication system, capacity con-**

trol system and Supervisor Controller™, micro-processor system and starter all mounted on a structural steel frame

On air-cooled models, a fan draws air over the fan motor and forces it through the combined aftercooler and fluid cooler, thereby removing the heat of compression from the cooling fluid.

On water-cooled models, fluid is piped into a water-cooled heat exchanger where the heat of compression is removed from the fluid. A fan is used to supply sufficient ventilating air to compressors equipped with an optional enclosure.

Both air-cooled and water-cooled versions have easily accessible items such as the fluid filters and control valves. The inlet air filters are also mounted for easy access and servicing.

2.3 SULLAIR COMPRESSOR UNIT, FUNCTIONAL DESCRIPTION

Sullair tandem air compressors feature the Sullair compressor unit, a two-stage, positive displacement fluid lubricated-type compressor. This unit

Figure 2-1A Sullair Series TS-32 Rotary Screw Compressor (Air-cooled Version)

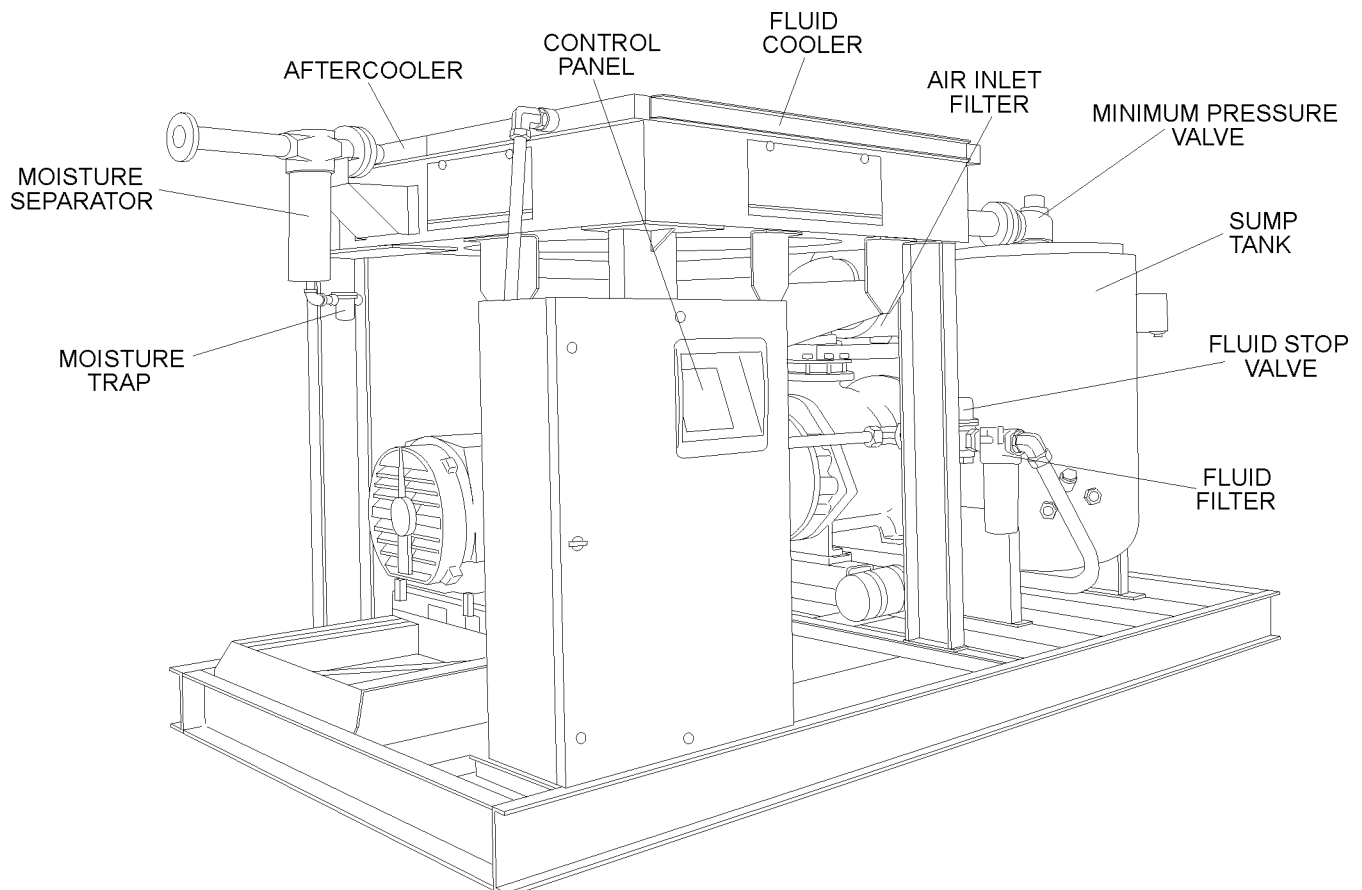

Section 2 DESCRIPTION

Figure 2-1B Sullair Series TS-32 Rotary Screw Compressor (Water-cooled Version)

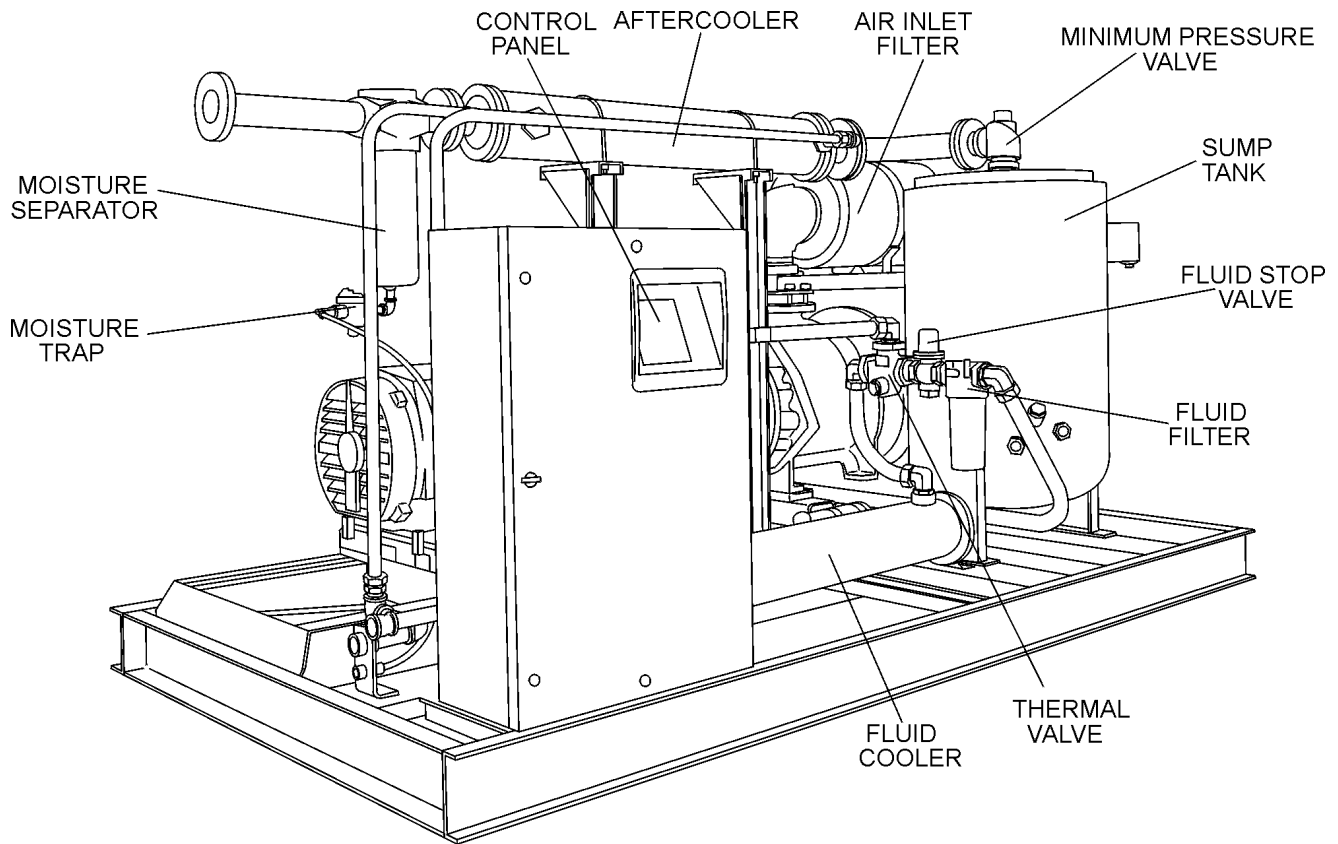

provides continuous air compression to meet your needs.

Fluid is injected into the compressor unit where it mixes directly with the air as the internal rotors turn, compressing the air. The fluid flow has three basic functions:

1. As coolant, it controls the rise of air temperature normally associated with the heat of compression.
2. Seals the leakage paths between the rotors and the stator and also between the rotors themselves.
3. Acts as a lubricating film between the rotors allowing one rotor to directly drive the other, which is an idler. After the air/fluid mixture is discharged from the compressor unit, the fluid is separated from the air. At this time, the air flows to the service line and the fluid is cooled in preparation for re-injection.

NOTE

With a Sullair compressor, there is no maintenance or inspection of the internal parts of the compressor unit permitted in accordance with the terms of the warranty.

2.4 COMPRESSOR COOLING AND LUBRICATION SYSTEM, FUNCTIONAL DESCRIPTION

Refer to Figures 2-2, 2-3A, 2-3B, 2-4A, 2-4B, 2-5A, 2-5B, 2-5C and 2-5D. The cooling and lubrication system consists of a **fluid cooler, full flow fluid filter, fluid stop valve, thermal valve.**

The pressure in the receiver/sump causes fluid flow by forcing the fluid from the high pressure area of the sump to an area of lower pressure in the compressor unit.

Fluid flows from the receiver/sump to the thermal valve. The thermal valve is fully open to the compressor unit when the discharge temperature is below 170°F (77°C) for all compressors, except water-cooled 24KT models, which is fully open up to 195°F (91°C). The fluid passes through the thermal valve, the fluid stop valve, the main fluid filter and directly to the compressor unit.

As the discharge temperature rises above 170°F (77°C) for all compressors (195°F [91°C] for water-cooled 24KT models), due to the heat of compression, the thermal valve begins to close and a portion of the fluid then flows through the cooler. From the

Section 2 DESCRIPTION

Figure 2-2 Compressor Piping and Instrument Diagram (200, 250, 300HP/ 150, 187, 225KW)

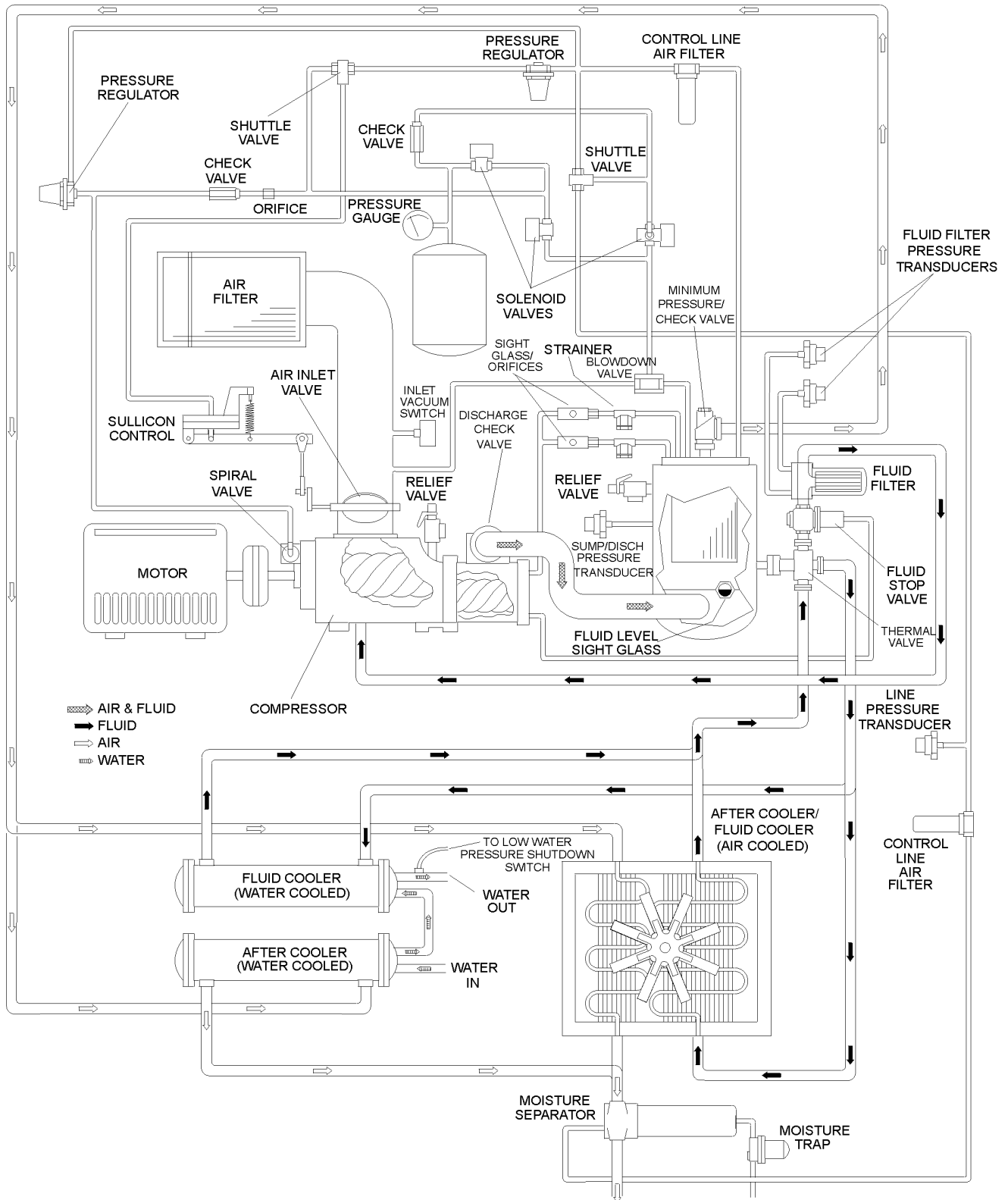

Section 2 DESCRIPTION

Figure 2-3A Compressor Cooling and Lubrication System (300-350HP/ 224-261KW Air-cooled)

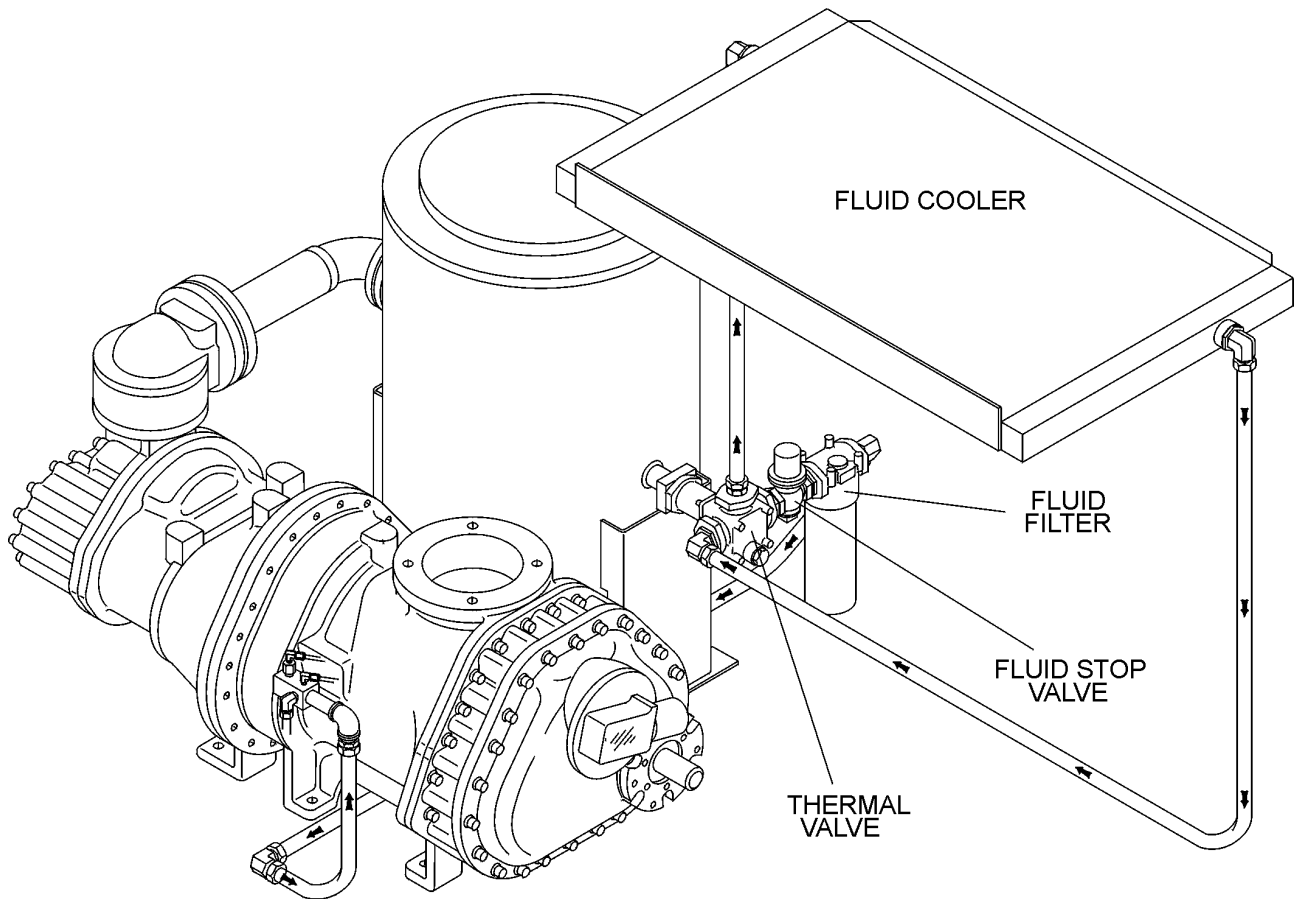

cooler, the fluid flows to the main filter, the fluid stop valve, and on to the compressor unit. The fluid filter has a replacement element and an integral pressure bypass valve.

The fluid stop valve prevents fluid from filling the compressor unit when the compressor is shut down. When the compressor is operating, the fluid stop valve is held open by air pressure from the compressor unit allowing a free flow of fluid from the receiver/sump back to the compressor unit. On shutdown, the compressor unit pressure is reduced, causing the fluid stop valve to close and isolate the compressor unit from the cooling system.

Water-cooled models have a water pressure switch to prevent operation with inadequate water pressure.

2.5 COMPRESSOR DISCHARGE SYSTEM, FUNCTIONAL DESCRIPTION

Refer to Figures 2-2, 2-4A and 2-4B. The compressor unit discharges the compressed air/fluid

mixture through a discharge check valve into the combination receiver/sump. The discharge check valve prevents air/fluid in the receiver from returning to the compression chamber after the compressor has been shut down. The receiver has three functions:

1. It acts as a primary fluid separator.
2. It serves as the compressor fluid sump.
3. It houses the final fluid/air separator elements.

The compressed air/fluid mixture enters the receiver and is directed against an internal baffle. The direction of movement is changed and its velocity significantly reduced, thus causing the large droplets of fluid to fall to the bottom of the receiver/sump. The fractional percentage of fluid remaining in the compressed air collects on the surface of the nested separator elements (primary and secondary) as the compressed air flows through them. Two return lines (or scavenge tubes) lead from the bottom of each separator element to the low pressure inlet region of the compressor unit. Fluid col-

Section 2 DESCRIPTION

lecting on the bottom of each separator is returned to the compressor by a pressure difference between the receiver and the compressor inlet. Sight glasses are located in the return lines to observe this fluid flow. dP1 on the Supervisor Controller™ microprocessor control monitors the condition of the separator elements by reading the differential pressure on the digital display. At a differential of 10 PSIG (0.7 bar), or greater, the operator will be told to service the separator elements. At this time, separator element replacement is necessary.

The receiver is an ASME pressure vessel. A combination minimum pressure/check valve, located downstream from the separator, assures a minimum receiver pressure of 50 psig (3.4 bar) during full load operation. This pressure is necessary for proper air/fluid separation and proper fluid circulation while supplying air to the system. This valve also acts as a check valve preventing compressed air in the service line from bleeding back into the receiver on shutdown and during operation of the

compressor in an unloaded condition.

A pressure relief valve (located on the wet side of the separator) is set to open if the sump pressure exceeds the rated pressure of the tank.

All Sullair compressor models are equipped with high pressure shutdown protection to shut down the compressor at 20-35psi above rated pressure. This prevents the pressure relief valve from opening under normal conditions, thereby preventing fluid loss through the pressure relief valve. A temperature switch will shut down the compressor if the discharge temperature reaches 235°F (113°C).

WARNING

DO NOT remove caps, plugs, and/or other components when compressor is running or pressurized.

Stop compressor and relieve all internal pressure before doing so.

Fluid is added to the sump via a capped fluid filler opening, placed low on the receiver tank to prevent over-filling of the sump. Two sight glasses enables

Figure 2-3B Compressor Cooling and Lubrication System (300-350HP/ 224-261KW Water-cooled)

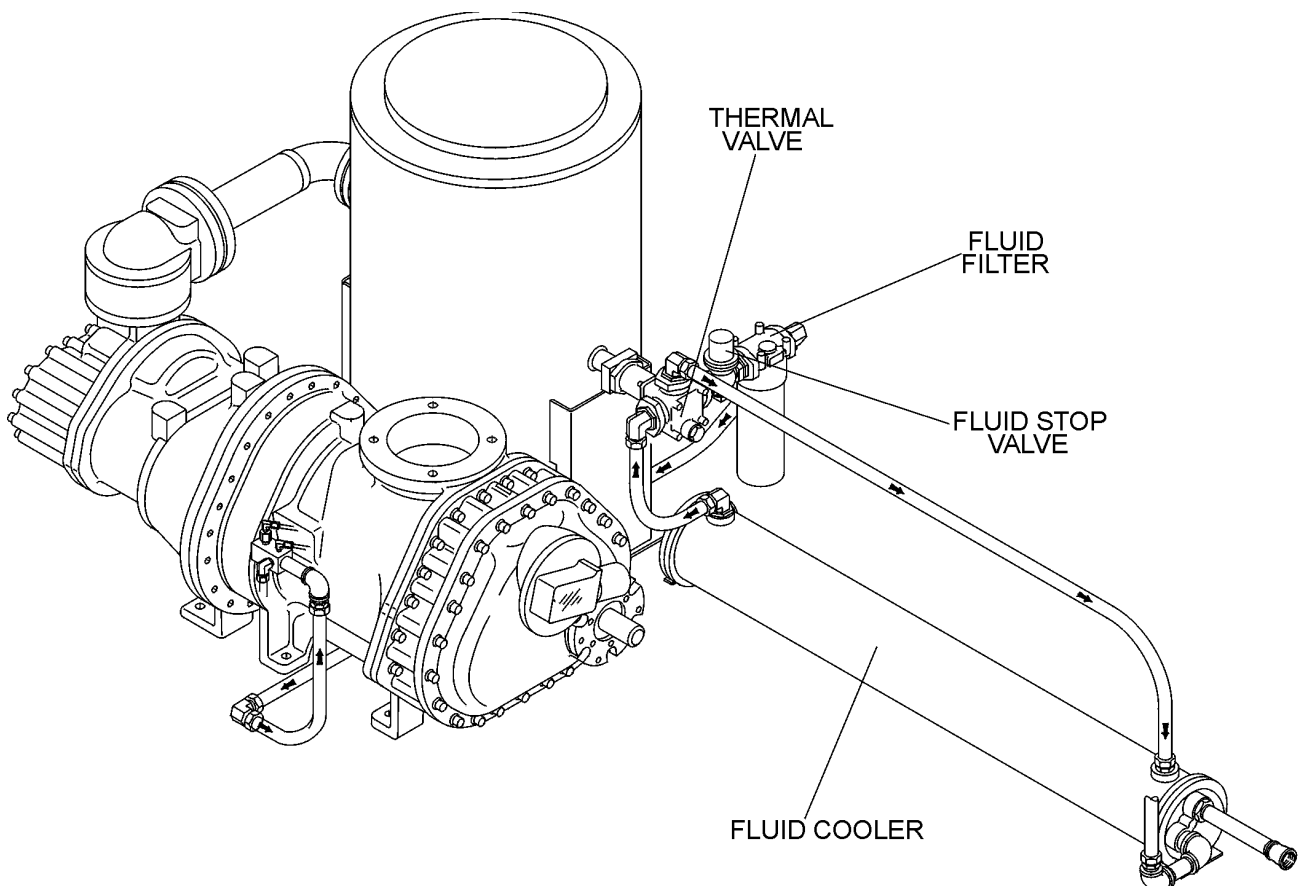

Section 2 DESCRIPTION

Figure 2-4A Compressor Discharge System (200-350HP/ 149-261KW Air-cooled)

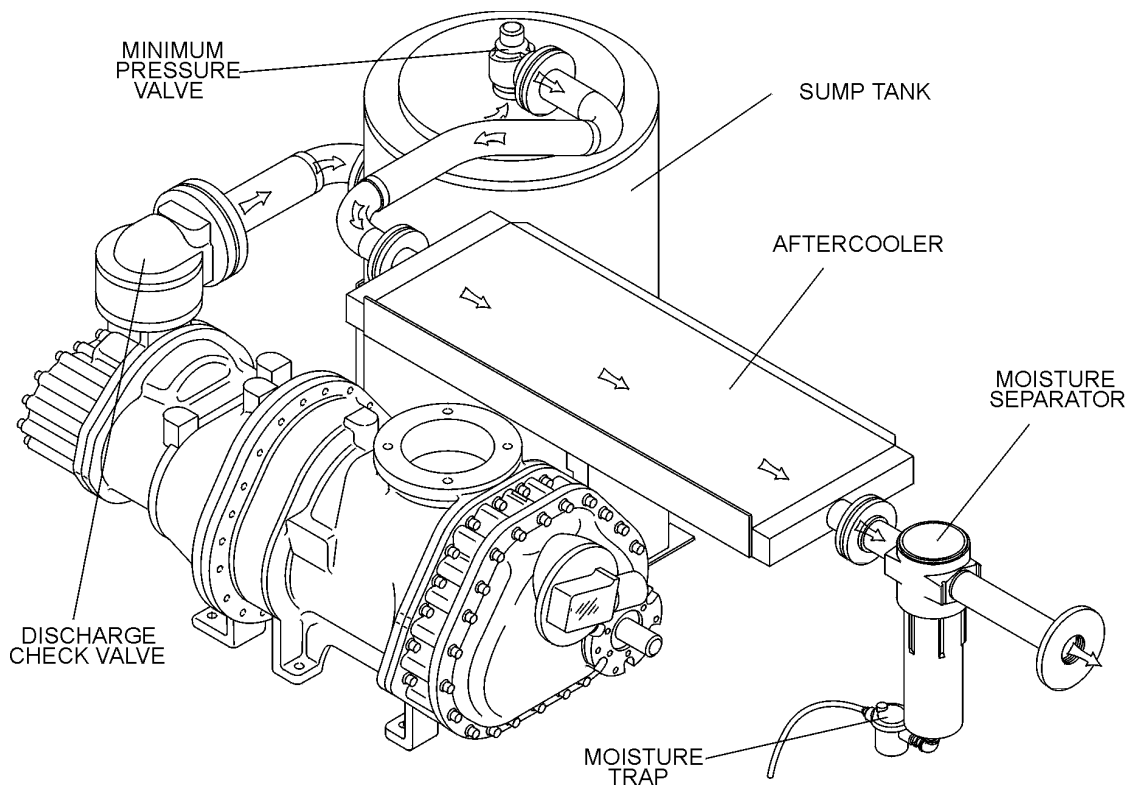
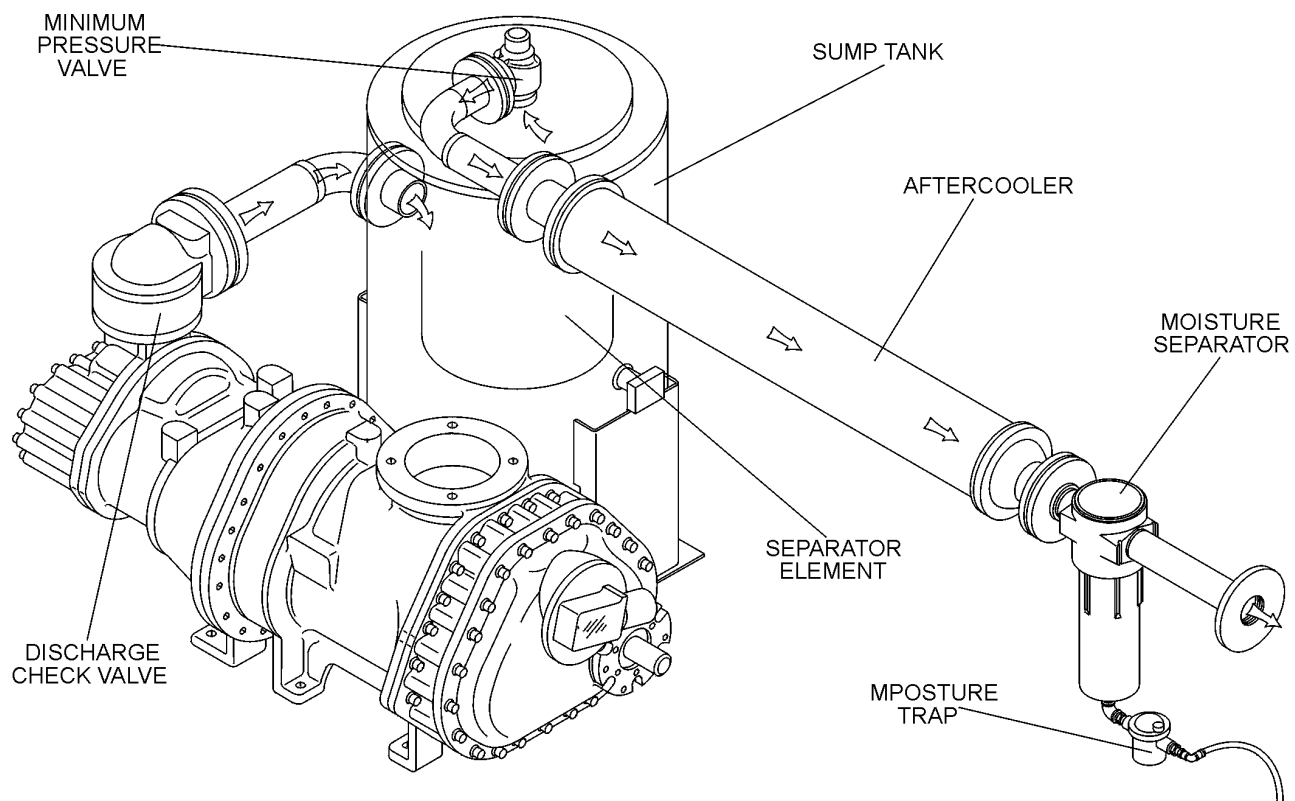

Figure 2-4B Compressor Discharge System (200-350HP/ 149-261KW Water-cooled)



Section 2 DESCRIPTION

the operator to visually monitor the sump fluid level.

2.6 CONTROL SYSTEM, FUNCTIONAL DESCRIPTION

Refer to Figures 2-5A, 2-5B, 2-5C and 2-5D. The purpose of the compressor control system is to regulate the amount of air being compressed to match the amount of compressed air being used.

The capacity control system consists of a spiral valve and an inlet butterfly valve. The functional description of the control system is described below in 4 distinct phases of compressor operation. The following applies to TS-32 Series compressors ranging from 200 through 350HP. For explanatory purposes, this description applies to any compressor with an operating range of 100 to 110 psig (6.9 to 7.6 bar). A compressor with any other pressure range would operate in the same manner except for the stated pressures.

START MODE - 0 TO 50 PSIG (0 TO 3.4 BAR)

When the compressor  (ON) pad is depressed, the sump pressure will quickly rise from 0 to 50 psig (0 to 3.4 bar). During this period, both of the pressure regulators and the solenoid valve are closed and the Sullicon Control and spiral valve are inoperative. The spring on the control holds the butterfly valve fully open while the spiral valve is fully closed (maximum) position and the compressor pumps at full rated capacity. The rising compressor air pressure is isolated from the service line in this phase by the minimum pressure valve set at approximately 50 psig (3.4 bar).

A standard closed inlet system is provided which uses air pressure to close the butterfly and opens the spiral valve to reduce motor torque for starting.

FULL LOAD MODE - 50 TO 100 PSIG (3.4 TO 6.9 BAR)

When the compressed air pressure in the sump rises above 50 psig (3.4 bar), the minimum pressure valve opens, allowing compressed air to flow into the service line. From this point on, the line air pressure is continually monitored by the Supervisor. The pressure regulators and the solenoid valve remain closed during this phase, keeping the Sullicon Control and spiral valve inactive. Both the spiral valve as well as the inlet butterfly valve remain in the full load position as long as the compressor is running at 100 psig (6.9 bar) or below.

MODULATION - 100 TO 110 PSIG (6.9 TO 7.6 BAR)

As air demand drops below the rated capacity of the compressor, the line pressure will rise above 100

psig (6.9 bar). As a result, the differential pressure regulator for the spiral valve gradually opens, applying air pressure to the spiral valve actuator. Air pressure at the actuator expands the diaphragm. The rack, in turn, engages with the pinion mounted on the spiral valve shaft assembly. This results in a rotary motion. As the spiral valve rotates, it starts opening the bypass ports gradually. Excess air is then being returned back internally to suction end of compressor unit. Now the compressor is fully compressing only that amount of air which is being used. As air demand keeps dropping further, the spiral valve keeps opening more and more until all the bypass ports are fully open. At this point, the spiral valve has moved into the minimum position.

The spiral valve provides a modulation range from 100 to approximately 50%. During this period, the pressure rises approximately from 100 to 108 psig (6.9 to 7.4 bar). As the air pressure exceeds 108 psig (7.4 bar), the differential pressure regulator controlling the Sullicon Control opens. This allows the air pressure to expand the diaphragm chamber of the Sullicon Control, which starts partially closing the inlet butterfly valve. The inlet butterfly valve provides modulation range from 50 to 40%. During this period, the pressure rises approximately from 108 to 110 psig (7.4 to 7.6 bar). During this range, the spiral valve remains in the full open position.

UNLOAD MODE - IN EXCESS OF 110 PSIG (7.6 BAR)

When a relatively small amount or no air is being used, the service line pressure continues to rise. When it exceeds 110 psig (7.6 bar), Supervisor de-energizes the solenoid valve allowing line pressure to be supplied directly to the Sullicon diaphragm keeping the inlet butterfly closed; the spiral valve is in the fully open (minimum) position. Simultaneously, the solenoid valve sends a pneumatic signal to the blowdown valve. The blowdown valve opens the sump to the atmosphere. This reduces the sump pressure to approximately 30 psig (2.1 bar) which results in low horsepower consumption. The check valve in the air service line prevents line pressure from returning to sump while the compressor is running in the unloaded mode. Both the spiral valve and the butterfly valve remain in the unload position.

When the line pressure drops back to 100 psig (6.9 bar) due to an increase in the air demand, Supervisor energizes the solenoid valve allowing the air pressure behind the Sullicon Control to be vented through the solenoid valve exhaust port. The blowdown valve closes, and the inlet butterfly

Section 2 DESCRIPTION

Figure 2-5A Control System- START (200-350HP/ 149-261KW)

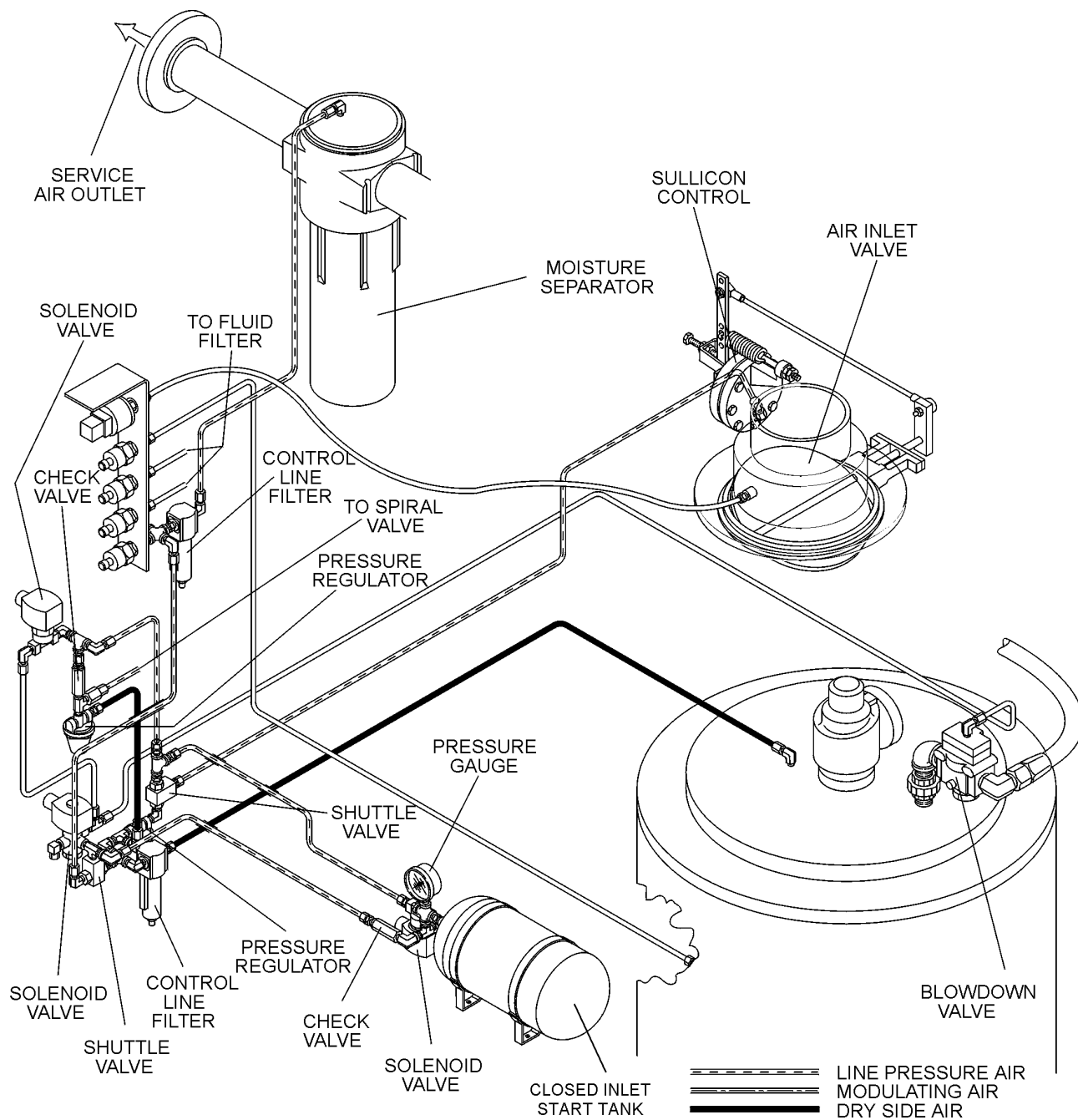

Section 2 DESCRIPTION

Figure 2-5B Control System MODULATION (200-350HP/ 149-261KW)

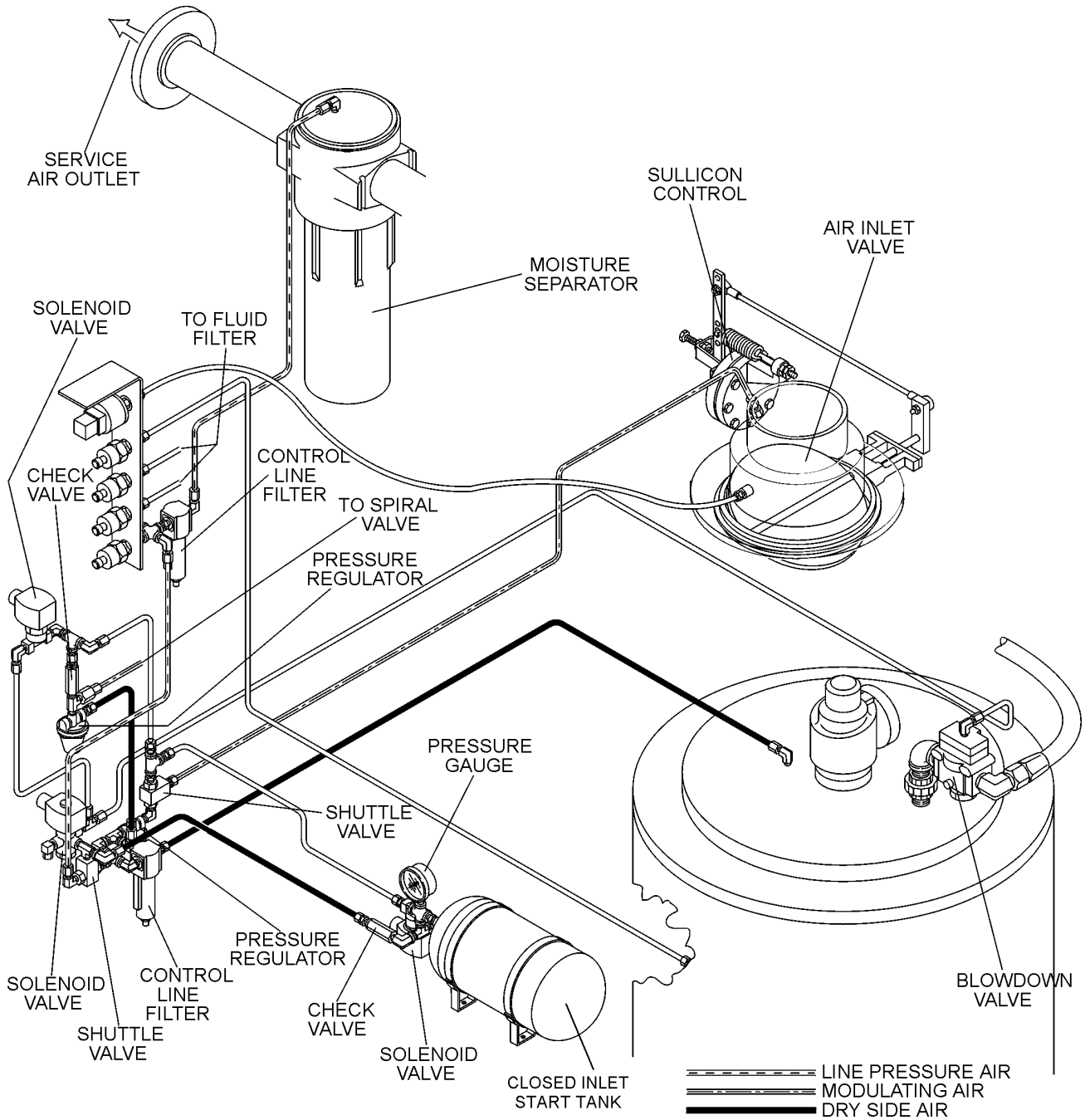

Section 2 DESCRIPTION

Figure 2-5C Control System- UNLOAD (200-350HP/ 149-261KW)

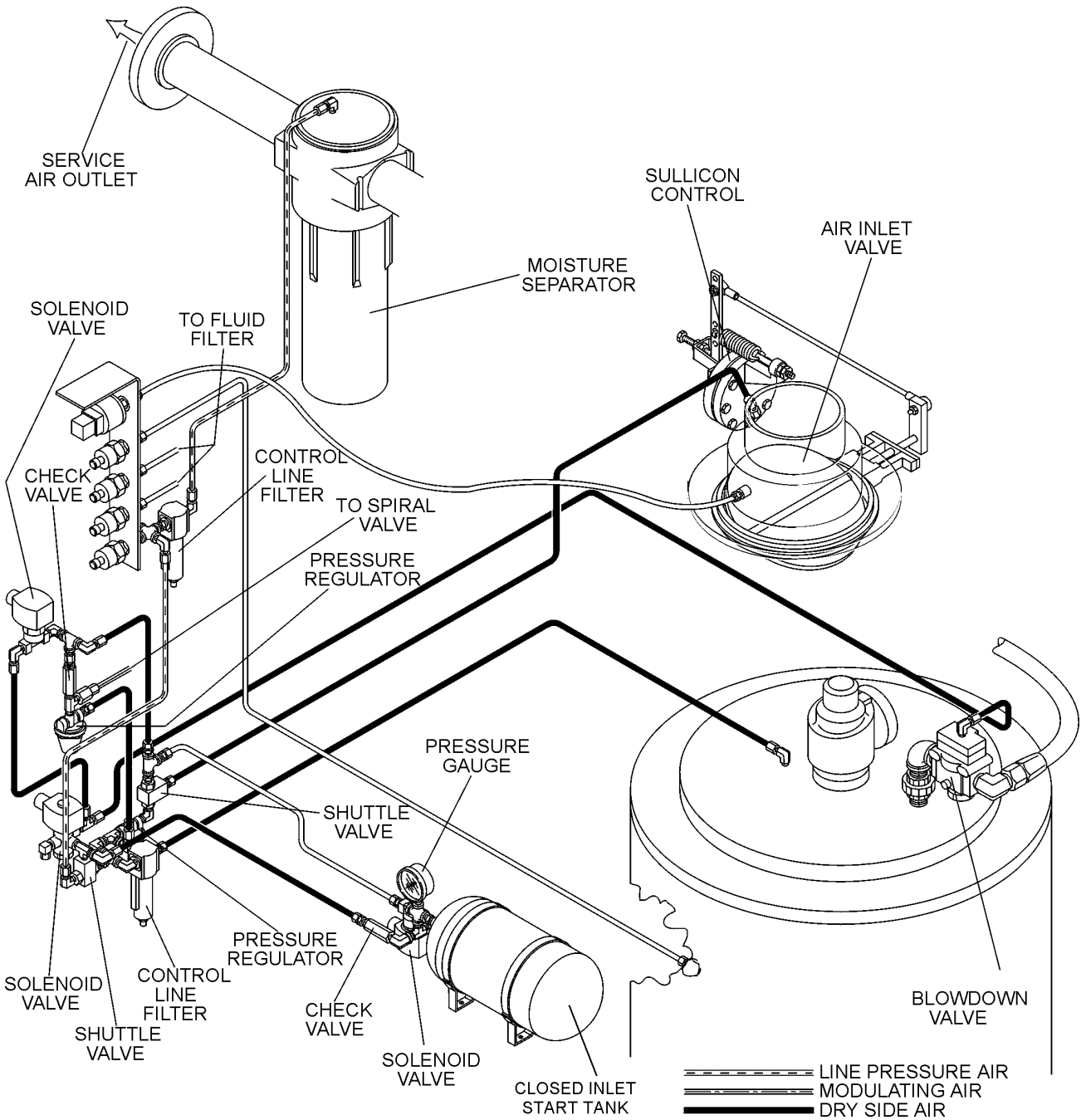

Section 2 DESCRIPTION

Figure 2-5D Control System- FULL LOAD (200-350HP/ 149-261KW)

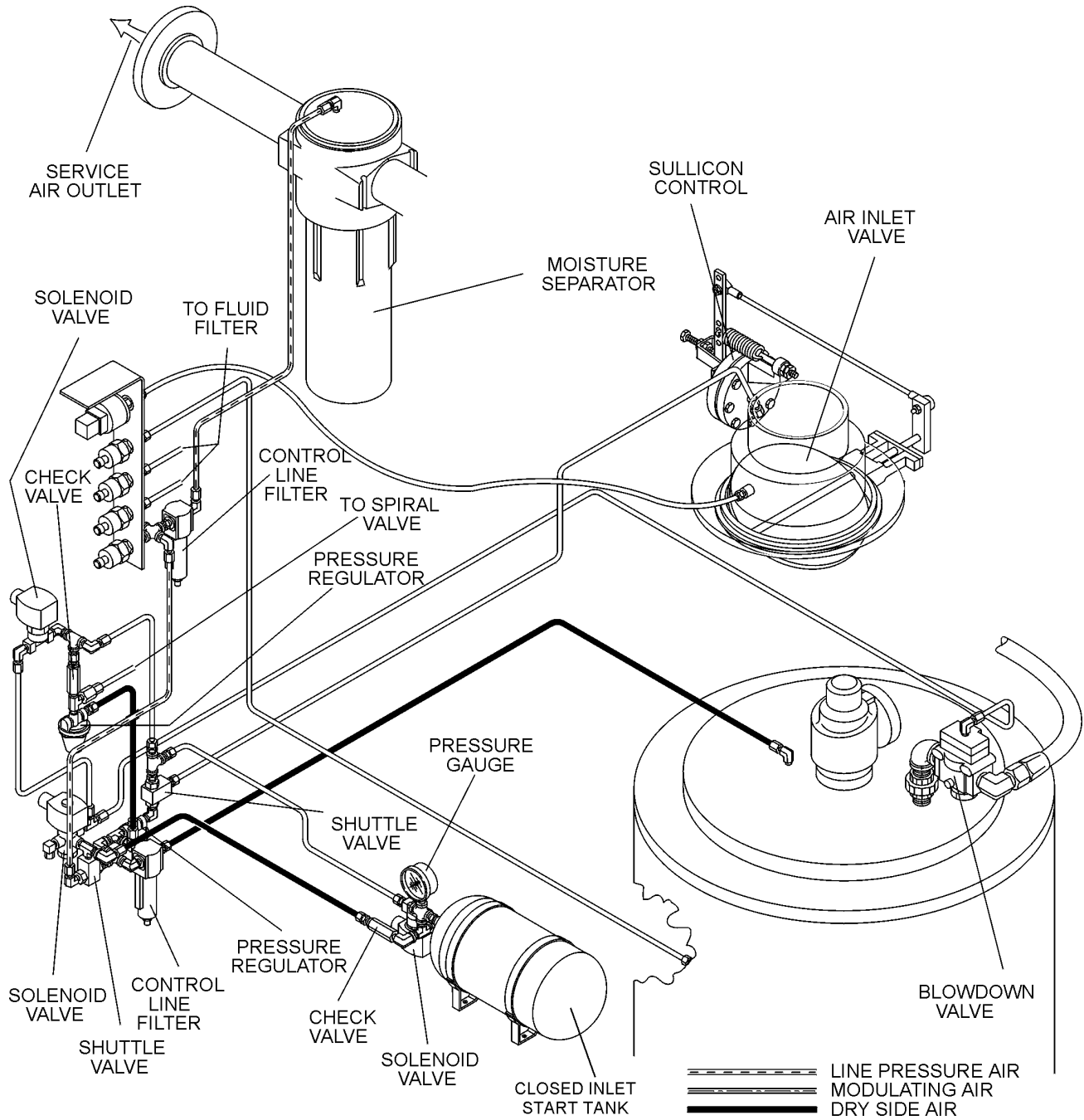

Section 2 DESCRIPTION

Figure 2-6 Compressor Air Inlet System

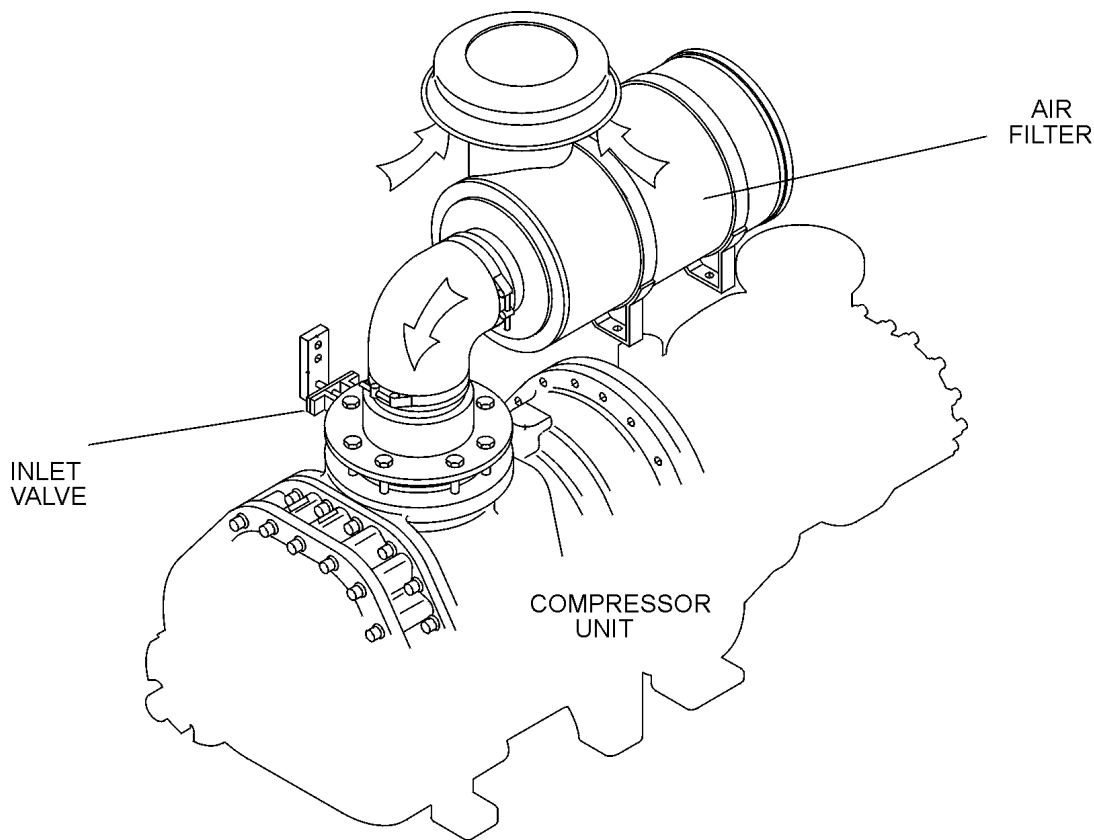

valve opens. Also the air pressure at the spiral valve actuator diaphragm is reduced through a vent hole at the spiral valve differential pressure regulator, and a spring in the actuator causes the spiral valve to return to the full load (maximum) position.

AUTOMATIC OPERATION

For applications with varied periods of time when there are no air requirements, Supervisor's Auto mode allows the compressor to shut down (time delayed) when no compressed air requirement is present and restart as compressed air is needed.

LOAD/ NO LOAD OPERATION

If applications call for load/no load operation, modulation can be disabled in the Supervisor Controller™ in the "Control Parameters" menu. If modulation is disabled, the unload pressure must be reset to the rated load pressure of the machine. For example, an L model rated for 100 psig full load

operation and 110 psig unload must have the unload pressure reset to 100 psig. This ensures that the motor will not run in an overload condition.

2.7 AIR INLET SYSTEM, FUNCTIONAL DESCRIPTION

Refer to Figure 2-6. The compressor inlet system consists of one or two dry-type air filters, a vacuum switch and an air inlet valve.

The vacuum switch, located in the compressor Supervisor control system, indicates the condition of the air filter. When the message "AIR FILTER MAINT RQD" is displayed, maintenance is required.

The butterfly-type air inlet valve directly controls the amount of air intake to the compressor in response to the operation of the Sullicon Control (Section 2.6).

Section 3 SPECIFICATIONS

3.1 SULLAIR SERIES TS-32 SPECIFICATIONS

60 HZ MODEL (AC & WC)	LENGTH (IN)	WIDTH (IN)	HEIGHT (I) (IN)	WEIGHT (LB)
	154	78	86	(II)

50Hz MODEL (AC & WC)	LENGTH (CM)	WIDTH (CM)	HEIGHT (I) (CM)	WEIGHT (KG)
	392	198	218	(II)

(I) Add 7 in./18 cm for enclosure. Add 27.5 in./70 cm (200-350HP/149-261KW) for servicing the separator.

(II) For data on package weights, consult Sullair Factory Sales Department.

NOTE

For noise level information, please contact the Sullair Factory Service Department.

3.2 LUBRICATION GUIDE-STANDARD COMPRESSORS

Refer to Figure 3-1. Sullair TS-32 Series standard compressors are filled with Sullube fluid as factory fill.

⚠ WARNING

Mixing of other lubricants within the compressor unit will void all warranties.

Sullube fluid should be changed every 8000 hours or once a year, whichever comes first. The fluid should be changed more frequently under severe operating conditions, such as high ambient temperatures coupled with high humidity, or when high particulate level, corrosive gases or strong oxidizing gases are present in the air.

Maintenance of all other components is still recommended as indicated in the Maintenance section of this manual.

3.3 LUBRICATION GUIDE- 24KT COMPRESSORS

See Figure 3-1. Sullair 24KT compressors are filled with a lubricant which rarely ever needs to be changed. In the event a change of fluid or make-up fluid is required, use only Sullair 24KT fluid.

⚠ WARNING

Mixing of other lubricants within the compressor unit will void all warranties.

Sullair recommends that 24KT sample be taken at the first filter change and sent to the factory for analysis. This is a free service. A sample kit with instructions and self addressed container is to supplied by your Sullair representative at start-up. The user will receive an analysis report with recommendations.

NOTE

A 24KT sample should be sent in annually, after the first year.

3.4 APPLICATION GUIDE

Sullair encourages the user to participate in a fluid analysis program with the fluid suppliers. This could result in a fluid change interval differing from that stated in the manual. Contact your Sullair dealer for details.

3.5 LUBRICATION CHANGE RECOMMENDATIONS AND MAINTENANCE

LUBRICANT	FLUID CHANGE	FLUID FILTER CHANGE	SEPARATOR CHANGE
Sullube 24KT	A, D E, D	F, B F, B	A, C A, C

A - 8,000 Hours or once a year

B - When measured pressure loss exceeds 20 psig (1.3 bar).

C - When measured pressure loss exceeds 10 psig (0.7 bar).

D - When required by fluid analysis or known contamination.

E - Does not require replacement during normal service conditions.

F - Every 1000 hours.

Figure 3-1 Fluid Fill Location

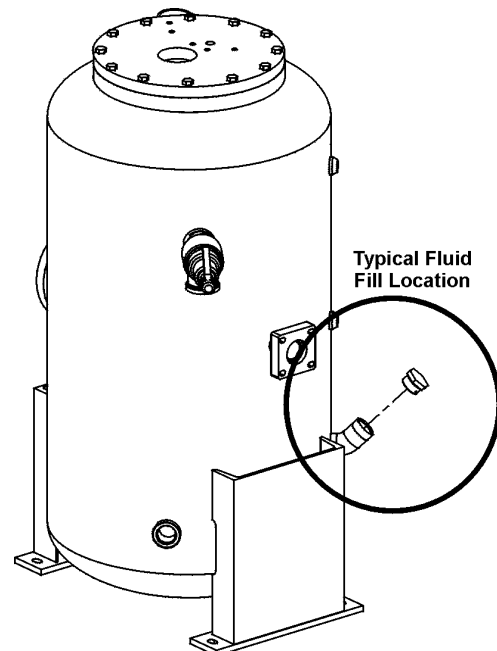

Section 3 SPECIFICATIONS

Figure 3-2A Identification- TS-32 Air-cooled 200-250HP/ 149-186KW

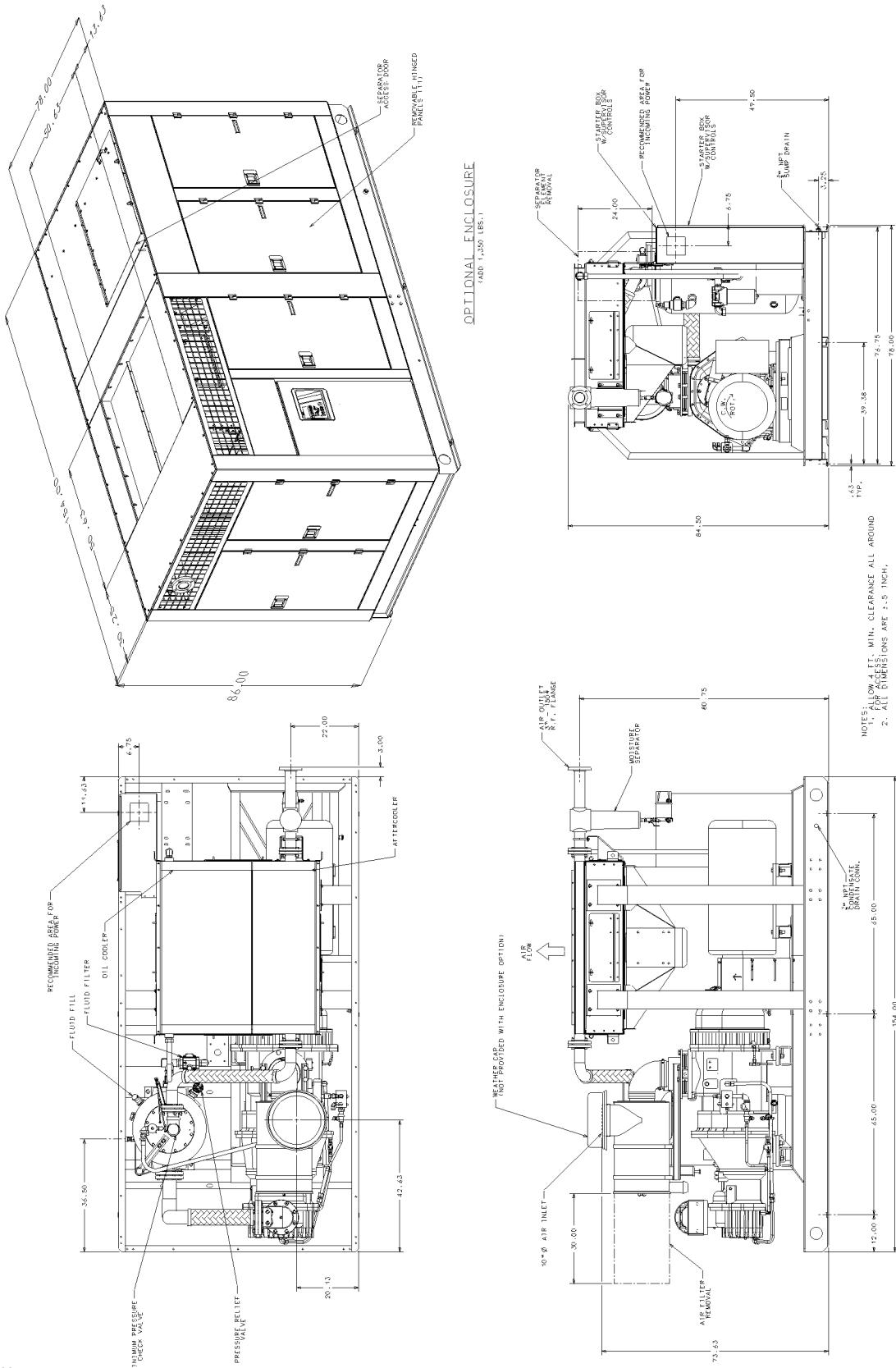

Section 3 SPECIFICATIONS

Figure 3-2B Identification- TS-32 Water-cooled 200-250HP/ 149-186KW

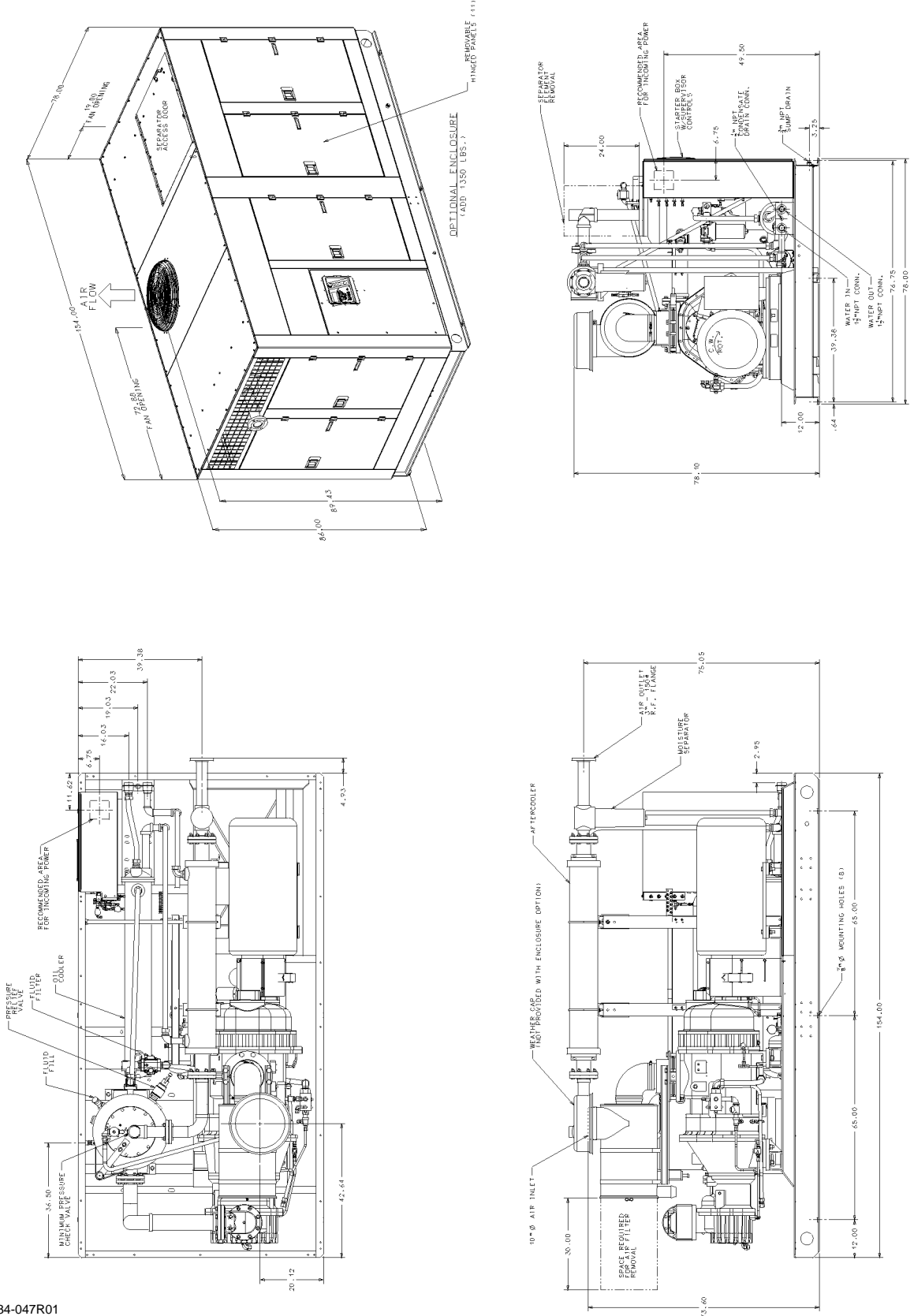

02250134-047R01

Section 3 SPECIFICATIONS

Figure 3-2C Identification- TS-32 Air-cooled 300-350HP/ 224-261KW

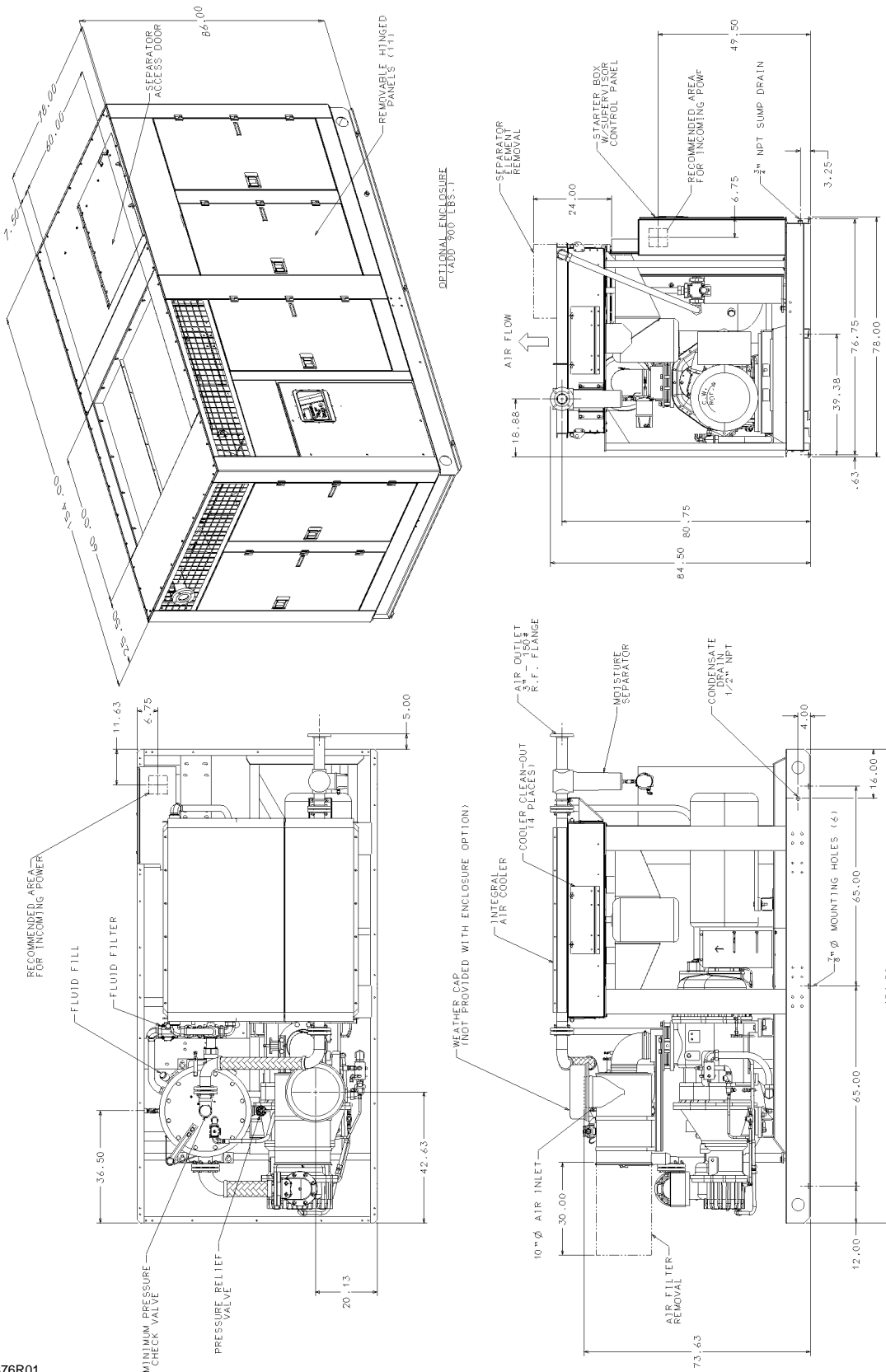

NOTES:
 1. ALLOW 4 FT. MIN. CLEARANCE ALL AROUND FOR ACCESS.
 2. ALL DIMENSIONS ARE ±.5 INCH.

Section 3 SPECIFICATIONS

Figure 3-2D Identification- TS-32 Water-cooled 300-350HP/ 224-261KW

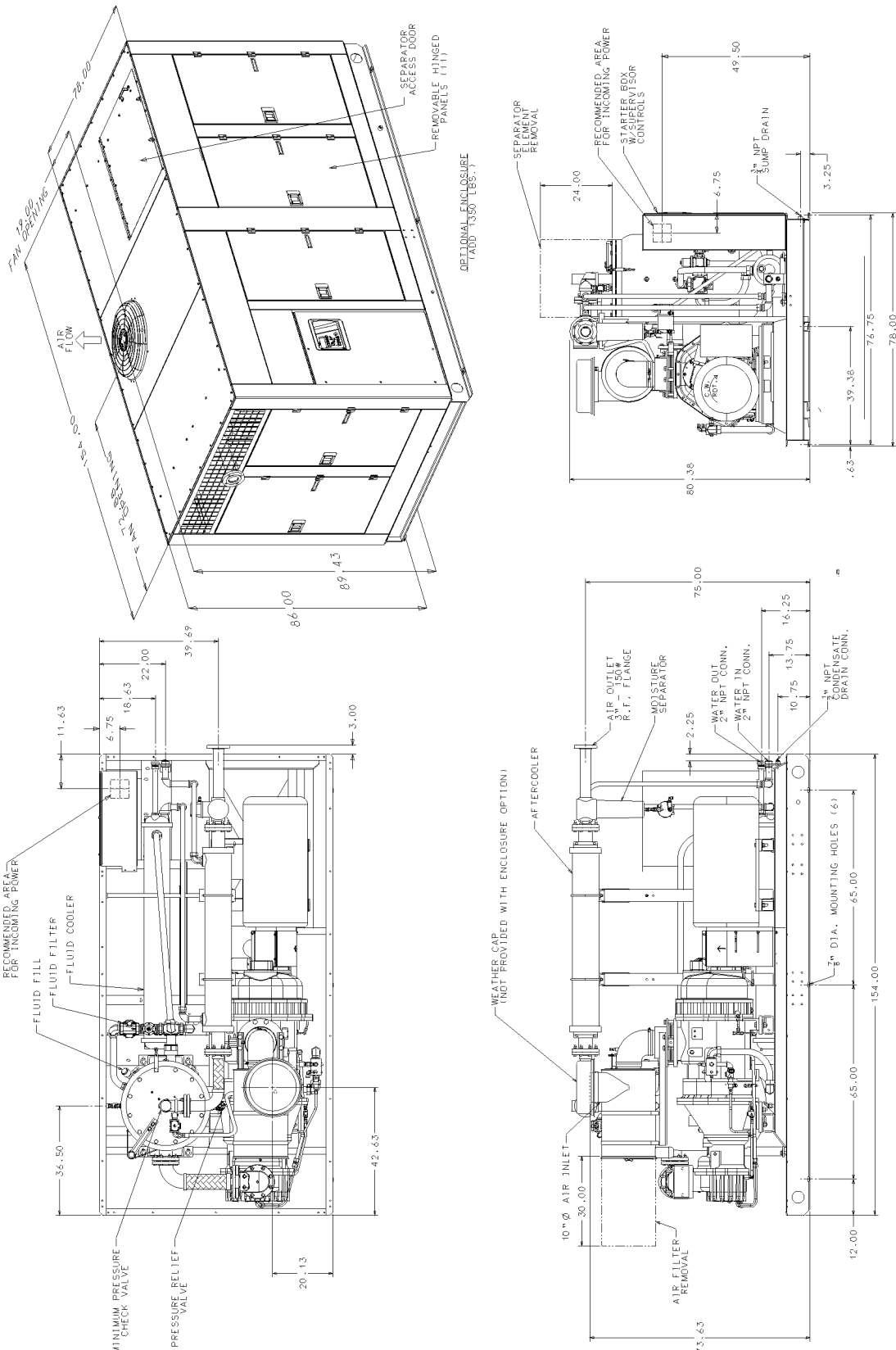

NOTES:
 1. ALLOW 4 FT. MIN. CLEARANCE ALL AROUND FOR ACCESS.
 2. ALL DIMENSIONS ARE ±.5 INCH.

02250126-378R01

Section 3 SPECIFICATIONS

Figure 3-3 Piping and Instrumentation

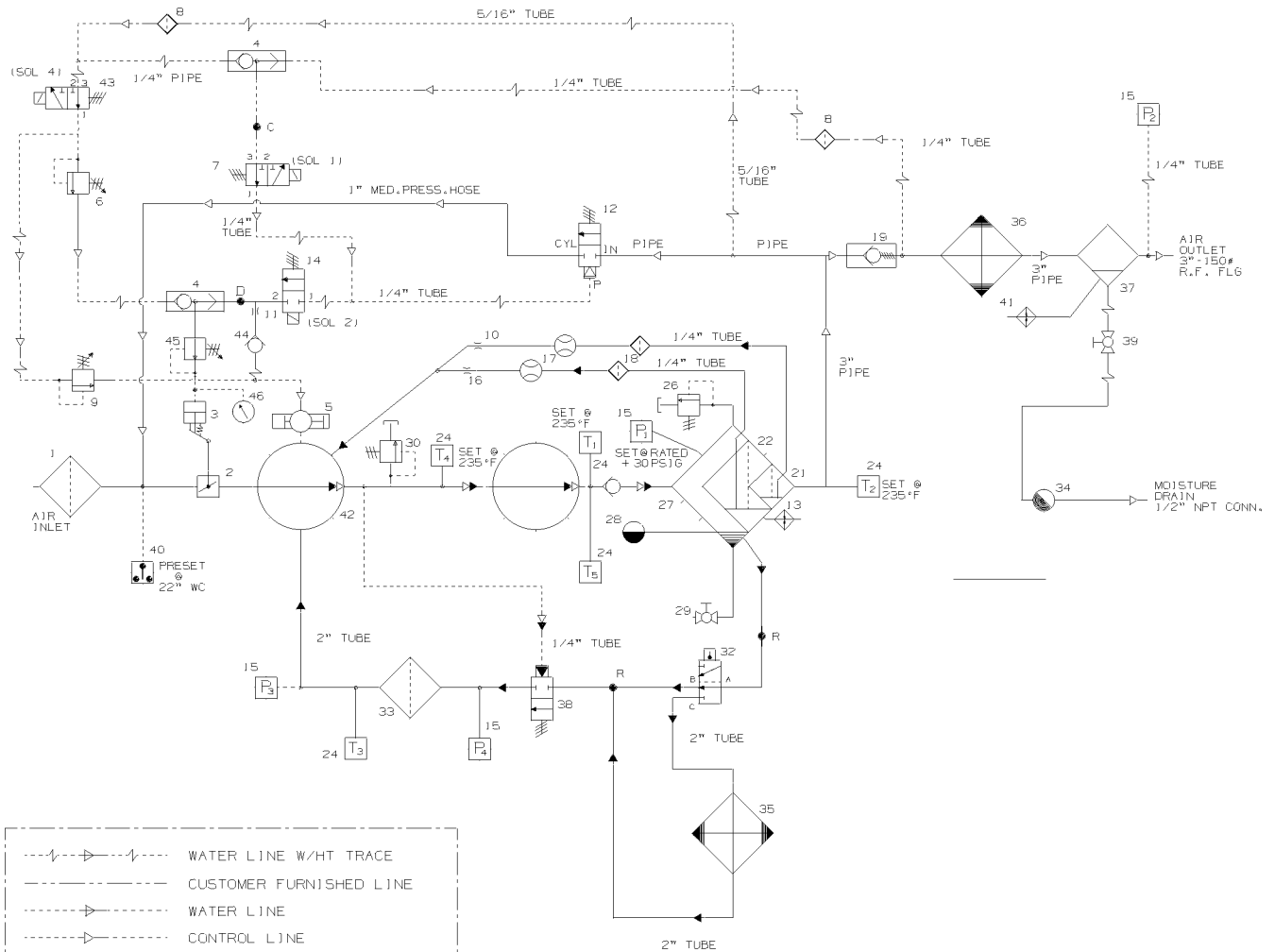

- NOTE:
1. PART NUMBERS ARE FOR REFERENCE ONLY. REFER TO BILL OF MATERIAL AND OR FACE OF ORDER FOR ACUTAL PARTS.
 2. SECTION BETWEEN LETTERED POINTS ARE TO BE REPLACED WITH CORRESPONDING OPTION PICTURED BELOW, AS REQUIRED BY FACE OF ORDER.
 3. HEAT TRACE SHOWN AS OPTIONAL. CHECK FACE OF ORDER FOR HEAT TRACE REQUIREMENTS.
 4. REHEATERS 1.50NPT CONNECTION PORTS LABELED "R" QUANTITY OF TWO LOCATIONS.

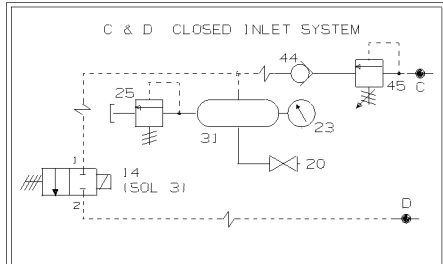

DERIVED FROM: 02250133-234R3

Section 3 SPECIFICATIONS

Figure 3-3 Piping and Instrumentation

<i>key number</i>	<i>description</i>	<i>part number</i>	<i>quantity</i>
1	filter, assy air inlet (heavy duty)	250006-718	1
2	vlv , inlet butterfly 10"	02250126 -220	1
3	control, sullicon ls25s	011682-003	1
4	vlv, shuttle 1 /4"	408893	2
5	vlv, spiral	-	1
6	vlv, diff. press. reg. 1/4" npt	406929	1
7	vlv, sol 3w no 1/4" 115v ac	02250125-657	1
8	filter, control 1 /4" npt	02250112 -032	2
9	vlv, press. reg.	408275	1
10	orifice, .032"	02250125-774	1
11	orifice, .03"	02250101-191	1
12	vlv, blowdown 1/2" nc 2-way	409783	1
13	heater, sump	047226	1
14	vlv , solenoid 1 /4" 2 -way	02250125 -679	2
15	pressure transducer n4	02250078-933	4
16	orifice, .094	02250125-776	1
17	glass, sight 1 /4"	02250126 -129	2
18	strainer, in line sae	02250117-782	2
19	vlv, min. press. check 3" npt	250033-821	1
20	vlv, moisture bleed	041111	1
21	element, secondary separator	250034-129	1
22	element, primary separator	250034-123	1
23	gauge, pressure	02250117-009	1
24	probe, 100 ohm rtd 20'	02250044-985	4
25	vlv, relief 1/2" 150psi	02250092 -138	1
26	vlv, relief 1 -1/2" 210#	02250048-966	1

(Continued on page 25)

Section 3 SPECIFICATIONS

Figure 3-3 Piping and Instrumentation

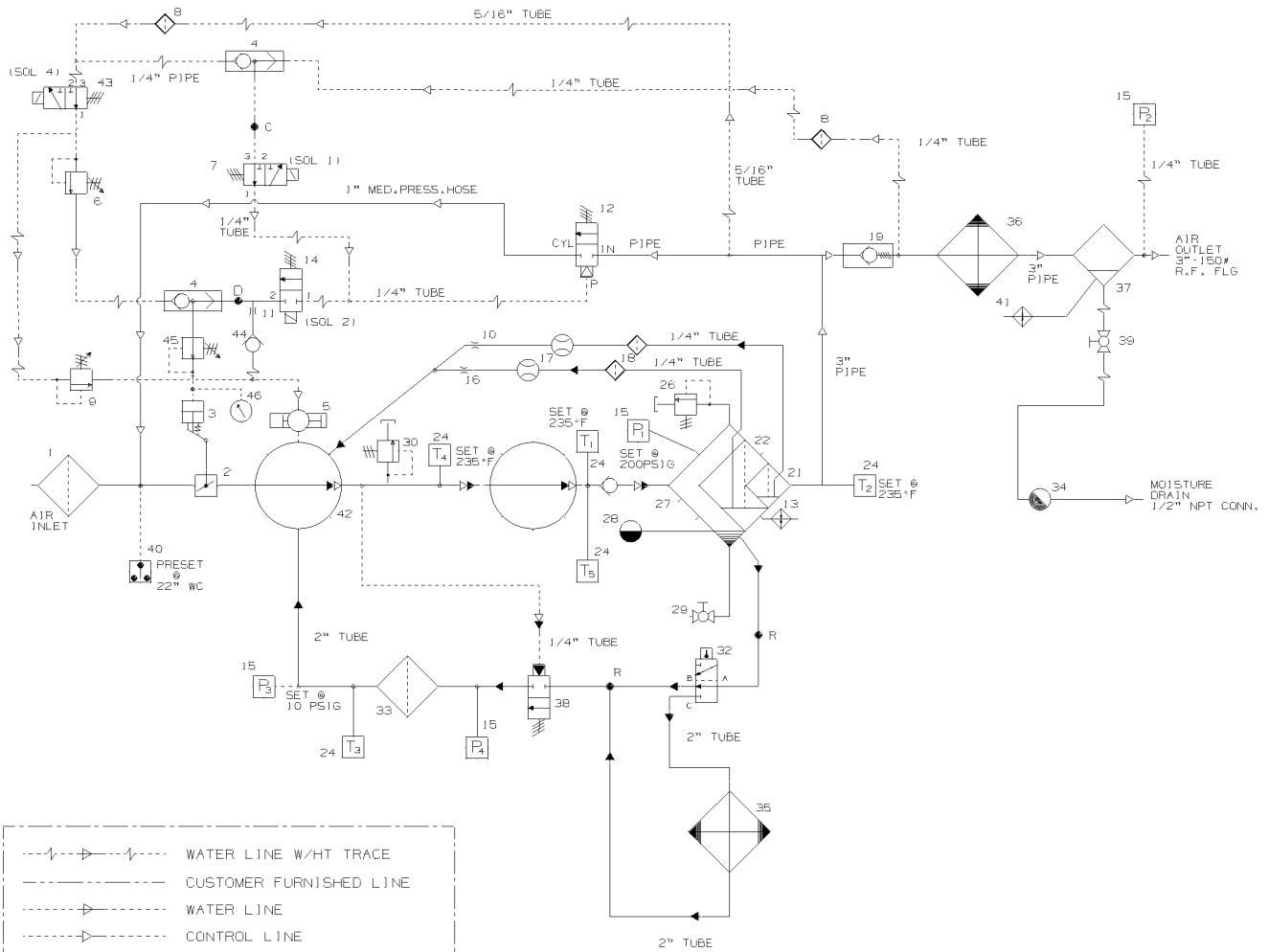

- NOTE:
1. PART NUMBERS ARE FOR REFERENCE ONLY. REFER TO BILL OF MATERIAL AND OR FACE OF ORDER FOR ACUTAL PARTS.
 2. SECTION BETWEEN LETTERED POINTS ARE TO BE REPLACED WITH CORRESPONDING OPTION PICTURED BELOW, AS REQUIRED BY FACE OF ORDER.
 3. HEAT TRACE SHOWN AS OPTIONAL. CHECK FACE OF ORDER FOR HEAT TRACE REQUIREMENTS.
 4. REHEATERS 1.50NPT CONNECTION PORTS LABELED "R" QUANTITY OF TWO LOCATIONS.

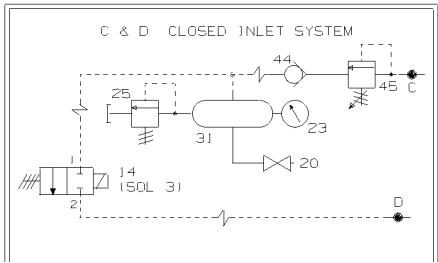

Section 3 SPECIFICATIONS

Figure 3-3 Piping and Instrumentation (continued)

<i>key number</i>	<i>description</i>	<i>part number</i>	<i>quantity</i>
27	tank, fluid sep.	02250132-854	1
28	glass, fluid level sight	02250097-611	2
29	vlv, ball 3/4"	02250125-221	1
30	vlv, relief 60# 2" x 2 -1/2"	250029-330	1
31	tank, accumulator 415 cu. in.	242221	1
32	vlv, thermal assy w/sae ports	02250127-962	1
33	filter, fluid	02250128-717	1
34	trap, condensate 3/4"	042034	1
35	cooler, fluid w/1-7/s"-12 sae oil ports	02250122-217	1
36	aftercooler, air to air	02250133-021	1
37	separator, combo trap	02250111-105	1
38	vlv, oil stop w/sae ports	02250122-004	1
39	vlv,ball 1/2" npt	047117	1
40	switch, v ac. 22" w. c. n4	02250078-249	1
41	heater, moisture separator	02250087-631	1
42	unit, compressor	-	1
43	vlv, sol 3w no 1/4" sequencing	02250125-657	1
44	vlv, check 1/4"	02250110-557	2
45	regulator,press 2-150#	046556	2
46	ga,air press 0-200psi	02250117-009	1

NOTES

Section 4 INSTALLATION

4.1 MOUNTING OF COMPRESSOR

A foundation or mounting capable of supporting the weight of the compressor, and rigid enough to maintain the compressor frame level and the compressor in alignment is required. The compressor frame must be leveled and secured with foundation bolts, and full uniform contact must be maintained between the frame and foundation. It is recommended that the frame be grouted to the foundation. The compressor unit and driver must be aligned after installation as specified in the Operator's Manual. No piping loads shall be transmitted to the compressor or the cooling package at the external connections.

4.2 VENTILATION AND COOLING

For air-cooled compressors, select a location to permit sufficient unobstructed air to flow in and out of the compressor cooling package to keep the operating temperature stable. The minimum distance that the compressor should be from surrounding walls is three (3) feet (914mm). To prevent excessive ambient temperature rise, it is imperative to provide adequate ventilation.

For water-cooled compressors, it is necessary to check the cooling water supply. The water system must be capable of supplying the following flows:

<u>MODEL-HP/KW</u>	<u>WATER FLOW (GPM)</u>
TS-32 200HP/150KW	45
TS-32 250HP/187KW	54
TS-32 300HP/225KW	65
TS-32 350HP/260KW	76

NOTE

Water flow requirements are based on 80°F to 85°F (27°C to 29°C) water inlet temperature.

Recommended water pressure range is 40 to 75 psig (2.8 to 5.2 bar). Water flow rates will vary with operating conditions. For rates based on criteria other than that listed, consult your local Sullair representative.

Table 4-1 Ventilation Requirements below indicates the ventilation requirements necessary to keep the compressor running at a normal operating temperature. The fan air requirement is the volume of air which must flow through the compressor and/or cooling package for proper ventilation. The specified heat rejection requirement is the amount of heat that is radiated by the compressor. This heat must be removed to assure a normal operating temperature. With air-cooled compressors it is possible to use this heat for space heating, providing excessive pressure drop is not created across the fan. Consult a Sullair office for assistance in utilizing this heat.

DO NOT install a water-cooled or an air-cooled/aftercooled compressor without adequate freeze protection where it will be exposed to temperature less than 32°F(0°C).

4.3 SERVICE AIR PIPING

Service air piping should be installed as shown in Figure 4-1. A shut-off valve should be installed to isolate a compressor from the service line if required. Also notice that the service line should be equipped with water legs and condensate drains throughout the system.

4.4 COUPLING ALIGNMENT CHECK

In preparation for the factory test, the coupling supplied with your compressor is properly aligned for operation. After the compressor package has been mounted to a foundation, it is necessary to recheck the coupling alignment. Refer to Coupling Alignment procedure explained in the Maintenance section of this manual.

4.5 FLUID LEVEL CHECK

Your air compressor is also supplied with the proper amount of fluid. However, it is necessary to check the fluid level at installation. The level is checked by looking at the sight glass located on the sump. If the sump is properly filled, the coolant level should fill 1/2 of the upper sight glass when the

Table 4-1 Ventilation Requirements

		WATER COOLED OR REMOTE COOLED COMPRESSOR PACKAGE		AIR-COOLED (I) COOLING PACKAGE	
MODEL	MOTOR HP/KW	HEAT REJECTION BTU/HR	VENT FAN FLOW (II) CFM	HEAT REJECTION BTU/HR	AIR FLOW CFM
TS-32-200	200/150	47,620	4150	560,200	18,000
TS-32-250	250/187	57,360	4150	674,800	18,000
TS-32-300	300/225	64,170	4150	802,100	28,000
TS-32-350	350/260	74,320	4150	929,000	31,000

(I) Applicable to air-cooled models only.

(II) Applicable to compressors with enclosure.

Section 4 INSTALLATION

Figure 4-1 Service Air Piping (Typical Installation)

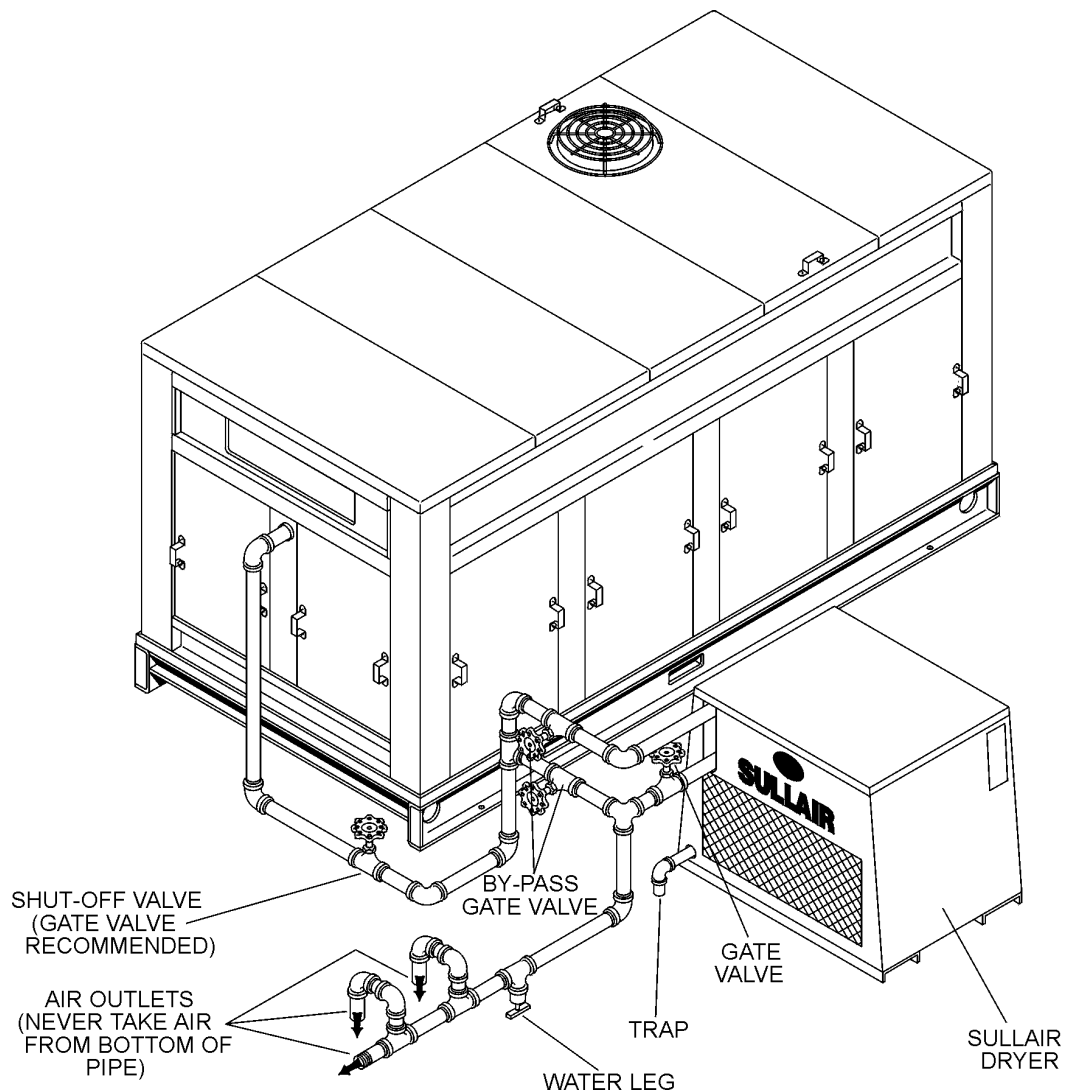

compressor is shutdown. When the oil level falls below the center of the lower sight glass, fluid must be added.

4.6 FLUID PIPING (REMOTE AIR-COOLED OPTION ONLY)

To allow de-pressurization of the cooling package and connecting piping between the compressor and the cooling package upon shutdown of the compressor, a 1/2" (13 mm) de-pressurization line must be installed between the top of the fluid cooler and the sump tank connection which is located on the fluid supply and return line connection bracket. This line must be maintained at a higher level than the supply and return piping for the fluid cooler.

The supply and return piping for the fluid cooler must be adequately sized to prevent excessive

pressure drop. The total pressure drop in the supply and return piping and associated fittings and valves shall not exceed 10 psig (0.7 bar) at the worst case operating condition (usually lowest ambient). If the pressure drop is in excess of 10 psig (0.7 bar), a pump should be installed. Consult the Sullair Service Department for recommendations.

It is recommended that shutoff valves be installed in the supply and return piping to facilitate compressor component's maintenance.

Because of the variability in installations, the fluid necessary to fill the supply and return piping for the fluid cooler is not part of the standard scope of supply for the compressor. The fluid necessary to fill this piping may be ordered from the nearest Sullair representative or the representative from whom the

Section 4 INSTALLATION

compressor was purchased. To assist in determining the amount of fluid necessary to fill the piping, the following chart may be used.

<u>PIPE SIZE</u>	<u>GALLONS/LITERS OF FLUID PER 12 INCHES/304.8MM OF PIPE</u>
2	.1635/.62
2 1/2	.2555/.97
3	.368/1.39
4	.6542/2.48
6	1.4719/5.57

4.7 ELECTRICAL PREPARATION

Interior electrical wiring is performed at the factory. Required customer wiring is minimal, but should be by a qualified electrician in compliance with OSHA, National Electrical Code, and any other applicable state or local electrical code concerning isolation switches, fuse disconnects, etc. Sullair provides a wiring diagram for use by the installer.

A few electrical checks should be made to help assure that the first start-up will be trouble free.



Lethal shock hazard inside.

Disconnect all power at source, before opening or servicing starter or control panel.

1. Check incoming voltage. Be sure that the incoming voltage is the same voltage that the compressor was wired for.
2. Check starter and overload heater sizes (see Electrical Parts in Parts Manual).

3. Check all electrical connections for tightness.

4. "DRY RUN" the electrical controls by disconnecting the three (3) motor leads from the starter. Pull out the EMERGENCY STOP button on the control panel and press

NOTE

Since some solid state starters have built-in power monitoring, a dry run will only indicate compressor overload when machine has this type of starter.

5. Reconnect the three (3) motor leads and jog the motor for a direction of rotation check, as explained in Section 4.8.

4.8 MOTOR ROTATION DIRECTION CHECK

After the electrical wiring has been done, it is necessary to check the direction of the motor rotation. With the control system in MANUAL mode, press the and pads in succession to bump start the compressor. When looking at the motor from the end opposite the compressor unit, the shaft should be turning clockwise on all gear driven models, and counterclockwise on direct drive models. If the motor shaft is not turning in the proper direction, disconnect the power to the starter and exchange any two of the three power input leads, then recheck rotation. A "Direction of Rotation" decal is located on the coupling guard between the motor and compressor to show proper motor/compressor rotation.

Section 5 SUPERVISOR

Figure 5-1 Supervisor Control Panel

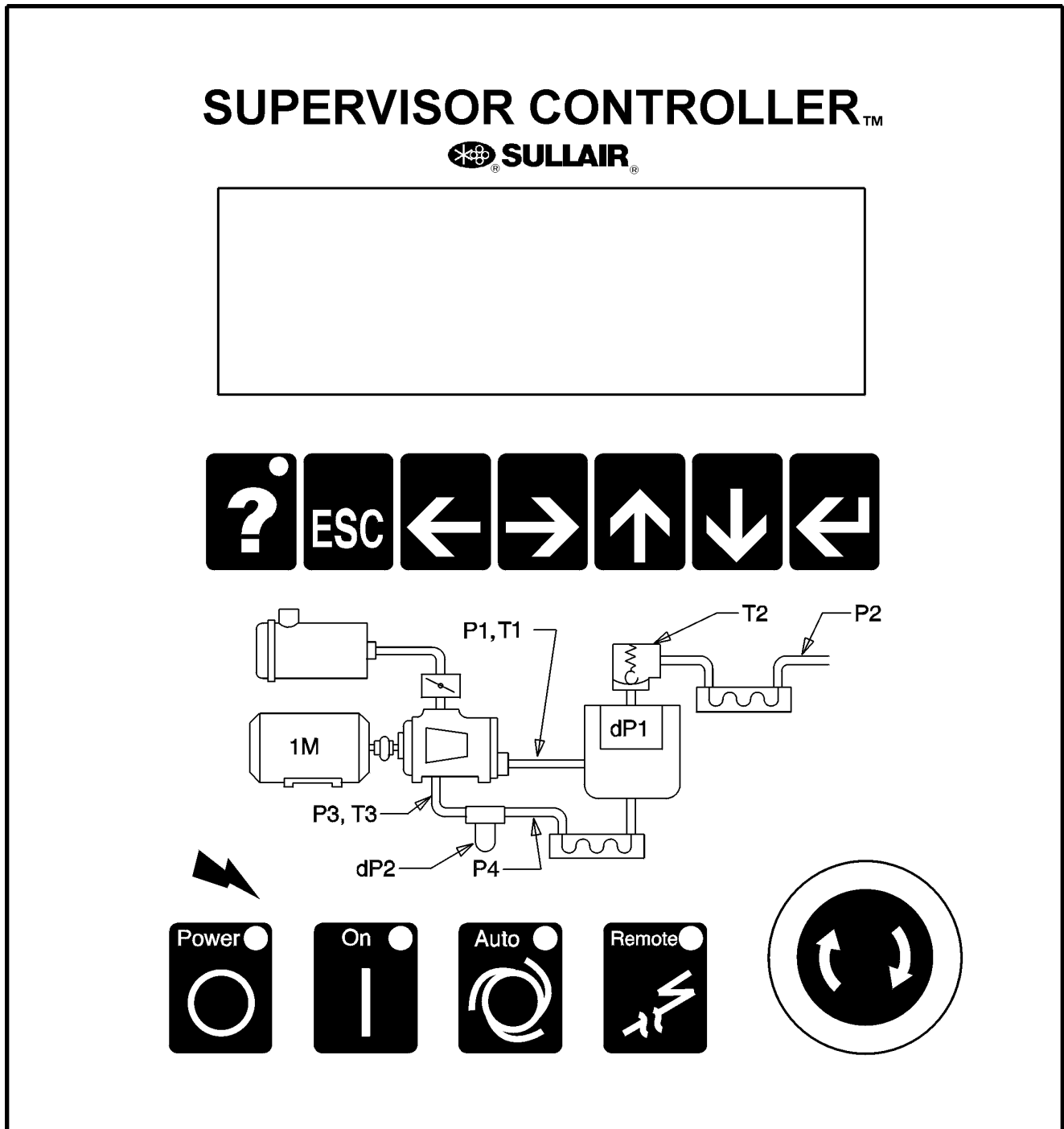

5.1 SUPERVISOR KEYBOARD LAYOUT

Refer to Figure 5-1. The Display module has eleven keys grouped in two rows.

The top row has the following seven keys :



- Help key, used to display possible causes of and correction for an alarm or fault.



- Returns to main display.



-Used to edit text or numbers (move cursor left).



- Used to edit text or numbers (move cursor right).



- Used to change numbers or text, or scroll.



- Used to change numbers or text, or scroll.



- Used to select an item from a menu, or start and end an edit on a parameter

The bottom row has four keys :



- Stop, stops machine. Clears fault and warning if machine is stopped, and conditions have been eliminated.



- Run, starts machine. Clears warnings if machine is running.



- Toggles auto mode.



-Toggles Local/Remote mode. This can be used to disable sequencing.

5.2 MAIN DISPLAY

Line 1 - Machine state :

E-Stop - E- Stop button pressed, or auxiliary e-stop present.

Stopped - Machine not running.

Unloaded - Machine running unloaded.

Loaded - Machine running, loaded and modulating.

Full Load - Machine forced to full load.

Remote Stop - Compressor is off but armed to start. The machine will start when the remote start contact is closed. **NOTE** : the machine may start at

any time.

Seq Stop - Compressor is off but armed to start. The machine will start when the sequencing conditions meet the criteria to start. **NOTE**: the machine may start at any time.

Line 2 - Fault or Warning, blank means no fault or warning is present.

If there are multiple alarms, they will be shown for 2 seconds each. If an alarm is active, pressing the '?' key will give troubleshooting information on that alarm.

Line 3 - P2 - Line pressure

Line 4 - T1 - Discharge Temperature

5.3 FUNCTION MENU

While in the main display, if any of the arrow keys are pressed, the function menu is displayed. This menu is used to view status or edit parameters.

The function menu has the following entries :

Status - Current pressures, temperatures, inputs and outputs.

Control Parameters - Pressure and temperature and timer settings.

Maintenance - Preventive maintenance information and timers.

Fault Log - Log of previous faults.

Sensor Log - Log of sensor readings leading up to a fault.

Sequencing - Sequencing parameters.

System Display - Display of modes of machines in a sequencing system.

Calibration - Correction factors for pressures.

Factory Setup - Model settings.

Test - Used by Sullair personnel for troubleshooting

To select a function, use the up and down arrow keys to scroll to the desired function as indicated on

last line of display, then press the enter  key.

After entering a function, the information can be viewed by using the up and down arrow keys. If the function shows status then values cannot be changed. If the function displays parameters, then the values can be changed.

To change a value, scroll to the line to be changed using the up arrow and down arrow keys, and push the enter button. The value can be changed by using the up arrow or down arrow keys. When editing is finished, pushing the enter key will fix the

Section 5 SUPERVISOR

value. If during a change the ESC key is pushed, editing is terminated and the original value is reset.

The left and right arrow keys can be used to move to other digits or letters in a value. For example to change a value from 100 to 500, the left arrow key can be used to position the cursor to the 1 digit in the 100, and the up arrow key used to increment the digit to 5.

Text fields can also be edited in the same manner. Push the enter key to start the edit, use the left and right arrow keys to move to the letter to be changed, then use the up and down arrow to change the letter. Push the enter key to complete the edit.

The following are detailed descriptions of the various displays.

5.4 STATUS - CURRENT PRESSURES, TEMPERATURES, INPUTS AND OUTPUTS

All inputs and outputs are displayed showing both the designator and the description (eg. T1-Discharge) along with the selected temperature (C or F) or pressure (psi, bar, kpa) units. Digital inputs and outputs are shown either as a '0' (zero) or '1' (one). Zero is off and one is on. This is a view only display.

The order of display is :

Temperatures - T1 through T5 depending on model

Pressures - P1 through P4 depending on model

Delta pressures - dp1 through dp3 depending on model

Load Hours - Hours machine has run loaded

Run Hours - Hours machine has run loaded or unloaded

Load Cycles - Number of load/unload cycles

Starts - Number of time machine has started

E-Stop String - E-Stop push button.

Aux E-Stop - Auxiliary E-Stop, wired by customer.

Digital Inputs - D1 through D10, depending on model

Relay Outputs - K1 through K8, depending on model

5.5 CONTROL PARAMETERS - PRESSURE, TEMPERATURE AND TIMER SETTINGS

Parameters that control the operation of the machine are viewed and set using this display. These parameters may vary by machine model.

The Control Parameters are :

Unload pressure - The pressure where the machine is unloaded. For example if this parameter is set to 110 psi (7.6 bar) the machine will unload when the line pressure is above 110 psi (7.6 bar).

Load delta - The pressure differential below the unload pressure where the machine is loaded. For example if the unload pressure is set to 110 psi (7.6bar) and the load differential is set to 10 psid (0.7 bar), the machine will load when the line pressure goes below 100 psi (6.9 bar).

Unload Time - If the machine is running in AUTO mode, this parameter specifies the amount of time that the machine will run unloaded before shutting off. If the time is set less than 15 minutes (for example 5), there may be times when the machine will run unloaded for more than 5 minutes. This is because there is another timer that keeps the machine from being started more than four times an hour.

Drain Interval - If the machine has an optional electric solenoid drain, this parameter and the following parameter (Drain Time) are used to turn on the drain. The interval is the time between activations of the drain and the Drain Time is the length of the time energized. This does not apply to the Sullair SCD zero loss drain, which is not controlled or monitored by the Supervisor.

Drain Time - Length of time that drain is energized.

Restart time -



Enabling this function also enables automatic restart after power recovery. Be sure to depress the Emergency Stop button to defeat this function when automatic start is to be prevented.

Time to wait after power up before starting machine. This parameter is used to keep several machines from starting at the same time after power up, or to delay start until other equipment is started. If disabled parameter is zero, the machine will not automatically start after power up. If this parameter is a number larger than zero, the machine restarts after a delay defined by this time. For example, if the Restart Time is set to 10 seconds, then the machine will be enabled to start after 10 seconds.

Wye to delta transition timer - Also used to control the closed inlet start valve. Disable by setting to zero (0)-full voltage start (standard for full voltage start). Requires approximately 4-6 seconds for wye-delta or solid state starting.

Modulate - If set to "No" the spiral valve and inlet valve modulation control are disabled, and the

machine runs load/ no load. If modulate is set to "No", unload pressure must be reset to the rated load pressure of the machine. For example, for an L model rated for 100 psig full load operation, the unload pressure must be set at 100 psig. This ensures that the motor will not overload.

Language select - English, German, Spanish, Italian and French may be selected for display language.

Temp Units - Temperature units may be set to degrees F or degrees C.

Press Units - Pressure units may be set to psi, bar, or kPa.

5.6 MAINTENANCE - PREVENTIVE MAINTENANCE INFORMATION AND TIMERS

The following lines are on the Maintenance display.

Information - The top two lines may be changed to advise what to do when there is a maintenance warning. For example a distributor can put in his name and telephone number.

Ser. No - Serial number of machine

Warn at - When any one of the following drop below this number, a warning is issued.

Oil Filter hours - Hours before oil filter change

PN - Oil Filter part number

Separator hours - Hours before separator change

Prim. - Primary separator part number

Air Filter hours - Hours before air filter change

Prim. - Primary air filter part number

Sec. - Secondary air filter part number

Oil hours - Hours before oil change

PN - Oil part number

Oil Anal. - Hours before oil analysis

These hours and part numbers can be changed using the enter and arrow keys.

Fault Log - Log of previous faults.

The fault log shows the last 16 faults that occurred. The top line of the display shows the run hours where the fault occurred, and the second line shows the fault. The faults can be scrolled through using the up and down arrow keys. They are ordered by most recent first. (ie. when the function is entered the most recent fault is displayed. Pressing the down arrow displays the next fault etc).

Sensor Log - Log of sensor readings leading up to

a fault.

The sensor log shows the sensor readings leading up to a fault. The top line shows the last fault. The following lines show T1, T2, P1 & P2. Each line represents readings that are 5 seconds apart for one minute, then one minute apart for 10 minutes. There is a second set of readings for T3, T4, P3 & P4.

5.7 SEQUENCING - SEQUENCING & COMMUNICATION PARAMETERS

NOTE

Sequencing requires an optional communications module.

The following parameters can be viewed and edited. For more details on sequencing see the Supervisor Sequencing and Protocol Manual.

Sequence By - Sequencing mode can be set to:

Disabled - Control does not do any sequencing.

Remote - Enables Remote Start/Stop, Remote Load/Unload and Local/Master inputs

Hours - Uses the Seq Hrs parameter to determine order of sequencing

Number - Uses the Com Number to determine order of sequencing

Seq Hrs - This is an hour counter used when the 'Sequence By' parameter is set to 'Hours'. Each hour that the machine is running increments this counter. When then 'Sequence By' parameter is set to 'Hours', the machine with the least amount of Seq Hrs is started first, and the machine with the most Seq Hrs is shut off first.

Com Number - Communications number. When two or more machines are connected together using the network (RS-485 channel), each machine must have a unique number or address. These must be assigned in numerical order. For example in a three machine system the machine communications numbers should be 1,2 & 3.

Machines - This is the total number of machines connected to the network (RS-485 channel). For example in a three machine system, this parameter should be set to 3.

Low Press - This is the lowest pressure allowed before immediately starting a machine.

Recovery Time - This parameter keeps multiple machines from loading, unloading and starting at the same time. For example if a low pressure condition causes a machine to start, the next machine will not start unless the Recovery Time has elapsed,

Section 5 SUPERVISOR

and the pressure has not recovered (i.e. has risen over 'Low Press').

Rotate - This parameter is used only in very special cases.

NOTE

Leave this parameter disabled unless instructed by Sullair Service Personnel.

The only time this parameter should be used is in a situation where, once a machine is started, it never stops (ie. the unload timer never expires). This can happen when the load matches the output of the machine, all the time. In this case the machine will never unload and shut off. The rotate forces the machine to stop after it's Seq Hrs. are greater than the other machines. For example in a two machine system, with Rotate set at 100 hrs. The machine that is running will shut off when the Seq Hrs. are 100 more than the machine that is stopped.

Minute, Hour, Day, Month, Year- If the Communications Module is present in the system, the time and date can be set using these parameters.

5.8 SYSTEM DISPLAY - DISPLAY OF MODES OF MACHINES IN A SEQUENCING SYSTEM

Note that this display is only applicable when there are two or more machines connected to the communications network (RS-485) and the Sequence By parameters on each machine are set to 'Hours' or 'Number'.

The columns are described below
Communication Number

Status -

- E - Emergency Stop
- M - Manual stop
- R - Remote stop
- B - Standby
- S - Starting
- U - Unloaded
- L - Loaded
- T - Trim machine
- F - Full load

Sequencing Hours

Capacity - Not used at this time

Local System Pressure - Pressure read by machines' pressure transducer

The top line is a legend that describes each column. The right hand number on the top line is the system pressure. The system pressure is the highest pressure reading of all the machines. Note that the local pressure readings can be used to determine what

machines may need to be calibrated. The system pressure transducers on all machines should read within 1 psi of one another. The calibration function can be used to set the readings to be the same.

5.9 CALIBRATION - CORRECTION FACTORS FOR PRESSURES

The first line of this display is the password. If the password is 0 then the following parameters are not protected and can be changed. If the password is non-zero, then enter the displayed number plus 4 to enable changing the parameters. For example if the number displayed is 10 then changing the password to 14 will enable editing.

The four pressures P1, P2, P3 & P4 as well as the differential pressure dP1 can be calibrated. The number on the right hand side of the line is added to the transducer reading to give the calibrated reading. The calibrated reading is shown in the middle of the line.

There are also two other parameters in the calibration function :

Protect - When set to yes, protects the control parameters from change.

Fault on Warn - Force fault on warning.

Force Unload - When set to yes, forces the machine to unload.

5.10 FACTORY SETUP- Model settings.

The factory setup display is used by Sullair personnel to initially set up the machine. The following values may be set.

Set Defaults -

NOTE

Do not change this parameter unless requested by Sullair Service Department.

This parameter is used to clear all user-entered or model-specific inputs and parameters, as well as any accumulated hours.

This can be used to set all factory, control and sequencing parameters to factory defaults. If this is the first time the Supervisor has been powered up (as in initial installation at the factory, or replacement in the field) then this should be set to 'Yes'. After setting to 'Yes' the parameters will be set to factory defaults and the parameter will return to 'No'.

WARNING

Any subsequent use of this setting will clear all user-entered or model-specific inputs and the parameters as well as any accumulated hours.

Section 5 SUPERVISOR

Model - Model number of machine.

Cooling - Air or Water

Press Trans - Pressure transducer range 200, 250, 500

P1 Max - Maximum discharge pressure

Water Switch - Water pressure switch, Yes or No

Oil Switch - Oil pressure differential switch, Yes or No

Stop Timer - Time to run machine before stopping.

Protect - Protect control parameters

Load Hours - Hours machine was running and loaded

Run Hours - Hours machine was running loaded and unloaded

Load Cycles - Number of load/unload cycles

Starts - Number of machine starts

Capacity - Maximum capacity of machine

5.11 TEST- Used by Sullair personnel for troubleshooting.

5.12 TROUBLESHOOTING INTRODUCTION

The information contained in the Troubleshooting chart has been compiled from factory experience. It contains symptoms and usual causes for the described problems. However, **DO NOT** assume that these are the only problems that may occur. All available data concerning the trouble should be systematically analyzed before undertaking any repairs or component replacement procedures.

A detailed visual inspection is worth performing for almost all problems and may avoid unnecessary additional damage to the compressor. Always remember to:

- a. Check for loose wiring.
- b. Check for damaged piping.
- c. Check for parts damaged by heat or an electrical short circuit, usually apparent by discoloration or a burnt odor.

Should your problem persist after making the recommended check, consult your nearest Sullair Distributor or the Sullair Corporation factory Service Department.

5.13 TROUBLESHOOTING GUIDE-SUPERVISOR CONTROLLER

MESSAGE	MODEL	ENABLE	PROBABLE CAUSE	REMEDY
Air Filter Maint	ALL	ALWAYS	Pressure Across Inlet Filter High	Replace filter.
	ALL	ALWAYS		Check inlet filter pressure switch.
Aux Motor Overload	ALL	ALWAYS	Auxiliary Motor Tripped on Cooling Fan, Oil Pump or Other Motor	Reset auxiliary overload after heater element cools.
	ALL	ALWAYS		Check motor starter contact for proper operation.
	ALL	ALWAYS		Check line voltage, if low consult power company.
E-Stop	ALL	ALWAYS	E-Stop Button Active	Release button.
E-Stop Push Button	ALL	ALWAYS		Check wiring.
E-Stop	ALL	ALWAYS	Auxiliary E-Stop String Open	Check auxiliary E-Stop devices.
E-Stop String	ALL	ALWAYS		Check wiring.
Low Water Pressure	ALL	Watercooled	Cooling Water Pressure Below 10 psi (0.7bar)	Check for closed valves or broken pipes.
Oil Change Due, Oil Filter Change, Separator Change Due, Air Filter Change, Oil Analysis Due	ALL	ALWAYS	Maintenance Due	Select Maintenance from menu to see service due and part numbers.
Main Motor Overload	ALL	ALWAYS	Main Motor Overload	Reset overload after heater element cools down.

Section 5 SUPERVISOR

5.13 TROUBLESHOOTING GUIDE-SUPERVISOR CONTROLLER (CONTINUED)

MESSAGE	MODEL	ENABLE	PROBABLE CAUSE	REMEDY
Main Motor Overload (continued)	ALL	ALWAYS		Make sure unload pressure set below limit of compressor
	ALL	ALWAYS		Check motor starter contacts for proper operation.
	ALL	ALWAYS		Check line voltage, if low consult power company.
I/O Mod Com Error, Com Mod Com Error, Motor Mod Com Error	ALL	ALWAYS	Module Network Error; The Network that Connects the Display Module, I/O Module and Other Optional Modules is Not Working Correctly	Check wiring.
	ALL	ALWAYS		Replace module referred to in error message, if problem persists replace display module.
Oil Filter Maint., dP2 Oil Filter High	ALL	ALWAYS	Pressure Across Oil Filter Above 20 psi (1.4 bar) while running	Oil filter clogged, replace oil filter.
	FLOODED	ALWAYS		Low ambient temperature, sump heater may be required in ambients below 40°F (4°C).
	ALL	ALWAYS		Sensor failure, check sensor, wiring and tubing.
P3 Oil Pressure Low, P3 Oil Pressure Low, dP3 Oil Pressure Low	ALL	ALWAYS	Oil Pressure Low	Oil pump failure, consult Sullair service department.
	FLOODED	ALWAYS		Oil filter clogged, replace filter.
	FLOODED	ALWAYS		Sump oil level low, replenish oil to proper level.
	FLOODED	ALWAYS		Low ambient temperature, sump heater may be required in ambients below 40°F (4°C).
P1 Sensor Fail, P2 Sensor Fail, P3 Sensor Fail, P4 Sensor Fail, T1 Sensor Fail, T2 Sensor Fail, T3 Sensor Fail, T4 Sensor Fail, T5 Sensor Fail	ALL	ALWAYS	Sensor or Wiring Failure	Check sensor wiring.
				Check sensor.
dP1 Separator Maint. P1-P2	FLOODED	ALWAYS	Pressure Across Separator High	Plugged separator elements, replace.
				Pressure sensor failure, check sensor wiring.
Factory Setup Error	ALL	ALWAYS	The Factory Setup Information Needs to be Reviewed for Correct Values	If problem persists replace Supervisor.
P1 Sump Pressure High	FLOODED	ALWAYS	Sump Pressure High	Sullicon, spiral or blowdown valve failed, check valves.

Section 5 SUPERVISOR

5.13 TROUBLESHOOTING GUIDE-SUPERVISOR CONTROLLER (CONTINUED)

MESSAGE	MODEL	ENABLE	PROBABLE CAUSE	REMEDY
P1 Sump Pressure High (continued)	ALL	ALWAYS	Sump Pressure High (cont.)	Solenoid valves, check operation and wiring.
	ALL	ALWAYS		Pressure regulator, check adjustment and operation.
	ALL	ALWAYS		Check minimum pressure check valve.
P1 Sump Pressure Low	FLOODED	ALWAYS	Sump Pressure Low	Check pressure sensor, wiring and tubing.
	FLOODED	ALWAYS		Machine may have failed to start.
T1 Interstage High, T2 Discharge High, T3 Oil Temp High, T4 Intercool High, T5 Discharge High, T1 Discharge High, T2 Dry Side High, T3 Oil Temp High, T4 Interstage High	ALL	ALWAYS	High Temp. Fault	Ambient above 105°F (41°C), improve local ventilation.
	FLOODED	ALWAYS		Fluid level low, replenish to proper level.
	FLOODED	ALWAYS		Thermal valve, check operation.
	ALL	Aircooled		Cooler fins dirty, clean fins and fan.
	ALL	Watercooled		Low water flow, check for valve closed, pump off or broken pipe.
	ALL	Watercooled		High water temperature, increase flow or lower water temperature.
	ALL	Watercooled		Cooler plugged, clean tubes and shell, if plugging persists, use cleaner water.
	ALL	ALWAYS		Sensor failure, check sensor and wiring.

Section 5 SUPERVISOR

Table 5-1 Alarms

Sensor	Type	Limit	Delay	Start Delay	Run Check (*)	Comment
System Check	On Fault	0	0	0	Constantly	Factory Setup Check Sum Fail
I/O Module Check	On Fault	0	0	0	Constantly	Communication failure I/O Module
Com Module Check	On Fault	0	0	0	Constantly	Communication failure Com Module
Motor Module Check Module	On Fault	0	0	0	Constantly	Communication failure Motor
D_1	On Fault	0	1	1	Constantly	Motor overload
D_2	On Fault	0	1	1	Constantly	Aux motor overload
D_3	On Warn	0	5	5	When Running	Air filter maintenance
D_4	On Fault	0	5	5	When Running	Low water pressure
E_1	On Fault	0	0	0	Constantly	E-Stop Push Button
E_2	On Fault	0	0	0	Constantly	Auxiliary E-Stop
AIR FILTER MAINT.	Maint Warn	0	0	0	If Enabled	Air Filter change due
OIL ANALYSIS Check	Maint Warn	0	0	0	If Enabled	Oil Analysis due
OIL CHANGE Check	Maint Warn	0	0	0	If Enabled	Oil change due
OIL FILTER MAINT.	Maint Warn	0	0	0	If Enabled	Oil filter change due
SEPARATOR CHANGE Check	Maint Warn	0	0	0	If Enabled	Separator change due
dP_1	High Warn	10	5	55	Over Min Psi	Separator maint P1-P2
dP_2	High Warn	20	5	2	When Running	Oil filter maint P4-P3
dP_3	Low Fault	1	5	55	When Running	Low Oil psi P3-(P1/2.5)
dP1Max	High Fault	0	5	0	When Running	dP1Max = P1Max - P1
dP1Max	High Warn	3	5	0	When Running	dP1Max = P1Max - P1
P_1	High Inhibit	5	0	0	At Start	High sump psi at start
P_1	Low Fault	5	5	0	When Running	Immediate Fault
P_1	High Fault	500	0	0	Constantly	Sensor failure fault
P_2	High Fault	500	0	0	Constantly	Sensor failure fault
P_3	High Fault	500	0	0	Constantly	Sensor failure fault
P_4	High Fault	500	0	0	Constantly	Sensor failure fault
T_1	Low Fault	-40	0	0	Constantly	Sensor failure fault
T_1	High Warn	225	5	30	Constantly	Delayed for temp spikes
T_1	High Fault	235	5	30	Constantly	Delayed for temp spikes
T_1	High Warn	245	0	0	Constantly	Immediate Warning
T_1	High Fault	255	0	0	Constantly	Immediate Fault
T_1	High Fault	500	0	0	Constantly	Sensor failure fault
T_2	Low Fault	-40	0	0	Constantly	Sensor failure fault
T_2	High Warn	225	5	30	Constantly	Delayed for temp spikes
T_2	High Fault	235	5	30	Constantly	Delayed for temp spikes
T_3	Low Warn	-40	0	0	Constantly	Sensor failure warning
T_3	High Warn	500	0	0	Constantly	Sensor failure warning
T_4	Low Fault	-40	0	0	Constantly	Sensor failure fault
T_4	High Fault	500	0	0	Constantly	Sensor failure fault

(*) In the 'Check' column above, alarms are checked :

Constantly - if machine running or stopped

When Running - if machine is running

If Enabled - if parameter is non-zero

At Start - will not allow start if alarm present

Over Min Psi - machine is loaded and above min load pressure

Section 6

COMPRESSOR OPERATION

6.1 INTRODUCTION

While Sullair has built into the TS-32 Series package a comprehensive array of controls and indicators to assure its proper operation, the user should recognize and interpret readings which call for service or indicate the onset of a malfunction. Before starting the unit, the user should become familiar with the controls and indicators-their pur-

pose, location, and use.

6.2 PURPOSE OF CONTROLS

All Supervisor Controller related functions and indicators are presented in [Section 5.2](#), so please refer to that section for your information. Additional indicators and functions included in the package are as follows:

CONTROL OR INDICATOR	PURPOSE
EMERGENCY STOP SWITCH	Pushing in this switch, found adjacent to the Supervisor, cuts all AC outputs from the Supervisor and de-energizes the starter. A fault message (E STOP) is displayed by the Supervisor until the button is pulled out and the "O" pad is depressed.
THERMAL O/L RESET	Momentarily pushing this button, found on the starter's thermal overload element housing, re-closes the starter's contacts after a current overload takes place. Please be aware that the elements must be allowed to cool sufficiently before resetting.
SULLICON ACTUATOR	Actuates the inlet butterfly valve which throttles the air flow to the compressor inlet, in order to match air supply to the demand.
SPIRAL VALVE	Internally bypasses and controls the air flow capacity of the compressor, in order to match air supply to the demand.
PRESSURE REGULATOR (SULLICON)	Opens a pressure line between the sump and Sullicon Control allowing the Sullicon Control to regulate air delivery according to the air demand.
PRESSURE REGULATOR (WITH SPIRAL VALVE)	Opens a pressure line between the service line and the spiral valve actuator allowing the spiral valve to regulate air delivery according to air demand.
SOLENOID VALVE #1	Electrically actuated, 3-way valve which controls the flow of pneumatic logic signals. Used throughout package to: <ul style="list-style-type: none"> -Open the blowdown valve. -Load the Sullicon device/close the inlet butterfly valve during shutdown operation. -Open the spiral valve.
SOLENOID VALVE #2	Opens when the compressor starts; closes when the compressor is shut off. This prevents any air system loss and depressurizes the controls when the compressor is shut off.
DISCHARGE CHECK VALVE	Blocks the reverse flow of air/fluid through the compressor unit during shutdown.

Section 6

COMPRESSOR OPERATION

CONTROL OR INDICATOR (CONT.)	PURPOSE (CONT.)
MINIMUM PRESSURE VALVE	Maintains 50 psig (3.5 bar) in the receiver tank when the compressor is running loaded. Also incorporates a check valve, which prevents compressed air backflow from the system when unloaded or shutdown.
PRESSURE RELIEF VALVE	Vents the sump vessel to atmosphere before the compressed air pressure exceeds rated tank pressure. Its operation indicates fault with the Supervisor operation unload pressure set too high or failure of solenoid valve #1.
BLOWDOWN VALVE ASSEMBLY	Vents the sump vessel to atmosphere during unloading and shutdown.
THERMAL MIXING VALVE	Bypasses fluid flow around the cooler until the fluid reaches a temperature of 170°F, 77°C (195°F for water cooled KT and ≥ 150 psi/ 10.3 bar). Useful for fast warm-up during start. Maintains a minimum temperature during periods of low load or low ambient temperatures.
FLUID STOP VALVE	Blocks the flow of fluid to the compressor during shutdown, thus preventing the discharge of fluid through the compressor inlet pipework.
SUMP SIGHT GLASSES	Indicates level of lubricant in the sump. Located on the sump side, fluid level should be maintained at a level between the high and low sight glass.
SEPARATOR RETURN LINE SIGHT GLASSES	Indicate fluid flow in the separator return lines. Large flow should be visible during full load operation; little to no flow during unloaded operation. Sluggish flow during full load operation indicates the need to clean the strainers fitted to the return lines.
WATER PRESSURE SWITCH	De-energizes the starter, via the Supervisor, if the water pressure falls below 10 psig (0.7 bar). This switch is not adjustable. Used on water-cooled packages only.
DRAIN VALVES	Lubricant sump drain valve.

6.3 INITIAL START-UP PROCEDURE

The following procedure should be used to make the initial start-up of the compressor.

1. Read the preceding pages of this manual thoroughly.
2. Jog motor to check for correct rotation of fan (refer to [Section 4.8](#)).
3. Be sure that all preparations and checks described in the Installation Section have been made.
4. Open the shut-off valve to the service line.
5. Check for possible leaks in piping.
6. Slowly close the shut-off valve to assure proper nameplate pressure unload setting is correct. The compressor will unload at nameplate pressure. If adjustments are necessary, see Control System Adjustments.
7. Observe the operating temperature. If the operating temperature exceeds 200°F (93°C) [215°F (102°C) for water-cooled 24KT and ≥ 150 psi],

Section 6



COMPRESSOR OPERATION

the cooling system and installation environment should be checked.

8. Open shut-off valve to the service line.
9. Reinspect the compressor for temperature and leaks the following day.

6.4 SUBSEQUENT START-UP PROCEDURE

On subsequent start-ups, check that the proper level is visible in the fluid sight glass and simply

press the START  or AUTO MODE  button. When the compressor is running, observe the instrument panel and maintenance indicators.

6.5 SHUTDOWN PROCEDURE

To shut the compressor down, simply press the

STOP  button.

NOTES

Section 7 MAINTENANCE

7.1 GENERAL

As you proceed in reading this section, it will be easy to see that the Maintenance Program for the air compressor is quite minimal yet important. The use of the service indicators provided for the fluid filter, air filter and fluid separator, will alert you when service maintenance is required. When the maintenance message is displayed by the Supervisor Controller™, maintenance for that specific item is required. See instructions for each item in Section 7.7, Parts Replacement and Adjustment procedures.

7.2 DAILY OPERATION

Prior to starting the compressor, it is necessary to check the fluid level in the sump. Should the level be low, simply add the necessary amount. If the addition of fluid becomes too frequent, a simple problem has developed which is causing this excessive loss. See the [Troubleshooting Section \(7.8\)](#) under Excessive Fluid Consumption for a probable cause and remedy.

After a routine start has been made, observe the Supervisor control panel and be sure it monitors the correct readings for that particular phase of operation. After the compressor has warmed up, it is recommended that a general check of the overall compressor and Supervisor be made to assure that the compressor is running properly.

WARNING

DO NOT remove caps, plugs, and/or other components when compressor is running or pressurized.

Stop compressor and relieve all internal pressure before doing so.

7.3 MAINTENANCE AFTER INITIAL 50 HOURS OF OPERATION

After the initial 50 hours of operation, a few maintenance requirements are needed to rid the system of any foreign materials if any. Perform the following maintenance operations to prevent unnecessary problems.

1. Clean the return line strainers.
2. Clean the return line orifices.
3. Change the fluid filter element.
4. Clean the control line filters.

7.4 MAINTENANCE AFTER 1000 HOURS

After 1000 hours of operation, it will be necessary to perform the following:

1. Clean the return line strainers.
2. Lubricate the Sullicon Control linkage.
3. Replace the fluid filter element.

7.5 FLUID CHANGE

Standard models are filled with the long life lubricant Sullube.

Sullube should be changed under the following conditions, whichever occurs first:

1. Every 8000 hours.
2. Once a year.
3. As indicated by fluid analysis.

A fluid sample analysis at every 4000 hours is recommended. Return fluid to Sullair Corporation in Michigan City for free analysis. To facilitate this, a sample bottle is included with the compressor.

7.6 SEPARATOR MAINTENANCE

Replace the separator elements when a message is displayed or after one (1) year, whichever comes first. The separator elements must be replaced. **DO NOT** clean the separator elements.

7.7 PARTS REPLACEMENT AND ADJUSTMENT PROCEDURES

MAIN FILTER MAINTENANCE

Refer to Figure 7-1. The main filter (P/N 02250128-717) is located schematically between the compressor and the fluid stop valve. When servicing the main filter, shut the compressor down, be sure all pressure has been released, then follow the instructions below. For element replacement order kit number 02250121-657.

1. Drain the fluid from the canister by removing the bottom drain plug

Figure 7-1 Main Filter (P/N 02250128-717)

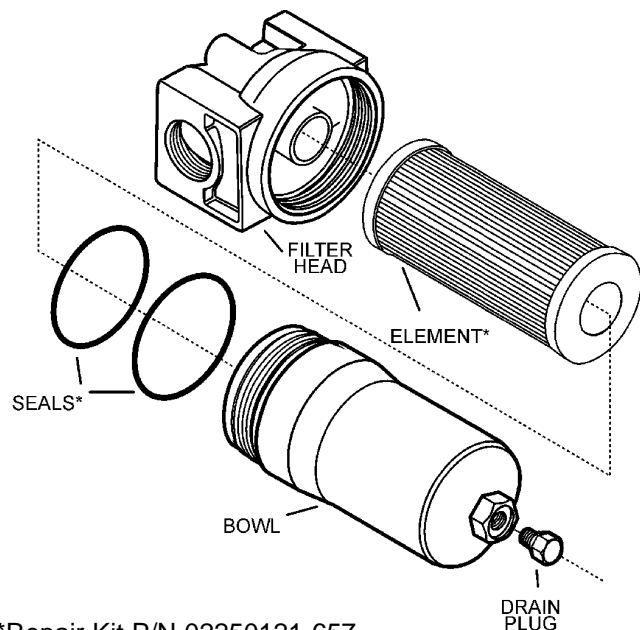

*Repair Kit P/N 02250121-657

Section 7 MAINTENANCE

2. Loosen the spin-on canister using a wrench on the bottom canister hex.
3. Pull the canister away from the filter head. The filter element will be attached to the head.
4. Separate the element from the head.
5. Remove the canister seals.
6. Thoroughly clean the filter head and canister in solvent.
7. Lubricate the new seals with the same type of fluid used in the compressor and position each seal in its appropriate place.
8. Slide the element into the canister.
9. Thread the canister and element back on the filter head.

AIR FILTER MAINTENANCE

Refer to Figure 7-2. Air filter maintenance should be performed when the air filter maintenance message is displayed. The air filter is equipped with a primary element and a secondary element. As previously stated, the Supervisor will alert you as to when the primary element maintenance is necessary. When removing the primary element, always check the secondary element for visible dirt, grease or damage. The secondary element must be changed after every sixth primary element change.

DO NOT clean the secondary element.

ELEMENT REMOVAL

1. Clean the exterior of the air filter housing.
2. Remove the cover assembly by loosening the wingnut securing it.
3. Pull the element assembly out of the housing.
4. On the inside of the element, you will notice a wingnut which fastens the element to the housing. Remove the wingnut and pull the primary element out.
5. Loosen and remove the hex nut securing the secondary element. Remove the secondary element.
6. Inspect the secondary element and replace if necessary.
7. Clean the interior of the housing by using a damp cloth. **DO NOT** blow dirt out with compressor air.
8. Install the new secondary element and replace the sealing washer and hex nut.
9. With the secondary element in place, replace the primary element.

DO NOT strike the element against any hard surface to dislodge dust. This will damage the sealing surfaces and possibly rupture the element.

Figure 7-2 Air Filter Replacement (P/N 250006-718)

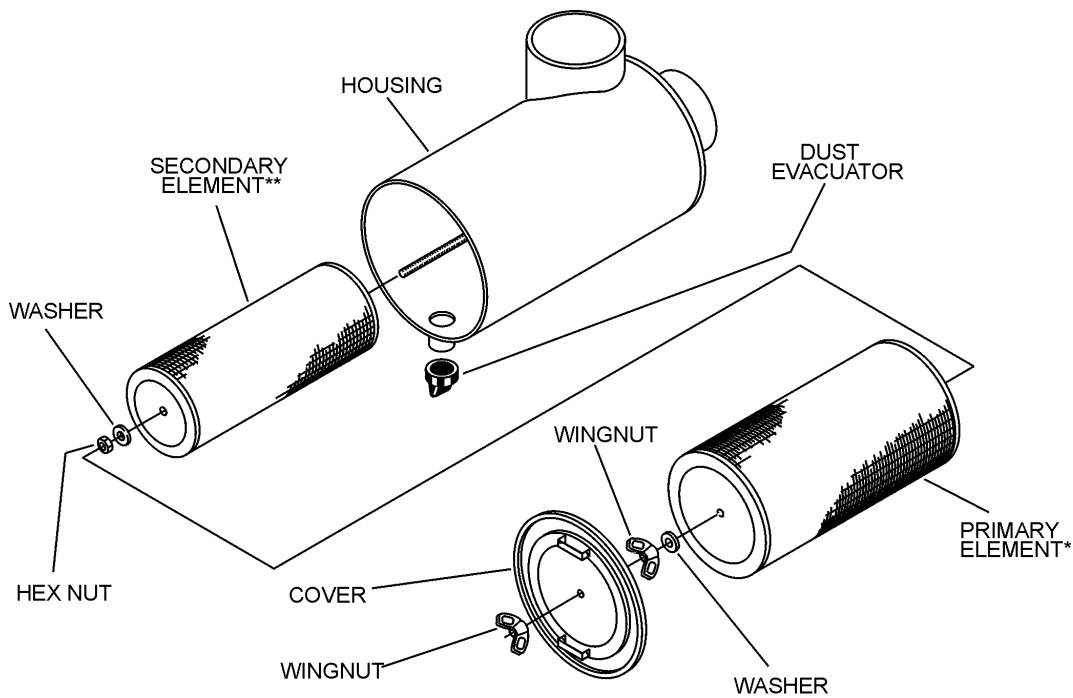

*Primary Replacement Element P/N 250007-838

**Secondary Replacement Element P/N 250007-839

Section 7 MAINTENANCE

Figure 7-3 Separator Element Replacement

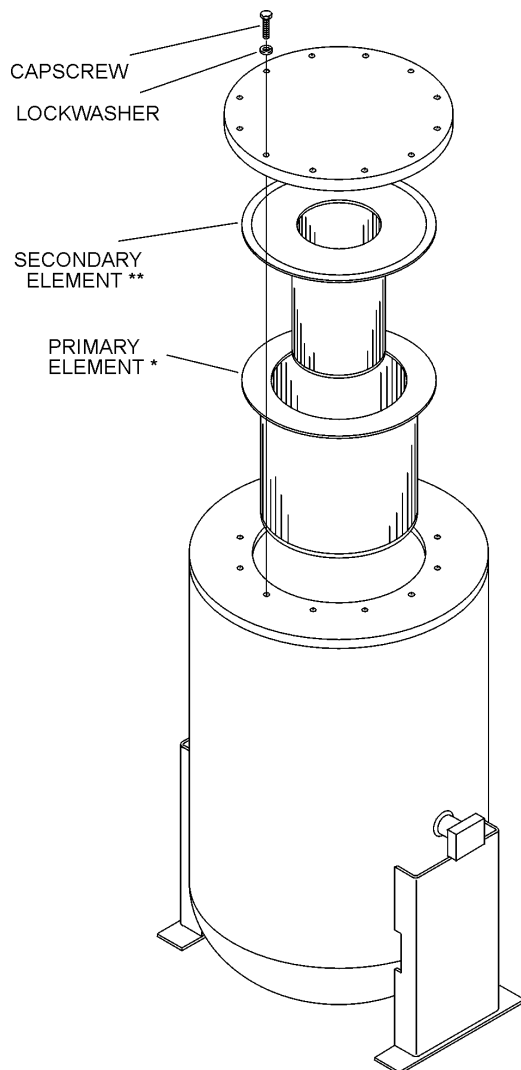

*Primary Replacement Element P/N 250034-122

**Secondary Replacement Element P/N 250034-134

DO NOT “blow” dirt out of the interior of the filter housing. This may introduce dust downstream of the filter. Instead, use a clean damp cloth.

DO NOT oil the element.

ELEMENT INSPECTION

1. Place a bright light inside the element to inspect for damage or leak holes. Concentrated light will shine through the element, revealing any holes.
2. Inspect all gaskets and gasket contact surfaces of the housing. Should faulty gaskets be evident, correct the condition immediately.
3. If the clean element is to be stored for later use, it must be stored in a clean, closed container.
4. After the element has been installed, inspect and

tighten, if necessary, all air inlet connections prior to resuming operation.

PRIMARY ELEMENT REPLACEMENT

1. Place the element in position over secondary element. Replace the sealing washer and wingnut. Tighten the wingnut so as to fully seat the element gasket.
2. Install the cover/element assembly and replace the wingnut.

SEPARATOR ELEMENTS REPLACEMENT

Refer to Figure 7-3. The separator elements must be changed when “Separator Maintenance Required” message is displayed, or once a year whichever occurs first. Follow the procedure explained below for separator element replacement.

PROCEDURE FOR 200-350HP/149-261KW ELEMENT REPLACEMENT

1. Relieve all pressure from the separator and all compressor lines prior to disconnecting any pipes, tubing, etc.
2. Disconnect all piping connected to the separator cover to allow removal (return lines, service lines, etc.).
3. Loosen and remove the twelve (12) 3/4" x 3" hex head capscrews from the cover plate.
4. Lift the cover plate from the separator using a 3/4" jackscrew under the lifting arm post. The lid can be pivoted to the side supported by the lifting arm.
5. Remove the primary and secondary separator elements.
6. Scrape the old gasket material from the cover and flange on the sump being careful not to let the scraps fall in the sump.
7. Inspect the separator tank for rust, dirt, etc.
8. Reinsert the separator elements with gaskets attached into the sump taking care not to dent them against the tank opening. **DO NOT** remove grounding staples. Check between separator element flange and tank for continuity after torquing bolts. **DO NOT** use anti-seize compound on gaskets.
9. Clean the underside of the separator tank cover and remove any rust.
10. Replace the cover plate, washers and 3/4-10 capscrews. Lubricate and Torque to 200 ft.-lbs. (271 Nm).
11. Reconnect all piping making sure return line

Section 7 MAINTENANCE

Figure 7-4 Oil Return/Sight Glass

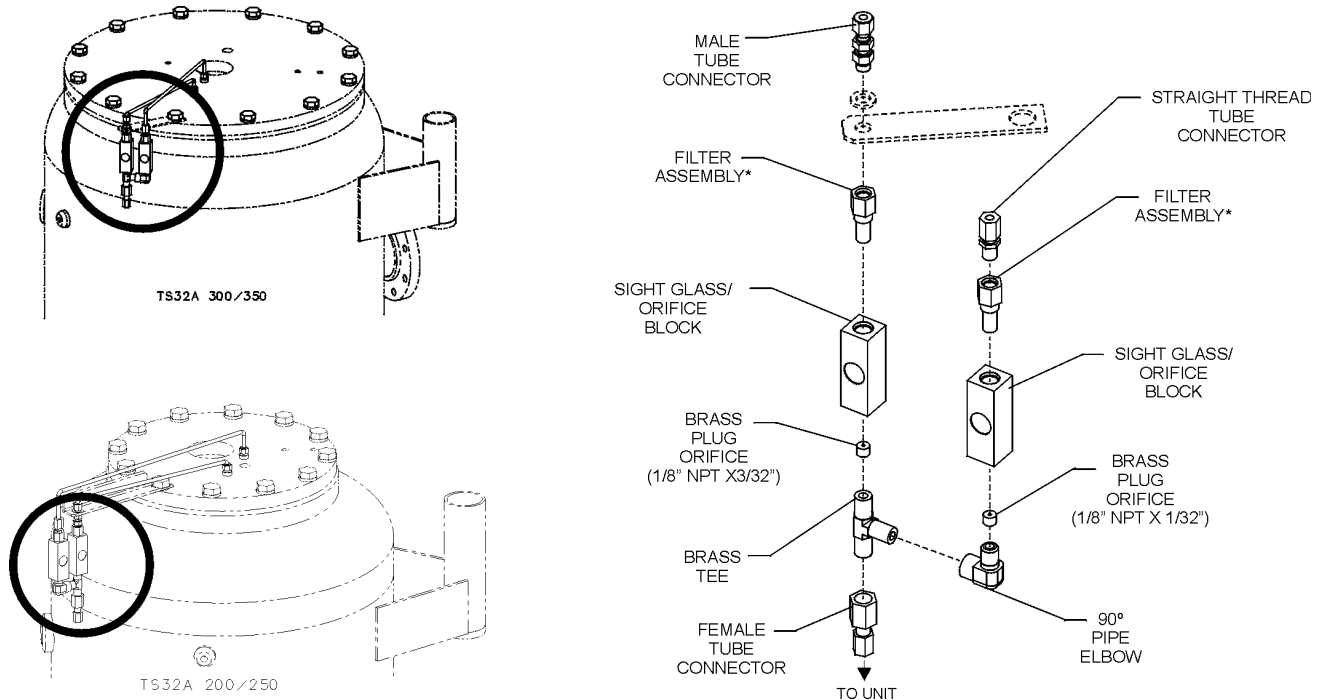

*Replacement Filter Assembly P/N 02250117-782

tubes extend to the bottom or 1/4" (6mm) above the bottom of the separator element. This will assure proper fluid return flow to the compressor.

- Check the return line strainers before restarting the compressor (order replacement kit no. 02250117-782).

OIL RETURN/SIGHT GLASS MAINTENANCE

Refer to Figure 7-4. The oil return/sight glass sub-assembly is attached to the separator tank lid. Oil return/sight glass maintenance should be performed on a routine basis parallel to that of the fluid filter, or as indicated in the Troubleshooting Sections (both Supervisor and Maintenance) of this manual. The maintenance on an oil return/sight glass is mainly concerned with the condition of the filter assembly. Order filter assembly no. 02250117-782, and use the following instructions as a guide.

NOTE

Always performing maintenance on both oil return/sight glasses at the same time.

- Disconnect the tubes at the tops of the sight glass assemblies.
- Unscrew male connector (for left-side glass), or the straight thread tube connector (for right-side glass) from sight glass/orifice blocks.

- Remove used filter assembly, and replace with new assembly.
- Coat/lubricate the O-rings with silicone grease.
- Reattach the connectors to the sight glass/orifice blocks.

DIFFERENTIAL PRESSURE REGULATOR ADJUSTMENT

Refer to Figure 7-5 and 7-6. The differential pressure regulators are adjusted by loosening the jam nut on the end of the cone shaped cover of the pressure regulator. When the jam nut is loose, turn the adjusting screw clockwise to increase or counterclockwise to decrease the setting.

Above 100 psig (6.9 bar), the spiral valve regulator should allow pressure to flow into the chamber of the spiral valve actuator. The spiral valve should start to rotate at this time.

At approximately 108 psig (7.5 bar), the Sullicon regulator should allow pressure to flow into the control chamber of the Sullicon Control. The Sullicon Control level should start to move at this time. Cycle the Control System several times and recheck all pressure settings.

DRIVE COUPLING INSTALLATION AND ALIGNMENT (200-350HP/ 149-261KW)

Refer to Figures 7-7, 7-8 and 7-9. For coupling

Figure 7-5 Pressure Regulator Adjustments

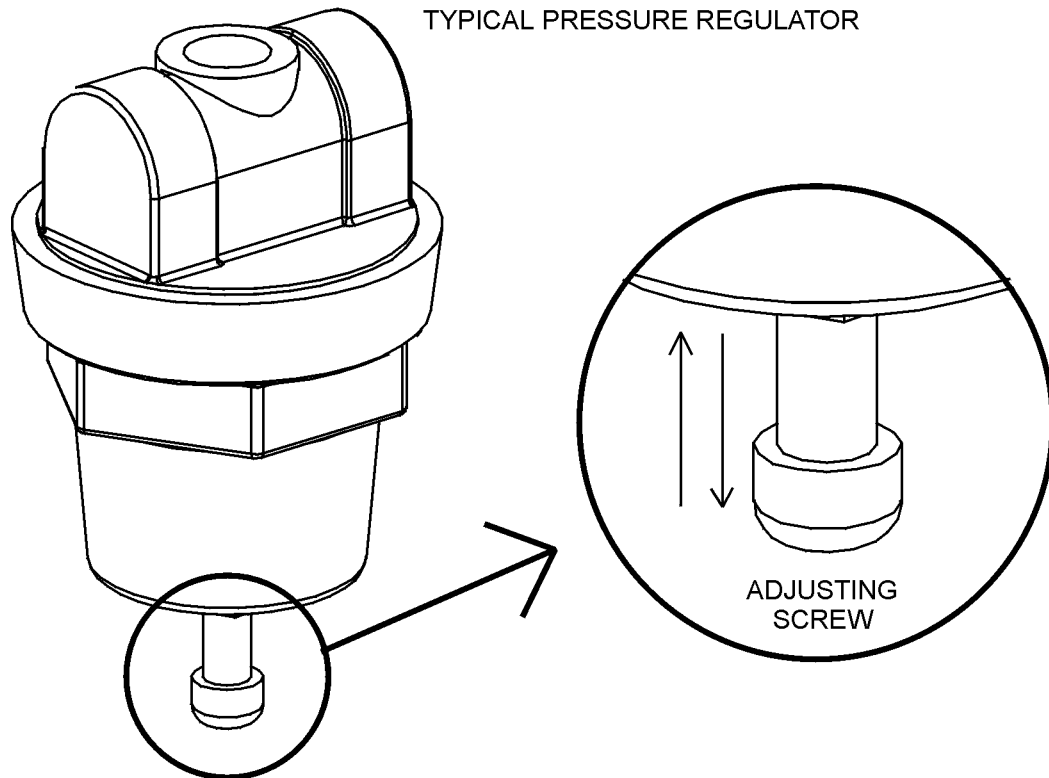

installation and alignment, the tools required are a straight edge, a measuring scale, one set of feeler gauges, a set of standard Allen wrenches and one set of standard socket wrenches.

Figure 7-6 Sullicon Control (P/N 011682-003)

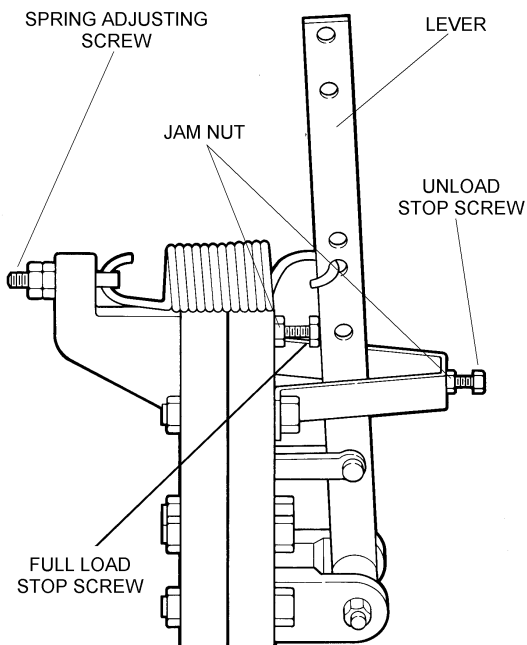

⚠ WARNING

Disconnect all power at source, before attempting maintenance or adjustments.

For installation and alignment of the drive coupling, follow the steps explained below.

STEP 1 MOUNT HUBS - Mount the motor hub and the compressor hub onto respective shaft. Position the hubs to establish the correct gap specified in Table 1. Secure each hub with a setscrew.

STEP 2 OFFSET ALIGNMENT - Clean any oil, grease, dirt or paint from coupling faces and the other surfaces of the drive flanges. Rotate shafts so

**TABLE 1
INSTALLATION DATA (200-350HP/149-261KW)**

Tightening Torque ft.-lbs.-Nm	Coupling Gap inches/cm	Max. Operating Misalignment	
		Parallel Offset inches/cm	Angular inches/cm (I)
200	2.969 + .030 - .000	.010	.010
271Nm	7.5 + .08 - .000	.03	.03

(I) Angular misalignment in inches equals maximum A minus minimum B as shown in Figure 7-8. **DO NOT** exceed values in Table above.

Section 7 MAINTENANCE

Figure 7-7 Drive Coupling (200-300HP/ 150-225KW)

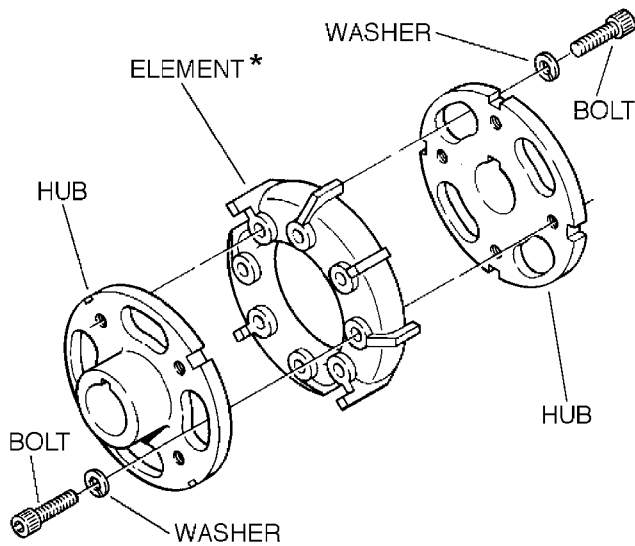

*Replacement Element P/N 046999

that a straight edge will rest squarely (or within the 0.010 inch maximum limit shown in Table 1) on both flanges and at a point 90° away. The vertical offset alignment is adjusted by the addition or removal of motor mounting shims. Loosen the motor mounting bolts and slide the motor sideways to correct the horizontal offset.

STEP 3 COUPLING GAP AND ANGULAR ALIGNMENT - Position the hubs to establish the proper gap and angular alignment as indicated in Table 1. To determine the angular misalignment in inches, measure the maximum space between the hub flanges and the minimum space 180° away, and then subtract. To adjust the horizontal angular misalignment, loosen the motor mounting bolts and adjust the motor position until the angular alignment is within tolerance.

⚠ WARNING

DO NOT upset the offset alignment or hub gap when adjusting motor position.

Figure 7-8 Drive Coupling Alignment

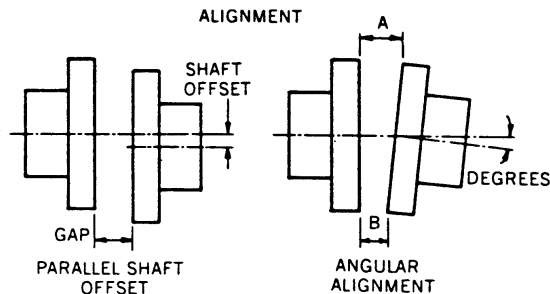

When within the limits specified in Table 1, tighten the motor mounting bolts and recheck the offset and angular alignment. If the vertical angular alignment is not within .010 inch tolerance, shim the front or rear of the motor separately to correct. Recheck the vertical offset.

STEP 4 INSTALL THE FLEXIBLE ELEMENT - Position the motor and compressor keyways 180° apart. Insert the flexible element between the two hubs. The element should be compressed prior to insertion. The element can be compressed by tightening a suitably sized radiator hose clamp around the outer edge of the element as shown in Figure 7-8. Slide the ferry head capscrews with lockwashers

Figure 7-9 Parallel/ Angular Offset Alignment

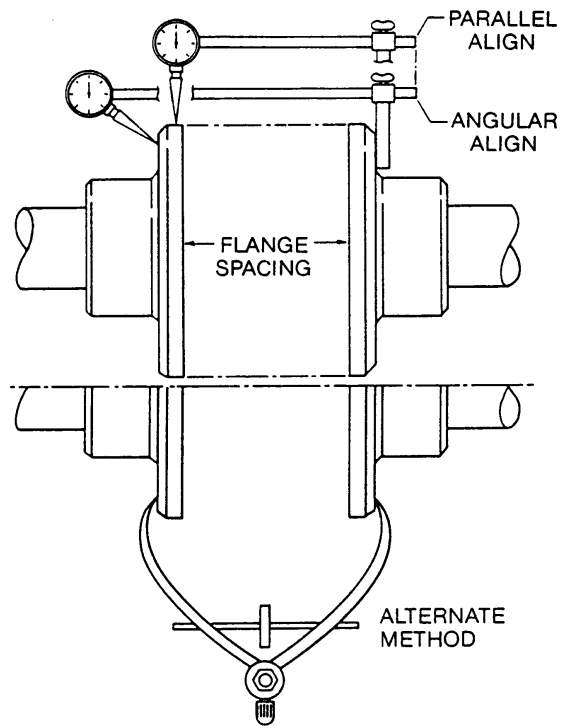

through the holes in the hubs and element. Tighten the capscrews to 200 ft.-lbs. (271 Nm).

NOTE

Capscrews are 3/4-10 x 4" LG ASTM A354 Grade BD yellow zinc di-chromate. DO NOT substitute with any other bolts.

After tightening the capscrews, tighten the shaft setscrews and remove the hose clamp from the flexible element. At this time, the coupling is ready for operation.

Section 7 MAINTENANCE

7.8 TROUBLESHOOTING

The information contained in the Troubleshooting chart is based upon both the actual applied situations and extensive testing at the factory. It contains symptoms and usual causes for the described problems. However **DO NOT** assume that these are the only problems that may occur. All available data concerning the trouble should be systematically analyzed before undertaking any repair or component replacement.

A detailed visual inspection is worth performing for

almost any problems which may prevent unnecessary damage to the compressor. Always remember to:

- a. Check for loose wiring.
- b. Check for damaged piping.
- c. Check for parts damaged by heat or an electrical short circuit, usually apparent by discoloration or a burnt odor.

Should your problem persist after making the recommended check, consult your nearest Sullair representative or the Sullair Corporation.

7.9 TROUBLESHOOTING GUIDE (I)

SYMPTOM	PROBABLE CAUSE	REMEDY
COMPRESSOR WILL NOT START	Main Disconnect Switch Open	Close switch.
	Line Fuse Blown	Replace fuse.
	Control Transformer Fuse Blown	Replace fuse.
	Motor Starter Overloads Tripped	Reset. Should trouble persist, check whether motor starter contacts are functioning properly.
	Low Incoming Line Voltage	Check voltage. Should voltage check low, consult power company.
		Replace Supervisor display module if no display or erratic display.
COMPRESSOR SHUTS DOWN WITH AIR DEMAND PRESENT	Loss of Control Voltage	Check incoming power.
	Low Incoming Voltage	Check control fuses and wiring. Consult power company. The Sullair Supervisor will provide indication of most maintenance problems if control power has not been lost. Shutdowns will occur upon a faulty condition or a bad sender condition.
	Excessive Operating Pressure	Check maximum P2 pressure setting. HIGH PRESS P1 display; Max P1 pressure may be set too low. Consult factory for recalibration. Defective solenoid valve; solenoid valve should cause Sullicon Control lever to move to unload stop when the unload pressure setting P2A is exceeded. Repair if defective. Defective blowdown valve; blowdown valve should exhaust sump pressure to 30 psig (2.1 bar) for integrated coolers; 50 psig (3.4 bar) for remote coolers when maximum operating pressure is reached. Repair if defective. Open or shorted P1, P2, P3 or P4 sender message; replace sender indicated. Operating lever of inlet butterfly valve is loose on valve shaft. Reposition the valve plate and tighten lever set screw.

(I) Consult [Section 5.13](#) for additional Supervisor aids to troubleshooting.

Section 7 MAINTENANCE

7.9 TROUBLESHOOTING GUIDE (CONTINUED)

SYMPTOM	PROBABLE CAUSE	REMEDY
COMPRESSOR SHUTS DOWN WITH AIR DEMAND PRESENT (CONTINUED)	HIGH TEMP T1 or T3 Message Displayed	Cooling water temperature too high; increase water flow (water-cooled only).
		Cooling water flow insufficient; check water lines, valves (water-cooled only) and available water pressure differential.
		Cooler plugged; clean tubes. If plugging persists, install water conditioner or water filter(water-cooled only).
		Cooling air flow restricted; clean cooler and check for proper ventilation.
		Ambient temperature is too high; provide sufficient ventilation.
		Cooling air ductwork, if installed, may restrict air flow. High static fan must be specified with customer-supplied ductwork, and ductwork must be sized to minimize flow restriction.
		Low fluid level; add fluid.
		Clogged filter; change the fluid filter element as indicated by Supervisor control.
		Thermal valve not functioning properly; replace element (air-cooled only).
		Optional Water flow regulating valve not functioning properly; change (water-cooled only).
COMPRESSOR WILL NOT BUILD UP FULL DISCHARGE PRESSURE	Air Demand is Too Great	Open or shorted T1 or T2 sender; check for a short or open circuit to probe and correct wiring.
		Excessive pressure drop in supply and return lines of remote air-cooled cooling package. Consult paragraph 4.6 of this manual.
		Check fluid level.
		Check for clogged fluid filter.
		Check the cooling fan motor or water flow system.
LINE PRESSURE RISES ABOVE UNLOAD P2 PRESSURE SETTING ON THE SUPERVISOR	Leak in Control System Causing Loss of Pressure Signals	Low Fluid Pressure (LOW PRESSURE P3 display)
		Low Water Pressure (FAN OL/LOW WATER display)
		Check service lines for leaks or open valves.
		Check for filter maintenance message on supervisor panel and change or clean element if required.
		Adjust regulator according to control adjustment instructions in the Maintenance Section.
COMPRESSOR WILL NOT BUILD UP FULL DISCHARGE PRESSURE	Dirty Air Filter	Defective Pressure Regulator
		Pressure Regulator Out of Adjustment
		Check diaphragm and replace if necessary (kit available).
COMPRESSOR WILL NOT BUILD UP FULL DISCHARGE PRESSURE	Broken Sullicon Spring	Replace.
		Check for leaks.

Section 7 MAINTENANCE

7.9 TROUBLESHOOTING GUIDE (CONTINUED)

SYMPTOM	PROBABLE CAUSE	REMEDY
LINE PRESSURE RISES ABOVE UNLOAD P2 PRESSURE SETTING ON THE SUPERVISOR (CONT.)	Defective Solenoid Valve	Check that Sullicon Control lever is moved to unload stop when Supervisor is in NO LOAD mode. Repair or replace if necessary (kit available).
	Defective Blowdown Valve	Check that sump pressure is exhausted to the atmosphere when in the OFF LOAD mode. Repair or replace if necessary (kit available).
	Ruptured Sullicon Control Diaphragm	Replace.
	Plugged Control Line Filter	Clean or repair if necessary.
EXCESSIVE FLUID CONSUMPTION	Clogged Return Line Strainer or Orifice	Clean strainer (screen with o-ring replacement kit available) Clean orifice.
	Separator Element Damaged or Not Functioning Properly	Check Separator Differential (plugged) dP1. Change Separator
	Leak in the Lubrication System	Check all pipes, connections and components.
	Excess Fluid Foaming	Drain and change.
	Fluid Level Too High	Drain excess fluid.
PRESSURE RELIEF VALVE OPENS REPEATEDLY	Defective Pressure Relief Valve	Replace pressure relief valve.
LIQUID WATER IN COMPRESSED AIR SERVICE LINE	Water Vapor Condensation From Cooling and Compression Occurs Naturally	Remove the water vapor from compressed air prior to distribution through the air system. Check operation of aftercooler and moisture separator. Install a compressed air dryer sized for the flow and dryness level required. (Note: Filters may also be required to remove particulates, liquid oil aerosols or for oil vapor removal. Change cartridges as recommended by the filter manufacturer.) Check all drain traps routinely to insure their proper operation. Maintain them regularly.

NOTES

Section 8

ILLUSTRATIONS AND PARTS LIST

8.1 PROCEDURE FOR ORDERING PARTS

Parts should be ordered from the nearest Sullair Representative or the Representative from whom the compressor was purchased. If for any reason parts cannot be obtained in this manner, contact the factory directly at the address or phone numbers listed below.

When ordering parts always indicate the Serial Number of the compressor. This can be obtained from the Bill of Lading for the compressor or from the Serial Number Plate located on the compressor. For compressor unit parts only, order parts by the unit serial number plate located on the compressor unit.

For ordering parts other than those pertaining to the compressor unit, use serial number located on nameplate mounted on control panel.

SULLAIR ASIA, LTD.
Sullair Road, No. 1
Chiwan, Shekou
Shenzhen, Guangdong PRV.
PRC POST CODE 518068
Telephone: 755-6851686
Fax: 755-6853473

SULLAIR EUROPE, S.A.
Zone Des Granges BP 82
42602 Montbrison Cedex, France
Telephone: 33-477968470
Fax: 33-477968499

SULLAIR CORPORATION
3700 East Michigan Boulevard
Michigan City, Indiana 46360 U.S.A.
Telephone: 1-800-SULLAIR (U.S.A. Only)
or 1-219-879-5451
Fax: (219) 874-1273
Fax: (219) 874-1835 (Parts)
Fax: (219) 874-1205 (Service)

8.2 RECOMMENDED SPARE PARTS LIST - 200 and 250HP/ 149 and 186KW

DESCRIPTION	KIT NUMBER	QUANTITY
repair kit for fluid stop valve 02250113-668	02250116-697	1
repair kit for thermal valve (175°) 02250127-119	02250105-553	1
repair kit for thermal valve (195°) 02250127-962 (I)	02250112-709	1
element for separator with gaskets (primary)	250034-122	1
element for separator with gaskets (secondary)	250034-134	1
repair kit for regulator valve 406929	041742	1
repair kit for blowdown valve 044912	046782	1
repair kit for Sullicon Control 011682-003	250020-353	1
repair kit for control line filter 02250112-032	02250112-031	1
replacement kit for fluid return strainer	02250117-782	1
element for 18" diameter air filter 250006-718 (primary)	250007-838	1
element for 18" diameter air filter 250006-718 (secondary)	250007-839	1
repair kit for water separator 02250111-105	Consult Factory	1

(Continued on [page 54](#))

(I) For 24KT water-cooled, and \geq 150 psig compressors.

PLEASE NOTE: WHEN ORDERING PARTS, INDICATE SERIAL NUMBER OF COMPRESSOR

Section 8

ILLUSTRATIONS AND PARTS LIST

8.2 RECOMMENDED SPARE PARTS LIST - 200 and 250HP/ 149 and 186KW (CONTINUED)

DESCRIPTION	KIT NUMBER	QUANTITY
replacement kit for fluid filter 02250121-658	02250121-657	1
repair kit for solenoid valve 02250125-657	02250125-829 (valve)	1
replacement coil for solenoid valve 02250125-657	02250125-861 (coil)	1
repair kit for solenoid valve 02250125-679	02250125-824	1
replacement coil for solenoid valve 02250125-679	02250125-861 (coil)	1
repair kit for regulator valve 408275	250028-693	1
repair kit for minimum pressure valve 250033-821	250018-262	1
repair kit for shaft seal	067329-001	1
element for drive coupling	046999	1
diaphragm repair kit for spiral valve air cylinder 250016-183	608311-001	1
repair kit for SCD zero loss drain 02250130-866	02250131-044	1
o-ring for 2 1/2 -12 SAE tube fittings	250042-649	-
o-ring for 1 7/8 -12 SAE tube fittings	250042-648	-
compressor Sullube fluid (5 gallons)	250022-669	-
compressor 24KT fluid (5 gallons)	02250051-153	-
compressor CP-4600-32-F fluid (5 gallons)	250029-008	-

PLEASE NOTE: WHEN ORDERING PARTS, INDICATE SERIAL NUMBER OF COMPRESSOR

Section 8

ILLUSTRATIONS AND PARTS LIST

8.3 RECOMMENDED SPARE PARTS LIST - 300 and 350HP/ 224 and 261KW

DESCRIPTION	QUANTITY	KIT NUMBER
repair kit for fluid stop valve 02250122-004	001684	1
repair kit for thermal valve (170°) 02250120-955	02250120-957	1
repair kit for thermal valve (195°) 02250127-962 (I)	02250127-963	1
element for separator with gaskets 250034-123 (primary)	250034-124	1
element for separator with gaskets 250034-129 (secondary)	250034-130	1
repair kit for regulator valve 406929	041742	1
repair kit for blowdown valve 409783	001667	1
repair kit for Sullicon Control 011682-003	250020-353	1
repair kit for control line filter 02250112-032	02250112-031	1
repair kit for fluid return strainer	02250117-782	1
element for 18" diameter air filter 250006-718 (primary)	250007-838	1
element for 18" diameter air filter 250006-718 (secondary)	250007-839	1
replacement kit for fluid filter 02250128-717	02250121-657	1
repair kit for solenoid valve 02250125-657	02250125-829 (valve)	1
replacement coil for solenoid valve 02250125-657	02250125-861 (coil)	1
repair kit for solenoid valve 02250125-679	02250125-824	1
replacement coil for solenoid valve 02250125-679	02250125-861 (coil)	1
repair kit for regulator valve 408275	250028-693	1
repair kit for minimum pressure valve 250033-821	250018-262	1
repair kit for shaft seal	067329-001	1
element for drive coupling	046999	1
diaphragm repair kit for spiral valve air cylinder 250016-183	608311-001	1
repair kit for SCD zero loss drain 02250130-866	02250131-044	1
o-ring for 2 1/2 -12 SAE tube fittings	250042-649	1

(I) For 24KT water-cooled, and \geq 150 psig compressors.

PLEASE NOTE: WHEN ORDERING PARTS, INDICATE SERIAL NUMBER OF COMPRESSOR

Section 8 ILLUSTRATIONS AND PARTS LIST

8.4 MOTOR, COMPRESSOR, FRAME AND PARTS- GEAR DRIVE

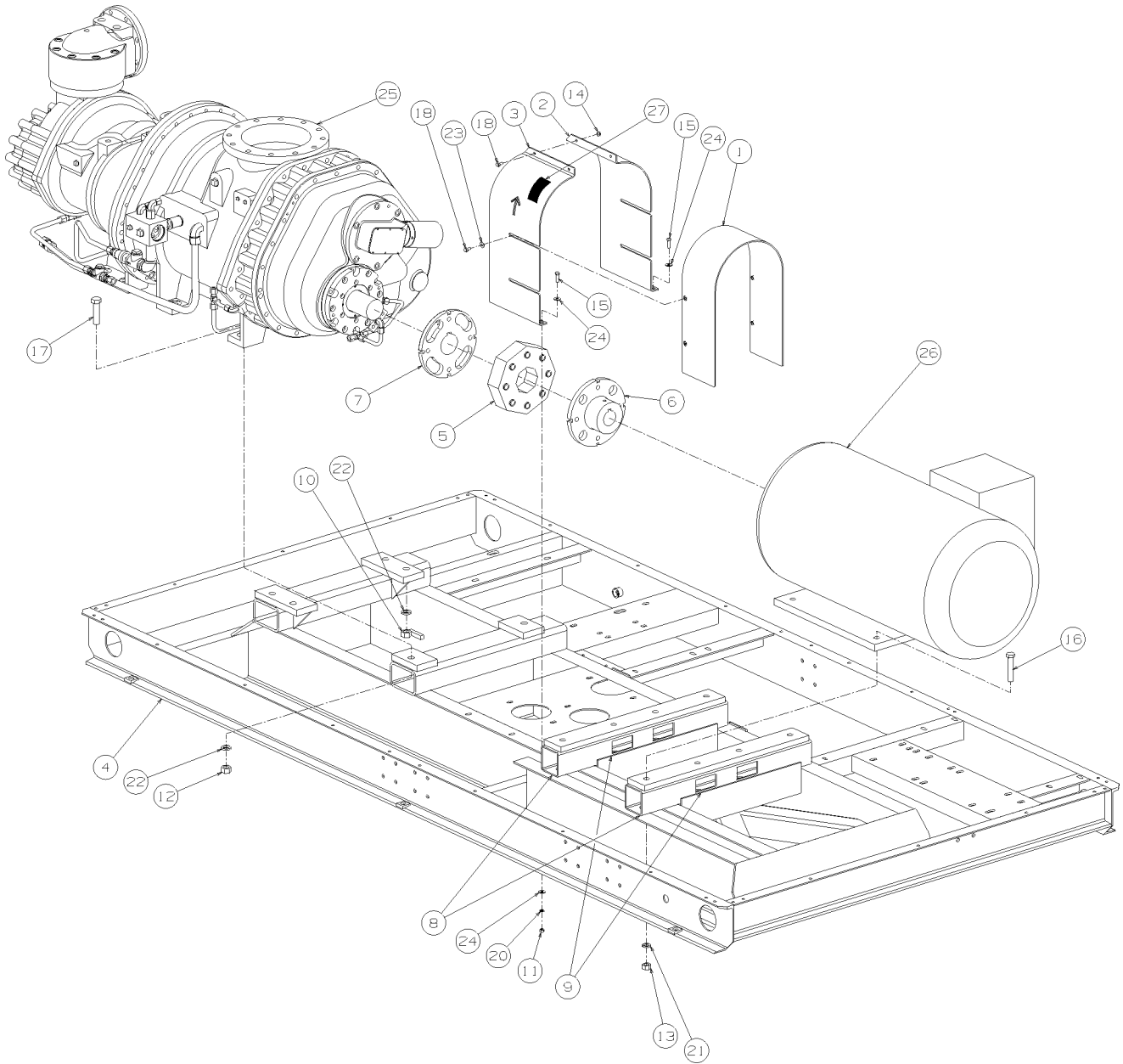

Section 8

ILLUSTRATIONS AND PARTS LIST

8.4 MOTOR, COMPRESSOR, FRAME AND PARTS- GEAR DRIVE

<i>key number</i>	<i>description</i>	<i>part number</i>	<i>quantity</i>
1	guard, coupling cntr ts32-200/300 gd/dd adj.	02250113-548	1
2	guard, coupling l.h. ts32-200/300 gd adj.	02250113-565	1
3	guard, coupling r.h. ts32-200/300h gd adj.	02250113-566	1
4	frame, main ts32-300/350	02250122-221	1
5	element,dr couplg-saga 34 (I)	046999	1
6	hub, coupling saga 34a 2-3/8 x 5/8	250004-635	1
7	hub, coupling saga 34a 3-1/4 x 3/4	250005-091	1
8	motor support, toshiba 447tss	250007-215	2
9	bar,mtr supt 5 x .25 x 23.25"	250007-218	2
10	nut,assy compr mtg 32/25	250024-587	3
11	nut,hex unfin 3/8-16	824206-337	4
12	nut,hex unfin 7/8-9	824214-776	3
13	nut,hex pltd 3/4-10	825212-665	4
14	nut,hex f pltd 5/16-18	825305-283	3
15	capscr, hex gr5 3/8-16 x 1 1/4	829106-125	4
16	capscr, hex gr5 3/4-10 x 4	829112-400	4
17	capscr, hex gr5 7/8-9 x 3 1/2	829114-350	6
18	screw, hex ser washer 5/16-18 x 3/4	829705-075	6
19	screw, hex ser washer 5/16-18 x 1	829705-100	1
20	washer, spr lock 3/8	837506-094	4
21	washer, spr lock reg pltd 3/4	837812-188	4
22	washer, spr lock reg pltd 7/8	837814-219	6
23	washer, pl-b reg pltd 5/16	838205-071	5
24	washer, pl-b reg pltd 3/8	838206-071	8
25	compressor & part, ddr321170a (II)	-	1
26	motor, main (III)	-	1
27	sign, warning-sever-fan	049855	1

(I) For maintenance on drive coupling element, order drive coupling replacement no. 046999.

(II) There is an exchange program whereby a remanufactured compressor unit can be obtained from Sullair distributors or the factory at less cost than the owner could repair the unit. For information regarding the unit exchange program, contact your nearest Sullair representative or the Sullair Corporation.

The shaft seal is not considered part of the compressor unit in regard to the two year warranty. The normal Sullair parts warranty applies. For shaft seal repairs order repair kit no. 067329- 001.

(III) Motor may vary. Consult factory with machine serial number.

PLEASE NOTE: WHEN ORDERING PARTS, INDICATE SERIAL NUMBER OF COMPRESSOR

Section 8 ILLUSTRATIONS AND PARTS LIST

8.5 MOTOR, COMPRESSOR, FRAME AND PARTS- DIRECT DRIVE

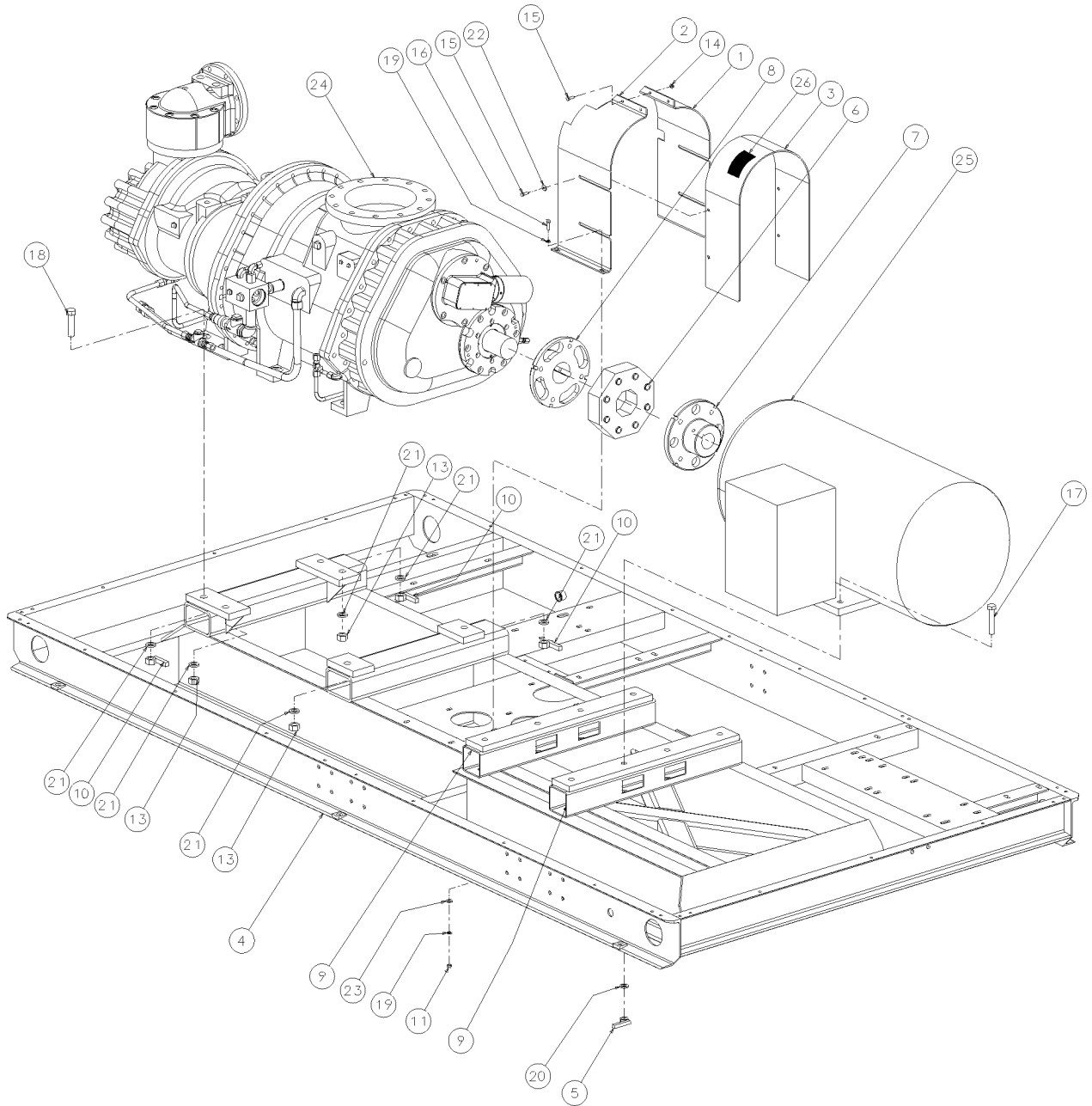

02250131-577R01

Section 8

ILLUSTRATIONS AND PARTS LIST

8.5 MOTOR, COMPRESSOR, FRAME AND PARTS- DIRECT DRIVE

<i>key number</i>	<i>description</i>	<i>part number</i>	<i>quantity</i>
1	gd.cplg lh ts32 200-300h dd	02250113-546	1
2	guard, coupling rh ts32-200-300h dd	02250113-547	1
3	guard, coupling cntr ts32-200/300 gd/dd adj.	02250113-548	1
4	frame, main ts32-300/350	02250122-221	1
5	nut,assy compr mtg 32/25	02250135-358	4
6	element,dr couplg-saga 34 (I)	046999	1
7	hub, coupling saga 34a 2-3/8 x 5/8	250004-635	1
8	hub, coupling saga 34a 3-1/4 x 3/4	250005-091	1
9	motor support, toshiba 447tss	250007-215	2
10	nut,assy compr mtg 32/25	250024-587	3
11	nut,hex pltd 3/8-16	825206-337	4
12	nut,hex pltd 3/4-10	825212-665	7
13	nut,hex pltd 7/8-9	825214-776	3
14	nut,hex f pltd 5/16-18	825305-283	2
15	capscr, hex gr5 5/16-18 x 1	829105-100	6
16	capscr, hex gr5 3/8-16 x 1 1/4	829106-125	4
17	capscr, hex gr5 3/4-10 x 4	829112-400	4
18	capscr, hex gr5 7/8-9 x 3 1/2	829114-350	6
19	washer, spr lock reg pltd 3/8	837806-094	8
20	washer, spr lock reg pltd 3/4	837812-188	4
21	washer, spr lock reg pltd 7/8	837814-219	6
22	washer, pl-b reg pltd 5/16	838205-071	4
23	washer, pl-b reg pltd 3/8	838206-071	4
24	compressor & part,ddr321170a10me57vcb (II)	-	1
25	motor, main (III)	-	1
26	sign, warning-sever-fan	049855	1

(I) For maintenance on drive coupling element, order drive coupling replacement no. 046999.

(II) There is an exchange program whereby a remanufactured compressor unit can be obtained from Sullair distributors or the factory at less cost than the owner could repair the unit. For information regarding the unit exchange program, contact your nearest Sullair representative or the Sullair Corporation.

The shaft seal is not considered part of the compressor unit in regard to the two year warranty. The normal Sullair parts warranty applies. For shaft seal repairs order repair kit no. 067329-001.

(III) Motor may vary. Consult factory with machine serial number.

PLEASE NOTE: WHEN ORDERING PARTS, INDICATE SERIAL NUMBER OF COMPRESSOR

Section 8 ILLUSTRATIONS AND PARTS LIST

8.6 AIR INLET SYSTEM

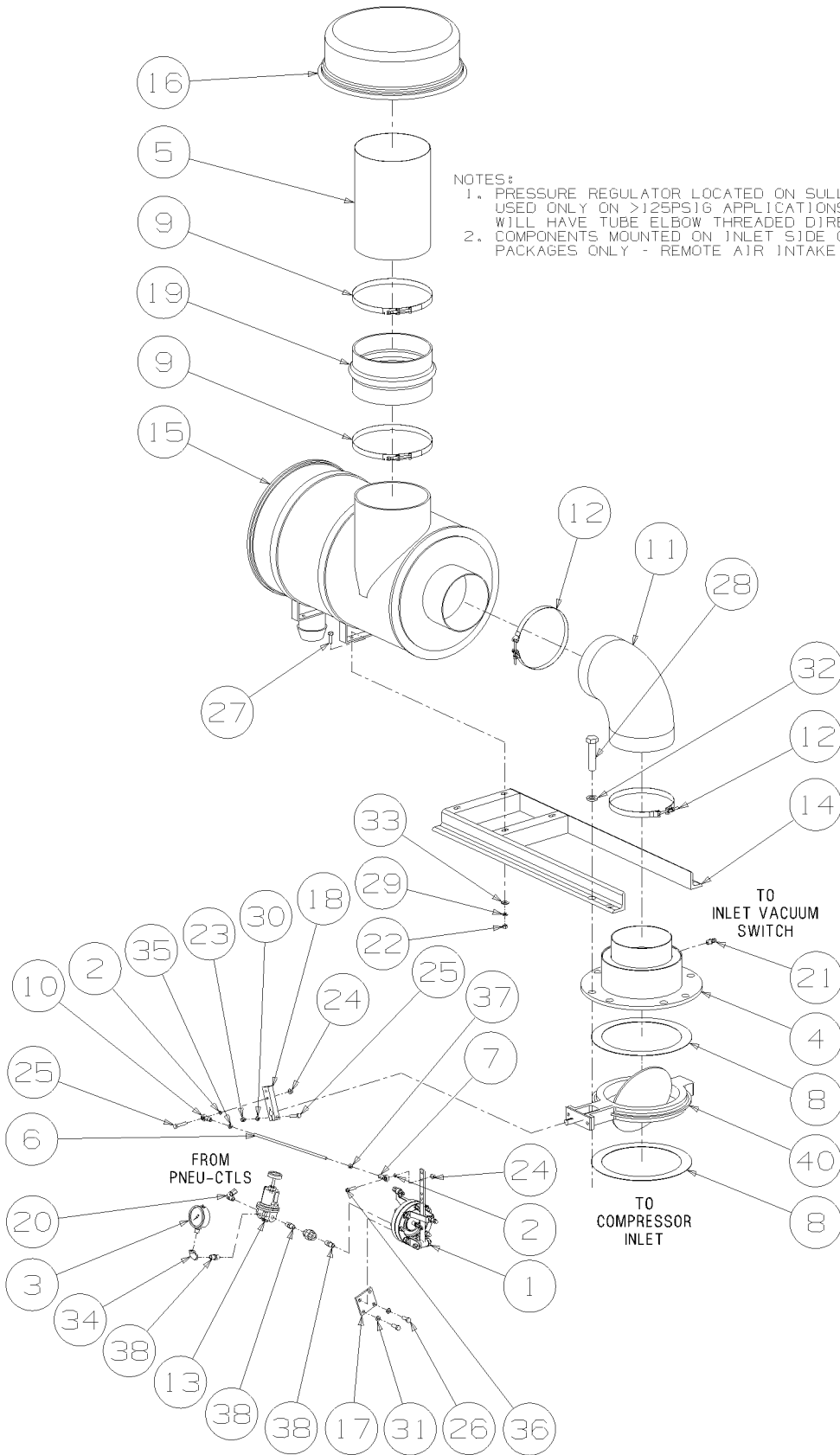

NOTES:
 1. PRESSURE REGULATOR LOCATED ON SULLICON ASSEMBLY USED ONLY ON >125PSIG APPLICATIONS. LOWER PRESSURES WILL HAVE TUBE ELBOW THREADED DIRECTLY INTO ASSEMBLY.
 2. COMPONENTS MOUNTED ON INLET SIDE OF FILTER FOR CANOPY PACKAGES ONLY - REMOTE AIR INTAKE.

Section 8 ILLUSTRATIONS AND PARTS LIST

8.6 AIR INLET SYSTEM

<i>key number</i>	<i>description</i>	<i>part number</i>	<i>quantity</i>
1	control, Sullicon less brkt (I)	011682-003	1
2	washer, sprlock hi clr 5/16"	02250112-561	2
3	gage, air press 2 1/2" 0-200 psi (II)	02250117-009	1
4	adapter, compressor inlet 10" to 8" w/1"npt p	02250130-375	1
5	tube, 10"od x .063"alum x 14"lg	029846	1
6	rod,link compressor	029910	1
7	rod end, spherical rh 5/16	040136	1
8	gasket, .06 x 10.5id x 13.25od	041079	2
9	clamp, hose t-bolt 10"	041902	2
10	rod end, speical lh 5/16	042004	1
11	elbow, air inlet 90 rubber	043406	1
12	clamp, hose 8"	043598	2
13	regulator,press-1/4npt 2-150# (II)	046556	1
14	support,18" dia air fltr	250003-374	1
15	filter, air 18" dia. (III)	250006-718	1
16	cap,air inlet 10"	250007-712	1
17	bracket, ctl mtg 32/25	250014-397	1
18	lever, inl vlv(3/4"shft)adj	250019-036	1
19	hose, hump 10" id	250019-721	1
20	elbow, tube 90 deg m 1/4 x 1/4	810504-025	1
21	connector, tube-m 1/4 x 1/4	813604-250	1
22	nut,hex unfin 3/8-16	824206-337	4
23	nut,hex pltd 5/16-18	825205-273	1
24	nut,hex f pltd 5/16-18	825305-283	2
25	capscr, hex gr5 5/16-18 x 1 3/4	828605-175	2
26	capscr, hex gr5 3/8-16 x 1	829106-100	2

(Continued on [page 63](#))

(I) For details of the Sullicon Control, consult [Section 8.18](#), Sullicon Control.

(II) This part is used only on machines with pressures higher than 125 psig/ 8.6 bar. Lower pressures will not have tube elbow threaded directly into assembly.

(III) For maintenance on air filter no. 250006-718, order primary replacement element no. 250007-838, and secondary replacement element no. 250007-839.

PLEASE NOTE: WHEN ORDERING PARTS, INDICATE SERIAL NUMBER OF COMPRESSOR

Section 8 ILLUSTRATIONS AND PARTS LIST

8.6 AIR INLET SYSTEM

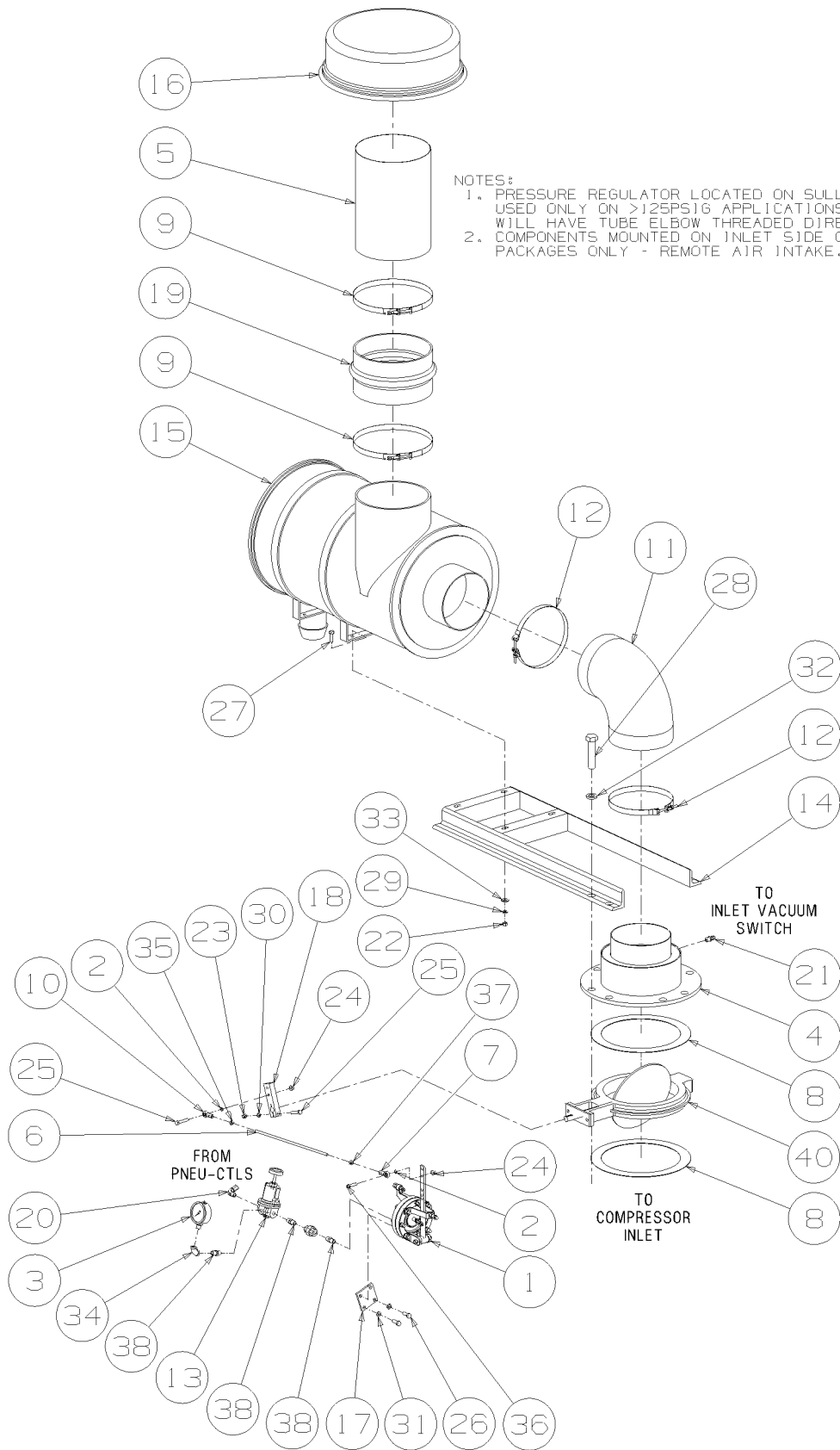

NOTES:
 1. PRESSURE REGULATOR LOCATED ON SULLICON ASSEMBLY USED ONLY ON >125PSIG APPLICATIONS. LOWER PRESSURES WILL HAVE TUBE ELBOW THREADED DIRECTLY INTO ASSEMBLY.
 2. COMPONENTS MOUNTED ON INLET SIDE OF FILTER FOR CANOPY PACKAGES ONLY - REMOVE AIR INTAKE.

Section 8

ILLUSTRATIONS AND PARTS LIST

8.6 AIR INLET SYSTEM (CONTINUED)

<i>key number</i>	<i>description</i>	<i>part number</i>	<i>quantity</i>
27	capscr, hex gr5 3/8-16 x 1 1/4	829106-125	4
28	capscr, hex gr5 7/8-9 x 4	829114-400	8
29	washer, spr lock 3/8	837506-094	4
30	washer, spr lock reg pltd 5/16	837805-078	1
31	washer, spr lock reg pltd 3/8	837806-094	2
32	washer, spr lock reg pltd 7/8	837814-219	8
33	washer, pl-b reg pltd 3/8	838206-071	4
34	elbow, pipe 90 deg plt 1/4" (II)	866215-010	1
35	nut, hex jam lh pltd 5/16-24	866605-195	1
36	capscrew, ferry head hd pltd 5/16-18 x 1 1/4	867305-125	1
37	nut, hex jam rh pltd 5/16-24	868205-195	1
38	nipple,pipe-hx pltd 1/4 x 1/4 (II)	868504-025	3
39	union,pipe-brs seat 1/4 gal 300#	873530-010	1
40	valve, butterfly 10" (IV)	-	1

(II) This part is used only on machines with pressures higher than 125 psig/ 8.6 bar. Lower pressures will not have tube elbow threaded directly into assembly.

(IV) Butterfly valve may vary. Consult factory with machine serial number.

PLEASE NOTE: WHEN ORDERING PARTS, INDICATE SERIAL NUMBER OF COMPRESSOR

Section 8 ILLUSTRATIONS AND PARTS LIST

8.7 FLUID COOLING SYSTEM- AIR-COOLED 200-250HP/ 149-186KW

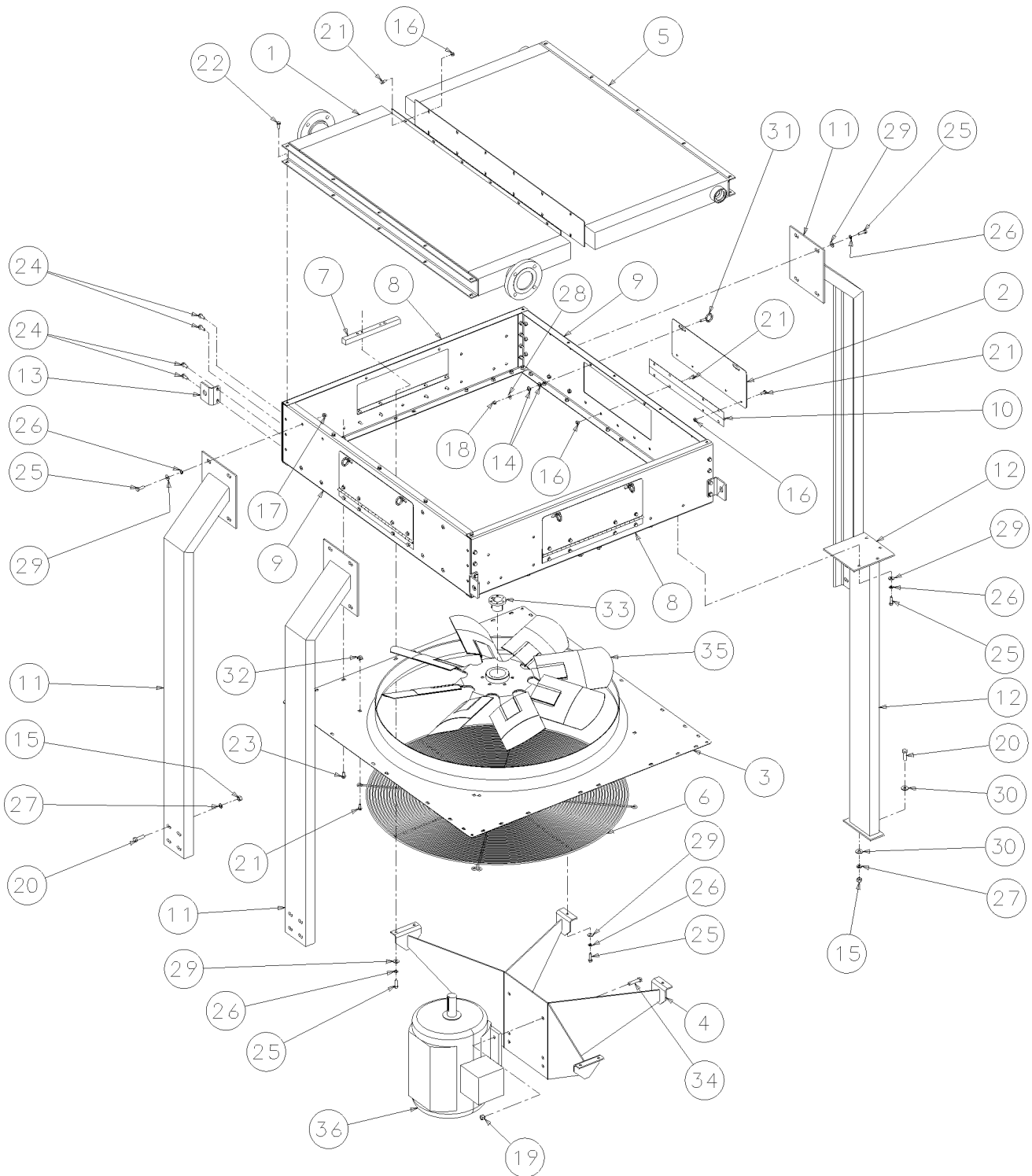

Section 8

ILLUSTRATIONS AND PARTS LIST

8.7 FLUID COOLING SYSTEM- AIR-COOLED 200-250HP/ 149-186KW

<i>key number</i>	<i>description</i>	<i>part number</i>	<i>quantity</i>
1	cooler, air after 200/250hp 200psi	02250121-098	1
2	plate, clean out cover	02250121-123	4
3	panel, venturi 42"fan ts20-250hpac	02250122-381	1
4	support, fan motor ts20-250hpacac (256t m	02250122-428	1
5	heat exchanger,oil(ac)200/250hp 200psi	02250122-858	1
6	guard, fan 42" ts20-150/250hpacac	02250123-366	1
7	bar,back-up horizontal clr pk	02250123-797	2
8	adapter, venturi panel 200/250hpac part	02250123-920	2
9	adapter, venturi panel 200/250hpac part	02250124-924	2
10	hinge, door	02250125-402	4
11	support,cooler ts32a-200/250 intac	02250126-432	3
12	support,cooler ts32a-200/250 intac spcl	02250126-433	1
13	lug,lifting clr pk - 90deg bend	02250132-040	4
14	grommet,rubber	040125	16
15	nut,hex pltd 1/2-13	825208-448	14
16	nut,hex f pltd 5/16-18	825305-283	44
17	nut,hex f pltd 3/8-16	825306-347	12
18	nut,hex locking 5/16-18	825505-166	8
19	nut,hex locking 1/2-13	825508-262	4
20	capscr, hex gr5 1/2-13 x 1 3/4	829108-175	14
21	screw, hex ser washer 5/16-18 x 3/4	829705-075	50
22	screw, hex ser washer 5/16-18 x 1	829705-100	10
23	screw, hex ser washer 3/8-16 x 3/4	829706-075	4
24	screw, hex ser washer 3/8-16 x 1	829706-100	16
25	screw, hex ser washer 3/8-16 x 1 1/4	829706-125	22
26	washer, spr lock reg pltd 3/8	837806-094	22
27	washer, spr lock reg pltd 1/2	837808-125	14
28	washer, pl-b reg pltd 5/16	838205-071	8
29	washer, pl-b reg pltd 3/8	838206-071	22
30	washer, pl-b reg pltd 1/2	838208-112	4
31	eyebolt,5/16-18 x 1 1/8" pltd	839105-112	8
32	nut,retainer 5/16-18 .092	861405-092	6

(Continued on [page 67](#))

PLEASE NOTE: WHEN ORDERING PARTS, INDICATE SERIAL NUMBER OF COMPRESSOR

Section 8 ILLUSTRATIONS AND PARTS LIST

8.7 FLUID COOLING SYSTEM- AIR-COOLED 200-250HP/ 149-186KW

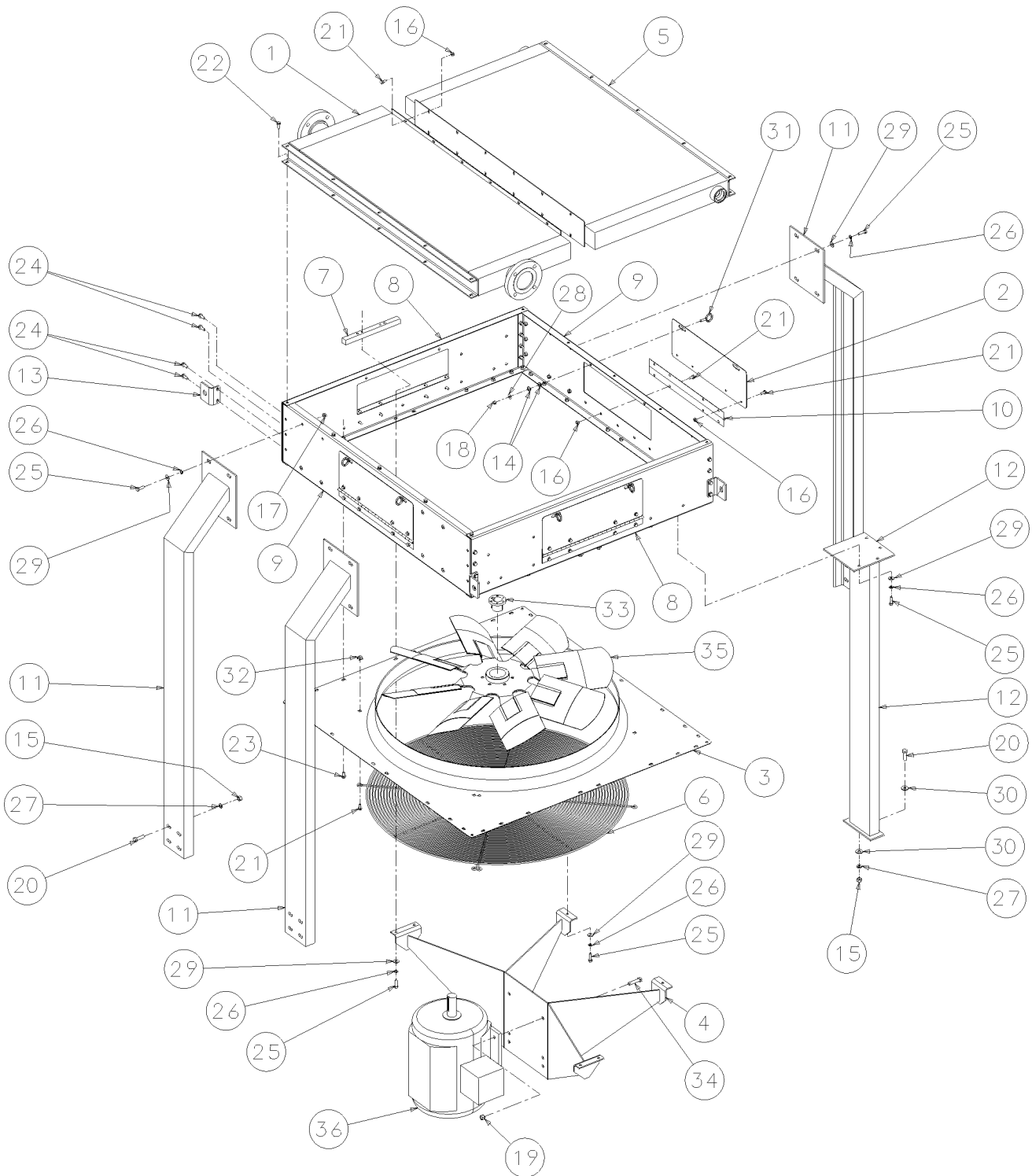

Section 8

ILLUSTRATIONS AND PARTS LIST

8.7 FLUID COOLING SYSTEM- AIR-COOLED 200-250HP/ 149-186KW (CONTINUED)

<i>key number</i>	<i>description</i>	<i>part number</i>	<i>quantity</i>
33	bushing (I)	-	1
34	screw, hex ser washer 1/2-13 x various (I)	-	4
35	fan (I)	-	1
36	motor (I)	-	1

(I) This item may vary with machine. Consult factory with machine serial number.

PLEASE NOTE: WHEN ORDERING PARTS, INDICATE SERIAL NUMBER OF COMPRESSOR

Section 8

ILLUSTRATIONS AND PARTS LIST

8.8 FLUID COOLING SYSTEM- AIR-COOLED 300-350HP/ 224-261KW

<i>key number</i>	<i>description</i>	<i>part number</i>	<i>quantity</i>
1	panel, adapter 400hp clr pk	02250121-117	2
2	panel, adapter 400hp clr pk w/clean	02250121-118	2
3	saddle, motor supt 300/400hp clr pk	02250121-119	1
4	support, mtr 300/400hp clr pk	02250121-120	1
5	plate, clean out cover	02250121-123	4
6	panel, venturi 48" ts32-300-450	02250121-343	1
7	cooler, oil 300/350 hp	02250122-218	1
8	cooler, air aft 300/350 hp	02250122-219	1
9	bar,back-up horizontal clr pk	02250123-797	2
10	support, cooler ts32a-300/350 intac mtrside	02250123-834	2
11	support, cooler ts32a-300/350 intac strside	02250123-835	2
12	hinge, door	02250125-402	4
13	lug,lifting clr pk - 90deg bend	02250132-040	4
14	grommet,rubber	040125	14
15	guard, fan (1600q)	241347	2
16	nut,hex pltd 1/2-13	825208-448	15
17	nut,hex f pltd 5/16-18	825305-283	20
18	nut,hex locking 5/16-18	825505-166	8
19	capscr, hex gr5 3/8-16 x 1 1/4	829106-125	14
20	capscr, hex gr5 1/2-13 x 1 3/4	829108-175	12
21	screw, hex ser washer 5/16-18 x 3/4	829705-075	32
22	screw, hex ser washer 5/16-18 x 1	829705-100	12
23	screw, hex ser washer 3/8-16 x 3/4	829706-075	6
24	screw, hex ser washer 3/8-16 x 1	829706-100	16
25	washer, spr lock reg pltd 3/8	837806-094	9
26	washer, spr lock reg pltd 1/2	837808-125	12
27	washer, pl-b reg pltd 5/16	838205-071	8
28	washer, pl-b reg pltd 3/8	838206-071	9
29	washer, pl-b reg pltd 1/2	838208-112	8
30	eyebolt,5/16-18 x 1 1/8" pltd	839105-112	8
31	nut,retainer 5/16-18 .092	861405-092	10

(Continued on [page 71](#))

PLEASE NOTE: WHEN ORDERING PARTS, INDICATE SERIAL NUMBER OF COMPRESSOR

Section 8 ILLUSTRATIONS AND PARTS LIST

8.8 FLUID COOLING SYSTEM- AIR-COOLED 300-350HP/ 224-261KW

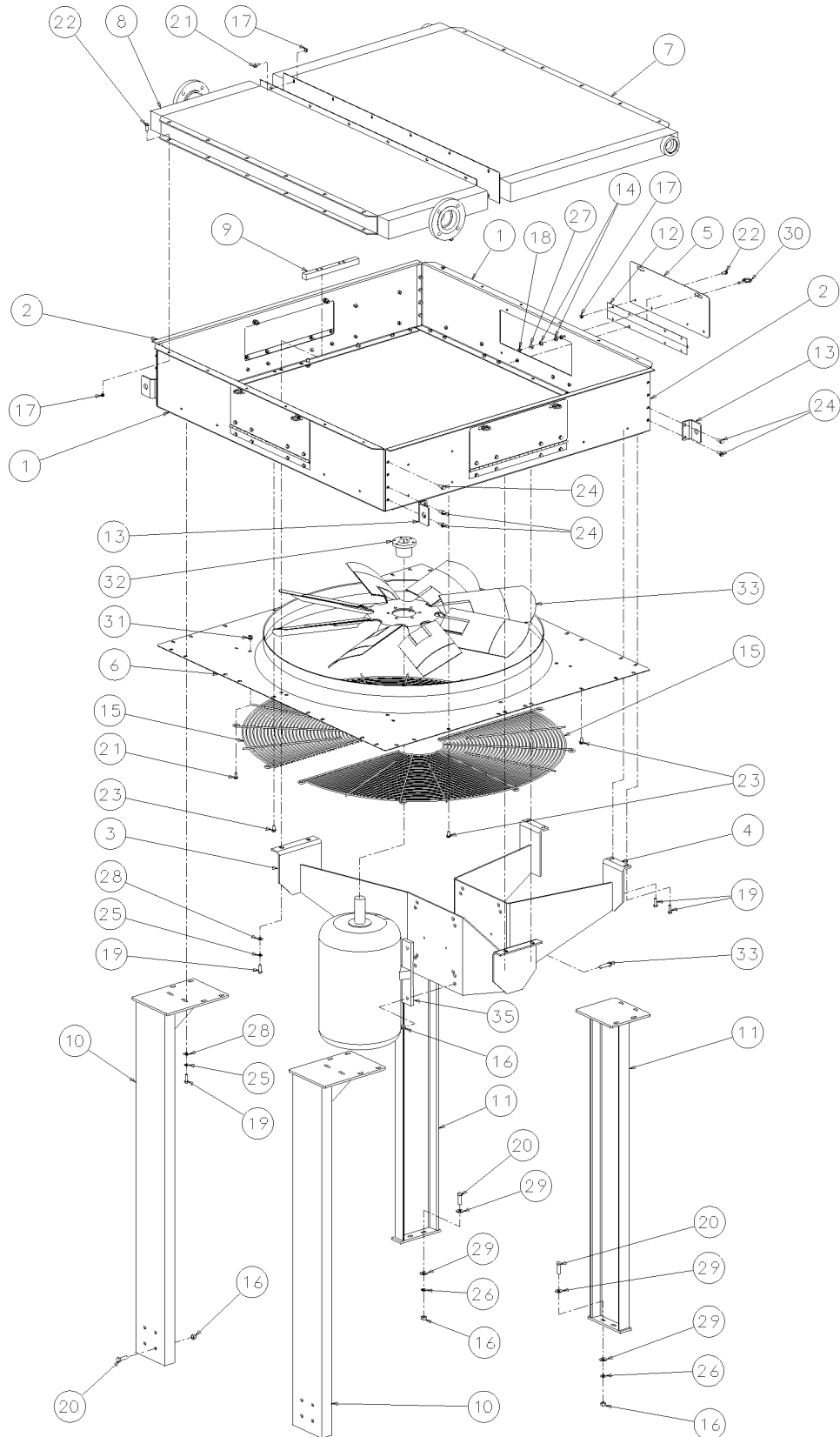

02250128-959R01

Section 8

ILLUSTRATIONS AND PARTS LIST

8.8 FLUID COOLING SYSTEM- AIR-COOLED 300-350HP/ 224-261KW (CONTINUED)

<i>key number</i>	<i>description</i>	<i>part number</i>	<i>quantity</i>
32	bushing (I)	-	1
33	capscr, hex gr5 1/2-13 x various len (I)	-	4
34	bushing (I)	-	1
35	motor (I)	-	1

(I) This item may vary with machine. Consult factory with machine serial number.

PLEASE NOTE: WHEN ORDERING PARTS, INDICATE SERIAL NUMBER OF COMPRESSOR

Section 8 ILLUSTRATIONS AND PARTS LIST

8.9 WATER COOLER PIPING- 200-350HP/ 149-261KW

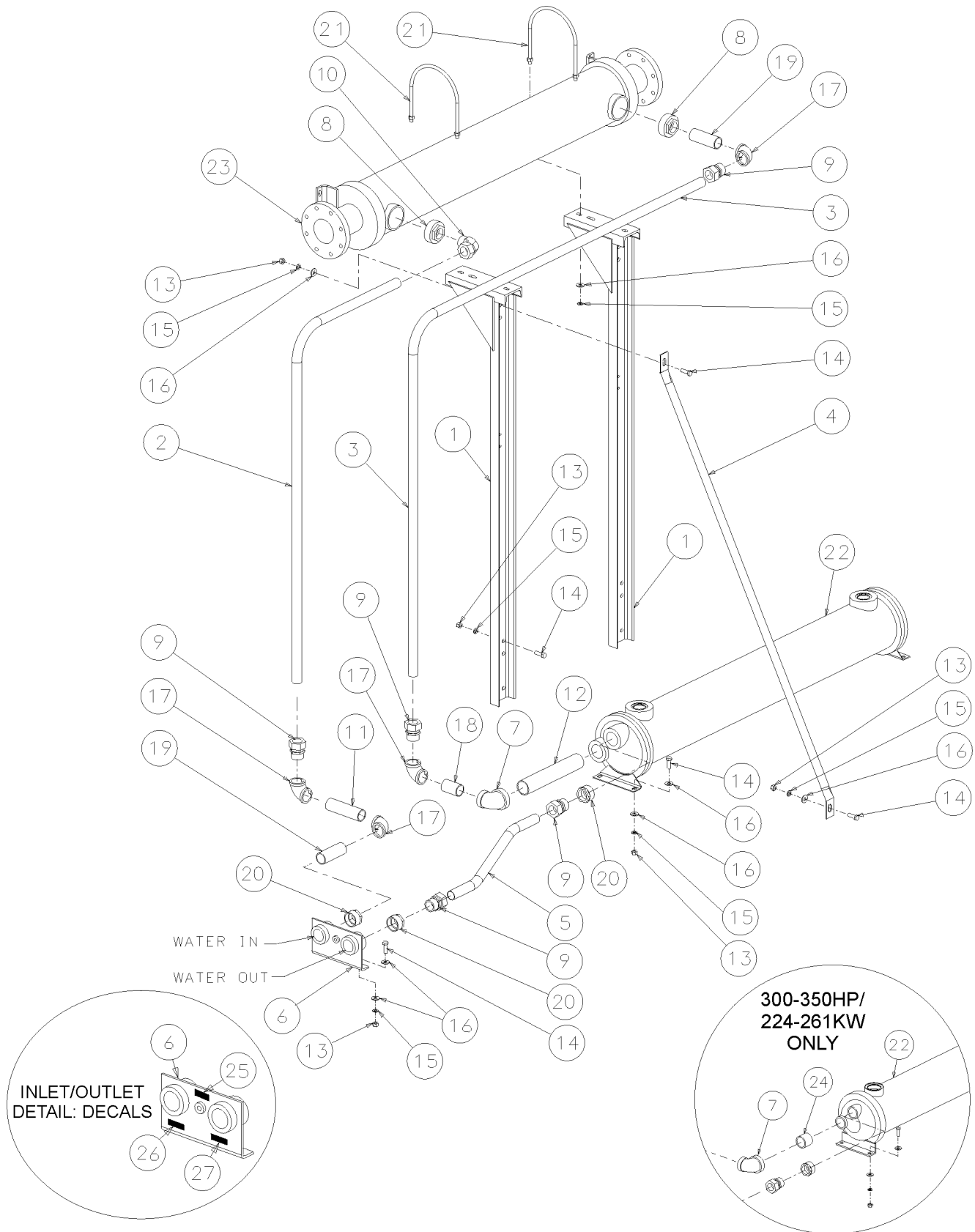

02250127-756R01 & 02250128-479R01

Section 8

ILLUSTRATIONS AND PARTS LIST

8.9 WATER COOLER PIPING- 200-350HP/ 149-261KW

<i>key number</i>	<i>description</i>	<i>part number</i>	<i>quantity</i>
1	support, aftercooler	02250124-430	2
2	tube, water in/aftclr 1-1/2" o.d.	02250124-618	1
3	tube,aftclr/oilclr 1-1/2" o.d.	02250124-619	1
4	support,wc aftclr/ac discharge pipe	02250128-850	1
5	tube,ts32-200/250wc serpp wtrout to	02250134-267	1
	•tube,ts32-300/350wc serpp wtrout to	02250134-347	1
6	bracket, 2" npt oil in/out	250008-245	1
7	elbow, red 2 x 1 1/2 150#	801608-060	1
8	bushing,red hx 3 x 1 1/2	802112-060	2
9	connector, tube-m 1 1/2 x 1 1/2	810224-150	5
10	elbow, tube 90 deg m 1 1/2 x 1 1/2	810524-150	1
11	nipple,pipe 1 1/2 x 6 1/2	822124-065	1
12	nipple,pipe 2 x 13 (250 only)	822132-130	1
13	nut,hex pltd 1/2-13	825208-448	16
14	capscr, hex gr5 1/2-13 x 1 1/2	829108-150	16
15	washer, spr lock reg pltd 1/2	837808-125	20
16	washer, pl-b reg pltd 1/2	838208-112	18
17	elbow, pipe 90 deg plt 1 1/2"	866215-060	4
18	nipple,pipe pltd 1 1/2 x 3	866324-030	1
19	nipple,pipe pltd 1 1/2 x 5	866324-050	2
20	bushing,red pltd 2 x 1 1/2	867108-060	3
21	u-bolt,1/2" x 8" pipe pltd	868308-800	2
22	cooler, fluid (I)	-	1
23	aftercooler (I)	-	1
24	nipple,pipe-xs plt 2 x cl (300-350 only)	866432-000	1
25	decal, water inlet-outlet	049873	1
26	decal, water in	250019-107	1
27	decal, water out	250019-108	1

(I) This item may vary with machine. Consult factory with machine serial number.

PLEASE NOTE: WHEN ORDERING PARTS, INDICATE SERIAL NUMBER OF COMPRESSOR

Section 8 ILLUSTRATIONS AND PARTS LIST

8.10 AIR PIPING SYSTEM- AIR-COOLED 200-350HP/ 149-261KW

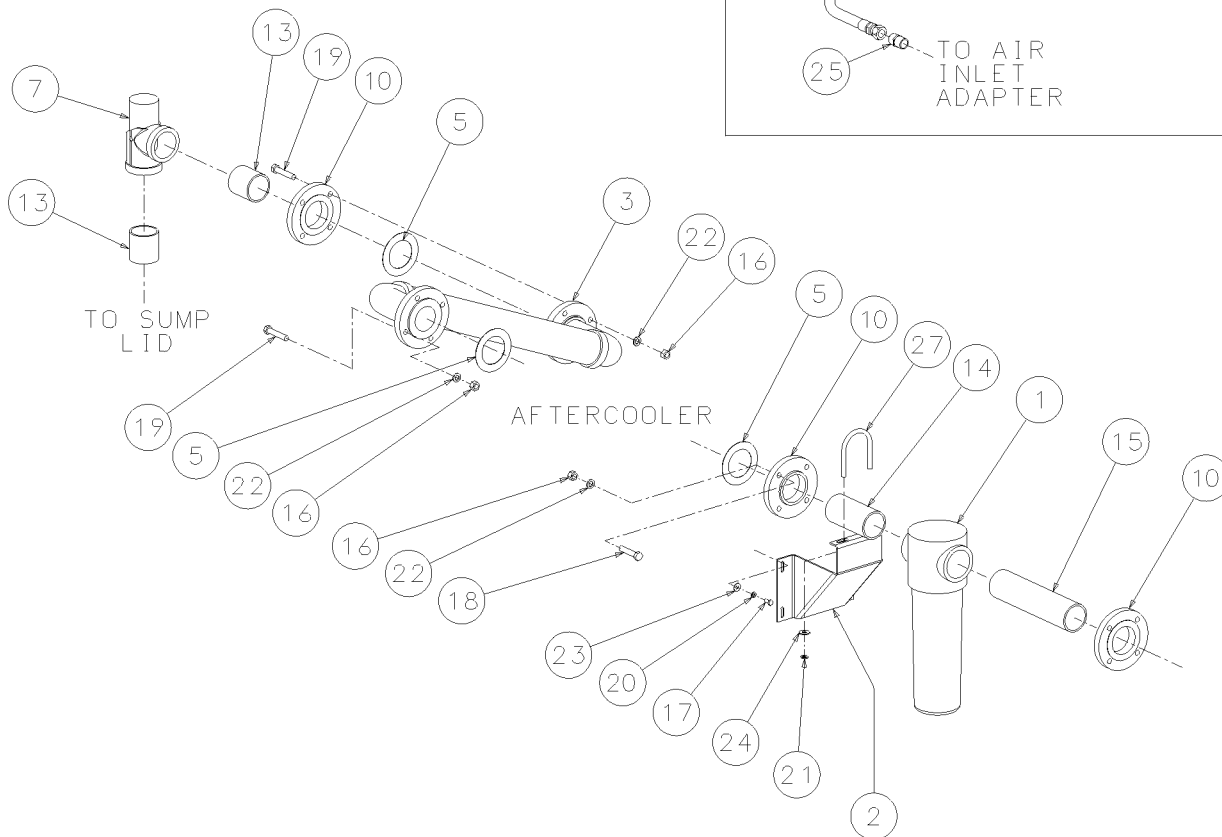
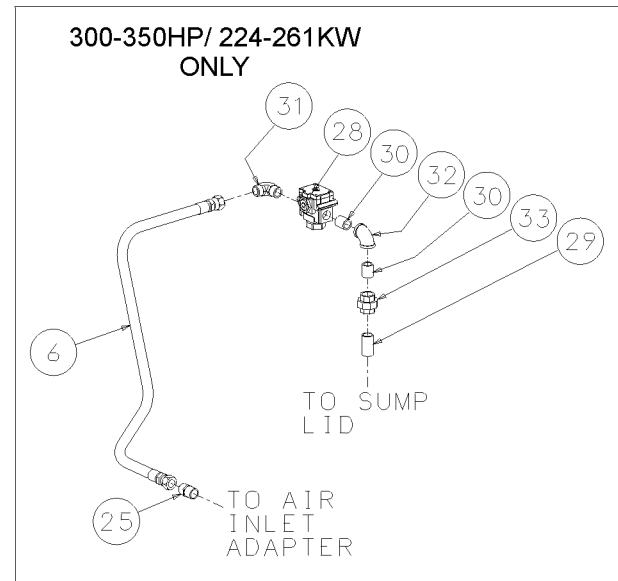
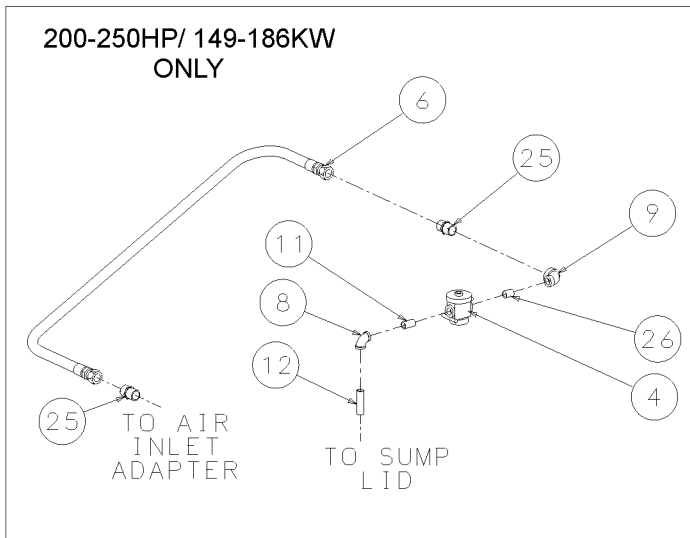

Section 8 ILLUSTRATIONS AND PARTS LIST

8.10 AIR PIPING SYSTEM- AIR-COOLED 200-350HP/ 149-261KW

<i>key number</i>	<i>description</i>	<i>part number</i>	<i>quantity</i>
1	separator, water dh ws800 3"npt (I)	02250111-105	1
2	bracket, seperator mount	02250121-831	1
3	joint, expansion ts32a-200/250ac mpv/intac	02250127-208	1
	•joint, expansion ts32a-300/350 mpv/intac	02250123-836	1
4	valve, 2-way pneumatic n.c. (II)	044912	1
5	gasket, asa flange 150# 3"	240621-008	3
6	hose,med. press. 1" x .068"	249616-015	1
7	valve, min press check 3" (spl) (III)	250033-821	1
8	elbow, pipe 90 deg 1/2" 150#	801515-020	1
9	elbow, red 1 x 1/2 150#	801604-020	1
10	flange, thrd 3" 150# rf	819315-048	3
11	nipple,pipe 1/2 x 1 1/2	822108-015	1
12	nipple,pipe 1/2 x 3	822108-030	1
13	nipple,pipe 3 x 3 1/2 (200-250hp/149-186kw)	822148-035	2
	•nipple,pipe 3 x 3 (300-350hp/224-261kw)	822148-030	2
14	nipple,pipe 3 x 7 (200-250hp/149-186kw)	822148-070	1
	•nipple,pipe 3 x 5 1/2 (300-350hp/224-261kw)	822148-055	1
15	nipple,pipe 3 x 14	822148-140	1
16	nut,hex pltd 5/8-11	825210-559	12
17	capscr, hex gr5 3/8-16 x 3/4	829106-075	4
18	capscr, hex gr5 5/8-11 x 3	829110-300	4
19	nipple,pipe pltd 1 1/2 x 5	866324-050	2
20	washer, spr lock reg pltd 3/8	837806-094	4
21	washer, spr lock reg pltd 1/2	837808-125	2
22	washer, spr lock reg pltd 5/8	837810-156	12
23	washer, pl-b reg pltd 3/8	838206-071	4
24	washer, pl-b reg pltd 1/2	838208-112	2
25	connector,37 fl/mpt pltd 1 x 1	860116-100	2

(Continued on [page 77](#))

(I) For maintenance on water separator no. 02250111-105, consult factory with machine serial number.

(II) For maintenance on pneumatic valve no. 044912, order repair kit no. 046782.

(III) For maintenance on minimum pressure check valve no. 250033-821, order repair kit no. 250018-262.

PLEASE NOTE: WHEN ORDERING PARTS, INDICATE SERIAL NUMBER OF COMPRESSOR

Section 8 ILLUSTRATIONS AND PARTS LIST

8.10 AIR PIPING SYSTEM- AIR-COOLED 200-350HP/ 149-261KW

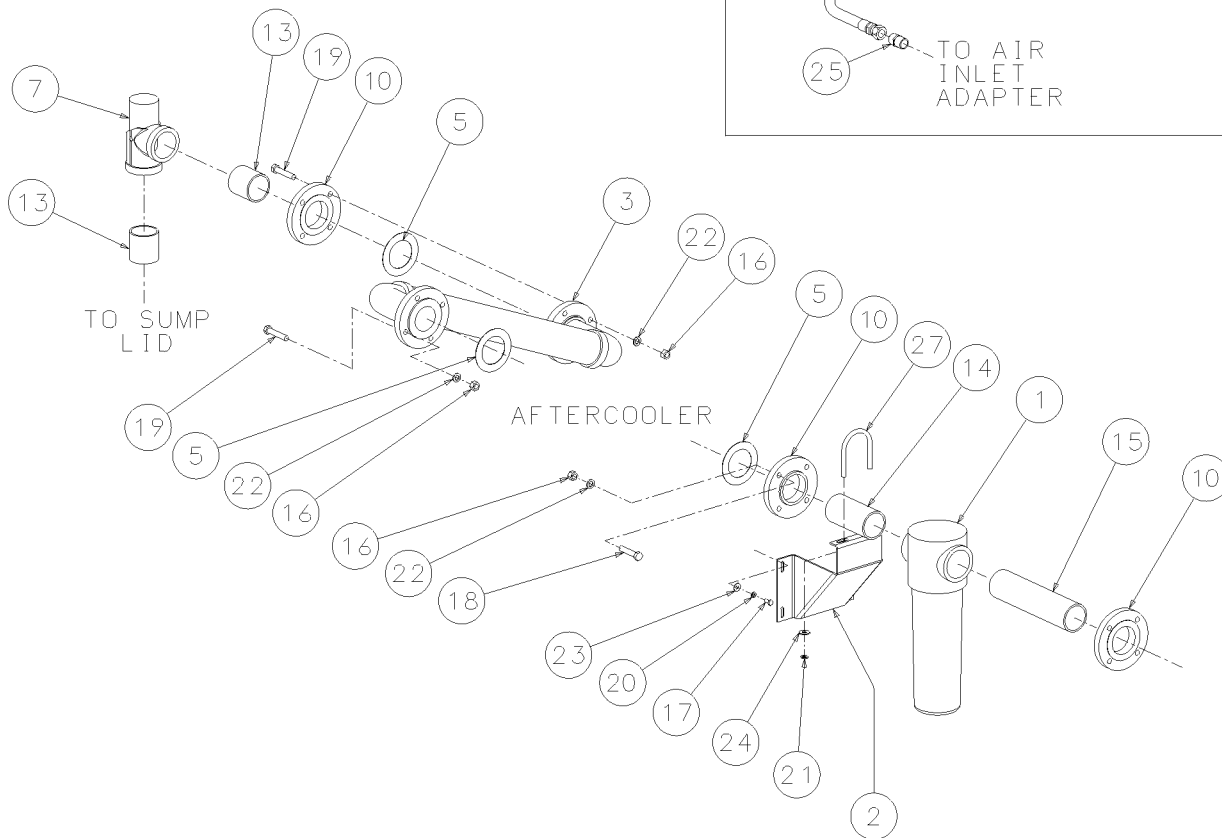
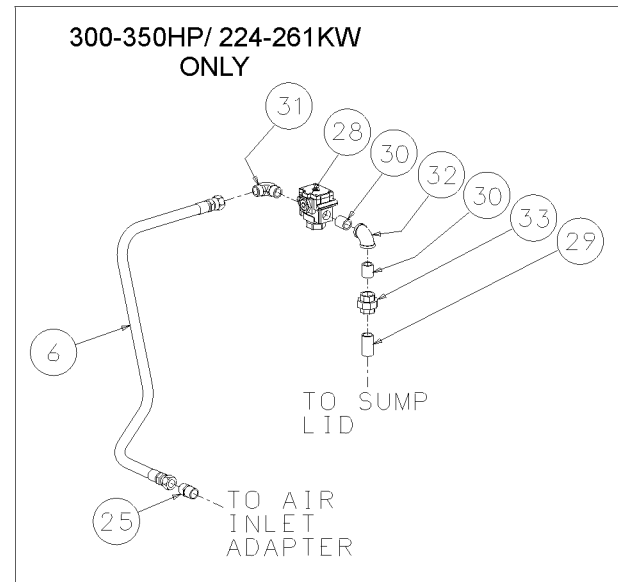
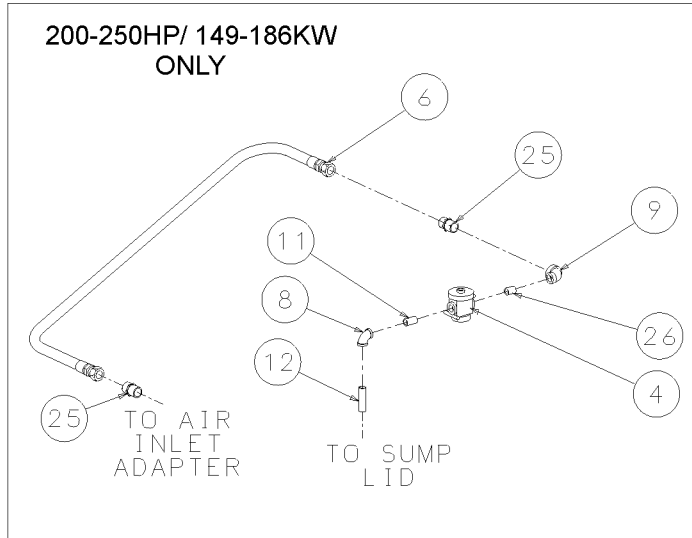

Section 8

ILLUSTRATIONS AND PARTS LIST

8.10 AIR PIPING SYSTEM- AIR-COOLED 200-350HP/ 149-261KW (CONTINUED)

<i>key number</i>	<i>description</i>	<i>part number</i>	<i>quantity</i>
26	nipple,pipe-xs plt 1/2 x cl	866408-000	1
27	u-bolt,1/2" x 3" pipe pltd	868308-300	1
28	valve, blwdwn 1"nc 2way #c6654 (IV)	409783	1
29	nipple,pipe 1 x 2 1/2	822116-025	1
30	nipple,pipe-xs 1 x cl	822216-000	2
31	elbow, 37fl 90m 1 x 1	860216-100	1
32	elbow, pipe 90 deg plt 1"	866215-040	1
33	union,pipe-brs seat 1 150#	871615-040	1

(IV) For maintenance on blowdown valve no. 409783, order repair kit no. 001667.

PLEASE NOTE: WHEN ORDERING PARTS, INDICATE SERIAL NUMBER OF COMPRESSOR

Section 8 ILLUSTRATIONS AND PARTS LIST

8.11 AIR PIPING SYSTEM- WATER-COOLED 200-350HP/ 149-261KW

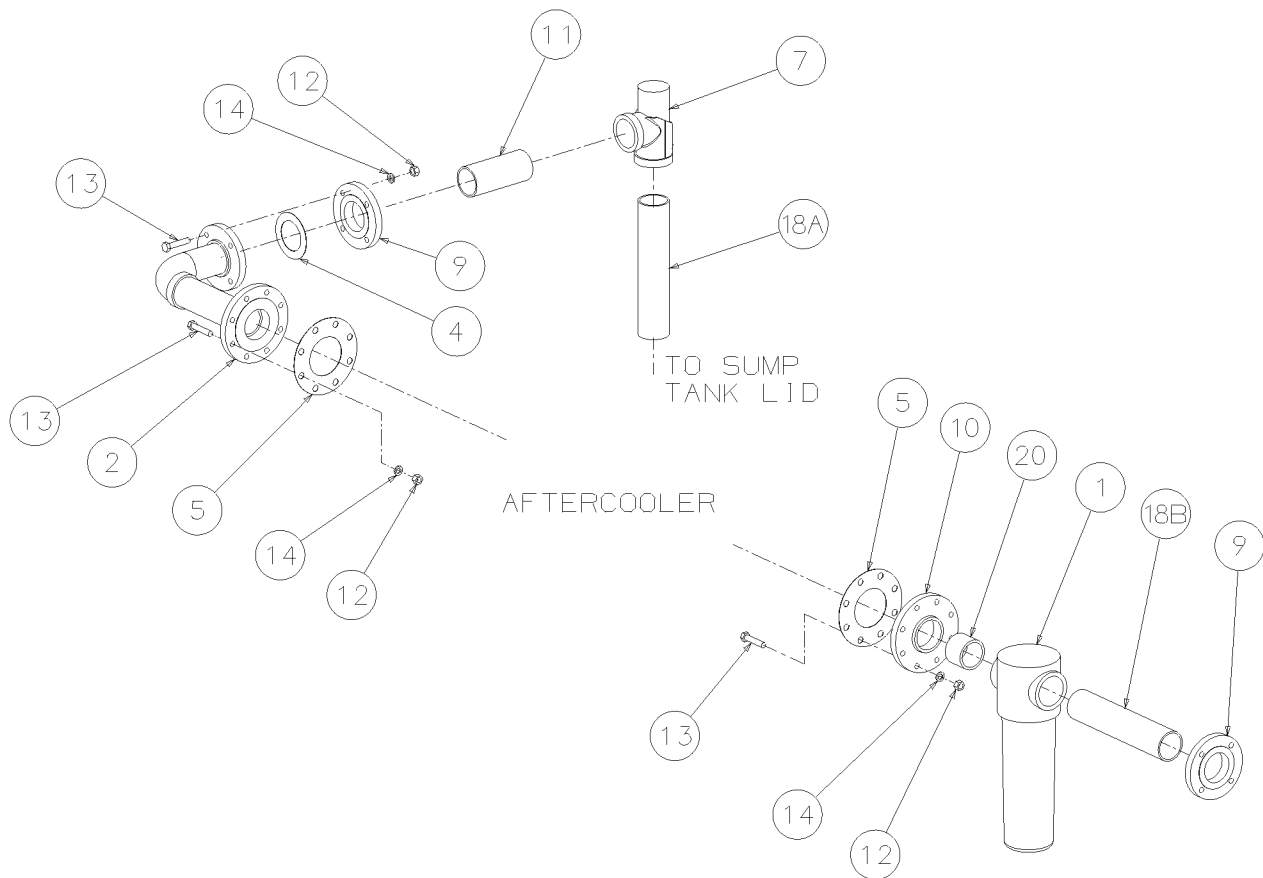
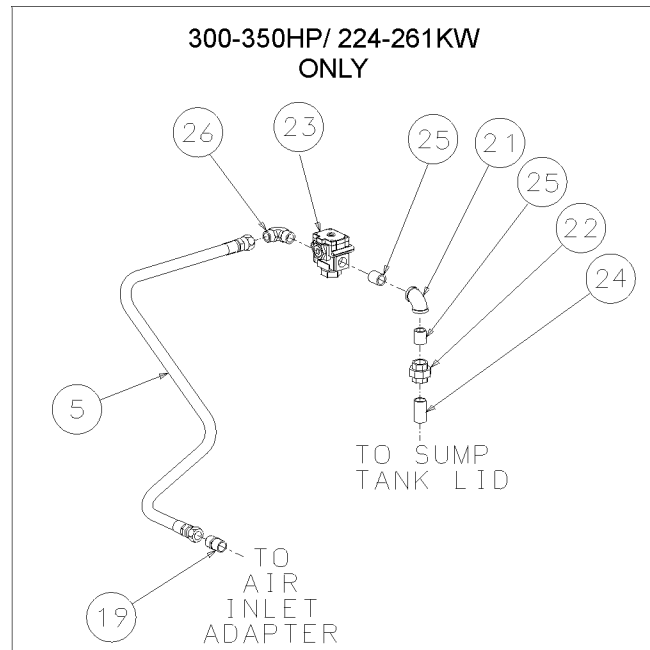
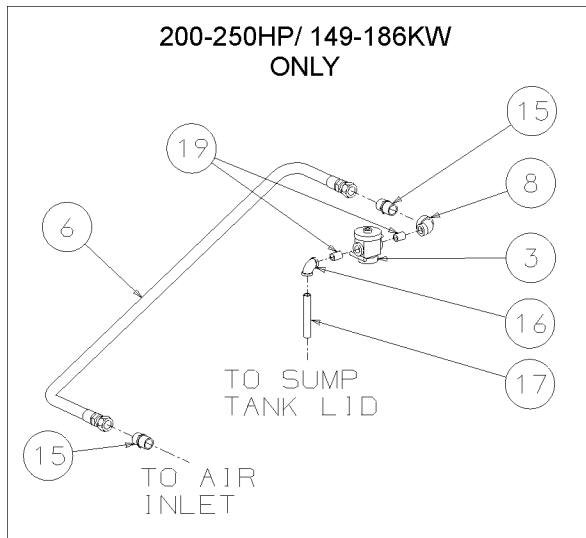

02250128-576R01&02250128-577R01

Section 8

ILLUSTRATIONS AND PARTS LIST

8.11 AIR PIPING SYSTEM- WATER-COOLED 200-350HP/ 149-261KW

<i>key number</i>	<i>description</i>	<i>part number</i>	<i>quantity</i>
1	separator, water dh ws800 3"npt (I)	02250111-105	1
2	joint, expansion mpv to aftclr 3" dia.	02250124-433	1
3	valve, 2-way pneumatic n.c. (II)	044912	1
4	gasket, asa flange 150# 3"	240621-008	1
5	gasket, 4" 125# flg full face	242437-010	2
6	hose,med press 1 x .068	249616-015	1
7	valve, min press check 3" (spl) (III)	250033-821	1
8	elbow, red 1 x 1/2 150#	801604-020	1
9	flange, thrd 3" 150# rf	819315-048	2
10	flange, thrd red 3 x 9"	819548-090	1
11	nipple,pipe 3 x 8 (200-250hp/149-186kw)	822148-080	1
	•nipple,pipe 3 x 3 1/2 (300-350hp/224-261kw)	822148-035	1
12	nut,hex pltd 5/8-11	825210-559	20
13	capscr, hex gr5 5/8-11 x 3	829110-300	20
14	washer, spr lock reg pltd 5/8	837810-156	20
15	connector,37 fl/mpt pltd 1 x 1	860116-100	2
16	elbow, pipe 90 deg plt 1/2"	866215-020	1
17	nipple,pipe pltd 1/2 x 5	866308-050	1
18A	nipple,pipe pltd 3 x 16 (200-250hp/149-186kw)	866348-160	2
	•nipple,pipe 3 x 6 1/2 (300-350hp/224-261kw)	822148-065	1
18B	nipple,pipe pltd 3 x 16 (200-250hp/149-186kw)	866348-160	2
	•nipple,pipe 3 x 20 (300-350hp/224-261kw)	822148-200	1
19	nipple,pipe-xs plt 1/2 x cl	866408-000	2
20	nipple,pipe-xs plt 3 x cl	866448-000	1
21	elbow, pipe 90 deg plt 1"	866215-040	1
22	union,pipe-brs seat 1 150#	871615-040	1
23	valve, blwdwn 1"nc 2way #c6654 (IV)	409783	1
24	nipple,pipe 1 x 2 1/2	822116-025	1
25	nipple,pipe-xs 1 x cl	822216-000	2
26	elbow, 37fl 90m 1 x 1	860216-100	1

(I) For maintenance on water separator no. 02250111-105, consult factory with machine serial number.

(II) For maintenance on pneumatic valve no. 044912, order repair kit no. 046782.

(III) For maintenance on minimum pressure check valve no. 250033-821, order repair kit no. 250018-262.

(IV) For maintenance on blowdown valve no. 409783, order repair kit no. 001667.

PLEASE NOTE: WHEN ORDERING PARTS, INDICATE SERIAL NUMBER OF COMPRESSOR

Section 8 ILLUSTRATIONS AND PARTS LIST

8.12 AIR PIPING SYSTEM- REMOTE COOLER 300-350HP/ 224-261KW

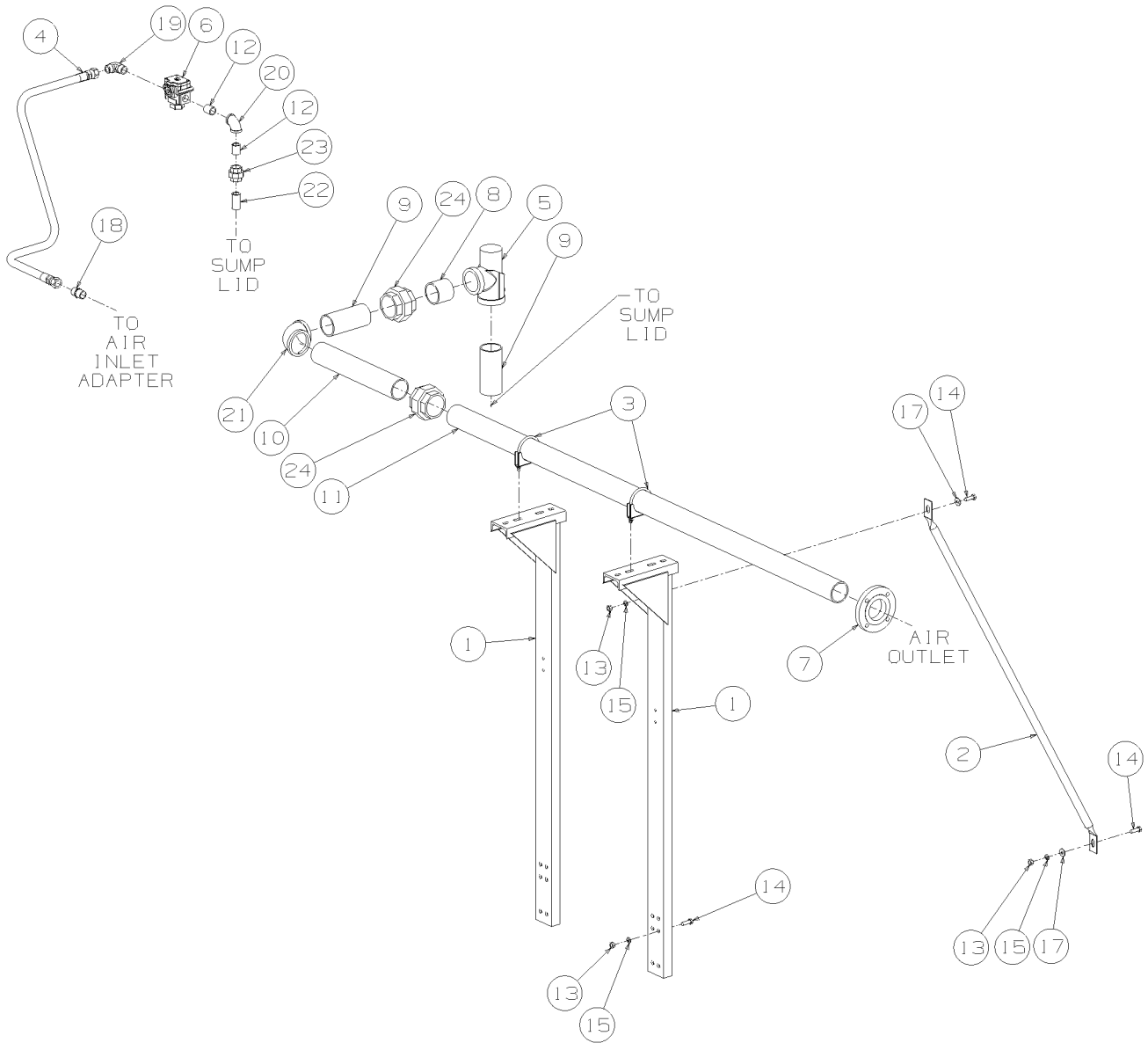

Section 8

ILLUSTRATIONS AND PARTS LIST

8.12 AIR PIPING SYSTEM- REMOTE COOLER 300-350HP/ 224-261KW

<i>key number</i>	<i>description</i>	<i>part number</i>	<i>quantity</i>
1	support, aftercooler	02250124-430	2
2	support,wc aftclr/ac discharge pipe	02250128-850	1
3	clamp, exhaust 3 1/2"	040284	2
4	hose,med press 1.00 x .068"	249616-015	1
5	valve, min press check 3" (spl) (I)	250033-821	1
6	valve, blwdwn 1"nc 2way #c6654 (II)	409783	1
7	flange, thrd 3" 150# rf	819315-048	1
8	nipple,pipe 3 x 3	822148-030	1
9	nipple,pipe 3 x 7 1/2	822148-075	2
10	nipple,pipe 3 x 20	822148-200	1
11	nipple,pipe 3 x 96	822148-960	1
12	nipple,half-xs 1 x cl	822416-000	2
13	nut,hex pltd 1/2-13	825208-448	10
14	capscr, hex gr5 1/2-13 x 1 1/2	829108-150	10
15	washer, spr lock reg pltd 1/2	837808-125	10
16	washer, pl-b reg pltd 3/8	838206-071	4
17	washer, pl-b reg pltd 1/2	838208-112	2
18	connector,37 fl/mpt pltd 1 x 1	860116-100	1
19	elbow, 37fl 90m 1 x 1	860216-100	1
20	elbow, pipe 90 deg plt 1"	866215-040	1
21	elbow, pipe 90 deg plt 3"	866215-120	1
22	nipple,pipe-xs plt 1 x 2 1/2	866416-025	1
23	union,pipe-brs seat 1 150#	871615-040	1
24	union,pipe-brs seat 3 150#	871615-120	2

(I) For maintenance on minimum pressure check valve no. 250033-821, order repair kit no. 250018-262.

(II) For maintenance on blowdown valve no. 409783, order repair kit no. 001667.

PLEASE NOTE: WHEN ORDERING PARTS, INDICATE SERIAL NUMBER OF COMPRESSOR

Section 8 ILLUSTRATIONS AND PARTS LIST

8.13 FLUID PIPING SYSTEM- AIR-COOLED & WATER-COOLED 200-250HP/ 149-186KW

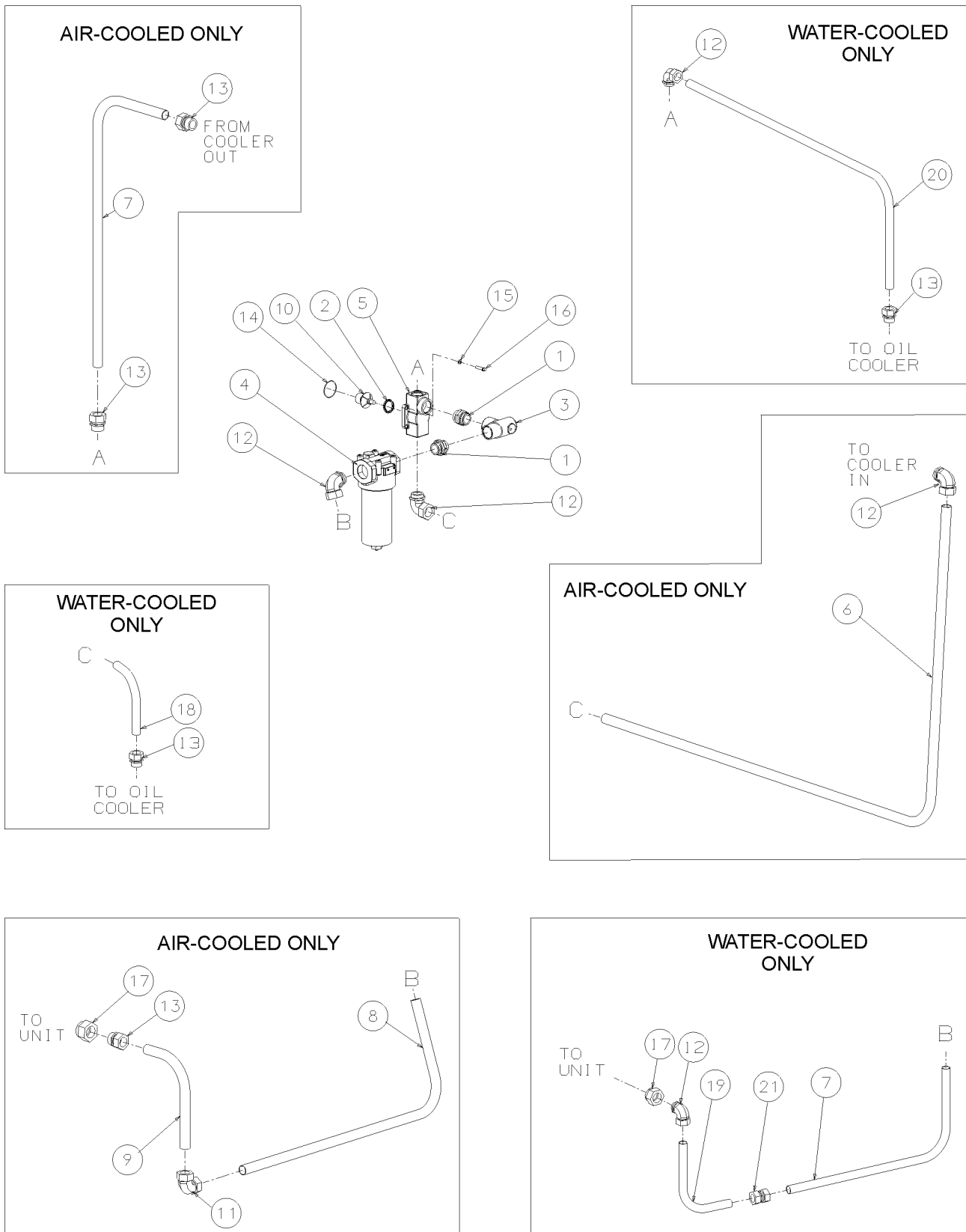

02250130-765R01&02250132-477R01

Section 8

ILLUSTRATIONS AND PARTS LIST

8.13 FLUID PIPING SYSTEM- AIR-COOLED & WATER-COOLED 200-250HP/ 149-186KW

<i>key number</i>	<i>description</i>	<i>part number</i>	<i>quantity</i>
1	adapter, sae 1 7/8-12 x 1 7/8-12	02250055-014	2
2	seal,u-cup viton thermal vlv (I)	02250101-372	1
3	valve, oil stop (II)	02250113-668	1
4	filter,1 7/8-12 sae coreless (III)	02250121-658	1
5	housing,therm vlv 1 7/8"-12 conn w/ ext (I)	02250127-119	1
	•valve, thermal (195°) (24KT & water-cooled compressors rated \geq 150 psig) (IV)	02250127-962	1
6	tube,1-1/2" thrmvlv/clr ts32a-200/250	02250127-347	1
7	tube,1-1/2" clr/thrmvlv ts32a-200/250	02250127-349	1
8	tube, oil return oilfltr/union 1-1/2 (air-cooled)	02250127-351	1
	•tube, oil return 1-1/2" (water-cooled)	02250126-478	1
9	tube, oil return union/unit 1-1/2"	02250127-353	1
10	element, thermal valve 175deg f. (I)	049542	1
11	elbow, tube union 1 1/2	811224-150	1
12	elbow, tube str thrd 1 1/2 x 1 7/8 (air-cooled)	811624-188	3
	•elbow, tube str thrd 1 1/2 x 1 7/8 (water-cooled)	811624-188	4
13	connector, tube str thd 1 1/2 x 1 7/8 (air-cooled)	811824-188	3
	•connector, tube str thd 1 1/2 x 1 7/8 (water-cooled)	811824-188	2
14	o-ring, viton 2 1/2 x 3/32" (I)	826502-144	1
15	washer, spr lock reg pltd 3/8	837806-094	4
16	capscrew, ferry head hd pltd 3/8-16 x 1 1/2	867306-150	4
17	reducer,str thrd viton 2 1/2 x 1 1/2	870032-024	1
18	tube,thermal valve to oil cooler	02250126-426	1
19	tube, oil return 1-1/2"	02250126-476	1
20	tube,oc/thrmvlv ts32-200/250 1-1/2"w	02250134-340	1
21	union,tube hex 1 1/2"	811324-150	1

(I) For maintenance on thermal valve rated at 175°, order replacement kit no. 02250105-553.

(II) For maintenance on oil stop valve no. 02250113-668, consult factory for replacement parts list.

(III) For maintenance on coreless filter no. 02250121-658, order replacement element no. 02250121-657.

(IV) For maintenance on thermal valve no. 02250127-962 (24KT and water-cooled compressors rated \geq 150 psig), order repair kit no. 02250112-709.

PLEASE NOTE: WHEN ORDERING PARTS, INDICATE SERIAL NUMBER OF COMPRESSOR

Section 8 ILLUSTRATIONS AND PARTS LIST

8.14 FLUID PIPING SYSTEM- AIR-COOLED & WATER-COOLED 300-350HP/ 224-261KW

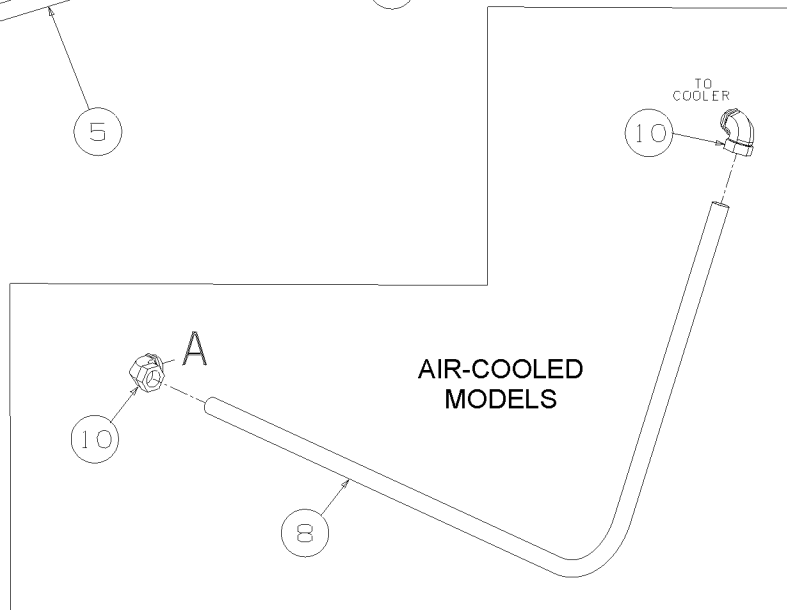
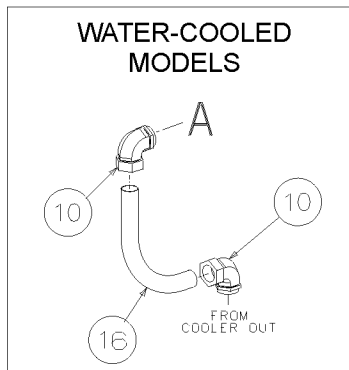
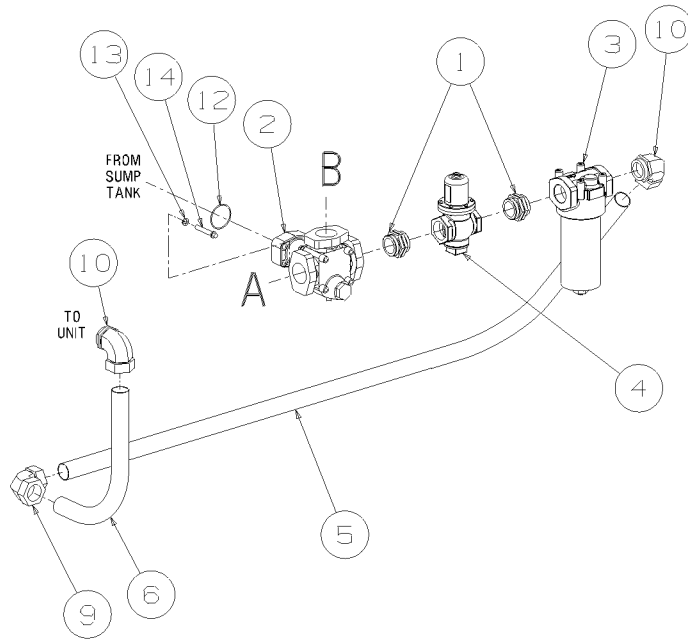
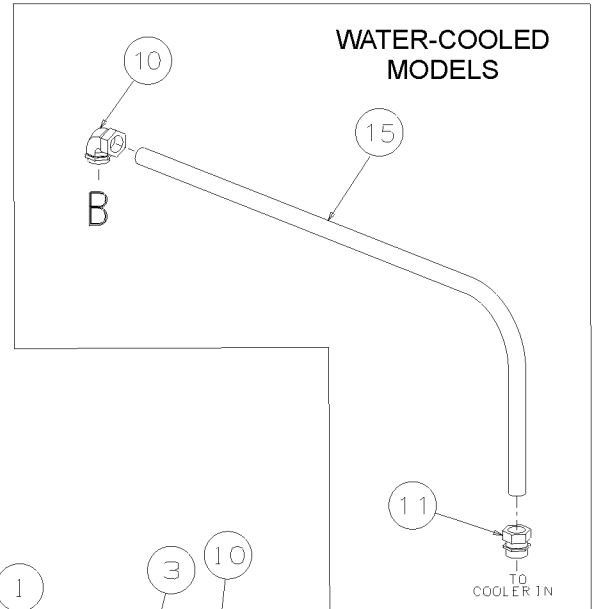
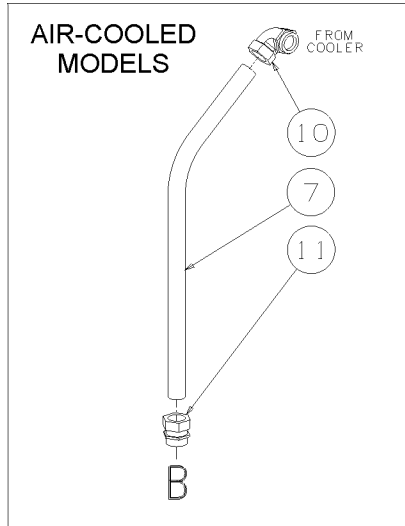

Section 8

ILLUSTRATIONS AND PARTS LIST

8.14 FLUID PIPING SYSTEM- AIR-COOLED & WATER-COOLED 300-350HP/ 224-261KW

<i>key number</i>	<i>description</i>	<i>part number</i>	<i>quantity</i>
1	adapter, sae 2-1/2-12 x 2-1/2-12	02250110-661	2
2	valve, thermal 2.5" sae 170deg (I) •valve, thermal (195°) (24KT & water-cooled compressors rated \geq 150 psig) (II)	02250120-955	1
3	filter, 1 7/8-12 sae coreless (air-cooled) (III) •filter, 2-1/2 sae coreless 80cn-1 (water-cooled) (IV)	02250127-962	1
4	valve, oil stop 2.5" sae (V)	02250121-658	1
5	tube, oilfltr/elbow 2" o.d.	02250128-717	1
6	tube, elbow/unit 2" o.d.	02250122-004	1
7	tube, thrmvlv/intac 2" o.d.	02250124-659	1
8	tube, intac/thrmvlv 2" o.d.	02250124-660	1
9	elbow, tube union 2	02250124-662	1
10	elbow, tube str thrd 2 x 2 1/2	02250124-663	1
11	connector, tube str thd 2 x 2 1/2	811232-200	1
12	o-ring, viton 2 3/4 x 1/8"	811632-250	5
13	washer, spr lock reg pltd 1/2	811832-250	1
14	capscrew, ferry head hd pltd 1/2-13 x 3	826502-232	1
15	tube, oilclr/thrmvlv 2" o.d.	837808-125	4
16	tube, thrmvlv/oilclr 2" o.d.	867308-300	4

(I) For maintenance on thermal valve no. 02250120-955, order replacement kit no. 02250120-957.

(II) For maintenance on thermal valve no. 02250127-962 (24KT and water-cooled compressors rated \geq 150 psig), order repair kit no. 02250112-709.

(III) For maintenance on coreless filter no. 02250121-658, order replacement element no. 02250121-657.

(IV) For maintenance on coreless filter no. 02250128-717, order replacement element no. 02250121-657.

(V) For maintenance on oil stop valve no. 02250122-004, order repair kit no. 001684.

PLEASE NOTE: WHEN ORDERING PARTS, INDICATE SERIAL NUMBER OF COMPRESSOR

Section 8 ILLUSTRATIONS AND PARTS LIST

8.15 FLUID PIPING SYSTEM- REMOTE COOLER 300-350HP/ 224-261KW

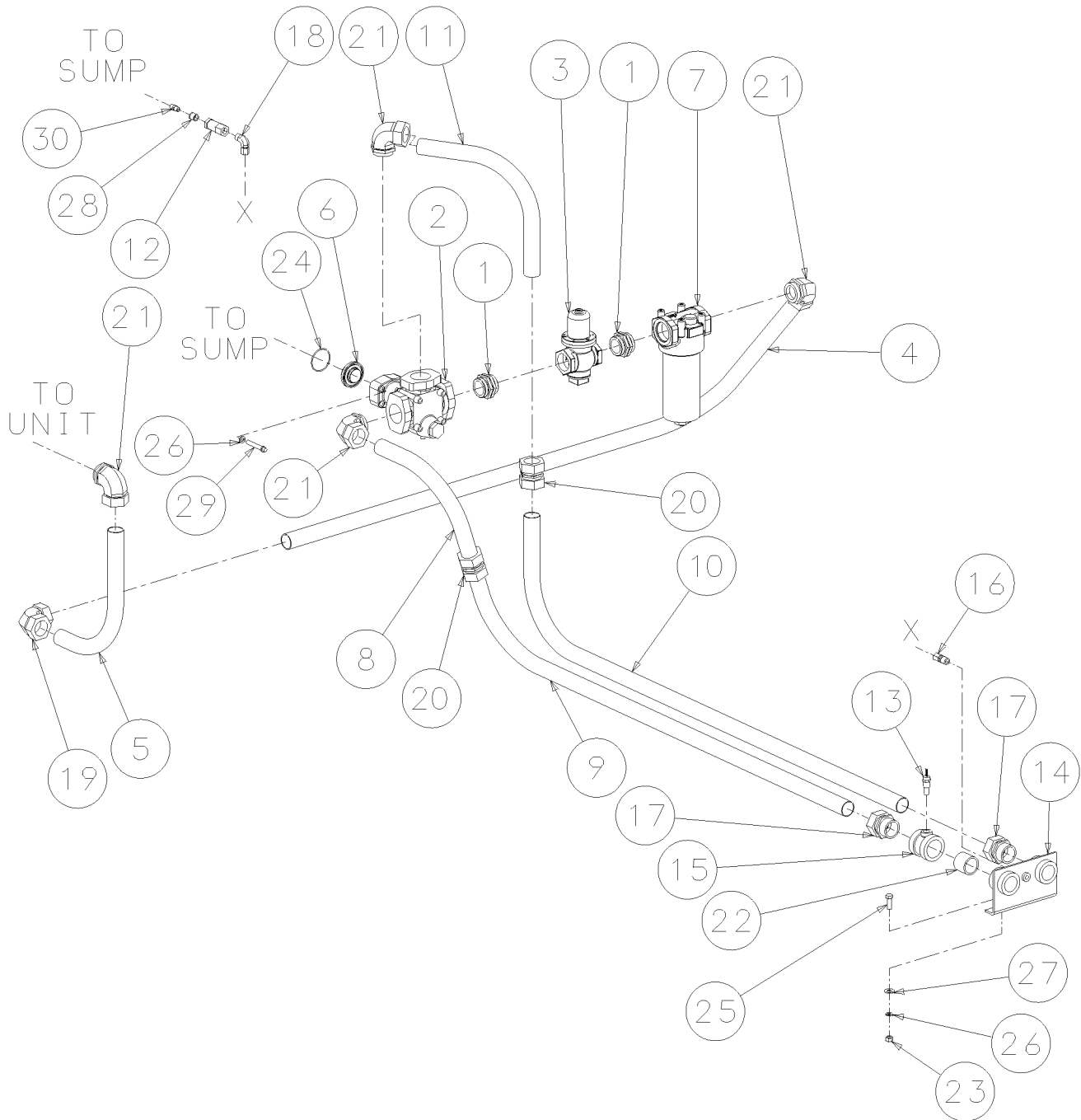

Section 8

ILLUSTRATIONS AND PARTS LIST

8.15 FLUID PIPING SYSTEM- REMOTE COOLER 300-350HP/ 224-261KW

<i>key number</i>	<i>description</i>	<i>part number</i>	<i>quantity</i>
1	adapter, sae 2-1/2-12 x 2-1/2-12	02250110-661	2
2	valve, thermal 2.5" sae 170deg (I)	02250120-955	1
	•valve, thermal (195°) (24KT & water-cooled compressors rated \geq 150 psig) (II)	02250127-962	1
3	valve, oil stop 2.5" sae (III)	02250122-004	1
4	tube,oilfltr/elbow 2" o.d.	02250124-659	1
5	tube,elbow/unit 2" o.d.	02250124-660	1
6	2-1/2" sae check valve insert	02250125-617	1
7	filter, 2-1/2 sae coreless 80cn-1 (IV)	02250128-717	1
8	tube,2"dia ts32-300rc thrmvlv to un	02250129-215	1
9	tube,2"dia ts32-300rc union to oil	02250129-219	1
10	tube,2"dia ts32-300rc oil in to uni	02250129-221	1
11	tube,2"dia ts32-300rc union to thrm	02250129-223	1
12	valve, check 1/2"	042694	1
13	switch, temp n.o. 115f	043239	1
14	bracket, 2" npt oil in/out	250008-245	1
15	tee,reducing 2 x 2 x 1/2	802208-082	1
16	connector, tube-m 1/2 x 1/2	810208-050	1
17	connector, tube-m 2 x 2	810232-200	2
18	elbow, tube 90 deg m 1/2 x 1/2	810508-050	1
19	elbow, tube union 2	811232-200	1
20	union,tube hex 2"	811332-200	2
21	elbow, tube str thrd 2 x 2 1/2	811632-250	4
22	nipple,pipe-xs 2 x cl	822232-000	1
23	nut,hex pltd 1/2-13	825208-448	2

(Continued on [page 89](#))

(I) For maintenance on thermal valve no. 02250120-955, order replacement kit no. 02250120-957.

(II) For maintenance on thermal valve no. 02250127-962 (24KT and water-cooled compressors rated > 150 psig), order repair kit no. 02250112-709,

(III) For maintenance on oil stop valve no. 02250122-004, order repair kit no. 001684.

(IV) For maintenance on coreless filter no. 02250128-717, order replacement element no. 02250121-657.

PLEASE NOTE: WHEN ORDERING PARTS, INDICATE SERIAL NUMBER OF COMPRESSOR

Section 8 ILLUSTRATIONS AND PARTS LIST

8.15 FLUID PIPING SYSTEM- REMOTE COOLER 300-350HP/224-261KW

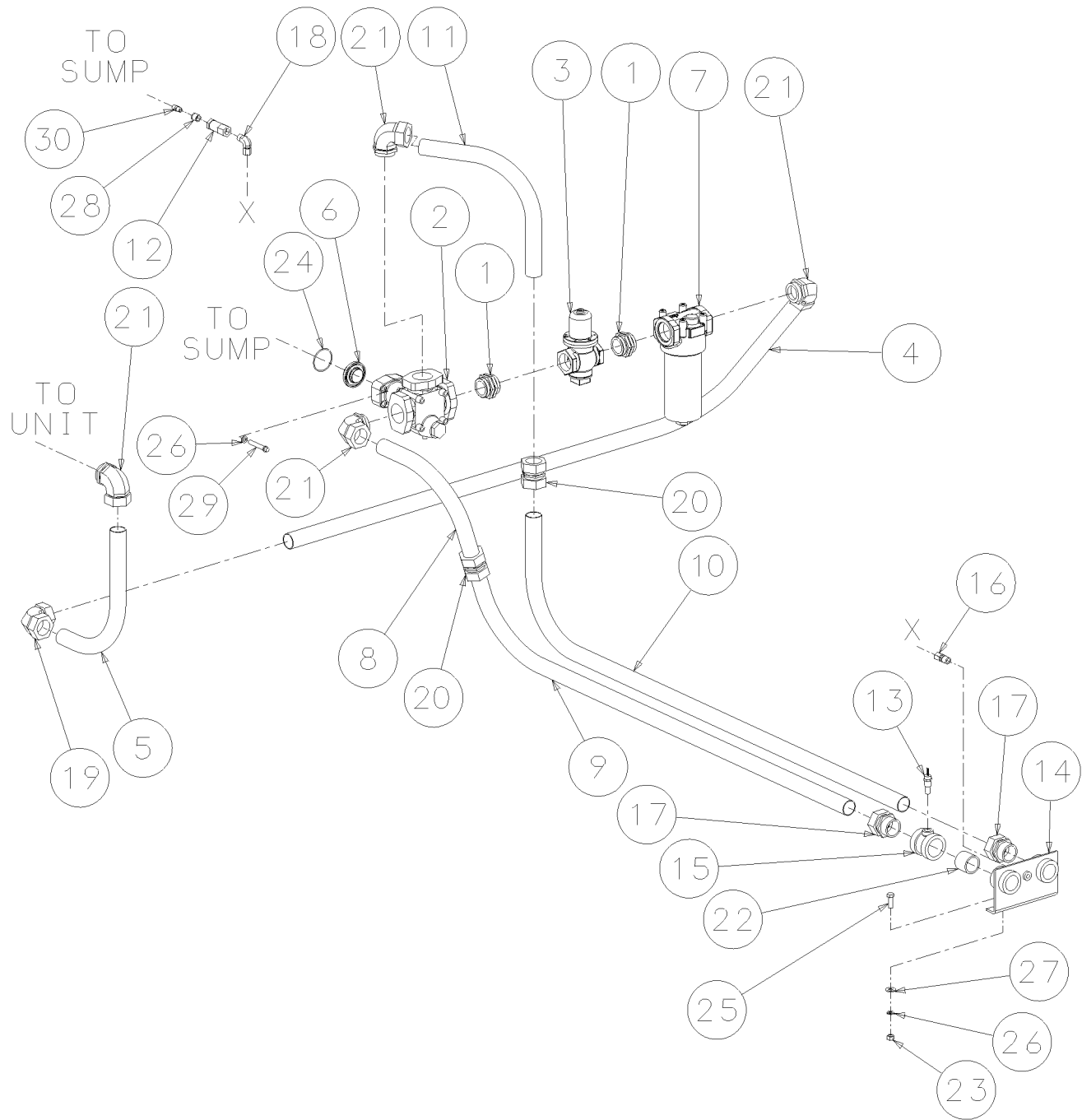

Section 8

ILLUSTRATIONS AND PARTS LIST

8.15 FLUID PIPING SYSTEM- REMOTE COOLER 300-350HP/224-261KW (CONTINUED)

<i>key number</i>	<i>description</i>	<i>part number</i>	<i>quantity</i>
24	o-ring, viton 2 3/4 x 1/8"	826502-232	1
25	capscr, hex gr5 1/2-13 x 1 1/2	829108-150	2
26	washer, spr lock reg pltd 1/2	837808-125	6
27	washer, pl-b reg pltd 1/2	838208-112	2
28	bushing,red pltd 1/2 x 1/4	867102-010	1
29	capscrew, ferry head hd pltd 1/2-13 x 3	867308-300	4
30	nipple,pipe-hx pltd 1/4 x 1/4	868504-025	1

PLEASE NOTE: WHEN ORDERING PARTS, INDICATE SERIAL NUMBER OF COMPRESSOR

Section 8 ILLUSTRATIONS AND PARTS LIST

8.16 SUMP AND PARTS- 200-250HP/ 149-186KW

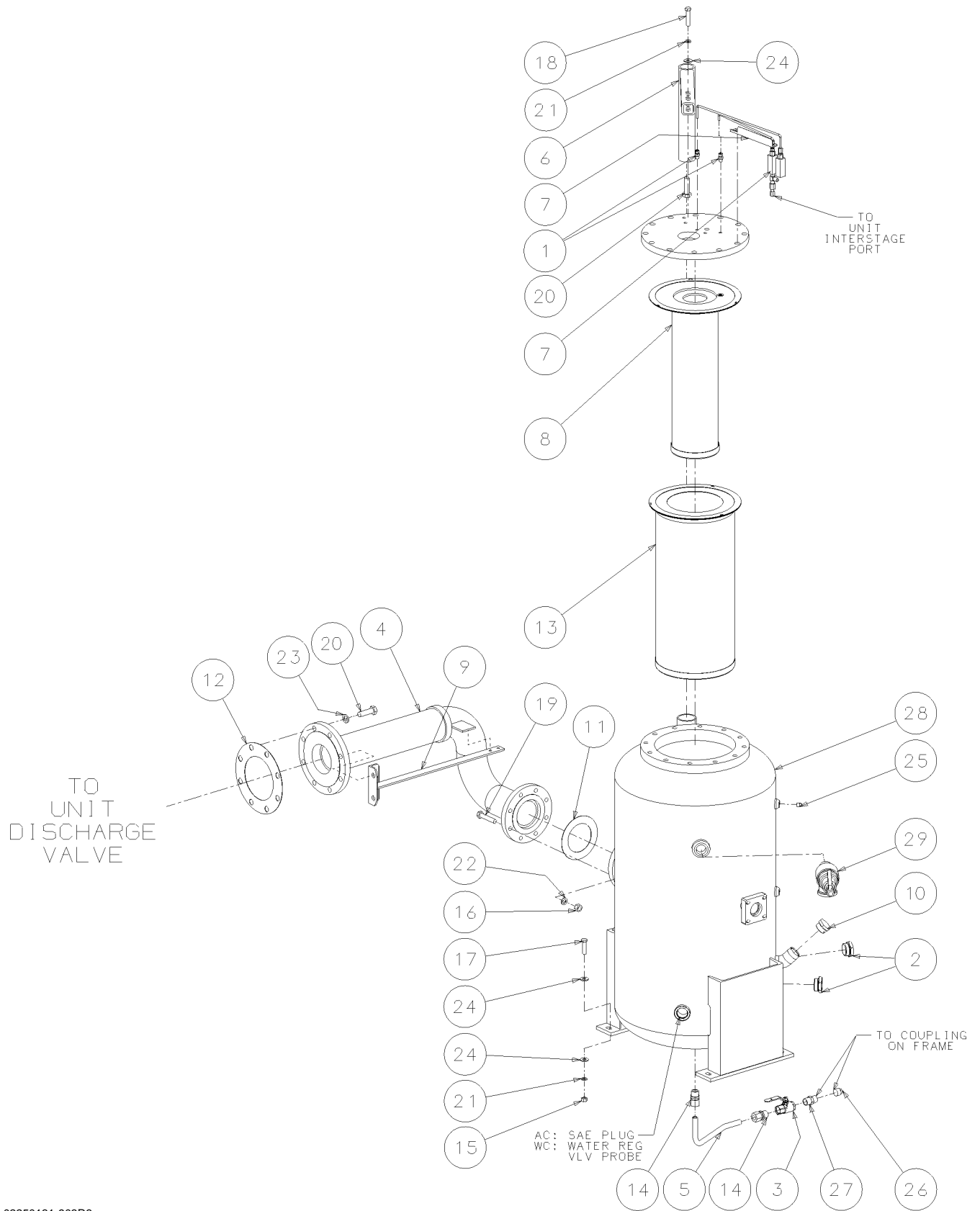

Section 8

ILLUSTRATIONS AND PARTS LIST

8.16 SUMP AND PARTS- 200-250HP/ 149-186KW

<i>key number</i>	<i>description</i>	<i>part number</i>	<i>quantity</i>
1	connector,flex 1/4t x 1/4p	020169	2
2	plug,sight glass 1-7/8" sae	02250097-611	2
3	valve, ball 3/4"sae x 3/4"npt	02250125-221	1
4	joint, expansion unit/sump ts32a-200/250hp	02250126-431	1
5	tube, sump drain 3/4"	02250126-483	1
6	boom,lid lifting	02250127-249	1
7	sub assembly,oil rtn/sight gls line	02250129-876	1
8	element, secondary separator (I)	02250131-223	1
9	support,ts32-200/350 disch.flex hose	02250136-549	1
10	plug,o-ring boss sae 1 1/4	040029	1
11	gasket, asa flange 150# 4"	240621-010	1
12	gasket, 6" 125# flg full face	242437-012	1
13	element, primary 25-200 (I)	250034-121	1
14	connector, tube str thd 3/4 x 1 1/16	811812-106	2
15	nut,hex pltd 1/2-13	825208-448	4
16	nut,hex pltd 5/8-11	825210-559	8
17	capscr, hex gr5 1/2-13 x 2	829108-200	4
18	capscr, hex gr5 1/2-13 x 2 1/2	829108-250	2
19	capscr, hex gr5 5/8-11 x 3 1/4	829110-325	8
20	capscr, hex gr5 3/4-10 x 2 1/2	829112-250	9
21	washer, spr lock reg pltd 1/2	837808-125	6
22	washer, spr lock reg pltd 5/8	837810-156	8
23	washer, spr lock reg pltd 3/4	837812-188	8
24	washer, pl-b reg pltd 1/2	838208-112	10
25	plug, pipe 1/4" 3000# stl plt	866900-010	1
26	plug, pipe 3/4" 3000# stl plt	866900-030	1
27	nipple,pipe-hx pltd 3/4 x 3/4	868512-075	1
28	tank, oil sump 24" vert std (II)	-	1
29	valve, relief 1-1/2" 1950cfm viton s (II)	-	1

(I) For maintenance on separator elements, order (primary) replacement element no. 250034-122, and (secondary) replacment element no. 02250131-225.

(II) This item may vary with machine. Consult factory with machine serial number.

PLEASE NOTE: WHEN ORDERING PARTS, INDICATE SERIAL NUMBER OF COMPRESSOR

Section 8 ILLUSTRATIONS AND PARTS LIST

8.17 SUMP AND PARTS- 300-350HP/ 224-261KW

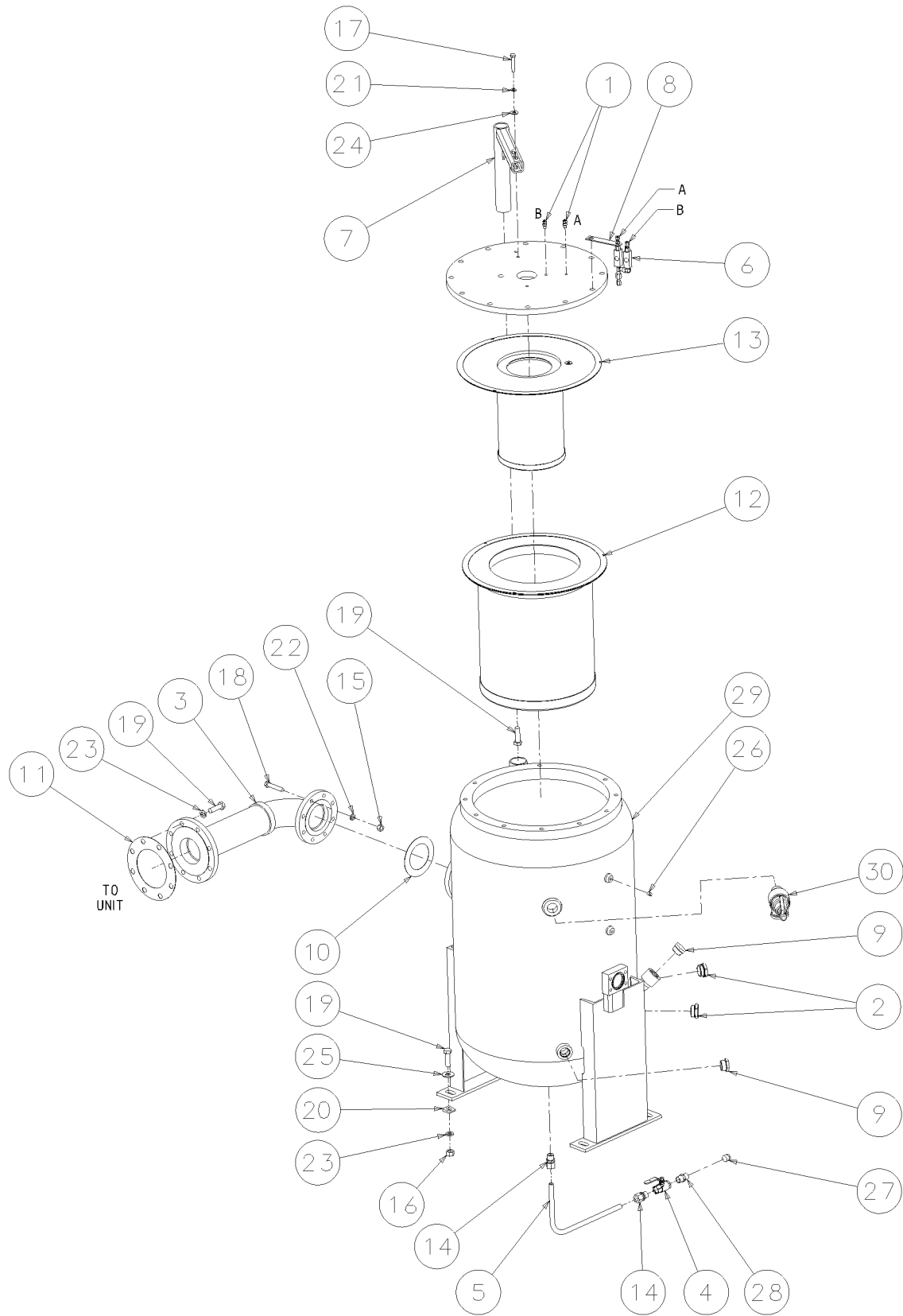

Section 8

ILLUSTRATIONS AND PARTS LIST

8.17 SUMP AND PARTS- 300-350HP/ 224-261KW

<i>key number</i>	<i>description</i>	<i>part number</i>	<i>quantity</i>
1	connector,flex 1/4t x 1/4p	020169	2
2	plug,sight glass 1-7/8" sae	02250097-611	2
3	joint, expansion ts32-200/350 4" vert tnk	02250120-730	1
4	valve, ball 3/4"sae x 3/4"npt	02250125-221	1
5	tube,3/4" sump drain	02250125-918	1
6	sub assembly,oil return/sightglass line	02250126-164	1
7	boom,lid lifting	02250127-249	1
8	support,oil return/sightglass line	02250128-598	1
9	plug,o-ring boss sae 1 1/4	040029	2
10	gasket, asa flange 150# 4"	240621-010	1
11	gasket, 6" 125# flg full face	242437-012	1
12	element, sep/pri (I)	250034-123	1
13	element, sep/sec (II)	250034-129	1
14	connector, tube str thd 3/4 x 1 1/16	811812-106	2
15	nut,hex pltd 5/8-11	825210-559	8
16	nut,hex pltd 3/4-10	825212-665	4
17	capscr, hex gr5 1/2-13 x 2 3/4	829108-275	2
18	capscr, hex gr5 5/8-11 x 3 1/4	829110-325	8
19	capscr, hex gr5 3/4-10 x 2 1/2	829112-250	13
20	washer, bevel 3/4	837012-150	2
21	washer, spr lock reg pltd 1/2	837808-125	2
22	washer, spr lock reg pltd 5/8	837810-156	
23	washer, spr lock reg pltd 3/4	837812-188	12
24	washer, pl-b reg pltd 1/2	838208-112	2
25	washer, pl-b reg pltd 3/4	838212-112	6
26	plug, pipe 1/4" 3000# stl plt	866900-010	1
27	plug, pipe 3/4" 3000# stl plt	866900-030	1
28	nipple,pipe-hx pltd 3/4 x 3/4	868512-075	1
29	tank, oil separator 30"dia (II)	-	1
30	valve, relief 1-1/2" 1950cfm viton s (II)	-	1

(I) For maintenance on separator elements, order (primary) replacement element no. 250034-124, and (secondary) replacment element no. 250034-130.

(II) This item may vary with machine. Consult factory with machine serial number.

PLEASE NOTE: WHEN ORDERING PARTS, INDICATE SERIAL NUMBER OF COMPRESSOR

Section 8 ILLUSTRATIONS AND PARTS LIST

8.18 SULLICON CONTROL

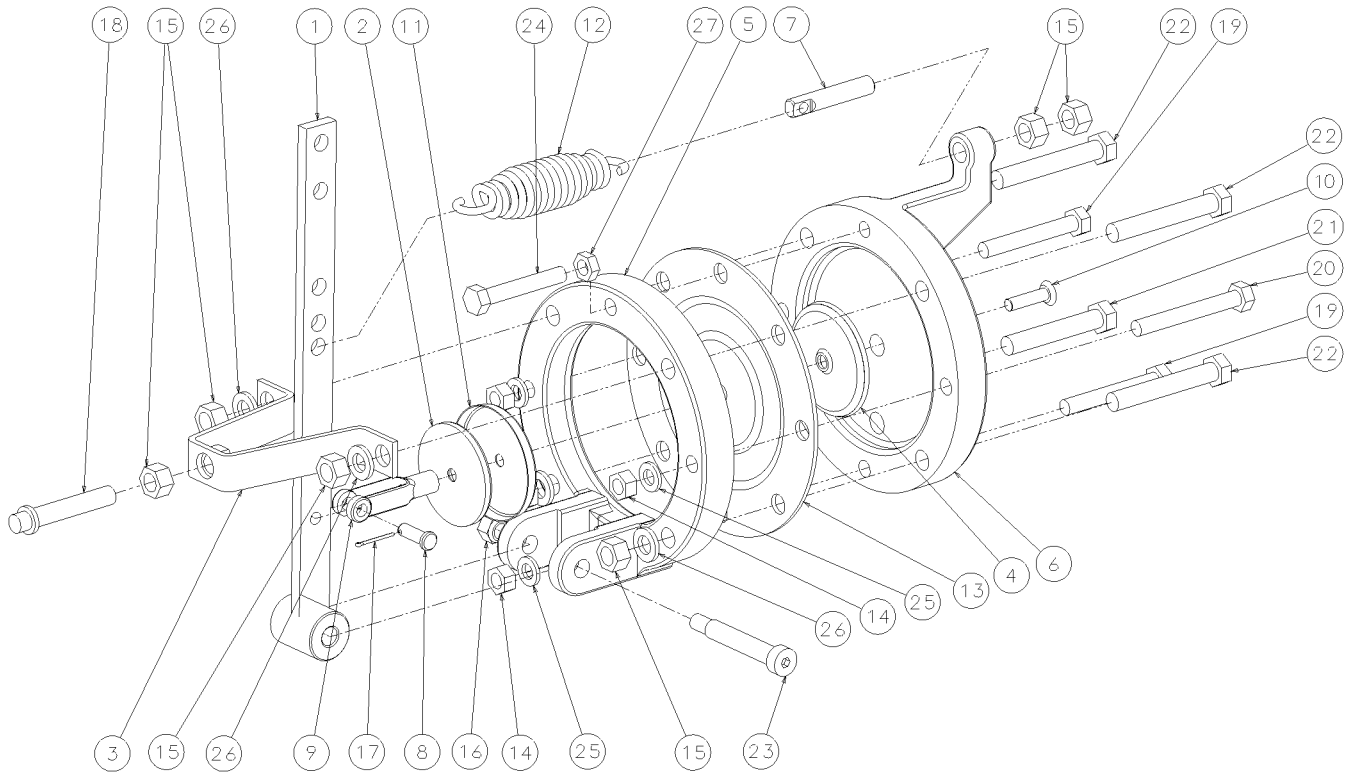

Section 8 ILLUSTRATIONS AND PARTS LIST

8.18 SULLICON CONTROL

<i>key number</i>	<i>description</i>	<i>part number</i>	<i>quantity</i>
1	lever, control Sullicon	011084	1
2	plunger	020094	1
3	stop, control	020864	1
4	washer, back-up (I)	021172	1
5	body,control	021635	1
6	cover, control	021654	1
7	bolt,adj sullicon spring yellow zinc	02250112-184	1
8	pin,yoke 1/4"	040065	1
9	rod-end, yoke	040138	1
10	screw, flathead countersunk (I)	041264	1
11	cup seal (I)	042538	1
12	spring, control light	250006-526	1
13	diaphragm, external (I)	250020-028	1
14	nut,hex pltd 5/16-18	825205-273	3
15	nut,hex pltd 3/8-16	825206-337	7
16	nut,hex locking 5/16-18	825505-166	1
17	pin,cotter ep-sc 1/16 x 3/4	827101-075	1
18	capscrew, ferry head hd 3/8-16 x 2	828406-200	1
19	capscr, hex gr5 5/16-18 x 2 1/4	829105-225	2
20	capscr, hex gr5 5/16-18 x 2 1/2	829105-250	1
21	capscr, hex gr5 3/8-16 x 2 1/4	829106-225	1
22	capscr, hex gr5 3/8-16 x 2 1/2	829106-250	3
23	screw, shoulder 3/8 x 2	830506-200	1
24	screw, mach-hex 5/16-24 x 2	831105-200	1
25	washer, spr lock reg pltd 5/16	837805-078	3
26	washer, spr lock reg pltd 3/8	837806-094	5
27	nut, hex jam rh pltd 5/16-24	868205-195	1

(I) This part is included in Sullicon repair kit no. 250020-353. For maintenance, order repair kit no. 250020-353.

PLEASE NOTE: WHEN ORDERING PARTS, INDICATE SERIAL NUMBER OF COMPRESSOR

Section 8 ILLUSTRATIONS AND PARTS LIST

8.19 COMPRESSOR ACTUATOR

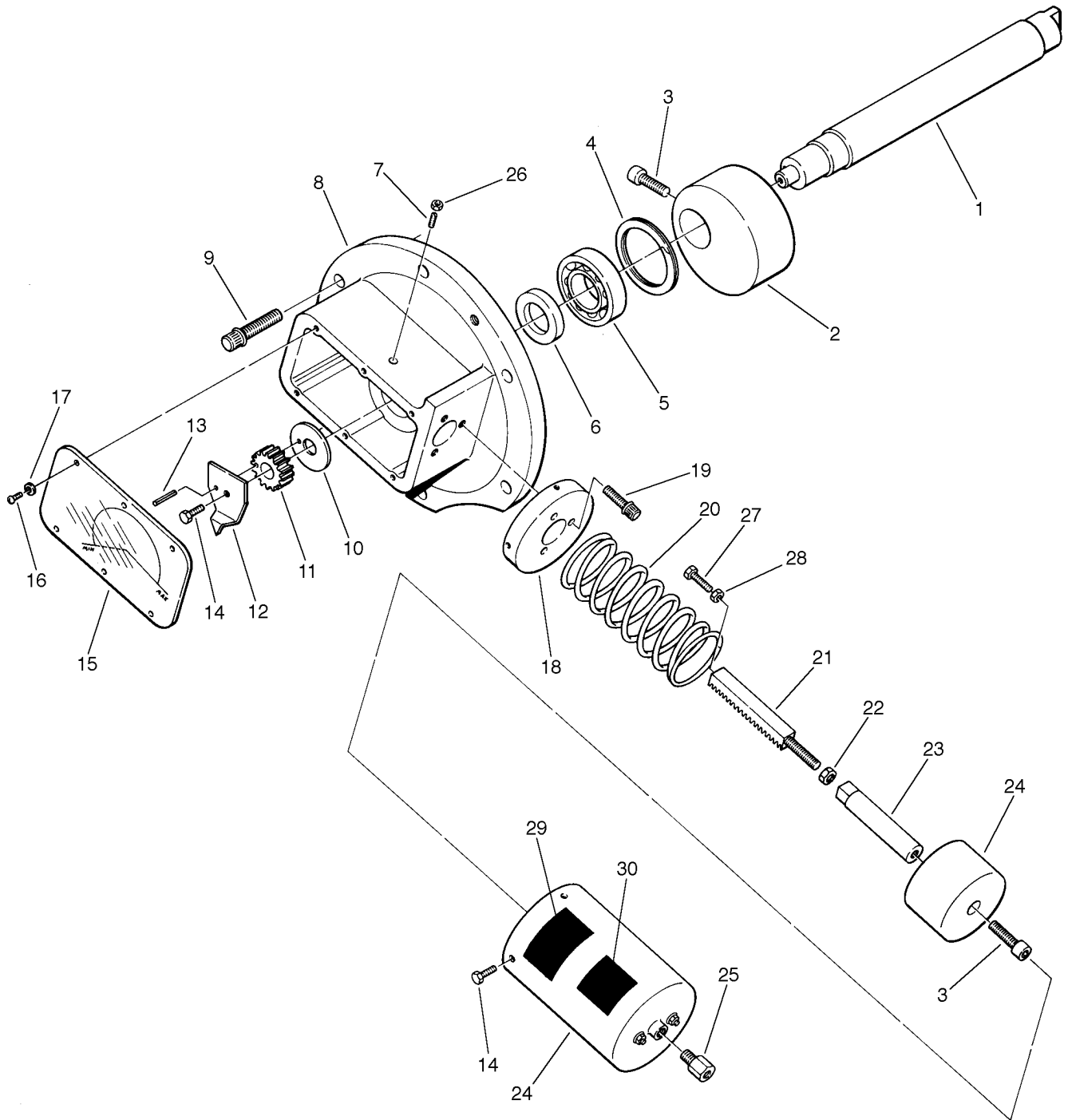

Section 8 ILLUSTRATIONS AND PARTS LIST

8.19 COMPRESSOR ACTUATOR

<i>key number</i>	<i>description</i>	<i>part number</i>	<i>quantity</i>
1	shaft, valve - direct	250030-981	1
	•shaft, valve - geared	250030-982	1
2	valve, weight counterbalance	250016-193	1
3	capscrew, socket 3/8"-16 x 1"	828906-100	2
4	ring, retaining	499068-005	1
5	bearing, ball	499002-207	1
6	seal, lip	250016-200	1
7	screw, set 1/2"-13 x 1.62 br	250024-465	1
8	adapter, air cylinder	250016-182	1
9	capscrew, ferry head 1/2"-13 x 1 1/2"	828408-150	6
10	guide, rack	250016-199	1
11	gear, pinion	250016-196	1
12	indicator, actuator	250030-983	1
13	pin, roll unfinished 1/4"x 1"	827404-100	1
14	capscrew, hex head gr8 1/4"-20 x 1/2"	828204-050	4
15	cover, adapter	250016-195	1
16	washer, regular #8	838201-045	6
17	screw, machine rod #8-32 x 1/2"	831601-050	6
18	mount, air cylinder	250016-188	1
19	capscrew, ferry head 1/2"-18 x 1 1/4"	828405-125	3
20	spring, seal 2 1/4"	250016-394	1
21	rack, gear	250016-197	1
22	nut, hex jam 3/8"-16	824906-227	1
23	shaft, air cylinder	250016-194	1
24	cylinder, air (I)	250016-183	1
25	orifice, .062 x .25m x .25f	028831	1
26	nut, hex unfinished 1/2"-13	824208-448	1
27	screw, machine hex 1/4"-20 x 1 3/4"	830104-175	1
28	nut, hex jam 1/4"-20	824904-164	1
29	decal, warning actuator	250029-836	1
30	decal, actuator valve positioning	250029-784	1

(I) For maintenance on air cylinder no. 250016-183, order diaphragm repair kit no. 608311-001.

PLEASE NOTE: WHEN ORDERING PARTS, INDICATE SERIAL NUMBER OF COMPRESSOR

Section 8 ILLUSTRATIONS AND PARTS LIST

8.20 MOISTURE DRAIN SEPARATOR

AC ORIENTATION

TO MOISTURE
SEPARATOR

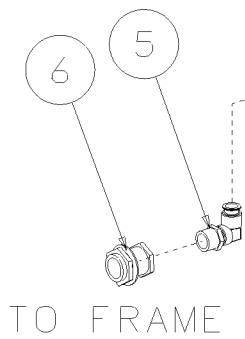
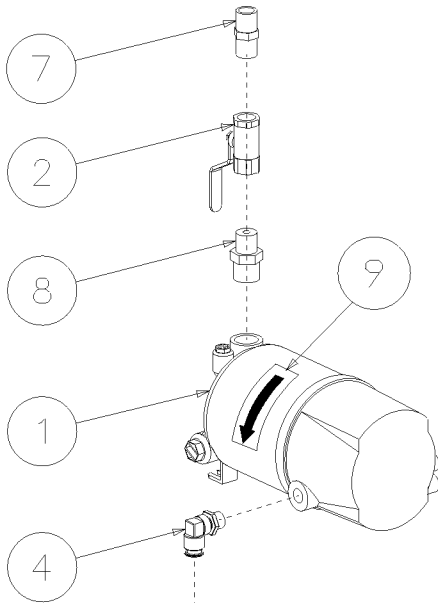

WC ORIENTATION

TO MOISTURE
SEPARATOR

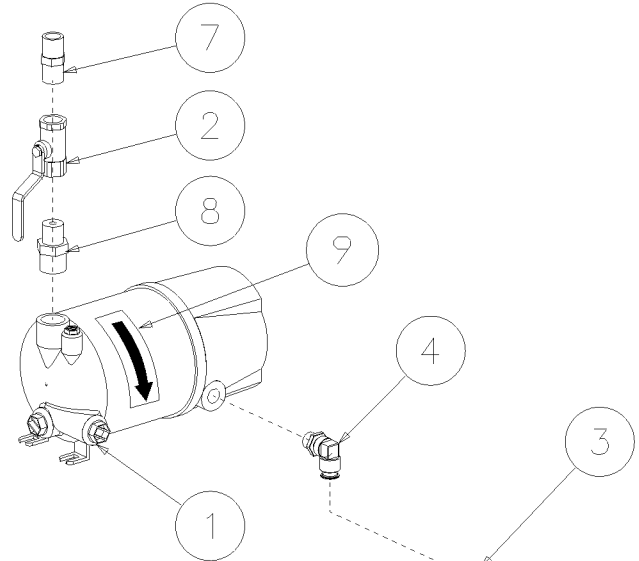

TO WATER IN
BRACKET

Section 8
ILLUSTRATIONS AND PARTS LIST

8.20 MOISTURE DRAIN SEPARATOR

<i>key number</i>	<i>description</i>	<i>part number</i>	<i>quantity</i>
1	drain,electric condensate - scd300	02250130-866	2
2	valve,ball 1/2"npt	047117	2
3	connector,tube-strt 1/2"mnpt x 1/2"tube	250024-695	1
4	connector, tube-el 3/8"npt x 1/2"tube	250024-713	2
5	connector, tube-el 1/2"npt x 1/2"tube	250024-714	1
6	bulkhead, pipe 1/2" npt	841500-008	1
7	nipple,pipe-hx pltd 1/2 x 1/2	868508-050	2
8	nipple,pipe-hx pltd 3/4 x 1/2	868512-050	2
9	decal, water drain	250022-810	1

PLEASE NOTE: WHEN ORDERING PARTS, INDICATE SERIAL NUMBER OF COMPRESSOR

Section 8 ILLUSTRATIONS AND PARTS LIST

8.21 PNEUMATIC CONTROLS

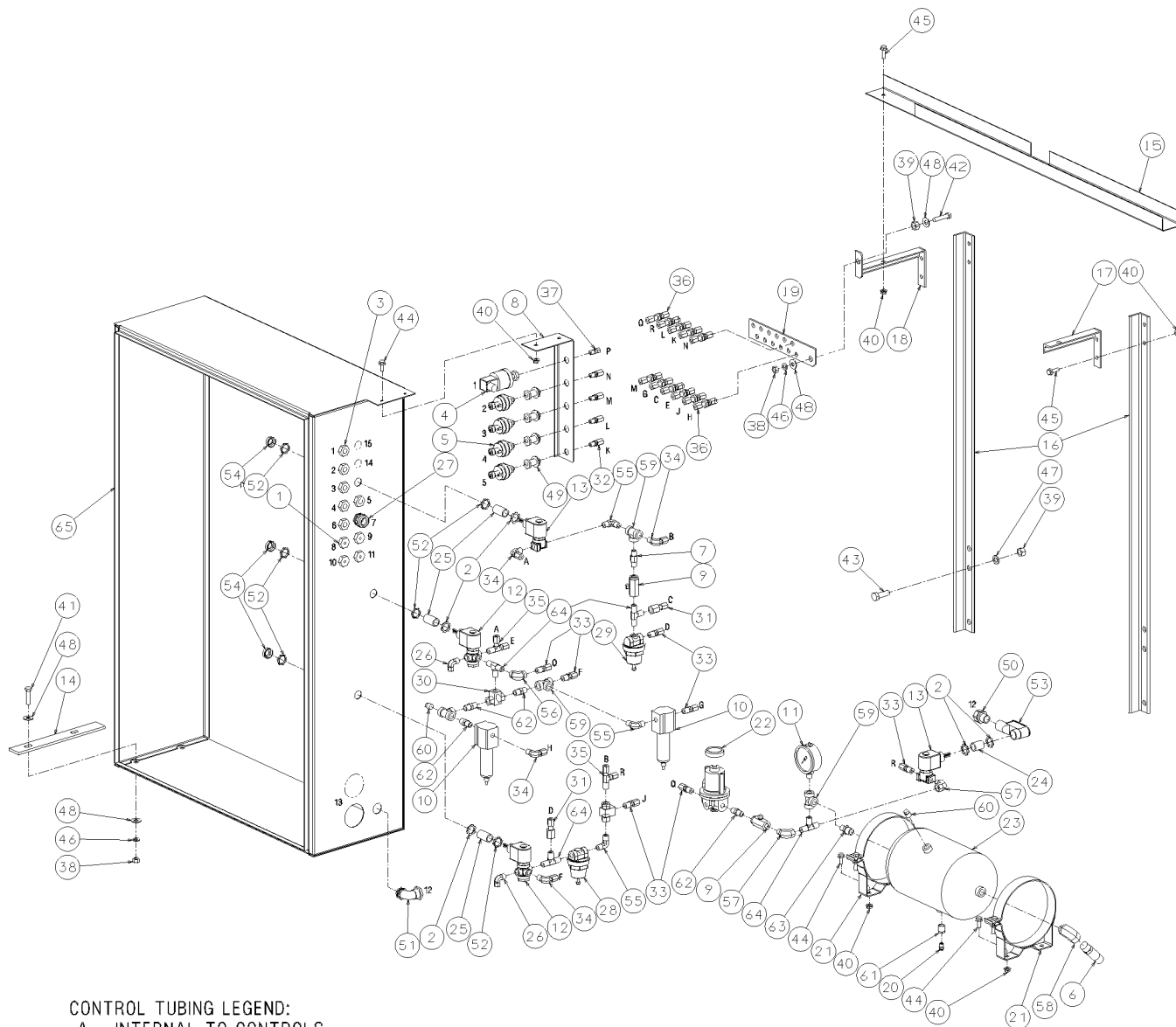

CONTROL TUBING LEGEND:

- A - INTERNAL TO CONTROLS
- B - INTERNAL TO CONTROLS
- C - SPIRAL VALVE
- D - INTERNAL TO CONTROLS
- E - BLOWDOWN VALVE
- F - INTERNAL TO CONTROLS
- G - MINIMUM PRESSURE VALVE
- H - DRY AIR/SUMP TANK LID PRESSURE
- J - SULLICON CONTROLLER OR PRESSURE REGULATING VALVE(>125PSIG)
- K - HIGH OIL PRESSURE-OIL FILTER DIFFERENTIAL
- L - LOW OIL PRESSURE-OIL FILTER DIFFERENTIAL
- M - MOISTURE SEPARATOR OUT
- N - HIGH SUMP/WET SIDE OIL SEPARATOR
- P - INLET AIR FILTER
- Q - CLOSED INLET ASSEMBLY-SOLENOID VALVE
- R - CLOSED INLET ASSEMBLY-CHECK VALVE OR PRESSURE REGULATING VALVE(>125PSIG)

ELECTRICAL LEGEND:

- 1 - INLET FILTER VACUUM SWITCH
- 2 - PRESSURE TRANSDUCER: P1
- 3 - PRESSURE TRANSDUCER: P2
- 4 - PRESSURE TRANSDUCER: P3
- 5 - PRESSURE TRANSDUCER: P4
- 6 - SCD MOISTURE SEPARATOR DRAIN
- 7 - AIR COOLED FAN MOTOR
(WATER COOLED WATER PRESSURE SWITCH)
- 8 - T1 RTD-UNIT DISCHARGE TEMPERATURE
- 9 - T2 RTD-DRY SIDE SUMP TEMPERATURE
- 10 - T3 RTD-UNIT INJECTION OIL TEMPERATURE
- 11 - T4 RTD-UNIT INTERSTAGE TEMPERATURE
- 12 - CLOSED INLET SOLENOID VALVE
- 13 - MAIN MOTOR WIRE CONNECTOR
(ADDITIONAL HOLE/CONNECTOR FOR Y-DELTA)
- 14 - INTEGRAL COOLER EES LOUVER CONTROL
- 15 - INTEGRAL COOLER EES TEMPERATURE SWITCH

Section 8

ILLUSTRATIONS AND PARTS LIST

8.21 PNEUMATIC CONTROLS

<i>key number</i>	<i>description</i>	<i>part number</i>	<i>quantity</i>
1	grip, cord n4 .125-.187 x 1/2"	02250071-279	4
2	locknut, n4 conduit sealing	02250071-362	5
3	grip, cord n4 .250-.375 x 1/2"	02250071-381	6
4	switch, vacuum 22"wc n4 6ft cable 5a	02250078-249	1
5	transducer, pressure 0-25psi 1-5vdc n4	02250078-933	4
6	valve, pressure relief 1/2"npt-150 psig	02250092-138	1
7	orifice, .031" x .25m x .25m nptf	02250101-191	1
8	support, bracket transducer mounting	02250110-132	1
9	valve, check 1/4"nptf viton seat	02250110-557	2
10	filter,control air 1/4"npt (I)	02250112-032	2
11	gage, air press 2 1/2" 0-200 psi	02250117-009	1
12	valve, solenoid 3wno 1/4 235# n4 (II)	02250125-657	2
13	valve, solenoid 2wnc 1/4 150# n4 (III)	02250125-679	2
14	support,str box ls20s ac	02250127-380	2
15	channel, ctl tubing supt	02250127-559	1
16	angle,support	02250133-550	2
17	bracket,support	02250133-551	1
18	bracket,supt	02250133-552	1
19	bracket, tubing manifold	02250133-564	1
20	valve, drain-self close 1/8npt	041111	1
21	band, mounting 7" dia	044285	2
22	regulator,press-1/4npt 2-150#	046556	1
23	reservoir, air 415 cu.in.	242221	1
24	nipple,conduit 1/2 x 1.125"	250007-168	1
25	nipple,conduit 1/2 x 1.5"	250007-169	3
26	elbow, 90 1/4t pls x 1/4 npt m	250018-430	2

(Continued on page 103)

(I) For maintenance on control filter no. 02250112-032, order repair kit no. 02250112-031.

(II) For maintenance on 3-way solenoid valve no. 02250125-657, order repair kit no. 02250125-829, and replacement coil no. 02250125-861.

(III) For maintenance on 2-way solenoid valve no. 02250125-679, order repair kit no. 02250125-824, and replacement coil no. 02250125-861.

PLEASE NOTE: WHEN ORDERING PARTS, INDICATE SERIAL NUMBER OF COMPRESSOR

Section 8 ILLUSTRATIONS AND PARTS LIST

8.21 PNEUMATIC CONTROLS

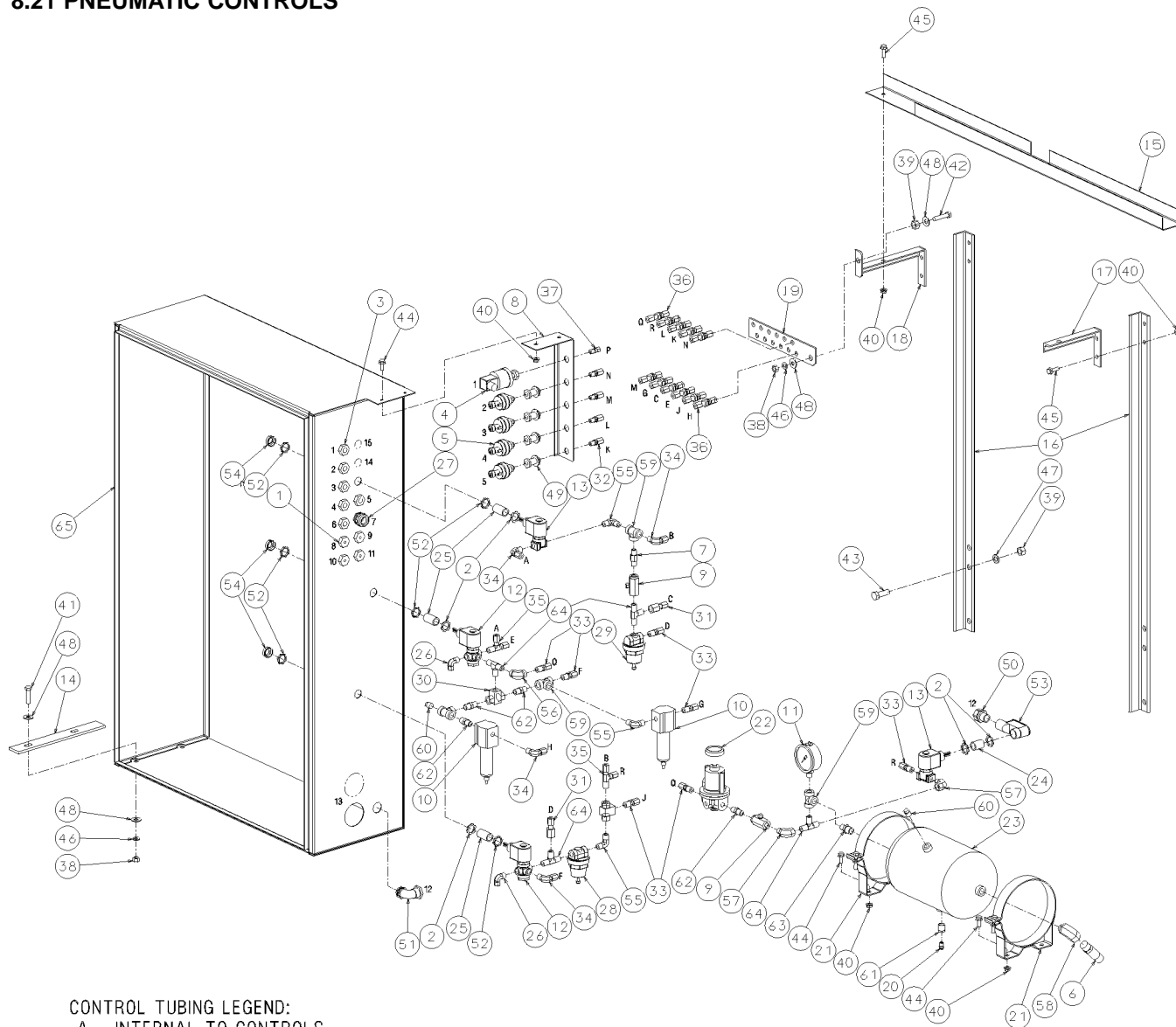

CONTROL TUBING LEGEND:

- A - INTERNAL TO CONTROLS
- B - INTERNAL TO CONTROLS
- C - SPIRAL VALVE
- D - INTERNAL TO CONTROLS
- E - BLOWDOWN VALVE
- F - INTERNAL TO CONTROLS
- G - MINIMUM PRESSURE VALVE
- H - DRY AIR/SUMP TANK LID PRESSURE
- J - SULLICON CONTROLLER OR PRESSURE REGULATING VALVE(>125PSIG)
- K - HIGH OIL PRESSURE-OIL FILTER DIFFERENTIAL
- L - LOW OIL PRESSURE-OIL FILTER DIFFERENTIAL
- M - MOISTURE SEPARATOR OUT
- N - HIGH SUMP/WET SIDE OIL SEPARATOR
- P - INLET AIR FILTER
- Q - CLOSED INLET ASSEMBLY-SOLENOID VALVE
- R - CLOSED INLET ASSEMBLY-CHECK VALVE OR PRESSURE REGULATING VALVE(>125PSIG)

ELECTRICAL LEGEND:

- 1 - INLET FILTER VACUUM SWITCH
- 2 - PRESSURE TRANSDUCER: P1
- 3 - PRESSURE TRANSDUCER: P2
- 4 - PRESSURE TRANSDUCER: P3
- 5 - PRESSURE TRANSDUCER: P4
- 6 - SCD MOISTURE SEPARATOR DRAIN
- 7 - AIR COOLED FAN MOTOR
(WATER COOLED WATER PRESSURE SWITCH)
- 8 - T1 RTD-UNIT DISCHARGE TEMPERATURE
- 9 - T2 RTD-DRY SIDE SUMP TEMPERATURE
- 10 - T3 RTD-UNIT INJECTION OIL TEMPERATURE
- 11 - T4 RTD-UNIT INTERSTAGE TEMPERATURE
- 12 - CLOSED INLET SOLENOID VALVE
- 13 - MAIN MOTOR WIRE CONNECTOR
(ADDITIONAL HOLE/CONNECTOR FOR Y-DELTA)
- 14 - INTEGRAL COOLER EES LOUVER CONTROL
- 15 - INTEGRAL COOLER EES TEMPERATURE SWITCH

Section 8

ILLUSTRATIONS AND PARTS LIST

8.21 PNEUMATIC CONTROLS (CONTINUED)

<i>key number</i>	<i>description</i>	<i>part number</i>	<i>quantity</i>
27	grip, cord so 12/4 st 1/2"	250018-495	1
28	valve, diff press reg 1/4" npt (IV)	406929	1
29	valve, pressure reg 100psi (V)	408275	1
30	valve, shuttle 1/4" npt (dbl chk)	408893	2
31	connector, tube-f 1/4 x 1/4	810104-025	2
32	connector, tube-m 1/4 x 1/8	810204-012	4
33	connector, tube-m 1/4 x 1/4	810204-025	7
34	elbow, tube 90 deg m 1/4 x 1/4	810504-025	4
35	tee, tube-male run 1/4 x 1/4	810904-025	2
36	union, tube bhd 1/4"	811104-025	11
37	connector, tube-m 1/4 x 1/8	813604-125	1
38	nut, hex pltd 3/8-16	825206-337	5
39	nut, hex pltd 1/2-13	825208-448	5
40	nut, hex f pltd 5/16-18	825305-283	12
41	capscr, hex gr5 3/8-16 x 1 1/2	829106-150	4
42	capscr, hex gr5 3/8-16 x 1 3/4	829106-175	1
43	capscr, hex gr5 1/2-13 x 1 1/2	829108-150	4
44	screw, hex ser washer 5/16-18 x 3/4	829705-075	6
45	screw, hex ser washer 5/16-18 x 1	829705-100	6
46	washer, spr lock reg pltd 3/8	837806-094	5
47	washer, spr lock reg pltd 1/2	837808-125	4
48	washer, pl-b reg pltd 3/8	838206-071	10
49	bulkhead, pipe 1/8" npt	841500-002	4
50	connector, straight lq-tite 1/2	846400-050	1
51	elbow, 90deg lq-tite 1/2	846600-050	1
52	locknut, conduit 1/2"	847200-050	6
53	elbow, entrance 1/2	847715-050	1
54	bushing, conduit plastic 1/2	848815-050	3

(Continued on [page 105](#))

(IV) For maintenance on differential pressure regulator valve no. 406929, order repair kit no. 041742.

(V) For maintenance on pressure regulator valve no. 408275, order repair kit no. 250028-693.

PLEASE NOTE: WHEN ORDERING PARTS, INDICATE SERIAL NUMBER OF COMPRESSOR

Section 8 ILLUSTRATIONS AND PARTS LIST

8.21 PNEUMATIC CONTROLS

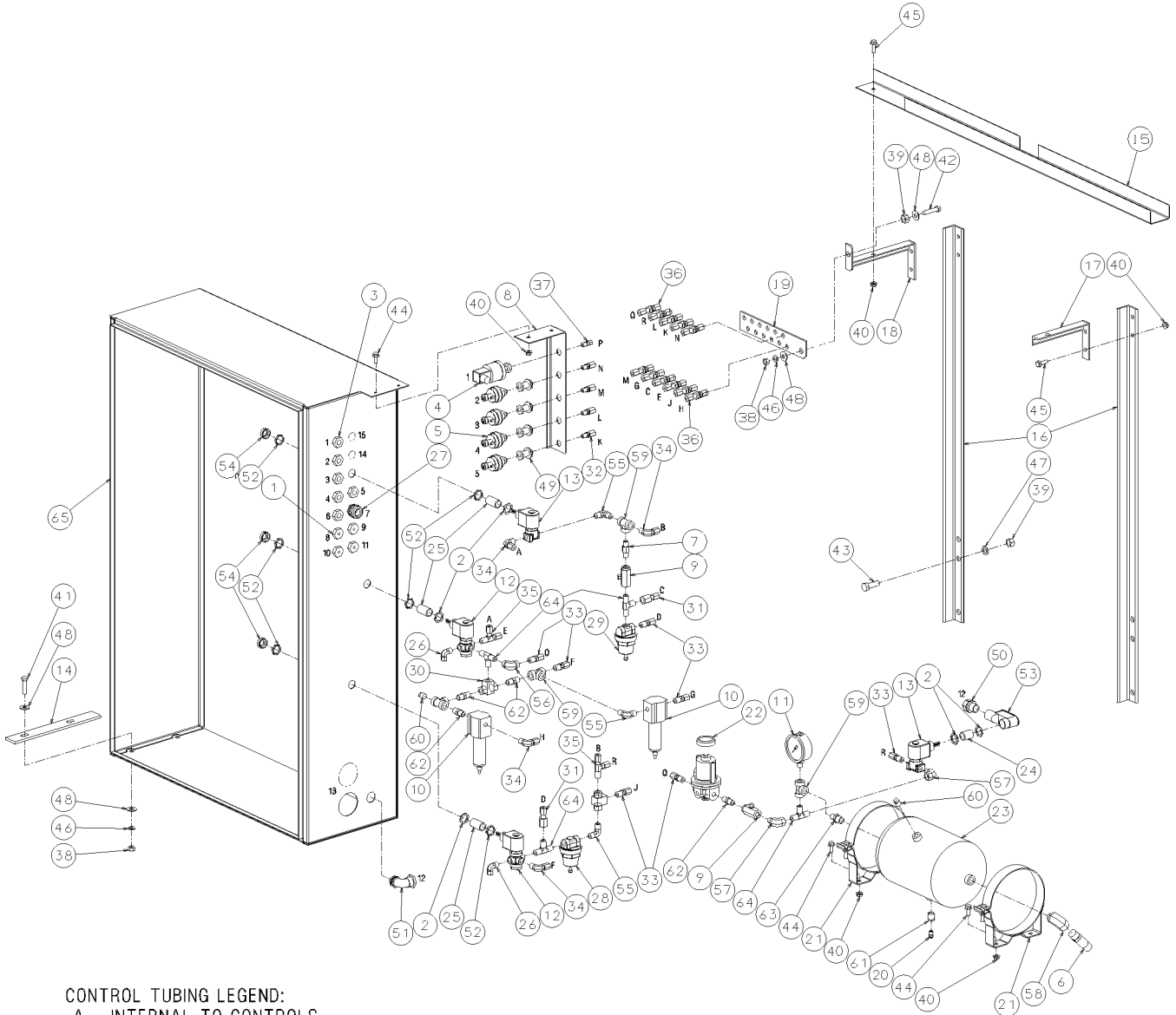

CONTROL TUBING LEGEND:

- A - INTERNAL TO CONTROLS
- B - INTERNAL TO CONTROLS
- C - SPIRAL VALVE
- D - INTERNAL TO CONTROLS
- E - BLOWDOWN VALVE
- F - INTERNAL TO CONTROLS
- G - MINIMUM PRESSURE VALVE
- H - DRY AIR/SUMP TANK LID PRESSURE
- J - SULLICON CONTROLLER OR PRESSURE REGULATING VALVE(>125PSIG)
- K - HIGH OIL PRESSURE-OIL FILTER DIFFERENTIAL
- L - LOW OIL PRESSURE-OIL FILTER DIFFERENTIAL
- M - MOISTURE SEPARATOR OUT
- N - HIGH SUMP/WET SIDE OIL SEPARATOR
- P - INLET AIR FILTER
- Q - CLOSED INLET ASSEMBLY-SOLENOID VALVE
- R - CLOSED INLET ASSEMBLY-CHECK VALVE OR PRESSURE REGULATING VALVE(>125PSIG)

ELECTRICAL LEGEND:

- 1 - INLET FILTER VACUUM SWITCH
- 2 - PRESSURE TRANSDUCER: P1
- 3 - PRESSURE TRANSDUCER: P2
- 4 - PRESSURE TRANSDUCER: P3
- 5 - PRESSURE TRANSDUCER: P4
- 6 - SCD MOISTURE SEPARATOR DRAIN
- 7 - AIR COOLED FAN MOTOR
(WATER COOLED WATER PRESSURE SWITCH)
- 8 - T1 RTD-UNIT DISCHARGE TEMPERATURE
- 9 - T2 RTD-DRY SIDE SUMP TEMPERATURE
- 10 - T3 RTD-UNIT INJECTION OIL TEMPERATURE
- 11 - T4 RTD-UNIT INTERSTAGE TEMPERATURE
- 12 - CLOSED INLET SOLENOID VALVE
- 13 - MAIN MOTOR WIRE CONNECTOR
(ADDITIONAL HOLE/CONNECTOR FOR Y-DELTA)
- 14 - INTEGRAL COOLER EES LOUVER CONTROL
- 15 - INTEGRAL COOLER EES TEMPERATURE SWITCH

Section 8

ILLUSTRATIONS AND PARTS LIST

8.21 PNEUMATIC CONTROLS (CONTINUED)

<i>key number</i>	<i>description</i>	<i>part number</i>	<i>quantity</i>
55	elbow, pipe-90m 1/4 x 1/4	860504-025	3
56	elbow, pipe 90f 1/4 x 1/4	860604-025	1
57	elbow, pipe 90m/f 1/4 x 1/4	860704-025	2
58	elbow, pipe 90m/f 3/8 x 1/2	860706-050	1
59	tee, pipe 150# plt 1/4	866815-010	4
60	plug, pipe 1/4" 3000# stl plt	866900-010	2
61	bushing,red pltd 3/8 x 1/8	867101-005	1
62	nipple,pipe-hx pltd 1/4 x 1/4	868504-025	4
63	nipple,pipe-hx pltd 3/8 x 1/4	868506-025	1
64	tee,male pipe brass 1/4	869825-025	4
65	starter,assy ts32a (VI)	-	1

(VI) This item may vary with machine. Consult factory with machine serial number.

PLEASE NOTE: WHEN ORDERING PARTS, INDICATE SERIAL NUMBER OF COMPRESSOR

Section 8

ILLUSTRATIONS AND PARTS LIST

8.22 CONTROL BOX- SOLID STATE

<i>key number</i>	<i>description</i>	<i>part number</i>	<i>quantity</i>
1	enclosure	02550108-859	1
2	door	02550109-465	1
3	bezel	02250089-302	1
4	beze; gasket	02550090-872	1
5	I/O module	02250119-331	1
6	display module	02250119-330	1
7	display gasket	02250048-822	2
8	primary fuse 305 amp	250026-648	1
9	secondary fuse 5 amp	250019-751	1
10	univ. 250 va trans	02250083-189	1
11	power supply 24v	0250120-644	1
12	relay	d45496	1
13	relay base	46467	1
14	ground bus	02550110-334	1
15	ground bar	02550101-721	1
16	240A IT starter	02250122-042	1
17	304A IT starter	02250120-789	-
18	360A IT starter	02250120-792	-
19	420A IT starter	02250122-043	-
20	500A IT starter	02250122-044	-
21	650A IT starter	02250120-645	-
22	850A IT starter	02250122-046	-
23	display label	02250130-344	1
24	E-stop decal	02550086-259	1
25	E-stop operator	02550085-504	1
26	contact block	250027-125	1
27	plate	02550086-265	1

PLEASE NOTE: WHEN ORDERING PARTS, INDICATE SERIAL NUMBER OF COMPRESSOR

Section 8

ILLUSTRATIONS AND PARTS LIST

8.23 CONTROL BOX- FULL VOLTAGE

<i>key number</i>	<i>description</i>	<i>part number</i>	<i>quantity</i>
1	enclosure	02550108-859	1
2	door	02550109-465	1
3	bezel	02250129-958	1
4	bezel gasket	02550090-872	1
5	I/O module	02550119-331	1
6	transformer 24v	02250135-283	1
7	primary fuse 3.5 amp	250026-648	2
8	secondary fuse 5 amp	250019-751	1
9	univ. 350 va trans	02250083-189	1
10	univ. 500 va trans	02250083-192	-
11	primary fuse 4 amp	250026-649	-
12	secondary fuse 6 a	250019-762	-
13	ground bus	02550110-334	1
14	ground bar	02550101-721	1
15	display module	02550119-330	1
16	display label	02550130-344	1
17	starter9 size 5	250038-284	1
18	starter9 size 5dp	02250113-513	-
19	starter9 size 6	250038-285	-
20	display module gasket	02250048-822	2
21	E-stop operator	02250085-504	1
22	contact block I-NC	250027-125	1
23	E-stop decal	02250086-259	1
24	plate	02250086-265	1

PLEASE NOTE: WHEN ORDERING PARTS, INDICATE SERIAL NUMBER OF COMPRESSOR

Section 8 ILLUSTRATIONS AND PARTS LIST

8.24 CONTROL BOX- WYE-DELTA

102 WIRE IS WHITE
 ALL OTHER 100 WIRES ARE RED
 ALL 200 E WIRES ARE DARK BLUE
 GROUND WIRES ARE GREEN WITH YELLOW TRACER
 DO NOT TIE WRAP 6-WIRE CABLE TO BOX OR DOOR.
 SEAL ENCLOSURE NEMA 4

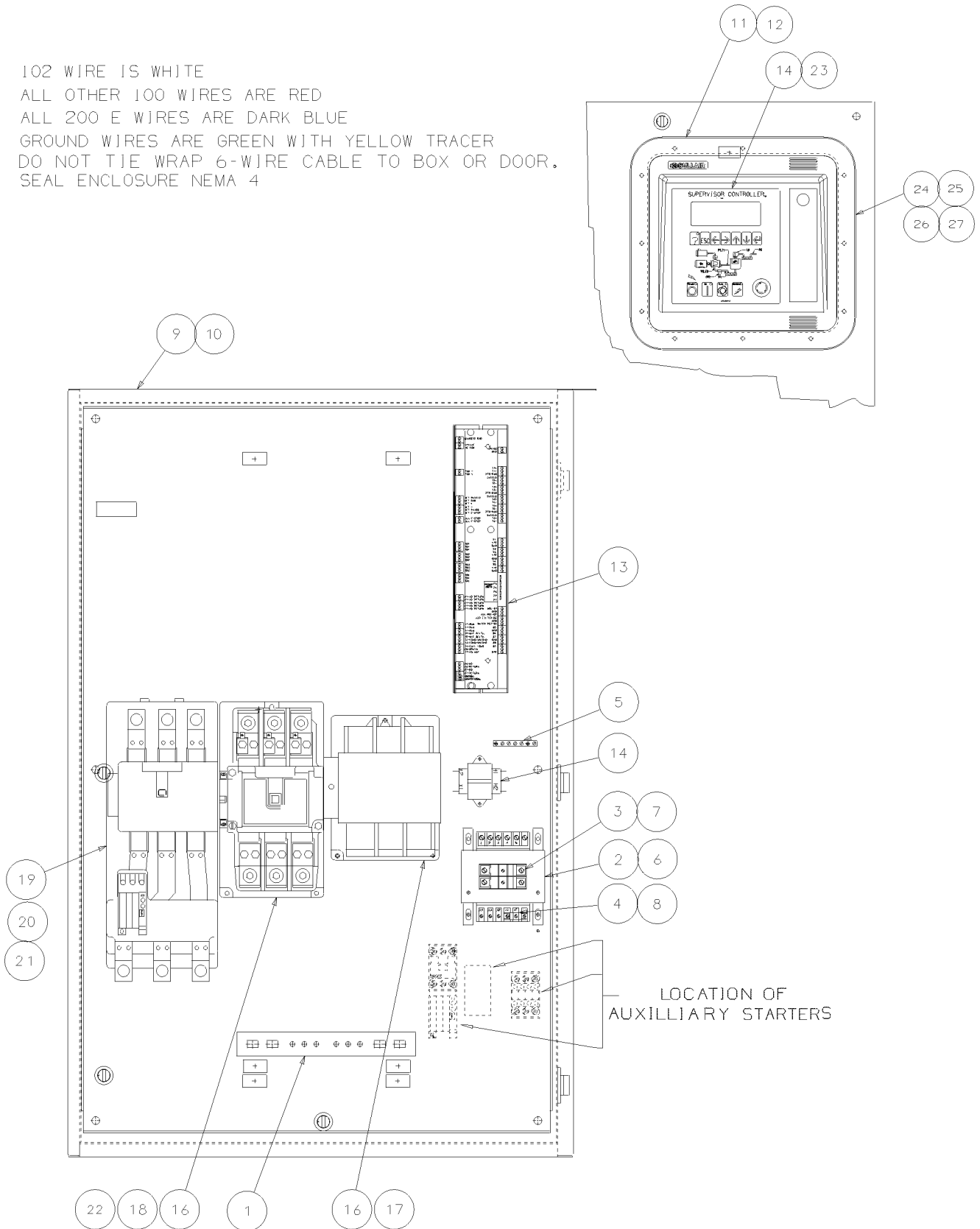

02250122-516R4

Section 8

ILLUSTRATIONS AND PARTS LIST

8.24 CONTROL BOX- WYE-DELTA

<i>key number</i>	<i>description</i>	<i>part number</i>	<i>quantity</i>
1	ground bus	02550110-334	
2	univ. 250 va trans	02250083-188	-
3	primary fuse 2.5 amp	250026-646	-
4	secondary fuse 3 amp	250019-758	-
5	ground bar	02550101-721	1
6	univ. 350 va trans	02250083-190	1
7	primary fuse 3.5 amp	250026-648	2
8	secondary fuse 5 amp	250019-761	1
9	door	02550109-465	1
10	enclosure	02550108-859	1
11	bezel	02250089-302	1
12	bezel gasket	02550090-872	1
13	I/O module	02550119-331	1
14	display module	02550119-330	1
15	transformer 24v	02250135-283	1
16	size 5 contactor	02250083-824	1
17	size 4 contactor	02550083-823	1
18	size 5dp contactor	02550113-514	-
19	size 5dp starter	02550113-513	-
20	starter size 5	250038-284	1
21	starter size n	250038-283	-
22	rev contactors size n	250041-589	-
23	display label	02550130-344	1
24	E-stop operator	02550085-504	1
25	contact block	250027-125	1
26	plate	02550086-265	1
27	E-stop decal	02550086-259	1

PLEASE NOTE: WHEN ORDERING PARTS, INDICATE SERIAL NUMBER OF COMPRESSOR

Section 8 ILLUSTRATIONS AND PARTS LIST

8.25 ENCLOSURE- AIR-COOLED 200-250HP/ 149-186KW

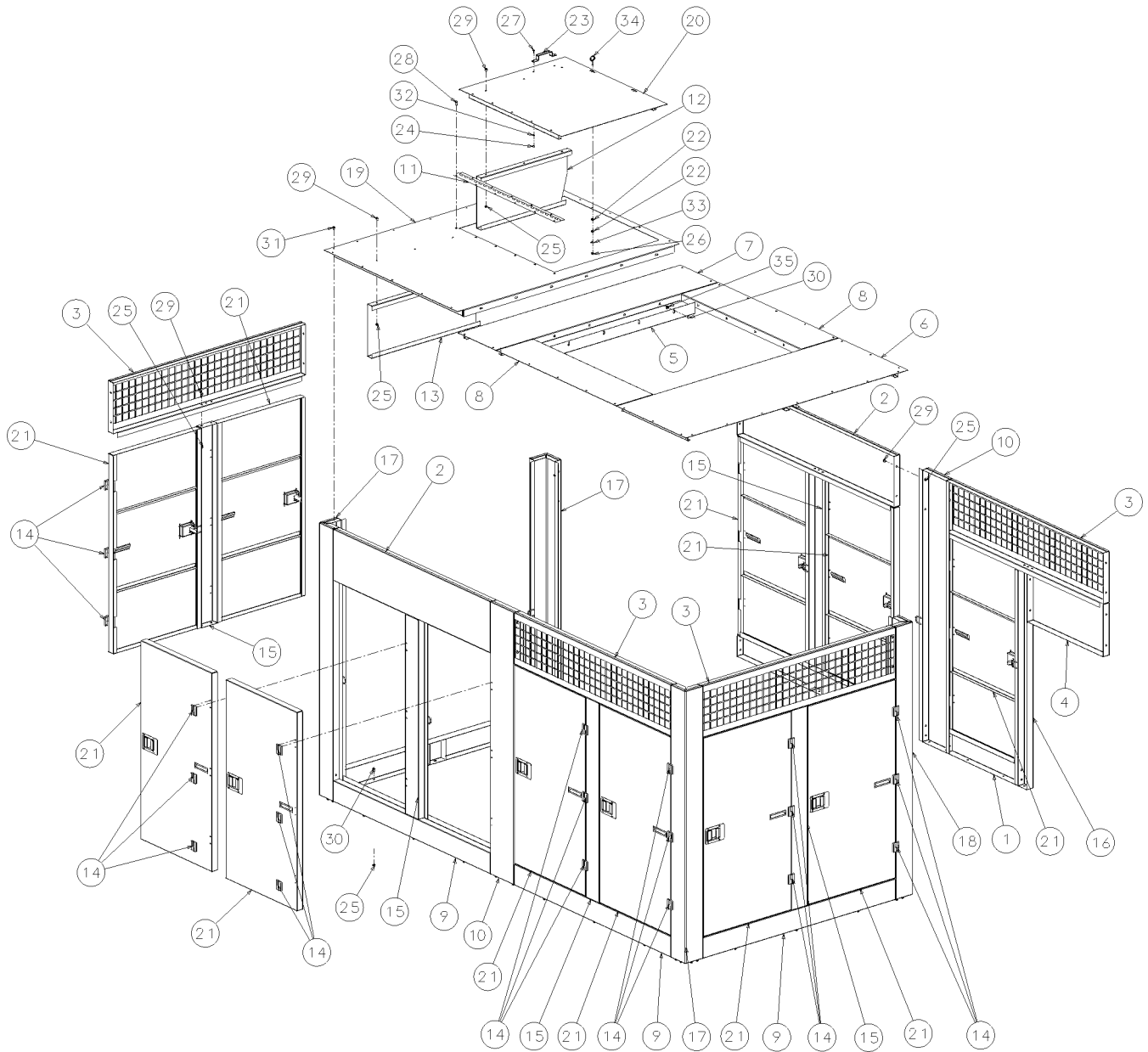

Section 8 ILLUSTRATIONS AND PARTS LIST

8.25 ENCLOSURE- AIR-COOLED 200-250HP/ 149-186KW

<i>key number</i>	<i>description</i>	<i>part number</i>	<i>quantity</i>
1	panel,sill short ts32a	02250124-938	1
2	panel,header side ts32a	02250124-939	2
3	panel,header end ts32a	02250124-940	4
4	panel,header 60" str ts32 encl	02250124-942	1
5	angle, roof seal ts32a-200/250ac	02250125-070	4
6	panel, roof end ts32a-200/250ac	02250126-923	1
7	panel, roof mid ts32a-200/250ac	02250126-924	1
8	panel, roof side ts32a-200/250ac	02250126-925	2
9	panel, sill ts32a	02250129-475	5
10	support, center ts32a	02250129-478	2
11	hinge, separator access door	02250129-761	1
12	panel,baffle sep access door ts32a	02250129-762	1
13	panel,baffle unit end ts32a	02250129-838	1
14	hinge, 180deg. screw-on lift-off rh	02250129-863	33
15	support, canopy ts32a	02250130-219	5
16	support, starter side ts32a	02250130-221	1
17	support, corner ts32a	02250130-222	3
18	support, corner spcl ts32a	02250130-223	1
19	panel, roof sump end ts32a	02250130-224	1
20	cover, separator access	02250130-226	1
21	panel, access assy 30" x 57"	02250130-227	11
22	grommet,rubber	040125	4
23	handle, canopy	042262	1
24	nut,hex pltd 1/4-20	825104-226	2
25	nut,hex f pltd 5/16-18	825305-283	13
26	nut,hex locking 5/16-18	825505-166	2
27	capscr, hex gr8 1/4-20 x 3/4	827904-075	2
28	capscr, hex gr5 5/16-18 x 3/4	829105-075	6
29	screw, hex ser washer 5/16-18 x 1/2	829705-050	94
30	screw, hex ser washer 5/16-18 x 3/4	829705-075	60
31	screw, self-drill 1/4 x 1/2	834504-050	44

(Contiued on [page 115](#))

PLEASE NOTE: WHEN ORDERING PARTS, INDICATE SERIAL NUMBER OF COMPRESSOR

Section 8 ILLUSTRATIONS AND PARTS LIST

8.25 ENCLOSURE- AIR-COOLED 200-250HP/ 149-186KW

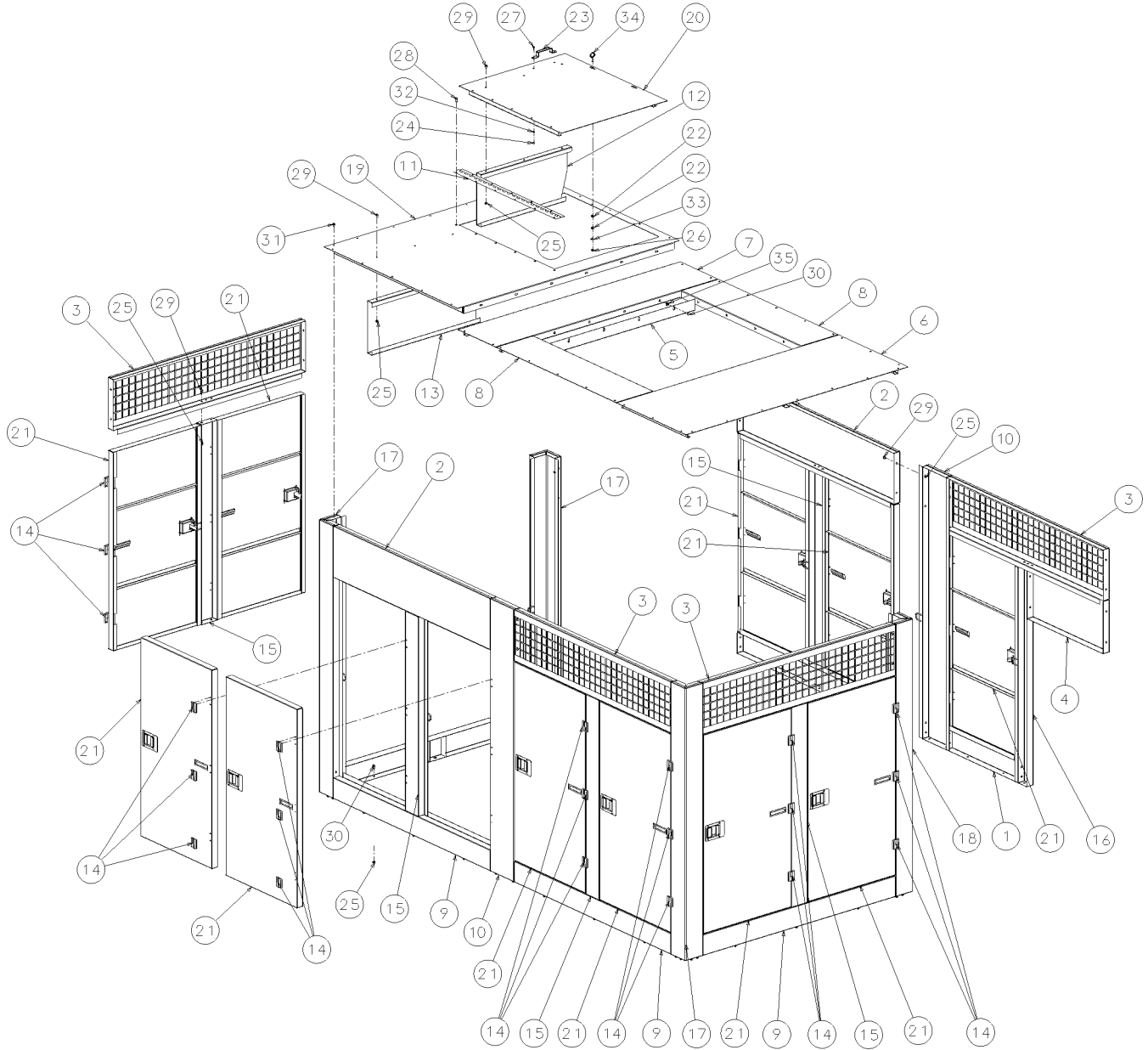

Section 8

ILLUSTRATIONS AND PARTS LIST

8.25 ENCLOSURE- AIR-COOLED 200-250HP/ 149-186KW (CONTINUED)

<i>key number</i>	<i>description</i>	<i>part number</i>	<i>quantity</i>
32	washer, spr lock reg pltd 1/4	837804-062	2
33	washer, pl-b reg pltd 5/16	838205-071	2
34	eyebolt,5/16-18 x 1 1/8" pltd	839105-112	2
35	nut,retainer 5/16-18 .092	861405-092	16

PLEASE NOTE: WHEN ORDERING PARTS, INDICATE SERIAL NUMBER OF COMPRESSOR

Section 8 ILLUSTRATIONS AND PARTS LIST

8.26 ENCLOSURE- AIR-COOLED 300-350HP/ 224-261KW

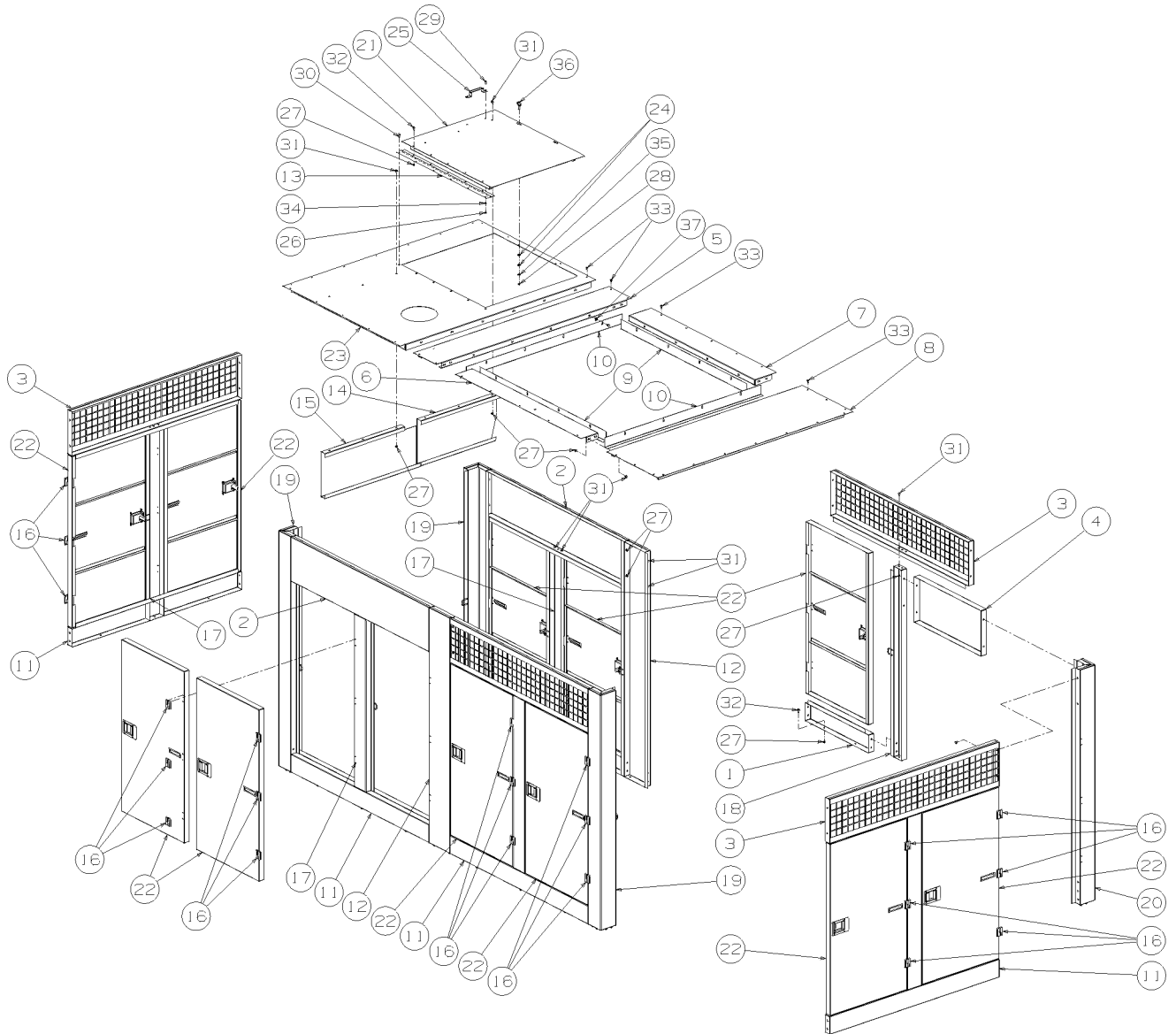

Section 8 ILLUSTRATIONS AND PARTS LIST

8.26 ENCLOSURE- AIR-COOLED 300-350HP/ 224-261KW

<i>key number</i>	<i>description</i>	<i>part number</i>	<i>quantity</i>
1	panel,sill short ts32a	02250124-938	1
2	panel,header side ts32a	02250124-939	2
3	panel,header end ts32a	02250124-940	4
4	panel,header 60" str ts32 encl	02250124-942	1
5	panel, roof center ts32a-300/350ac	02250127-099	1
6	panel, roof motor side ts32a-300/350ac	02250127-100	1
7	panel, roof starter side ts32a-300/350	02250127-101	1
8	panel, roof end ts32a-300/350ac	02250127-102	1
9	angle, roof seal ts32a-300/350ac	02250127-103	2
10	angle, roof seal ts32a-300/350ac	02250127-104	2
11	panel, sill ts32a	02250129-475	5
12	support, center ts32a	02250129-478	2
13	hinge, separator access door	02250129-761	1
14	panel,baffle sep access door ts32a	02250129-762	1
15	panel,baffle unit end ts32a	02250129-838	1
16	hinge, 180deg. screw-on lift-off rh	02250129-863	33
17	support, canopy ts32a	02250130-219	5
18	support, starter side ts32a	02250130-221	1
19	support, corner ts32a	02250130-222	3
20	support, corner spcl ts32a	02250130-223	1
21	cover, separator access	02250130-226	1
22	panel, access assy 30" x 57"	02250130-227	11
23	roof,ts32-350 intclr rmtinl	02250133-148	1
24	grommet,rubber	040125	4
25	handle, canopy	042262	1
26	nut,hex pltd 1/4-20	825104-226	2
27	nut,hex f pltd 5/16-18	825305-283	13
28	nut,hex locking 5/16-18	825505-166	2
29	capscr, hex gr5 1/4-20 x 3/4	829104-075	2
30	capscr, hex gr5 5/16-18 x 3/4	829105-075	6
31	screw, hex ser washer 5/16-18 x 1/2	829705-050	94

(Continued on [page 119](#))

PLEASE NOTE: WHEN ORDERING PARTS, INDICATE SERIAL NUMBER OF COMPRESSOR

Section 8 ILLUSTRATIONS AND PARTS LIST

8.26 ENCLOSURE- AIR-COOLED 300-350HP/ 224-261KW

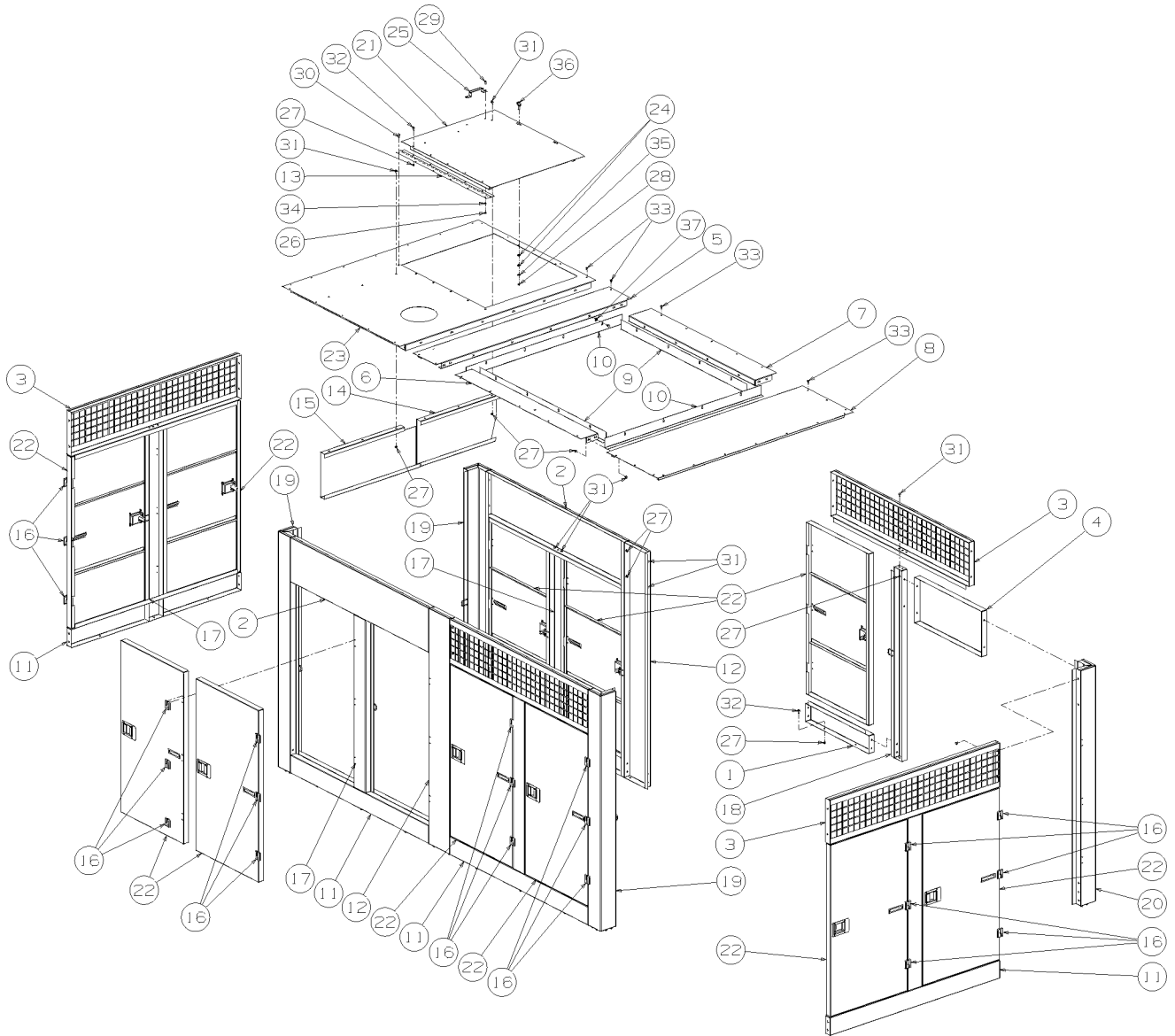

Section 8

ILLUSTRATIONS AND PARTS LIST

8.26 ENCLOSURE- AIR-COOLED 300-350HP/ 224-261KW (CONTINUED)

<i>key number</i>	<i>description</i>	<i>part number</i>	<i>quantity</i>
32	screw, hex ser washer 5/16-18 x 3/4	829705-075	60
33	screw, self-drill 1/4 x 1/2	834504-050	44
34	washer, spr lock reg pltd 1/4	837804-062	2
35	washer, pl-b reg pltd 5/16	838205-071	2
36	eyebolt,5/16-18 x 1 1/8" pltd	839105-112	2
37	nut,retainer 5/16-18 .092	861405-092	16

PLEASE NOTE: WHEN ORDERING PARTS, INDICATE SERIAL NUMBER OF COMPRESSOR

Section 8 ILLUSTRATIONS AND PARTS LIST

8.27 ENCLOSURE- WATER-COOLED 200-350HP/ 149-261KW

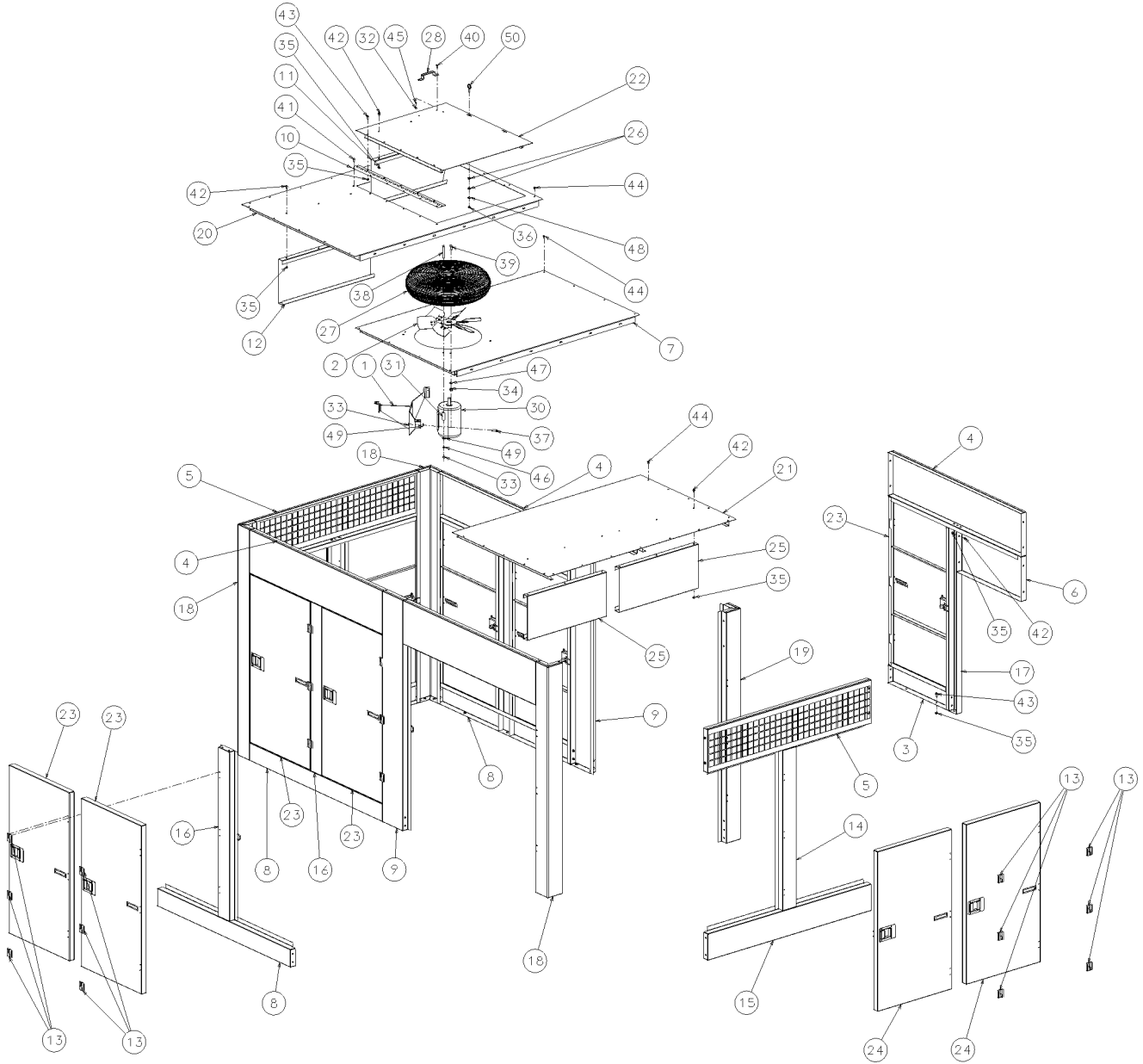

Section 8

ILLUSTRATIONS AND PARTS LIST

8.27 ENCLOSURE- WATER-COOLED 200-350HP/ 149-261KW

<i>key number</i>	<i>description</i>	<i>part number</i>	<i>quantity</i>
1	support, fan motor	014613	1
2	fan, blower 20"-30 deg 185q8f	02250107-474	1
3	panel,sill short ts32a	02250124-938	1
4	panel,header side ts32a	02250124-939	4
5	panel,header end ts32a	02250124-940	2
6	panel,header 60" str ts32 encl	02250124-942	1
7	panel, roof center ts32a-200/350 wc &	02250126-834	1
8	panel, sill ts32a	02250129-475	4
9	support, center ts32a	02250129-478	2
10	hinge, separator access door	02250129-761	1
11	panel,baffle sep access door ts32a	02250129-762	1
12	panel,baffle unit end ts32a	02250129-838	1
13	hinge, 180deg. screw-on lift-off rh	02250129-863	33
14	support, canopy spcl ts32a	02250129-995	1
15	panel,sill spcl ts32a-200/350 wc & rc	02250130-216	1
16	support, canopy ts32a	02250130-219	4
17	support, starter side ts32a	02250130-221	1
18	support, corner ts32a	02250130-222	3
19	support, corner spcl ts32a	02250130-223	1
20	panel, roof sump end ts32a	02250130-224	1
21	panel, roof mtr end ts32a-200/350 wc &	02250130-225	1
22	cover, separator access	02250130-226	1
23	panel, access assy 30" x 57"	02250130-227	9
24	panel, access assy 30" x 54"	02250130-228	2
25	panel,baffle mtr end ts32a-200/350wc	02250131-583	2
26	grommet,rubber	040125	4
27	guard, fan 24"	041765	1
28	handle, canopy	042262	1
29	clamp, speed tube 1/4"	043357	1
30	motor, .75hp 230/460v tefc	050288	1
31	spacer, fan support	227267	3
32	nut,hex pltd 1/4-20	825104-226	2

(Continued on [page 123](#))

PLEASE NOTE: WHEN ORDERING PARTS, INDICATE SERIAL NUMBER OF COMPRESSOR

Section 8 ILLUSTRATIONS AND PARTS LIST

8.27 ENCLOSURE- WATER-COOLED 200-350HP/ 149-261KW

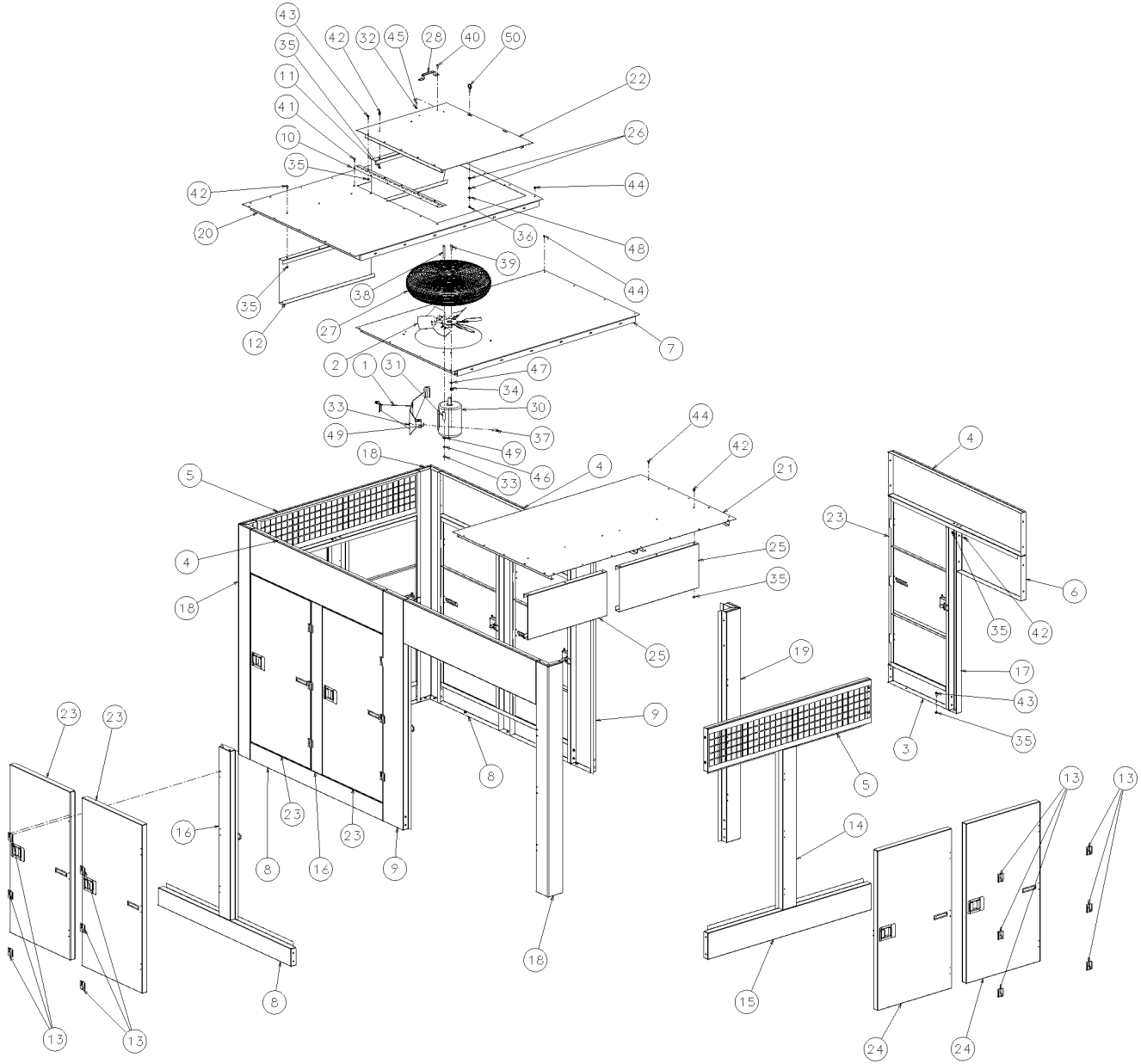

Section 8
ILLUSTRATIONS AND PARTS LIST

8.27 ENCLOSURE- WATER-COOLED 200-350HP/ 149-261KW (CONTINUED)

<i>key number</i>	<i>description</i>	<i>part number</i>	<i>quantity</i>
33	nut,hex pltd 3/8-16	825106-337	7
34	nut,hex pltd 1/2-13	825108-448	4
35	nut,hex f pltd 5/16-18	825305-283	14
36	nut,hex locking 5/16-18	825505-166	2
37	capscr, hex gr5 3/8-16 x 1 1/4	828606-125	4
38	capscr, hex gr5 3/8-16 x 4	828606-400	3
39	capscr, hex gr5 1/2-13 x 1	828608-100	4
40	capscr, hex gr5 1/4-20 x 3/4	829104-075	2
41	capscr, hex gr5 5/16-18 x 3/4	829105-075	6
42	screw, hex ser washer 5/16-18 x 1/2	829705-050	94
43	screw, hex ser washer 5/16-18 x 3/4	829705-075	44
44	screw, self-drill 1/4 x 1/2	834504-050	42
45	washer, spr lock reg pltd 1/4	837804-062	2
46	washer, spr lock reg pltd 3/8	837806-094	3
47	washer, spr lock reg pltd 1/2	837808-125	4
48	washer, pl-b reg pltd 5/16	838205-071	2
49	washer, pl-b reg pltd 3/8	838206-071	7
50	eyebolt,5/16-18 x 1 1/8" pltd	839105-112	2

PLEASE NOTE: WHEN ORDERING PARTS, INDICATE SERIAL NUMBER OF COMPRESSOR

Section 8 ILLUSTRATIONS AND PARTS LIST

8.28 DECALS

⚠ WARNING



Do not operate without fan guard in place.

40965 1

⚠ WARNING



Hot surfaces.

To avoid burns, keep hands and all parts of the body away.

2 407408

⚠ WARNING

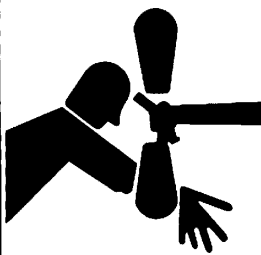

Disconnect all power at source, before attempting maintenance or adjustments.

49655

⚠ DANGER



Lethal shock hazard inside.

Disconnect all power at source, before opening or servicing.

4 48850

⚠ WARNING



Do not permit air from this equipment to contact food stuff except in full compliance with FDA Standard 21CFR178.3570, and all other applicable federal, state and local, codes, standards and regulations.

5 250003-144

⚠ WARNING



Cannister under spring pressure. When removing any screws on the canister, mechanical restraints must be used. Tool Kit #606174-001 is available from SULLAIR unit parts Division, Michigan City, IN

6 250029-836 REV. 01

⚠ WARNING

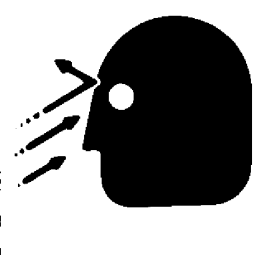

Do not remove caps, plugs, or other components when compressor is running or pressurized.

Stop compressor and relieve all internal pressure before doing so.

7 44385

⚠ DANGER



Death or serious injury can occur from inhaling compressed air without using proper safety equipment.

See OSHA standards on safety equipment.

8 250027-935



Section 8 ILLUSTRATIONS AND PARTS LIST

8.28 DECALS

<i>key number</i>	<i>description</i>	<i>part number</i>	<i>quantity</i>
1	sign, warning sever-fan port	049965	1
2	sign, warning hot surfaces	407408	1
3	sign, warning sever - fan	049855	2
4	sign, danger electrocution	049850	1
5	sign, warning "food grade" lube	250003-144	1
6	decal, warning actuator	250029-836	1
7	sign, warning "compressor fluid fill cap"	049685	1
8	sign, air breathing (danger)	250027-935	1
9	decal, Sullair logo	02250059-048	2

(Continued on [page 127](#))

PLEASE NOTE: WHEN ORDERING PARTS, INDICATE SERIAL NUMBER OF COMPRESSOR

Section 8 ILLUSTRATIONS AND PARTS LIST

8.28 DECALS

⚠ WARNING



Use equipment grounding connector in accordance with the National Electrical Code, and all Federal State, and Local Codes, to help avoid possible ground fault shock hazard.

49852

10

⚠ WARNING



This Unit Is Equipped With An Auto Start Sequence That Will Start The Unit In The Event Of A Power Failure Automatically After The Sump Pressure Drops To 10 PSIG And The Power Is Restored.

When Performing Maintenance Follow Your Company's Prescribed Safety Practices for Electrical Equipment.

250017-903

11

CAUTION: This machine is equipped with Automatic Stop / Start Control System.

DO NOT ATTEMPT to make any adjustment without disconnecting both main line and control circuit electrical power.

41065

12

DANGER

HIGH VOLTAGE

4218

13

WATER

IN **OUT**

49872

14

↓ WATER IN ↓

250019-107

15

↓ WATER OUT ↓

250019-108

16

WATER DRAIN



250019-810

18

SULLUBE®

02250069-389

17A

24 KT®

02250069-395

17B

CP-4600-32-F

FOOD GRADE

333838-418-109220

17C

02250075-045



20

PE

02250075-510

21

02250075-045



22

460V

3 ~ 60 Hz

0225005220

19A

575V

3 ~ 60 Hz

0225005220

19B

380V

3 ~ 50 Hz

0225005220

19C

230V

3 ~ 60 Hz

0225005220

19D

23

⚠ WARNING

Mixing of other fluids will void warranty.

Fill cap has an o-ring seal. Do not use pipe dope.

02250110-891

Section 8

ILLUSTRATIONS AND PARTS LIST

8.28 DECALS (CONTINUED)

<i>key number</i>	<i>description</i>	<i>part number</i>	<i>quantity</i>
10	sign, warning ground fault	049852	1
11	decal, warning auto start	250017-903	1
12	decal, autostart	041065	1
12	decal, warning actuator	250029-836	1
13	decal, danger high voltage	042218	1
14	decal, water inlet-outlet	049873	1
15	decal, water in	250019-107	1
16	decal, water out	250019-108	1
17A	decal, fluid Sullube	02250069-389	1
17B	decal, fluid 24KT	02250069-395	1
17C	decal, fluid CP-4600-32-F	02250118-342	1
18	decal, water drain	250022-810	1
19A	decal, V 460/3/60 international	02250069-399	1
19B	decal, V 575/3/60 international	02250069-400	1
19C	decal, V 380/3/50 international	02250069-412	1
19D	decal, V 230/3/60 international	02250069-397	1
20	decal, protective earth ground	02250075-045	1
21	decal, PE designation	02250075-540	1
22	decal, earth ground	02250075-046	1
23	decal, warning mixing fluids	02250110-891	1

(Continued on [page 129](#))

PLEASE NOTE: WHEN ORDERING PARTS, INDICATE SERIAL NUMBER OF COMPRESSOR

Section 8 ILLUSTRATIONS AND PARTS LIST

8.28 DECALS

TS-32

24



25

27

24KT

26

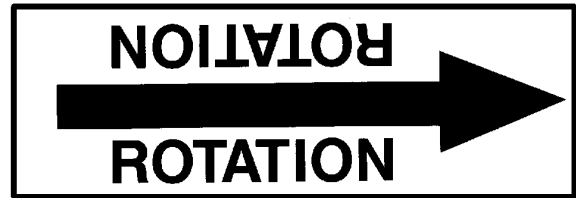

28

This product was manufactured to the highest quality standards in an ISO 9001 certified system.
 Ce produit a été fabriqué selon les normes les plus strictes de qualité dans un système ISO 9001 certifié.
 Dieses Produkt wurde in einem mit ISO 9001 Zertifikat versehenen System hergestellt und entspricht den höchsten Qualitätsnormen.
 Dette produkt er fremstillet i overensstemmelse med de strengeste kvalitetsnormer i et ISO 9001 - certificeret anlæg.

ISO 9001

Το προϊόν αυτό έχει κατασκευαστεί σύμφωνα με τις πλέον αυστηρές προδιαγραφές ποιότητας σε εγκατάσταση πιστοποιημένη με ISO 9001.
 Dit produkt werd volgens de hoogste kwaliteitseisen geproduceerd in een ISO-9001 gecertificeerd kwaliteitssysteem.
 Este producto ha sido fabricado según los más altos estándares de calidad en un sistema con la certificación ISO 9001.
 Questo prodotto è stato fabbricato secondo i più alti standard qualitativi, in un sistema omologato ISO 9001.
 本產品是由取得最高品質管水 ISO 9001 資格之製造廠所生產

© Copyright 1998 Sullair Corporation. All Rights Reserved

29

MACH. S/N _____ MODEL # _____
 CUST. NAME _____
 ADDRESS _____
 CITY / STATE _____ ZIP _____
 CUST. PRODUCT _____
 BRAND OF FLUID _____
 HOURS ON MACH. _____ FLUID _____
 DATE SAMPLE TAKEN: _____
 DISCHARGE TEMP. _____ °F
 AMBIENT TEMP. _____ °F
 FLUID USAGE RATE - GAL / MO. _____
 SAMPLE TAKEN FROM: _____
 COMMENTS: _____

250038-457

1 CR	1 TR	LINE PRESS	INLET
2 CR	2 TR	DISCH PRESS	T1
3 CR	3 TR	WATER PRESS	T2
4 CR	4 TR	SEPARATOR	T3
5 CR	1 M	SPIRAL VALVE	T4
6 CR	2 M	INLET VALVE	T5
1 FU	3 M	CIS VALVE	T6
2 FU	4 M	OIL PRESS	T3
3 FU	HCR	OIL FILTER	T4

30

**POWER
ENERGIZED**

31

32

← LIFT HERE →

241814

Section 8 ILLUSTRATIONS AND PARTS LIST

8.28 DECALS (CONTINUED)

<i>key number</i>	<i>description</i>	<i>part number</i>	<i>quantity</i>
24	decal, TS-32	02250061-379	1
25	decal, compressor fluid 24KT	02250061-022	1
26	decal, rotation	250021-564	1
27	decal, rotation	250021-286	1
28	decal, ISO 9001 (I)	-	1
29	decal, fluid sample	250022-675	1
30	decal, electrical component ID	250038-457	1
31	sign, power energized	249544-049	1
32	decal, fork lifting	241814	4

(I) ISO decal may vary per machine. To determine the proper part number of this decal, consult factory with machine serial number.

PLEASE NOTE: WHEN ORDERING PARTS, INDICATE SERIAL NUMBER OF COMPRESSOR

Section 8 ILLUSTRATIONS AND PARTS LIST

8.29 DECAL LOCATIONS

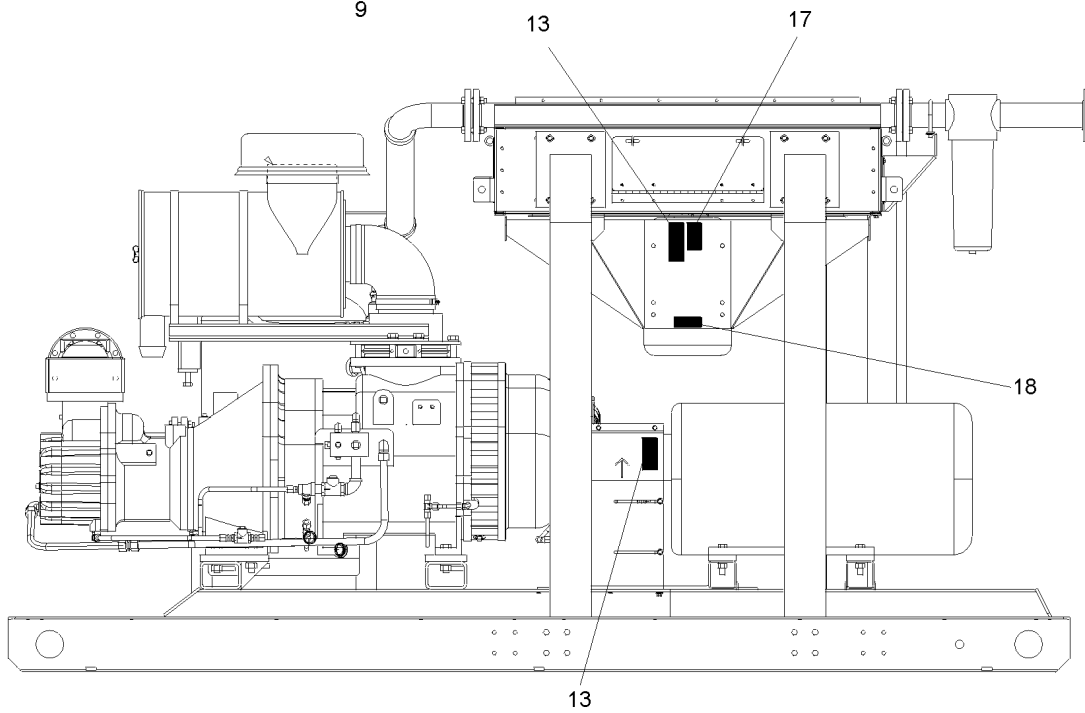
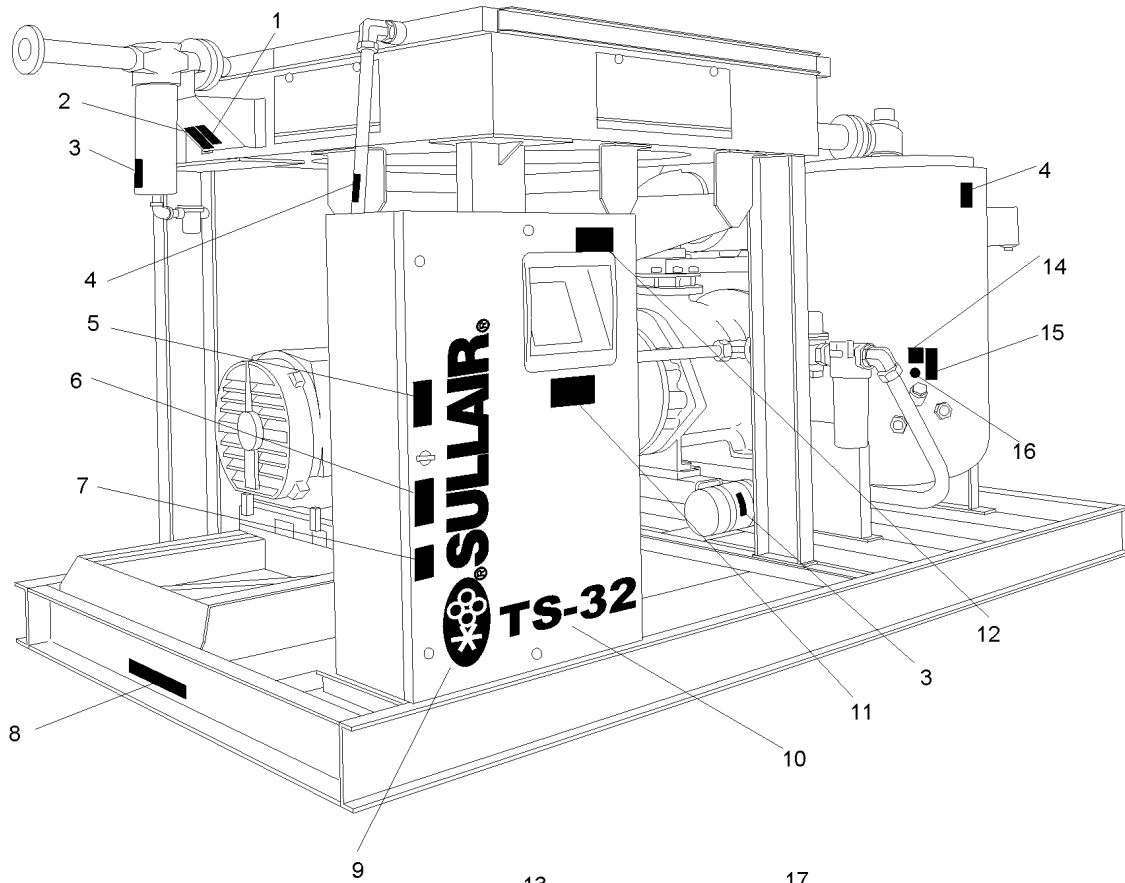

Section 8

ILLUSTRATIONS AND PARTS LIST

8.29 DECAL LOCATIONS

<i>key number</i>	<i>description</i>	<i>part number</i>	<i>quantity</i>
1	sign, air breathing (danger)	250027-935	1
2	sign, warning "food grade" lube	250003-144	1
3	decal, water drain	250022-810	1
4	decal, compressor fluid 24KT	02250061-022	1
5	sign, danger electrocution	049850	1
6	decal, warning auto start	250017-903	1
7	sign, warning sever - fan	049855	2
8	decal, fork lifting	241814	4
9	decal, Sullair logo	02250059-048	2
10	decal, TS-32	02250061-379	1
11	decal, ISO 9001 (I)	-	1
12	decal, autostart	041065	1
13	sign, warning sever - fan	049855	2
14	decal, warning mixing fluids	02250110-891	1
15	sign, warning "compressor fluid fill cap"	049685	1
16	decal, fluid (II)	-	
17	sign, warning sever-fan port	049965	1
18	decal, rotation	250021-564	1

(I) ISO decal may vary per machine. To determine the proper part number of this decal, consult factory with machine serial number.

(II) Fluid decal will vary per machine fill. To determine the compressor's proper fill decal, consult factory with machine serial number.

PLEASE NOTE: WHEN ORDERING PARTS, INDICATE SERIAL NUMBER OF COMPRESSOR

Section 8 ILLUSTRATIONS AND PARTS LIST

8.30 DECAL LOCATIONS- ENCLOSURE

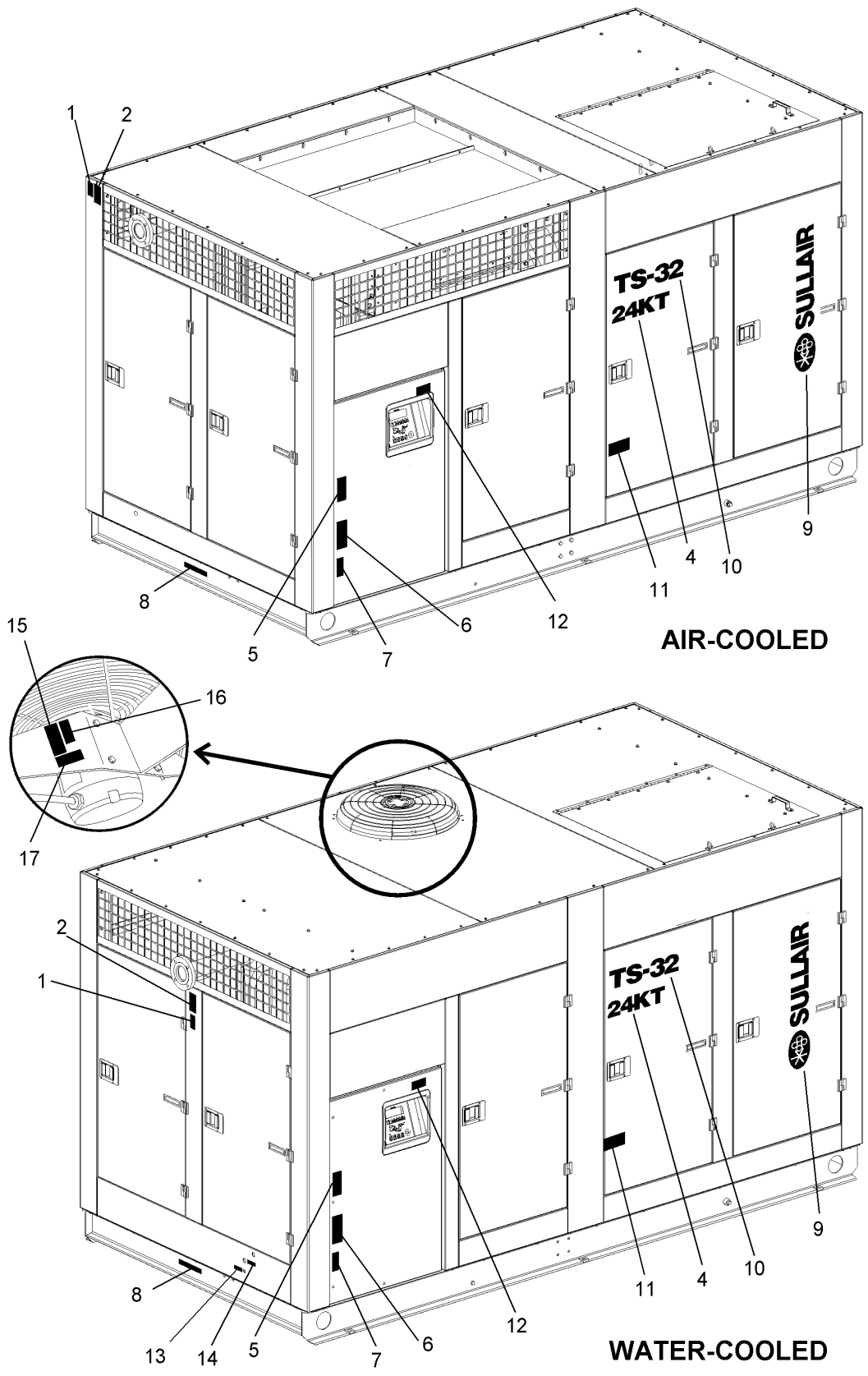

Section 8

ILLUSTRATIONS AND PARTS LIST

8.30 DECAL LOCATIONS- ENCLOSURE

<i>key number</i>	<i>description</i>	<i>part number</i>	<i>quantity</i>
1	sign, air breathing (danger)	250027-935	1
2	sign, warning "food grade" lube	250003-144	1
3	decal, water drain	250022-810	1
4	sign, warning hot surfaces	407408	1
5	sign, danger electrocution	049850	1
6	decal, warning auto start	250017-903	1
7	sign, warning sever - fan	049855	2
8	decal, fork lifting	241814	4
9	decal, Sullair logo	02250059-048	2
10	decal, TS-32	02250061-379	1
11	decal, ISO 9001 (I)	-	1
12	decal, autostart	041065	1
13	decal, water inlet-outlet	049873	1
14	sign, warning "compressor fluid fill cap"	049685	1
15	sign, warning sever-fan port	049965	1
16	decal, rotation	250021-564	1

(I) ISO decal may vary per machine. To determine the proper part number of this decal, consult factory with machine serial number.

PLEASE NOTE: WHEN ORDERING PARTS, INDICATE SERIAL NUMBER OF COMPRESSOR

Section 8 ILLUSTRATIONS AND PARTS LIST

8.31 DECAL LOCATIONS- CONTROL BOX

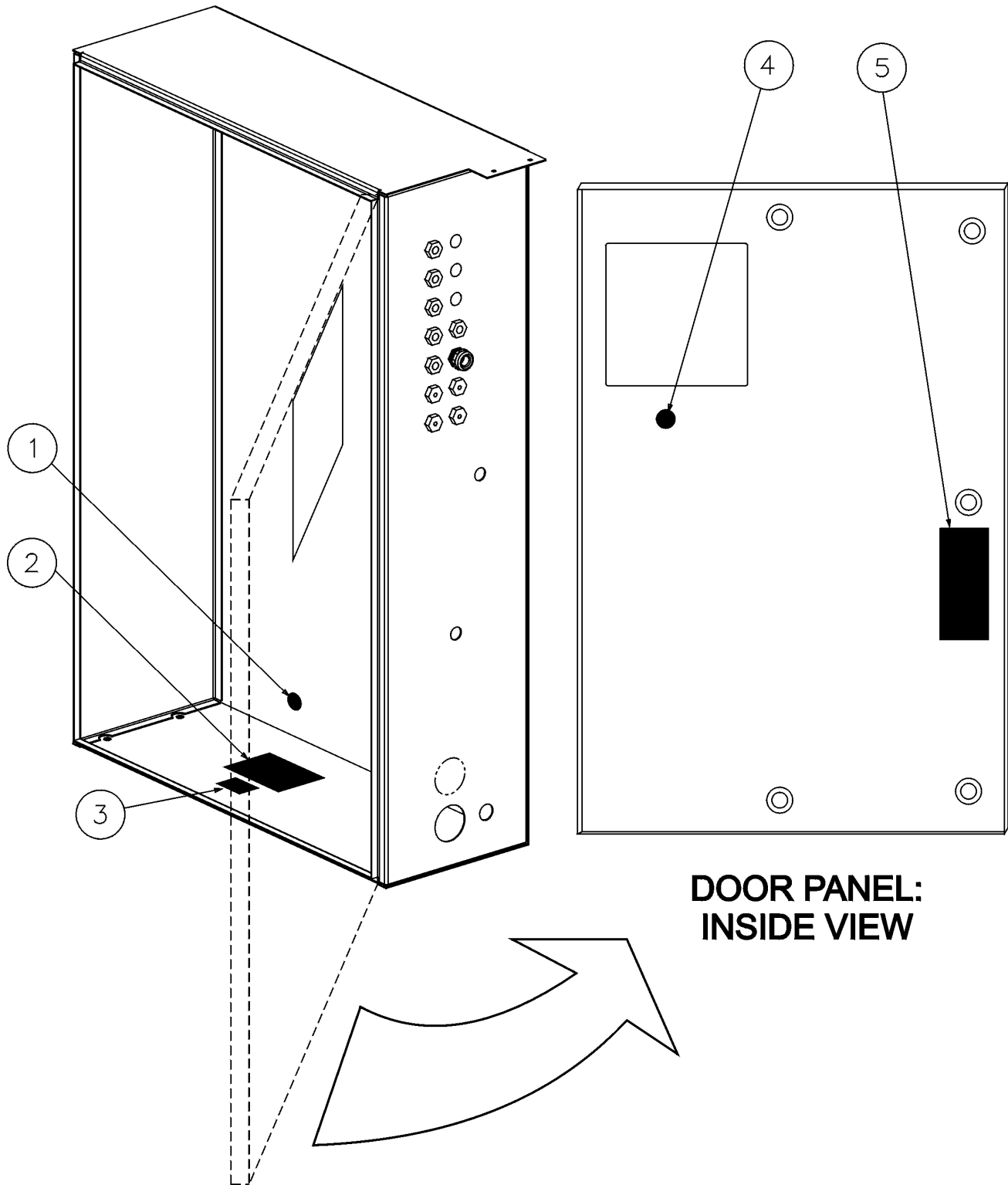

Section 8

ILLUSTRATIONS AND PARTS LIST

8.31 DECAL LOCATIONS- CONTROL BOX

<i>key number</i>	<i>description</i>	<i>part number</i>	<i>quantity</i>
1	decal, protective earth ground	02250075-045	2
2	decal, danger high voltage	042218	1
3	decal, V 460/3/60 international	02250069-399	1
	•decal, V 575/3/60 international	02250069-400	1
	•decal, V 380/3/50 international	02250069-412	1
	•decal, V 230/3/60 international	02250069-397	1
4	decal, PE designation	02250075-540	1
5	sign, warning ground fault	049852	1

PLEASE NOTE: WHEN ORDERING PARTS, INDICATE SERIAL NUMBER OF COMPRESSOR

Section 8 ILLUSTRATIONS AND PARTS LIST

8.33 WIRING DIAGRAM- WATER-COOLED/FULL VOLTAGE

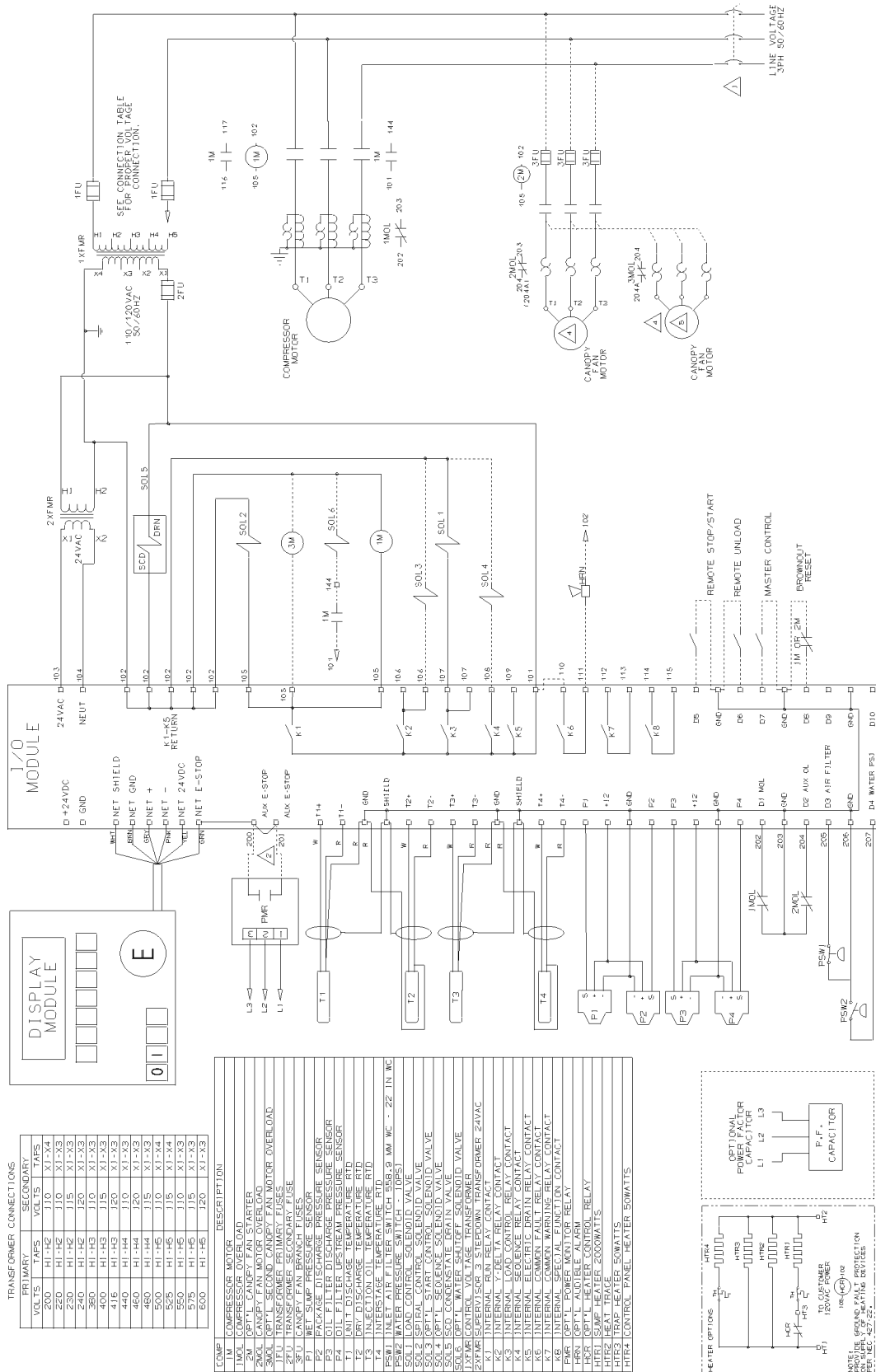

02250130-726R0

Section 8 ILLUSTRATIONS AND PARTS LIST

8.34 WIRING DIAGRAM- AIR-COOLED/WYE-DELTA

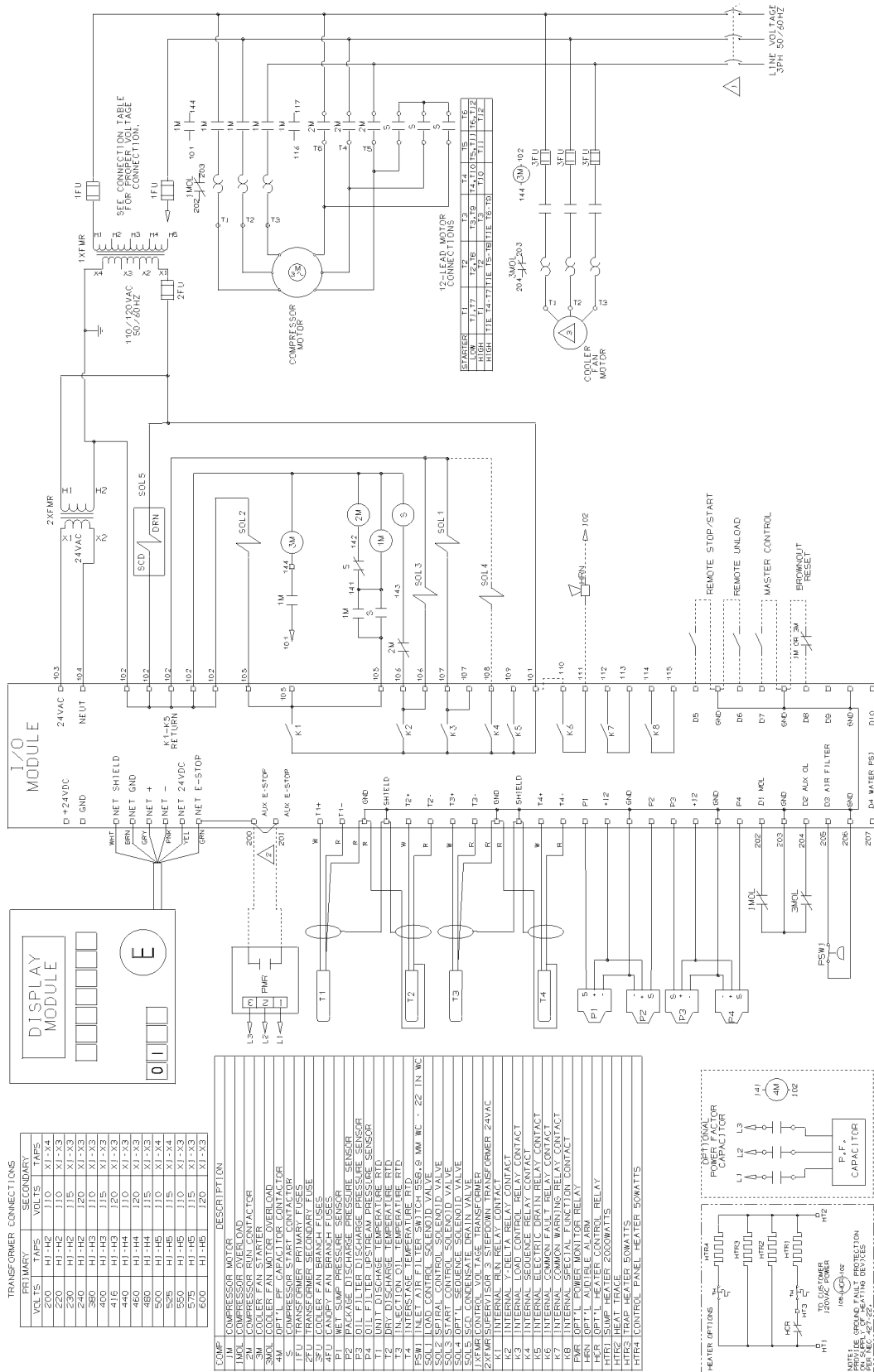

Section 8 ILLUSTRATIONS AND PARTS LIST

8.35 WIRING DIAGRAM- WATER-COOLED/WYE-DELTA

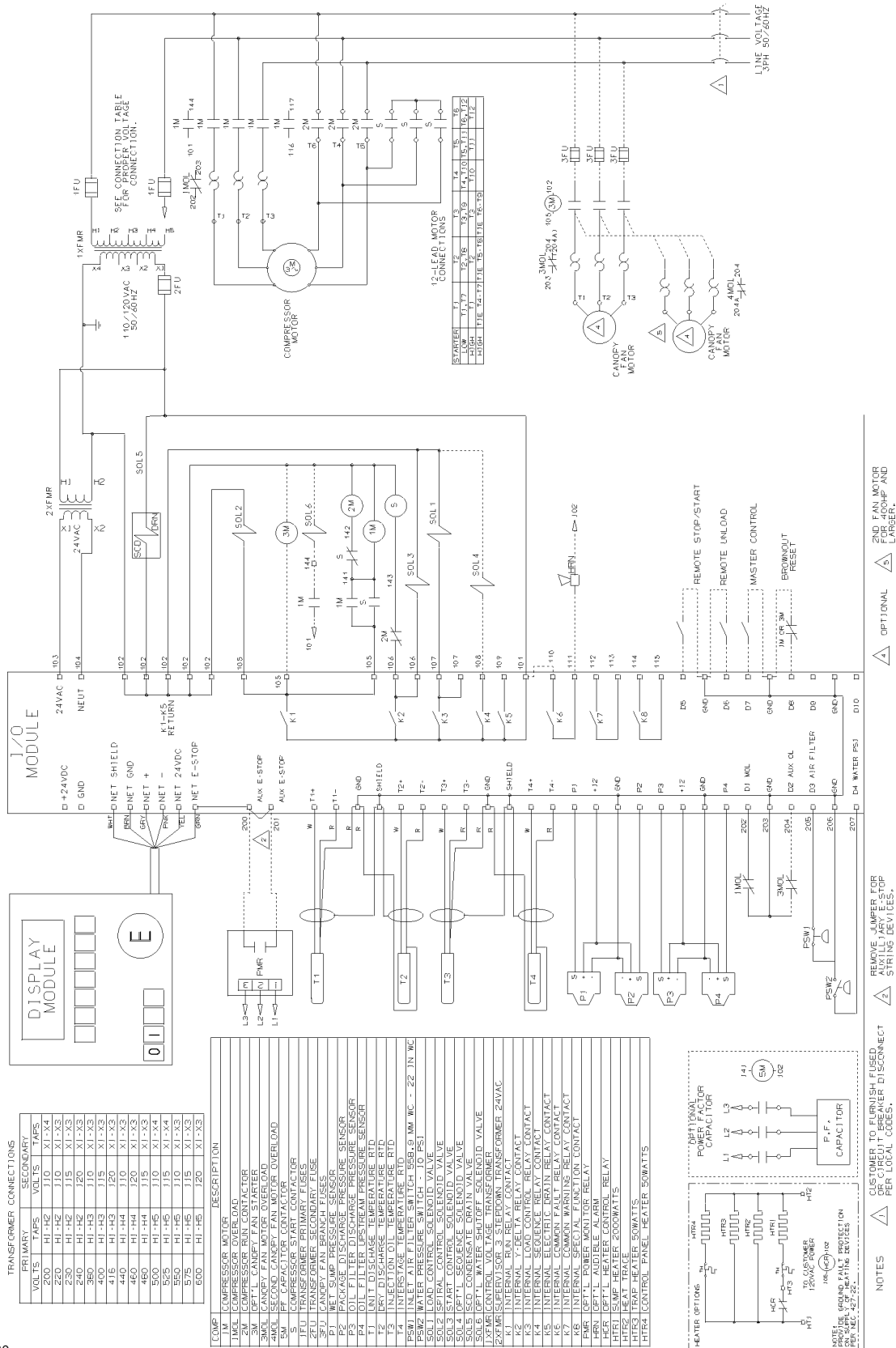

Section 8 ILLUSTRATIONS AND PARTS LIST

8.37 WIRING DIAGRAM- WATER-COOLED/SOLID STATE

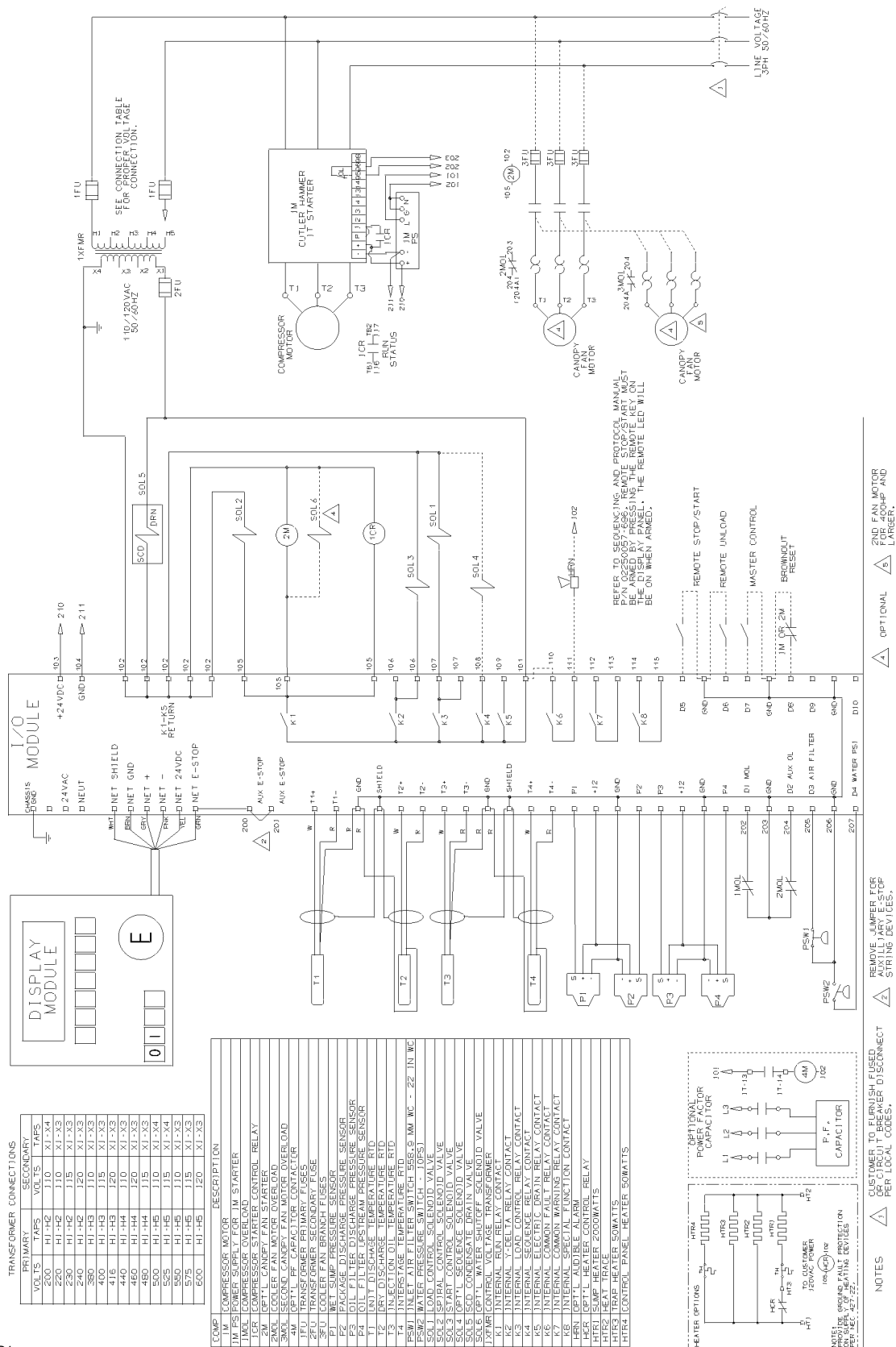

02250130-727R1

NOTES

WORLDWIDE SALES AND SERVICE

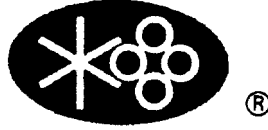

SULLAIR ASIA, LTD.
Sullair Road, No. 1
Chiwan, Shekou
Shenzhen, Guangdong PRV.
PRC POST CODE 518068
Telephone: 755-6851686
Fax: 755-6853473

SULLAIR EUROPE, S.A.
Zone Des Granges BP 82
42602 Montbrison Cedex, France
Telephone: 33-477968470
Fax: 33-477968499

SULLAIR CORPORATION
3700 East Michigan Boulevard
Michigan City, Indiana 46360 U.S.A.
Telephone: 1-800-SULLAIR (U.S.A. Only)
or 1-219-879-5451
Fax: (219) 874-1273
Fax: (219) 874-1835 (Parts)
Fax: (219) 874-1205 (Service)



Printed in the U.S.A.

Specifications Subject To
Change Without Prior Notice

E02