



**SULLAIR**  
**Refrigerated Air Dryer SRD**  
**Models 40 & 105**  
**R-22**

**OPERATOR'S  
MANUAL AND  
PARTS LIST**

Part Number 02250059-204  
©Sullair Corporation, 1994  
Effective 11/94

1194"

Kevin

## **AIR CARE SEMINAR TRAINING**

Sullair Air Care Seminars are 2-day courses that provide hands-on instruction in the proper operation, maintenance and service of Sullair Dryers and Filters. Seminars are presented at regular intervals throughout the year at a dedicated training facility at Sullair's corporate headquarters in Michigan City, Indiana.

Instruction includes discussion of the function and installation of Sullair service parts, troubleshooting of the most common problems, and actual equipment operation. The seminars are recommended for maintenance and service personnel.

For detailed course outlines, schedule and cost information contact:

Sullair Corporate Training Department  
1-800-SULLAIR or 219-879-5451 (ext. 1816)

- Or Write -

Sullair Corporation  
3700 E. Michigan Blvd.  
Michigan City, IN 46360  
Attn: Service Training Department

## TABLE OF CONTENTS

### Section 1 **SAFETY**

1	1.1 GENERAL
1	1.2 PERSONAL PROTECTIVE EQUIPMENT
1	1.3 PRESSURE
1	1.4 FIRE AND EXPLOSION
3	1.5 MOVING PARTS
3	1.6 HOT SURFACES, SHARP EDGES AND SHARP CORNERS
3	1.7 TOXIC AND IRRITATING SUBSTANCES
3	1.8 ELECTRICAL SHOCK
4	1.9 LIFTING
4	1.10 ENTRAPMENT

### Section 2 **DESCRIPTION**

5	2.1 INTRODUCTION
5	2.2 IDENTIFICATION OF COMPONENTS
6	2.3 REFRIGERANT CIRCUIT, FUNCTIONAL DESCRIPTION
7	2.4 COMPRESSED AIR CIRCUIT, FUNCTIONAL DESCRIPTION
7	2.5 REFRIGERANT SYSTEM COMPONENT, FUNCTIONAL DESCRIPTION

### Section 3 **SPECIFICATIONS**

8	TABLE OF SPECIFICATIONS
9	DIMENSIONS

### Section 4 **INSTALLATION**

10	4.1 GENERAL
10	4.2 MOUNTING OF DRYER
11	4.3 DRYER PIPING
11	4.4 ELECTRICAL PREPARATION

### Section 5 **OPERATION**

12	5.1 GENERAL
12	5.2 PURPOSE OF CONTROLS
12	5.3 INITIAL START-UP PROCEDURE
13	5.4 SUBSEQUENT START-UP PROCEDURE
13	5.5 NORMAL OPERATING CONDITIONS

## **TABLE OF CONTENTS**

(CONTINUED)

### Section 6

## **MAINTENANCE**

<b>14</b>	6.1 GENERAL
<b>14</b>	6.2 ROUTINE MAINTENANCE
<b>14</b>	6.3 TROUBLESHOOTING

### Section 7

## **ILLUSTRATIONS AND PARTS LIST**

<b>17</b>	7.1 PROCEDURE FOR ORDERING PARTS
<b>17</b>	7.1A RECOMMENDED SPARE PARTS LIST
<b>18</b>	7.2 AIR SYSTEM – SRD 40
<b>20</b>	7.3 AIR SYSTEM – SRD 105
<b>22</b>	7.4 REFRIGERANT SYSTEM – SRD 40
<b>24</b>	7.5 REFRIGERANT SYSTEM – SRD 105
<b>26</b>	7.6 ELECTRICAL SYSTEM – SRD 40
<b>28</b>	7.7 ELECTRICAL SYSTEM – SRD 105
<b>30</b>	7.8 FRAME, CANOPY AND PARTS – SRD 40 & 105
<b>32</b>	7.9 PIPING AND INSTRUMENTATION – SRD 40
<b>33</b>	7.10 PIPING AND INSTRUMENTATION – SRD 105
<b>34</b>	7.11 DECAL GROUP
<b>38</b>	7.12 WIRING DIAGRAM – SRD 40
<b>39</b>	7.13 WIRING DIAGRAM – SRD 105

# Section 1 SAFETY

## 1.1 GENERAL

Sullair Corporation designs and manufactures all of its products so they can be operated safely. However, the responsibility for safe operation rests with those who use and maintain these products. The following safety precautions are offered as a guide which, if conscientiously followed, will minimize the possibility of accidents throughout the useful life of this equipment.

The dryer should be operated only by those who have been trained and delegated to do so, and who have read and understood this operator's manual. Failure to follow the instructions, procedures and safety precautions in this manual can result in accidents and injuries.

**NEVER** start the dryer unless it is safe to do so. **DO NOT** attempt to operate the dryer with a known unsafe condition. Tag the dryer and render it inoperative by disconnecting and locking out all power at the source or otherwise disabling its prime mover so others, who may not know of the unsafe condition, will not attempt to operate it until the condition is corrected.

Use and operate the dryer only in full compliance with all pertinent OSHA regulations and/or all applicable Federal, State, and Local codes, standards and regulations.

**DO NOT** modify the dryer and/or controls in any way except with written factory approval.

While not specifically applicable to all types of dryers with all types of prime movers, most of the precautionary statements contained herein are applicable to most dryers and the concepts behind these statements are generally applicable to all dryers.

## 1.2 PERSONAL PROTECTIVE EQUIPMENT

Prior to installing or operating the dryer, owners, employers, and users should become familiar with, and comply with, all applicable OSHA regulations and/or any applicable Federal, State and Local codes, standards, and regulations relative to personal protective equipment, such as eye and face protective equipment, respiratory protective equipment, equipment intended to protect the extremities, protective clothing, protective shields and barriers and electrical protective equipment, as well as noise exposure administrative and/or engineering controls and/or personal hearing protective equipment.

## 1.3 PRESSURE

### **▲ WARNING**

**DO NOT** remove caps, plugs and/or other components when dryer is running or pressurized. Stop dryer and relieve all internal pressure before doing so.

**A.** Secure all connections by wire, chain or other suitable retaining devices to prevent tools or hose ends from being accidentally disconnected and expelled.

**B. DO NOT** overpressure the unit.

**C.** Vent all internal pressure prior to opening any air line, fitting, hose, valve, drain plug, connection or other component, such as filters and line oilers.

**D.** Keep personnel out of line with and away from the discharge opening of hoses or tools or other points of compressed air discharge.

**E.** Use air at pressures less than 30 psig (2.1 bar) for cleaning purposes, and then only with effective chip guarding and personal protective equipment per OSHA Standard 29 CFR 1910.242(b) and/or all applicable Federal, State and Local codes, standards and regulations.

**F. DO NOT** engage in horseplay with air hose as serious injury or death may result.

**G. DO NOT** pass air through the dryer while the dryer is in the **OFF** position.

**H. DO NOT** pass air through the dryer until the dryer has been stabilized. This condition exists when the refrigeration suction and discharge gauges read normal.

**I. DO NOT** operate a dryer at abnormal conditions. Consult the manual for normal operating conditions.

**J.** Only qualified personnel should attempt to repair leaks or problems with the refrigerant system of the dryer.

**K.** Potential Hazards of Fluorocarbon Refrigerants (see following tables).

## 1.4 FIRE AND EXPLOSION

**A.** Clean up spills of lubricant or other combustible substances immediately, when such spills occur.

**B.** Shut off the dryer and allow it to cool. Then keep sparks, flames and other sources of ignition away.

**C. DO NOT** permit fluids, including air line de-icer system antifreeze compound or fluid film to accumulate on under or around acoustical material, or on any external surfaces of the air dryer or on internal surfaces of the enclosure. Wipe down using an aqueous industrial cleaner or steam clean as required. If necessary, remove acoustical material, clean all surfaces and then replace acoustical material. Any acoustical material with a protective covering that has been torn or punctured should be replaced immediately to prevent accumulation of liquids or fluid film within the material. **DO NOT** use flammable solvents for cleaning purposes.

# Section 1 SAFETY

## POTENTIAL HAZARDS OF FLUOROCARBON REFRIGERANTS

**⚠ WARNING** Dryers contain HCFC. This substance harms the public health and environment by destroying the ozone in the upper atmosphere.

CONDITION	POTENTIAL HAZARD	SAFEGUARD
VAPORS MAY DECOMPOSE IN FLAMES OR IN CONTACT WITH HOT SURFACES	Inhalation of Toxic Decomposition Products.	Good ventilation. Toxic decomposition products serve as warning agents.  Avoid misuse.  Vent refrigerant outdoors.
VAPORS ARE 4 TO 5 TIMES HEAVIER THAN AIR. HIGH CONCENTRATIONS MAY TEND TO ACCUMULATE IN LOW PLACES.	Inhalation of Concentrated Vapors Can Be Fatal.	Avoid misuse.  Vent refrigerant outdoors.  Forced-air ventilation at the level of vapor concentration.  Individual breathing devices with air supply.  Lifelines when entering tanks or other confined areas.  <b>DO NOT</b> administer epinephrine or other similar drugs.
DELIBERATE INHALATION TO PRODUCE INTOXICATION.	Can Be Fatal.	Avoid misuse.  Vent refrigerant outdoors.  Forced-air ventilation at the level of vapor concentration.  Individual breathing devices with air supply.  Lifelines when entering tanks or other confined areas.  <b>DO NOT</b> administer epinephrine or other similar drugs.
SOME FLUOROCARBON LIQUIDS TEND TO REMOVE NATURAL OILS FROM THE SKIN.	Irritation of Dry, Sensitive Skin.	Gloves and protective clothing.
LOWER BOILING LIQUIDS MAY BE SPLASHED ON SKIN.	Freezing of Skin.	Gloves and protective clothing.
LIQUIDS MAY BE SPLASHED INTO EYES.	Lower Boiling Liquids May Cause Freezing. Higher Boiling Liquids May Cause Temporary Irritation And If Other Chemicals Are Dissolved, May Cause Damage.	Wear eye protection. Get medical attention. Flush eyes for several minutes with running water.
CONTACT WITH HIGHLY REACTIVE METALS.	Violent Explosion May Occur.	Test the proposed system and take appropriate safety precautions.

## CRITICAL PROPERTIES OF REFRIGERANTS

REFRIGERANT	CRITICAL TEMPERATURE		CRITICAL PRESSURE	
	°F	°C	Psia	kg/cm <sup>2</sup>
"Freon" 22	205	96	722	50.8

**D.** Disconnect and lock out all power at source prior to attempting any repairs or cleaning of the dryer or of the inside of the enclosure, if any.

**E.** Keep electrical wiring, including all terminals and pressure connectors in good condition. Replace any wiring that has cracked, cut, abraded or otherwise degraded insulation, or terminals that are worn, discolored or corroded. Keep all terminals and pressure connectors clean and tight.

**F.** Keep grounded and/or conductive objects such as tools away from exposed live electrical parts such as terminals to avoid arcing which might serve as a source of ignition.

**G.** Remove any acoustical material or other material that may be damaged by heat or that may support combustion and is in close proximity, prior to attempting weld repairs.

**H.** Keep suitable fully charged Class BC or ABC fire extinguisher or extinguishers nearby when servicing and operating the dryer.

**I.** Keep oily rags, trash, leaves, litter or other combustibles out of and away from the dryer.

**J. DO NOT** operate the dryer without proper flow of cooling air or water or with inadequate flow of lubricant or with degraded lubricant.

**K. DO NOT** attempt to operate the compressor and dryer in any classification of hazardous environment unless the compressor and dryer has been specially designed and manufactured for that duty.

### 1.5 MOVING PARTS

**A.** Keep hands, arms and other parts of the body and also clothing away from couplings, fans and other moving parts.

**B. DO NOT** attempt to operate the dryer with the fan, coupling or other guards removed.

**C.** Wear snug fitting clothing and confine long hair when working around this dryer, especially when exposed to hot or moving parts.

**D.** Keep access doors, if any, closed except when making repairs or adjustments.

**E.** Make sure all personnel are out of and/or clear of the dryer prior to attempting to start or operate it.

**F.** Disconnect and lock out all power at source and verify at the dryer that all circuits are de-energized to minimize the possibility of accidental start-up or operation prior to attempting repairs or adjustments. This is especially important when compressors and dryers are remotely controlled.

**G.** Keep hands, feet, floors, controls and walking surfaces clean and free of fluid, water or other liquids to minimize the possibility of slips and falls.

### 1.6 HOT SURFACES, SHARP EDGES AND SHARP CORNERS

**A.** Avoid bodily contact with hot fluid, hot coolant, hot surfaces and sharp edges and corners.

**B.** Keep all parts of the body away from all points of air discharge.

**C.** Wear personal protective equipment including gloves and head covering when working in, on or around the dryer.

**D.** Keep a first aid kit handy. Seek medical assistance promptly in case of injury. **DO NOT** ignore small cuts and burns as they may lead to infection.

### 1.7 TOXIC AND IRRITATING SUBSTANCES

**A. DO NOT** use air from this dryer for respiration (breathing) except in full compliance with OSHA Standards 29 CFR 1910 and/or any other Federal, State or Local codes, standards and regulations.

**B. DO NOT** use air line anti-icer systems in air lines supplying respirators or other breathing air utilization equipment and **DO NOT** discharge air from these systems in unventilated or other confined areas.

**C.** Operate the dryer only in open or adequately ventilated areas.

## **▲ DANGER**

Death or serious injury can result from inhaling compressed air without using proper safety equipment. See OSHA standards and/or all applicable Federal, State and Local codes, standards and regulations on safety equipment.

### 1.8 ELECTRICAL SHOCK

**A.** This dryer should be installed and maintained in full compliance with all applicable Federal, State and Local codes, standards and regulations, including those of the National Electrical Code, and also including those relative to equipment grounding conductors, and only by personnel who are trained, qualified and delegated to do so.

**B.** Keep all parts of the body and any hand-held tools or other conductive objects away from exposed live parts of electrical system. Maintain dry footing, stand on insulating surfaces and **DO NOT** contact any other portion of the dryer when making adjustments or repairs to exposed live parts of the electrical system. Make all such adjustments or repairs with one hand only, so as to minimize the possibility of creating a current path through the heart.

**C.** Attempt repairs in clean, dry and well lighted and ventilated areas only.

**D. DO NOT** leave the dryer unattended with open electrical enclosures. If necessary to do so, then disconnect, lock out and tag all power at source so others will not inadvertently restore power.

# Section 1

## SAFETY

E. Disconnect, lock out, and tag all power at the source prior to attempting repairs or adjustments to rotating machinery and prior to handling any ungrounded conductors.

### 1.9 LIFTING

A. Dryers to be lifted by helicopter must be supported by slings. In any event, lift and/or handle only in full compliance with OSHA standards 29 CFR 1910 subpart N, and/or all applicable Federal, State and Local codes, standards and regulations.

B. Inspect points of attachment for cracked welds and for cracked, bent, corroded or otherwise degraded members and for loose bolts or nuts prior to lifting.

C. Make sure entire lifting, rigging and supporting structure has been inspected, is in good condition and has a rated capacity of at least the weight of the dryer. If you are unsure of the weight, then weigh dryer before lifting.

D. Make sure lifting hook has a functional safety latch or equivalent, and is fully engaged and latched on the bail or slings.

E. Use guide ropes or equivalent to prevent twisting or swinging of the dryer once it has been lifted clear of the ground.

F. **DO NOT** attempt to lift in high winds.

G. **DO NOT** lift dryer by motor lifting eye.

H. Keep all personnel out from under and away from the dryer whenever it is suspended.

I. Lift dryer no higher than necessary.

J. Keep lift operator in constant attendance whenever dryer is suspended.

K. Set dryer down only on level surfaces capable of safely supporting at least its weight and unit loading equipment.

L. When moving dryers by forklift truck, utilize fork pockets if provided. Otherwise, utilize pallet if provided. If neither fork pockets or pallet are provided, then make sure dryer is secure and well balanced on forks before attempting to raise or transport it any significant distance.

M. Make sure forklift truck forks are full engaged and tipped back prior to lifting or transporting the dryer.

N. Forklift no higher than necessary to clear obstacles at floor level and transport and corner at minimum practical speeds.

O. Make sure pallet mounted dryers are firmly bolted or otherwise secured to the pallet prior to attempting to forklift or transport them. **NEVER** attempt to forklift a dryer that is not secured to its pallet, as uneven floors or sudden stops may cause the dryer to tumble off, possibly causing serious injury or property damage in the process.

### 1.10 ENTRAPMENT

A. If the dryer enclosure is large enough to hold a man and if it is necessary to enter it to perform service adjustments, inform other personnel before doing so, or else secure and tag the access door in the open position to avoid the possibility of others closing and possibly latching the door with personnel inside.

B. Make sure all personnel are out of dryer before closing and latching enclosure doors.

Section 2  
**DESCRIPTION**

**2.1 INTRODUCTION**

This manual provides information and recommendations for installing, operating and servicing the Sullair Refrigerated Air Dryer (SRD). The unit is designed and manufactured to the highest quality standards. All self-contained units have been fully tested and inspected by the manufacturer before shipment from the factory.

The information, specifications and illustrations in this manual are in accordance with information in effect at the time of printing. The manufacturer reserves the right to change design and specifications without notice and without incurring obligations.

It is extremely important to analyze completely every system and understand the intended function of each component before attempting to determine the cause of a malfunction or failure.

The refrigerant (R-22) and air circuit can be easily followed by referring to the table in Section 3 Specifications.

A refrigerant suction pressure gauge is provided as standard equipment for analyzing the system operation and performance.

Any question or problem not covered herein can be directed to the nearest Sullair representative. Always specify the model and serial number of the dryer on all correspondence regarding service and parts.

**2.2 IDENTIFICATION OF COMPONENTS**

Refer to Figure 2-1. Parts can be ordered from the nearest Sullair representative. If for any reason parts cannot be obtained in this manner, contact the factory. Authorization and shipping instructions must be obtained from the factory before returning the parts to the factory. The manufacturer will not be responsible for parts returned without proper authorization or identification.

The Sullair Refrigerated Air Dryer (SRD) is designed for the purpose of removing moisture from compressed air by cooling to a temperature of 35°F to 39°F (2°C to 4°C).

*Figure 2-1 Identification of Components (SRD 105) (Typical)*

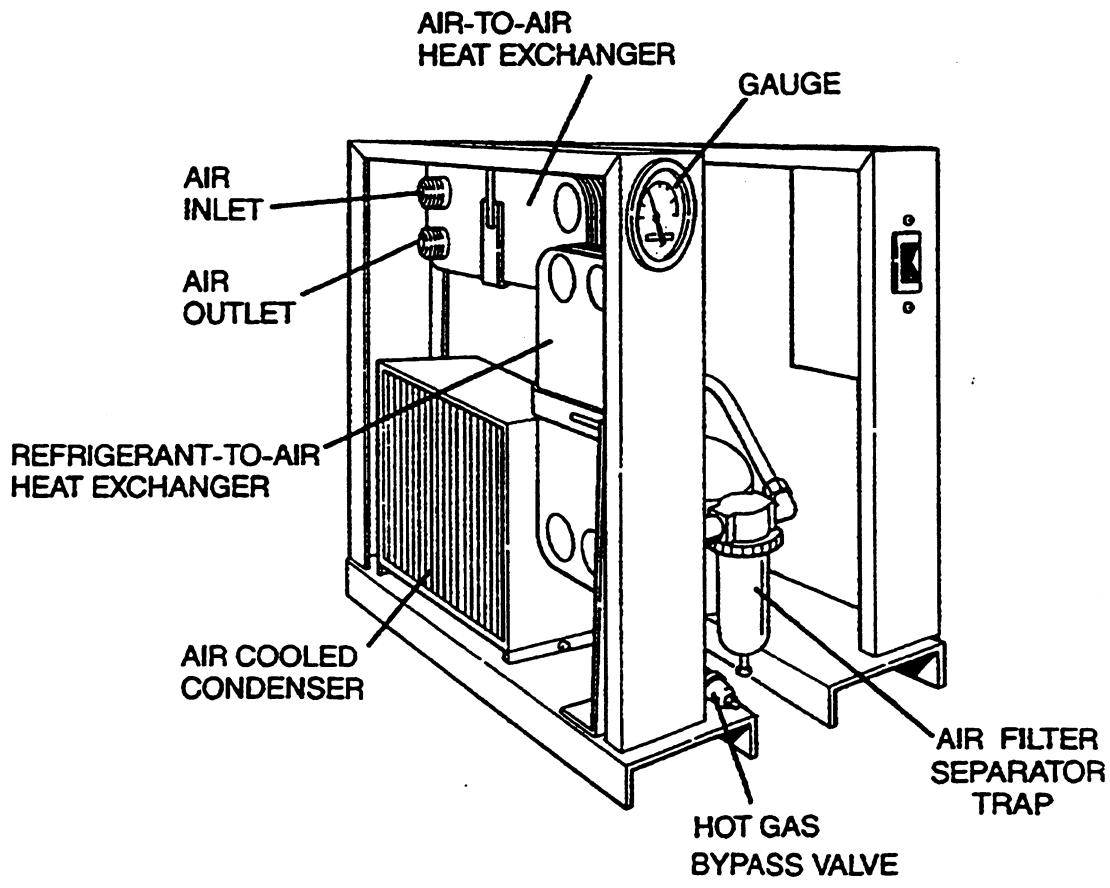

## Section 2 DESCRIPTION

### 2.3 REFRIGERANT CIRCUIT, FUNCTIONAL DESCRIPTION

The SRD dryer cools the process air by the use of a closed-loop vapor compression refrigeration cycle. Refer to Figure 2-2, for the flow schematics.

Dry R-22 vapor enters the compressor inlet and its pressure and temperature are raised at discharge. The vapor continues through a condenser, where it is cooled to its liquid state at near constant pressure. A filter dryer then removes any water and impurities that may be carried by the refrigerant. A further reduction of temperature and pressure takes place as the liquid R-22 is throttled through a capillary tube. The resulting mixture of vapor and liquid picks up heat (does cooling) as it moves through the

evaporator, where it turns back to its vapor state and routes back to the compressor inlet port.

To prevent feeding the compressor with liquid R-22 and evaporator icing during low heat rejection operation (i.e., partial process air flow), a pressure operated valve bypasses hot R-22 vapor to the evaporator inlet, thus assuring thorough evaporation of the refrigerant.

To insure that adequate head pressure is maintained during periods of low ambient temperatures or partial loads, a switch located at the compressor discharge cycles the condenser fan. If the head pressure is too low to insure adequate flow through the hot gas bypass valve, the condenser fan is shut off.

Figure 2-2 Dryer Flow Schematic Model SRD 40, 105

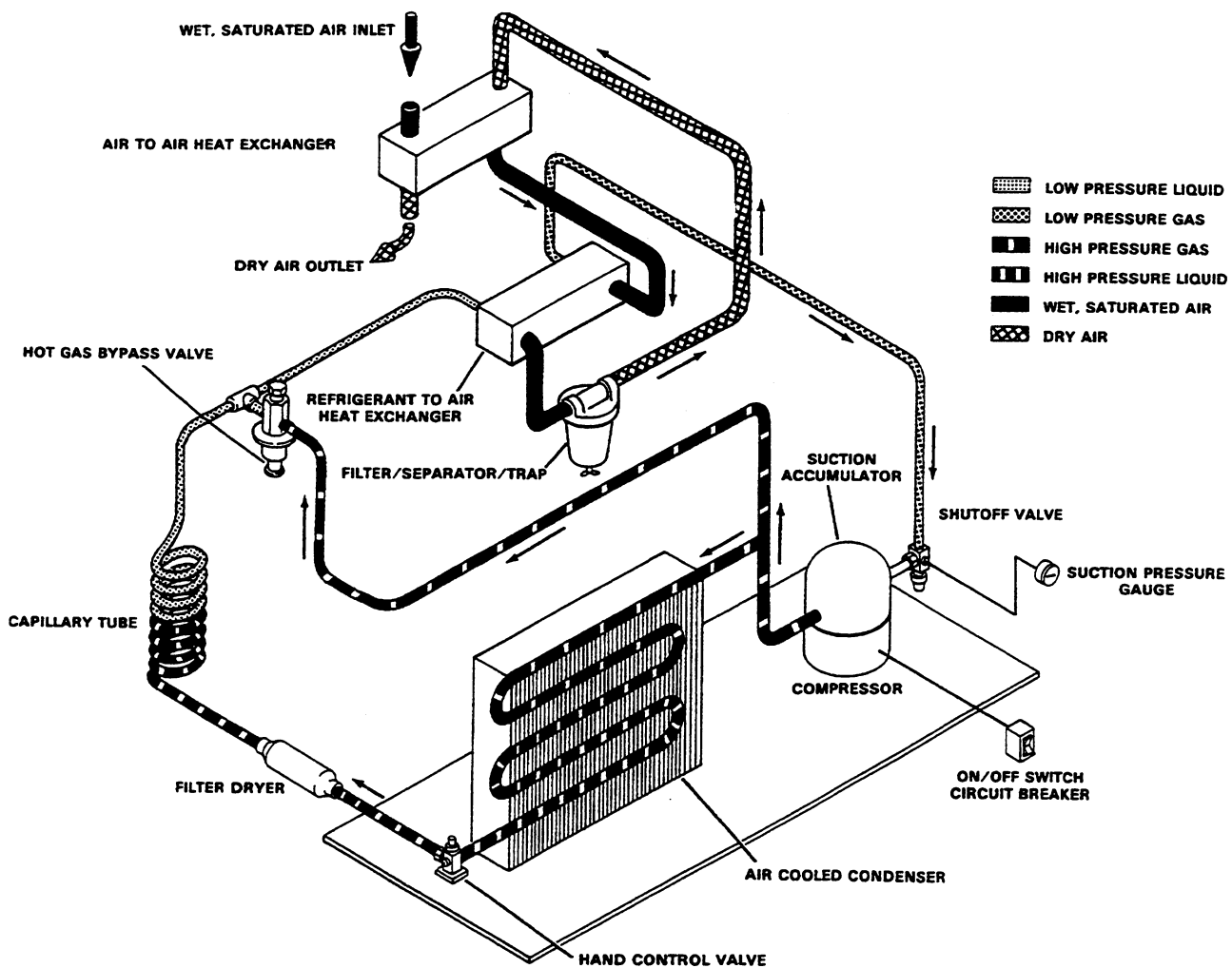

#### **2.4 COMPRESSED AIR CIRCUIT, FUNCTIONAL DESCRIPTION**

The compressed air drying circuit uses an air-to-air heat exchanger which acts as a precooler/reheater, and an air-to-refrigerant heat exchanger (evaporator).

Warm, saturated, compressed air first enters the air-to-air heat exchanger, where it is precooled. By precooling the incoming air, energy is saved through the reduction of the heat load imposed on the refrigerant compressor and condenser. From the precooler, the air will enter the evaporator further reducing its temperature 35°F to 39°F (2°C to 4°C). Moisture is condensed and then separated by a cyclone separator and discharged through an automatic float-type drain trap.

The chilled air then reenters the air-to-air heat exchanger, where it is reheated. Reheating of the air does not affect the air's dewpoint. It prevents condensation of moisture on the outside of the air-distribution piping. The cold air flow through the air-to-air heat exchanger is in a direction opposite to the flow of the warm, saturated incoming air. This counterflow assures high temperature differential throughout the heat exchanger, resulting in a more effective heat transfer.

#### **2.5 REFRIGERANT SYSTEM COMPONENT, FUNCTIONAL DESCRIPTION**

The refrigerant **compressor** compresses low pressure refrigerant gas into high pressure refrigerant gas.

The air-cooled **condenser** changes high pressure refrigerant gas from compressor discharge into high pressure liquid as the gas flows through.

The **filter/dryer** removes any contaminant and moisture that may be in the system.

The **capillary tube** is a non-adjustable metering device which separates the high pressure side of the system from the low pressure side. The capillary tube controls the flow of refrigerant to the evaporator in order to maintain a non-adjustable temperature difference (super-heat) between the evaporator refrigerant inlet and outlet (see Figure 2-2).

The **hot gas bypass valve (HGBV)** is used to artificially load the evaporator during part-load conditions. The HGBV accomplishes this task by diverting high pressure gas from the compressor discharge to the inlet of the evaporator. The HGBV separates the high pressure side of the system from the low pressure side. The HGBV will modulate from fully open to fully closed in response to its outlet pressure setting. The HGBV is set to maintain the minimum allowable suction line pressure.

The **refrigerant-to-air heat exchanger** chills the compressed air to achieve a 35°F to 39°F (2°C to 4°C) temperature. A low pressure liquid/gas mixture enters the refrigerant side of the heat exchanger and removes heat from the warm compressed air. The refrigerant changes phases as it passes through the heat exchanger and exits as a low pressure super-heated gas.

# Section 3 SPECIFICATIONS

Figure 3-1 SRD Specifications – Models 40-105

MODEL		SRD 40	SRD 105
Flow Capacity (I)	SCFM at 39°F (4°C) Evaporator Outlet Air Temperature	40	105
	M <sup>3</sup> /hr. at 4°C Evaporator Outlet Air Temperature	68	178
Power Input (KW/HP)		.52/1.7	.82/1.1
Air Inlet/Outlet Connection (MPT)		1"	1"
Drain Connection (FPT)		1/4	1/4
Refrigerant Compressor HP/KW Rating		.2/15	.5/37
Maximum Heat of Rejection BTU/HR / KCAL/HR		3692/930	8308/2094
R-22 Cooling Air Flow (CFM/M <sup>3</sup> /Hr.)		220/374	350/595
Refrigerant/Charge (lbs./kg.)		.75/34	.81/37
Standard Voltage (Optional) (II)		A	A/B
Total Power Input – Amps/Coulombs		5.0/18000	11.9/42840
Height	(inches)	23.25	23.25
	(mm)	591	591
Width	(inches)	17.12	17.12
	(mm)	435	435
Length	(inches)	24.5	24.5
	(mm)	622	622
Weight	(lbs.)	106	112
	(kgs.)	48	51

(I) Flow Capacity rating is based on 100°F (38°C) air inlet temperature, 100 psig (6.9 bar) air inlet pressure and 100°F (38°C) ambient temperature.

(II) Voltage Code:                      A – 115/1/60                      B – 230/1/60

# Section 3 SPECIFICATIONS

Figure 3-2 Dimensions - Models 40 - 105

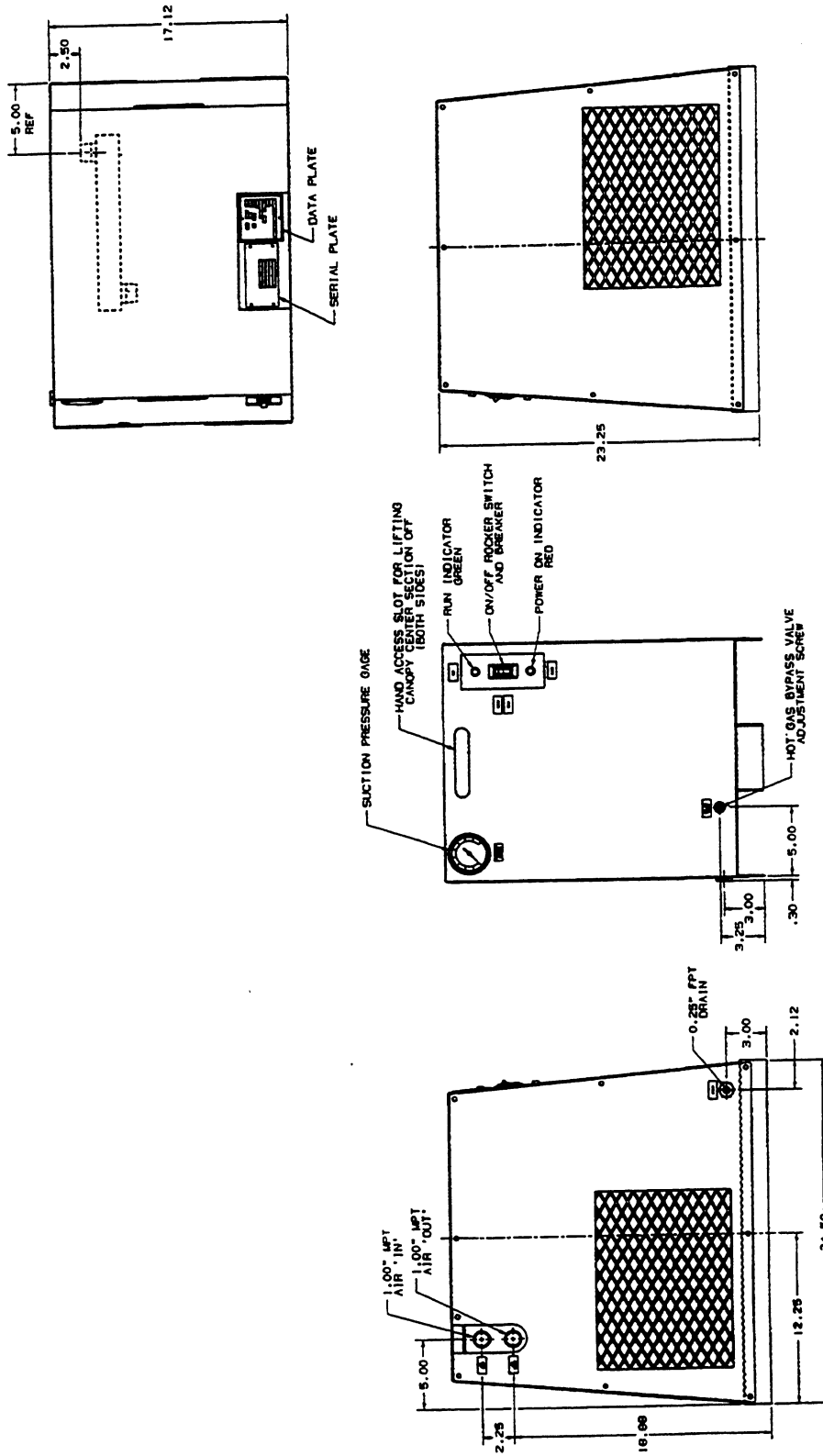

# Section 4 INSTALLATION

## 4.1 GENERAL

Each dryer is test run at the factory before shipment. Immediately upon receipt of the equipment, remove the cabinet and check the unit carefully for any physical damage that may have occurred in transit.

If there is any physical damage or a refrigerant leak, please file a claim with the shipper immediately and notify your Sullair representative or the factory of the nature of the damage. The carrier is legally responsible for any damages. Your Sullair representative or Sullair Corporation will assist in any way possible to rectify problems.

After you are assured that the unit has sustained no shipping damage, the dryer is ready for installation.

## 4.2 MOUNTING OF DRYER

The dryer should be installed in an area that is clean and dry, allowing sufficient space on all sides for routine maintenance and service. The unit should be shielded from the weather elements, with ambient temperature above 65°F (18°C) and not more than 100°F (38°C). Occasional operation at ambient temperature up to 120°F (49°C) will not damage the dryer, but will affect the capacity and dewpoint. Temperatures below 35°F (2°C) can cause freeze-ups of the condensate drains. If prolonged periods below 35°F (2°C) are expected, a heat source for

these areas will have to be provided.

### ⚠ CAUTION

SRD 40-105 are not equipped with a crankcase heater. Installation of these dryers in areas with ambient temperatures below 65°F (18°C) can result in compressor damage.

Sufficient ventilation must be provided to maintain acceptable ambient temperature for efficient operation.

SRD Refrigerated Air Dryers are designed to operate with saturated air at the inlet. They should be installed downstream of a functioning aftercooler/separator combination to prevent slugging the dryer with liquid water. It is also highly recommended to install a Sullair PF or MPF prefilter upstream of the SRD.

### ⚠ CAUTION

A Sullair PF or MPF prefilter should be installed upstream of the SRD dryer to prevent contamination of the plate heat exchangers.

Figure 4-1 Typical Rotary and Piston Compressor Air System

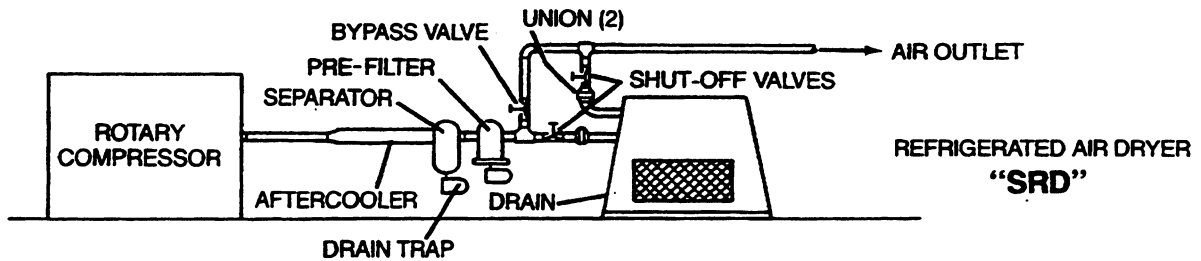

TYPICAL ROTARY COMPRESSOR AIR SYSTEM

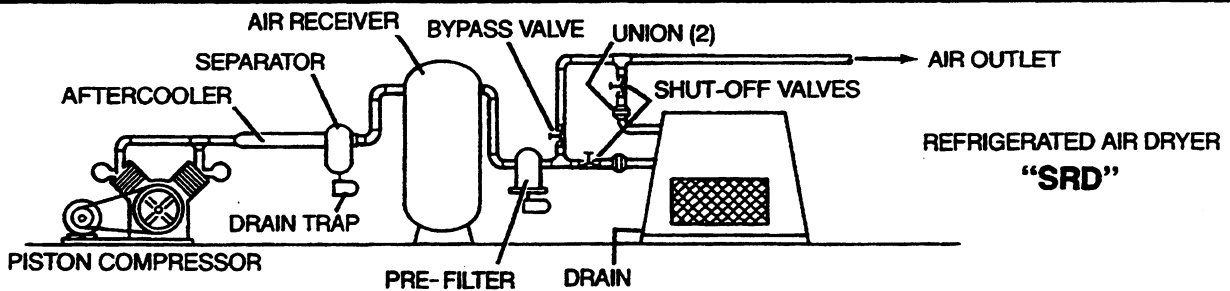

TYPICAL PISTON COMPRESSOR AIR SYSTEM

## NOTE

A foundation or mounting capable of supporting the weight of the machine, and rigid enough to maintain the frame level is required.

## ⚠ WARNING

All piping between compressor outlet and dryer inlet must be clean of all particulate by flushing or comparable cleaning method before initial air run through dryer.

### 4.3 DRYER PIPING

## ⚠ WARNING

“The Plastic Pipe Institute recommends against the use of thermoplastic pipe to transport compressed air or other compressed gases in exposed above ground locations, e.g. in exposed plant piping.” (I)

Sullube 32 should not be used with PVC piping systems. It may affect the bond at cemented joints. Certain other plastic materials may also be affected.

(I) Plastic Pipe Institute, Recommendation B, Adopted January 19, 1972.

Refer to Figure 4–1. Compressed air piping should be at least of equal size to that furnished on the inlet and outlet of the dryer. Larger pipes reduced to the inlet/outlet pipe size may be used. It is recommended that shut-off valves with unions be installed at each port, with a valved bypass to permit isolation of the unit for servicing to eliminate the need of shutting down the plant air system.

Make sure, when piping is connected, that undue stress is not applied on the dryer fittings.

Drain lines should be sloped adequately to drain by gravity any water accumulated after separation.

Drains must be connected directly to a proper disposal system.

### 4.4 ELECTRICAL PREPARATION

Refer to Section 7 Wiring Diagrams. The nameplate on the instrument panel of each unit identifies the power supply requirements. A suitably fused disconnect switch in compliance with the National and Local Electrical Code requirements is recommended.

The wiring of all functional electrical components has been designed and manufactured in accordance with the following electrical codes/practices:

NEC – National Electrical Codes

NEMA – National Electrical Manufacturers Association

UL – Underwriters Laboratories – Recognized Components

CSA – Canadian Standards Association – Recognized Components

As stated in Section 1, Safety, use a qualified electrician for all electrical wiring. Connect the power supply lines to the terminals indicated on the wiring diagram corresponding to your unit. All units are supplied with control circuit protection and a “red” power indicating light (On SRD units, with the control circuit transformer provided, a fuse is connected on primary side of the control circuit transformer to protect the unit from overcurrent and short circuit.)

Connect ground wire to provided ground lug.

The compressors and fans are single phase and will turn only in the correct direction (fan must pull air across the condenser).

## NOTE

Grounding of the frame is required.

# Section 5

## OPERATION

### 5.1 GENERAL

While Sullair has built into this dryer controls and indicators to assist you in determining if it is operating properly, it will be necessary to recognize and interpret the condition which will call for service or indi-

cate the beginning of a malfunction. Before starting the Sullair dryer, read this section thoroughly and familiarize yourself with the controls and indicators – their purpose, location and use.

### 5.2 PURPOSE OF CONTROLS

CONTROL OR INDICATOR	PURPOSE
REFRIGERANT SUCTION PRESSURE GAUGE	Indicates the refrigerant pressure as it enters the compressor. Before start-up, it is equivalent to the ambient temperature converted to pressure e.g. at 70°F (21°C) ambient temperature, R-22 suction pressure is 121 psig (8.3 bar) (see Figure 5-1, Temperature Pressure Chart).

### 5.3 INITIAL START-UP PROCEDURE

After the installation has been completed, the following items should be checked.

1. Check main electrical supply for proper input voltage. On units supplied with a control circuit transformer, a fuse is provided on the primary side.
2. Check proper connection and support of compressed air lines to the dryer (complete with bypass valving system).
3. Check that inlet air temperature and pressure to the dryer meet the specification requirements.

#### ▲ CAUTION

Make certain that all shut-off valves in the refrigerant circuit are open. Starting the dryer with a valve closed could burn up the compressor. Rotate valve clockwise to open.

4. For SRD 40-105, turn on the main disconnect and power switch to the dryer. The power indicating light will be on.

#### ▲ CAUTION

SRD 40-105 are not equipped with a crankcase heater. Installation of these dryers in areas with ambient temperatures below 65°F (18°C) can result in compressor damage.

5. Check that the bypass valve in the main air line is open and the shutoff valve to the dryer is closed.
6. Check the refrigerant suction pressure. This should be checked with no air flowing through the dryer, with a head pressure of 170 psig (11.7 bar), and without the condenser fan cycling.
  - a) The suction pressure should be 58-60 psig (4.0 to 4.1 bar). It is normal for the dryer to cycle between these pressures. During this cycling the suction pressure should not fall below 58 psig (4 bar).
  - b) If the fan cycles during the checking of the suction pressure, a jumper wire may be installed around the fan cycling switch to temporarily prevent cycling.

- c) To achieve the proper head pressure for checking the suction pressure, the following should be done. To increase the head pressure increase the ambient air temperature or temporarily restrict the air flow to the condenser. To reduce the head pressure, the ambient temperature must be reduced.
- d) Allow the dryer to run at least 15 minutes for stabilization when checking and adjusting the suction pressure.
- e) If necessary, adjust the hot gas bypass valve (HGBV) to change the suction pressure. Turn clockwise to increase the suction pressure and counterclockwise to decrease the suction pressure.
- f) Remove the jumper wire which was installed around the fan cycling switch in Step "b" above.

#### NOTE

If the suction pressure was set or checked at a head pressure greater than 170 psig (11.7 bar), a suction pressure lower than 58 psig (4.0 bar) may result, which could result in evaporator icing.

7. Open the dryer shutoff valve slowly and close the bypass valve. Apply full rated air flow to the dryer at its rating conditions. Rating conditions are 100°F (38°C) entering air temperature, 100 psig (6.9 bar) entering air pressure and 100°F (38°C) ambient air temperature.
8. Check the refrigerant suction pressure for normal operating conditions. See Section 5.5.
  - a) If necessary, take corrective action as described in the Troubleshooting Section of this manual (See 6.3 Troubleshooting).

#### NOTE

The hot gas bypass valve is preset at the factory. However, it may require readjustment at initial installation and periodically to help assure the suction pressure remains in the specified range, as stated in this Operator's Manual. If the suction pressure is too low, icing of the evaporator is possible.

## Section 5 OPERATION

### 5.4 SUBSEQUENT START-UP PROCEDURE

1. Turn on the power switch on the dryer.
2. With the air shutoff valve closed, check the suction pressure for a normal operating condition. If it is not within the normal unload range of 58 – 60 psig (4.0 to 4.1 bar), immediately take corrective action utilizing the Troubleshooting section of this manual.
3. Open the air shutoff valve slowly and apply load to the dryer. Check the suction pressure, head pressure, sight glass and moisture indicator for normal operating conditions as shown in Section 5.5 of this manual.

### 5.5 NORMAL OPERATING CONDITIONS

After the dryer has been started under rated load, let the dryer run for at least 15 minutes to allow stabilization of the system.

*Figure 5-1 Temperature Pressure Chart*

Temperature (°F/°C)	(psig/bar) R-22	Temperature (°F/°C)	(psig/bar) R-22
20/-7	43/3.0	70/21	121/8.3
22/-6	45/3.1	75/24	132/9.1
24/-4	48/3.3	80/27	144/9.9
26/-3	50/3.5	85/29	156/10.8
28/-2	52/3.6	90/32	168/11.6
30/-1	55/3.8	95/35	182/12.6
32/0	58/4.0	100/38	195/13.4
34/1	60/4.1	105/41	211/14.6
36/2	63/4.4	110/43	226/15.6
38/3	66/4.6	115/46	243/16.8
40/4	69/4.8	120/49	260/17.9
45/7	76/5.2	125/52	278/19.1
50/10	84/5.8	130/54	297/20.5
55/13	93/6.4	140/60	337/23.2
60/16	102/7.0	150/66	381/26.3
65/18	111/7.7	160/71	430/29.7

The gauge readings should be as follows:

#### REFRIGERANT SUCTION PRESSURE

R-22 fully loaded is 65 psig (4.5 bar) and unloaded is 58 psig (4.0 bar).

#### NOTE

Add 1 psig (0.7 bar) to the minimum allowable suction pressures referred to in manual for each 2,000 ft (610m) elevation above sea level.

#### REFRIGERANT HEAD PRESSURE

To the ambient temperature add 25°F to 30°F (15°C to 18°C) then convert to pressure using the Temperature Pressure Chart (Figure 5-1). For proper dryer operation, the minimum discharge head pressure required is 150 psig (10.3 bar).

# Section 6

## MAINTENANCE

### 6.1 GENERAL

As you proceed in reading this section, it will be easy to see that the Maintenance Program for the dryer is quite minimal. The use of the service indicators will alert you when service maintenance is required. Checks on a regular basis on the dryer will help insure that all items are functioning properly.

### 6.2 ROUTINE MAINTENANCE

Check automatic condensate trap on a regular basis to insure that it is operating properly or the emulsion will back up into the compressed air system. Proper drain trap and valve maintenance is the owner's responsibility and is not covered by the warranty.

The condenser fins may need to be periodically cleaned to remove dust, lint, etc., to assure efficient heat transfer. High head pressure or a visual check will determine the need for cleaning.

### TROUBLESHOOTING

Check the gauge readings periodically for good system operation.

Before working on the refrigerant system, read the Safety Section 1.3 pertaining to pressure.

### 6.3 TROUBLESHOOTING

The dryer consists of three basic systems: Air, Refrigerant and Electrical. An air leak at 100 psig (6.9 bar) will provide an audible signal indicating where there is a problem; R-22 has no color or odor, therefore a small refrigerant leak is difficult to find. However, it can be detected by a bubble test, halide torch (with a flame which changes from red-orange to blue on contact with refrigerant) or an electronic detector.

The electrical system consists of transformers, starter, switches, relays, etc. The use of a volt-ohm meter or similar equipment is required for checking continuity, amperage and voltage.

SYMPTOM	PROBABLE CAUSE	REMEDY
UNIT DOES NOT RUN	No Line Voltage	Follow wiring diagram and check voltage from compressor terminal to the power source to find where the circuit was interrupted.  Inspect electrical components such as switches, controls, motors, transformers, etc.  The supply power voltage, frequency and phase must coincide with unit's nameplate.
	Improperly Wired	Check wiring against wiring diagram and tighten any loose connection.
	Blown Fuse Or Tripped Circuit Breaker	Check for amperage draw of unit.
HEAD PRESSURE TOO HIGH	Refrigerant Overcharge	Excess refrigerant; check unit's nameplate for total system refrigerant charge.  Refrigerant overcharge may cause system not to perform properly and efficiently.
	Condenser Fouled And Dirty	Dismantle and clean condenser.  Clogged fins in air-cooled condenser will reduce heat transfer efficiently. Fins should be periodically checked and cleaned.
	Defective Fan Control Switch	Replace.  Fan control cuts in at 215 psig (14.8 bar) and cuts out at 170 psig (11.7 bar).
	Defective Fan Motor	Replace.
	Dryer Location Too Hot (high ambient)	Cool ambient or relocate the unit (see Section 4, Installation; Location of Dryer).
	Compressed Air Leaks To Refrigerant System.	Evacuate, repair leak and recharge with refrigerant.  Repair or replace evaporator.

**TROUBLESHOOTING**

SYMPTOM	PROBABLE CAUSE	REMEDY
HEAD PRESSURE TOO LOW	Low Ambient Temperature	Increase ambient temperature. If ambient temperature is too low, dryer freeze up can take place. Add some type of head pressure control.
	Refrigerant Shortage	Check for leaks in the system; repair, and recharge with proper amount – see specs.
	Defective Fan Control Switch	Replace. Fan should cut out at 170 psig (11.7 bar).
SUCTION PRESSURE TOO LOW	Hot Gas Bypass Valve Out Of Adjustment Or Defective	Adjust or replace. Turn clockwise to increase suction pressure; See Section 5.5 for normal operating conditions.
	Refrigerant Shortage	Add enough refrigerant to maintain desired suction pressure. Also check amperage draw.
	Excessive Pressure Drop In High Side	Check for any restriction (plugged filter drier) Suction pressure should be steady and vary only 1 to 3 psig (0.1 to 0.2 bar) from high to low at this condition.
	Head Pressure Too Low Due To Defective Fan Control Switch	Replace.
SUCTION PRESSURE TOO HIGH	Hot Gas Bypass Valve Out Of Adjustment Or Defective	Turn counterclockwise to lower suction pressure to desired reading. Compressed air dewpoint will rise as the suction pressure increases.
	Refrigerant Overcharge	Excess refrigerant; check unit's nameplate for total system refrigerant charge.  Refrigerant overcharge may cause system not to perform properly and efficiently.
WATER IN THE COMPRESSED AIR SYSTEM	Drain Traps Clogged	Disassemble and clean traps to restore free flow of drainage. Check drain lines. Automatic drain traps are ballfloat type and do not need priming. It should be disassembled and cleaned after two weeks of operation.
	Air Bypass System Open	Close air bypass valve (see Section 5.3 Operation; Initial Start-up Procedure).
	Improperly Set Or Malfunctioning Hot Gas Bypass Valve, Or Fan Cycling Switch	Will be indicated by suction pressure being too high. Adjust or replace.
	Ambient Temperature Is Too High	Remove ambient or improve ventilation.

# NOTES

# ILLUSTRATIONS AND PARTS LIST

## 7.1 PROCEDURE FOR ORDERING PARTS

Parts should be ordered from the nearest Sullair Representative or the Representative from whom the dryer was purchased. If for any reason parts cannot be obtained in this manner, contact the factory directly at the address or phone numbers below.

When ordering parts always indicate the Serial Number of the dryer. This can be obtained from the Bill of Lading for the dryer or from the Serial Number Plate located on the dryer.

**SULLAIR CORPORATION**  
 Subsidiary of Sundstrand Corporation  
 3700 East Michigan Boulevard  
 Michigan City, Indiana 46360 U.S.A.  
 Telephone: 1-800-SULLAIR or  
 1-219-879-5451  
 FAX: (219) 874-1273  
 FAX: (219) 874-1835 (Parts)  
 FAX: (219) 874-1805 (Service)

**SULLAIR ASIA, LTD.**  
 ROOM 2304A  
 Shartex Plaza Ctr.  
 No. 88 Zun Yi Nan Rd.  
 Shanghai, P.R.C.  
 Telephone: 21-2192066  
 FAX: 21-2196568

**SULLAIR EUROPE, S.A.**  
 Chemin de Genas BP 639  
 69800 Saint Priest, France  
 Telephone: 33-72232425  
 FAX: 33-78907168

## 7.1A RECOMMENDED SPARE PARTS LIST

DESCRIPTION (I)	KIT NUMBER	QUANTITY
kit, sep/trap filter repair (02250056-841)	02250056-842 (bowl/auto drain)	1
	02250056-843 (baffle/reflector)	1
	02250056-844 (element/o-ring)	1

**PLEASE NOTE: WHEN ORDERING PARTS, ALWAYS INDICATE SERIAL NUMBER OF DRYER UNIT.**

# ILLUSTRATIONS AND PARTS LIST

## 7.2 AIR SYSTEM – SRD 40

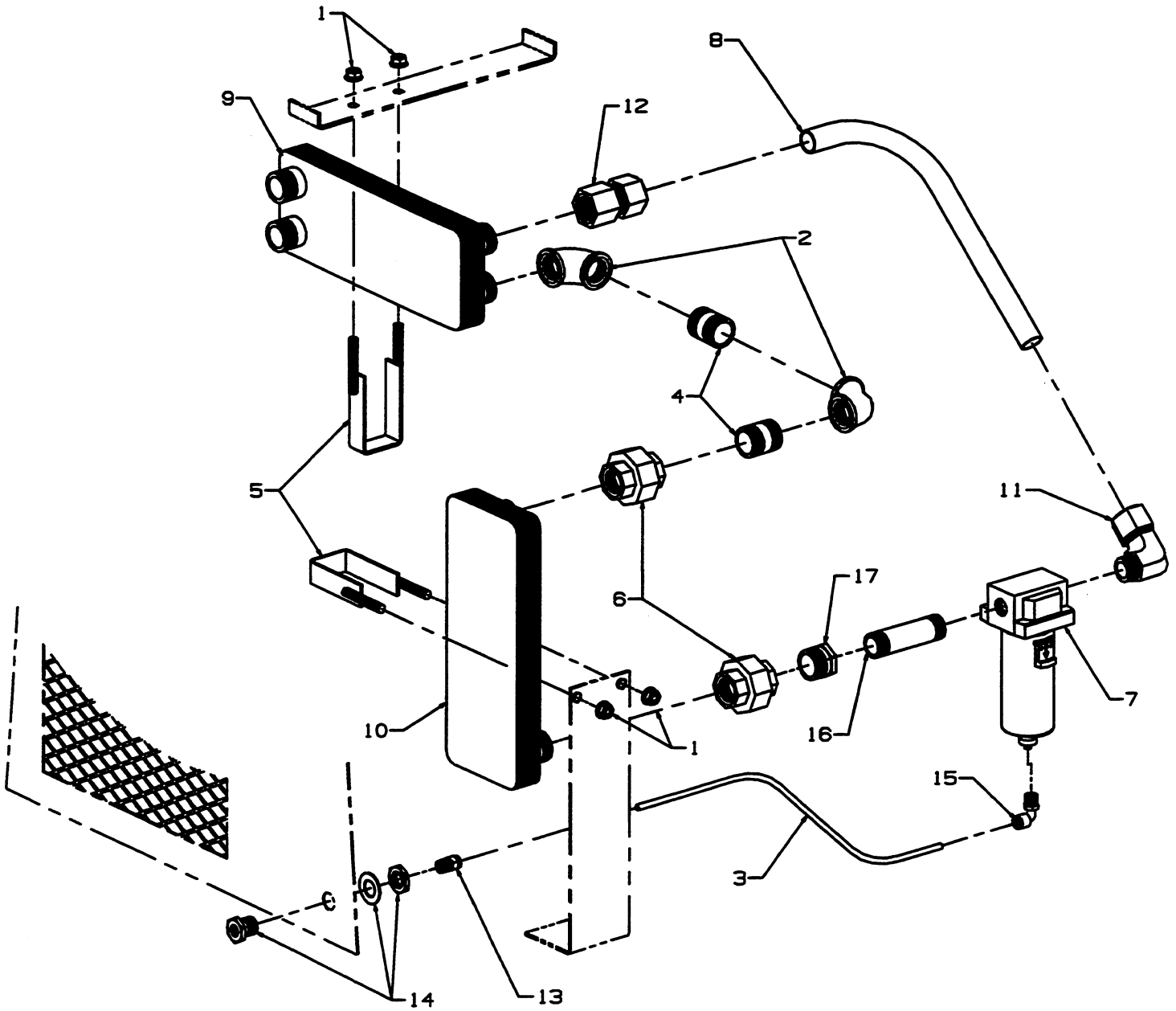

# ILLUSTRATIONS AND PARTS LIST

---

## 7.2 AIR SYSTEM – SRD 40

<i>key number</i>	<i>description</i>	<i>part number</i>	<i>quantity</i>
1	nut, hex female 3/8" – 16	825306–347	4
2	elbow, pipe 90° 1" 150#	801515–040	2
3	tubing, thermal plastic 1/4" o.d.	250024–745	2 ft.
4	nipple, pipe xs 1" x close	822216–000	2
5	u–bolt, cooler mounting	250033–043	2
6	union, pipe 1" npt	802515–040	2
7	filter, sep/trap SRD 40–105 (I)	02250056–841	1
8	tubing, steel 1"	250033–144	1
9	heat exchanger, AxA plate seal	250027–253	1
10	evaporator, fxa pltseal 100scfm	02250059–283	1
11	elbow, tube–m 1" x 3/4"	810516–075	1
12	connector, tube–m 1" x 3/4"	810116–100	1
13	connector, starter t–m 1/4" x 1/4" push–on	250024–685	1
14	bulkhead, pipe 1/4" npt	841500–004	1
15	connector, t–m swivel 1/4" x 1/4"	250024–704	1
16	nipple, pipe 3/4" x 3 1/2"	822112–035	1
17	bushing, reducing hex 1" x 3/4"	802104–030	1

(I) For maintenance on separator/trap filter no. 02250056–841, order bowl/auto drain repair kit no. 02250056–842; baffle/reflector repair kit no. 02250056–843; element/o–ring repair kit no. 02250056–844.

---

**PLEASE NOTE: WHEN ORDERING PARTS, ALWAYS INDICATE SERIAL NUMBER OF DRYER UNIT.**



# ILLUSTRATIONS AND PARTS LIST

---

## 7.3 AIR SYSTEM – SRD 105

<i>key number</i>	<i>description</i>	<i>part number</i>	<i>quantity</i>
1	filter, sep/trap SRD 40–105 (I)	02250056–841	1
2	bulkhead, pipe 1/4" npt	841500–004	1
3	nut, hex female 3/8" –16	825306–347	4
4	nipple, pipe xs 1" x close	822216–000	2
5	nipple, pipe 3/4" x 3	822112–030	1
6	elbow, tube–m 1" x 3/4"	810516–075	1
7	connector, tube–m 1" x 3/4"	810116–100	1
8	union, pipe 1" npt	802515–040	2
9	bushing, reducing hex 1" x 3/4"	802104–030	1
10	elbow, pipe 90° 1" 150#	801515–040	2
11	tubing, steel 1"	250033–144	1
12	u–bolt, cooler mounting	250033–043	2
13	evaporator, FxA plate seal 4	250027–266	1
14	heat exchanger, AxA plate seal	250027–254	1
15	tubing, thermal plastic 1/4" o.d.	250024–745	2 ft.
16	connector, starter t–m 1/4" x 1/4" push–on	250024–685	1
17	connector, t–m swivel 1/4" x 1/4"	250024–704	1

(I) For maintenance on separator/trap filter no. 02250056–841, order bowl/auto drain repair kit no. 02250056–842; baffle/reflector repair kit no. 02250056–843; element/o–ring repair kit no. 02250056–844.

---

**PLEASE NOTE: WHEN ORDERING PARTS, ALWAYS INDICATE SERIAL NUMBER OF DRYER UNIT.**

# ILLUSTRATIONS AND PARTS LIST

## 7.4 REFRIGERANT SYSTEM – SRD 40

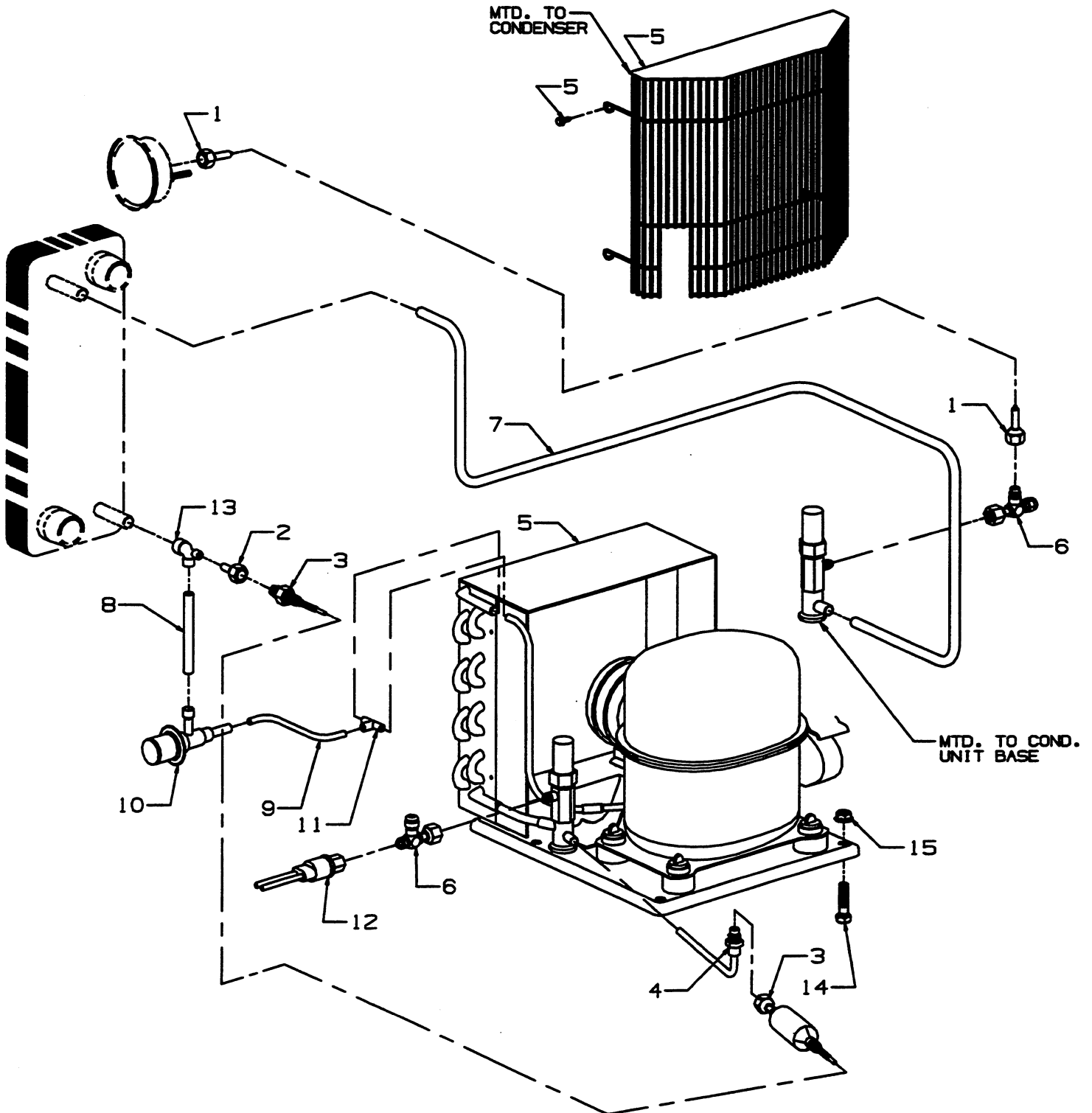

# ILLUSTRATIONS AND PARTS LIST

---

## 7.4 REFRIGERANT SYSTEM – SRD 40

<i>key number</i>	<i>description</i>	<i>part number</i>	<i>quantity</i>
1	line, gauge 1/4" flare x 30" lg	250022-040	1
2	nut, access assembly	250033-737	1
3	filter, dryer w/capillary	02250059-648	1
4	valve, access trt.	250023-191	1
5	unit, condensing 1/5 HP/.15KW	02250059-282	1
6	valve, access tee 1/4"	250032-322	3
7	tube, comp inlet 3/8"	02250059-666	1
8	tube, hot gas outlet 3/8"	02250059-665	1
9	tube, hot gas vlv inlet 3/8"	02250059-664	1
10	valve, hot gas	02250058-536	1
11	tee, copper 1/4"	805400-025	1
12	switch, press fan cut-out	02250058-534	1
13	tee, sldr red 1/2" x 1/4" x 3/8"	805508-046	1
14	capscr, hex 5/16" x 1 1/4"	828605-125	4
15	nut, hx 5/16"	825305-283	4

---

**PLEASE NOTE: WHEN ORDERING PARTS, ALWAYS INDICATE SERIAL NUMBER OF DRYER UNIT.**

# ILLUSTRATIONS AND PARTS LIST

## 7.5 REFRIGERANT SYSTEM – SRD 105

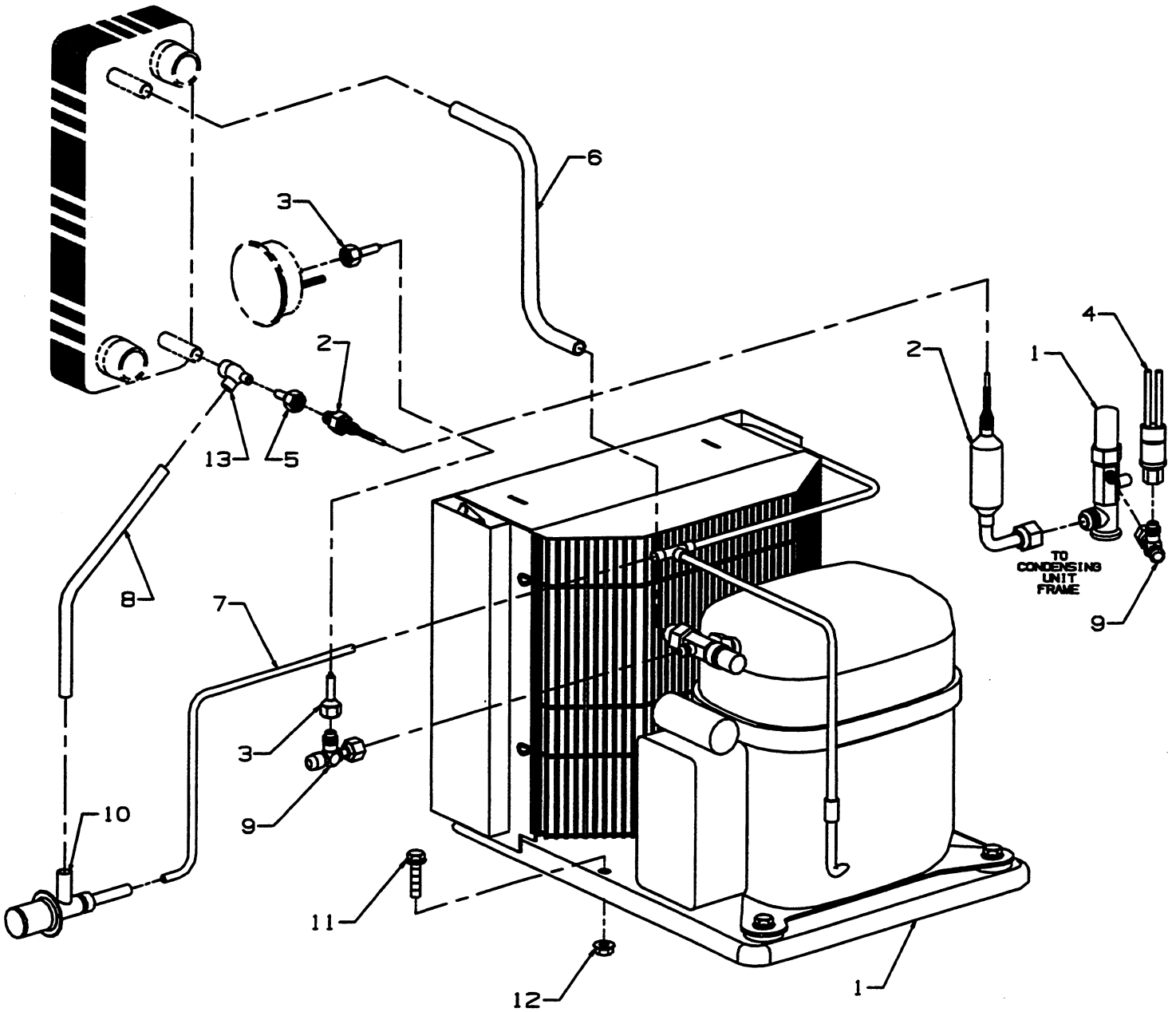

# ILLUSTRATIONS AND PARTS LIST

---

## 7.5 REFRIGERANT SYSTEM – SRD 105

<i>key number</i>	<i>description</i>	<i>part number</i>	<i>quantity</i>
1	unit, cond .5HP/.37KW	Consult Factory	1
2	filter, dryer w/cap tube	02250058-535	1
3	line, gauge 1/4" flare x 30" long	250022-040	1
4	switch, press fan cut-out	02250058-534	1
5	nut, access assy	250033-737	1
6	tubing, 3/8" refer line	02250061-591	1
7	tubing, 1/4" refer line	02250061-593	1
8	tubing, 3/8" refer line	02250061-592	1
9	valve, access tee 1/4"	250032-322	2
10	valve, hot gas	02250058-536	1
11	screw, serr 5/16" x 1"	829705-100	2
12	nut, serr 5/16"	825305-283	2
13	tee, sldr 1/2" x 1/4" x 3/8"	805508-046	1

---

PLEASE NOTE: WHEN ORDERING PARTS, ALWAYS INDICATE SERIAL NUMBER OF DRYER UNIT.

# ILLUSTRATIONS AND PARTS LIST

## 7.6 ELECTRICAL SYSTEM – SRD 40

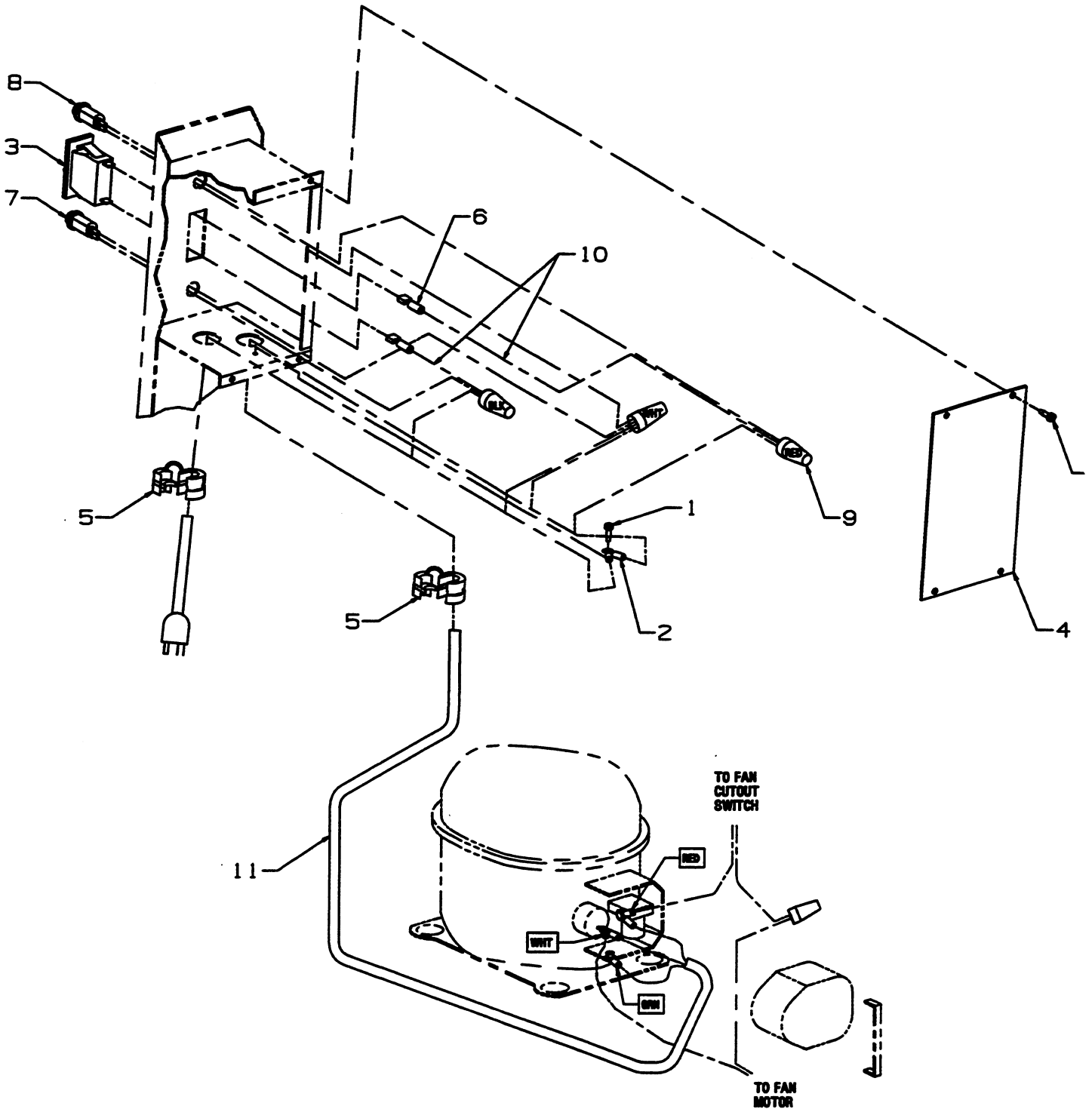

# ILLUSTRATIONS AND PARTS LIST

---

## 7.6 ELECTRICAL AND CONTROLS SYSTEM – SRD 40

<i>key number</i>	<i>description</i>	<i>part number</i>	<i>quantity</i>
1	screw, tc-f pan #8-32 x 1/2"	835601-050	5
2	terminal, ring #10 x 14-18 ga.	849302-014	6
3	switch, on/off 15 amp – 115v	250022-358	1
4	cover, enclosure SRD25 – 105	250032-917	1
5	bushing, straight thru strn	250034-496	2
6	disconn, self insul 14-16 ga.	849516-250	2
7	light, ind red neon-shapmount	406440	1
8	light, ind grn neon-shapmount	406440-001	1
9	connector, wire orange	851000-073	4
10	wire, mtw/awm 16 ga. black	850210-016	1 ft.
11	wire, cable 4-cond 18/4	250034-497	3 ft.

---

**PLEASE NOTE: WHEN ORDERING PARTS, ALWAYS INDICATE SERIAL NUMBER OF DRYER UNIT.**

# ILLUSTRATIONS AND PARTS LIST

## 7.7 ELECTRICAL SYSTEM – SRD 105

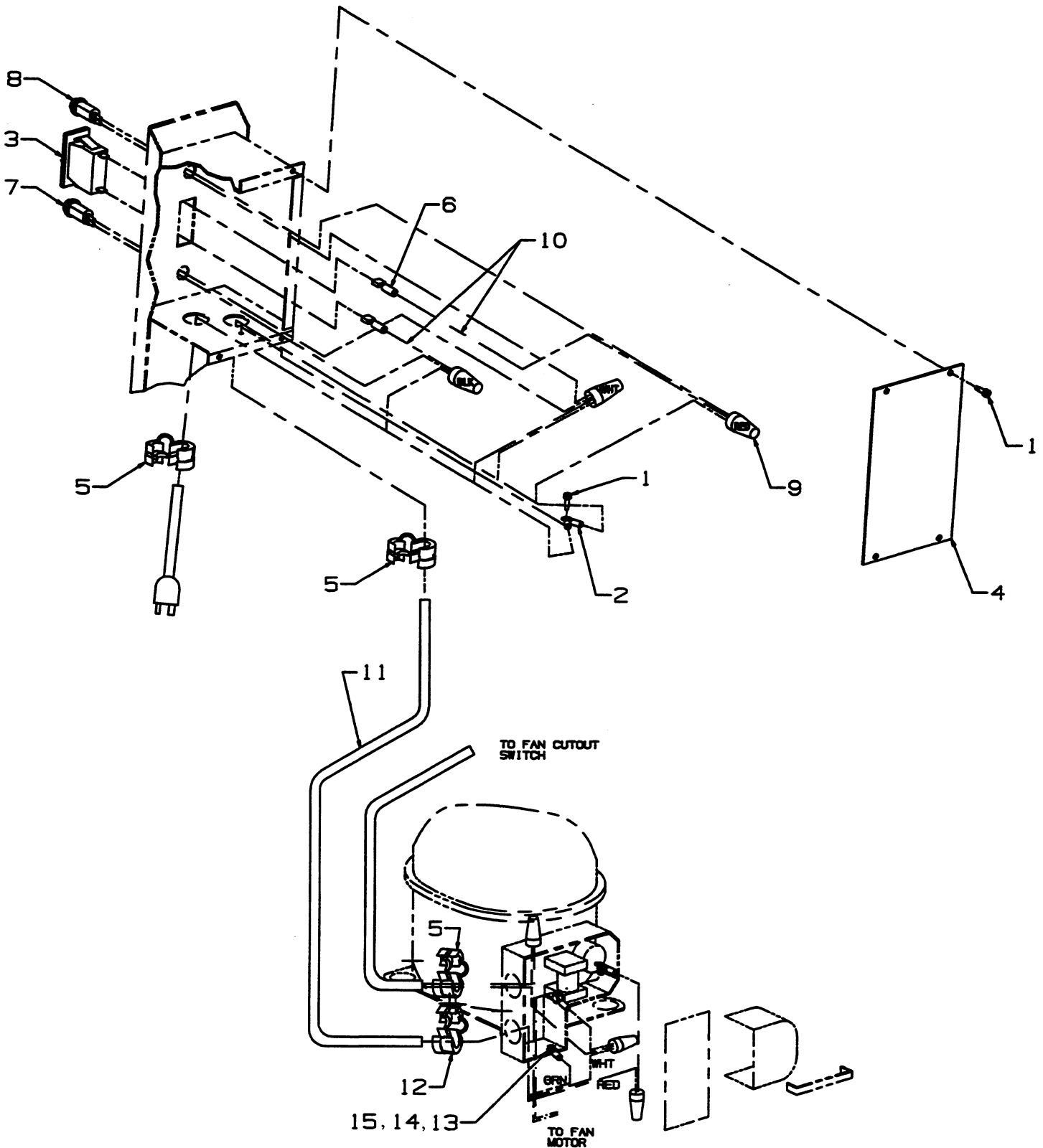

# ILLUSTRATIONS AND PARTS LIST

---

## 7.7 ELECTRICAL AND CONTROLS SYSTEM – SRD 105

<i>key number</i>	<i>description</i>	<i>part number</i>	<i>quantity</i>
1	screw, tc-f pan #8-32 x 1/2	835601-050	5
2	terminal, ring #10 x 14-18 ga.	849302-014	6
3	switch, on/off 15 amp-115v	250022-358	1
4	cover, enclosure srd25 - 105	250032-917	1
5	bushing, straight thru strn	250034-496	3
6	disconn, self insul 14-16ga	849516-250	2
7	light, ind red neon-shapmount	406440	1
8	light, ind grn neon-shapmount	406440-001	1
9	connector, wire orange	851000-073	4
10	wire, mtw/awm 16ga black	850210-016	1 ft.
11	wire, cable neoprene 16-3	850603-016	3
12	bushing, strait thru .43 od wire	02250061-441	1
13	screw, mach rd hd #10-24	831602-038	1
14	nut, hex #10-24	825202-130	1
15	washer, lock ext #10	838402-025	2

---

**PLEASE NOTE: WHEN ORDERING PARTS, ALWAYS INDICATE SERIAL NUMBER OF DRYER UNIT.**

# ILLUSTRATIONS AND PARTS LIST

## 7.8 FRAME, CANOPY AND PARTS – SRD 40 & 105

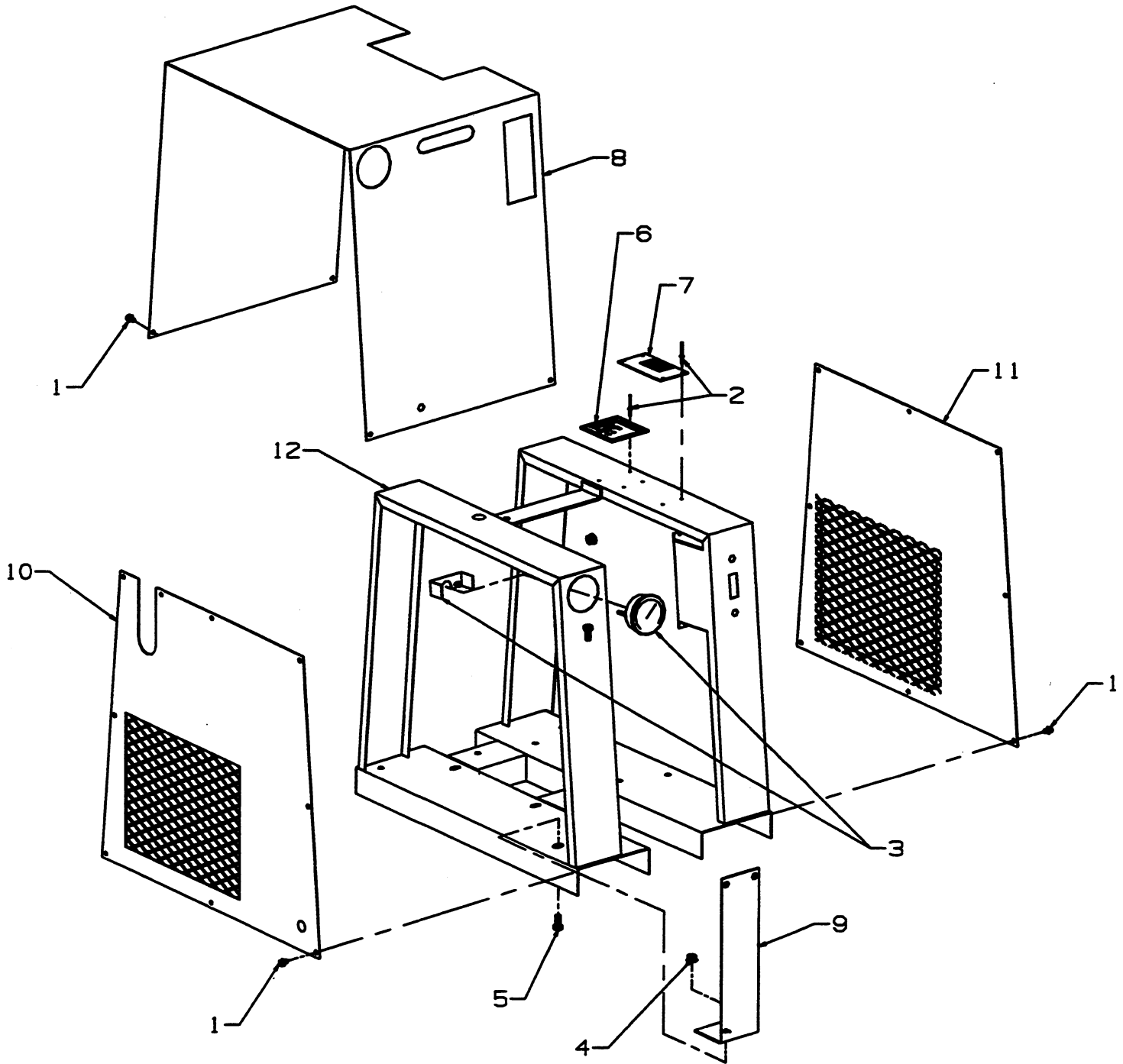

# ILLUSTRATIONS AND PARTS LIST

---

## 7.8 FRAME, COVER AND PARTS – SRD 40 & 105

<i>key number</i>	<i>description</i>	<i>part number</i>	<i>quantity</i>
1	screw, self-drill 1/4" x 1/2"	834504-050	21
2	rivet, pop 1/8" x 1/2"	843102-050	6
3	gauge, pressure suction – freon	02250046-815	1
4	nut, hex female 3/8" – 16	825306-347	1
5	capscrew, hex gr5 3/8" – 16 x 3/4"	808606-075	1
6	nameplate, PSII, PDC, SRD	250031-936	1
7	nameplate, serial number	Consult Factory	1
8	canopy, cover	250032-883	1
9	support, evaporator	250032-920	1
10	panel, canopy left	250032-915	1
11	panel, canopy right	250032-916	1
12	frame, assembly	250032-884	1

---

**PLEASE NOTE: WHEN ORDERING PARTS, ALWAYS INDICATE SERIAL NUMBER OF DRYER UNIT.**

# Section 7 ILLUSTRATIONS AND PARTS LIST

## 7.9 PIPING & INSTRUMENTATION – SRD 40

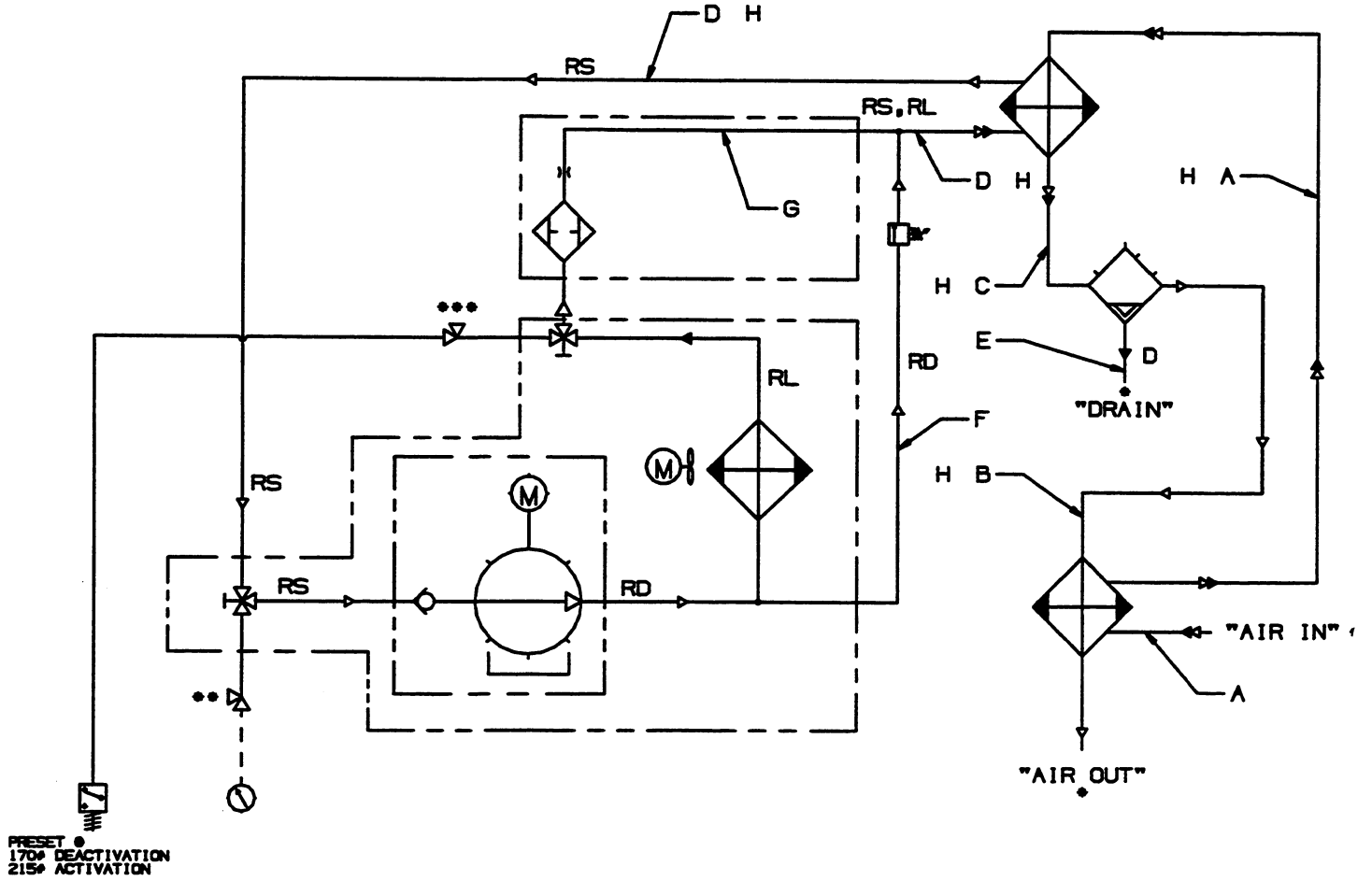

- NOTE:
1. • -CUSTOMER CONNECTION
  2. •• -ACCESS PORTS FOR SERVICE PRESSURE GAUGE
  3. •••-ACCESS PORT
  4. PART NUMBERS ARE FOR REFERENCE ONLY, REFER TO BOM AND/OR FACE OF ORDER FOR ACTUAL PARTS.
  5. FAN SWITCH PRESET @ 215° ACTIVATION  
170° DEACTIVATION

LINE SIZE AND MATERIAL SCHEDULE		LEGEND	
LETTER	LINE SIZE AND MATERIAL		
A	1" SCHEDULE 40 BLACK PIPE	REFRIGERANT DISCHARGE - RD	→
B	1" STEEL TUBING	REFRIGERANT LIQUID - RL	→
C	3/4" SCHEDULE 40 BLACK PIPE	REFRIGERANT SUCTION - RS	→
D	3/8" COPPER TUBING	MOISTURE DRAIN - D	→
E	1/4" THERMOPLASTIC TUBING	CONTROL LINE	- -
F	1/4" COPPER TUBING		
G	COPPER CAPILLARY TUBE (.050" ID X .48")		
H	MUST BE INSULATED		

# Section 7 ILLUSTRATIONS AND PARTS LIST

## 7.10 PIPING & INSTRUMENTATION – SRD 105

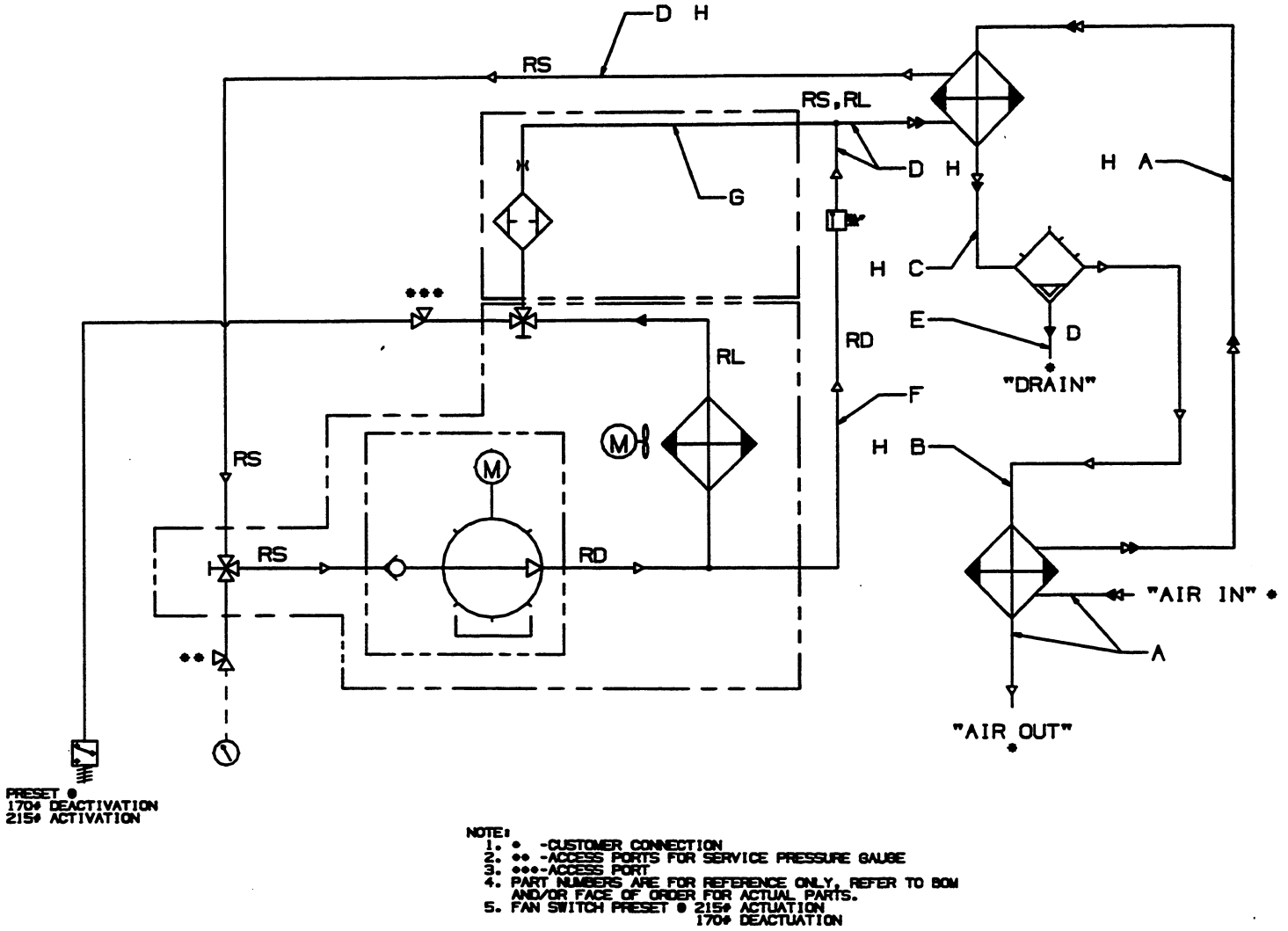

LINE SIZE AND MATERIAL SCHEDULE	
LETTER	LINE SIZE AND MATERIAL
A	1" SCHEDULE 40 BLACK PIPE
B	1" STEEL TUBING
C	3/4" SCHEDULE 40 BLACK PIPE
D	3/8" COPPER TUBING
E	1/4" THERMOPLASTIC TUBING
F	1/4" COPPER TUBING
G	COPPER CAPILLARY TUBE (.055" ID X 48")
H	MUST BE INSULATED

LEGEND	
REFRIGERANT DISCHARGE - RD	→
REFRIGERANT LIQUID - RL	→
REFRIGERANT SUCTION - RS	→
MOISTURE DRAIN - D	→
CONTROL LINE	- -

# ILLUSTRATIONS AND PARTS LIST

## 7.11 DECAL GROUP

**NORMAL OPERATING CONDITIONS**

<b>REFRIGERANT 12</b>	<b>REFRIGERANT 22</b>
<b>REFRIGERANT SUCTION PRESSURE</b>	<b>REFRIGERANT SUCTION PRESSURE</b>
<b>31 TO 35 PSIG</b>	<b>59 TO 65 PSIG</b>
IF DIFFERENT FROM NORMAL, ADJUST HOT GAS BYPASS VALVE TO RETURN TO NORMAL, SEE MANUAL. ADD 1 PSIG TO MINIMUM SUCTION PRESSURE PER 2000 FT. OF ALTITUDE.	
<b>REFRIGERANT HEAD PRESSURE</b>	
<b>AIRCOOLED</b>	<b>AIRCOOLED</b>
<b>181 PSIG MAX.</b>	<b>296 PSIG MAX.</b>
IF HEAD PRESSURE REMAINS CONSISTENTLY ABOVE NORMAL READINGS, REFER TO THE TROUBLE SHOOTING SECTION OF YOUR OPERATORS MANUAL.	
<b>IMPORTANT</b> FOR SRD 300-3100. ENERGIZE CRANKCASE HEATER (12) TWELVE HOURS PRIOR TO STARTING THE DRYER. (I.E. POWER TO THE LINE SIDE TERMINALS OF STARTER). FAILURE TO FOLLOW ABOVE INSTRUCTIONS MAY VOID WARRANTY.	
02250046-916	

**⚠ DANGER**



**Lethal shock hazard inside.**

**Disconnect all power at source, before opening or servicing.**

**⚠ DANGER**



**Death or serious injury can occur from inhaling compressed air without using proper safety equipment.**

**See OSHA standards on safety equipment.**

250027-935

**⚠ WARNING**



**Use equipment grounding connector in accordance with the National Electrical Code, and all Federal, State, and Local Codes, to help avoid possible ground fault shock hazard.**

**⚠ WARNING**



**Do not permit air from this equipment to contact food stuff except in full compliance with FDA Standard 21CFR178.3570, and all other applicable federal, state and local, codes, standards and regulations.**



**ILLUSTRATIONS AND PARTS LIST**

---

**7.11 DECAL GROUP**

<i>key number</i>	<i>description</i>	<i>part number</i>	<i>quantity</i>
1	decal, SRD normal open cond.	02250046-916	1
2	sign, danger electrocution	049850	1
3	decal, danger breathing	250027-935	1
4	decal, Sullair with logo	250031-360	2
5	sign, warning ground fault	049852	1
6	sign, warning "food grade" lube	250003-144	1

---

**PLEASE NOTE: WHEN ORDERING PARTS, ALWAYS INDICATE SERIAL NUMBER OF DRYER UNIT.**

# Section 7 ILLUSTRATIONS AND PARTS LIST

## 7.11 DECAL GROUP



7

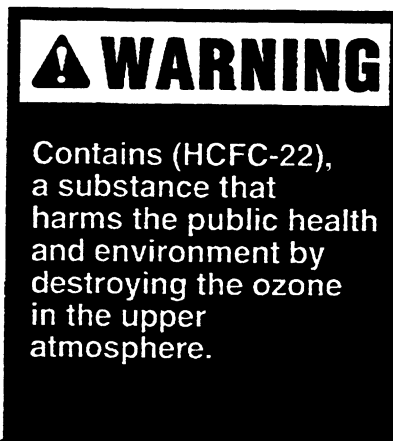

8

02250054-320

9

RUN	POWER	DRAIN	HOT GAS BYPASS VALVE
AIR INLET	AIR OUTLET	START	THERMAL EXPANSION VALVE
REFRIGERANT HEAD PRESSURE	REFRIGERANT SUCTION PRESSURE	STOP	250031-275



10

**ILLUSTRATIONS AND PARTS LIST**

---

**7.11 DECAL GROUP**

<i>key number</i>	<i>description</i>	<i>part number</i>	<i>quantity</i>
7	sign, warning sever fan port	049965	1
8	decal, wrn HCFC 22	02250054-320	1
9	decal, controls kit SRD	250031-275	1
10	decal, ISO 9001 (black)	02250057-624	1

---

**PLEASE NOTE: WHEN ORDERING PARTS, ALWAYS INDICATE SERIAL NUMBER OF DRYER UNIT.**

# ILLUSTRATIONS AND PARTS LIST

7.12 WIRING DIAGRAM – SRD 40

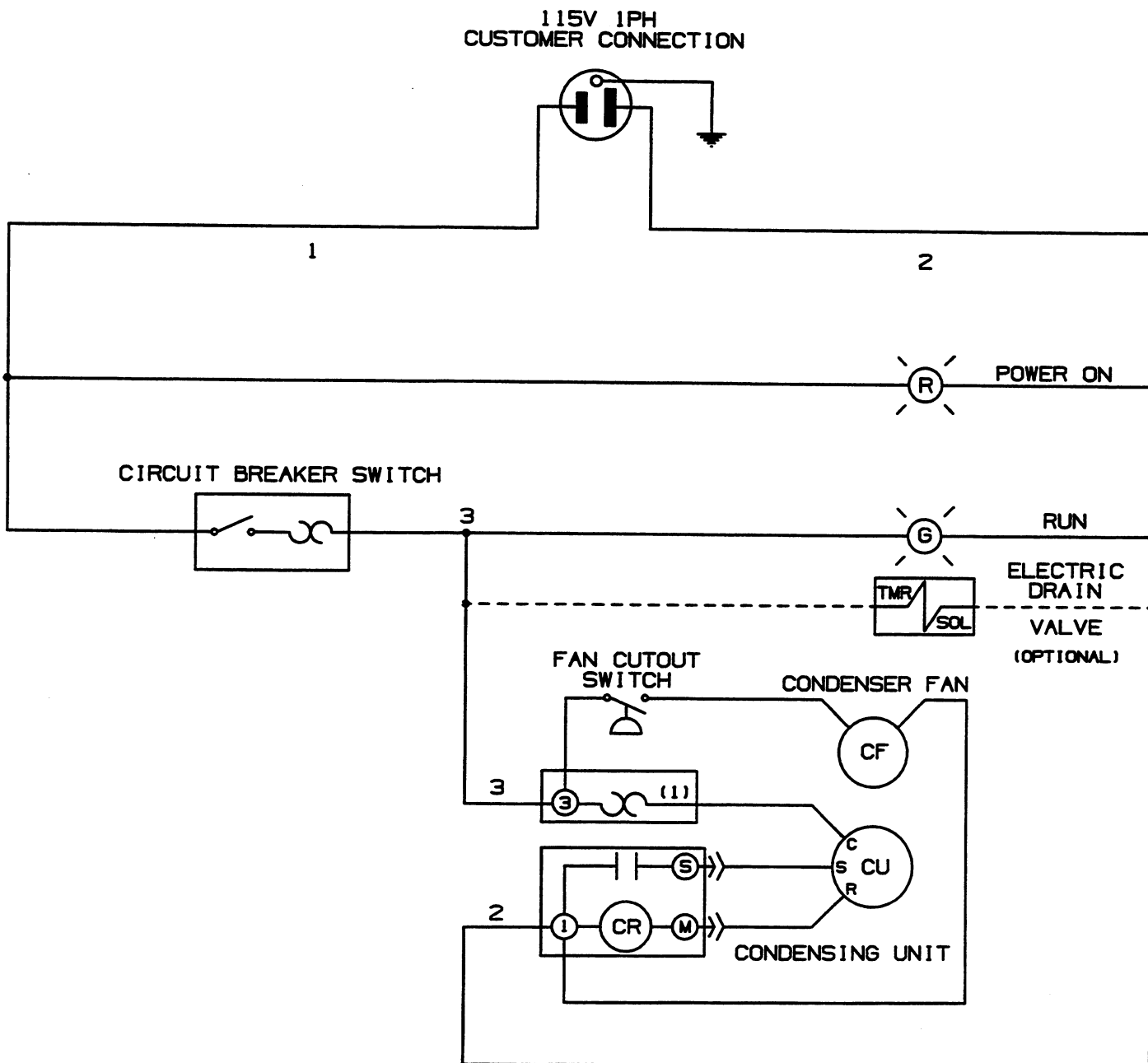

# ILLUSTRATIONS AND PARTS LIST

7.13 WIRING DIAGRAM – SRD 105

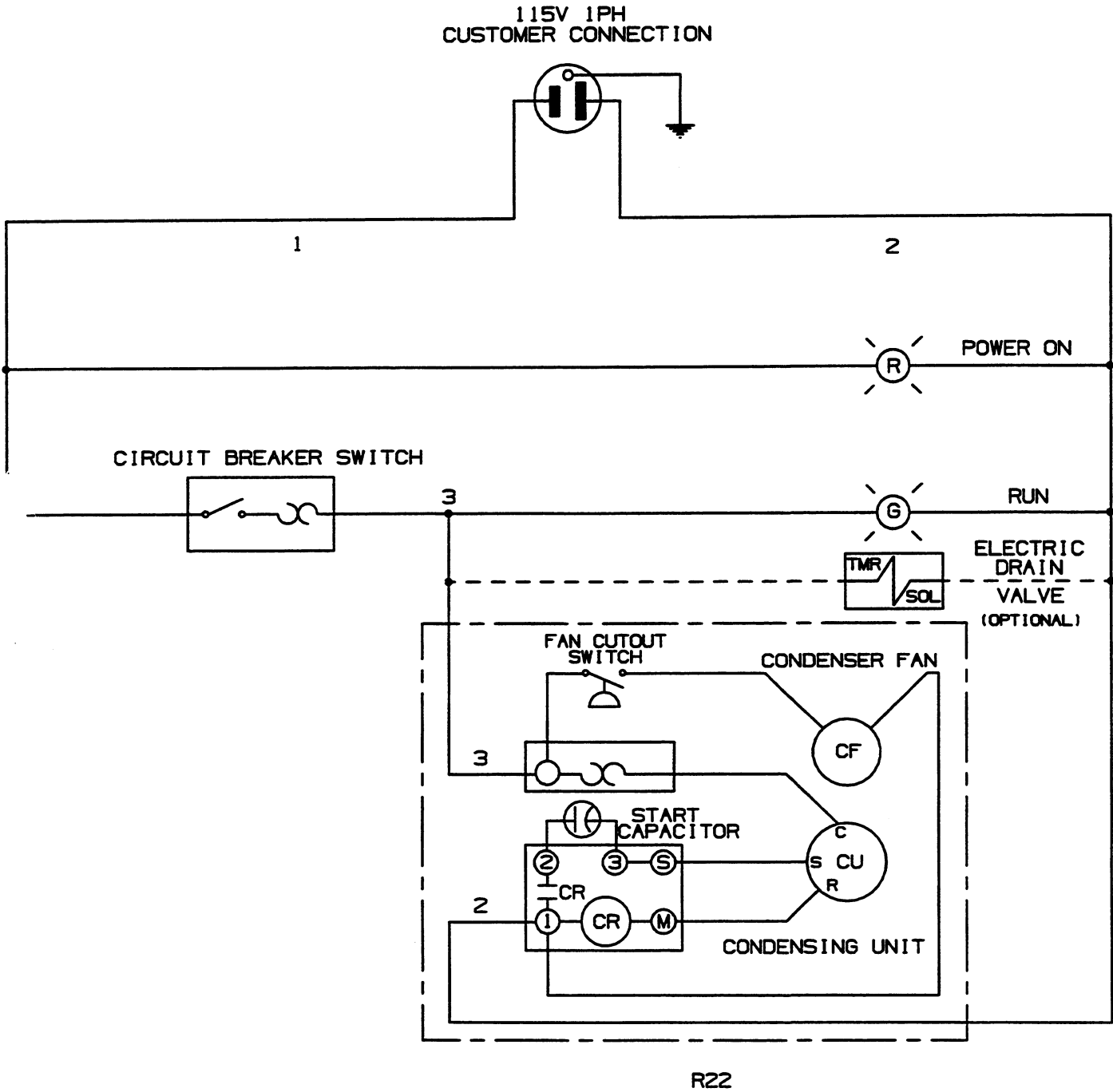





# WORLDWIDE SALES AND SERVICE

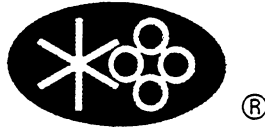

**SULLAIR ASIA, LTD.**  
ROOM 2304A  
Shartex Plaza Ctr.  
No. 88 Zun Yi Nan Rd.  
Shanghai, P.R.C.  
Telephone: 21-2192066  
FAX: 21-2196568

**SULLAIR EUROPE, S.A.**  
Chemin de Genas BP 639  
69800 Saint Priest, France  
Telephone: 33-72232425  
FAX: 33-78907168

**SULLAIR CORPORATION**  
Subsidiary of Sundstrand Corporation  
3700 East Michigan Boulevard  
Michigan City, Indiana 46360 U.S.A.  
Telephone: 1-800-SULLAIR (U.S.A. Only) or  
1-219-879-5451  
FAX: (219) 874-1273  
FAX: (219) 874-1835 (Parts)  
FAX: (219) 874-1805 (Service)

Printed in U.S.A.

Specifications Subject To  
Change Without Prior Notice