



**Refrigerated  
Air Dryer**

---

# **OPERATOR'S MANUAL**

## **Models 25-500**

---



**SULLAIR**

Subsidiary of Sundstrand Corporation

3700 E. Michigan Boulevard  
Michigan City, Indiana 46360

Phone: 1-800-348-2722

**P/N250041-222**

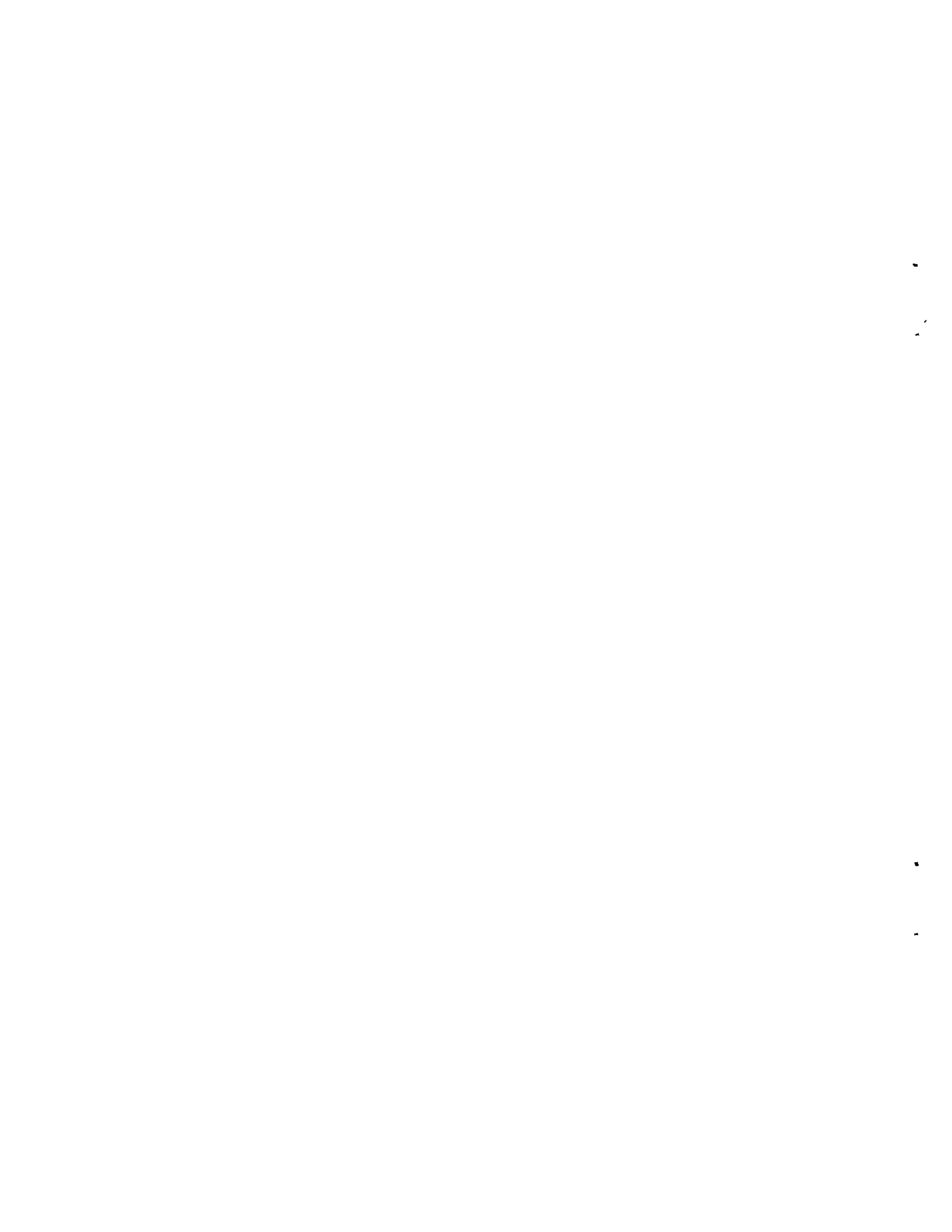



**Refrigerated  
Air Dryer**



KEEP YOUR MACHINE IN TOP  
OPERATING CONDITION  
USE

***GENUINE***

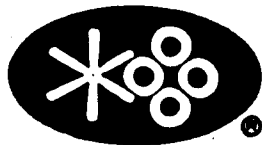

**SULLAIR®**

***SERVICE PARTS***

CONTACT YOUR NEAREST SULLAIR  
DISTRIBUTOR OR CALL 1-800-348-2722



**PURE-AIRE REFRIGERATED AIR DRYER  
(PDC)**

**TABLE OF CONTENTS**

FOREWORD .....	1
GENERAL INFORMATION .....	2-3
WARRANTY .....	4
RECEIVING AND INSPECTION .....	5
INSTALLATION .....	5-6
OPERATION .....	6-8
MAINTENANCE .....	8
TROUBLE-SHOOTING .....	8-12
SUGGESTED PIPING INSTALLATION .....	13
GENERAL ARRANGEMENTS .....	14-15
SYSTEM FLOW SCHEMATICS .....	16-18
WIRING DIAGRAMS .....	19-23
PARTS LISTS .....	24-25
SPECIFICATIONS .....	26
SERVICE RECORD .....	27



## FOREWORD

- A. This manual provides information and recommendations for installing, operating and servicing the Pure-Aire Refrigerated Air Dryer (PDC). The unit is designed and manufactured to the highest quality standards. All self-contained units have been fully tested and inspected by the manufacturer before shipment from the factory.
- B. The information, specifications and illustrations in this manual are in accord with the information in effect at the time of printing. The manufacturer reserves the right to change design and specifications without notice and without incurring obligations.
- C. It is extremely important to analyze completely every system and understand the intended function of each component before attempting to determine the cause of a malfunction or failure.
- D. The refrigerant (R-12 for PDC 25-400 and R-22 for PDC 500) and air circuit can be easily followed by referring to the schematic diagram.
- E. A refrigerant suction pressure and head pressure (for PDC 250 - 500) gauge is provided as standard equipment for analyzing the system operation and performance.
- F. Direct any question or problem not covered herein to the Sullair subsidiary from whom the unit was purchased, or Pure-Aire Inc. Always specify the **model** and **serial number** of the machine in all correspondence regarding service and parts.
- G. Parts can be ordered from your nearest Pure-Aire distributor. If for any reason parts cannot be obtained in this manner, contact the factory. Authorization and shipping instructions must be obtained from the factory before returning the parts to the factory (Pure-Aire, Inc.). The manufacturer will not be responsible for parts returned without proper authorization or identification.

## GENERAL INFORMATION

The Pure-Aire Refrigerated Air Dryer (PDC) is designed for the purpose of removing moisture from compressed air by cooling to a temperature of 35°F/39°F or 50°F.

### PRINCIPLE OF OPERATION

(Refer to schematic diagram)

#### A) REFRIGERANT CIRCUIT:

Refrigerant is cycled through a close-loop system with two basic sections commonly referred to as; high and low pressure sections. The circuit leaving the capillary tube (PDC 25-150) /thermostatic expansion valve (PDC 250-500) to the evaporator (refrigerant-to-air heat exchanger) and to the compressor inlet is known as the low pressure or suction side. The circuit leaving the refrigerant compressor to the aircooled condenser, to the receiver, filter drier, expansion device and the hot gas bypass valve is called the high pressure or discharge side.

The compressor increases the pressure and temperature of the low pressure refrigerant gas drawn from the evaporator (an isentropic process), and discharges it into an air-cooled condenser. In the condenser, heat is removed from the refrigerant gas thereby condensing into a saturated liquid at constant pressure. The high pressure liquid refrigerant will then flow into the receiver, and filter drier (which prevent plugging of the expansion device due to the retention scale, dirt, moisture, etc.)

For PDC 25-150, immediately after the filter drier is the capillary tube, which controls the flow of the refrigerant into the evaporator by the pressure differential across the device.

After the filter drier in the PDC 250-500, the refrigerant will flow through the sight glass/moisture indicator and into the thermostatic expansion valve which controls the flow of the liquid refrigerant by the degree of superheat of the suction gas. Both of these expansion devices reduce the pressure and temperature of the refrigerant causing it to partially vaporize until it is at the saturation temperature corresponding to its reduced pressure. In any case, the flow of refrigerant into the evaporator normally increases, as the evaporator load increases. Before the low pressure and temperature refrigerant will enter into the evaporator, a portion of the high pressure and temperature refrigerant taken between the compressor discharge and the condenser inlet is diverted through a hot gas bypass valve into the evaporator inlet. The primary advantage of this method is that, the thermostatic expansion valve will respond to the increased superheat of the vapor leaving the evaporator and will provide the liquid required for desuperheating. Also, the evaporator serves as an excellent mixing chamber for the bypassed hot gas

and the liquid-vapor mixture from the expansion device (capillary tube/thermostatic expansion valve). This ensures a dry vapor reaching the compressor suction. Oil return from the evaporator is also improved since the velocity in the evaporator is kept high by the hot gas.

As the liquid-vapor mixture enters the evaporator, it absorbs the heat (at constant pressure) from the compressed air causing the boiling action to continue until it is completely vaporized. The compressor takes in the low pressure and temperature refrigerant vapor for another cycle.

#### B) COMPRESSED AIR CIRCUIT:

##### **PDC 25**

This unit uses an air-to-refrigerant heat exchanger (evaporator) only, as a device to remove moisture from the compressed air. As the warm, saturated, compressed air enters the evaporator, it rejects the heat resulting in condensation of the moisture present in the air, and the reduction of temperature to the required pressure dewpoint.

The cold air then flows through a filter/separator where the condensate is discharged through the automatic, float-type drain trap.

##### **PDC 50-500**

The compressed air drying circuit uses an air-to-air heat exchanger which acts as a precooler/reheater, and an air-to-refrigerant heat exchanger (evaporator).

Warm, saturated, compressed air first enters the air-to-air heat exchanger, where it is precooled. By precooling the incoming air, energy is saved through the reduction of the heat load imposed on the refrigerant compressor and condenser. From the precooler, the air will enter into the evaporator further reducing its temperature to a desired pressure dewpoint of 35°F/39°F or 50°F. As the air is cooled to the required pressure dewpoint, moisture is condensed, where it is separated by a cyclone separator and discharged through an automatic, float-type drain trap.

The chilled air then re-enters the air-to-air heat exchanger, where it is reheated. Reheating of the air does not affect the air's dewpoint. It prevents condensation of moisture on the outside of the air-distribution piping. The cold air flows through the air-to-air heat exchanger in a direction opposite to the flow of the warm, saturated incoming air. This counterflow action assures high temperature differential throughout the heat exchanger, resulting in a more effective heat transfer.

## PURE-AIRE WARRANTY

All Pure-Aire products (with the exception of PDC's and POV's) are warranted to be free from defective materials and workmanship for a period of twelve months from date of installation, not to exceed fifteen months from date of shipment from our factory. Any equipment, material or part proving so defective will be replaced free of charge, (F.O.B. our plant) provided that within the above stated time limits Pure-Aire is notified of the alleged defect and that should Pure-Aire authorize return of such parts they be returned to Pure-Aire, Charlotte, NC; freight prepaid within 30 days after such authorization.

Components furnished to Pure-Aire by third parties, such as electric motors, refrigerant compressors, heat exchangers and controls are warranted only to the extent of the original manufacturer's warranty to Pure-Aire.

THIS STATEMENT OF WARRANTY IS EXPRESSLY IN LIEU OF AND DISCLAIMS ALL OTHER EXPRESS WARRANTIES, IMPLIED WARRANTIES OF MERCHANTABILITY AND ALL OTHER IMPLIED WARRANTIES. THERE ARE NO WARRANTIES WHICH EXTEND BEYOND THE DESCRIPTION ON THE FACE HEREOF. THIS WARRANTY DOES NOT INCLUDE LIABILITY FOR CONSEQUENTIAL DAMAGES. THIS WARRANTY DOES NOT APPLY TO ANY UNIT DAMAGED BY ACCIDENT, MISUSE OR NEGLIGENCE.

All claims under this warranty should be made by contacting the Sullair distributor who sold the machine (or the factory) describing the malfunction. A service technician will then be provided by Pure-Aire or our distributor or Pure-Aire may authorize procurement of the services of a competent local refrigeration service company. Unauthorized claims will be disallowed.

PDC's are warranted as above, except that a service technician will only be provided by Pure-Aire within a 6 month period from date of shipment. POV drain valves are warranted to be free from defects in materials or workmanship for a period of 6 months from date of shipment. No Service Technician will be provided.

*OUTSIDE THE CONTINENTAL UNITED STATES, PUERTO RICO, OR CANADA, PURE-AIRE PRODUCTS ARE WARRANTED AS ABOVE EXCEPT THAT A SERVICE TECHNICIAN WILL NOT BE PROVIDED AT OUR EXPENSE.*

EFFECTIVE 1 MARCH 85

## RECEIVING AND INSPECTION

Each dryer is test run at the factory before shipment. **Immediately upon receipt of the equipment**, remove the cabinet and check the unit carefully for any physical damage that may have occurred in transit.

If there is any physical damage or a refrigerant leak, please file a claim with the shipper immediately and notify your Sullair subsidiary or the factory of the nature of the damage. The carrier is legally responsible for any damages, since the unit is shipped F.O.B. Charlotte, N.C. Your Sullair subsidiary or Pure-Aire will assist in every way possible to rectify any problems.

After you are assured that the unit has sustained no shipping damage, the dryer is ready for installation.

## INSTALLATION

### LOCATION:

The dryer should be installed in an area that is clean and dry, allowing sufficient space on all sides for routine maintenance and service. The unit should be shielded from direct sunlight as well as the weather elements, with ambient temperature above 40°F and not more than 100°F. Occasional operation at ambient temperature up to 120°F will not damage the dryer but will affect the capacity. Temperatures below 35°F can cause freeze-ups of the condensate drains. If prolonged periods below 35°F are expected, a heat source for these areas will have to be provided.

Sufficient ventilation must be provided to maintain acceptable ambient temperature for efficient operation.

PDC Refrigerated Air Dryers are designed to operate with saturated air at the inlet. They should be installed downstream of a functional after-cooler/separator combination to prevent slugging the dryer with liquid water.

### FOUNDATION:

Foundation should be any reasonable level and vibration-free floor sufficiently strong for supporting the total weight of the unit.

### PIPING:

Compressed air piping should be at least of equal size to that furnished on the inlet and outlet of the dryer. Larger pipes reduced to the inlet/outlet pipe size may be used. It is recommended that shut-off valves with unions be installed at each port, with a valved bypass to permit isolation of the unit for servicing and eliminate the need of shutting down the plant air system (Refer Suggested Piping Arrangement).

Make sure when piping is connected, that undue stress is not applied on the dryer fittings.

Drain lines should be sloped adequately to drain by gravity any water accumulated after separation. It must be connected directly to a proper disposal system.

## ELECTRICAL

The nameplate on the instrument panel of each unit identifies the power supply requirements. A suitable fused disconnect switch in compliance with the National and Local Electrical Code requirements is recommended.

The wiring of all functional electrical components has been completed at the factory in accordance with the electrical wiring schematic provided with this manual.

Connect the power supply lines to the electrical switch/circuit breaker terminal. The switch has circuit protection and a power indicating light. A fuse is connected on the primary side of the control transformer to protect the unit from overcurrent and short circuit. (PDC 250-500, 460V).

The compressor can rotate in either direction. The fans are single phase and will turn only in the correct direction (fan must pull air across the condenser).

*(NOTE: GROUNDING OF THE FRAME IS REQUIRED).*

## OPERATION

### BEFORE START-UP:

1. After the installation has been completed, the following items should be checked.
  - a) Check main electrical supply to insure correct voltage and fuse is provided.
  - b) Check proper connection and support of compressed air lines to the dryer (complete with bypass valving system).
  - c) Check that inlet air temperature and pressure to the dryer meets the specification requirements.
2. The gauge readings are as follows:
  - a) **REFRIGERANT SUCTION PRESSURE:** Indicates the refrigerant pressure as it enters the compressor. It is equivalent to the ambient temperature converted to pressure. (Example: At 70°F ambient temperature, R-12 suction pressure is 70.2 psig — See Temperature-Pressure Chart).

- b) **REFRIGERANT HEAD PRESSURE** (For PDC 250-500): Indicates the refrigerant pressure as it leaves the compressor. Same pressure reading as the suction pressure.
- c) **SIGHT GLASS AND MOISTURE INDICATOR** (For PDC 250-500): Indicates the condition of the refrigerant in the system (full, wet or dry).

#### START-UP:

- 1) For PDC 25-150, turn on the main disconnect and power switch to the dryer. The power indicating light will be on.  
For PDC 250-500, turn on the main disconnect switch to the dryer. **THE DRYER MUST BE IN THIS MODE FOR AT LEAST TWELVE (12) HOURS TO ALLOW THE COMPRESSOR CRANKCASE HEATER TO ENERGIZE.** After twelve (12) hours, turn on the power switch of the dryer. The power indicating light will be on.
2. Check that the bypass valve in the main air line is open and the shut-off valve to the dryer is closed.
3. Open the shut-off valve on the dryer inlet line gradually to pressurize the unit. When the dryer is up to pressure, check all pipework connections for leaks.
4. Open slowly the outlet shut-off valve and close the bypass valve.

#### RUNNING OPERATION:

1. After the dryer has been started under rated load, let the dryer run for at least 15 minutes to allow stabilization of the system.
2. The dryer is designed to run continuously and should not be cycled with the compressor.
3. The gauges reading are as follows:
  - a) **REFRIGERANT SUCTION PRESSURE.**  
R-12 (PDC 25-400) = 30-35 psig  
R-22 (PDC 500) = 60-65 psig
  - b) **REFRIGERANT HEAD PRESSURE:** Take the ambient temperature and add 25°F - 30°F; then convert to pressure using temperature-pressure chart.
  - c) **SIGHT GLASS AND MOISTURE INDICATOR** (For PDC 250-500): It may take up to 12 hours of running before the indicator becomes proper color indicating a dry system. Green color indicates a dry system. Yellow indicates a wet system. There should be no bubbles showing.

4. The non-cycling operation of the dryer is controlled by the capillary tube/thermostatic expansion valve and the hot gas bypass valve. These valves will open and close automatically depending on the amount of heat load to the evaporator, thus maintaining the desired pressure dewpoint of 35°F/39°F or 50°F.
5. The hot gas bypass valve and the thermostatic expansion valve are preset and do not need adjustment.
6. Observe the automatic drain trap to see what amount of condensate is being removed from the compressed air.

## MAINTENANCE

1. Check automatic condensate traps on a regular basis to insure that they are operating properly, or the emulsion will back up into the compressed air system. **Proper drain trap maintenance is owner's responsibility and not covered by warranty.**
2. The condenser fins may need to be periodically cleaned to remove dust, lint, etc., to assure efficient heat transfer. High head pressure or a visual check will confirm this condition.
3. Check the gauge readings periodically for good system operation.
4. For PDC 250-500, inspect sight glass and moisture indicator for a continuous stream of bubbles which indicates loss of refrigerant or color change from green to yellow indicating contamination.

## TROUBLE-SHOOTING

The dryer consists of three basic systems: AIR, REFRIGERANT AND ELECTRICAL. An air leak at 100 psig will provide an audible signal indicating where there is a problem. R-12 or R-22 has no color or odor therefore a small refrigerant leak is difficult to find. However, it can be detected by a bubble test, halide torch (with a flame which changes from red-orange to blue on contact with refrigerant), or an electronic detector.

The electrical system consists of transformers, starter, switches, relays, etc. The use of the volt-ohm meter or similar equipment is required for checking continuity, amperage and voltage.

PROBLEM	CAUSE	REMEDY	COMMENT
Unit does not run	No Line Voltage	Follow wiring diagram and check voltage from compressor terminal to the power source to find where the circuit was interrupted. Inspect electrical components such as switches, controls, motors, transformers, etc.	The supply power voltage, frequency and phase must coincide with the unit's nameplate.
	Improperly wired	Check wiring against wiring diagram and tighten any loose connection.	
	Blown fuse or tripped circuit breaker	Check for amperage draw of unit.	
	Safety controls open (for PDC 250-500)	Inspect the controls such as low and high pressure switches, and fan cut-out switch (if unit is equipped with one), and etc. to see if the contact points are closed.	The low pressure switch can shut down the unit due to loss of refrigerant or hot gas bypass valve being out of adjustment. The high pressure switch can shut down the unit due to high ambient air temp., condenser not receiving proper cooling, hot gas bypass valve out of adjustment, or overcharge of refrigerant.
Head pressure too high (for PDC 250-500)	Refrigerant overcharge	Discharge excess refrigerant. Check unit's nameplate for total system refrigerant charge.	Refrigerant overcharge may cause system not to perform properly and efficiently.
	Condenser fouled and dirty	Dismantle and clean condenser.	Clogged fins in air-cooled condenser will reduce heat transfer efficiency. Fins should be periodically checked and cleaned.

PROBLEM	CAUSE	REMEDY	COMMENT
Head pressure too high (for PDC 250-500)	Defective fan control (for PDC 250-500)	Repair or replace	For PDC 250-400 (R-12), fan control cuts in at 170 psig and cuts-out at 110 psig. For PDC 500 (R-22), fan control cuts-in at 275 psig and cut out at 195 psig.
	Defective Fan motor	Replace	
	Dryer location too hot (High Ambient)	Cool ambient or relocate the unit.	See Installation.
	Compressed air leaks to refr. system	Evacuate and recharge with refrigerant. Repair or replace evaporator.	Can be detected by checking the color indicator or bubbles in the glass.
	Fan operating in wrong direction	Reverse any two wires at disconnect. For single phase fans, replace the fan motor.	Single phase fans will rotate only in correct direction. Three phase fans check for proper rotation (wiring diagram). Fans must pull air thru condenser.
Head pressure too low (for PDC 250-500)	Low ambient temperature	Increase ambient temperature.	If ambient temp. is too low, excessive cooling will take place.
	Refrigerant shortage	Check for leaks in system, repair and recharge until bubbles disappear.	Turn off the unit for 5 mins. restart, watching sight glass. Bubbles should appear at first due to the modulating action of the expansion and hot gas bypass valve, then clear if system is full. If no bubbles appear, system has lost charge. See unit's nameplate for total system charge.
	Faulty compressor	Check for reason. Repair or replace.	If compressor valve, rings, etc. are defective, the unit will not compress and pump adequate refrigerant.
	Defective fan control (for PDC 250-500)	Repair, adjust or replace.	For PDC 250-400 (R-12), fan control cuts-in at 150 psig. and cut-out at 90 psig. For PDC 500 (R-22), fan control cuts-in at 230 psig. and cut-out at 150 psig.

PROBLEM	CAUSE	REMEDY	COMMENT
Suction pressure too low	Hot gas bypass valve out of adjustment, or defective	Adjust or replace.	Turn clockwise to increase suction pressure (R-12, 25 - 30 PSIG; for R-22 50-55 PSIG).
	Refrigerant shortage	Add enough refrigerant to maintain desired suction pressure.	Can be detected in the sight glass. Also check amperage draw.
	Thermostatic expansion valve does not feed enough refrigerant to evaporator	Adjust TXV by turning stem counterclockwise.	When adjusting the valve, make no more than one turn at a time, as much as 30 minutes may be required for the new balance to take place after adjustment is made.
	Excessive pressure drop in high side	Check for any restriction (plugged filter drier or receiver hand valve partially closed).	Suction pressure should be steady and vary only 1-3 PSIG from high to low at this condition.
Suction pressure too high	Hot gas bypass valve out of adjustment or defective	Turn counterclockwise to lower suction pressure to desired reading.	Compressed air dewpoint will rise as the suction pressure increases.
	Superheat too low or TXV is out of adjustment	Turn TXV clockwise.	Make sure that adjustment is made one full turn at a time and wait for about 30 mins. to stabilize.
	TXV bulb location	Relocate bulb making sure it is parallel to the direction of flow and of good thermal contact.	

PROBLEM	CAUSE	REMEDY	COMMENT
Water in the compressed air system.	Drain traps clogged	Disassemble and clean traps to restore free flow of drainage. Check drain lines.	Automatic drain traps are ballfloat type and do not need priming. It should be disassembled and cleaned after two weeks of operation. Open manual pet cock weekly, should more than one pint of fluid be discharged, clean traps thoroughly.
	Air by-pass system open	Close air bypass valve.	SEE START-UP
	Air flow rate exceeds the actual capacity of the dryer.	Check dryer capacity.	Air flowrate should meet dryer specification requirement.
	High inlet air temperature.	Check actual air temperature entering the dryer. It should meet specification requirement.	20°F increase in inlet air temperature will double the capacity of the air to hold water vapor.
High air pressure drop	Excessive air flow	Check SCFM through dryer.	
	Restricted air flow or leaks Evaporator frost up.	Check and repair.	Turn Dryer off for 20 to 30 min. while continuing to pass air thru unit. If pressure drop disappears adjust hot gas by-pass
Bubbles in sight glass	Refrigerant shortage	Check for leaks in system, repair and recharge with refrigerant until bubbles disappear.	The sight glass should be clear. The modulating action of the valves may cause a few bubbles during start-up but should clear up in 2-3 minutes.
Sight glass indicator changes to yellow. (For PDC 250-500)	Moisture in the system	Evacuate the charge, replace filter drier and recharge with refrigerant	
Frosting on capillary tubes (For PDC 25-150)	Capillary tubes plugged-up or undersize	Replace	

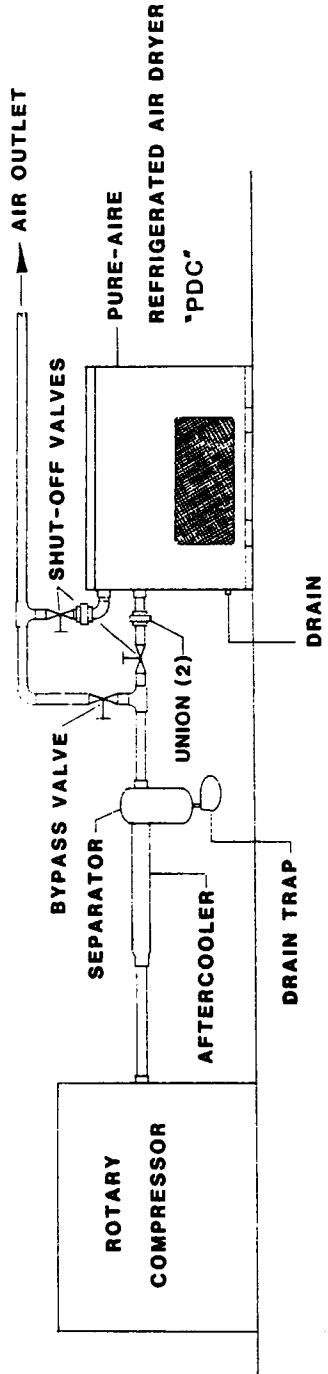

TYPICAL ROTARY COMPRESSOR AIR SYSTEM

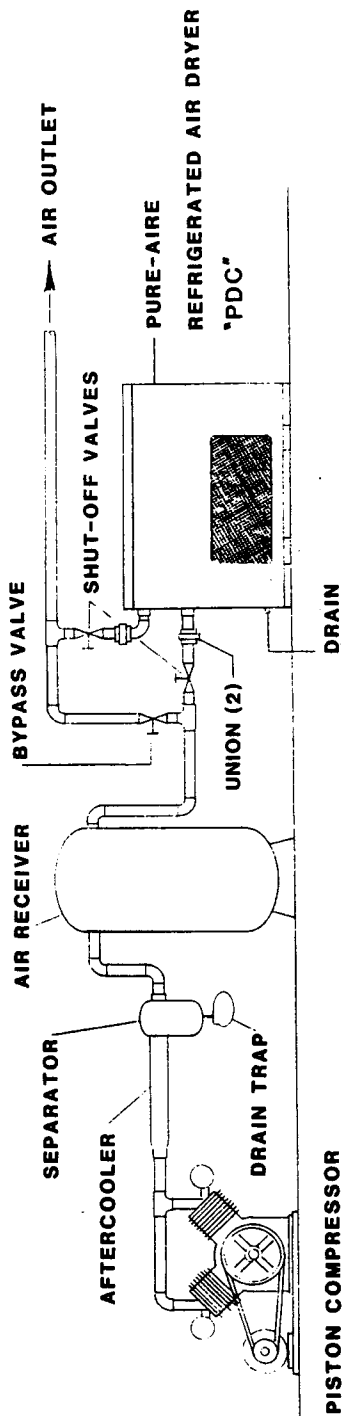

TYPICAL PISTON COMPRESSOR AIR SYSTEM

REV.	DATE	DESCRIPTION	BY
<small>INFORMATION ON THIS DWG. IS PROPERTY OF PURE-AIR, INC. AND NO TRANSFERS OR DISCLOSURES TO BE MADE WITHOUT PRIOR WRITTEN APPROVAL.</small>			
DATE: 7-12-84	SCALE	DRAWN BY: <i>[Signature]</i>	
TITLE: <b>SUGGESTED PIPING INSTALLATION</b>			
<b>8320</b>			DRAWING NUMBER: <b>601337</b>
PURE-AIR, INC. CHARLOTTE, N. C.			

UNION-CITY FURNACE, INC. CHARLOTTE, 1980



DUE TO MANUFACTURING TOLERANCES AND PARTS SELECTION, CONNECTION DIMENSIONS SHOWN ARE FOR REFERENCE ONLY AND SHOULD NOT BE USED FOR PRE-PIPING INSTALLATION

PDC MODEL	250	300	400	500
A	33	3 1/4	33	3 1/4
B	27	3 1/8	27	3 1/8

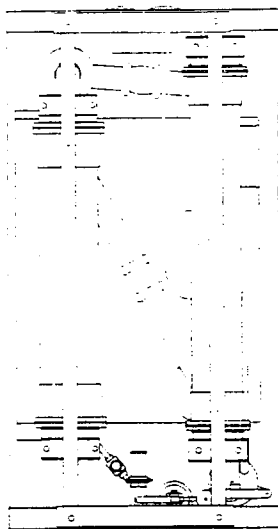
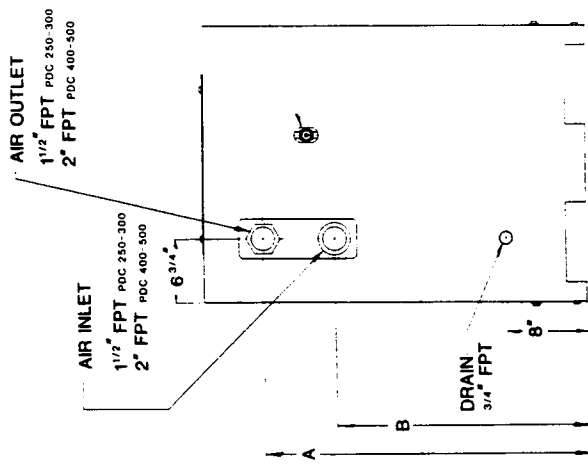

TOP VIEW

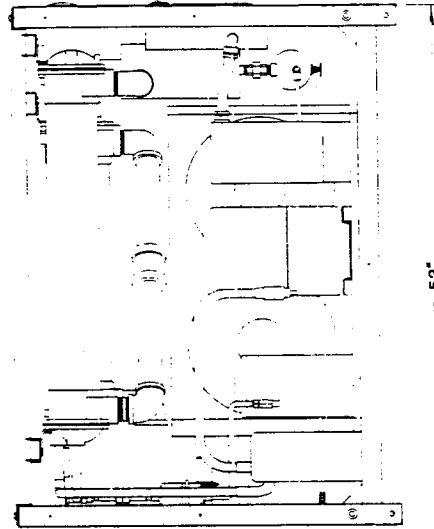

SIDE VIEW  
(CABINET NOT SHOWN)

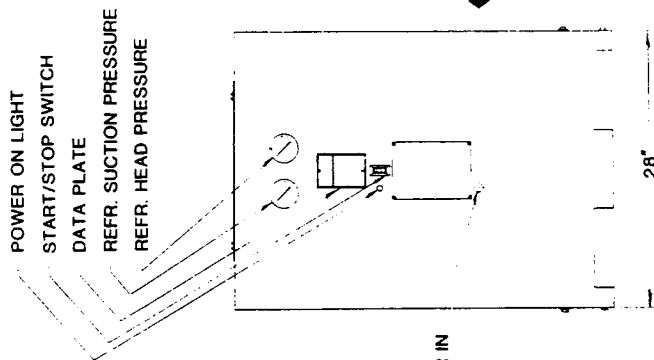

FRONT VIEW

H. MASSEY  
 3/12/85  
 PDC 250-500  
 GENERAL ARRANGEMENT  
 601329

4233

# REFRIGERATED AIR DRYER "PDC" MODEL

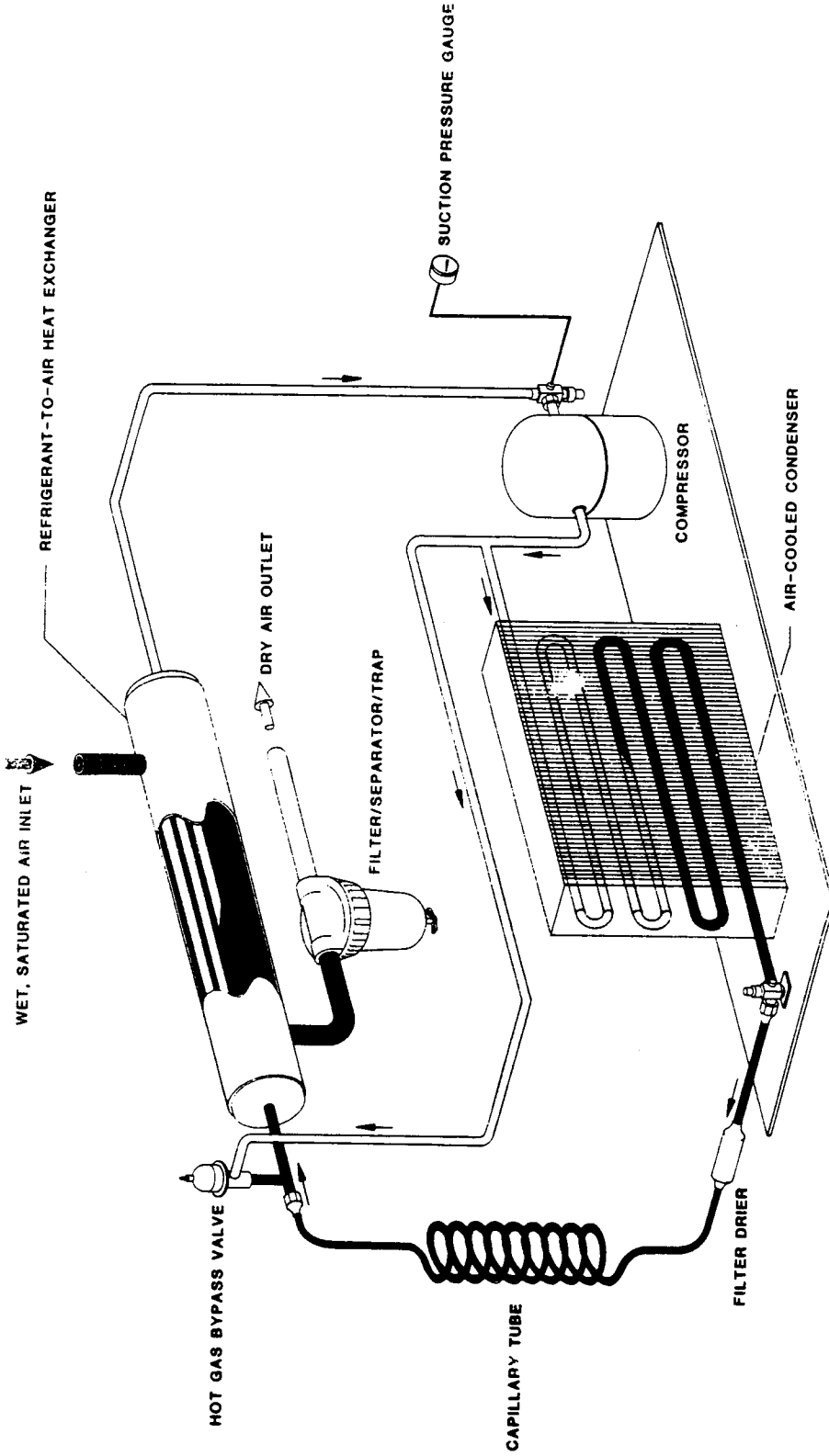

- LOW PRESSURE LIQUID
- LOW PRESSURE GAS
- HIGH PRESSURE GAS
- HIGH PRESSURE LIQUID
- WET, SATURATED AIR
- DRY AIR

PDC 25

DATE	DESIGNED BY	DR
REV	CHECKED BY	DR
APPROVED BY	DATE	9318

**FLOW SCHEMATIC**  
PURL AIR, INC.  
LITTLE ROCK, AR

004565

# REFRIGERATED AIR DRYER "PDC" MODEL

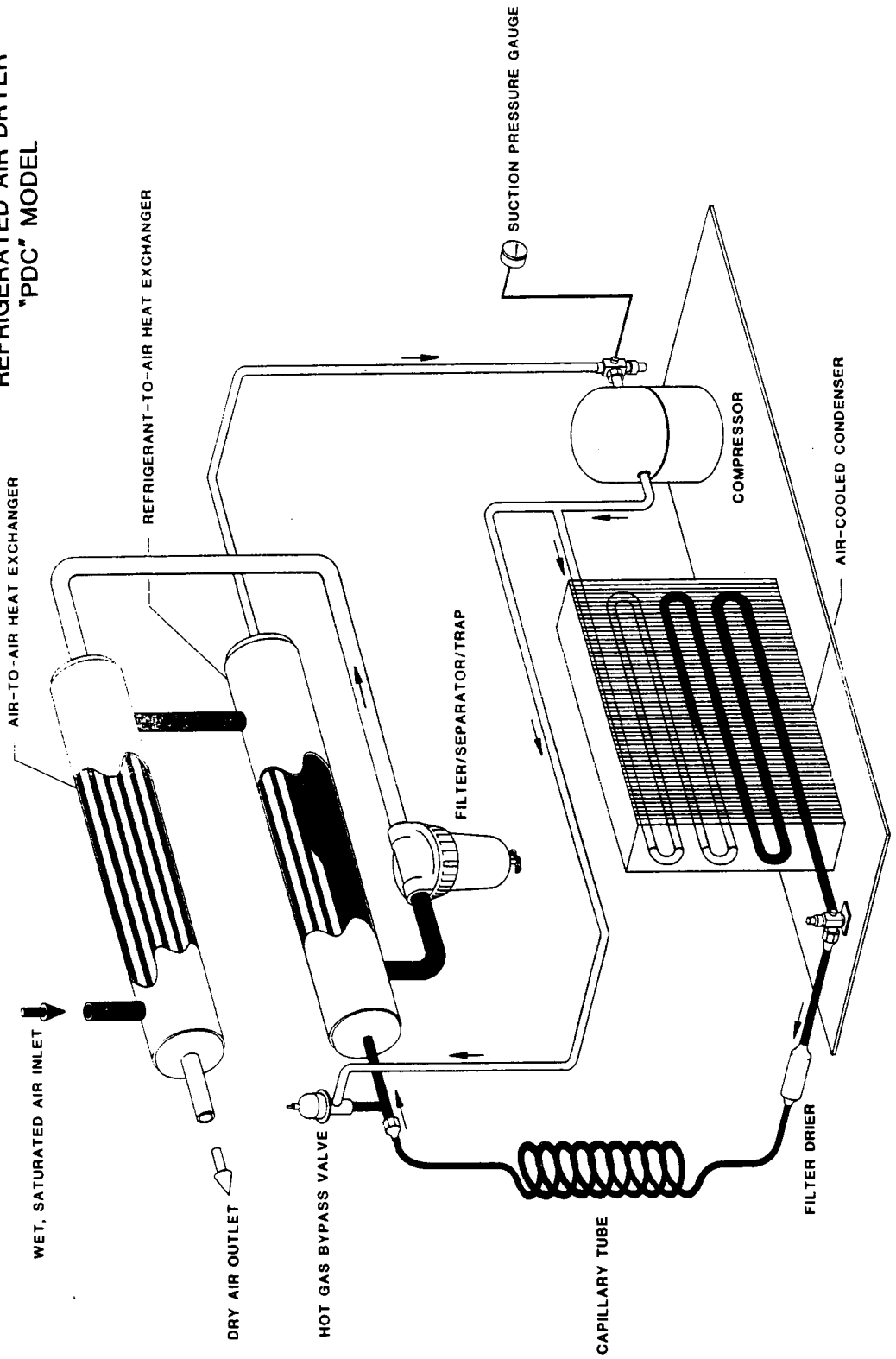

- LOW PRESSURE LIQUID
- LOW PRESSURE GAS
- HIGH PRESSURE GAS
- HIGH PRESSURE LIQUID
- WET, SATURATED AIR
- DRY AIR

PDC 50-150

REV	DATE	DESCRIPTION
<small>INFORMATION ON THIS DRAWING IS PROPERTY OF PURE-AIR, INC. AND WILL BE RETURNED TO THE DRAWER UPON REQUEST. THIS DRAWING IS NOT TO BE REPRODUCED OR TRANSMITTED IN ANY FORM OR BY ANY MEANS, ELECTRONIC OR MECHANICAL, WITHOUT PERMISSION IN WRITING FROM PURE-AIR, INC.</small>		
TITLE	DATE	DESIGNER
FLOW SCHEMATIC	2-21-85	B72
<small>PURE-AIR, INC. CHARLOTTE, N.C.</small>		<small>WORKING NUMBER 8317</small>

004564

PURE-AIR, INC. © 1985

# REFRIGERATED AIR DRYER "PDC" MODEL

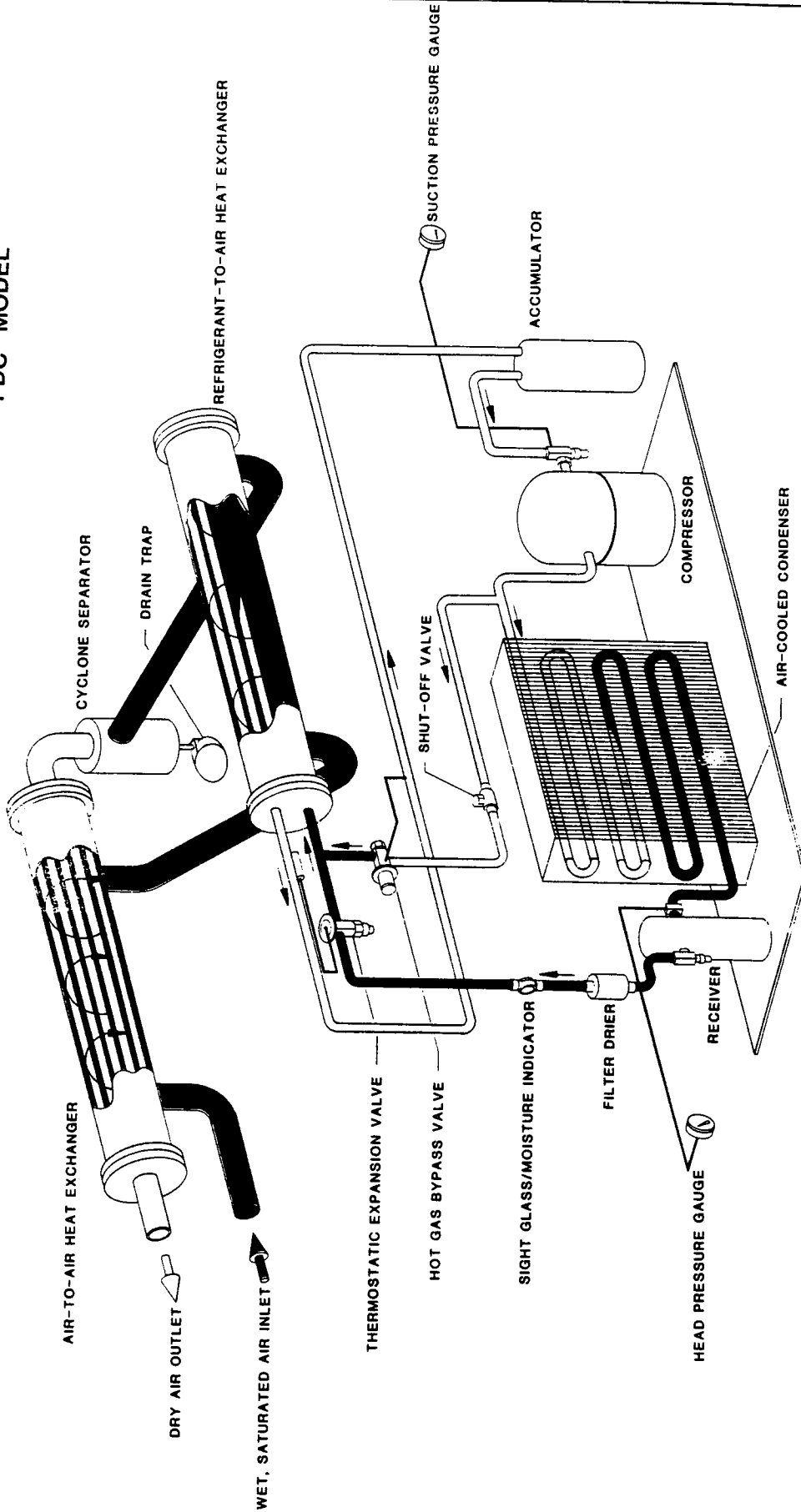

- LOW PRESSURE LIQUID
- LOW PRESSURE GAS
- ▨ HIGH PRESSURE GAS
- ▩ HIGH PRESSURE LIQUID
- ▧ WET, SATURATED AIR
- DRY AIR

PDC 250-500

REV	DATE	DESCRIPTION

INFORMATION ON THIS DRAWING IS PREPARED BY THE DESIGN DEPARTMENT OF PURE-AIR, INC. FOR THE USER'S INFORMATION. IT IS THE USER'S RESPONSIBILITY TO OBTAIN NECESSARY MATERIALS OR DISCREPANCIES TO BE MADE WITHOUT PURE-AIR WRITTEN APPROVAL.  
DATE: 1/27/55 BY: H.L.P. DRAWN BY: B.T.C.

**FLOW SCHEMATIC**  
 NUMBER: 1316  
 PURE-AIR, INC.  
 CHARLOTTE, N.C.

004563

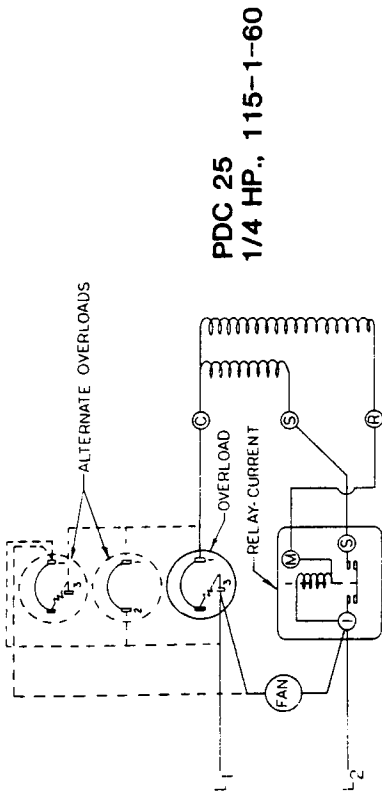

**PDC 25**  
1/4 HP., 115-1-60

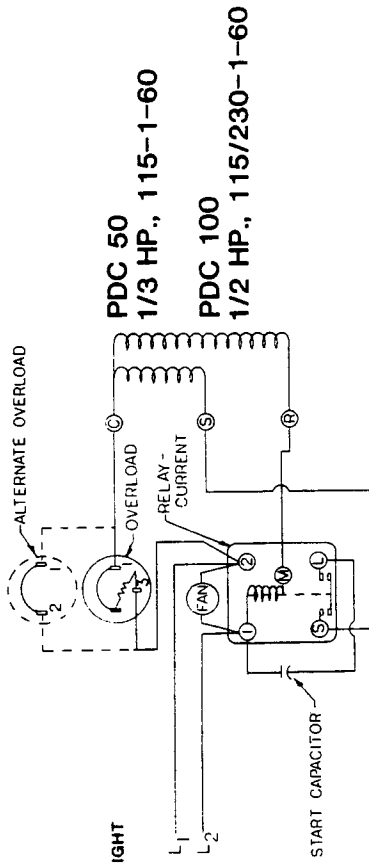

**PDC 50**  
1/3 HP., 115-1-60  
**PDC 100**  
1/2 HP., 115/230-1-60

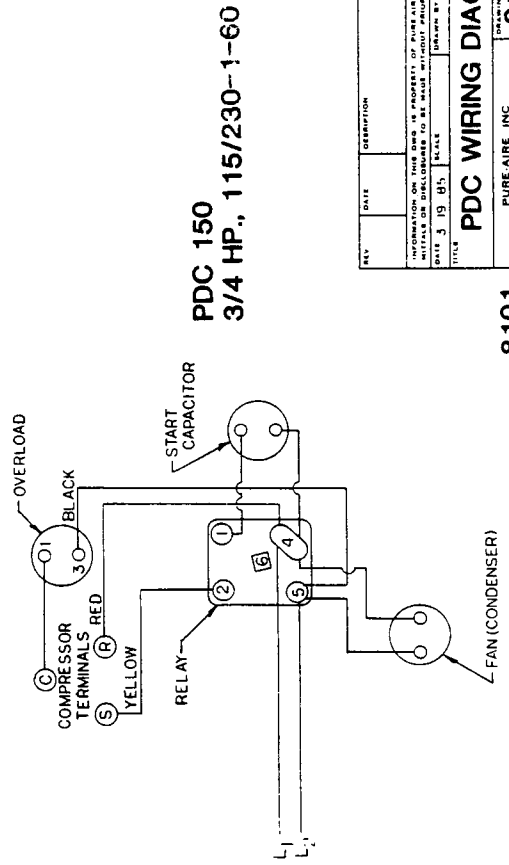

**PDC 150**  
3/4 HP., 115/230-1-60

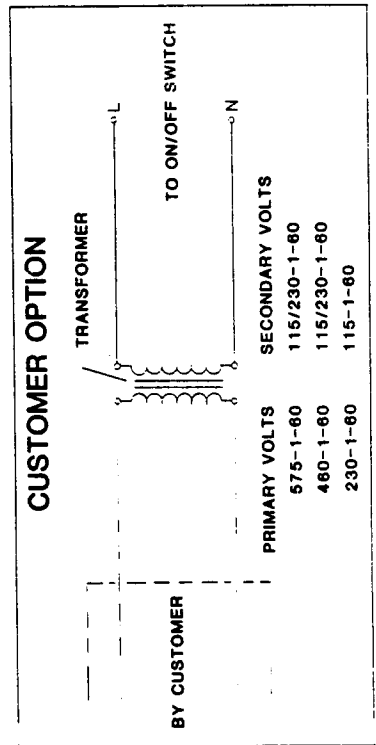
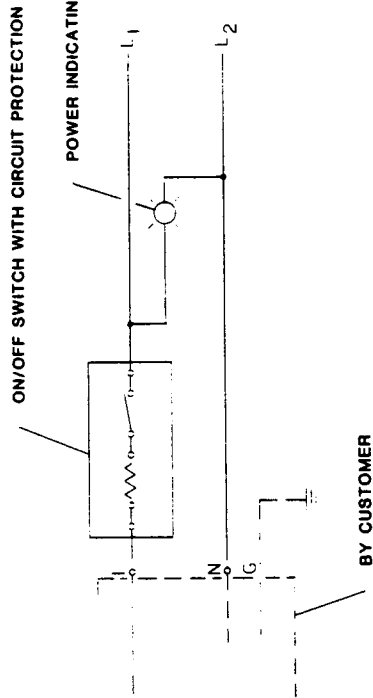

REV.	DATE	DESCRIPTION	BY
1	3 19 65	REVISED TO BE MADE WITHOUT PRIOR WRITTEN APPROVAL	P/L

**PDC WIRING DIAGRAM**

PURE-AIRE INC  
CHARLOTTE, N. C.

ORDERING NUMBER  
**019636**

PDC MODEL	RATED LOAD AMPS. 208-230/3/60
250	7.1
300	7.1
400	10.6
500	14.4

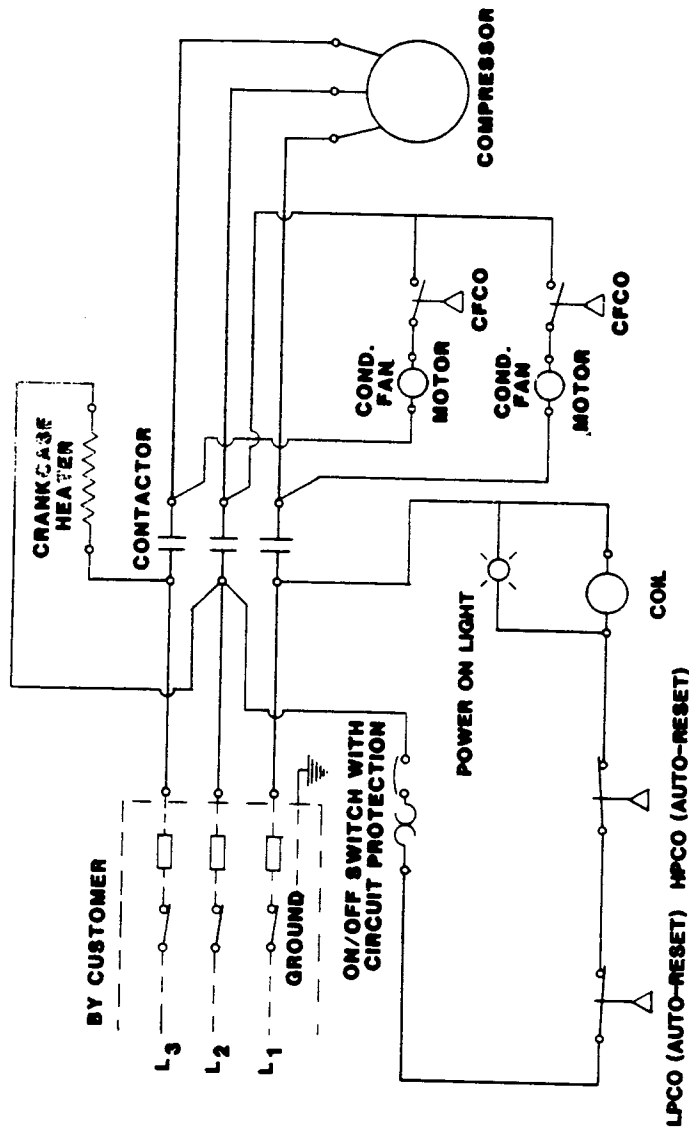

**NOTE:**

1. Compressor equipped with internal overload
2. Crankcase heater TO BE ON AT ALL TIMES
3. PDC 250-300 has one fan motor-no fan cut-out switch
4. HPCO - High pressure cut-out
5. LPCO - Low pressure cut-out
6. CFCO - Condenser fan cut-out

REV.	DATE	DESCRIPTION	BY
<small>INFORMATION ON THIS DWG. IS PROPERTY OF PURE-AIR INC. AND NO TRADE          DETAILS OR DISCLOSURES TO BE MADE WITHOUT PRIOR WRITTEN APPROVAL.</small>			
DATE: 3-20-66		SCALE:	DRAWN BY: H. MASSEY
TITLE:		PDC 250-500, 230/3/60	
		WIRING DIAGRAM	
		PURE-AIRE INC. CHARLOTTE, N. C.	
		DRAWING NUMBER <b>601339</b>	

**8322**

PDC MODEL	RATED LOAD AMPS. 460/3/60
250	4.1
300	4.1
400	5.2
500	7.1

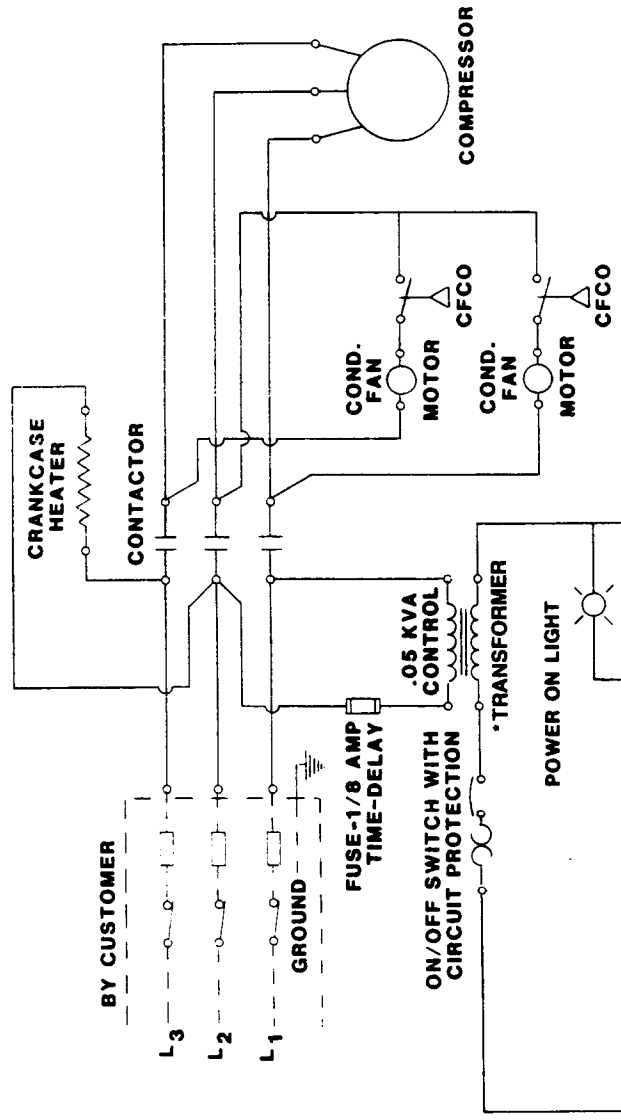

\*PDC 250-500 IS EQUIPPED WITH 230V CONTROL VOLTAGE

LPCO (AUTO-RESET) HPCO (AUTO-RESET)

**NOTE:**

1. Compressor equipped with internal overload
2. Crankcase heater TO BE ON AT ALL TIMES
3. PDC 250-300 has one fan motor-no fan cut-out switch
4. HPCO - High pressure cut-out
5. LPCO - Low pressure cut-out
6. CFCO - Condenser fan cut-out

REV	DATE	DESCRIPTION	BY
3-21-85		SCALE	DRAWN BY H. MASSEY
TITLE: PDC 250-500 460/3/60 WIRING DIAGRAM			DRAWING NUMBER 601340
PURE-AIRE INC. CHARLOTTE, N. C.			

8323

PDC MODEL	RATED LOAD AMPS. 208-230/3/60
250	7.1
300	7.1
400	10.6
500	14.4

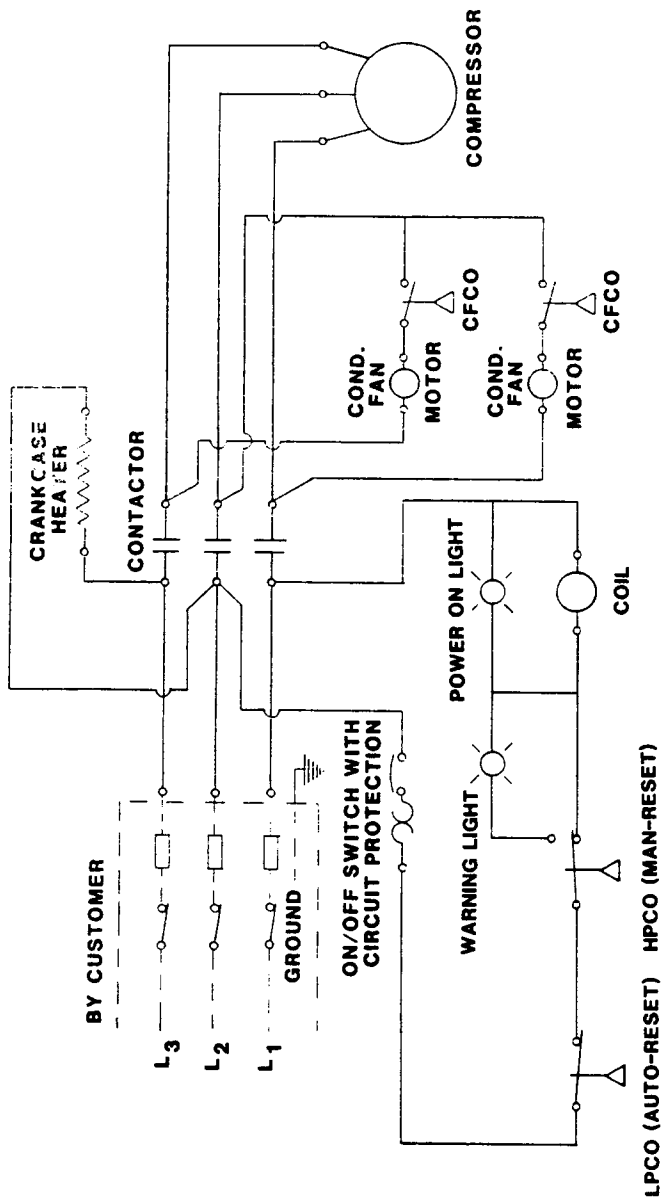

**NOTE:**

1. Compressor equipped with internal overload
2. Crankcase heater TO BE ON AT ALL TIMES
3. PDC 250-300 has one fan motor-no fan cut-out switch
4. HPCO - High pressure cut-out
5. LPCO - Low pressure cut-out
6. CFCO - Condenser fan cut-out

8324

REV	DATE	DESCRIPTION	BY
<small>INFORMATION ON THIS DRAWING IS PROPERTY OF PURE-AIRE, INC. AND NO TRADE MARKS OR DECLARATIONS TO BE MADE WITHOUT PRIOR WRITTEN APPROVAL</small>			
DATE 3-20-85		SCALE: _____	DRAWN BY H. MASSEY
TITLE PDC 250-500 230/3/60		DRAWING NUMBER 601341	
WIRING DIAGRAM (High pressure warning option)		PURE-AIRE INC. CHARLOTTE, N. C.	

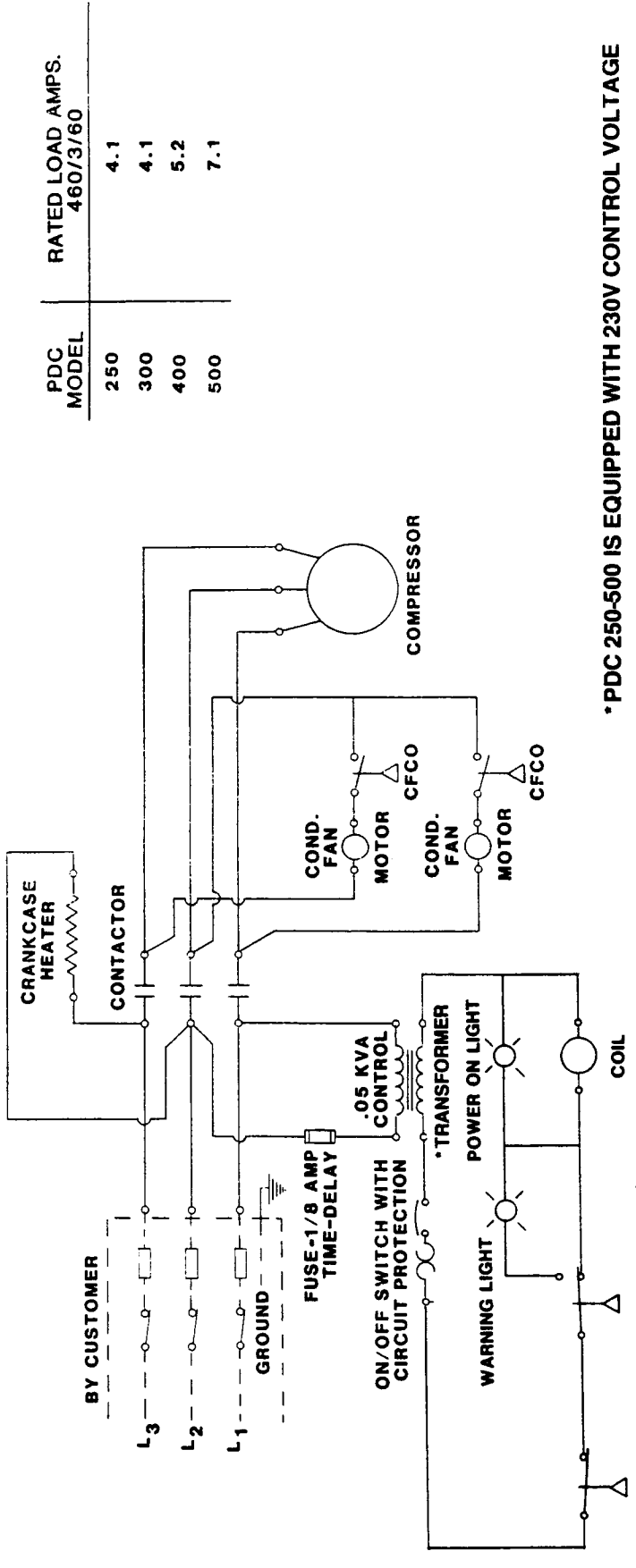

\* PDC 250-500 IS EQUIPPED WITH 230V CONTROL VOLTAGE

PDC MODEL	RATED LOAD AMPS. 460/3/60
250	4.1
300	4.1
400	5.2
500	7.1

**NOTE:**

1. Compressor equipped with internal overload
2. Crankcase heater TO BE ON AT ALL TIMES
3. PDC 250-300 has one fan motor-no fan cut-out switch
4. HPCO - High pressure cut-out
5. LPCO - Low pressure cut-out
6. CFCO - Condenser fan cut-out

LPCO (AUTO-RESET) HPCO (MAN-RESET)

REV	DATE	DESCRIPTION	BY
3-21-85		SCALE	H. MASSEY
INFORMATION ON THIS DWG IS PROPERTY OF PURE AIR INC. AND NO TRANSFERS OR DISCLOSURES TO BE MADE WITHOUT PRIOR WRITTEN APPROVAL.			
DATE		DRAWN BY	
3-21-85		H. MASSEY	
TITLE			DRAWING NUMBER
PDC 250-500 460/3/60 WIRING DIAGRAM (High pressure warning option)			601342
PURE-AIRE INC. CHARLOTTE, N. C.			

8325

DESCRIPTION	M			O			D			E			L				
	QTY	PDC 25	PDC 50	PDC 100	PDC 150	PDC 250	PDC 300	PDC 400	PDC 500	PDC 25	PDC 50	PDC 100	PDC 150	PDC 250	PDC 300	PDC 400	PDC 500
HORSEPOWER		1/4	1/3	1/2	3/4	1 1/2	1 1/2	1 1/2	2	3							
VOLTAGE		115/1/60	115/1/60	230/1/60	115/1/60	230/1/60	230/3/60	460/3/60	230/3/60	460/3/60	230/3/60	460/3/60	230/3/60	460/3/60	230/3/60	460/3/60	460/3/60
BILL OF MATERIALS		3230-115	3231-115	3232-115	3233-115	3233-230	3233-230	3233-460	3233-230	3233-460	3233-230	3233-460	3233-230	3233-460	3233-230	3233-460	3233-460
CONDENSING UNIT	1	7816	7280	7283	7283	7283	7048	7050	7056	7056	7056	7056	7056	7056	7056	7056	7517
COMPRESSOR	1	5078	5143	5147	5150	5150	5112	5115	5118	5118	5118	5118	5118	5118	5118	5118	5185
FAN MOTOR		5079	5144	5148	5151	5151	5113	5116	5113	5116	5113	5116	5113	5116	5113	5116	5126
FAN BLADE		5080	5145	5149	5155	5114	5114	5114	5114	5114	5114	5114	5114	5114	5114	5114	5127
(LOW) FAN #1 SWITCH	1	NONE	NONE	NONE	NONE	NONE	NONE	NONE	NONE	NONE	NONE	NONE	NONE	NONE	NONE	NONE	7812-1
(HIGH) FAN #2 SWITCH	1	NONE	NONE	NONE	NONE	NONE	NONE	NONE	NONE	NONE	NONE	NONE	NONE	NONE	NONE	NONE	7812-2
REFR. LOW PRESS. SWITCH	1	NONE	NONE	NONE	NONE	NONE	7576-2	7576-2	7576-2	7576-2	7576-2	7576-2	7576-2	7576-2	7576-2	7576-2	7576-1
REFR. HIGH PRESS. SWITCH	1	NONE	NONE	NONE	NONE	NONE	7576-4	7576-4	7576-4	7576-4	7576-4	7576-4	7576-4	7576-4	7576-4	7576-4	7576
SUCTION ACCUMULATOR	1	NONE	NONE	NONE	NONE	NONE	7756-5	7756-5	7756-5	7756-5	7756-5	7756-5	7756-5	7756-5	7756-5	7756-5	7756-5
CAPILLARY TUBE/FILTER DRIER	1	7275	7276	7277	7343	N/A	N/A	N/A	N/A	N/A	N/A	N/A	N/A	N/A	N/A	N/A	N/A
LIQUID LINE FILTER DRIER	1	N/A	N/A	N/A	N/A	N/A	7660	7660	7660	7660	7660	7660	7660	7660	7660	7660	7660
SIGHT GLASS/MOISTURE INDICATOR	1	N/A	N/A	N/A	N/A	N/A	7659	7659	7659	7659	7659	7659	7659	7659	7659	7659	7659
THERMO-EXPANSION VALVE	1	N/A	N/A	N/A	N/A	N/A	7822-11	7822-11	7822-11	7822-11	7822-11	7822-11	7822-11	7822-11	7822-11	7822-11	7822-13
HOT GAS BYPASS VALVE	1	7300	7300	7300	7361	7820-8	7820-8	7820-8	7820-8	7820-8	7820-8	7820-8	7820-8	7820-8	7820-8	7820-8	7820-9
F X A HEAT EXCHANGER	1	7337	7335	7333	7360	7882-424	7882-436	7882-436	7882-436	7882-436	7882-436	7882-436	7882-436	7882-436	7882-436	7882-436	7882-536
F X A HEAT EXCHGR. GASKET		NONE	NONE	NONE	NONE	5243-4	5243-4	5243-4	5243-4	5243-4	5243-4	5243-4	5243-4	5243-4	5243-4	5243-4	5243-5
A X A HEAT EXCHANGER	1	NONE	7336	7334	7334	7881-424	7881-436	7881-436	7881-436	7881-436	7881-436	7881-436	7881-436	7881-436	7881-436	7881-436	7881-630
A X A HEAT EXCHGR. GASKET		NONE	NONE	NONE	NONE	5244-4	5244-4	5244-4	5244-4	5244-4	5244-4	5244-4	5244-4	5244-4	5244-4	5244-4	5244-6
REFR. SUCTION PRESS. GAUGE	1	7873	7873	7873	7873	7873	7873	7873	7873	7873	7873	7873	7873	7873	7873	7873	7873
REFR. HEAD PRESS. GAUGE	1	NONE	NONE	NONE	NONE	7874	7874	7874	7874	7874	7874	7874	7874	7874	7874	7874	7874
DRAIN TRAP/SEPARATOR	1	7920	7920	7907	7907	N/A	N/A	N/A	N/A	N/A	N/A	N/A	N/A	N/A	N/A	N/A	N/A
DRAIN TRAP	1	N/A	N/A	N/A	N/A	7777	7777	7777	7777	7777	7777	7777	7777	7777	7777	7777	7777
ON-OFF SWITCH/CIRCUIT BREAKER	1	7868-1	7868-3	7868-2	7868-2	7868-4	7868-4	7868-4	7868-4	7868-4	7868-4	7868-4	7868-4	7868-4	7868-4	7868-4	7868-4
POWER INDICATING LIGHT	1	7787-1	7787-1	7787-1	7787-1	7787-1	7787-1	7787-1	7787-1	7787-1	7787-1	7787-1	7787-1	7787-1	7787-1	7787-1	7787-1
FUSE	1	NONE	NONE	NONE	NONE	7796	7796	7796	7796	7796	7796	7796	7796	7796	7796	7796	7796
FUSE BLOCK	1	NONE	NONE	NONE	NONE	7888	7888	7888	7888	7888	7888	7888	7888	7888	7888	7888	7888
CONTROL TRANSFORMER	1	NONE	NONE	NONE	NONE	7889	7889	7889	7889	7889	7889	7889	7889	7889	7889	7889	7889
CRANKCASE HEATER	1	NONE	NONE	NONE	NONE	7706-1	7706	7706	7706-1	7706	7706-1	7706	7706-1	7706	7706-1	7706	7706-1
HAND CONTROL VALVE	1	NONE	NONE	NONE	NONE	7825-1	7825-1	7825-1	7825-1	7825-1	7825-1	7825-1	7825-1	7825-1	7825-1	7825-1	7825-2

NOTES:

- THIS PARTS LIST IS FOR UNITS WITH 'N' AS DESIGNATED IN SERIAL NUMBER. (PDC 250-500).
- EXAMPLE: PDC SERIAL NO. X-XXXX-XXXX-XXXX (N) X
- THIS PARTS LIST IS EFFECTIVE 4-1-85.

REV	DATE	DESCRIPTION	BY
<small>INFORMATION ON THIS DRAWING IS THE PROPERTY OF PURE-AIRE, INC. AND NO PARTS, MATERIALS OR DIMENSIONS SHOULD BE MADE WITHOUT WRITTEN APPROVAL.</small>			
<small>DATE: 3-28-85</small>		<small>DRAWN BY: BTR</small>	
<b>PARTS LIST</b> -PDC- MODELS-			
PURE-AIRE, INC. CHARLOTTE, N. C.			101375

8326

DESCRIPTION	M			O			D			E			L			
	PDC 25	PDC 50	PDC 100	PDC 150	PDC 250	PDC 300	PDC 400	PDC 500	PDC 25	PDC 50	PDC 100	PDC 150	PDC 250	PDC 300	PDC 400	PDC 500
HORSEPOWER	1/4	1/3	1/2	3/4	1 1/2	1 1/2	2	3	1/4	1/3	1/2	3/4	1 1/2	1 1/2	2	3
VOLTAGE	115/1/60	115/1/60	230/1/60	115/1/60	230/3/60	460/3/60	230/3/60	460/3/60	115/1/60	230/1/60	230/3/60	230/1/60	230/3/60	230/3/60	460/3/60	460/3/60
BILL OF MATERIALS	3230-115	3231-115	3232-115	3233-115	3234-230	3235-230	3236-230	3237-460	3238-115	3239-230	3240-230	3241-230	3242-460	3243-230	3244-460	3245-460
CONDENSING UNIT	7816	7280	7282	7346-1	7048	7050	7056	7058	7346-1	7048	7050	7056	7058	7056	7058	7516
COMPRESSOR	5078	5143	5147	5225	5112	5115	5118	5185	5225	5143	5147	5112	5115	5118	5119	5185
FAN MOTOR	5079	5144	5148	5227	5113	5116	5116	5126	5227	5154	5113	5116	5116	5113	5116	5126
FAN BLADE	5080	5145	5149	5155	5114	5114	5114	5127	5155	5145	5149	5114	5114	5114	5114	5127
(LOW) FAN #1 SWITCH	NONE	NONE	NONE	NONE	NONE	NONE	7812-3	7812-1	NONE	NONE	NONE	NONE	NONE	NONE	7812-3	7812-1
(HIGH) FAN #2 SWITCH	NONE	NONE	NONE	NONE	NONE	NONE	7812-4	7812-2	NONE	NONE	NONE	NONE	NONE	NONE	7812-4	7812-2
REFR. LOW PRESS. SWITCH	NONE	NONE	NONE	NONE	7576-2	7576-2	7576-2	7576-1	NONE	NONE	7576-2	7576-2	7576-2	7576-2	7576-2	7576-1
REFR. HIGH PRESS. SWITCH	NONE	NONE	NONE	NONE	7576-4	7576-4	7576-4	7576	NONE	NONE	7576-4	7576-4	7576-4	7576-4	7576-4	7576
SUCTION ACCUMULATOR	NONE	NONE	NONE	NONE	7756-5	7756-5	7756-5	7756-5	NONE	NONE	7756-5	7756-5	7756-5	7756-5	7756-5	7756-5
CAPILLARY TUBE/FILTER DRIER	7275	7276	7277	7343	N/A	N/A	N/A	N/A	7275	7276	7277	7343	N/A	N/A	N/A	N/A
LIQUID LINE FILTER DRIER	N/A	N/A	N/A	N/A	7660	7660	7660	7660	N/A	N/A	7660	7660	7660	7660	7660	7660
SIGHT GLASS/MOISTURE INDICATOR	N/A	N/A	N/A	N/A	7659	7659	7659	7659	N/A	N/A	7659	7659	7659	7659	7659	7659
THERMO-EXPANSION VALVE	N/A	N/A	N/A	N/A	7822-11	7822-11	7822-12	7822-13	N/A	N/A	7822-11	7822-11	7822-12	7822-12	7822-12	7822-13
HOT GAS BYPASS VALVE	7300	7300	7300	7361	7820-8	7820-8	7820-8	7820-9	7300	7300	7300	7361	7820-8	7820-8	7820-8	7820-9
F X A HEAT EXCHANGER	7337	7335	7333	7360	7879-436	7879-436	7879-530	7879-536	7337	7335	7333	7360	7879-436	7879-530	7879-530	7879-536
F X A HEAT EXCHGR. GASKET	NONE	NONE	NONE	NONE	5238-4	5238-4	5238-5	5238-5	NONE	NONE	5238-4	5238-4	5238-4	5238-5	5238-5	5238-5
A X A HEAT EXCHANGER	NONE	7336	7334	7334	7778-430	7778-436	7778-530	7778-630	NONE	7336	7334	7334	7778-430	7778-436	7778-530	7778-630
A X A HEAT EXCHGR. GASKET	NONE	NONE	NONE	NONE	5238-4	5238-4	5218-5	5218-6	NONE	NONE	5238-4	5238-4	5238-4	5218-5	5218-5	5218-6
REFR. SUCTION PRESS. GAUGE	7873	7873	7873	7873	7873	7873	7873	7873	7873	7873	7873	7873	7873	7873	7873	7873
REFR. HEAD PRESS. GAUGE	NONE	NONE	NONE	NONE	7874	7874	7874	7874	NONE	NONE	7874	7874	7874	7874	7874	7874
DRAIN TRAP/SEPARATOR	7920	7920	7907	7907	N/A	N/A	N/A	N/A	7920	7920	7907	7907	N/A	N/A	N/A	N/A
DRAIN TRAP	N/A	N/A	N/A	N/A	7777	7777	7777	7777	N/A	N/A	7777	7777	7777	7777	7777	7777
ON-OFF SWITCH/CIRCUIT BREAKER	7868-1	7868-3	7868-2	7868-2	7868-4	7868-4	7868-4	7868-4	7868-1	7868-3	7868-2	7868-2	7868-4	7868-4	7868-4	7868-4
POWER INDICATING LIGHT	7787-1	7787-1	7787-1	7787-1	7787-1	7787-1	7787-1	7787-1	7787-1	7787-1	7787-1	7787-1	7787-1	7787-1	7787-1	7787-1
FUSE	NONE	NONE	NONE	NONE	7796	7796	7796	7796	NONE	NONE	7796	7796	7796	7796	7796	7796
FUSE BLOCK	NONE	NONE	NONE	NONE	7888	7888	7888	7888	NONE	NONE	7888	7888	7888	7888	7888	7888
CONTROL TRANSFORMER	NONE	NONE	NONE	NONE	7889	7889	7889	7889	NONE	NONE	7889	7889	7889	7889	7889	7889
CRANKCASE HEATER	NONE	NONE	NONE	NONE	7706-1	7706	7706	7706-1	NONE	NONE	7706-1	7706	7706	7706-1	7706	7706-1
HAND CONTROL VALVE	NONE	NONE	NONE	NONE	7825-1	7825-1	7825-1	7825-2	NONE	NONE	7825-1	7825-1	7825-1	7825-1	7825-1	7825-2

NOTES:  
1. THIS PARTS LIST IS FOR UNITS WITH "S" AS DESIGNATED IN SERIAL NUMBER. (PDC 250-500).  
2. EXAMPLE: PDC SERIAL NO. X-XXXX-XXXX-XXXX (S) X  
3. THIS PARTS LIST IS EFFECTIVE 4-1-85.

REV.	DATE	DESCRIPTION	BY
<small>INFORMATION ON THIS SHEET IS PROPERTY OF PUREAIR INC. AND NO PARTS OR SERVICES SHOULD BE ORDERED OR USED WITHOUT THE WRITTEN AUTHORIZATION OF PUREAIR INC.</small>			
<small>CALL 1-800-3-28-85 FOR PARTS LIST INFORMATION</small>			
<small>ISSUED BY: BTR</small>			
<b>PARTS LIST</b> <b>"PDC" MODELS</b>			<small>DRAWING NUMBER</small> <b>601376</b>
<small>PUREAIR INC.</small> <small>CHARLOTTE, N.C.</small>			<b>8288</b>

MODEL	11" 25"	14" 50"	18" 100"	24" 150"	30" 250"	36" 300"	42" 400"	48" 500"
FLOW CAPACITY 1	23	50	110	170	240	300	400	500
ECONOMY FLOW	S.C.F.M. @ 35°F. PRESSURE DEWPOINT	85	187	289	425	510	680	850
	M <sup>3</sup> /HR. @ 2°C. PRESSURE DEWPOINT	60	130	200	300	360	480	600
POWER INPUT (KW)	S.C.F.M. @ 50°F. PRESSURE DEWPOINT	102	221	340	510	612	816	1020
	M <sup>3</sup> /HR @ 10°C. PRESSURE DEWPOINT	0.45	0.54	0.86	1.19	2.05	2.83	4.35
AIR INLET/OUTLET CONNECTION (FPT)	1/2	3/4	1	1 1/4	1 1/2	1 1/2	2	2
DRAIN CONNECTION (FPT)	1/4	1/4	1/4	1/4	3/4	3/4	3/4	3/4
REFRIGERANT COMPRESSOR HORSEPOWER RATING (HP)	1/4	1/2	1/2	3/4	1 1/2	1 1/2	2	3
MAXIMUM HEAT OF REJECTION <sup>2</sup> (BTU/HR.)	1295	2793	6145	9497	13966	16759	22145	27931
COOLING AIR FLOW (CFM)	280	375	350	800	1125	1125	2000	2100
REFRIGERANT	R-12	R-12	R-12	R-12	R-12	R-12	R-12	R-22
VOLTAGE *	A	A	A, B	A, B	C, D	C, D	C, D	C, D
HEIGHT	IN.	20	22	26	39	39	39	39
	MM.	445	508	660	991	991	991	991
WIDTH	IN.	14 1/2	17	22	25 1/2	28	28	28
	MM.	375	432	559	648	711	711	711
LENGTH	IN.	17	18	22	26	53	53	53
	MM.	432	457	559	660	1346	1346	1346
WEIGHT	LIBS.	65	162	185	235	520	520	520
	KGS.	29	73	84	107	236	236	236

\*VOLTAGE CODE:  
A- 115/1/60  
B- 230/1/60  
C- 230/3/60  
D- 460/3/60

NOTE:  
1. FLOW CAPACITY RATING IS BASED AT 100°F AIR INLET TEMPERATURE, 100 PSIG. AIR INLET PRESSURE AND 100°F. AMBIENT TEMPERATURE.  
2. MAXIMUM HEAT OF REJECTION IS BASED AT 120°F. CONDENSING TEMPERATURE AND 3. F. EVAPORATING TEMPERATURE.

REV.	DATE:	DESCRIPTION:	BY:
<small>INFORMATION ON THIS DWG. IS PROPERTY OF PURE-AIRE INC. AND NO TRANSFERS, REPRODUCTIONS, COPIES, OR DISCLOSURES TO BE MADE WITHOUT PRIOR WRITTEN APPROVAL.</small>			
DATE: 3-21-85	SCALE:	DRAWN BY: BTR	
TITLE:			

**SPECIFICATION SHEET**

PURE-AIRE INC.  
CHARLOTTE, N. C.

DRAWING NUMBER  
**601338**

**8321**







Part No.



250041-222