



**INDUSTRIAL AIR
COMPRESSOR
LS20TS
300-450HP/ 224-336KW
WATER-COOLED
SUPERVISOR II**

**OPERATOR'S
MANUAL AND
PARTS LIST**

**KEEP FOR
FUTURE
REFERENCE**

Part Number 02250144-309
©Sullair Corporation

AIR CARE SEMINAR TRAINING

Sullair Air Care Seminars are 3-day courses that provide hands-on instruction in the proper operation, maintenance and service of Sullair equipment. Individual seminars on Industrial compressors and compressor electrical systems are presented at regular intervals throughout the year at a dedicated training facility at Sullair's corporate headquarters in Michigan City, Indiana.

Instruction includes discussion of the function and installation of Sullair service parts, troubleshooting of the most common problems, and actual equipment operation. The seminars are recommended for maintenance and service personnel.

For detailed course outlines, schedule and cost information contact:

Sullair Corporate Training Department
1-888-SULLAIR or 219-879-5451 (ext. 5363)
www.sullair.com/training.shtm

- Or Write -

Sullair Corporation
3700 E. Michigan Blvd.
Michigan City, IN 46360
Attn: Service Training Department

TABLE OF CONTENTS



**OPERATOR IS REQUIRED TO READ
ENTIRE INSTRUCTION MANUAL**

Section 1 SAFETY

PAGE

1	1.1 GENERAL
1	1.2 PERSONAL PROTECTIVE EQUIPMENT
1	1.3 PRESSURE RELEASE
2	1.4 FIRE AND EXPLOSION
2	1.5 MOVING PARTS
2	1.6 HOT SURFACES, SHARP EDGES AND SHARP CORNERS
2	1.7 TOXIC AND IRRITATING SUBSTANCES
3	1.8 ELECTRICAL SHOCK
3	1.9 LIFTING
4	1.10 ENTRAPMENT

Section 2 DESCRIPTION

5	2.1 INTRODUCTION
5	2.2 DESCRIPTION OF COMPONENTS
5	2.3 SULLAIR COMPRESSOR UNIT, FUNCTIONAL DESCRIPTION
5	2.4 COMPRESSOR COOLING AND LUBRICATION SYSTEM, FUNCTIONAL DESCRIPTION
5	2.5 COMPRESSOR DISCHARGE SYSTEM, FUNCTIONAL DESCRIPTION
8	2.6 CONTROL CAPACITY SYSTEM, FUNCTIONAL DESCRIPTION
19	2.7 AIR INLET SYSTEM, FUNCTIONAL DESCRIPTION
19	2.8 SUPERVISOR II PANEL BASIC INTRODUCTION
19	2.9 KEYPAD
20	2.10 STATUS DISPLAYS
22	2.11 LAMP INDICATORS

Section 3 SPECIFICATIONS

23	3.1 SPECIFICATIONS- LS20TS
23	3.2 LUBRICATION GUIDE- STANDARD COMPRESSORS
24	3.3 APPLICATION GUIDE

TABLE OF CONTENTS

Section 4 INSTALLATION

27	4.1 MOUNTING OF COMPRESSOR
27	4.2 VENTILATION AND COOLING
27	4.3 SERVICE AIR PIPING
27	4.4 COUPLING ALIGNMENT CHECK
27	4.5 FLUID LEVEL CHECK
28	4.6 ELECTRICAL PREPARATION
28	4.7 MOTOR ROTATION DIRECTION CHECK

Section 5 OPERATION

29	5.1 GENERAL
29	5.2 PURPOSE OF CONTROLS
30	5.3 PARAMETERS SETUP
31	5.4 OPERATING THE COMPRESSOR
32	5.5 SUPERVISOR II OUTPUT RELAYS
33	5.6 INITIAL START-UP PROCEDURE
33	5.7 SUBSEQUENT START-UP PROCEDURE
33	5.8 SHUTDOWN PROCEDURE

Section 6 MAINTENANCE

35	6.1 MAINTENANCE INTRODUCTION
35	6.2 DAILY OPERATION
35	6.3 MAINTENANCE AFTER INITIAL 50 HOURS OF OPERATION
35	6.4 MAINTENANCE AS REQUIRED BY LUBRICATION GUIDE (SECTION 3)
35	6.5 FLUID CHANGE
35	6.6 SEPARATOR MAINTENANCE
35	6.7 PARTS REPLACEMENT AND ADJUSTMENT PROCEDURES
35	FLUID FILTER MAINTENANCE
36	AIR FILTER MAINTENANCE
37	SEPARATOR MAINTENANCE
38	OIL RETURN/SIGHT GLASS MAINTENANCE
38	DIFFERENTIAL PRESSURE REGULATOR ADJUSTMENT
39	DRIVE COUPLING INSTALLATION AND ALIGNMENT

Section 7 TROUBLESHOOTING

41	7.1 TROUBLESHOOTING
41	7.2 TROUBLESHOOTING GUIDE

TABLE OF CONTENTS

Section 8 ILLUSTRATIONS AND PARTS LIST

45	8.1 PROCEDURE FOR ORDERING PARTS
45	8.2 RECOMMENDED SPARE PARTS LIST
48	8.3 MOTOR, FRAME, COMPRESSOR AND PARTS- 300-450HP/ 224-336KW
50	8.4 AIR INLET SYSTEM
54	8.5 AIR INLET SYSTEM WITH OIL INJECTION INLET VALVE
58	8.6 FLUID COOLING SYSTEM- 300-450HP/ 224-336KW WATER-COOLED
60	8.7 AIR PIPING SYSTEM- 300-450HP/ 224-336KW WATER-COOLED
62	8.8 FLUID PIPING SYSTEM- 300-450HP/ 224-336KW WATER-COOLED
66	8.9 DISCHARGE SYSTEM
72	8.10 CONTROL/START SYSTEM
76	8.11 CONTROL PANEL
78	8.12 ENCLOSURE AND ENCLOSURE DECALS
80	8.13 DECAL GROUP
86	8.14 DECAL LOCATIONS- OPEN WATER-COOLED
88	8.15 DECAL LOCATIONS- CONTROL BOX
90	8.16 WIRING DIAGRAM- LS20TS WATER-COOLED

Section 1 SAFETY

1.1 GENERAL

Sullair Corporation and its subsidiaries design and manufacture all of their products so they can be operated safely. However, the responsibility for safe operation rests with those who use and maintain these products. The following safety precautions are offered as a guide which, if conscientiously followed, will minimize the possibility of accidents throughout the useful life of this equipment.

The compressor should be operated only by those who have been trained and delegated to do so, and who have read and understood this Operator's Manual. Failure to follow the instructions, procedures and safety precautions in this manual may result in accidents and injuries.

NEVER start the compressor unless it is safe to do so. **DO NOT** attempt to operate the compressor with a known unsafe condition. Tag the compressor and render it inoperative by disconnecting and locking out all power at source or otherwise disabling its prime mover so others who may not know of the unsafe condition cannot attempt to operate it until the condition is corrected.

Install, use and operate the compressor only in full compliance with all pertinent OSHA regulations and/or any applicable Federal, State, and Local codes, standards and regulations.

DO NOT modify the compressor and/or controls in any way except with written factory approval.

While not specifically applicable to all types of compressors with all types of prime movers, most of the precautionary statements contained herein are applicable to most compressors and the concepts behind these statements are generally applicable to all compressors.

1.2 PERSONAL PROTECTIVE EQUIPMENT

Prior to installing or operating the compressor, owners, employers and users should become familiar with, and comply with, all applicable OSHA regulations and/or any applicable Federal, State and Local codes, standards, and regulations relative to personal protective equipment, such as eye and face protective equipment, respiratory protective equipment, equipment intended to protect the extremities, protective clothing, protective shields and barriers and electrical protective equipment, as well as noise exposure administrative and/or engineering controls and/or personal hearing protective equipment.

1.3 PRESSURE RELEASE

A. Install an appropriate flow-limiting valve between

the service air outlet and the shut-off (throttle) valve, either at the compressor or at any other point along the air line, when an air hose exceeding 13mm inside diameter is to be connected to the shut-off (throttle) valve, to reduce pressure in case of hose failure, per OSHA Standard 29 CFR 1926.302(b)(7) and/or any applicable Federal, State and Local codes, standards and regulations.

B. When the hose is to be used to supply a manifold, install an additional appropriate flow-limiting valve between the manifold and each air hose exceeding 13mm inside diameter that is to be connected to the manifold to reduce pressure in case of hose failure.

C. Provide an appropriate flow-limiting valve at the beginning of each additional 23m of hose in runs of air hose exceeding 13mm inside diameter to reduce pressure in case of hose failure.

D. Flow-limiting valves are listed by pipe size and flow-rated. Select appropriate valves accordingly, in accordance with their manufacturer's recommendations.

E. DO NOT use air tools that are rated below the maximum rating of the compressor. Select air tools, air hoses, pipes, valves, filters and other fittings accordingly. **DO NOT** exceed manufacturer's rated safe operating pressures for these items.

F. Secure all hose connections by wire, chain or other suitable retaining device to prevent tools or hose ends from being accidentally disconnected and expelled.

G. Open fluid filler cap only when compressor is not running and is not pressurized. Shut down the compressor and bleed the sump (receiver) to zero internal pressure before removing the cap.

H. Vent all internal pressure prior to opening any line, fitting, hose, valve, drain plug, connection or other component, such as filters and line oilers, and before attempting to refill optional air line anti-icer systems with antifreeze compound.

I. Keep personnel out of line with and away from the discharge opening of hoses or tools or other points of compressed air discharge.

J. Use air at pressures less than 2.1 bar for cleaning purposes, and then only with effective chip guarding and personal protective equipment per OSHA Standard 29 CFR 1910.242 (b) and/or any applicable Federal, State, and Local codes, standards and regulations.

K. DO NOT engage in horseplay with air hoses as

Section 1

SAFETY

death or serious injury may result.

1.4 FIRE AND EXPLOSION

A. Clean up spills of lubricant or other combustible substances immediately, if such spills occur.

B. Shut off the compressor and allow it to cool. Then keep sparks, flames and other sources of ignition away and **DO NOT** permit smoking in the vicinity when checking or adding lubricant or when refilling air line anti-icer systems with antifreeze compound.

C. DO NOT permit fluids, including air line anti-icer system antifreeze compound or fluid film, to accumulate on, under or around acoustical material, or on any external surfaces of the air compressor. Wipe down using an aqueous industrial cleaner or steam clean as required. If necessary, remove acoustical material, clean all surfaces and then replace acoustical material. Any acoustical material with a protective covering that has been torn or punctured should be replaced immediately to prevent accumulation of liquids or fluid film within the material. **DO NOT** use flammable solvents for cleaning purposes.

D. Disconnect and lock out all power at source prior to attempting any repairs or cleaning of the compressor or of the inside of the enclosure, if any.

E. Keep electrical wiring, including all terminals and pressure connectors in good condition. Replace any wiring that has cracked, cut, abraded or otherwise degraded insulation, or terminals that are worn, discolored or corroded. Keep all terminals and pressure connectors clean and tight.

F. Keep grounded and/or conductive objects such as tools away from exposed live electrical parts such as terminals to avoid arcing which might serve as a source of ignition.

G. Remove any acoustical material or other material that may be damaged by heat or that may support combustion and is in close proximity, prior to attempting weld repairs.

H. Keep suitable fully charged Class BC or ABC fire extinguisher or extinguishers nearby when servicing and operating the compressor.

I. Keep oily rags, trash, leaves, litter or other combustibles out of and away from the compressor.

J. DO NOT operate the compressor without proper flow of cooling air or water or with inadequate flow of lubricant or with degraded lubricant.

K. DO NOT attempt to operate the compressor in any classification of hazardous

environment unless the compressor has been specially designed and manufactured for that duty.

1.5 MOVING PARTS

A. Keep hands, arms and other parts of the body and also clothing away from couplings, fans and other moving parts.

B. DO NOT attempt to operate the compressor with the fan, coupling or other guards removed.

C. Wear snug-fitting clothing and confine long hair when working around this compressor, especially when exposed to hot or moving parts.

D. Keep access doors, if any, closed except when making repairs or adjustments.

E. Make sure all personnel are out of and/or clear of the compressor prior to attempting to start or operate it.

F. Disconnect and lock out all power at source and verify at the compressor that all circuits are de-energized to minimize the possibility of accidental start-up, or operation, prior to attempting repairs or adjustments. This is especially important when compressors are remotely controlled.

G. Keep hands, feet, floors, controls and walking surfaces clean and free of fluid, water or other liquids to minimize the possibility of slips and falls.

1.6 HOT SURFACES, SHARP EDGES AND SHARP CORNERS

A. Avoid bodily contact with hot fluid, hot coolant, hot surfaces and sharp edges and corners.

B. Keep all parts of the body away from all points of air discharge.

C. Wear personal protective equipment including gloves and head covering when working in, on or around the compressor.

D. Keep a first aid kit handy. Seek medical assistance promptly in case of injury. **DO NOT** ignore small cuts and burns as they may lead to infection.

1.7 TOXIC AND IRRITATING SUBSTANCES

A. DO NOT use air from this compressor for respiration (breathing) except in full compliance with OSHA Standards 29 CFR 1910 and/or any applicable Federal, State, and Local codes, standards and regulations.



Death or serious injury can result from inhaling compressed air without using proper safety equipment. See OSHA standards and/or any applicable Federal, State, and Local codes, standards and regulations on safety equipment.

B. DO NOT use air line anti-icer systems in air lines

Section 1 SAFETY

supplying respirators or other breathing air utilization equipment and **DO NOT** discharge air from these systems into unventilated or other confined areas.

C. Operate the compressor only in open or adequately ventilated areas.

D. Locate the compressor or provide a remote inlet so that it is not likely to ingest exhaust fumes or other toxic, noxious or corrosive fumes or substances.

E. Coolants and lubricants used in this compressor are typical of the industry. Care should be taken to avoid accidental ingestion and/or skin contact. In the event of ingestion, seek medical treatment promptly. Wash with soap and water in the event of skin contact. Consult Material Safety Data Sheet for information pertaining to fluid of fill.

F. Wear goggles or a full face shield when adding antifreeze compound to air line anti-icer systems.

G. If air line anti-icer system antifreeze compound enters the eyes or if fumes irritate the eyes, they should be washed with large quantities of clean water for fifteen minutes. A physician, preferably an eye specialist, should be contacted immediately.

H. DO NOT store air line anti-icer system antifreeze compound in confined areas.

I. The antifreeze compound used in air line antifreeze systems contains methanol and is toxic, harmful or fatal if swallowed. Avoid contact with the skin or eyes and avoid breathing the fumes. If swallowed, induce vomiting by administering a tablespoon of salt, in each glass of clean, warm water until vomit is clear, then administer two teaspoons of baking soda in a glass of clean water. Have patient lay down and cover eyes to exclude light. Call a physician immediately.

1.8 ELECTRICAL SHOCK

A. This compressor should be installed and maintained in full compliance with all applicable Federal, State and Local codes, standards and regulations, including those of the National Electrical Code, and also including those relative to equipment grounding conductors, and only by personnel that are trained, qualified and delegated to do so.

B. Keep all parts of the body and any hand-held tools or other conductive objects away from exposed live parts of electrical system. Maintain dry footing, stand on insulating surfaces and **DO NOT** contact any other portion of the compressor when making adjustments or repairs to exposed live parts of the electrical system. Make all such adjustments

or repairs with one hand only, so as to minimize the possibility of creating a current path through the heart.

C. Attempt repairs in clean, dry and well lighted and ventilated areas only.

D. DO NOT leave the compressor unattended with open electrical enclosures. If necessary to do so, then disconnect, lock out and tag all power at source so others will not inadvertently restore power.

E. Disconnect, lock out, and tag all power at source prior to attempting repairs or adjustments to rotating machinery and prior to handling any ungrounded conductors.

1.9 LIFTING

A. If the compressor is provided with a lifting bail, then lift by the bail provided. If no bail is provided, then lift by sling. Compressors to be air-lifted by helicopter must not be supported by the lifting bail but by slings instead. In any event, lift and/or handle only in full compliance with OSHA standards 29 CFR 1910 subpart N and/or any applicable Federal, State, and Local codes, standards and regulations.

B. Inspect points of attachment for cracked welds and for cracked, bent, corroded or otherwise degraded members and for loose bolts or nuts prior to lifting.

C. Make sure entire lifting, rigging and supporting structure has been inspected, is in good condition and has a rated capacity of at least the weight of the compressor. If you are unsure of the weight, then weigh compressor before lifting.

D. Make sure lifting hook has a functional safety latch or equivalent, and is fully engaged and latched on the bail or slings.

E. Use guide ropes or equivalent to prevent twisting or swinging of the compressor once it has been lifted clear of the ground.

F. DO NOT attempt to lift in high winds.

G. Keep all personnel out from under and away from the compressor whenever it is suspended.

H. Lift compressor no higher than necessary.

I. Keep lift operator in constant attendance whenever compressor is suspended.

J. Set compressor down only on a level surface capable of safely supporting at least its weight and its loading unit.

K. When moving the compressor by forklift truck, utilize fork pockets if provided. Otherwise, utilize

Section 1

SAFETY

pallet if provided. If neither fork pockets or pallet are provided, then make sure compressor is secure and well balanced on forks before attempting to raise or transport it any significant distance.

L. Make sure forklift truck forks are fully engaged and tipped back prior to lifting or transporting the compressor.

M. Forklift no higher than necessary to clear obstacles at floor level and transport and corner at minimum practical speeds.

N. Make sure pallet-mounted compressors are firmly bolted or otherwise secured to the pallet prior to attempting to forklift or transport them. **NEVER** attempt to forklift a compressor that is not secured to its pallet, as uneven floors or sudden stops may

cause the compressor to tumble off, possibly causing serious injury or property damage in the process.

1.10 ENTRAPMENT

A. If the compressor enclosure, if any, is large enough to hold a man and if it is necessary to enter it to perform service adjustments, inform other personnel before doing so, or else secure and tag the access door in the open position to avoid the possibility of others closing and possibly latching the door with personnel inside.

B. Make sure all personnel are out of compressor before closing and latching enclosure doors.

Section 2 DESCRIPTION

2.1 INTRODUCTION

Your new Sullair lubricated rotary screw air compressor will provide you with a unique experience in improved reliability and greatly reduced maintenance.

Compared to other types of compressors, the Sullair rotary screw is unique in mechanical reliability, with minimal wear and no inspection required of the working parts within the compressor unit.

Read Section 6 (Maintenance) to see how to keep your air compressor in top operating condition. Should any questions arise which cannot be answered in the following text, call your nearest Sullair representative or the Sullair Corporation Service Department.

2.2 DESCRIPTION OF COMPONENTS

Refer to Figure 2-1. The components and assemblies of the air compressor are clearly shown. The complete package includes **compressor, electric motor, compressor inlet system, compressor discharge system, compressor cooling and lubrication system, capacity control system** and **“Supervisor II Control System”** all mounted on a structural steel frame.

On air-cooled models, the cooling package is mounted within the package. The separate motor-driven fan cooling package forces air through the coolers, which removes the heat of compression from the cooling fluid.

2.3 SULLAIR COMPRESSOR UNIT, FUNCTIONAL DESCRIPTION

Sullair air compressors feature the Sullair compressor unit, a two-stage, positive displacement, lubricated-type compressor. This unit provides continuous pulse-free air compression to meet your needs. With a Sullair compressor, there is no maintenance or inspection of the internal parts of the compressor unit permitted in accordance with the terms of the warranty.

Fluid is injected into the compressor unit at each stage, and mixes directly with the air as the rotors turn, compressing the air. The fluid flow has three main functions:

- As coolant, it controls the rise of air temperature normally associated with the heat of compression.
- Seals between the rotors and the stator and also between the rotors themselves.
- Acts as a lubricating film between the rotors allowing one rotor to directly drive the other, which is an idler.

After the air/fluid mixture is discharged from the compressor unit, the fluid is separated from the air. At this time, the air flows to the service line and the fluid is cooled in preparation for reinjection.

2.4 COMPRESSOR COOLING AND LUBRICATION SYSTEM, FUNCTIONAL DESCRIPTION

Refer to Figures 2-2, and 2-3. The cooling and lubrication system consists of a fluid cooler, aftercooler, full flow fluid filters, fluid stop valve, thermal valve and interconnection piping. For water-cooled models, a shell and tube fluid cooler and aftercooler are mounted on the compressor package. For air-cooled models, they are radiator-type coolers, and are mounted on the compressor package.

The pressure in the receiver/sump causes fluid flow by forcing the fluid from the high pressure area of the sump to an area of lower pressure in the compressor unit.

Fluid flows from the bottom of the receiver/sump to the thermal valve. The thermal valve bypass is fully open when the discharge temperature is below 220°F (104.4°C). The fluid passes through the thermal valve, the main fluid filter and directly to the compressor unit, thus feeding the bearings, seals and rotor area.

As the discharge temperature rises above 220°F (104.4°C), due to the heat of compression, the thermal valve bypass begins to close and a portion of the fluid then flows through the cooler. From the cooler, the fluid flows to the main filter and on to the compressor unit. The fluid filter has a replacement element and an integral pressure bypass valve.

The fluid stop valve prevents fluid from filling the compressor unit when the compressor is shut down. When the compressor is operating, the fluid stop valve is held open by air pressure from the compressor unit allowing a free flow of fluid from the receiver/sump back to the compressor unit. On shutdown, the compressor unit pressure is reduced, causing the fluid stop valve to close and isolate the compressor unit from the cooling system.

2.5 COMPRESSOR DISCHARGE SYSTEM, FUNCTIONAL DESCRIPTION

Refer to Figures 2-2 and 2-3. The compressor unit discharges the compressed air/fluid moisture through a discharge check valve into the combination receiver/sump. The discharge check valve prevents air in the receiver from returning to the compression chamber after the compressor has been shut down. The receiver has three functions:

- It acts as a primary fluid separator.

Section 2 DESCRIPTION

Figure 2-1 Sullair Series LS20TS Rotary Screw Compressor- Water-cooled (Typical)

FRONT VIEW

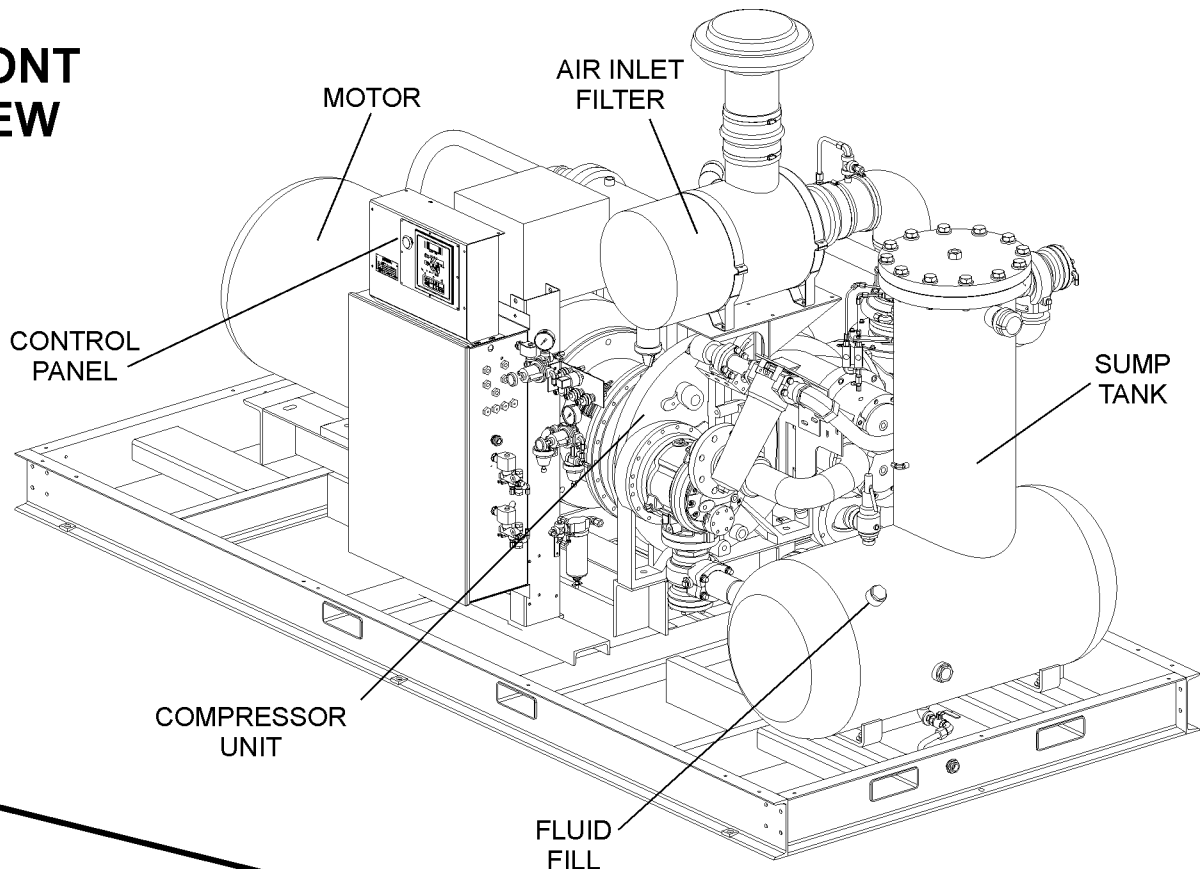

REAR VIEW

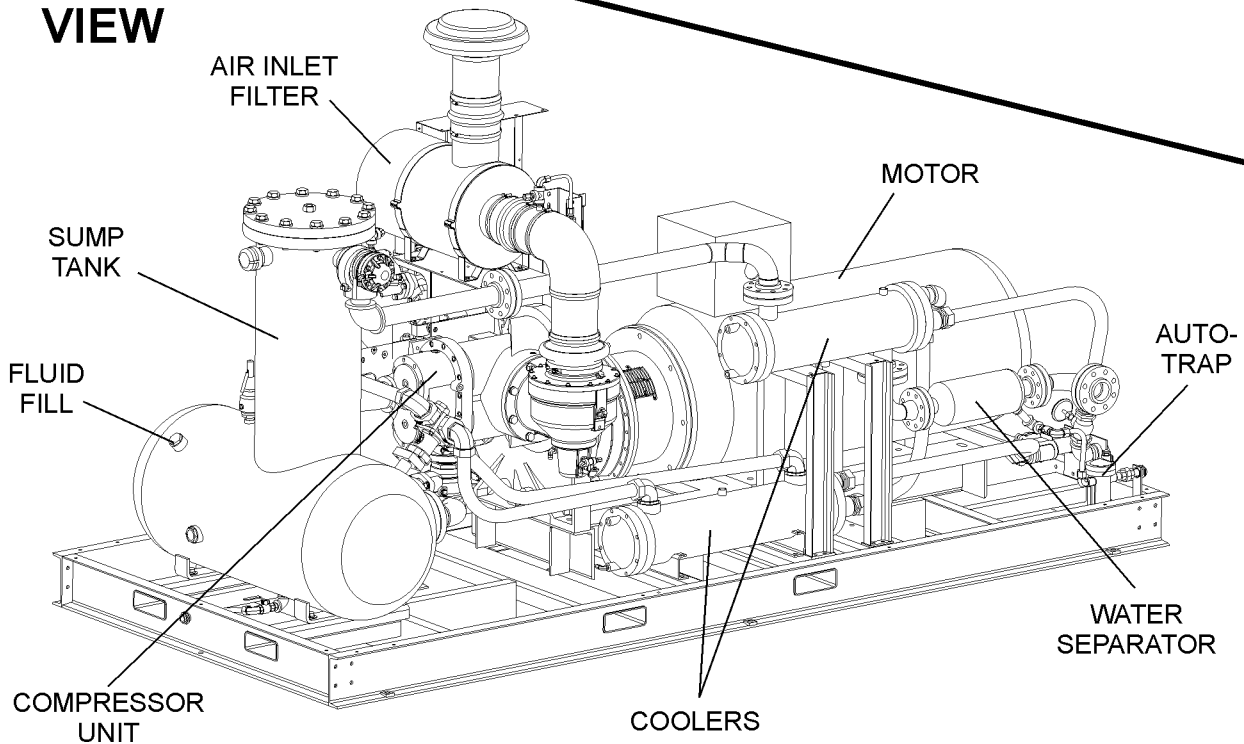

Section 2 DESCRIPTION

Figure 2-2 Compressor Cooling, Lubrication and Discharge System

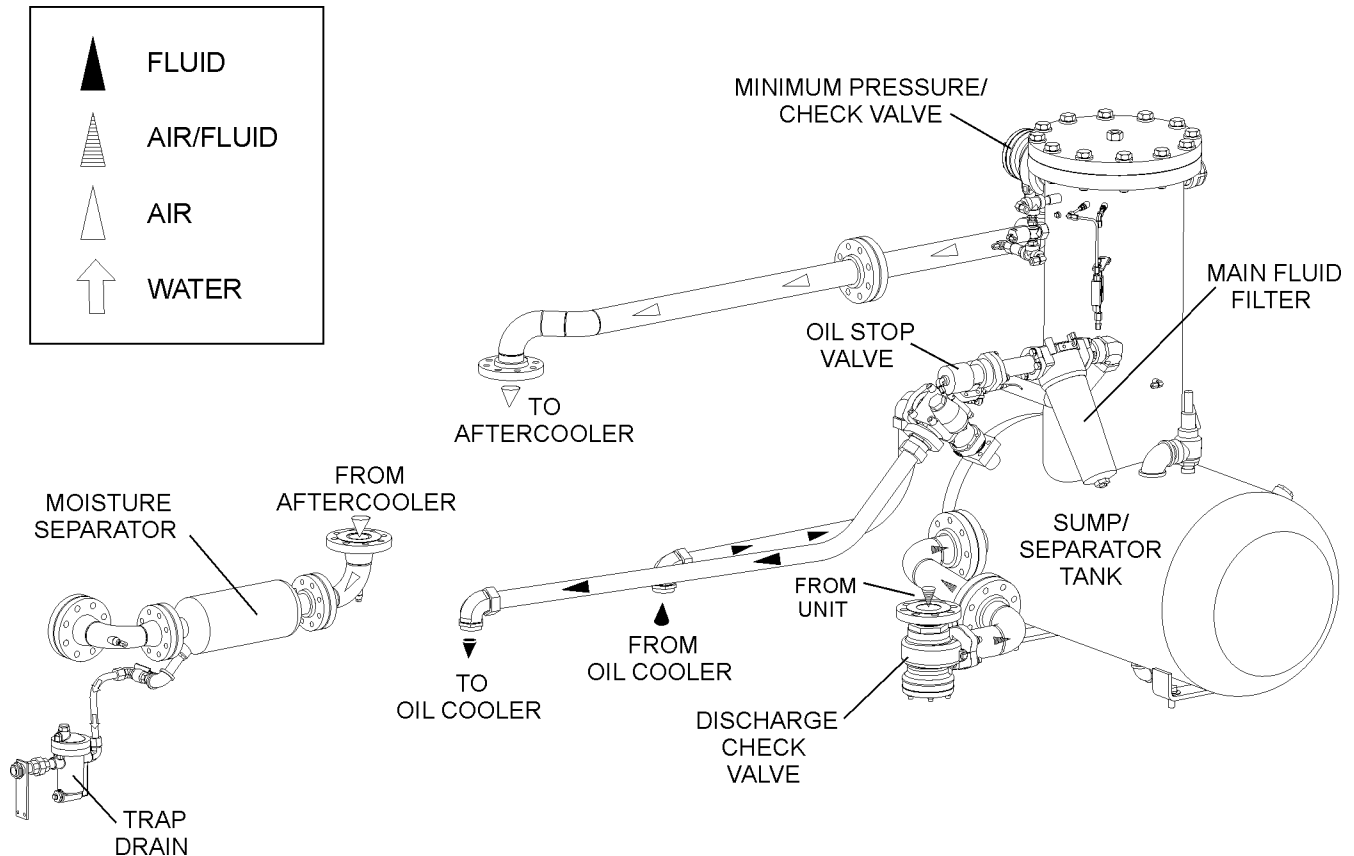

- Serves as the compressor fluid sump.

- Houses the final fluid separator elements.

The compressed air/fluid mixture enters the receiver and is directed against the ends of the tank. The direction of movement is changed and its velocity significantly reduced, thus causing large droplets of fluid to form and fall to the bottom of the receiver/sump. The fractional percentage of fluid remaining in the compressed air collects on the surfaces of the dual separator elements as the compressed air flows through them. Two return lines (or scavenge tubes) lead from the bottom of each separator element to the interstage of the compressor unit. Fluid collecting on the bottom of each separator is returned to the compressor by a pressure difference between the receiver and the compressor. Sight glasses are located in the return lines to observe this fluid flow. There are also orifices in this return line (protected by strainers) to assure proper

flow. By pressing the “**DSP**” pad on the Supervisor II, the operator may monitor the condition of the separator elements by reading differential pressure

on the digital display. At a differential of 10 psid (0.7 bar) or greater, the operator will be told to service the separator element. At this time, separator element replacement is necessary.

The receiver is an ASME pressure vessel. A combination minimum pressure/check valve, located downstream from the separator, assures a minimum receiver pressure of 160 psig (11bar) during full load operation. This pressure is necessary for proper air/fluid separation and proper fluid circulation while supplying air to the system. This valve also acts as a check valve preventing compressed air in the service line from bleeding back into the receiver on shutdown and during operation on the compressor in an unloaded condition.

A pressure relief valve (located on the wet side of the separator) is set to open at rated tank pressure.

The compressor is also equipped with high pressure shutdown protection to shut down at high MAX P1 setpoint. This prevents the relief valve from opening. High temperature probes are provided to shut down the compressor.

Section 2 DESCRIPTION



DO NOT remove caps, plugs, and/or other components when compressor is running or pressurized.

Stop compressor and relieve all internal pressure before doing so.

Fluid is added to the sump via a capped fluid filler opening, located on the tank to prevent overfilling of the sump. A sight glass enables the operator to visually monitor the sump fluid level.

2.6 CAPACITY CONTROL SYSTEM, FUNCTIONAL DESCRIPTION

Refer to Figures 2-3 and 2-4 (A through E). The purpose of the compressor control system is to regulate the compressor air intake to match the amount of compressed air being utilized. At 0 to 10 percent air output, the control system will automatically unload the compressor and reduce power consumption. The unload sump pressure can be set using the unload control regulator valve (150 psig/ 10.3 bar).

The **Control System** consists of an **inlet poppet valve, startup solenoid valve, reference (equalizing) pressure regulator, blowdown solenoid valve, pneumatic blowdown valve, control pressure regulator, unload pressure regulator, sequencing solenoid valve,** and a **control line filter** located prior to the controls.

The functional description of the Control System is described below in five distinct phases of the compressor operation. For explanation purposes, this description will apply to compressors with an operating range of 350 to 360 psig (24.1 to 24.8 bar). A compressor with any other pressure range would operate in a similar manner except for the stated pressures.

START MODE - TO 160 PSIG (11 BAR)

When the compressor start button is depressed, the pressure will rise from 0 to 160 psig (0 to 11 bar). During this period, the control inlet solenoid is closed, which keeps the inlet poppet valve closed. The control pressure regulator is also closed at this time. After the startup timer times out, the startup solenoid valve changes state and the reference pressure regulator controls the pressure signal to the poppet valve at a maximum 60 psig (4 bar). The inlet poppet valve opens allowing full airflow to the compressor inlet and the discharge pressure builds to approximately 160 psig (11 bar). No air is supplied to the system service line during this phase by the minimum pressure valve. When the

discharge pressure exceeds approximately 160 psig (11 bar), the minimum pressure valve may start to open and allow air to flow to the system service line.

NORMAL OPERATION MODE - 160 TO 350 PSIG (11 TO 24.1 BAR)

When the sump pressure rises above 160 psig (11 bar), the minimum pressure valve opens and delivers compressed air to the system service line. From this point on, a line air pressure transducer continually monitors the air pressure. The control pressure regulator valve remains closed during this phase, keeping the inlet poppet valve wide open. The blowdown solenoid valve also remains closed during this phase. Flow will occur when the discharge pressure is higher than the line pressure. The check valve, which is built into the minimum pressure valve, will prevent back flow into the compressor.

MODULATING MODE - 350 TO 360 PSIG (24.1 TO 24.8 BAR)

If less than the rated capacity of compressed air is being used, the system service line pressure will rise above 350 psig (24.1 bar). The control pressure regulator valve gradually opens applying air pressure to the control side of the inlet poppet valve, which modulates the position of the inlet poppet valve. This reduces the amount of air entering the compressor until it matches the amount of air being utilized. The control system functions continually in this manner, between the limits of 350 to 360 psig (24.1 to 24.8 bar) in response to varying demands from system service line. The control pressure regulator valve has an orifice, which vents a small amount of air to the atmosphere when the control pressure regulator valve modulates the inlet poppet valve.

UNLOAD MODE - EXCESS OF 360 PSIG (24.8 BAR)

As the required air is reduced, the discharge pressure and line pressure rise above the 360 psig (24.8 bar), the Supervisor II activates the unload solenoid valve which in turn pressurizes the blowdown valve. This opens the blowdown valve, which allows discharge air to flow back to the compressor inlet. Since the inlet poppet valve is fully closed, the air pressure from the sump tank will be relieved through the blowdown valve, which will reduce the sump pressure. Some of the outgoing air will flow directly into the compressor inlet to avoid cavitation during this time of blowdown. As the sump pressure drops, motor power consumption is also

Section 2 DESCRIPTION

reduced. The unload pressure regulator is set to maintain the unload pressure at the designated value, 150 psig (10.3 bar). At this time, the compressor is in the unload mode.

When the line pressure drops back to the load point (cut-in pressure) of the pressure transducer, usually 350 psig (24.1 bar), the compressor will change state back to the modulating mode as discussed earlier. This cycle will repeat itself, maintaining the demand required on the system line supply.

SHUTDOWN MODE

When the compressor is shut down based on a manual shutdown, a safety shutdown or an automatic shutdown from the Supervisor II touch pad, the unload solenoid valve is energized allowing air

to flow through the check valve and into the poppet valve keeping the inlet poppet valve closed. This also opens the blowdown valve to allow compressed air to vent back above inlet poppet valve through the inlet filter. The control lines are properly sized and routed to allow the compressed air to relieve to atmosphere rather than below the inlet poppet valve.

If the compressor Supervisor II is in the automatic mode, the compressor will shut down after running unloaded for a specific amount of time. The reverse also holds true, if the system line pressure requires additional compressed air, the compressor will start automatically to satisfy this demand.

Section 2 DESCRIPTION

Figure 2-3 Compressor Piping and Instrumentation Diagram- LS20TS 300-450 Water-cooled

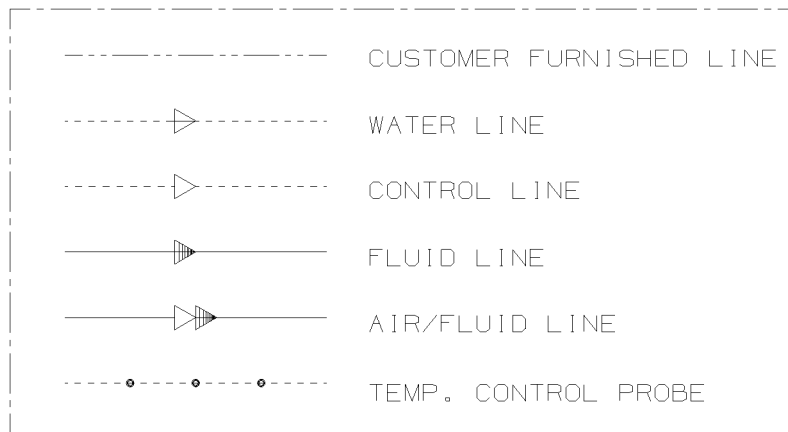
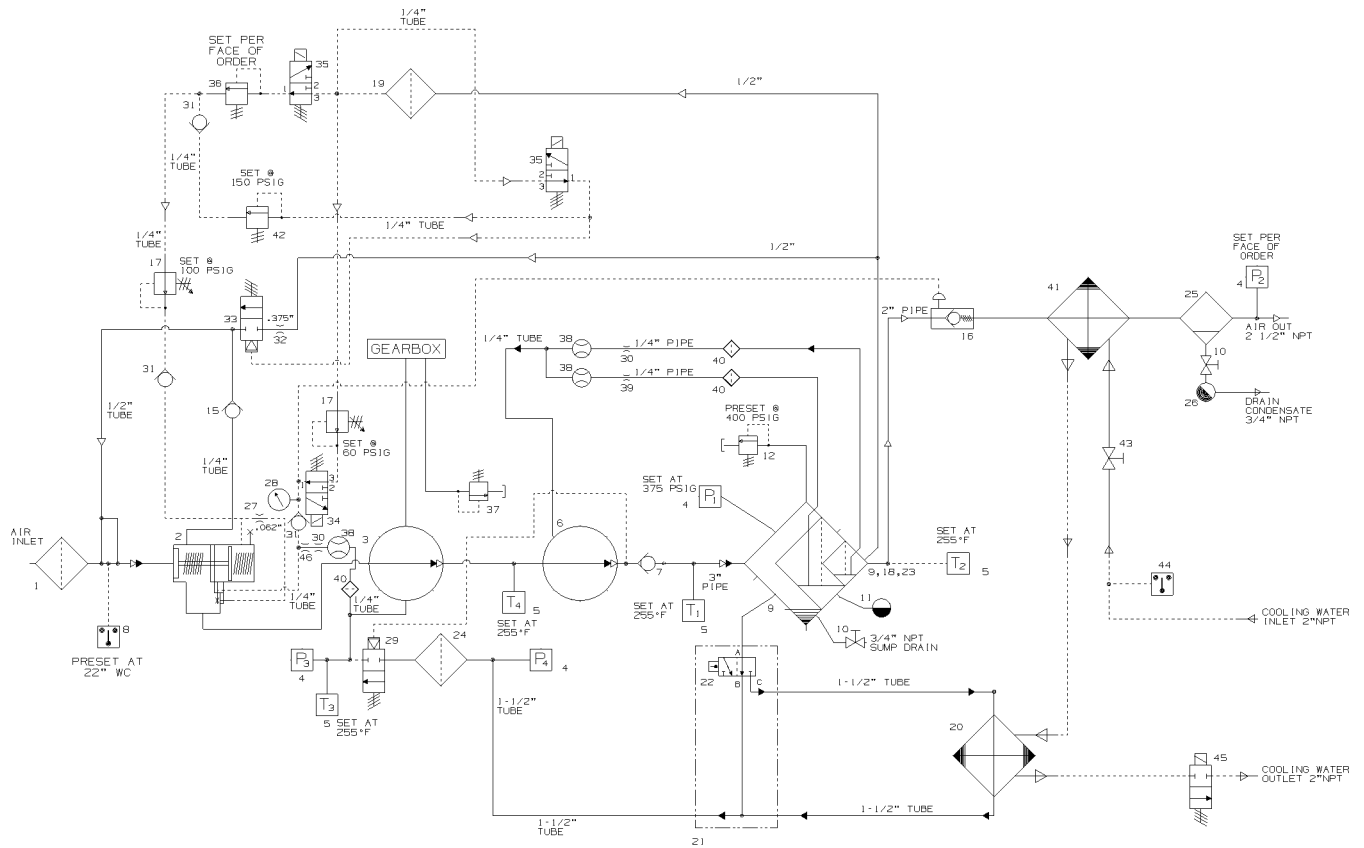

NOTES:

- PART NUMBERS ARE FOR REFERENCE ONLY, REFER TO BILL OF MATERIAL AND/OR FACE OF ORDER FOR ACTUAL PARTS.

Section 2 DESCRIPTION

Figure 2-3 Compressor Piping and Instrumentation Diagram- LS20TS 300/450 Water-cooled

key number	description	part number	quantity
1	filter, air	048456	1
2	valve, poppet	02250140-758	1
3	compressor, h.p. unit		1
4	xdcr,press 0-500# 1-5vdc n4	02250085-652	4
5	p,rtd 100 ohm	250039-909	4
6	compressor, h.p. stage		1
7	valve, discharge check	02250116-467	1
8	sw,vac 22"wc n4 6' cable	02250078-249	1
9	tank, sump	02250119-805	1
10	valve, ball 3/4" npt	02250117-792	2
11	glass, sight	02250097-611	1
12	valve, relief-400 psi	02250137-688	1
13	switch, high discharge pressure	245753	1
14	gauge, sump pressure	048061	1
15	valve,check 1/2"	042694	1
16	valve, minimum pressure	250031-852	1
17	regulator, down stream	02250139-030	2
18	element, separator primary	02250119-666	1
19	fltr, coalescing 425#	02250058-442	1
20	cooler, oil	02250139-060	1
21	valve, thermal assy	02250139-130	1
22	element,thermal vlv 230 degf	02250139-864	1
23	element, seperator secondary	02250119-667	1
24	filter, bearing oil	02250111-592	1
25	separator, water	406746	1
26	trap, drain	250006-639	1
27	orifice, .062" 1/4"m x 1/4"f	02250118-585	1
28	gauge, pressure	02250117-009	1
29	valve, oil stop	250041-069	1
30	orifice, 0.032"	02250125-774	2
31	valve, check	02250110-557	3
32	restrictor, pipe .375" dia	866406-000	1
33	valve, running blowdown n.c.	045116	1
34	valve, solenoid 3-way n.o.	02250125-657	1
35	valve, solenoid 3-way n.o.	407390	2

(Continued on page 13)

Section 2 DESCRIPTION

Figure 2-3 Compressor Piping and Instrumentation Diagram- LS20TS 300/450 Water-cooled

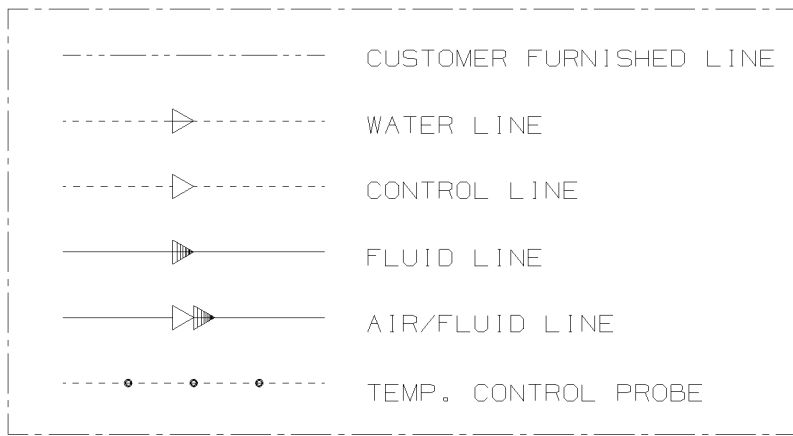
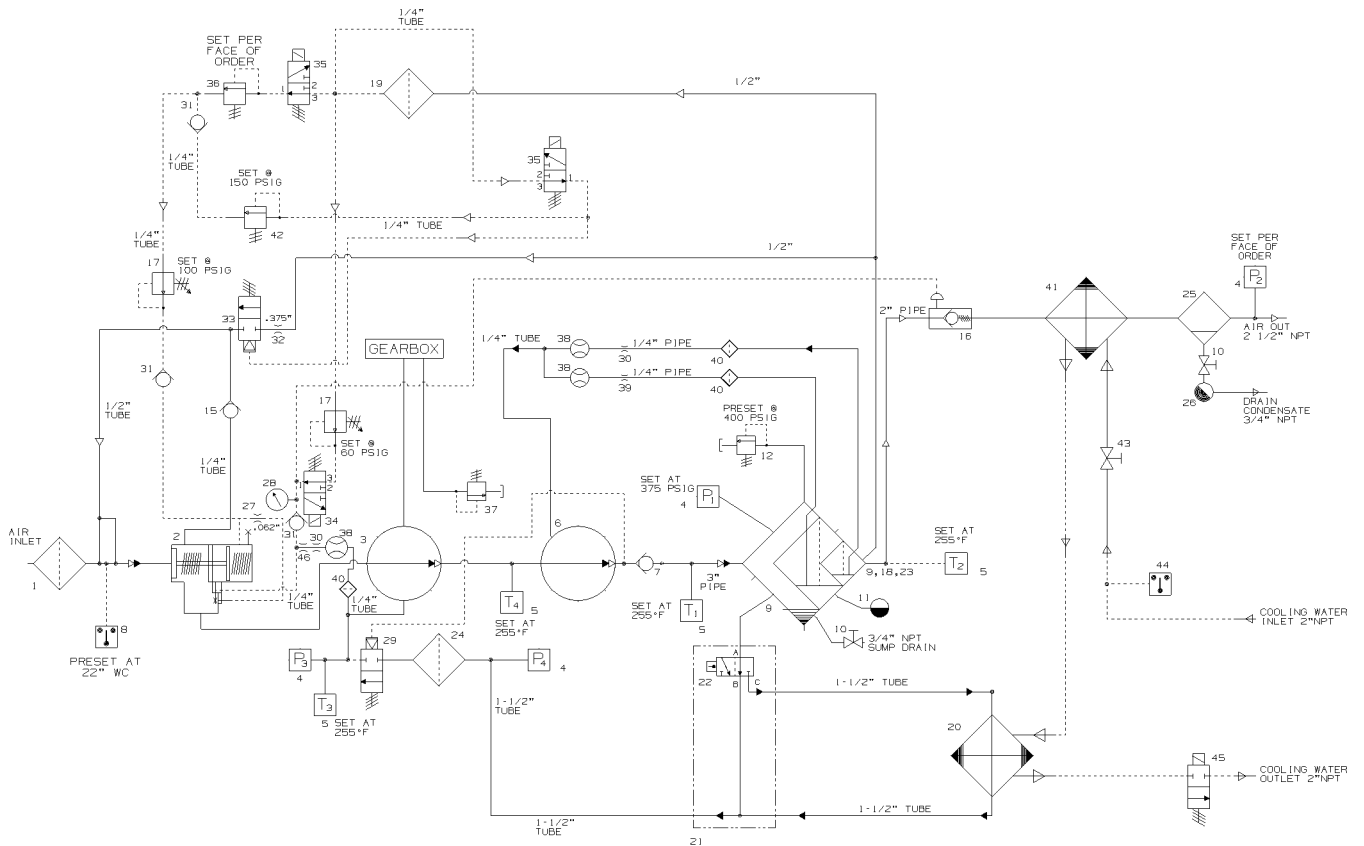

NOTES :

1. PART NUMBERS ARE FOR REFERENCE ONLY, REFER TO BILL OF MATERIAL AND/OR FACE OF ORDER FOR ACTUAL PARTS.

Section 2 DESCRIPTION

Figure 2-3 Compressor Piping and Instrumentation Diagram- LS20TS 300/450 Water-cooled (continued)

key number	description	part number	quantity
36	regulator, back pressure	048059	1
37	valve, relief gearbox-150psi	040647	1
38	glass, sight	02250126-129	3
39	orifice, 3/32"	02250125-776	1
40	strainer, oil return	02250117-782	3
41	aftercooler, air	02250139-059	1
42	valve, pressure regulator	045099	1
43	valve,globe 2"	042281	1
44	switch,press no 10 psi	250017-992	1
45	valve,solenoid 2way nc	408994	1
46	orf,.032" 1/4m x 1/4m	02250101-191	1

Section 2 DESCRIPTION

Figure 2-4A Control System Diagram- Functional Components

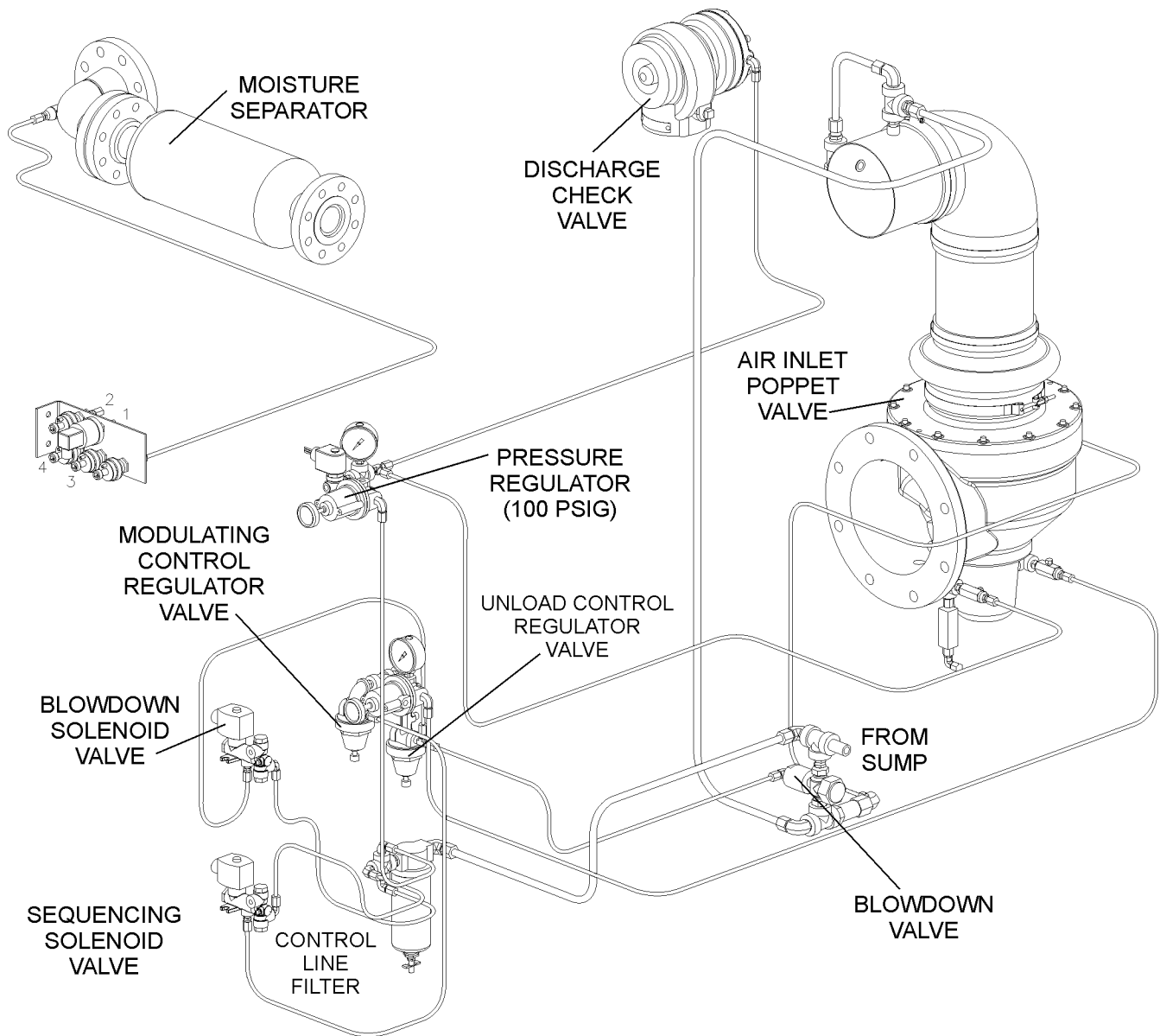



LEGEND:
 1 - TO INLET FILTER
 2 - TO FLUID FILTER INLET
 3 - TO WET SIDE SUMP
 4 - TO UNIT FLUID INJECTION BLOCK

Section 2 DESCRIPTION

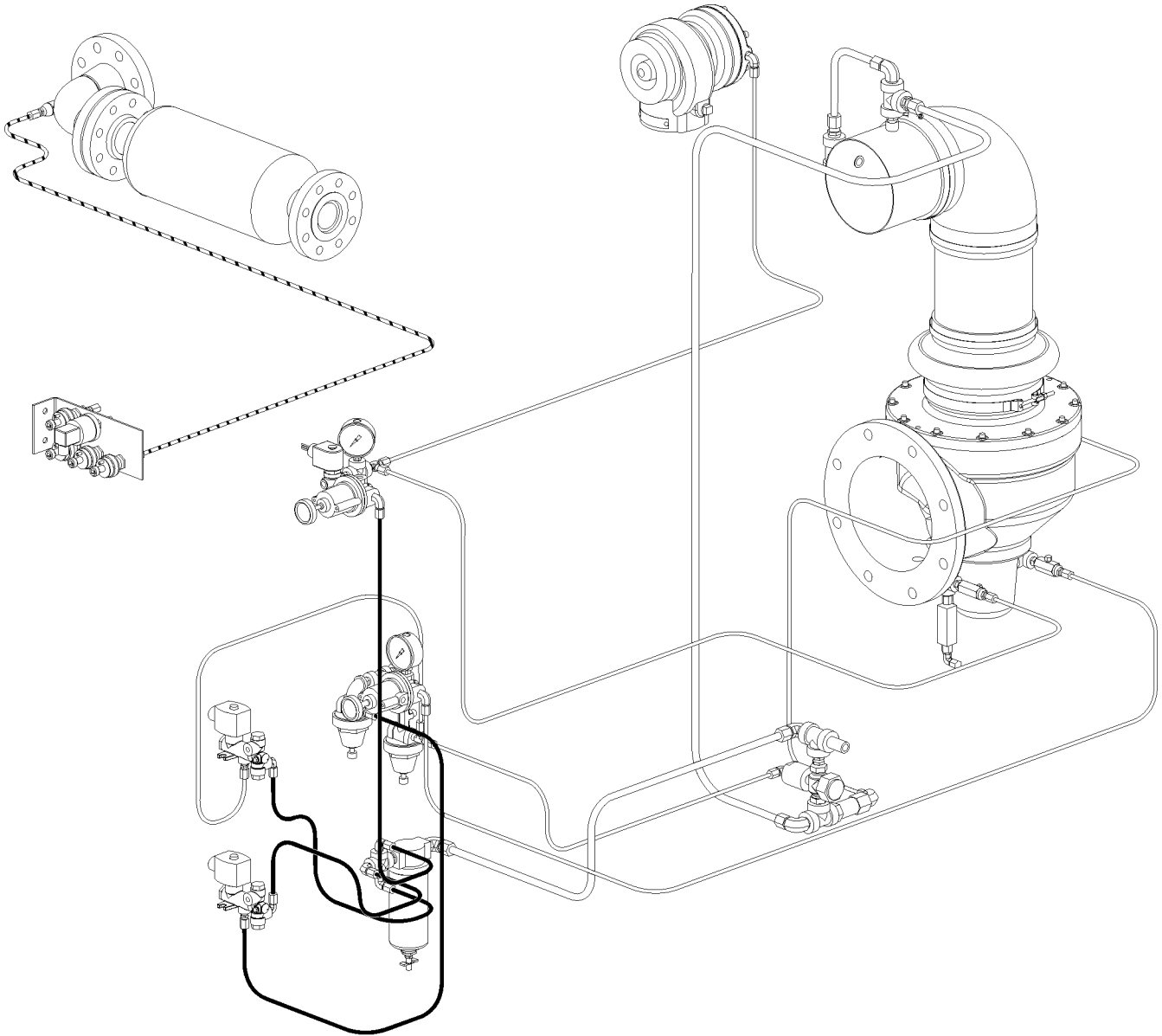
Figure 2-4B Control System Diagram- START





-  Line Pressure Air
-  Dry Side Air
-  Regulated Air

Section 2 DESCRIPTION

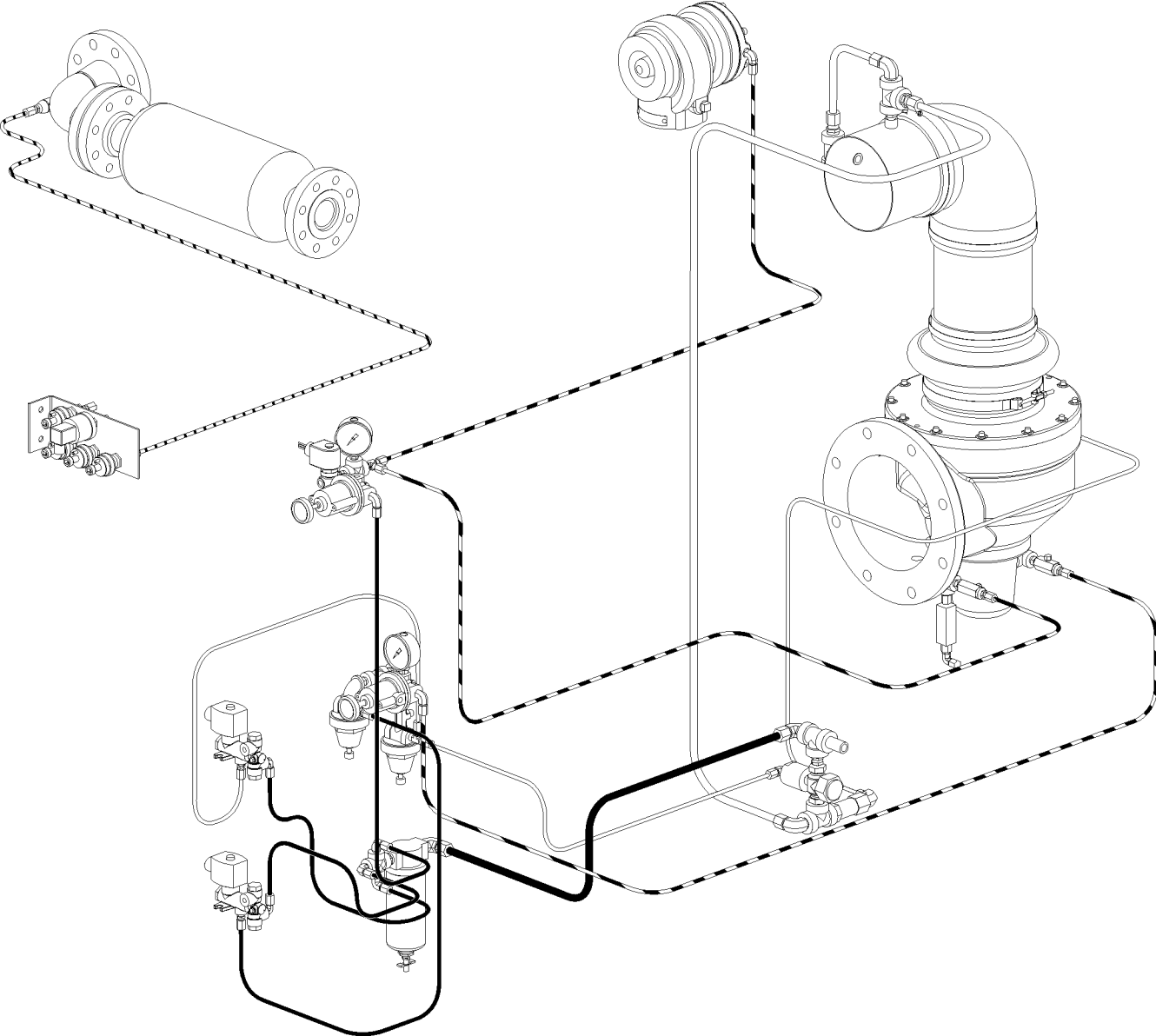
Figure 2-4C Control System Diagram- MODULATION



-  Line Pressure Air
-  Dry Side Air
-  Regulated Air

Section 2 DESCRIPTION

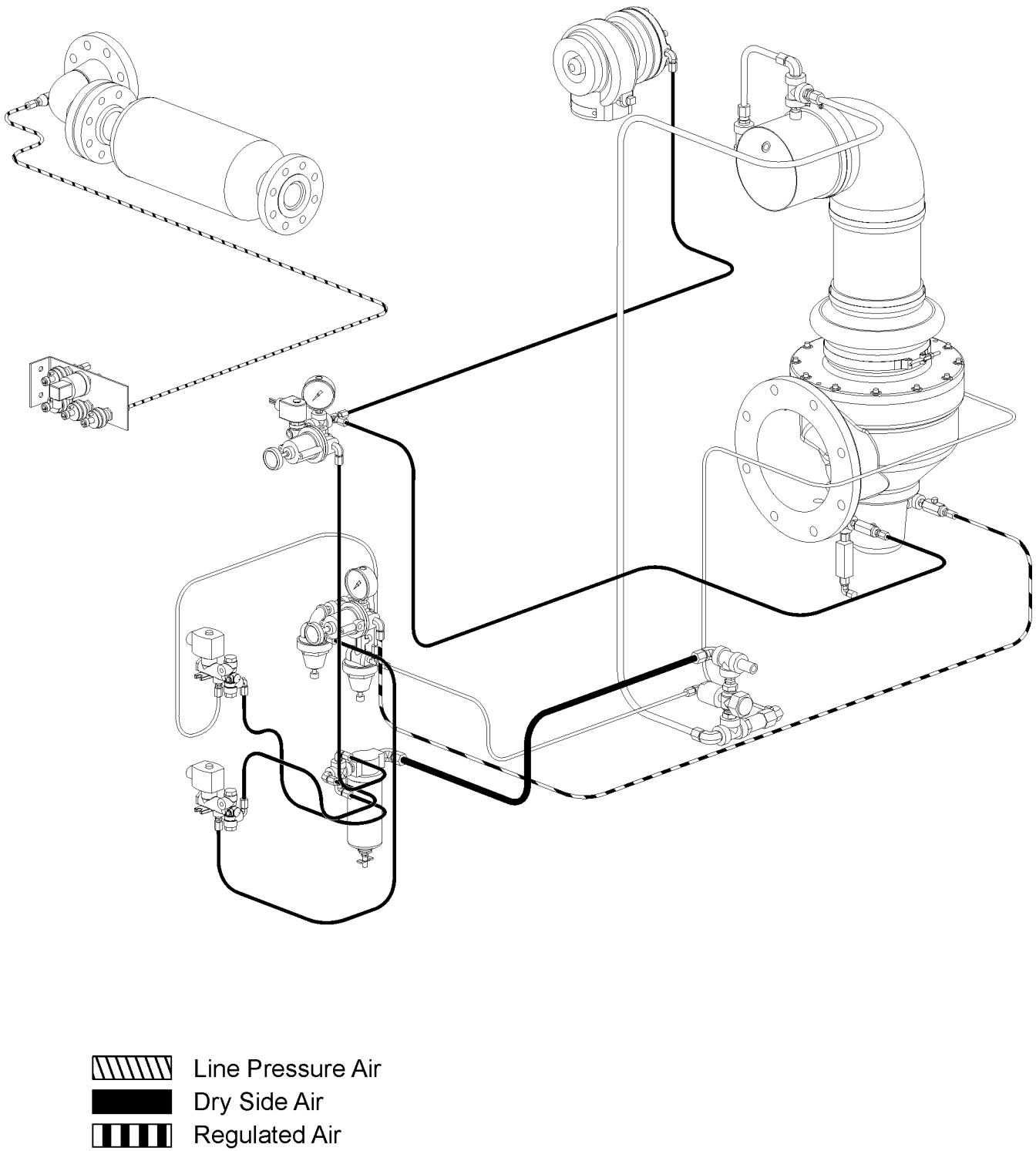

Figure 2-4D Control System Diagram- FULL LOAD

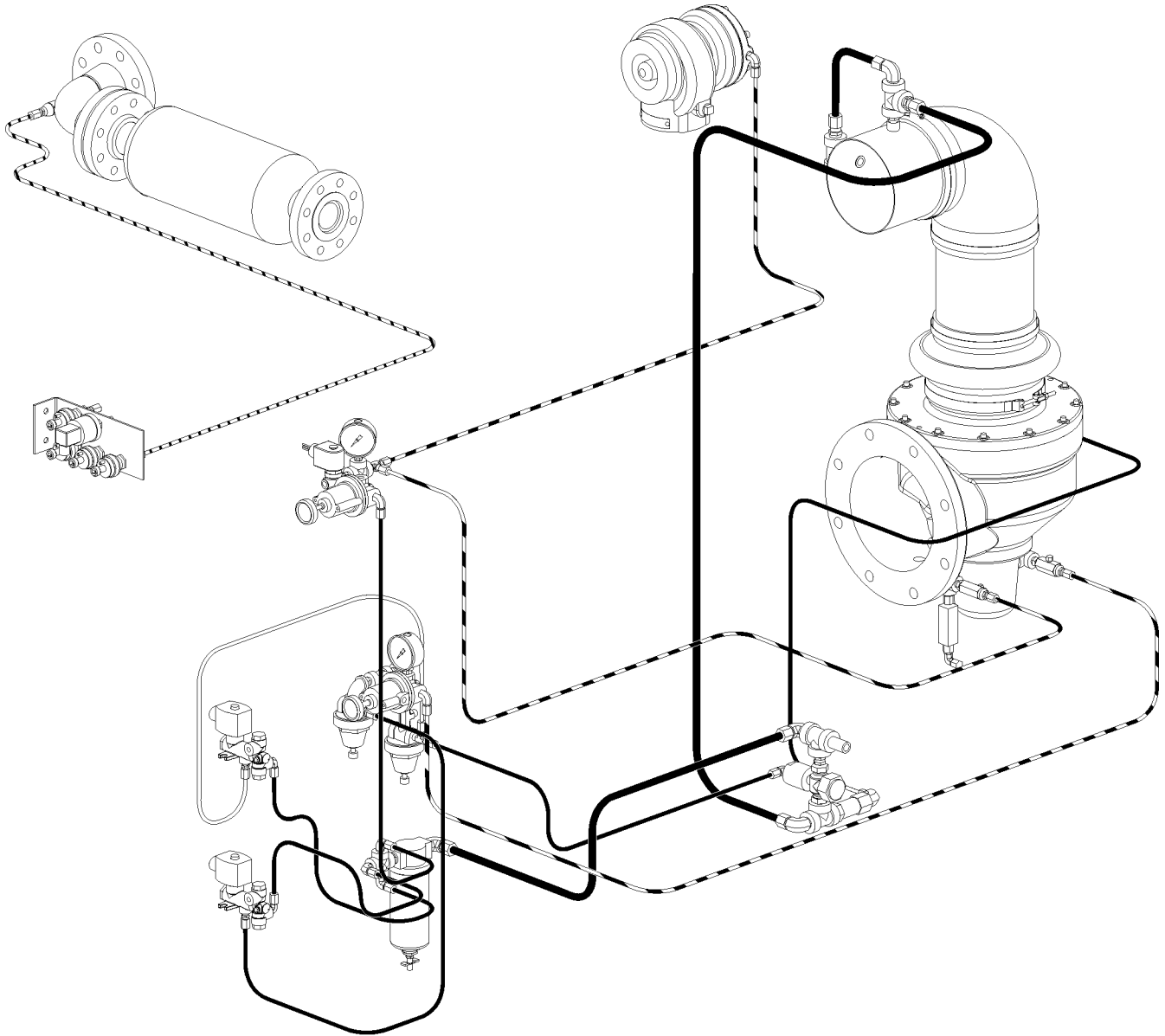

Section 2 DESCRIPTION

Figure 2-4E Control System Diagram- UNLOAD



-  Line Pressure Air
-  Dry Side Air
-  Regulated Air

Section 2 DESCRIPTION

2.7 AIR INLET SYSTEM, FUNCTIONAL DESCRIPTION

Refer to Figure 2-5. The **Compressor Inlet System** consists of a **dry-type air filter**, a **vacuum switch**, and an **air inlet valve**.

At 20" water column the inlet vacuum switch will allow the Supervisor II to indicate that "AIR FILTER MAINT RQD" is required.

The poppet-type air inlet valve directly controls the amount of air intake to the compressor in response to the operation of the controls (see Section 2.6, Control System, Functional Description).

2.8 SUPERVISOR II PANEL BASIC INTRODUCTION

Refer to Figure 2-6. The Supervisor II has a two line display to show temperature, pressure and status. It has a keypad for operating the compressor, programming the control points and selecting displays. There is a graphic illustration with lamps that light to show the item being displayed. The lamps flash if that component is in an alarm condition.

2.9 KEYPAD

The keypad is used to control the machine as well as display status and change setpoints. Refer to Figure 2-6 for following key descriptions.

- **Stop** - Used to put the machine into manual stop. It is also used to clear alarm conditions.



- **Continuous** - Starts machine if no alarm conditions are present. Also used to clear alarm conditions while machine is running.



- **Auto** - Starts machine and selects auto mode if no alarm conditions are present. Also used to clear alarm conditions while machine is running.



- **Display** - Used to display pressures, temperatures and other status information (See section on STATUS DISPLAYS).



Figure 2-5 Air Inlet System

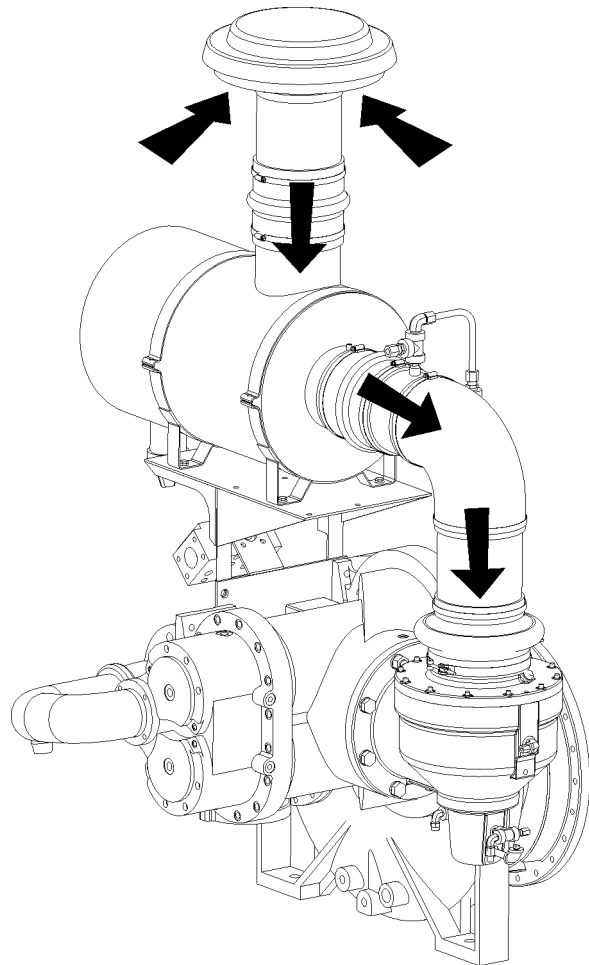

- **Logo** - Used for various functions described in later sections.



- **Program** - Used to enter the parameter change mode where control parameters may be displayed and changed (See PARAMETER SETUP).



- **Up arrow** - Used in status displays to change displays and in parameter setup mode to increment a value.



- **Down arrow, lamp test** - Used in status dis-

Section 2 DESCRIPTION

Figure 2-6 Supervisor II Panel

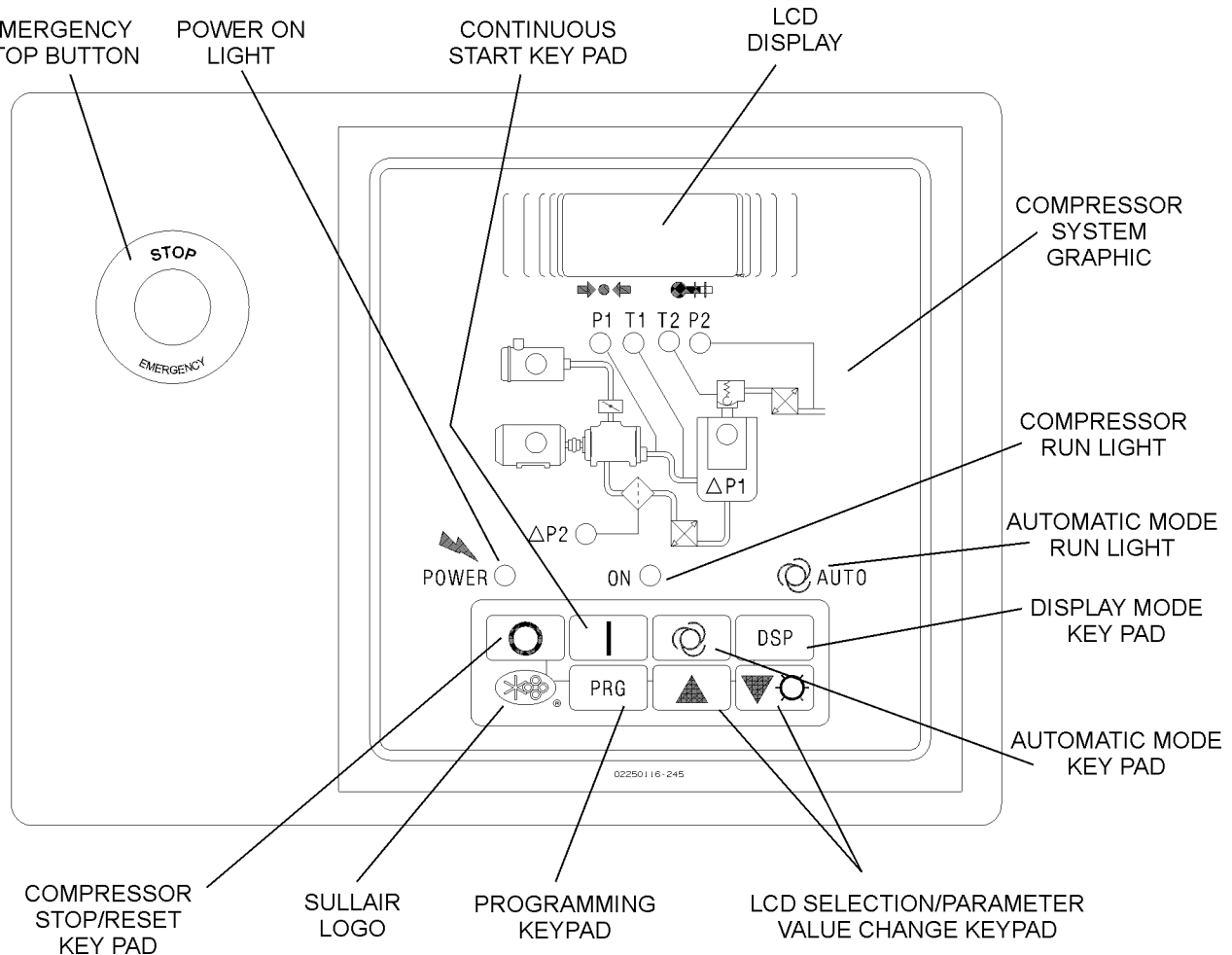

plays to change displays and in parameter setup mode to increment a value. When in the default display the key will light all the lamps for three seconds.



2.10 STATUS DISPLAYS

By default the line pressure (P2) and discharge temperature (T1) are shown on the bottom line of the display, and machine status on the top line.

The following are the various machine status messages that indicate the state of the compressor:

(Display graphics shown below.)

- **STOP** - Compressor is off.
- **STANDBY** - Compressor is off but armed to start. This state may be entered because of a power up, or the unload timer had expired and stopped the machine.

NOTE

The machine may start at any time.

- **STARTING** - Machine is trying to start.
- **OFF LOAD** - Machine is running and off loaded.
- **ON LOAD** - Machine is running and loaded.
- **FULL LD** - Machine is running and fully loaded. This state is only displayed if the machine has a full load valve.
- **RMT STOP** - Compressor is off but armed to start. The machine will start when the remote start contact is closed.

NOTE

The machine may start at any time.

- **SEQ STOP** - Compressor is off but armed to start. The machine will start when the

Section 2 DESCRIPTION

sequencing conditions meet the criteria to start.

NOTE

The machine may start at any time.

This default display appears as follows:

STOP
360 220

If there are alarms active they will alternately be shown with the default display. The machine status will be displayed for 2 seconds then the alarms for 2 seconds each. For example:

T1 HI
360 220

To view other status press the DSP key. All temperatures and pressures may be displayed as well as other status information. To scroll through the displays press the up arrow or down arrow keys. Up arrow moves to the next display, down arrow the previous display. To return to the default display press the display key.

- Separator differential pressure and the maximum limit. If the limit is exceeded, a separator maintenance warning will be displayed.

dP1 4
MAX 10

- Sump pressure and line pressure.

P1 363
P2 358

- Oil filter differential pressure and the maximum limit. If the limit is exceeded oil maintenance warning will be displayed.

dP2 4
MAX 20

- Pressure before (P4) and after (P3) oil filter.

P3 290
P4 295

- Oil differential pressure and the minimum limit. If the pressure goes below the limit a

P3 LOW shutdown will occur. Oil differential (dP3) is defined as P3-P1/2

dP3 40
MIN 1

- Unit discharge temperature and the maximum limit. If the temperature exceeds the limit a T1 HI shutdown will occur.

T1 210
MAX 255

- Dry side discharge temperature and the maximum limit. If the temperature exceeds the limit a T2 HI shutdown will occur.

T2 210
MAX 255

- Oil temperature and the maximum limit. If the temperature exceeds the limit a T4 HI shutdown will occur.

T4 210
MAX 255

- Total hours that the compressor has been running.

HRS RUN
001234.0

- Total hours that the compressor has been loaded.

HRS LOAD
000987.0

- Last fault log. This shows the fault on the first line and the run hours when the fault occurred.

T1 HI
@1 255

- Next to last fault log. This shows the fault on the first line and the run hours when the fault occurred.

T1 HI
@2 224

Section 2 DESCRIPTION

2.11 LAMP INDICATORS

Embedded into the front panel schematic of the compressor are several lamps. Pressing the lamp test key will light all the lamps for 3 seconds. Each LED lamp has the following purpose.

P1 - (Line pressure) If lit steady, signifies that P1 is being displayed, if flashing denotes the presence of an alarm.

P2 - (Sump pressure) If lit steady, signifies that P2 is being displayed, if flashing denotes the presence of an alarm.

P3 - Injection oil pressure (Pressure after oil filter) Same as P1 & P2 except for P3.

P4 - (Pressure before oil filter)

dP1 - (Separate differential pressure) If lit steady, signifies that DP1 is being displayed, if flashing denotes replacement of separator is needed.

dP2 - (Oil filter differential pressure)

dP3 - (Oil differential pressure)

T1 - (Dry side discharge temperature) If lit steady, signifies that T1 is being displayed, if flashing denotes the presence of an alarm.

T2 - (Discharge temperature) If lit steady, signifies that T2 is being displayed, if flashing denotes the presence of an alarm.

T3 - (Oil temperature) If lit steady, signifies that T3

is being displayed. For monitoring only.

T4 - (Interstage temperature) If lit steady, signifies that T4 is being displayed, if flashing denotes the presence of an alarm.

NOTE

For T1, T2 and T4, shutdown points are at 255°F (124°C) with a 30 second delay, and 275°F (135°C) immediate.

MOTOR - If flashing, indicates the motor overload contact has opened.

INLET FILTER - If flashing, indicates that inlet filter maintenance is needed.

OIL FILTER - If flashing, indicates that oil filter maintenance is needed.

POWER ON - Lit if 120VAC power is applied to the Supervisor II.

ON - If lit steady, the compressor is running. If flashing, indicates that the compressor is armed but stopped because of restart timer not expired, remote stop or sequence stop. The compressor may start at any time.

AUTO - If lit steady, the compressor is running and in auto mode. If flashing, indicates that the compressor is armed but stopped because of restart timer not expired, remote stop or sequence stop. The compressor may start at any time.

Section 3 SPECIFICATIONS

3.1 SPECIFICATIONS- LS20TS

Model Series	DIMENSIONS WITHOUT ENCLOSURE (I)						Weight	
	Length		Width		Height		lb	kg
	in	mm	in	mm	in	mm		
LS20TS 800 CFM	157.00	3988	71.69	1821	92.09	2339	(II)	(II)
LS20TS 960 CFM	157.00	3988	71.69	1821	92.09	2339	(II)	(II)

(I) For information concerning enclosed compressors, please contact the Sullair Factory Sales Department.

(II) For information concerning compressor weight, please contact the Sullair Factory Sales Department.

NOTE

For noise level information, please contact the Sullair Factory Service Department.

COMPRESSOR:

Type:	2-Stage Oil Flooded Rotary
Maximum Full Load Operating Pressure:	350 psig (24.1 bar)
Bearing Type:	Anti-Friction
Cooling:	Pressurized Compressor Fluid
Lubricant:	Sullube
System Fluid Capacity (refill):	50 U.S. Gallons (189.3 Liters)
Control:	Supervisor II Controller

MOTOR:

Type:	O.D.P., 460V, A.C., Three Phase, 60 Cycles
Size:	300, 350, 400 and 450HP
Speed:	1800 RPM

3.2 LUBRICATION GUIDE-STANDARD COMPRESSORS

Refer to Figure 3-1 for fluid fill port location. Sullair standard compressors are filled with Sullube fluid as factory fill.

⚠ WARNING

To be sure that you receive the correct fluid for your compressor, when ordering fluid, always confirm your compressor's fluid fill with the parts technician by using your compressor's serial number.

⚠ WARNING

Mixing of other fluids within the compressor will void all warranties.

Sullube fluid should be changed every 1800 hours or once a year, whichever comes first. The fluid should be changed more frequently under severe operating conditions, such as high ambient temperatures coupled with high humidity, or when high particulate level, corrosive gases or strong oxidizing gases are present in the air.

Figure 3-1 Fluid Fill Port Location

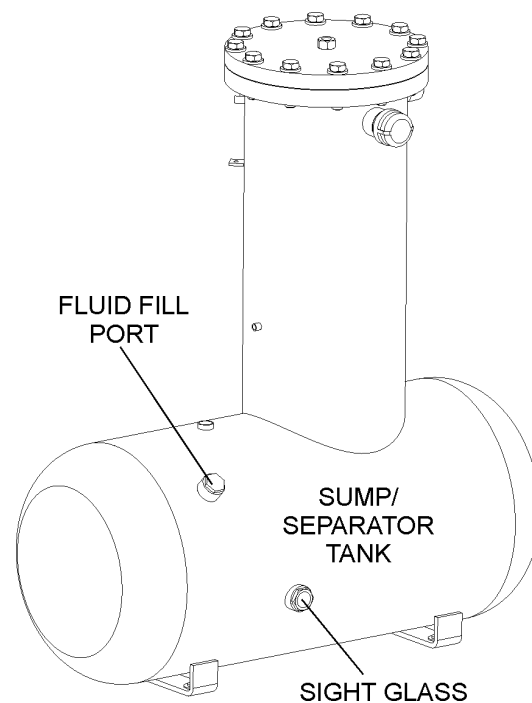

Section 3

SPECIFICATIONS

Maintenance of all other components is still recommended as indicated in the Operator's Manual.



Mixing of other lubricants within the compressor unit will void all warranties

“The Plastic Pipe Institute recommends against the use of thermoplastic pipe to transport compressed air or other compressed gases in exposed above ground locations, e.g. in exposed plant piping.” (I)

Sullube should not be used with PVC piping systems. It may affect the bond at cemented joints. Certain other plastic materials may also be affected.

(I) Plastic Pipe Institute, Recommendation B, Adopted January 19, 1972.

3.3 APPLICATION GUIDE

Sullair encourages the user to participate in a fluid analysis program with the fluid suppliers. This could result in a fluid change interval differing from that stated in the manual. Contact your Sullair dealer for details.

Section 3 SPECIFICATIONS

Figure 3-2 Identification- LS20TS 300-450 Water-cooled (Including Spiral Valve and Enclosure)

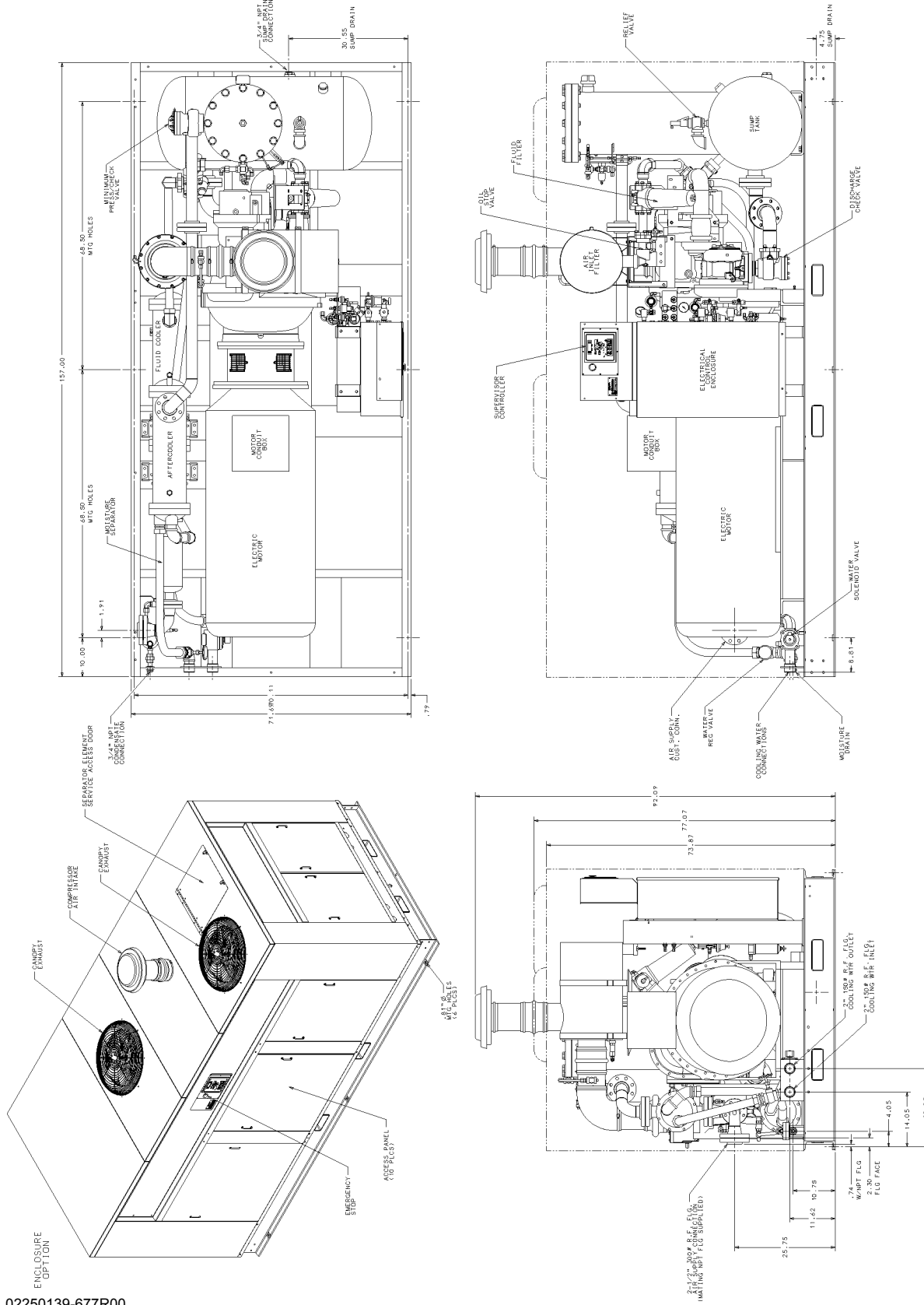

INSTALLATION NOTE
 1. FOUNDATION OR MOUNTING CAPABLE OF SUPPORTING THE WEIGHT () OF THE MACHINE AND RIGID ENOUGH TO MAINTAIN THE COMPRESSOR FRAME LEVEL AND THE COMPRESSOR IN ALIGNMENT IS REQUIRED. THE COMPRESSOR FRAME MUST BE LEVELED AND SECURED WITH FOUNDATION BOLTS, AND FULL UNIT-FRAME CONTACT MUST BE MAINTAINED BETWEEN THE FRAME AND TO THE FOUNDATION. NO FIELD LADS SHALL BE TRANSMITTED TO THE MACHINE BY EXTERNAL CONNECTIONS.

- NOTES:
1. ALLOW 4-FT. MIN. CLEARANCE ALL AROUND.
 2. FRAME MOUNTING HOLES ARE 8 1/4" Ø (6 PLS.).
 3. ENCLOSURE ACCESS PANELS/DOORS ARE REMOVABLE.
 4. FOR SERVICING: ARE IN INCHES (± .50" TOLERANCE).
 5. ALL DIMENSIONS ARE SERVING ELEMENTS.

02250139-677R00

Section 3 SPECIFICATIONS

Figure 3-3 Identification- LS20TS 300-450 Water-cooled Supervisor II Deluxe

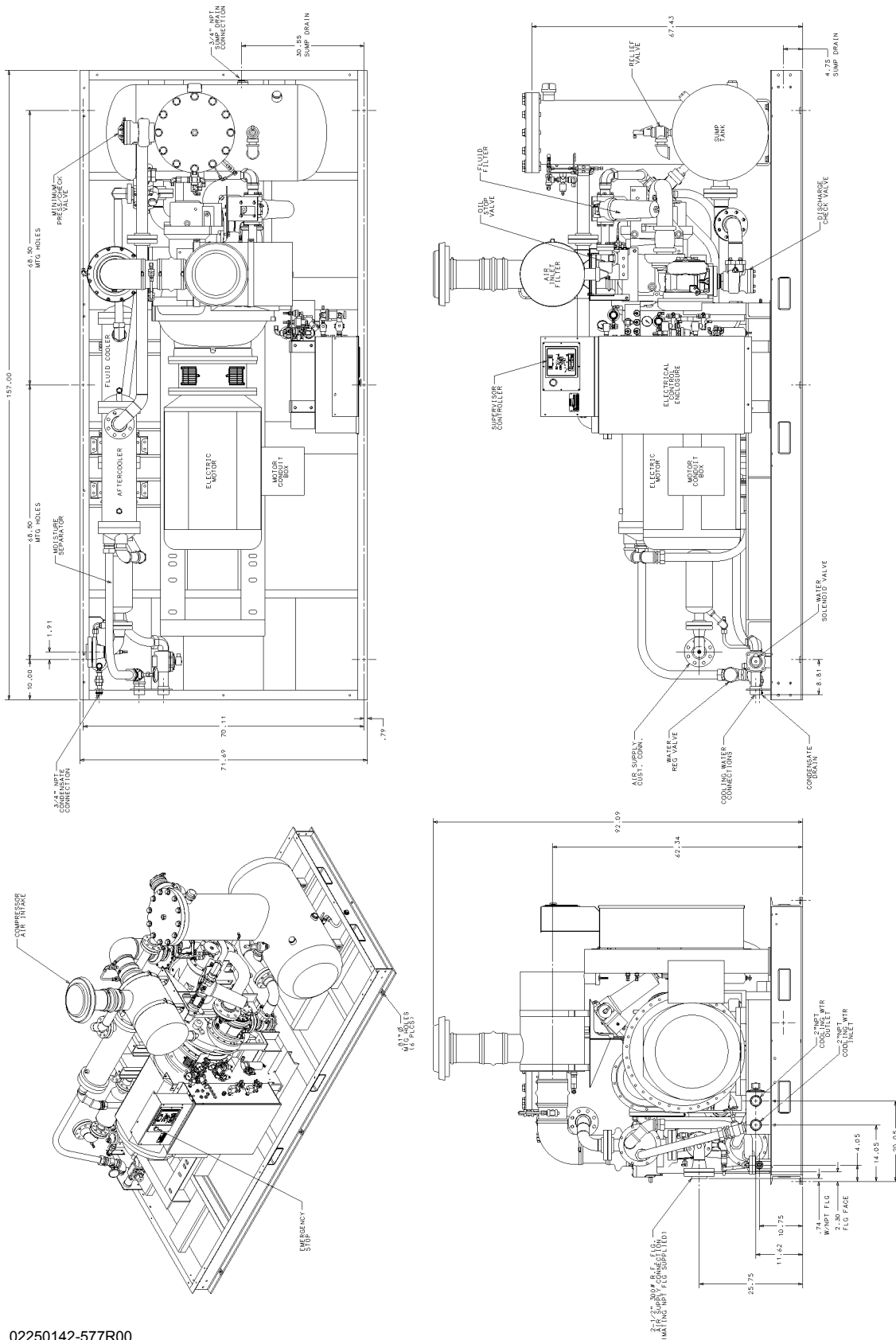

INSTALLATION NOTE
A FOUNDATION OR MOUNTING CAPABLE OF SUPPORTING THE WEIGHT (#) OF THE MACHINE AND RIGID ENOUGH TO MAINTAIN THE COMPRESSOR FRAME LEVEL AND THE COMPRESSOR IN ALIGNMENT IS REQUIRED. THE COMPRESSOR FRAME MUST BE LEVELLED AND SECURED WITH FOUNDATION BOLTS AND FULL UNIFORM CONTACT MUST BE MAINTAINED BETWEEN THE FRAME AND FOUNDATION. IT IS RECOMMENDED THAT THE FRAME BE GROUTED TO THE FOUNDATION. NO PIPING LOADS SHALL BE TRANSMITTED TO THE MACHINE BY EXTERNAL CONNECTIONS.

- NOTES:
1. ALLOW 4 FT. MIN. CLEARANCE ALL AROUND.
 2. FRAME MOUNTING HOLES ARE $8.11" \text{ } \varnothing$ (6 PLCS.).
 3. ALL DIMENSIONS ARE IN INCHES, $\pm .50"$ TOLERANCE.

02250142-577R00

Section 4 INSTALLATION

4.1 MOUNTING OF COMPRESSOR

A foundation or mounting capable of supporting the weight of the compressor, and rigid enough to maintain the compressor frame level and the compressor in alignment is required. The compressor frame must be leveled and secured with foundation bolts, and full uniform contact must be maintained between the frame and foundation. It is recommended that the frame be grouted to the foundation. The compressor unit and driver must be aligned after installation as specified in this Operator's Manual. No piping loads shall be transmitted to the compressor or the cooling package at the external connections.

4.2 VENTILATION AND COOLING

For air-cooled compressors, select a location to permit sufficient unobstructed air flow in and out to the compressor to keep the operating temperature stable. The minimum distance that the compressor should be from surrounding walls is 4 feet/1.22m. To prevent excessive ambient temperature rise, it is imperative to provide adequate ventilation.

For water-cooled compressors, it is necessary to check the cooling water supply. The water system must be capable of supplying the following flows:

MODEL-HP/KW	WATER FLOW (GPM)
LS20TS-300- 300HP/224KW	54
LS20TS-350- 350HP/261KW	65
LS20TS-400- 400HP/298KW	76
LS20TS-450- 450HP/336KW	80

NOTE

Water flow requirements are based on 80°F to 85°F (27°C to 29°C) water inlet temperature.

Recommended water pressure range is 40 to 75 psig (2.8 to 5.2 bar). Water flow rates will vary with operating conditions. For rates based on criteria other than that listed, consult your local Sullair representative.

Table 4-1 Ventilation Requirements indicates the ventilation requirements necessary to keep the compressor running at a normal operating temper-

Table 4-1 Ventilation Requirements

		WATER COOLED OR REMOTE COOLED COMPRESSOR PACKAGE		AIR-COOLED (I) COOLING PACKAGE (REMOTE)	
MODEL	MOTOR HP/KW	HEAT REJECTION BTU/HR	VENT FAN FLOW (II) CFM	HEAT REJECTION BTU/HR	AIR FLOW CFM
LS20TS-300	300/224	80,136	2,800		
LS20TS-350	350/261	89,000	2,800		
LS20TS-400	400/298	110,400	2,800		
LS20TS-450	450/336	110,400	2,800		

(I) Applicable to air-cooled models only.

(II) Applicable to compressors with enclosure.

ature. The fan air requirement is the volume of air which must flow through the compressor for proper ventilation. The specified heat rejection requirement is the amount of heat that is radiated by the compressor. This heat must be removed to assure a normal operating temperature. With air-cooled compressors it is possible to use this heat for space heating, providing excessive pressure drop is not created across the fan. Consult a Sullair office for assistance in utilizing this heat.

DO NOT install a water-cooled or an air-cooled/aftercooled compressor without adequate freeze protection where it will be exposed to temperature less than 32°F(0°C).

4.3 SERVICE AIR PIPING

Service air piping should be installed as shown in Figure 4-1, which shows a typical arrangement. A shut-off valve should be installed to isolate a compressor from the service line if required. Also notice that the service line should be equipped with water legs and condensate drains throughout the system.

WARNING

“The Plastic Pipe Institute recommends against the use of thermoplastic pipe to transport compressed air or other compressed gases in exposed above ground locations, e.g. in exposed plant piping.” (I)

Sullube should not be used with PVC piping systems. It may affect the bond at cemented joints. Certain other plastic materials may also be affected.

(I) Plastic Pipe Institute, Recommendation B, Adopted January 19, 1972.

4.4 COUPLING ALIGNMENT CHECK

In preparation for the factory test, the coupling supplied with your compressor is properly aligned for operation. The motor is flange-mounted to the compressor unit adapter. Therefore, it is not necessary to check this alignment, unless high vibration is noticed.

4.5 FLUID LEVEL CHECK

Your air compressor is also supplied with the prop-

Section 4 INSTALLATION

Figure 4-1 Service Air Piping (Typical)

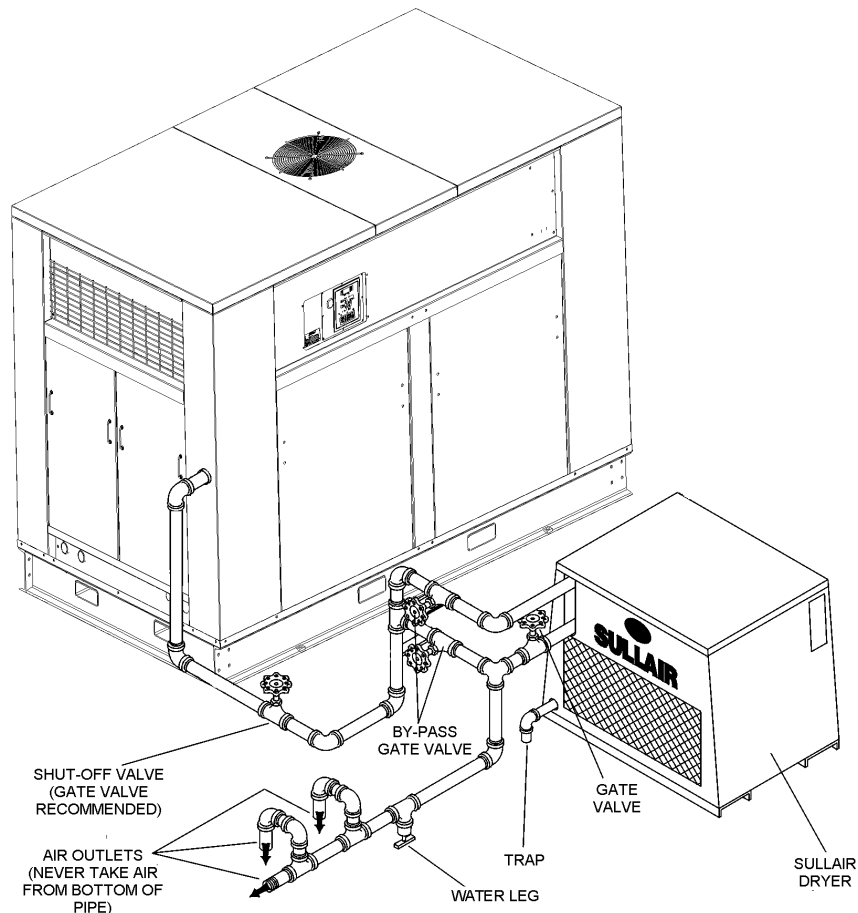

er amount of fluid. However, it is necessary to check the fluid level at installation. The level is checked by looking at the sight glass located on the sump. If the sump is properly filled, the coolant level MAX should fill 1/2 of the sight glass when the compressor is running.

4.6 ELECTRICAL PREPARATION

Interior electrical wiring is performed at the factory. Required customer wiring is minimal, but should be done by a qualified electrician in compliance with any applicable regional or local electrical code concerning isolation switches, fuse disconnects, etc. Sullair provides a wiring diagram for use by the installer.

WARNING

Lethal shock hazard inside.

Disconnect all power at source before opening or servicing starter or control panel.

1. Check incoming voltage. Be sure that the incoming voltage is the same voltage that the compressor was wired for.

2. Check starter and overload heater sizes (see electrical parts in Parts Manual).
3. Check all electrical connections for tightness.

4.7 MOTOR ROTATION CHECK

After the electrical installation has been done, it is necessary to check the direction of motor rotation.

With the control system in MANUAL MODE, pull out the **EMERGENCY STOP** button and press once, quickly and in succession, the **(START)** “**I**” and **(STOP)** “**O**” pads. This action will bump start the motor for a very short time. When looking at the motor rear end, the driveline should be rotating in the direction indicated by the “Direction of Rotation” decal located on the top of the compressor/motor adapter piece. If the reversed rotation is noted, disconnect the power to the starter and exchange any two of the three power input leads, then re-check rotation. A “Direction of Rotation” decal is located on the top of the compressor/motor adapter piece.

Section 5 OPERATION

5.1 GENERAL

While Sullair has built into this compressor a comprehensive array of controls and indicators to assure you that it is operating properly, you will want to recognize and interpret the reading which

will call for service or indicate the beginning of a malfunction. Before starting your Sullair compressor, read this section thoroughly and familiarize yourself with the controls and indicators - their purpose, location and use.

5.2 PURPOSE OF CONTROLS

CONTROL OR INDICATION	PURPOSE
FLUID LEVEL SIGHT GLASS	Monitors fluid level in the sump. Proper level should fill the sight glass. Check level when the compressor is shut down. DO NOT OVERFILL.
SEPARATOR RETURN LINE SIGHT GLASS	Used to indicate fluid flow in the return lines. When the compressor is running at full load, fluid flow should be visible in this sight glass. There may be little or no flow when the compressor is running unloaded, but a sluggish flow at full load indicates a need to clean the return line strainer.
FLUID STOP VALVE	Cuts off flow of fluid to compressor unit at compressor shutdown and allows flow of fluid to the unit on startup.
DISCHARGE CHECK VALVE	Cuts off the reverse flow of air/fluid mixture through compressor discharge system at compressor shutdown.
THERMAL VALVE	Regulates flow of fluid to and around the cooler. Designed to maintain a minimum operating temperature of 220°F (104°C). Also used for fast warm-up on startup.
MINIMUM PRESSURE/CHECK VALVE	Maintains minimum of 160 psig (11 bar) in the compressor sump. Valve piston restricts receiver air discharge from receiver/sump when pressure falls to 160 psig (11bar). Prevents line pressure backflow into the sump during unload conditions and after shutdown.
PRESSURE RELIEF VALVE (SUMP)	Opens sump pressure to the atmosphere should pressure inside the sump becomes too high (400 psig [27.6 bar]). Operation of this valve indicates that there is a mechanical or electrical malfunction.
PRESSURE RELIEF VALVE (INTER-STAGE)	Opens interstage of compressor to atmosphere should the pressure become too high (200 psig [13.8 bar]). Operation of this valve indicates unit pressurization during shutdown. Causes may be plugged control lines, faulty discharge check valve, or faulty fluid stop valve.
INLET POPPET VALVE	Regulates the amount of air allowed to enter the air inlet valve. This regulation is determined by the amount of air being used at the service line.
PRESSURE REGULATOR (INLET POPPET VALVE)	Opens a pressure line between the sump and inlet poppet valve allowing to regulate air delivery according to the air demand.
PRESSURE REGULATOR (UNLOAD)	Opens a pressure line between the sump and the inlet poppet valve to regulate the unload pressure.

Section 5 OPERATION

5.2 PURPOSE OF CONTROLS (CONTINUED)

CONTROL OR INDICATION	PURPOSE
BLOWDOWN SOLENOID VALVE	Opens when a demand for an unload/shutdown condition exists. When valve is opened, it will supply air to the blow-down valve.
BLOWDOWN VALVE	Vents sump pressure to the atmosphere during unload/shut-down conditions.
EMERGENCY STOP SWITCH	Pushing in this switch, found adjacent to the Supervisor, cuts all AC outputs from the latter and de-energizes the starter. A fault message (E STOP) is displayed by the Supervisor until the button is pulled out and the "O" pad is depressed.

5.3 PARAMETER SETUP

Pressing the program key "PRG" enters parameter display and edit mode. To move to the next parameter press the program key. To increment a parameter press the up arrow key "▲" or logo key "⊕". The logo key will increment by 10. To decrement the value press the down arrow key "▼".

The parameters are displayed in the following order:

- **Unload pressure** - The pressure where the machine is unloaded. For example if this parameter is set to 360 psi (24.8 bar) the machine will unload when the line pressure is above 360 psi (24.8 bar).

UNLOAD
360 PSI

- **Load differential** - The pressure differential below the unload pressure where the machine is loaded. For example if the unload pressure is set to 360 psi (24.8 bar) and the load differential is set to 10 psid (0.7 bar), the machine will load when the line pressure goes below 350 psi (34.1 bar).

LOAD
10 PSI

- **P1 Max** - Maximum sump pressure. An alarm and shut down will occur when the sump pressure rises above this pressure.

P1 MAX
370 PSI

- **Wye to delta transition timer** - For full voltage starters this parameter is set to 0.

WYE DELT
10 SEC

- **Restart time** - Time to wait after power-up before starting machine. This parameter is used to keep several machines from starting at the same time after power up, or to delay start until other equipment is started. If disabled the machine will not automatically start after power up.

RST TIME
10 SEC

- **Unload Stop Timer** - If the machine is running in AUTO mode, this parameter specifies the amount of time that the machine will run unloaded before shutting off. If the time is set less than 15 minutes (for example 5), there may be times when the machine will run unloaded for more than 5 minutes. This is because there is another timer that keeps the machine from being started more than four times an hour.

UNLD TIM
15 MIN

- **Language select** - English, German, Spanish, Italian and French may be selected for display language.

LANGUAGE
ENGLISH

Section 5 OPERATION

- **Units** - English or metric units may be selected.

UNITS
ENGLISH

- **Communications ID #** - This is the network address of a machine. If there is more than one machine connected to the network, each machine must have a unique number

COM ID #
1

- **Communications baud rate** - This should always be selected to 9600 baud for all sequencing modes. It may be lower for slave or monitoring modes.

BAUDRATE
9600

- **Sequence method** - This parameter sets the method used for sequencing. The choices are DISABLED, REMOTE, SLAVE, HOURS, COM ID#. See the Sequencing & Protocol Manual (P/N 02250057-696) for details about these modes.

SEQUENCE
HOURS

- **Drain interval** - The time between actuation of the drain valve.

DRN INTV
10 MIN

- **Drain time** - The amount of time that the drain valve is actuated.

DRN TIM
1 SEC

- **Last Communication Number** - Used only for sequencing, see Sequencing & Protocol Manual for details.

LAST COM
3

- **Lowest Allowable Pressure** - Used only for sequencing, see Sequencing & Protocol Manual for details.

LOWEST
90 PSI

- **Recovery Time** - Used only for sequencing, see Sequencing & Protocol Manual for details.

RECOVER
10 SEC

- **Rotate Time** - Used only for sequencing, see Sequencing & Protocol Manual for details.

ROTATE
50

- **Machine Capacity** - Used only for sequencing, see Sequencing & Protocol Manual for details.

CAPACITY
100

- **Sequence Hours** - Used only for sequencing, see Sequencing & Protocol Manual for details.

SEQ HRS
1000

5.4 OPERATING THE COMPRESSOR

Before operating the compressor the operating parameters must be setup. See the previous section on operating parameter setup.

MANUAL OPERATION MODE

In this mode the compressor will run indefinitely, as long as temperatures and pressure remain within the valid operating ranges, and the motor overload or emergency stop contacts are not tripped.

Pressing the "I" will turn on the compressor and put it in manual mode. If the compressor is already running, but in automatic mode, pressing "I" will switch operation to manual. Pressing "I" while already running in manual mode will cause the Supervisor to turn off the common fault relay, if engaged, and clear any maintenance indicators.



To stop the compressor, press "O". If the compressor is already off when "O" is pressed, the



Section 5 OPERATION

common fault relay will be turned off, if engaged, and it will try to clear the alarm and maintenance indicators. Regardless of what the compressor is doing, pressing “” puts the Supervisor in manual stop mode.

AUTOMATIC OPERATION MODE

In this mode the compressor will start if line pressure (P2) is less than the **LOAD** parameter. It will stop if the compressor runs unloaded for the number of minutes indicated by the **UNLD TIM** parameter. To put the compressor in automatic mode press “”. If P2 is already less than **LOAD** the compressor will start immediately, otherwise the system status will indicate **STANDBY** and the LED marked **AUTO** will flash.

If the compressor is already running, but in continuous mode, pressing “” will switch operation to automatic. Pressing “” while already running in automatic mode will cause the Supervisor to turn off the common fault relay, if engaged, and clear any maintenance indicators.

In automatic mode the compressor can be stopped manually by pressing “”. Stopping the compressor using “” will put the Supervisor in manual stop mode.

Regardless of whether in “automatic” or “manual” mode, control of the load solenoid will be based on the parameters **UNLD** and **LOAD**. This operation is as follows:

- P2 > UNLD** → load solenoid turned off
- P2 < LOAD** → load solenoid turned on

5.5 SUPERVISOR II OUTPUT RELAYS

RELAY	OPERATION
RUN RELAY (K1)	Contact closure energizes the compressor starter.
*-DELTA (K2)	A timed contact used to provide wye-delta transition time.
UNLOAD/LOAD (K3)	Controls ON LOAD/OFF LOAD operator of the load control solenoid valve.
COMMON FAULT (K4)	May be used to provide remote indication of any pre-alarm, maintenance or fault shutdown condition.
DRAIN VALVE (K5)	Controls a solenoid valve to provide automatic condensate removal.
FULL LOAD/MODULATE (K6)	Used with sequencing feature.

NOTE: All output relays will handle 8 amperes at 120/240 VAC.

POWER FAILURE RESTART

If the restart timer (RST TIME parameter) is disabled the compressor will not try to start after a power up. If this time is set to a value the machine will go into standby after power up. When the line pressure drops below the load setpoint, the restart timer will start timing. When the timer expires the machine will start.

SEQUENCING MODES

The following is a brief description of sequencing modes, for details see the Supervisor Sequencing & Protocol Manual (P/N 02250139-197).

- **DISABLED** - Responds to status and parameter change messages via the RS485 network but will not respond to start, stop, load or unload messages.
- **REMOTE** - Responds to status and parameter change messages but will not respond to start, stop, load or unload messages. The remote inputs and outputs are enabled (start/stop, load/unload, master/local).
- **SLAVE** - Will respond to all messages, but will not start or load unless commanded to do so by a message. This mode is used to control the machine from a master computer.
- **HOURS** - Sends status message about once a second, starts, loads and unloads machines based on sequencing hours.
- **COM ID #** - Sends status message about once a second, starts, loads and unloads machines based on machine Com ID#.

Section 5 OPERATION

5.6 INITIAL START-UP PROCEDURE



The following procedure should be used to make the initial start-up of the compressor:

1. Read the preceding pages of this manual thoroughly.
2. Be sure that all preparations and checks described in the Installation Section have been made.
3. Crack open the shut off valve to the service line.
4. Start the compressor by pressing the “” (START) pad.
5. Check for possible leaks in piping.
6. Slowly close the shut-off valve and check that the maximum pressure (P2) and pressure differential (P2) are correctly programmed.
7. Observe the operating temperature. If the oper-

ating temperature exceeds 235°F (113°C), the cooling system or installation environment should be checked.

8. Observe return line sight glasses and maintenance indicators.
9. Open shut-off valve to service line.
10. Reinspect the compressor for temperature and leaks the following day.

5.7 SUBSEQUENT START-UP PROCEDURE

On subsequent start-ups, check that the proper level is visible in the fluid level sight glass and simply press “” for manual or “” for automatic operation. When the compressor is running, observe the various parameter displays.

5.8 SHUTDOWN PROCEDURE

To shut the compressor down, push “” pad.

NOTES

Section 6 MAINTENANCE

6.1 MAINTENANCE INTRODUCTION

The Supervisor II monitors the status of the air filter, fluid filter, and separator elements. When maintenance to these devices is required, the Supervisor II will display the appropriate maintenance message and flash the location LED on the graphics map as a visual reminder.



DO NOT remove caps, plugs, and/or other components when compressor is running or pressurized.

Stop compressor and relieve all internal pressure before doing so.

6.2 DAILY OPERATION

Following a routine start, observe the various Supervisor II displays to check that normal readings are being made - previous records are very helpful in determining the normalcy of the measurements. These observations should be made during all expected modes of operation (i.e. full load, no-load, different line pressures, cooling water temperatures, etc.).

During the initial start-up or servicing of the package, fluid may have to be added to the sump vessel to restore an adequate level. Frequent fluid additions to maintain said level would be indicative of excessive fluid consumption, and should be investigated - see the Troubleshooting Section of this manual for probable cause and remedy.

6.3 MAINTENANCE AFTER INITIAL 50 HOURS OF OPERATION

After the initial 50 hours of operation, a few maintenance requirements are needed to rid the system of any foreign materials which may have accumulated during compressor assembly. Perform the following maintenance operations to prevent unnecessary problems.

1. Clean the return line strainers.
2. Clean the return line orifices.
3. Change the fluid filter elements.
4. Clean the control line filters.

6.4 MAINTENANCE AS REQUIRED BY LUBRICATION GUIDE (SECTION 3)

1. Drain the sump and change the compressor fluid.
2. Replace the main fluid filter element.
3. Clean the return line strainers and orifices.
4. Clean or replace the control line filter element.

6.5 FLUID CHANGE

Standard models are filled with Sullube. Sullube

should be changed under the following conditions, whichever occur first:

1. Every 1800 hours.
2. Once a year.
3. As indicated by fluid analysis.

A fluid sample at every 1000 hours is recommended. For a free Sullube analysis, send fluid to:

Dow Chemical
Lubricant Technology Center
Building B-1605
Freeport, TX 77541

To facilitate this, a sample bottle is included with the compressor.

6.6 SEPARATOR MAINTENANCE

Replace the separator elements when the separator maintenance message is displayed or after one (1) year, whichever comes first. The separator elements must be replaced. **DO NOT** clean the separator elements.

6.7 PARTS REPLACEMENT AND ADJUSTMENT PROCEDURES

FLUID FILTER MAINTENANCE

Refer to Figure 6-1. The fluid filter (P/N 02250111-592) is located schematically between the thermal valve on the sump and the oil stop valve on the compressor-mounting bracket. When servicing this filter, shut the compressor down, make sure all pressure has been released, then follow the instructions below. For element replacement order kit number 250031-850.



To minimize the possibility of filter element rupture, it is important that **ONLY** replacement elements identified with the Sullair name, logo and appropriate part numbers be used, and that substitute elements **NOT** be used, due to the fact that such filters may have inadequate or questionable working pressure ratings.

1. Unthread the filter canister from the head. A hex nut is supplied on the bottom of the canister along with the bottom portion of the canister has a rough textured surface. Either can be used to assist in removal of the canister.
2. Pull the canister away from the filter head. The filter elements will be attached to the filter head.
3. Separate the element from the filter head.
4. Remove the canister seal.
5. Thoroughly clean the filter head and canister in solvent.

Section 6 MAINTENANCE

Figure 6-1 Main Filter (P/N 02250111-592)

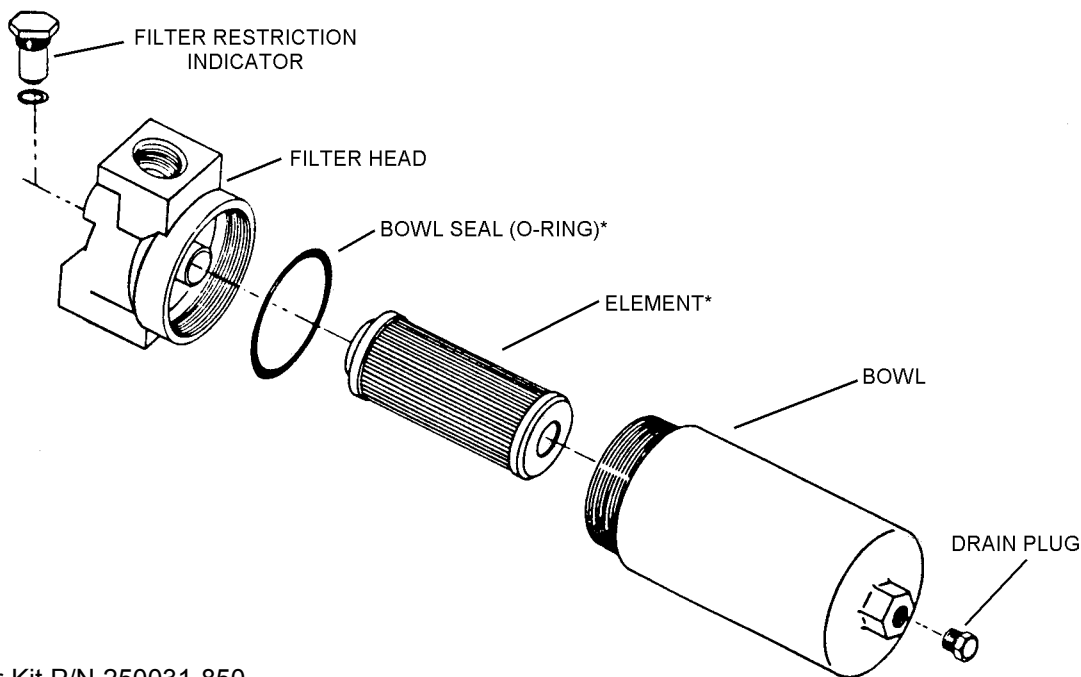

*Repair Kit P/N 250031-850

6. Lubricate the new seals with the same type of fluid used in the compressor and position each seal in its appropriate place.
7. Carefully push the element into position under the housing/head.

8. Replace the canister by threading back onto the filter head.

AIR FILTER MAINTENANCE

Refer to Figure 6-2. Air filter maintenance should be performed when the air filter maintenance mes-

Figure 6-2 Air Filter Replacement (P/N 048456)

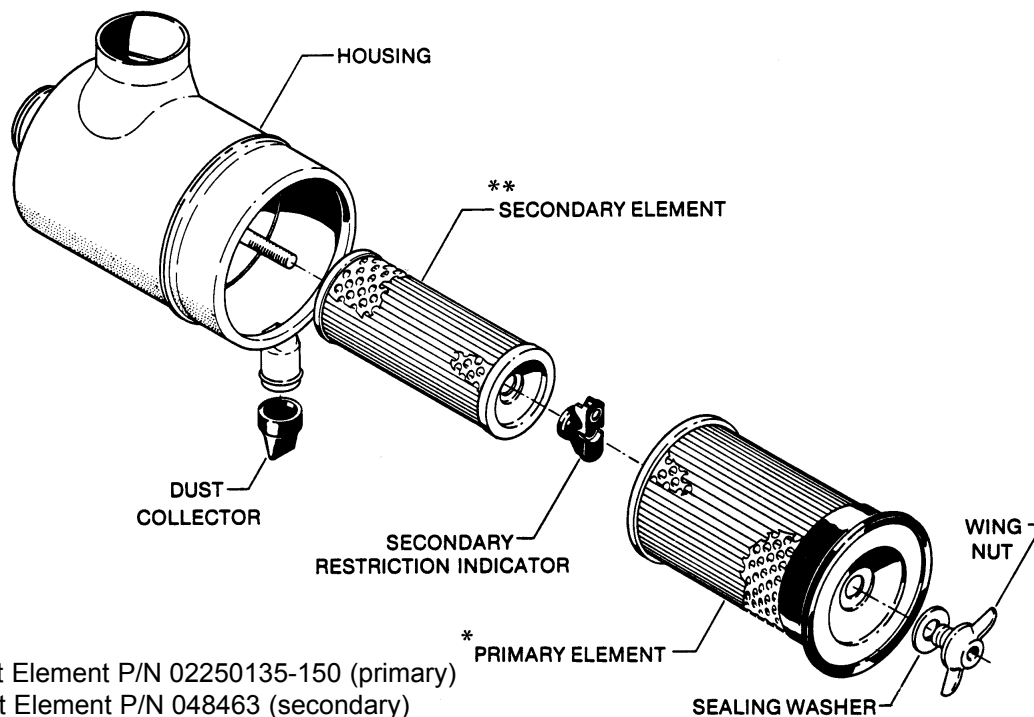

*Replacement Element P/N 02250135-150 (primary)

**Replacement Element P/N 048463 (secondary)

Section 6 MAINTENANCE

sage is displayed. The air filter is equipped with a primary and a secondary element. As previously stated, the Supervisor II will alert you as to when the primary element maintenance is necessary. When removing the primary element, always check the secondary element for visible dirt, grease/oil, or damage. The secondary element must be changed after every sixth primary element inspection. **DO NOT** clean the secondary element.

AIR FILTER ELEMENT REMOVAL

1. Clean exterior of air filter housing.
2. Remove the cover/element assembly by loosening the wing nut securing it.
3. Pull the cover/element assembly out of the housing.
4. On the inside of the element, you will notice a lock ring, which fastens the cover to the element. Remove the lock ring and pull the cover and element apart.
5. Clean the interior of the housing by using a damp cloth. **DO NOT** blow dirt with compressed air.
6. Inspect the secondary element and replace if necessary. This element is **NOT** cleanable.
7. To remove the secondary element, unscrew the secondary restriction indicator from the threaded rod running through the element. Pull the element out of the housing.
8. Install the new secondary element and replace the restriction indicator.
9. With the secondary element in place, clean or replace the primary element. Cleaning instructions follow.

ELEMENT INSPECTION

1. Place a bright light inside the element to inspect for damage or leak holes. Concentrated light will shine through the element and disclose any holes.
2. Inspect all gaskets and gasket contact surfaces of the housing. Should faulty gaskets be evident, correct the condition immediately.
3. If the clean element is to be stored for later use, it must be stored in a clean container.
4. After the element has been installed, inspect and tighten all air inlet connections prior to resuming operation.

PRIMARY ELEMENT REPLACEMENT

1. Place the element in position on the cover and replace the locking to secure the cover and element.

Figure 6-3 Separator Element Replacement

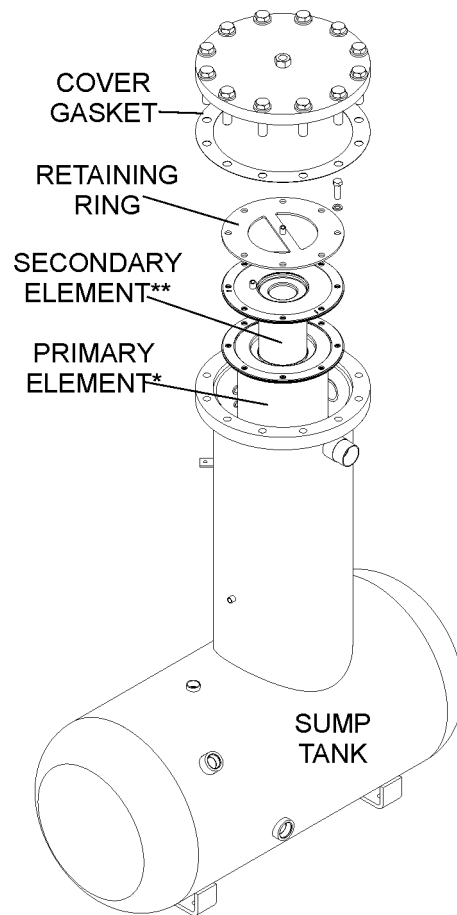

*Primary Replacement Element/Gasket Kit P/N 02250122-833

**Secondary Replacement Element P/N 02250122-832

***Cover gasket (Tank Lid) P/N 02250121-188 (**NOTE:** this gasket is included with kit no. 02250122-833 listed above).

2. Install the cover/element assembly and replace the wing nut. Tighten the wing nut so to seat the element gasket fully.

SEPARATOR MAINTENANCE

Refer to Figure 6-3. When the need for a separator element replacement is indicated by the Supervisor II, use the following procedure for separator replacement.

1. Remove the air receiver/separator tank lid by removing the twelve (12) hex head capscrews.

NOTE

To assist with the removal of the tank lid, Sullair has provided a 1"-8 nut to the top lid so it can be removed by a 1"-8 eye bolt (which is available from Sullair) or a similar type of lifting device.

Section 6 MAINTENANCE

- Remove the 3/4"-10 jam nut and sealing hex nut from the 3/4"-10 separator hold down rod.
- Remove the round separator cover plate from the top of the separator element.
- Remove the old separator element and discard.
- Scrape the old gasket material from the tank lid mounting surface and the flanges mounting surface on the tank. Be sure to keep all scrapings from falling back inside of the tank.
- Before installing the new separator elements, make sure to lubricate both sealing gaskets on the element with a lubricating compound (i.e. Silglyde). Now install the new separator elements and retaining ring. Torque the capscrews to 85 to 90 ft.-lbs. (115 to 122 Nm). **DO NOT** over-tighten, as damage to the separator element can result.
- Next, install the tank flange gasket that is provided. Before installing, lubricate both sides of the gasket (i.e. Silglyde). Reinstall the tank lid. Install the capscrews finger tight, then gradually tighten in a crisscross pattern in 4 to 5 steps. Always tighten the capscrews alternately at

opposite sides of the cover. Lube torque capscrews to 200 ft.-lbs. (271Nm).

- Clean or replace fluid return line strainer.
- Clean the fluid return line orifice installed in the side of the compressor unit air end.
- After assembly is complete, check for continuity between the separator flange and the lid and tank flange with an ohmmeter.

OIL RETURN/SIGHT GLASS MAINTENANCE

Refer to Figure 6-4. The oil return/sight glass sub-assembly is attached to the separator tank lid. Oil return/sight glass maintenance should be performed on a routine basis parallel to that of the fluid filter, or as indicated in the Troubleshooting Sections (both Supervisor II and Maintenance) of this manual. The maintenance on an oil return/sight glass is mainly concerned with the condition of the filter assembly. Order filter assembly no. 02250117-782, and use the following instructions as a guide.

NOTE

Always performing maintenance on both oil return/sight glasses at the same time.

- Disconnect the tubes at the tops of the sight glass assemblies.
- Unscrew male connector (for left-side glass), or the straight thread tube connector (for right-side glass) from sight glass/orifice blocks.
- Remove used filter assembly, and replace with new assembly.
- Coat/lubricate the o-rings with silicone grease.
- Reattach the connectors to the sight glass/orifice blocks.

DIFFERENTIAL PRESSURE REGULATOR ADJUSTMENT

Refer to Figure 6-5 and 6-6. The differential pressure regulators are adjusted by loosening the adjusting screw on the end of the cone-shaped cover of the pressure regulator. When the jam nut is loose, turn the adjusting screw clockwise to increase or counterclockwise to decrease the setting.

The reference pressure regulator should be set to maintain a 60 psig (4.14 bar) downstream pressure to the inlet poppet valve. The unload pressure regulator should be set at 150 psig (10.3 bar) to control the compressor package during unload only. The inlet poppet valve control pressure regulator should be set to control the systems modulation to

Figure 6-4 Oil Return/Sight Glass

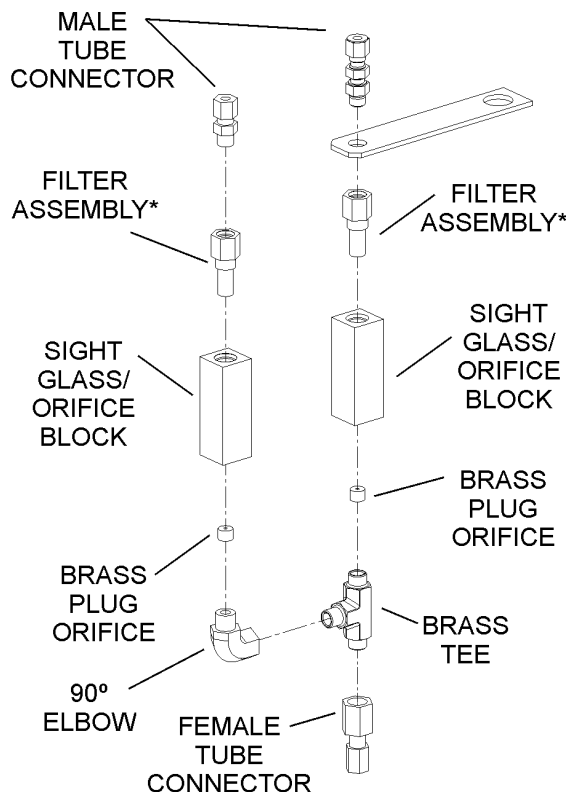

*Replacement Filter Assembly P/N 02250117-782

Figure 6-5 Pressure Regulator Adjustments

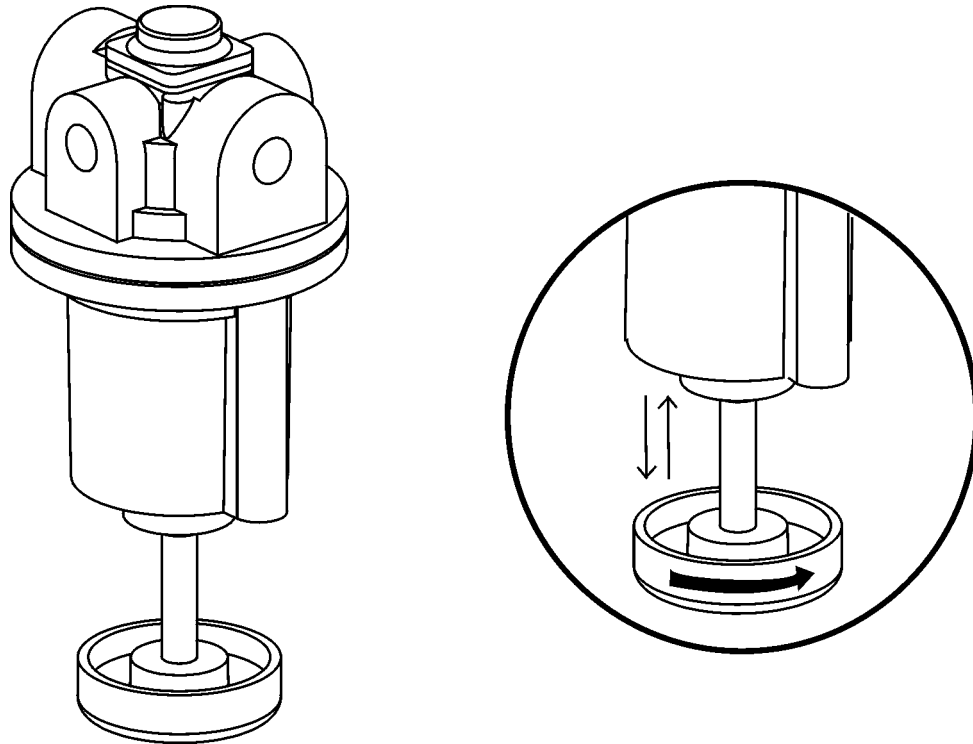
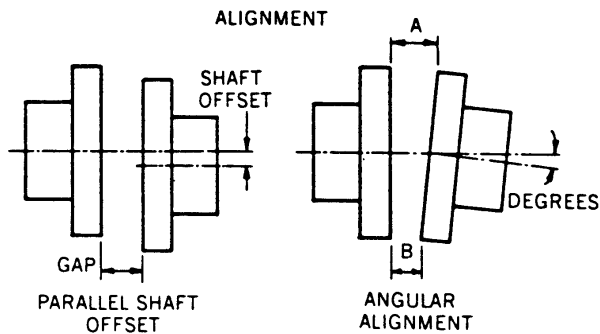

Figure 6-6 Drive Coupling Alignment



the service line desired pressure.

DRIVE COUPLING INSTALLATION AND ALIGNMENT

WARNING

Applies to base-mounted compressors and drives only. Units mounted through common housing are self-aligning. If alignment is suspect, use the following procedure.

Refer to Figures 6-6, 6-7 and 6-8. For coupling installation and alignment, the tools required will be one set of standard allen wrenches and a dial indicator. If a dial indicator is not available, an alternate method of checking the alignment may be used as a secondary or less desirable technique. This

Table 6-1 Installation Data

Parallel Offset inches/mm	Coupling Gap + .03 in./ .762mm	Max. Operating Misalignment Angular	
		Degrees	inches/ mm (I)
.008/ .02	1.38/ 35.0mm	.025	.005/ 127mm

(I) Angular misalignment in inches equals maximum A minus minimum B as shown in Figure 6-6. **DO NOT** exceed values in Table 6-1 above.

method of checking is done by careful use of a square or metal straight edge feeler gauge and a set of inside calipers (see Figure 6-8). Those specifications in Table 6-1 Installation Data which are designated in inches are provided for this method.

Figure 6-7 Drive Coupling

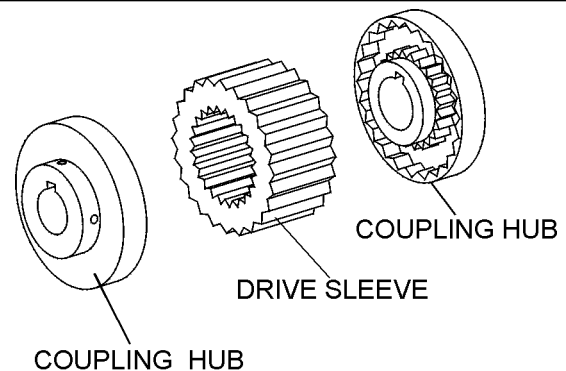

Section 6 MAINTENANCE

Figure 6-8 Parallel/Angular Alignment

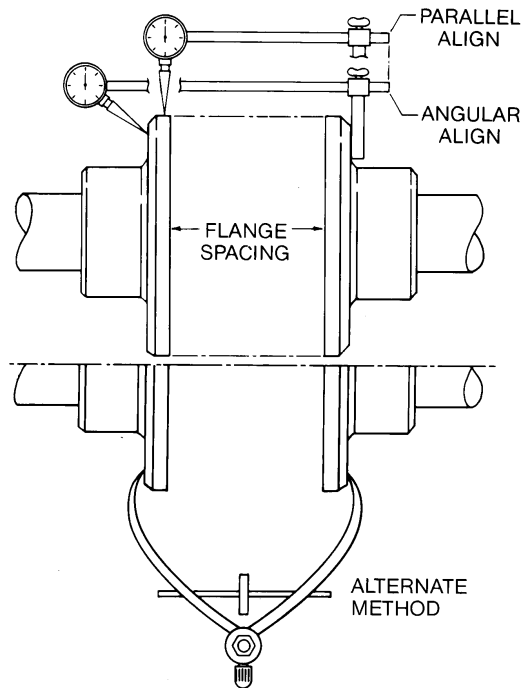

For installation and maintenance of the drive coupling, follow the steps explained below.

WARNING

Disconnect all power at source, before attempting maintenance or adjustments.

STEP 1 - MOUNT HUBS

After, carefully inspecting the hub bores and the shafts for dirt and burrs, mount the motor hub and the compressor hub on their respective shafts. It is also necessary to check for a proper key fit. Place the keys in position being sure that the end of the key is flush with the end of the shaft. Secure the compressor hub on the shaft with setscrews. Place the element between the hubs and push the motor

hub to engage the element. After engaging the element, set the motor hub for the proper gap as specified in [Table 6-1 Installation Data](#), and secure the motor hub with a setscrew. When the hub gap is properly set, you will be able to move the element in a slight back and forth motion (unless the coupling is extremely out of alignment).

STEP 2 - ANGULAR ALIGNMENT

Clean fluid and dirt from the hubs in preparation for angular alignment. Position the dial indicator on the hubs as shown in Figure 6-8. Rotate both hubs equally to check alignment.

STEP 3 - PARALLEL OFFSET ALIGNMENT

Reposition the dial indicator as shown in Figure 6-8. Rotate both hubs equally to check for misalignment. Parallel offset alignment is equal to 1/2 the difference in indicator readings of 180° apart or the gap between the hub and straight edge when the alternate method is used. Vertical parallel offset is corrected by the addition or removal of equal amounts of shims under the motor feet while horizontal parallel offset is corrected by sliding the motor sideways.

Angular alignment is indicated by the difference in indicator readings or by the difference in caliper measurements (X) ($A - B = X$). Vertical angular alignment is achieved by placing shims under the front or rear motor feet while horizontal angular alignment is achieved by sliding the motor sideways.

Section 7 TROUBLESHOOTING

7.1 TROUBLESHOOTING

The information contained in the Troubleshooting chart is based upon both actual applied situations and extensive testing at the factory. It contains symptoms and usual causes for the described problems. However, **DO NOT** assume that these are the only problems that may occur. All available data concerning the trouble should be systematically analyzed before undertaking any repair or component replacement procedures.

A detailed visual inspection is worth performing for almost any problems which may prevent unnece-

sary damage to the compressor. Always remember to:

- a. Check for loose wiring.
- b. Check for damaged piping.
- c. Check for parts damaged by heat or an electrical short circuit, usually apparent by discoloration or a burnt odor.

Should your problem persist after making the recommended check, consult your nearest Sullair representative or the Sullair Corporation factory.

7.2 TROUBLESHOOTING GUIDE

SYMPTOM	PROBABLE CAUSE	REMEDY
COMPRESSOR WILL NOT START	Main Disconnect Switch Open	Close switch.
	Line Fuse Blown	Replace fuse.
	Control Transformer Fuse Blown	Replace fuse.
	Motor Starter Overloads Tripped	Reset. Should trouble persist, check whether motor starter contacts are functioning properly.
	Low Incoming Line Voltage	Check voltage. Should voltage check low, consult power company.
COMPRESSOR SHUTS DOWN	Loss of Control Voltage	Reset. If trouble persists, check that line pressure does not exceed maximum operating pressure of the compressor (specified on nameplate).
	Low Incoming Voltage	Consult power company.
	Excessive Operating Pressure	Separator requires maintenance; check dP1 under full load conditions. Defective blowdown solenoid valve; repair if defective (kit available). Defective blowdown valve; blowdown valve should exhaust sump pressure to the atmosphere when maximum operating pressure is reached. Repair or replace as necessary (kit available).
	P1 High Pressure Shutdown Parameter is Adjusted Too Low	Readjust MAX P1 setpoint appropriately.
	High Discharge Temperature	Cooling water temperature too high; increase water flow (water-cooled). Cooling water flow insufficient; check water lines and valves. (water-cooled).

Section 7 TROUBLESHOOTING

7.2 TROUBLESHOOTING GUIDE(CONTINUED)

SYMPTOM	PROBABLE CAUSE	REMEDY
COMPRESSOR SHUTS DOWN (CONTINUED)	High Discharge Temperature (Cont.)	Cooler plugged; clean tubes. If plugging persists, install water conditioner. (water-cooled).
		Low fluid level; add fluid.
		Clogged filter; change the fluid filter element if maintenance indicator shows red, and/or dP2 on controller indicates high dP.
		Thermal valve not functioning properly; replace element.
		Cooling air flow restricted; clean cooler and check for proper ventilation (air-cooled).
		Ambient temperature too high; provide sufficient ventilation (air-cooled).
	RTD probe out of calibration, or bad RTD. Replace if necessary.	
	Low Fluid Pressure	Clogged filter; replace fluid filter element
	Low Water Pressure	Check water lines and valves (water-cooled).
COMPRESSOR WILL NOT BUILD UP FULL DISCHARGE PRESSURE	Air Demand is Too Great	Check service lines for leaks or open valves.
	Dirty Air Filter	Check the filter indicator and change or clean element if required.
	Defective Pilot Pressure Regulator	Check diaphragm and replace if necessary (kit available).
	Defective Minimum Pressure Valve	Check that the piston is moving freely.
	Defective Control Inlet Solenoid Valve	Repair or replace.
LINE PRESSURE RISES ABOVE P2 PRESSURE	Leak in Control System Causing Loss of Pressure Signals	Check for leaks.
	Defective Blowdown Solenoid Valve	Repair or replace if necessary (kit available).
	Defective Blowdown Valve	Check that sump pressure is exhausted to the atmosphere when the unload pressure setting on Supervisor is met, or repair or replace if necessary (kit available).
EXCESSIVE COMPRESSOR LUBRICANT CONSUMPTION	Clogged Return Line or Orifice	Clean strainer (screen and o-ring replacement kit available).
		Clean orifice.
	Separator Elements Damaged or Not Functioning Properly	Change separator elements.

Section 7 TROUBLESHOOTING

7.2 TROUBLESHOOTING GUIDE (CONTINUED)

SYMPTOM	PROBABLE CAUSE	REMEDY
EXCESSIVE COMPRESSOR-LUBRICANT CONSUMPTION (CONTINUED)	Leak in the Lubrication System	Check all pipes, connections and components.
	Excessive Fluid Foaming	Drain fluid and change.
	Fluid Level Too High	Drain excess fluid.
SUMP PRESSURE RELIEF VALVE OPENS REPEATEDLY	High Pressure Shutdown Parameter is Out of Adjustment	Readjust below pressure relief valve setting.
	Defective Pressure Relief Valve	Replace pressure relief valve.
	Defective Pressure Transducer	Recalibrate or replace.
	Defective Minimum Pressure Valve	Repair or replace.
	High Separator Differential (dP1)	Replace separator elements.
	Defective Blowdown Valve	Repair or replace (kit available).
	Defective Blowdown Solenoid Valve	Repair or replace (kit available).
INTERSTAGE PRESSURE RELIEF VALVE OPENS REPEATEDLY	Plugged or Frozen Control Lines	Replace or thaw as needed.
	Defective Discharge Check Valve	Repair or replace (kit available).
	Defective Oil Stop Valve	Repair or replace (kit available).
	Defective Pressure Relief Valve	Replace pressure relief valve.

NOTES

Section 8

ILLUSTRATIONS AND PARTS LIST

8.1 PROCEDURE FOR ORDERING PARTS

Parts should be ordered from the nearest Sullair Representative or the Representative from whom the compressor was purchased. If for any reason parts cannot be obtained in this manner, contact the factory directly at the addresses, phone or fax numbers below. When ordering parts always indicate the Serial Number of the compressor. This can be obtained from the Bill of Lading for the compressor or from the Serial Number Plate located on the compressor.

SULLAIR ASIA, LTD.
 Sullair Road, No. 1
 Chiwan, Shekou
 Shenzhen, Guangdong PRV.
 PRC POST CODE 518068
 Telephone: 755-6851686
 Fax: 755-6853473
www.sullair-asia.com

SULLAIR CORPORATION
 3700 East Michigan Boulevard
 Michigan City, Indiana 46360 U.S.A.
www.sullair.com
 Telephone: 1-800-SULLAIR (U.S.A. Only)
 or 1-219-879-5451
 Fax: (219) 874-1273

PARTS DEPARTMENT
 Fax: (219) 874-1835
www.sullair.com/parts.shtm

SERVICE DEPARTMENT
 Fax: (219) 874-1205
www.sullaircompressors.com

SULLAIR EUROPE, S.A.
 Zone Des Granges BP 82
 42602 Montbrison Cedex, France
 Telephone: 33-477968470
 Fax: 33-477968499
www.sullaireurope.com

8.2 SPARE PARTS LIST- LS20TS

DESCRIPTION	KIT NUMBER	QTY
Replacement element for primary with gasket (I)	02250122-833	2
Replacement element for secondary separator (I)	02250122-832	2
Replacement lid gasket (separator) (I)	02250121-188	1
Replacement element for inlet filter 048456 (primary) (I)	02250135-150	1
Replacement element for inlet filter 048456 (secondary) (I)	048463	1
Replacement element for fluid filter 02250111-592 (I)	250031-850	2
Replacement element for control line filter 02250058-442 (I)	02250058-441	1
Repair kit for fluid stop valve 250041-069	02250051-747	1
Repair kit for minimum pressure valve 250031-852	consult factory	1
Repair kit for thermal valve 02250139-130	02250139-865	1
Repair kit for inlet valve 02250045-626	02250112-531	1
Rebuild kit for inlet valve 02250045-626	02250112-532	1
Repair kit for inlet valve 022500140-758	02250112-531	1
Rebuild kit for inlet valve 022500140-758	02250112-532	1
Replacement element for filter assembly 02250117-782	02250117-782	1
Repair kit for blowdown valve 045116	047524	1
Repair kit for pressure regulator 02250139-030 (New design)	02250139-037	1
Repair kit for pressure regulator 048354 (Old design) (I)	048410	1
Repair kit for pressure regulator 048059 (I)	048409	1
Repair kit for pressure regulator 045099 (I)	048409	1
Repair kit for solenoid valve 407390 (I)	02250053-830	1
Replacement coil for solenoid valve 407390	250031-431	1

(Continued on page 46)

(I) Recommended spare parts (quantities are reference only).

(PLEASE NOTE: WHEN ORDERING PARTS, INDICATE SERIAL NUMBER OF COMPRESSOR)

Section 8

ILLUSTRATIONS AND PARTS LIST

8.2 SPARE PARTS LIST- LS20TS (CONTINUED)

DESCRIPTION	KIT NUMBER	QTY
Repair kit for solenoid valve 02250125-657 (I)	02250125-829	1
Replacement coil for solenoid valve 02250125-657	02250125-861	1
Repair kit for discharge check valve assembly 02250127-507	606208-001	1
Repair kit for shaft seal	001811A	1
Replacement drive-coupling element (300hp) (I)(II)	02250075-399	1
Replacement drive-coupling element (350-400hp) (I)(II)	250006-267	1
Sullube fluid (5-gal can)	250022-669	30-gal
Sullube fluid (55-gal drum) (I)	250022-670	30-gal

(I) Recommended spare parts.

(II) Due to custom motor requests, drive-coupling elements may vary. Consult factory for correct size/component.

PLEASE NOTE: WHEN ORDERING PARTS, INDICATE SERIAL NUMBER OF COMPRESSOR

NOTES

Section 8 ILLUSTRATIONS AND PARTS LIST

8.3 MOTOR, FRAME, COMPRESSOR AND PARTS- 300-450HP/ 224-336KW

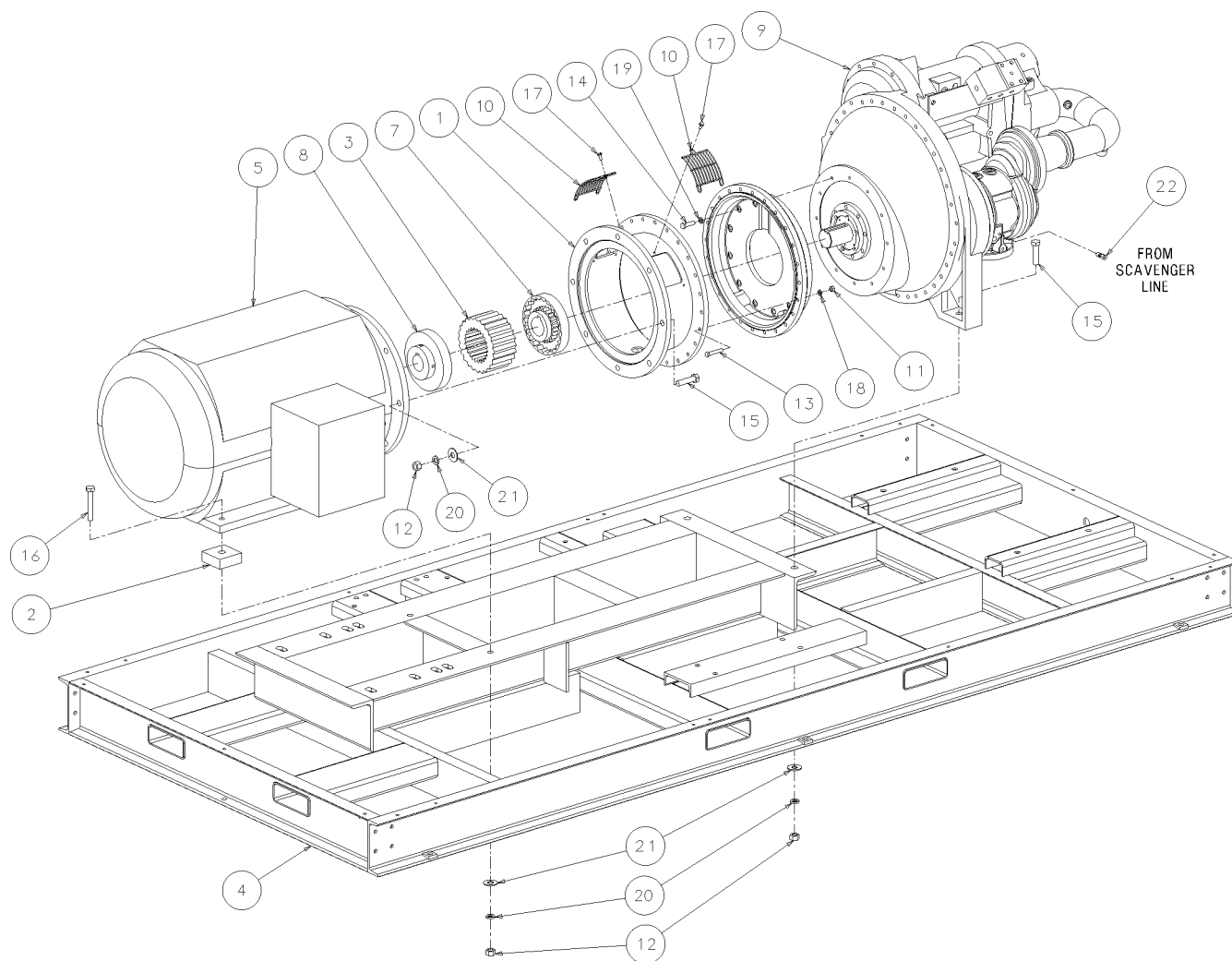

Section 8

ILLUSTRATIONS AND PARTS LIST

8.3 MOTOR, FRAME, COMPRESSOR AND PARTS- 300-450HP/ 224-336KW

<i>key number</i>	<i>description</i>	<i>part number</i>	<i>quantity</i>
1	adapter, mtr/compr ls20t (I)	-	1
2	bar, 1 1/2 x 4 x 4 hrs	022216	2
3	sleeve, 11h hytel (I)	-	1
4	frame, main LS20TS-300/600hp ac/wc	02250139-133	1
5	motor, 4ppe (I)	-	1
6	adapter (231811c) sae 1ddh20	026974	1
7	hub, coupling 2-3/4 - 11su	047141	1
8	hub, coupling 11 su 2-3/8"bore	049923	1
9	compr model, 20-12stretch unit (II)	-	1
10	grille, cplg guard compr/mtr	250040-319	2
11	nut, hex pltd 7/16-14	825207-385	24
12	nut, hex pltd 3/4-10	825212-665	12
13	capscr, hex gr5 7/16-14 x 2 1/2	829107-250	24
14	capscr, hex gr5 1/2-13 x 1 3/4	829108-175	12
15	capscr, hex gr5 3/4-10 x 3	829112-300	10
16	capscr, hex gr5 3/4-10 x 4 1/2	829112-450	2
17	screw, hex ser washer 5/16-18 x 3/4	829705-075	6
18	washer, spr lock reg pltd 7/16	837807-112	24
19	washer, spr lock reg pltd 1/2	837808-125	12
20	washer, spr lock reg pltd 3/4	837812-188	12
21	washer, pl-b reg pltd 3/4	838212-112	12
22	connector, tube-m 1/4 x 1/4 ss	876804-025	1

(I) Due to customized motor variances consult factory for part number.

(II) There is an exchange program whereby a remanufactured compressor unit can be obtained from Sullair distributors or the factory at less cost than the owner could repair the unit. For information regarding the unit exchange program, contact your nearest Sullair representative or the Sullair Corporation.

The shaft seal is not considered part of the compressor unit in regard to the two year warranty.
The normal Sullair parts warranty applies. For shaft seal repairs order repair kit no. 001811A.

PLEASE NOTE: WHEN ORDERING PARTS, INDICATE THE SERIAL NUMBER OF COMPRESSOR

Section 8 ILLUSTRATIONS AND PARTS LIST

8.4 AIR INLET SYSTEM

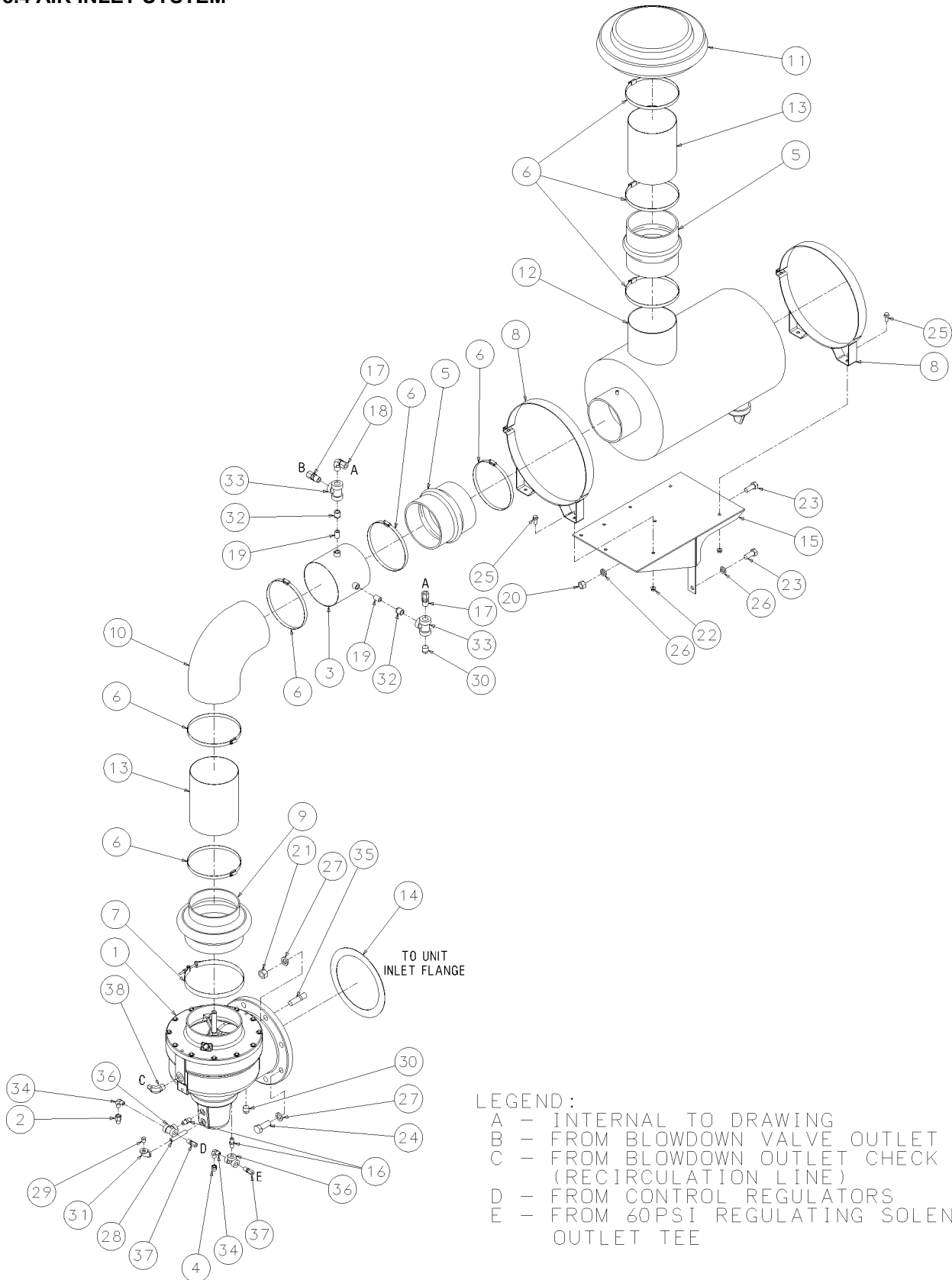

- LEGEND:
- A - INTERNAL TO DRAWING
 - B - FROM BLOWDOWN VALVE OUTLET
 - C - FROM BLOWDOWN OUTLET CHECK VALVE (RECIRCULATION LINE)
 - D - FROM CONTROL REGULATORS
 - E - FROM 60PSI REGULATING SOLENOID OUTLET TEE

02250135-237R01

Section 8 ILLUSTRATIONS AND PARTS LIST

8.4 AIR INLET SYSTEM

key number	description	part number	quantity
1	sub assembly, 8" inlet valve (I)	02250045-626	1
2	orifice, .040 1/4fnpt x 1/4mnpt	02250091-395	1
3	tube, 7" x 6.5" w/3/8" conn	02250120-368	1
4	orifice, cap .031" x 1/4" npt	02250132-934	1
5	hose, hump 7"	041917	2
6	clamp, hose 7"	041992	8
7	clamp, hose 8"	043598	1
8	band, mounting 16"	044248	2
9	adapter, red hump 8 x 7 x 6	045356	1
10	elbow, rubber 7 i.d. x 90 deg.	046078	1
11	cap, air inlet 7"	046307	1
12	filter, inlet optimalair 16"odx7"int (II)	048456	1
13	tube, alum air inlet 7"od x 9"lg	232591	2
14	gasket, asa flange 150# 8" (III)	240621-013	1
15	support, air inlet filter	250000-826	1
16	nipple, hx tbe 316s 1/4"	250018-760	2
17	connector, tube-m 1/2 x 1/2	810208-050	2
18	elbow, tube 90 deg m 1/2 x 1/2	810508-050	1
19	nipple, pipe-xs galv 3/8 x cl	823206-000	2
20	nut, hex pltd 5/8-11	825210-559	1
21	nut, hex pltd 3/4-10	825212-665	2
22	nut, hex f pltd 3/8-16	825306-347	4
23	capscr, hex gr5 5/8-11 x 1 1/2	829110-150	2
24	capscr, hex gr5 3/4-10 x 2	829112-200	6
25	screw, hex ser washer 3/8-16 x 1	829706-100	4
26	washer, spr lock reg pltd 5/8	837810-156	2
27	washer, spr lock reg pltd 3/4	837812-188	8
28	nipple, pipe-xs plt 1/4 x 3	866404-030	1

(Continued on page 53)

(I) For maintenance on air inlet valve assembly no. 02250045-626, order repair kit no. 02250112-531.
NOTE: See footnote (III) below.

(II) For maintenance on air filter no. 048456, order primary replacement element no. 02250135-150 and secondary replacement element no. 048463.

(III) When performing maintenance on inlet valve, if required, order gasket no. 240621-013.

PLEASE NOTE: WHEN ORDERING PARTS, INDICATE THE SERIAL NUMBER OF COMPRESSOR

Section 8 ILLUSTRATIONS AND PARTS LIST

8.4 AIR INLET SYSTEM

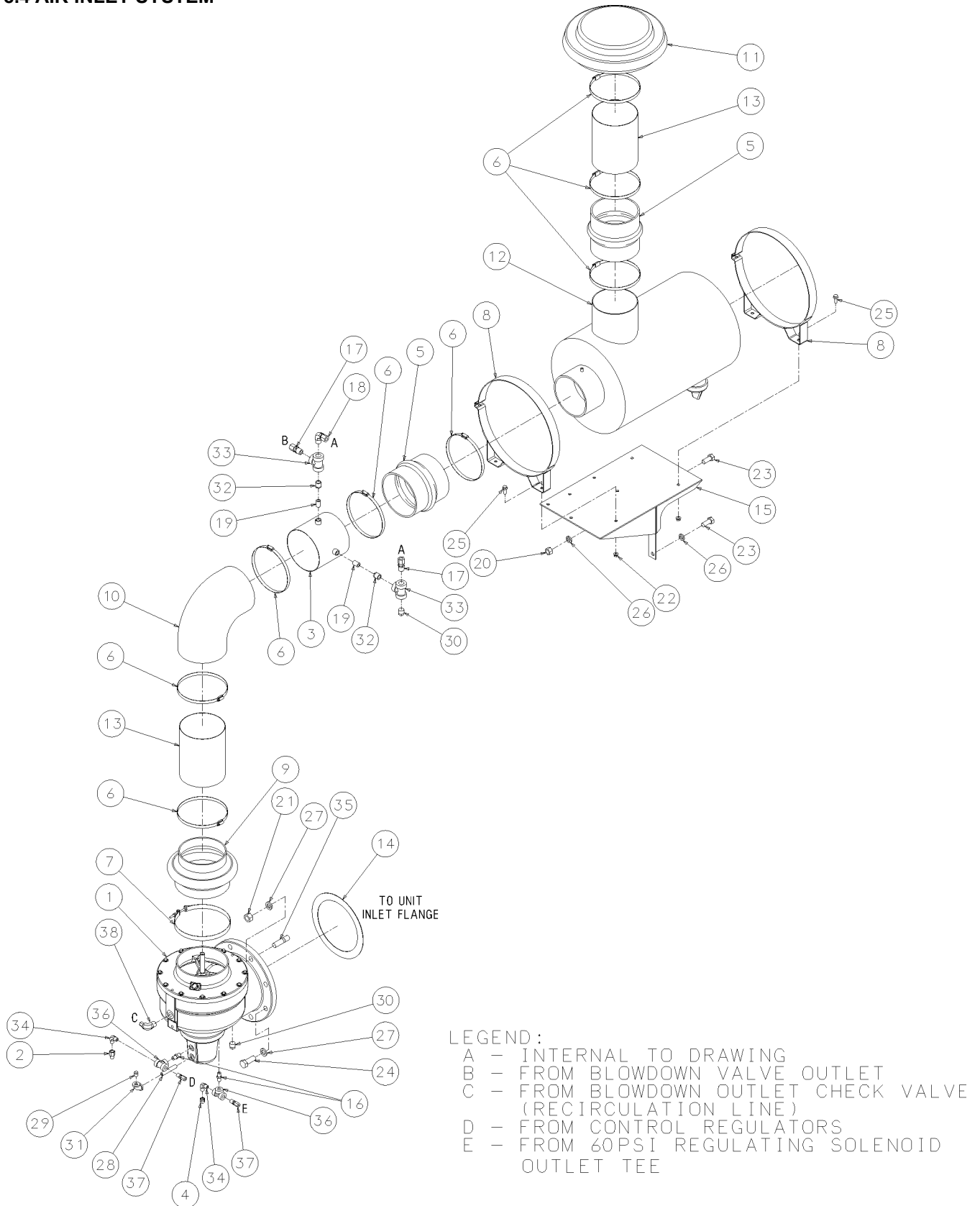

02250135-237R01

Section 8 ILLUSTRATIONS AND PARTS LIST

8.4 AIR INLET SYSTEM (CONTINUED)

<i>key</i> number	<i>description</i>	<i>part</i> number	<i>quantity</i>
29	plug, pipe 1/4" 3000# stl plt	866900-010	1
30	plug, pipe 1/2" 3000# stl plt	866900-020	3
31	elbow, pipe 90 deg 300# plt 1/4"	867030-010	1
32	bushing, red pltd 1/2 x 3/8	867102-015	2
33	tee, pipe pltd 1/2	868430-020	2
34	elbow, pipe-90m 1/4 x 1/4 ss	872204-025	2
35	stud, threaded 3/4-10 x 3 plt	873812-030	2
36	tee, pipe 300# 1/4 ss	876730-010	2
37	connector, tube-m 1/4 x 1/4 ss	876804-025	2
38	elbow, tube 90 deg m 1/4 x 1/2 ss	877004-050	1

PLEASE NOTE: WHEN ORDERING PARTS, INDICATE THE SERIAL NUMBER OF COMPRESSOR

Section 8 ILLUSTRATIONS AND PARTS LIST

8.5 AIR INLET SYSTEM WITH OIL INJECTION INLET VALVE

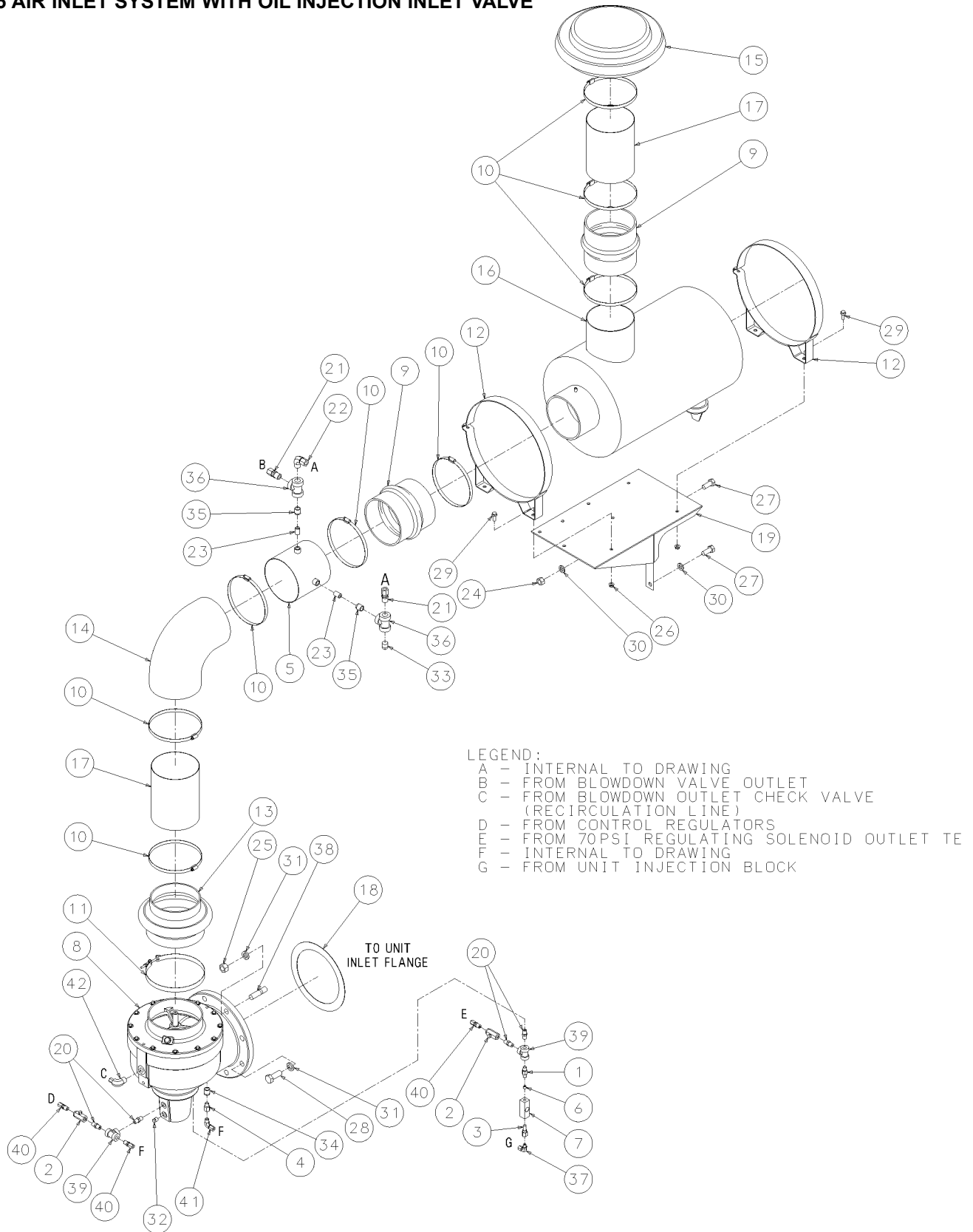

02250142-581R00

Section 8

ILLUSTRATIONS AND PARTS LIST

8.5 AIR INLET SYSTEM WITH OIL INJECTION INLET VALVE

key number	description	part number	quantity
1	orifice, .031" x .25m x .25m nptf	02250101-191	1
2	valve, check 1/4"nptf viton seat	02250110-557	2
3	filter, assembly genesis filter	02250117-782	1
4	orifice,.062 .25 fnpt x .25 mnpt	02250118-585	1
5	tube, 7" x 6.5" w/3/8" conn	02250120-368	1
6	orifice, plug brass 1/8"npt x 1/32"	02250125-774	1
7	sightglass, orf block sae	02250126-129	1
8	sub assembly, 8" inlet valve w/orifice (I)	02250140-758	1
9	hose, hump 7"	041917	2
10	clamp, hose 7"	041992	8
11	clamp, hose 8"	043598	1
12	band, mounting 16"	044248	2
13	adapter, red hump 8 x 7 x 6	045356	1
14	rubber elbow 7 i.d. x 90 deg.	046078	1
15	cap, air inlet 7"	046307	1
16	filter, inlet optimalair 16"odx7"intl (II)	048456	1
17	tube, alum air inlet 7"od x 9"lg	232591	2
18	gasket, asa flange 150# 8" (III)	240621-013	1
19	support, air inlet filter	250000-826	1
20	nipple, hx tbe 316s 1/4"	250018-760	4
21	connector, tube-m 1/2 x 1/2	810208-050	2
22	elbow, tube 90 deg m 1/2 x 1/2	810508-050	1
23	nipple, pipe-xs galv 3/8 x cl	823206-000	2
24	nut, hex pltd 5/8-11	825210-559	1
25	nut, hex pltd 3/4-10	825212-665	2
26	nut, hex f pltd 3/8-16	825306-347	4
27	capscr, hex gr5 5/8-11 x 1 1/2	829110-150	2
28	capscr, hex gr5 3/4-10 x 2	829112-200	6

(Continued on page 57)

(I) For maintenance on air inlet valve assembly no. 02250140-758, order repair kit no. 02250112-531.
NOTE: See footnote *(III)* below.

(II) For maintenance on air filter no. 048456, order primary replacement element no. 02250135-150 and secondary replacement element no. 048463.

(III) When performing maintenance on inlet valve, if required, order gasket no. 240621-013.

PLEASE NOTE: WHEN ORDERING PARTS, INDICATE THE SERIAL NUMBER OF COMPRESSOR

Section 8 ILLUSTRATIONS AND PARTS LIST

8.5 AIR INLET SYSTEM WITH OIL INJECTION INLET VALVE

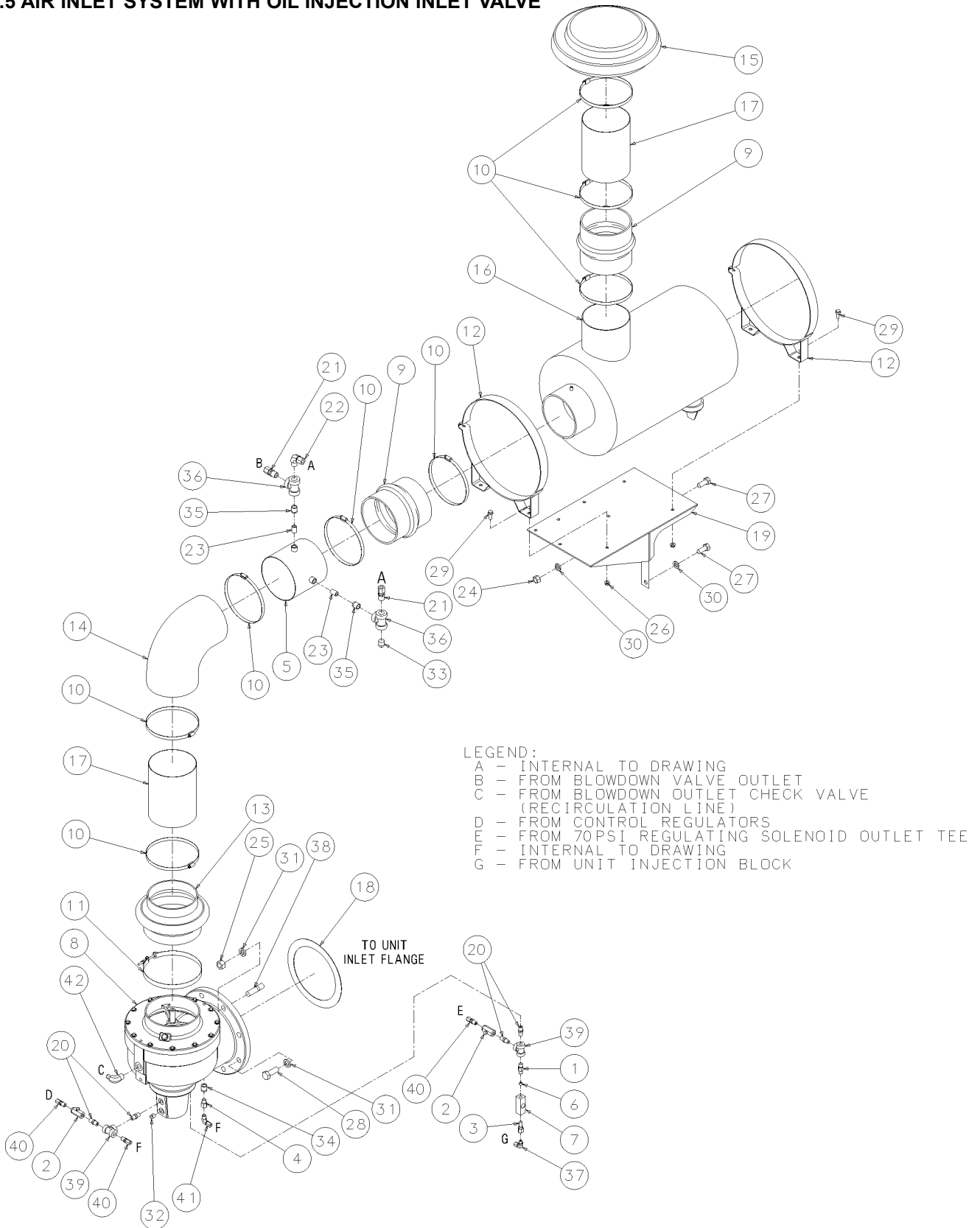

02250142-581R00

Section 8

ILLUSTRATIONS AND PARTS LIST

8.5 AIR INLET SYSTEM WITH OIL INJECTION INLET VALVE (CONTINUED)

<i>key</i> number	description	<i>part</i> number	quantity
29	screw, hex ser washer 3/8-16 x 1	829706-100	4
30	washer, spr lock reg pltd 5/8	837810-156	2
31	washer, spr lock reg pltd 3/4	837812-188	8
32	plug, pipe 1/4" 3000# stl plt	866900-010	1
33	plug, pipe 1/2" 3000# stl plt	866900-020	2
34	bushing, red pltd 1/2 x 1/4	867102-010	1
35	bushing, red pltd 1/2 x 3/8	867102-015	2
36	tee, pipe pltd 1/2	868430-020	2
37	elbow, tb-m str thd ss 1/4 x 7/16	870804-044	1
38	stud, threaded 3/4-10 x 3 plt	873812-030	2
39	tee, pipe 300# 1/4 ss	876730-010	2
40	connector, tube-m 1/4 x 1/4 ss	876804-025	3
41	elbow, tube 90 deg m 1/4 x 1/4 ss	877004-025	1
42	elbow, tube 90 deg m 1/4 x 1/2 ss	877004-050	1

PLEASE NOTE: WHEN ORDERING PARTS, INDICATE THE SERIAL NUMBER OF COMPRESSOR

Section 8 ILLUSTRATIONS AND PARTS LIST

8.6 FLUID COOLING SYSTEM- 300-450HP/ 224-336KW WATER-COOLED

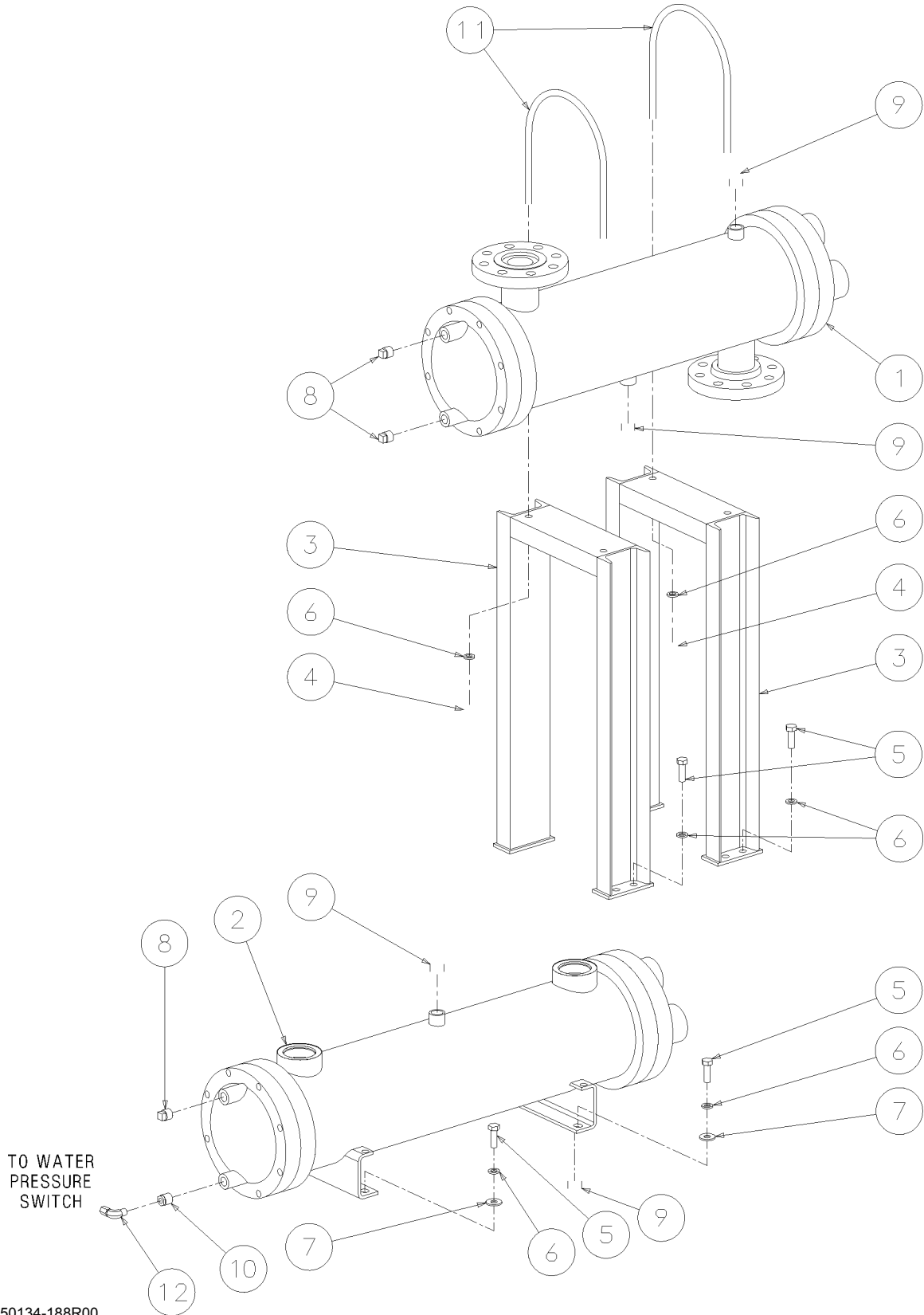

02250134-188R00

Section 8

ILLUSTRATIONS AND PARTS LIST

8.6 FLUID COOLING SYSTEM- 300-450HP/ 224-336KW WATER-COOLED

<i>key number</i>	<i>description</i>	<i>part number</i>	<i>quantity</i>
1	aftercooler, air/wtr 08030 400# 400hp	02250139-059	1
2	cooler, oil/wtr 08036 400# 400hp	02250139-060	1
3	support, cooler ls20ts aftclr 350#	02250139-203	2
4	nut, hex pltd 1/2-13	825208-448	4
5	capscr, hex gr5 1/2-13 x 1 1/2	829108-150	12
6	washer, spr lock reg pltd 1/2	837808-125	16
7	washer, pl-b reg pltd 1/2	838208-112	4
8	plug, pipe 1/2" 3000# stl plt	866900-020	3
9	plug, pipe 3/4" 3000# stl plt	866900-030	4
10	bushing, red pltd 1/2 x 1/4	867102-010	1
11	u-bolt, 1/2" x 8" pipe pltd	868308-800	2
12	elbow, tube 90 deg m 1/4 x 1/4 ss	877004-025	1

PLEASE NOTE: WHEN ORDERING PARTS, INDICATE THE SERIAL NUMBER OF COMPRESSOR

Section 8 ILLUSTRATIONS AND PARTS LIST

8.7 AIR PIPING SYTEM- 300-450HP/ 224-336KW WATER-COOLED

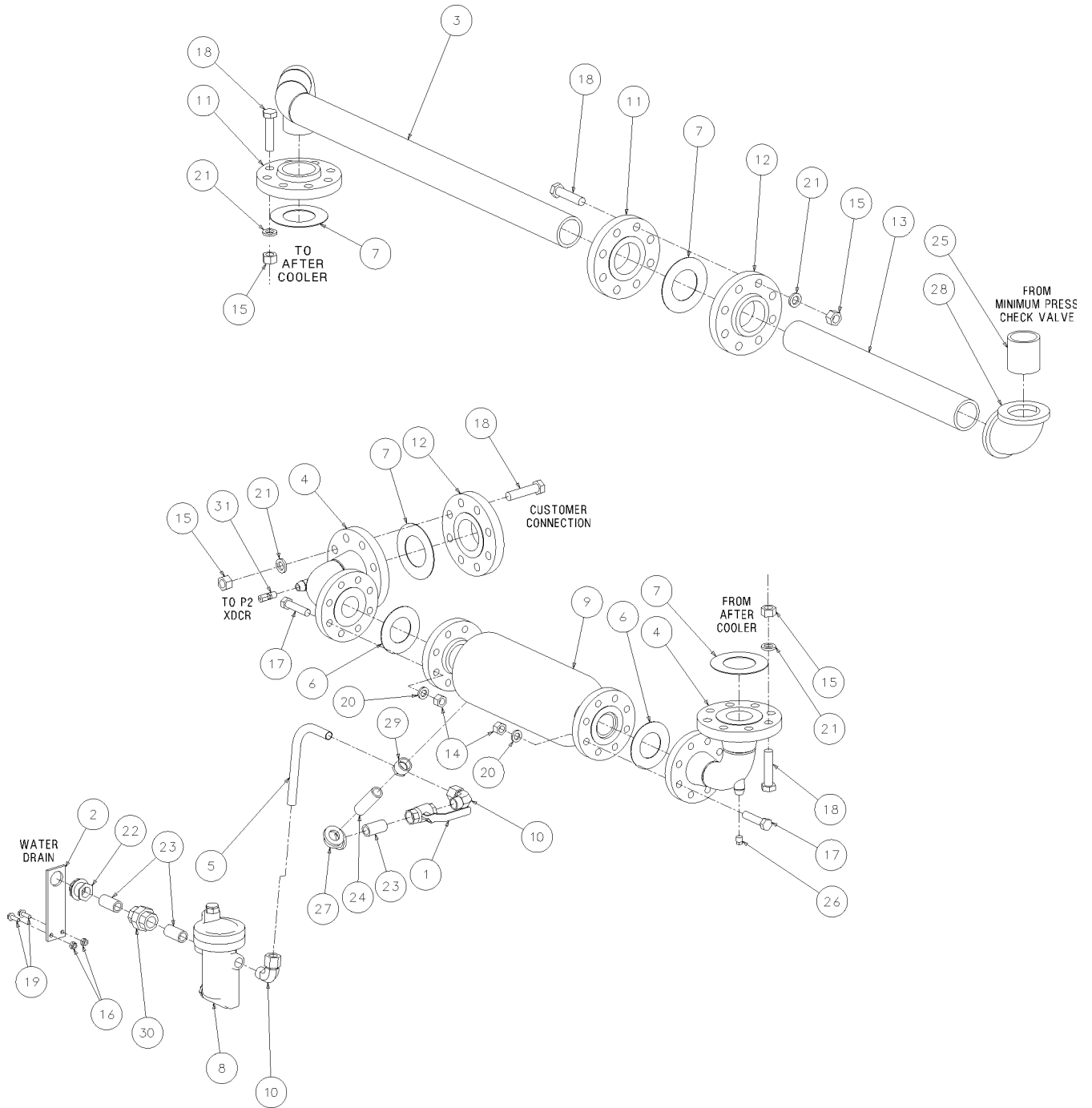

02250134-190R00

Section 8

ILLUSTRATIONS AND PARTS LIST

8.7 AIR PIPING SYTEM- 300-450HP/ 224-336KW WATER-COOLED

<i>key number</i>	<i>description</i>	<i>part number</i>	<i>quantity</i>
1	valve, ball 3/4" npt apollo	02250117-792	1
2	support, 3/4" cust conn mdrn ls20t	02250137-659	1
3	pipe, assembly ls20ts flg/clr 2-1/2	02250139-210	1
4	elbow, red 2-1/2 x 2 300#	02250139-598	2
5	tube, moistdr LS20TS wc	02250139-607	1
6	gasket, asa flange 300# 2"	240620-006	2
7	gasket, asa flange 300# 2-1/2"	240620-007	4
8	trap, auto 3/4"npt 400# max	250006-639	1
9	separator, water 2"w-a 311	406746	1
10	elbow, tube 90 deg m 3/4 x 3/4	810512-075	2
11	flange, slp-on 2 1/2" 300#	820230-040	2
12	flange, thrd 2 1/2" 300# rf	820330-040	2
13	nipple, pipe-xs 2 1/2 x 24	822240-240	1
14	nut, hex pltd 5/8-11	825210-559	16
15	nut, hex pltd 3/4-10	825212-665	32
16	nut, hex f pltd 5/16-18	825305-283	2
17	capscr, hex gr5 5/8-11 x 2 3/4	829110-275	16
18	capscr, hex gr5 3/4-10 x 3 1/4	829112-325	32
19	screw, hex ser washer 5/16-18 x 1	829705-100	2
20	washer, spr lock reg pltd 5/8	837810-156	16
21	washer, spr lock reg pltd 3/4	837812-188	32
22	bulkhead, pipe 3/4" npt	841500-012	1
23	nipple, pipe-xs plt 3/4 x 2	866412-020	3
24	nipple, pipe-xs plt 3/4 x 3 1/2	866412-035	1
25	nipple, pipe-xs plt 2 1/2 x 3	866440-030	1
26	plug, pipe 1/4" 3000# stl plt	866900-010	1
27	elbow, pipe 90 deg 300# plt 3/4"	867030-030	1
28	elbow, pipe 90 deg 300# plt 2 1/2"	867030-100	1
29	bushing, red pltd 1 x 3/4	867104-030	1
30	union, pipe-brs seat 3/4 gal 300#	873530-030	1
31	connector, tube-m 1/4 x 1/4 ss	876804-025	1

PLEASE NOTE: WHEN ORDERING PARTS, INDICATE THE SERIAL NUMBER OF COMPRESSOR

Section 8 ILLUSTRATIONS AND PARTS LIST

8.8 FLUID PIPING SYSTEM- 300-450HP/ 224-336KW WATER-COOLED

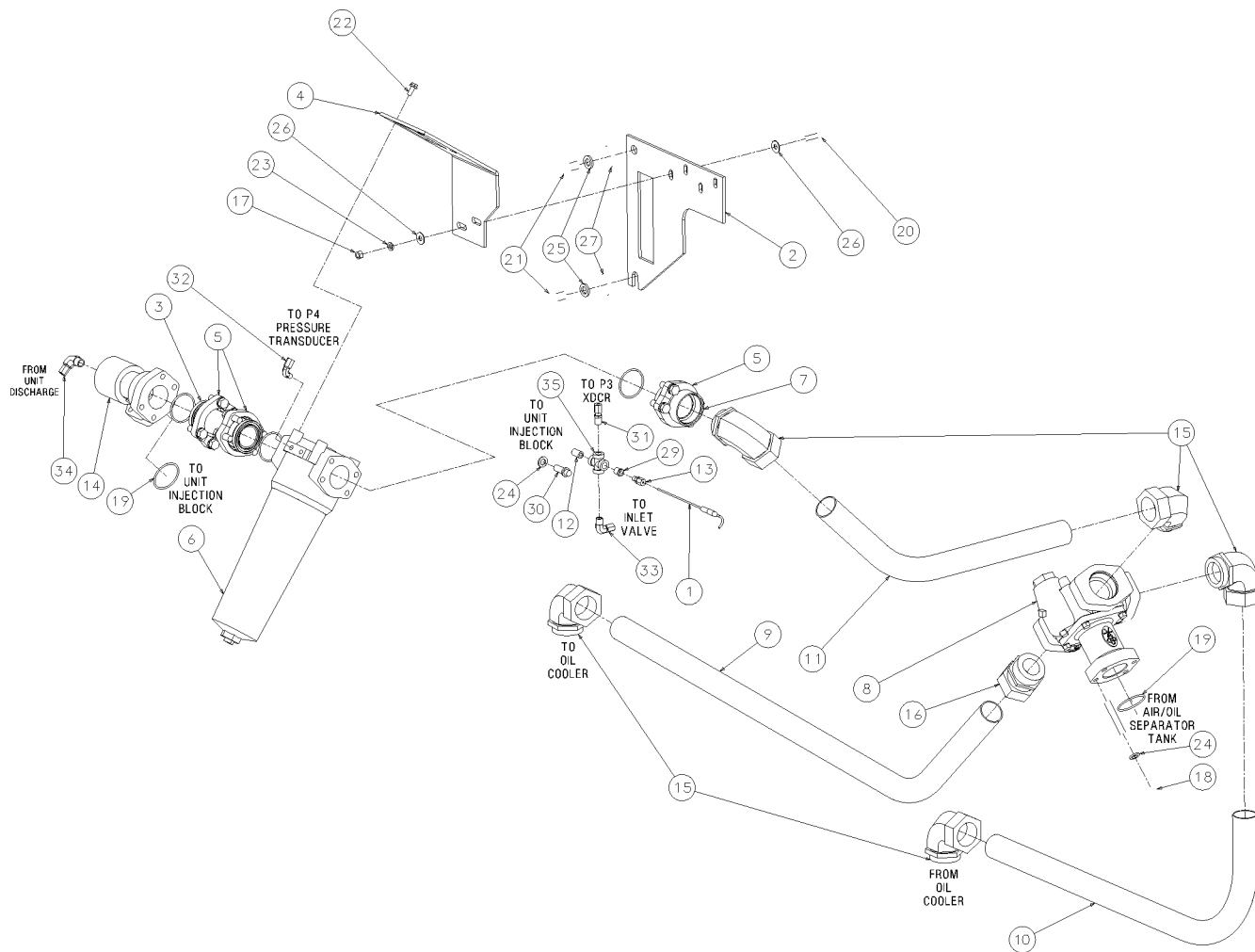

02250134-198R01

Section 8

ILLUSTRATIONS AND PARTS LIST

8.8 FLUID PIPING SYSTEM- 300-450HP/ 224-336KW WATER-COOLED

<i>key number</i>	<i>description</i>	<i>part number</i>	<i>quantity</i>
1	probe, rtd 100 ohm plat 6"x 12ft	02250058-087	1
2	mounting, bracket oil filter 20/12	02250061-327	1
3	tube, oil stop valve adapter	02250075-105	1
4	mt. filter 80cn full flow	02250075-158	1
5	flange, kit sae splt 2" - viton	02250099-415	3
6	filter, oil assy parker (I)	02250111-592	1
7	flange, adapter 2" face/2-1/2"sae	02250139-129	1
8	valve, thermal 220f 2-1/2"sae asy (II)	02250139-130	1
9	tube, thrmvlv/clr LS20TS wc	02250139-601	1
10	tube, clr/thrmvlv LS20TS wc	02250139-603	1
11	tube , thrmvlv/fit LS20TS wc	02250139-605	1
12	nipple, pipe-xs 316s 1/4 x cl	250019-142	1
13	fitting, compress adj	250028-635	1
14	valve, 2" oil stop 4-bolt flange (III)	250041-069	1
15	elbow, tube str thrd 2 x 2 1/2	811632-250	5
16	connector, tube str thd 2 x 2 1/2	811832-250	1
17	nut, hex pltd 3/8-16	825206-337	2
18	nut, hex pltd 1/2-13	825208-448	4
19	o-ring, viton 2 1/4 x 1/8"	826502-228	3
20	capscr, hex gr5 3/8-16 x 1 1/4	829106-125	2
21	capscr, hex gr5 5/8-11 x 1	829110-100	2
22	screw, hex ser washer 5/16-18 x 3/4	829705-075	4
23	washer, spr lock reg pltd 3/8	837806-094	2
24	washer, spr lock reg pltd 1/2	837808-125	8
25	washer, spr lock reg pltd 5/8	837810-156	2
26	washer, pl-b reg pltd 3/8	838206-071	4
27	washer, pl-b reg pltd 5/8	838210-112	2
28	stud, threaded 1/2-13 x 3	839408-030	4
29	bushing, red pltd 1/4 x 1/8	867100-005	1
30	capscrew, ferry head hd pltd 1/2-13 x 1 1/4	867308-125	4

(Continued on page 65)

(I) For maintenance on oil filter assembly no. 02250111-592, order repair kit no. 250031-850.

(II) For maintenance on thermal valve no. 02250139-130, order repair kit no. 02250139-865.

(III) for maintenance on fluid stop valve no. 250041-069, order repair kit no. 02250051-747.

PLEASE NOTE: WHEN ORDERING PARTS, INDICATE THE SERIAL NUMBER OF COMPRESSOR

Section 8 ILLUSTRATIONS AND PARTS LIST

8.8 FLUID PIPING SYSTEM- 300-450HP/ 224-336KW WATER-COOLED

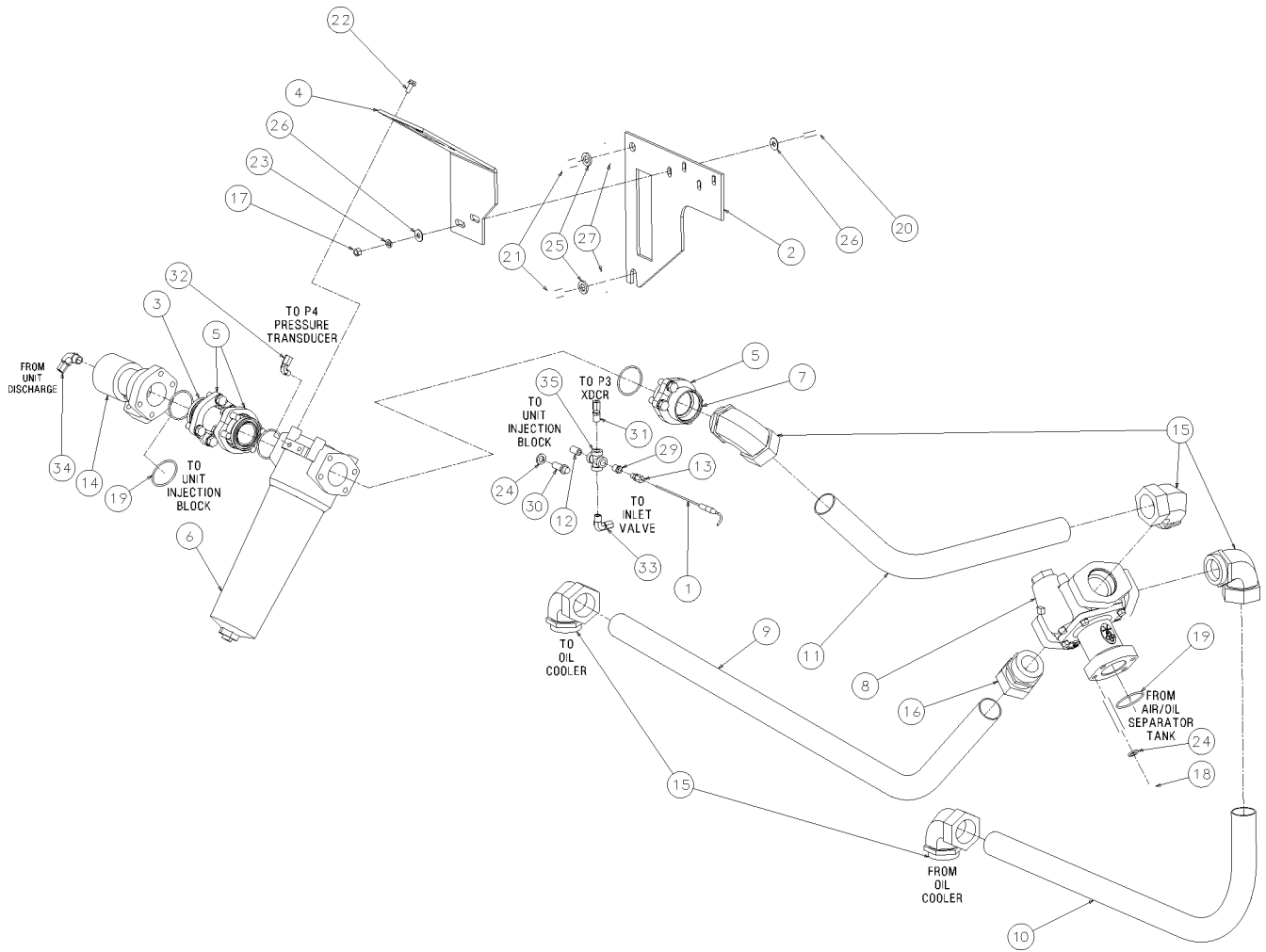

02250134-198R01

Section 8

ILLUSTRATIONS AND PARTS LIST

8.8 FLUID PIPING SYSTEM- 300-450HP/ 224-336KW WATER-COOLED (CONTINUED)

<i>key number</i>	<i>description</i>	<i>part number</i>	<i>quantity</i>
31	connector, tube-m 1/4 x 1/4 ss	876804-025	1
32	elbow, tube 90 deg m 1/4 x 1/8 ss	877004-012	1
33	elbow, tube 90 deg m 1/4 x 1/4 ss	877004-025	1
34	elbow, tube 90 deg m 1/4 x 3/8 ss	877004-038	1
35	cross, pipe 1/4" 2000# ss	879000-010	1

PLEASE NOTE: WHEN ORDERING PARTS, INDICATE THE SERIAL NUMBER OF COMPRESSOR

Section 8 ILLUSTRATIONS AND PARTS LIST

8.9 DISCHARGE SYSTEM

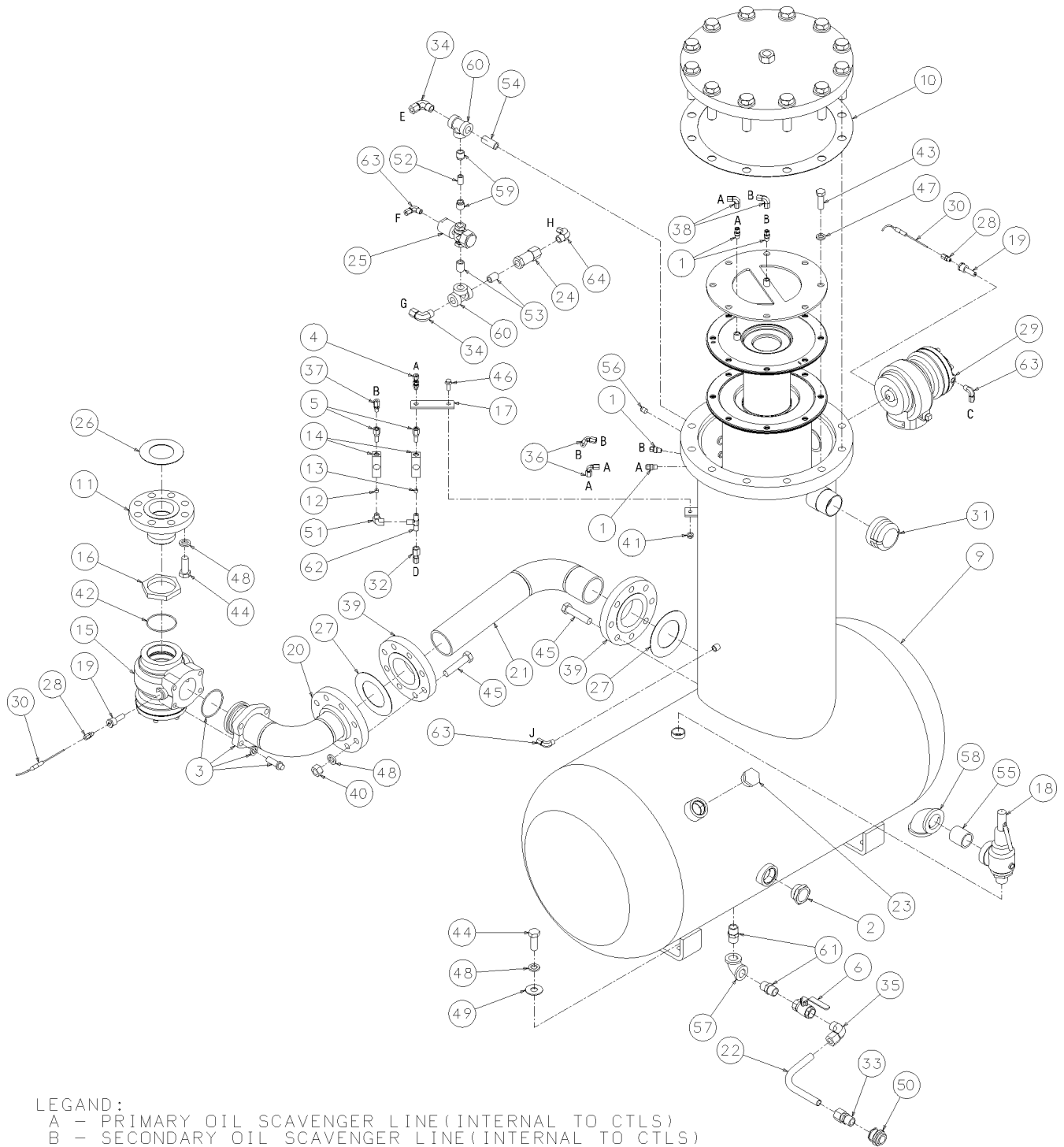

LEGAND:

- A - PRIMARY OIL SCAVENGER LINE (INTERNAL TO CTLS)
- B - SECONDARY OIL SCAVENGER LINE (INTERNAL TO CTLS)
- C - FROM 60PSI CONTROL LINE
- D - TO UNIT SECOND STAGE
- E - TO CONTROL LINE FILTER
- F - FROM BLOWDOWN SOLENOID VALVE
- G - TO INLET TUBE
- H - TO INLET POPPET VALVE
- J - TO P1 TRANSDUCER

02250138-950R01

Section 8 ILLUSTRATIONS AND PARTS LIST

8.9 DISCHARGE SYSTEM

<i>key number</i>	<i>description</i>	<i>part number</i>	<i>quantity</i>
1	connector, flex 1/4t x 1/4p	020169	4
2	plug, sight glass 1-7/8" sae	02250097-611	1
3	flange, kit sae splt 3" - viton	02250100-926	1
4	connector, tube male bhd 1/4 x sae	02250101-490	1
5	filter, assembly genesis filter (I)	02250117-782	2
6	valve, ball 3/4" npt apollo	02250117-792	1
7	element, sep/pri LS20TS 500# (II)	02250119-666	1
8	element, sep/sec LS20TS 500# (II)	02250119-667	1
9	tank, air/oil 24" t-tnk 400psig	02250119-805	1
10	gasket, sep LS20T 16" flange	02250121-188	1
11	adapter, discharge vlv m85 ddh204 hp	02250124-030	1
12	orifice, plug brass 1/8"npt x 1/32"	02250125-774	1
13	orifice, plug brass 1/8"npt x 3/32"	02250125-776	1
14	sightglass, orf block sae	02250126-129	2
15	valve, assy 3" x m85 (III)	02250127-507	1
16	nut, hex m85-2 6h	02250130-997	1
17	plate, scav line assy - LSF20T	02250132-464	1
18	valve, relief 1" npt 400psi	02250137-688	1
19	sleeve, rtd 1/2"npt LS20T disch	02250138-457	2
20	pipe, discharge assy LS20TS 350#	02250139-146	1
21	pipe, discharge assy LS20TS 350#	02250139-246	1
22	tube, sump drain LS20TS	02250139-622	1
23	plug, o-ring boss sae 1 1/4	040029	1
24	valve, check 1/2"	042694	1
25	valve, pneu (nc) 500# rn bdv(IV)	045116	1

(Continued on page 69)

(I) For maintenance on filter assembly no. 02250117-782, order replacement filter assembly no. 02250117-782.

(II) For maintenance on separator, order primary replacement element/gasket kit no. 02250122-833, and secondary replacement element no. 02250122-832.

(III) For maintenance on assembly valve no. 02250127-507, order repair kit no. 606208-001.

(IV) For maintenance on pneumatic valve no. 045116, order repair kit no. 047524.

PLEASE NOTE: WHEN ORDERING PARTS, INDICATE THE SERIAL NUMBER OF COMPRESSOR

Section 8 ILLUSTRATIONS AND PARTS LIST

8.9 DISCHARGE SYSTEM

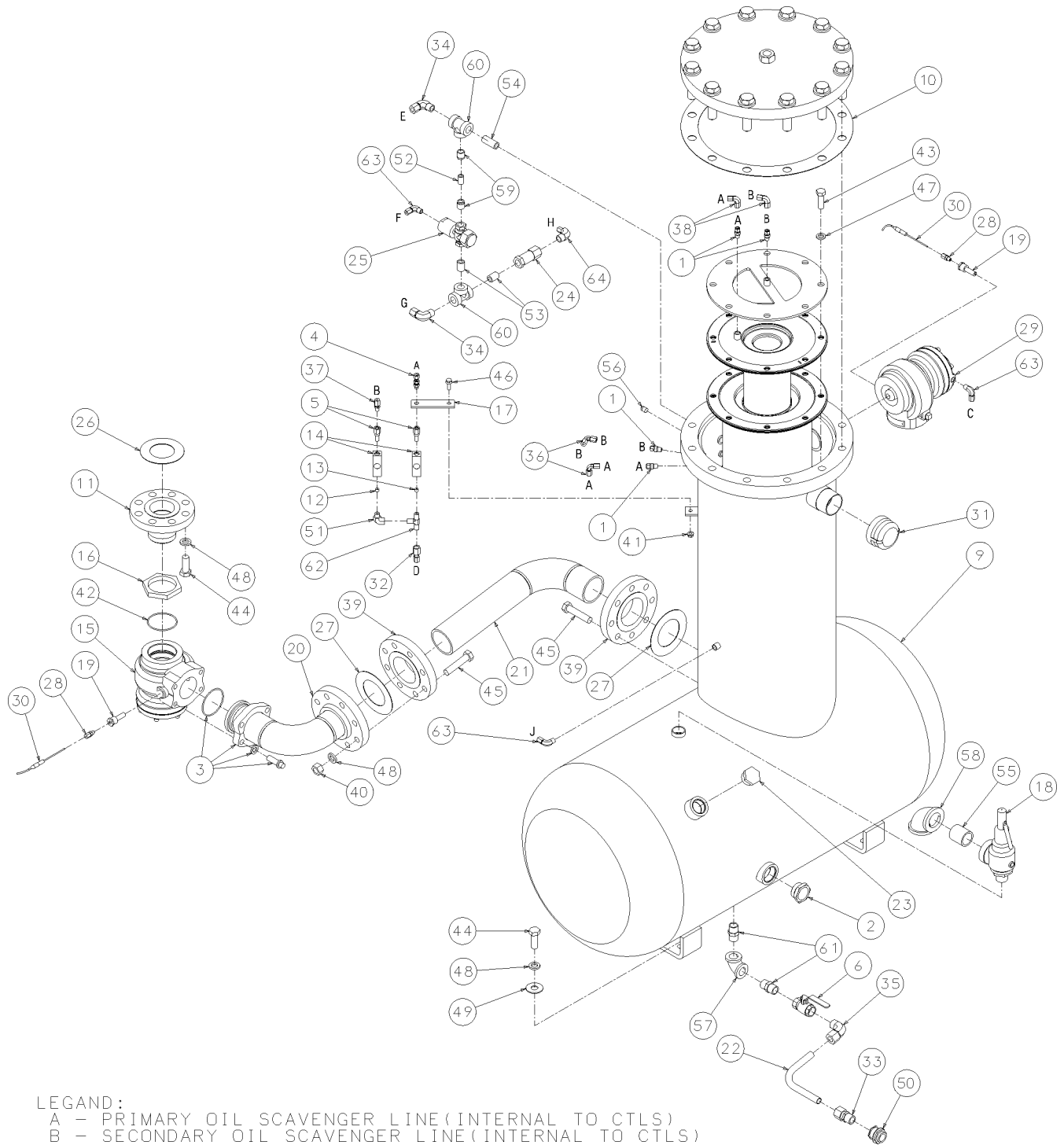

- LEGEND:
- A - PRIMARY OIL SCAVENGER LINE (INTERNAL TO CTLS)
 - B - SECONDARY OIL SCAVENGER LINE (INTERNAL TO CTLS)
 - C - FROM 60PSI CONTROL LINE
 - D - TO UNIT SECOND STAGE
 - E - TO CONTROL LINE FILTER
 - F - FROM BLOWDOWN SOLENOID VALVE
 - G - TO INLET TUBE
 - H - TO INLET POPPET VALVE
 - J - TO P1 TRANSDUCER

02250138-950R01

Section 8 ILLUSTRATIONS AND PARTS LIST

8.9 DISCHARGE SYSTEM (CONTINUED)

<i>key number</i>	<i>description</i>	<i>part number</i>	<i>quantity</i>
26	gasket, asa flange 300# 2-1/2"	240620-007	1
27	gasket, asa flange 300# 3"	240620-008	2
28	fitting, compress adj	250028-635	2
29	sub assembly, vlv min press/chk asm (2.5") (V)	250031-852	1
30	probe,rtd 100 ohm plat 3.5"x 12ft	250039-909	2
31	cap, pipe 2 1/2 300#	806130-100	1
32	connector, tube-f 1/4 x 1/4	810104-025	1
33	connector, tube-m 3/4 x 3/4	810212-075	1
34	elbow, tube 90 deg m 1/2 x 1/2	810508-050	2
35	elbow, tube 90 deg m 3/4 x 3/4	810512-075	1
36	elbow, tube union 1/4	811204-025	2
37	connector, tube str thd 1/4 x 7/16	811804-044	1
38	elbow, tube union 1/4	812704-025	2
39	flange, slp-on 3" 300#	820230-048	2
40	nut, hex pltd 3/4-10	825212-665	16
41	nut, hex f pltd 3/8-16	825306-347	1
42	o-ring, viton 3 1/4 x 1/8"	826502-236	1
43	capscr, hex gr5 5/8-11 x 2	829110-200	8
44	capscr, hex gr5 3/4-10 x 2	829112-200	12
45	capscr, hex gr5 3/4-10 x 3 1/2	829112-350	16
46	screw, hex ser washer 3/8-16 x 1	829706-100	1
47	washer, spr lock reg pltd 5/8	837810-156	8
48	washer, spr lock reg pltd 3/4	837812-188	28
49	washer, pl-b reg pltd 3/4	838212-112	4
50	bulkhead, pipe 3/4" npt	841500-012	1
51	elbow, pipe 90m/f 1/4 x 1/4	860704-025	1
52	nipple, pipe-xs plt 3/8 x cl	866406-000	1
53	nipple, pipe-xs plt 1/2 x cl	866408-000	2
54	nipple, pipe-xs plt 1/2 x 2	866408-020	1
55	nipple, pipe-xs plt 1 1/2 x 2	866424-020	1

(Continued on page 71)

(V) For maintenance on minimum pressure check valve assembly no. 250031-852, consult factory for repair kit number.

PLEASE NOTE: WHEN ORDERING PARTS, INDICATE THE SERIAL NUMBER OF COMPRESSOR

Section 8 ILLUSTRATIONS AND PARTS LIST

8.9 DISCHARGE SYSTEM

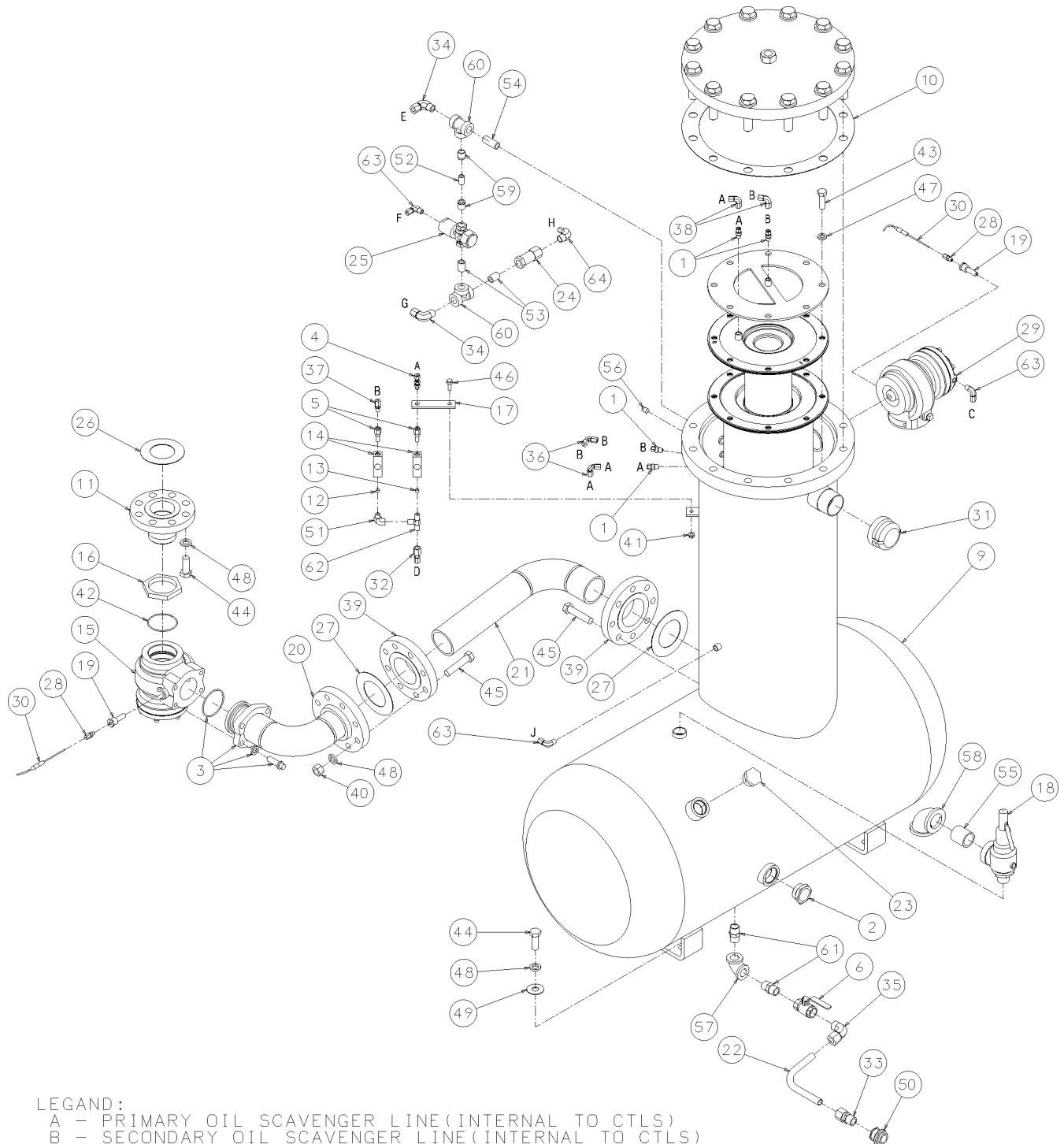

- LEGEND:
- A - PRIMARY OIL SCAVENGER LINE (INTERNAL TO CTLS)
 - B - SECONDARY OIL SCAVENGER LINE (INTERNAL TO CTLS)
 - C - FROM 60PSI CONTROL LINE
 - D - TO UNIT SECOND STAGE
 - E - TO CONTROL LINE FILTER
 - F - FROM BLOWDOWN SOLENOID VALVE
 - G - TO INLET TUBE
 - H - TO INLET POPPET VALVE
 - J - TO P1 TRANSDUCER

02250138-950R01

Section 8 ILLUSTRATIONS AND PARTS LIST

8.9 DISCHARGE SYSTEM (CONTINUED)

<i>key number</i>	<i>description</i>	<i>part number</i>	<i>quantity</i>
56	plug, pipe 1/4" 3000# stl plt	866900-010	1
57	elbow, pipe 90 deg 300# plt 3/4"	867030-030	1
58	elbow, pipe 90 deg 300# plt 1 1/2"	867030-060	1
59	bushing, red pltd 1/2 x 3/8	867102-015	2
60	tee, pipe pltd 1/2	868430-020	2
61	nipple, pipe-hx pltd 3/4 x 3/4	868512-075	2
62	tee, male pipe brass 1/4	869825-025	1
63	elbow, tube 90 deg m 1/4 x 1/4 ss	877004-025	3
64	elbow, tube 90 deg m 1/4 x 1/2 ss	877004-050	1

PLEASE NOTE: WHEN ORDERING PARTS, INDICATE THE SERIAL NUMBER OF COMPRESSOR

Section 8 ILLUSTRATIONS AND PARTS LIST

8.10 CONTROL/START SYSTEM

<i>key number</i>	<i>description</i>	<i>part number</i>	<i>quantity</i>
1	filter, coalescing 425 psi @ 265deg (I)	02250058-442	1
2	locknut, n4 conduit sealing	02250071-362	3
3	grip, cord n4 .125-.187 x 1/2"	02250071-379	4
4	grip, cord n4 .250-.375 x 1/2"	02250071-381	5
5	switch, vacuum 22"wc n4 6ft cable 5a	02250078-249	1
6	transducer, pressure 0-500psi 1-5vdc n4	02250085-652	4
7	orifice, .040 1/4fnpt x 1/4mnpt	02250091-395	1
8	support, pressure transducer n4	02250102-631	1
9	valve, check 1/4"nptf viton seat	02250110-557	1
10	gage, air press 2 1/2" 0-200 psi	02250117-009	2
11	valve, solenoid 3wno 1/4 235# n4 (II)	02250125-657	1
12	valve, pressure reducing 1/4" vit 2-150# (III)	02250139-030	2
13	bracket, pipe"l"1/8"-1"pipe-dc	044831	3
14	valve, regulator (IV)	045099	1
15	valve, regulator 400 psi (V)	048059	1
16	nipple, conduit 1/2 x 1.5"	250007-169	3
17	grip, cord so 12/4 st 1/2"	250018-495	1
18	nipple, hx tbe 316s 1/4"	250018-760	5
19	nipple, pipe-xs 316s 1/4 x cl	250019-142	3
20	support, starter&clr 200hp	250022-657	2
21	tee, 1/4"t x m-rn 316ss	250041-911	2
22	valve, sol 3wno 1/8 8300 (VI)	407390	2
23	connector, tube-m 1/4 x 1/8	813604-125	1
24	nut, hex pltd 3/8-16	825206-337	4
25	nut, hex f pltd 1/4-20	825304-236	6

(Continued on page 75)

(I) For maintenance on filter no. 02250058-442, order replacement element no. 02250058-441.

(II) For maintenance on solenoid valve no. 02250125-657, order repair kit no. 02250125-829, and replacement coil no. 02250125-861.

(III) For maintenance on pressure reducing valve no. 02250139-030, order repair kit no. 02250139-037.

(IV) For maintenance on pressure regulator valve no. 045099, order repair kit no. 048409.

(V) For maintenance on regulator valve no. 048059, order repair kit no. 048409.

(VI) For maintenance on solenoid valve no. 407390, order repair kit no. 02250053-830, and replacement coil no. 250031-431.

PLEASE NOTE: WHEN ORDERING PARTS, INDICATE THE SERIAL NUMBER OF COMPRESSOR

Section 8 ILLUSTRATIONS AND PARTS LIST

8.10 CONTROL/START SYSTEM

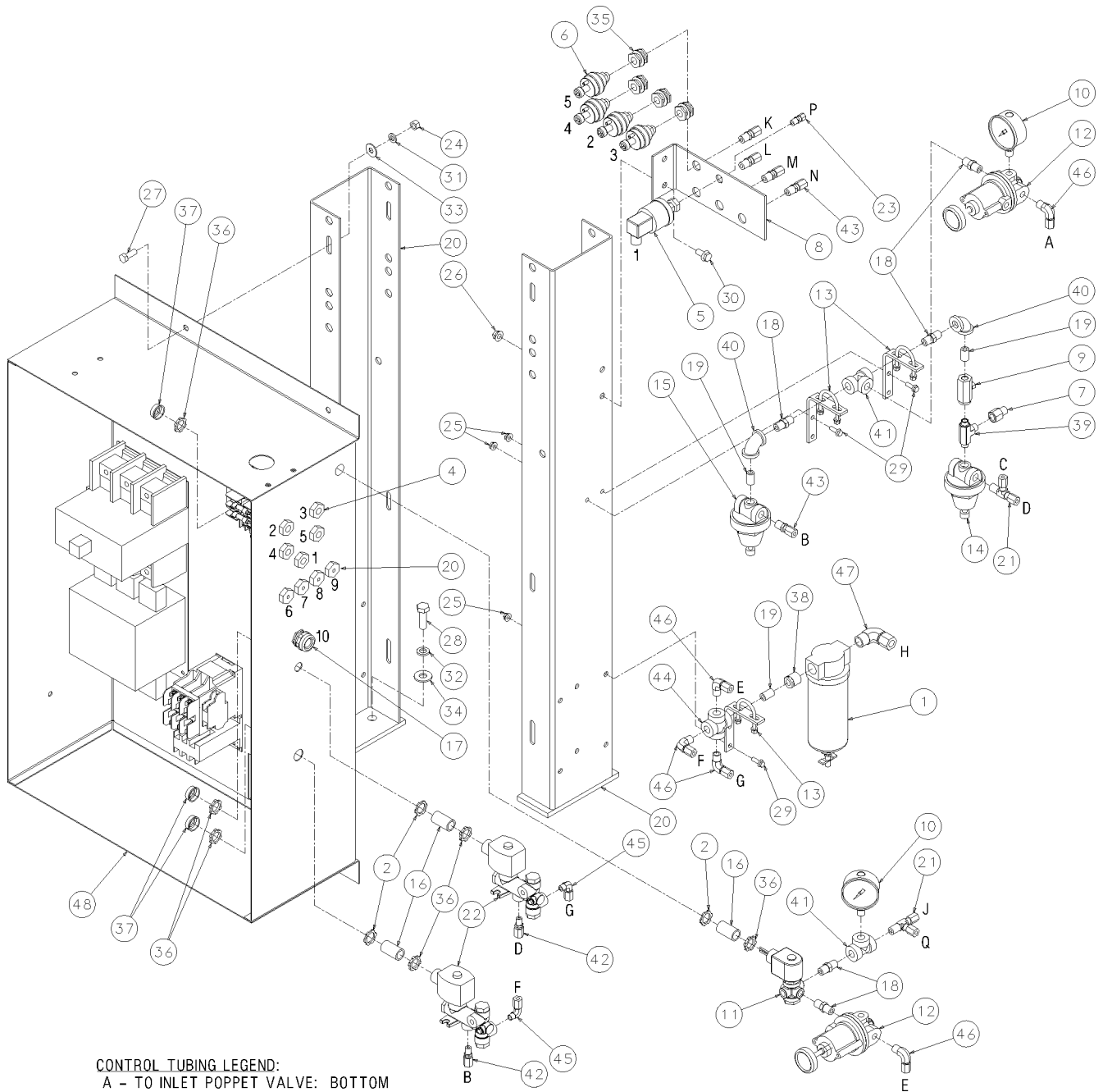

CONTROL TUBING LEGEND:

- A - TO INLET POPPET VALVE: BOTTOM
- B - INTERNAL TO CONTROLS
- C - TO BLOWDOWN VALVE: PILOT
- D - INTERNAL TO CONTROLS
- E - INTERNAL TO CONTROLS
- F - INTERNAL TO CONTROLS
- G - INTERNAL TO CONTROLS
- H - FROM DRY SIDE: AIR/OIL SEPARATOR TANK
- J - TO INLET POPPET VALVE: BACK
- K - FROM HIGH OIL PRESSURE: OIL FILTER INLET
- L - FROM LOW OIL PRESSURE: UNIT INJECTION BLOCK
- M - FROM HIGH SUMP/WET SIDE: AIR/OIL SEPARATOR TANK
- N - FROM MOISTURE SEPARATOR OUTLET
- P - FROM INLET AIR FILTER
- Q - TO MINIMUM PRESSURE VALVE PILOT

ELECTRICAL LEGEND:

- 1 - INLET FILTER VACUUM SWITCH
- 2 - P1: SUMP PRESSURE TRANSDUCER
- 3 - P2: LINE PRESSURE TRANSDUCER
- 4 - P3: UNIT INJECTION PRESSURE TRANSDUCER
- 5 - P4: FILTER INJECTION PRESSURE TRANSDUCER
- 6 - T1 RTD: UNIT DISCHARGE TEMPERATURE
- 7 - T2 RTD: DRY SIDE SUMP TEMPERATURE
- 8 - T3 RTD: UNIT INJECTION OIL TEMPERATURE
- 9 - T4 RTD: UNIT INTERSTAGE TEMPERATURE
- 10 - AIR COOLED PACKAGE: FAN MOTOR
(WATER COOLED PACKAGE: WATER PRESSURE SWITCH)

02250139-578R00

Section 8 ILLUSTRATIONS AND PARTS LIST

8.10 CONTROL/START SYSTEM (CONTINUED)

<i>key number</i>	<i>description</i>	<i>part number</i>	<i>quantity</i>
26	nut, hex f pltd 3/8-16	825306-347	2
27	capscr, hex gr5 3/8-16 x 1	829106-100	4
28	capscr, hex gr5 1/2-13 x 1 1/2	829108-150	4
29	screw, hex ser washer 1/4-20 x 3/4	829704-075	6
30	screw, hex ser washer 3/8-16 x 3/4	829706-075	2
31	washer, spr lock reg pltd 3/8	837806-094	4
32	washer, spr lock reg pltd 1/2	837808-125	4
33	washer, pl-b reg pltd 3/8	838206-071	4
34	washer, pl-b reg pltd 1/2	838208-112	4
35	bulkhead, pipe 1/4" npt	841500-004	4
36	locknut, conduit 1/2	847200-050	6
37	bushing, conduit plastic 1/2	848815-050	3
38	bushing, red pltd 1/2 x 1/4	867102-010	1
39	tee, male pipe stainless 1/4	869925-025	1
40	elbow, pipe 90 deg 1/4" 300# ss	876630-010	2
41	tee, pipe 300# 1/4 ss	876730-010	2
42	connector, tube-m 1/4 x 1/8 ss	876804-012	2
43	connector, tube-m 1/4 x 1/4 ss	876804-025	5
44	cross, pipe 1/4" 300# ss	876930-010	1
45	elbow, tube 90 deg m 1/4 x 1/8 ss	877004-012	2
46	elbow, tube 90 deg m 1/4 x 1/4 ss	877004-025	5
47	elbow, tube 90 deg m 1/2 x 1/2 ss	877008-050	1
48	starter, nc n12 (VI)	-	1

(VI) Starter may vary. Consult factory with machine serial number to determine correct starter part number.

PLEASE NOTE: WHEN ORDERING PARTS, INDICATE THE SERIAL NUMBER OF COMPRESSOR

Section 8 ILLUSTRATIONS AND PARTS LIST

8.11 CONTROL PANEL

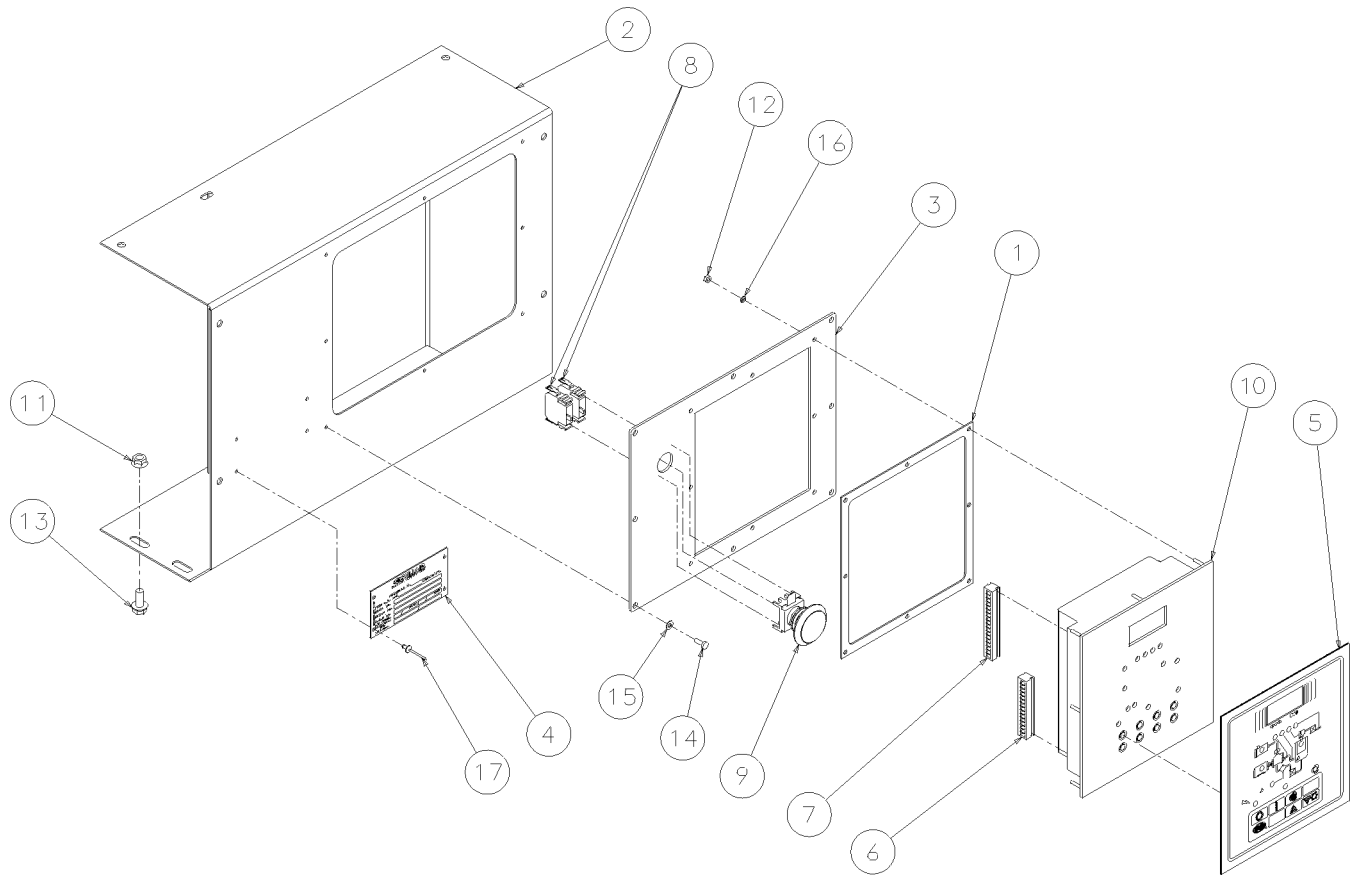

Section 8 ILLUSTRATIONS AND PARTS LIST

8.11 CONTROL PANEL

<i>key number</i>	<i>description</i>	<i>part number</i>	<i>quantity</i>
1	gasket, panel Supervisor II	02250048-822	1
2	panel, instrument Supervisor II	02250054-853	1
3	panel, cover Supervisor II	02250054-854	1
4	nameplate, Sullair serial number	02250059-318	1
5	decal, LS Super 2 front (I) (II)	02250116-245	1
6	harness, wire sii dlx std pwr	02250105-438	1
7	harness, wire s2 dlx ctl	02250105-439	1
8	block, contact 1nc	250027-125	2
9	switch, per red push/pull e22	250028-588	1
10	control, Supervisor II deluxe (II)	250042-023	1
11	nut, hex f pltd 5/16-18	825305-283	4
12	nut, hex metric m4 x .7	825904-070	8
13	screw, hex ser washer 5/16-18 x 3/4	829705-075	4
14	screw, tc-f pan #8-32 x 1/2	835601-050	8
15	washer, lock ext tooth #8	838401-023	8
16	washer, spr lock-metric pltd m4	838804-090	8
17	rivet, pop 1/8 x 3/8	843102-038	4

(I) For detail of Supervisor II panel decal, see *Figure 2-6, Supervisor II Panel* in **Section 2, Description**.

(II) Use replacement kit no. 02250143-166 for items 5 and 10 assembled with programming.

PLEASE NOTE: WHEN ORDERING PARTS, INDICATE THE SERIAL NUMBER OF COMPRESSOR

Section 8 ILLUSTRATIONS AND PARTS LIST

8.12 ENCLOSURE AND ENCLOSURE DECALS

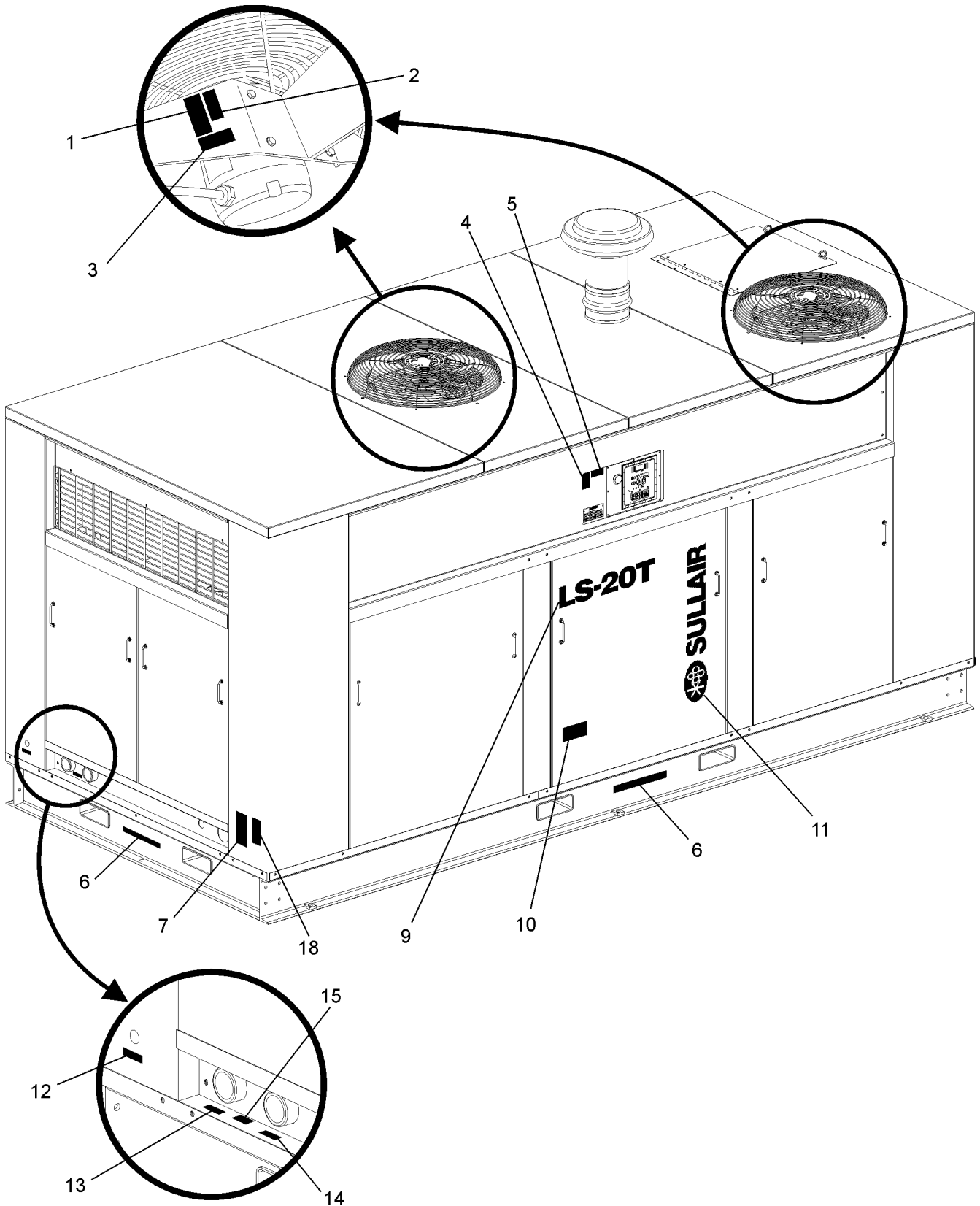

Section 8

ILLUSTRATIONS AND PARTS LIST

8.12 ENCLOSURE AND ENCLOSURE DECALS

NOTE

The Enclosure Section was not available at time of print. For breakdown of Enclosure assemblies for water-cooled models, please consult factory.

<i>key number</i>	<i>description</i>	<i>part number</i>	<i>quantity</i>
1	sign, warning "compressor fluid fill cap"	049685	2
2	sign, warning sever-fan port	049965	2
3	decal, rotation	250021-564	2
4	decal, warning auto start	250017-903	1
5	decal, autostart	041065	1
6	decal, fork lifting	241814	4
7	sign, warning "food grade" lube	250003-144	1
8	sign, air breathing (danger)	250027-935	1
9	decal, LS-16T black 4" ht.	02250071-282	1
10	decal, ISO 9001	02250057-624	1
11	decal, Sullair logo 4 x 32" black	02250059-060	1
12	decal, water drain	250022-810	1
13	decal, water in	250019-107	1
14	decal, water inlet-outlet	049873	1
15	decal, water out	250019-108	1

PLEASE NOTE: WHEN ORDERING PARTS, INDICATE THE SERIAL NUMBER OF COMPRESSOR

Section 8 ILLUSTRATIONS AND PARTS LIST

8.13 DECAL GROUP

⚠ DANGER



Death or serious injury can occur from inhaling compressed air without using proper safety equipment.
See OSHA standards on safety equipment.

250027-935

1

⚠ WARNING



Do not permit air from this equipment to contact food stuff except in full compliance with FDA Standard 21CFR178.3570, and all other applicable federal, state and local, codes, standards and regulations.

250003-144

2

⚠ WARNING



Use equipment grounding connector in accordance with the National Electrical Code, and all Federal State, and Local Codes, to help avoid possible ground fault shock hazard.

49852

3

⚠ WARNING



This Unit Is Equipped With An Auto Start Sequence That Will Start The Unit In The Event Of A Power Failure Automatically After The Sump Pressure Drops To 10 PSIG And The Power Is Restored.

When Performing Maintenance Follow Your Company's Prescribed Safety Practices for Electrical Equipment.

250017-903

4

⚠ DANGER



Lethal shock hazard inside.
Disconnect all power at source, before opening or servicing.

49850

5

⚠ WARNING



Hot surfaces.
To avoid burns, keep hands and all parts of the body away.

407408

6

⚠ WARNING



Disconnect all power at source, before attempting maintenance or adjustments.

49055

7

⚠ WARNING

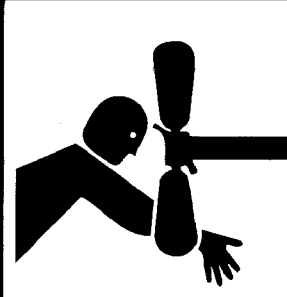

Do not operate without fan guard in place.

49965

8

Section 8 ILLUSTRATIONS AND PARTS LIST

8.13 DECAL GROUP

<i>key number</i>	<i>description</i>	<i>part number</i>	<i>quantity</i>
1	sign, air breathing (danger)	250027-935	1
2	sign, warning "food grade" lube	250003-144	1
3	sign, warning ground fault	049852	1
4	decal, warning auto start	250017-903	1
5	sign, danger electrocution	049850	1
6	sign, warning hot surfaces	407408	3
7	sign, warning sever - fan	049855	2
8	sign, warning sever-fan port	049965	2

(Continued on page 83)

PLEASE NOTE: WHEN ORDERING PARTS, INDICATE THE SERIAL NUMBER OF COMPRESSOR

**Section 8
ILLUSTRATIONS AND PARTS LIST**

8.13 DECAL GROUP

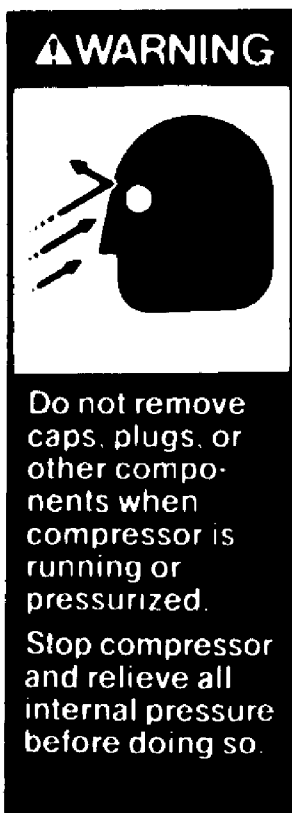

9

10

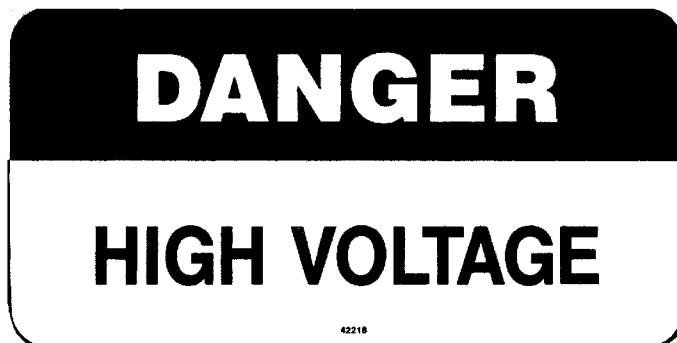

11

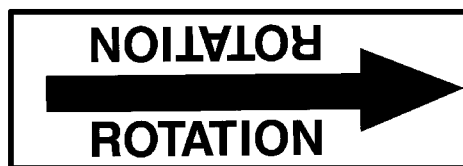

12

13

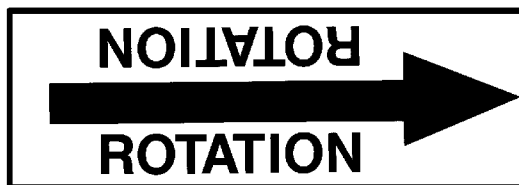

15



16



17



18

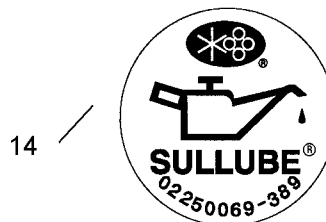

14

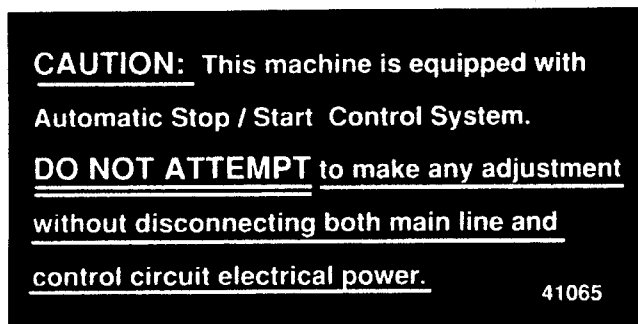

19

20



Section 8 ILLUSTRATIONS AND PARTS LIST

8.13 DECAL GROUP (CONTINUED)

<i>key number</i>	<i>description</i>	<i>part number</i>	<i>quantity</i>
9	sign, warning "compressor fluid fill cap"	049685	1
10	decal, danger high voltage	042218	1
11	decal, warning mixing fluids	02250110-891	1
12	decal, rotation	250021-286	1
13	decal, rotation	250021-564	1
14	decal, fluid Sullube	02250069-389	1
15	decal, water inlet-outlet	049873	1
16	decal, water in	250019-107	1
17	decal, water out	250019-108	1
18	decal, water drain	250022-810	1
19	decal, autostart	041065	1
20	decal, fork lifting	241814	4

(Continued on page 85)

PLEASE NOTE: WHEN ORDERING PARTS, INDICATE THE SERIAL NUMBER OF COMPRESSOR

Section 8 ILLUSTRATIONS AND PARTS LIST

8.13 DECAL GROUP

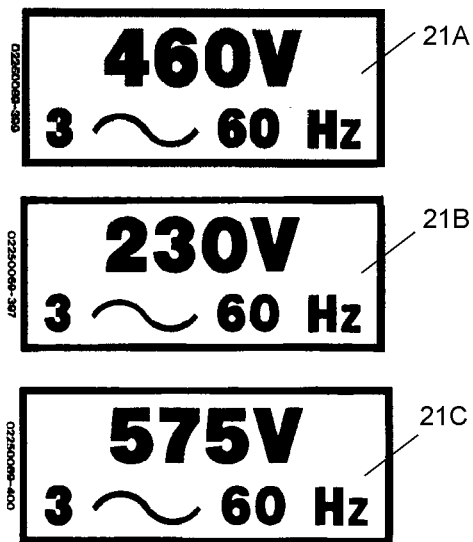

22

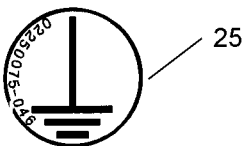
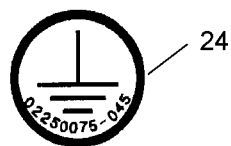

23

2500038-457	1 CR	1 TR	LINE PRESS	INLET
	2 CR	2 TR	DISCH PRESS	T1
	3 CR	3 TR	WATER PRESS	T2
	4 CR	4 TR	SEPARATOR	T3
	5 CR	1 M	SPIRAL VALVE	T4
	6 CR	2 M	INLET VALVE	T5
	1 FU	3 M	CIS VALVE	T6
	2 FU	4 M	OIL PRESS	T3
	3 FU	HCR	OIL FILTER	T4

27

LS-20T

28

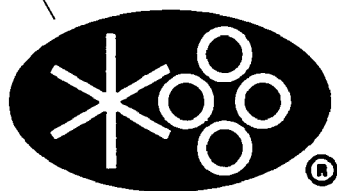

SULLAIR®

Section 8 ILLUSTRATIONS AND PARTS LIST

8.13 DECAL GROUP (CONTINUED)

<i>key number</i>	<i>description</i>	<i>part number</i>	<i>quantity</i>
21A	decal, V 460/3/60 international	02250069-399	1
21B	decal, V 230/3/60 international	02250069-397	1
21C	decal, V 575/3/60 international	02250069-400	1
22	decal, ISO 9001	02250057-624	1
23	decal, electrical component ID	250038-457	1
24	decal, protective earth ground	02250075-045	1
25	decal, earth ground	02250075-046	1
26	decal, PE designation	02250075-540	1
27	decal, LS-20T black 4" ht.	02250071-287	1
28	decal, Sullair logo 4 x 32" black	02250059-060	1

PLEASE NOTE: WHEN ORDERING PARTS, INDICATE THE SERIAL NUMBER OF COMPRESSOR

Section 8 ILLUSTRATIONS AND PARTS LIST

8.14 DECAL LOCATIONS- OPEN WATER-COOLED

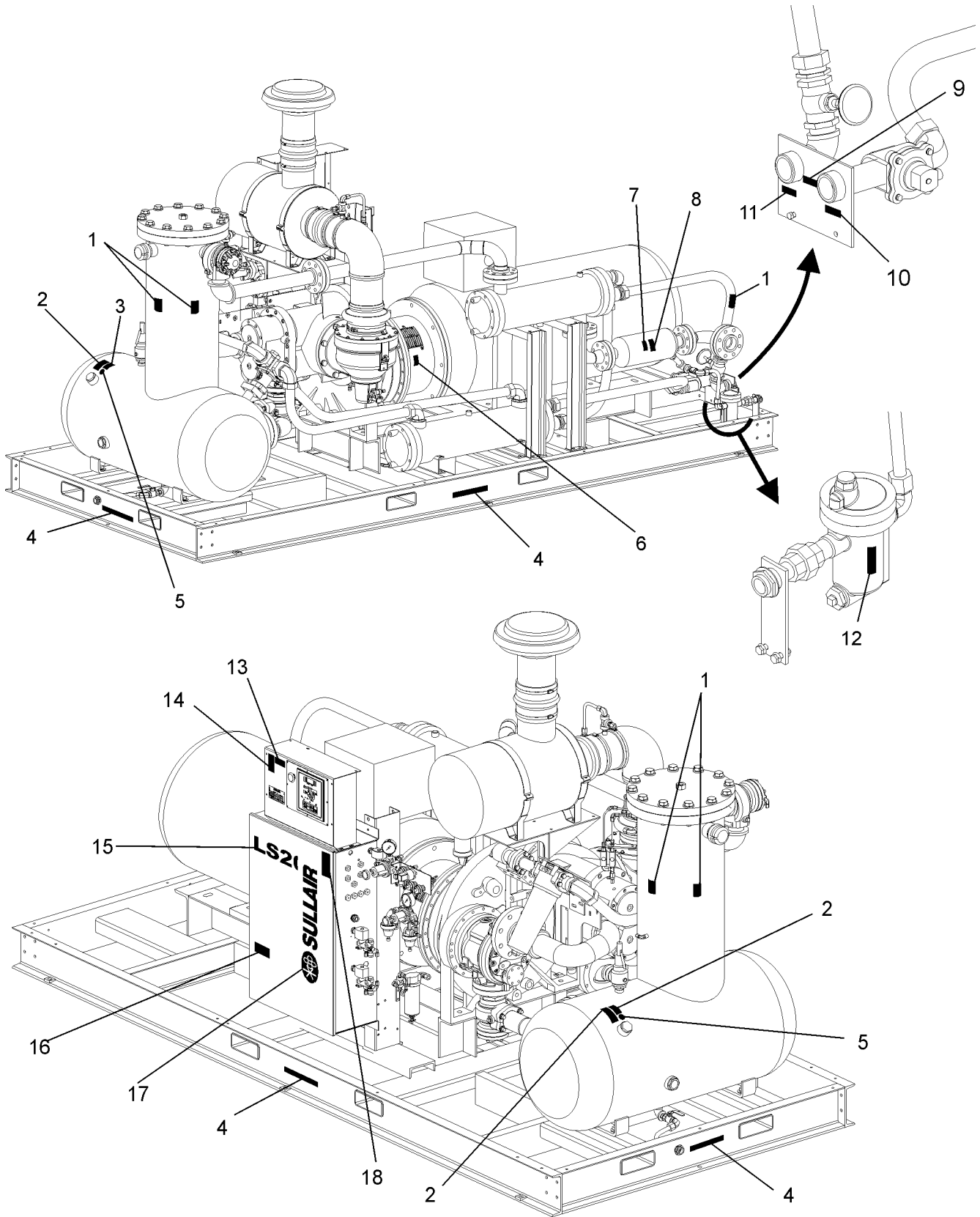

Section 8 ILLUSTRATIONS AND PARTS LIST

8.14 DECAL LOCATIONS- OPEN WATER-COOLED

<i>key number</i>	<i>description</i>	<i>part number</i>	<i>quantity</i>
1	sign, warning hot surfaces	407408	4
2	sign, warning "compressor fluid fill cap"	049685	1
3	decal, warning mixing fluids	02250110-891	1
4	decal, fork lifting	241814	4
5	decal, fluid Sullube	02250069-389	1
6	sign, warning sever-fan port	049965	2
7	sign, air breathing (danger)	250027-935	1
8	sign, warning "food grade" lube	250003-144	1
9	decal, water inlet-outlet	049873	1
10	decal, water out	250019-108	1
11	decal, water in	250019-107	1
12	decal, water drain	250022-810	1
13	decal, autostart	041065	1
14	decal, warning auto start	250017-903	1
15	decal, LS20T black 4" ht.	02250071-287	1
16	decal, ISO 9001	02250057-624	1
17	decal, Sullair logo 4 x 32" black	02250059-060	1
18	sign, warning sever - fan	049855	2

PLEASE NOTE: WHEN ORDERING PARTS, INDICATE THE SERIAL NUMBER OF COMPRESSOR

Section 8 ILLUSTRATIONS AND PARTS LIST

8.15 DECAL LOCATIONS- CONTROL BOX

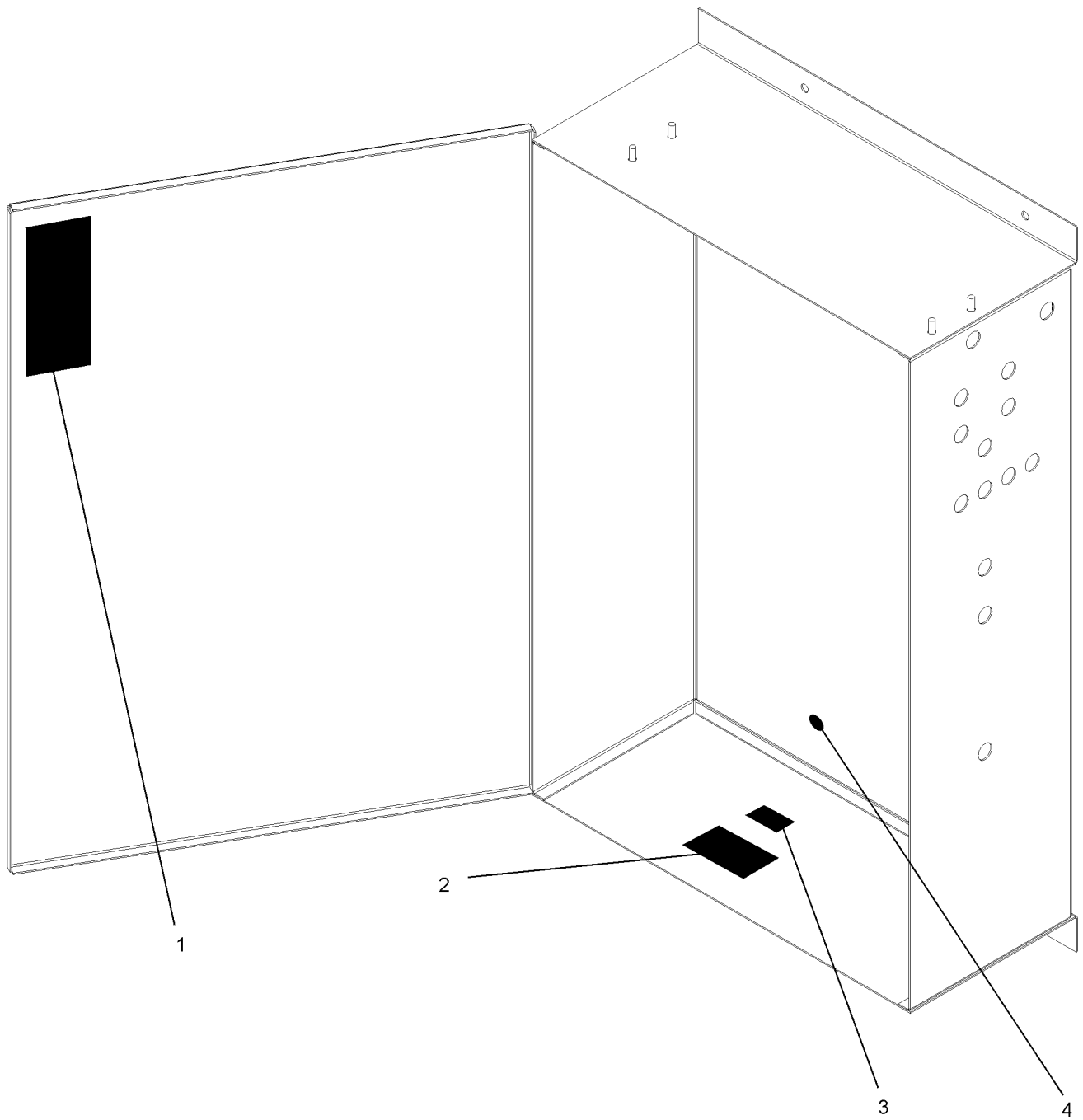

Section 8 ILLUSTRATIONS AND PARTS LIST

8.15 DECAL LOCATIONS- CONTROL BOX

<i>key number</i>	<i>description</i>	<i>part number</i>	<i>quantity</i>
1	sign, warning ground fault	049852	1
2	decal, danger high voltage	042218	1
3	decal, V 460/3/60 international (I)	02250069-399	1
4	decal, earth ground	02250075-046	1

(I) Due to custom voltage requests, voltage decal may vary. For positive identification of machine voltage decal, consult Sullair Factory with serial number of compressor.

PLEASE NOTE: WHEN ORDERING PARTS, INDICATE THE SERIAL NUMBER OF COMPRESSOR

NOTES

WORLDWIDE SALES AND SERVICE

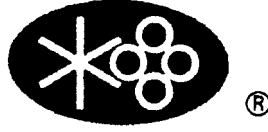

SULLAIR ASIA, LTD.

Sullair Road, No. 1
Chiwan, Shekou
Shenzhen, Guangdong PRV.
PRC POST CODE 518068
Telephone: 755-6851686
Fax: 755-6853473
www.sullair-asia.com

SULLAIR EUROPE, S.A.

Zone Des Granges BP 82
42602 Montbrison Cedex, France
Telephone: 33-477968470
Fax: 33-477968499
www.sullaireurope.com

SULLAIR CORPORATION

3700 East Michigan Boulevard
Michigan City, Indiana 46360 U.S.A.

www.sullair.com

Telephone: 1-800-SULLAIR (U.S.A. Only)
or 1-219-879-5451
Fax: (219) 874-1273

PARTS DEPARTMENT

Fax: (219) 874-1835
www.sullair.com/parts.shtm

SERVICE DEPARTMENT

Fax: (219) 874-1205
www.sullaircompressors.com



Printed in the U.S.A.

Specifications Subject To
Change Without Prior Notice
E03