

Vortex Flowmeter FV4000-VT4/VR4 Swirl Flowmeter FS4000-ST4/SR4

IndustrialIT
enabled™



HART[®]
FIELD COMMUNICATIONS PROTOCOL

ABB

Instrument Designation
FV4000-VT4/VR4
FS4000-ST4/SR4

Operating Instruction

Part No. D184B097U02

Issue date: 03.04
Revision: 02

Manufacturer:

ABB Automation Products GmbH
Dransfelder Str. 2
37079 Göttingen, Germany

Telephone: +49 (0) 55 19 05- 0
Telefax: +49 (0) 55 19 05- 777

© Copyright 2004 by ABB Automation Products GmbH
We reserve the right to technical amendments.

This document is protected by copyright. Information in this document is intended only to assist the user in the safe and efficient operation of the equipment. Its contents are not to be reproduced in full or part without prior approval of the legal owner.

1	Basic Safety Information	5
1.1	Safety Standards for this Instrument	5
1.2	Regulated Usage	5
1.3	Specification Limits	6
1.4	Allowable Fluids	6
1.5	Safety Marks, Symbols, Type and Factory Tags and CE-Identification	6
1.6	Factory Tag Specifications	7
1.7	Qualification of the Personnel	7
1.8	Responsibilities of the Operator	7
1.9	Possible Dangers When Transporting the Instruments	7
1.10	Possible Dangers During Installation	8
1.11	Possible Dangers During Electrical Installation	8
1.12	Possible Dangers During Installation in Explosion Hazardous Areas	8
1.13	Possible Dangers During Normal Operation	8
1.14	Possible Dangers During Inspection and Maintenance	8
1.15	Returns	9
2	Overview and Designs	10
3	Swirl Flowmeter FS4000-ST4/-SR4	11
3.1	Description of Function	11
3.2	Assembly and Installation of the Flowmeter Primary	13
3.2.1	Inspection	13
3.2.2	Installation of the Flowmeter Primary in the Pipeline	13
3.2.2.1	Installation Requirements	13
3.2.2.2	Recommended In- and Outlet Straight Sections	14
3.2.2.3	Relationship Between Fluid and Ambient Temperatures	14
3.2.2.4	Insulating the Swirl Flowmeter	15
3.2.2.5	Pressure and Temperature Measurements	15
3.2.2.6	Orientation of the Converter	16
4	Vortex Flowmeter FV4000-VT4/-VR4	17
4.1	Description of Functions	17
4.2	Assembly and Installation Flowmeter Primary	19
4.2.1	Inspection	19
4.2.2	Installation of the Flowmeter Primary in the Pipeline	19
4.2.2.1	Installation Requirements	19
4.2.2.2	Installation of Control Devices	20
4.2.2.3	Relationship Between Fluid and Ambient Temperatures	20
4.2.2.4	Insulating the Vortex Flowmeter	21
4.2.2.5	Centering the Wafer Design	21
4.2.2.6	Pressure and Temperature Measurements	22
4.2.2.7	Orientation of the Converter	22
5	Material Loads	23
5.1	General	23
5.1.1	Process Connections	23
5.1.1.1	DIN-Flanges	23
5.1.1.2	ASME-Flanges	23
5.1.2	DIN-Wafer Design	24
5.1.2.1	ASME-Wafer Design	24
6	Electrical Interconnections	25
6.1	Interconnection Examples Supply Power	25
6.2	Interconnection Examples Contact Output	26
7	Communication, HART™-Protocol	27
8	Vortex-/Swirl Flowmeter FV4000-VR4/FS4000-SR4	28

9	Data Entry/Operation and Configuration	30
9.1	LC Display	30
9.2	Data Entry	30
9.3	Menu System - 3 Levels	31
9.4	Menu System	32
9.4.1	Turn Program Protection On and Off A	32
9.4.2	Parameter and Data Entry Overview	33
9.4.3	Configurations for Gas, Steam and Liquids	38
9.4.4	Configuration of the Converter for Start-up	39
9.5	Additional Configuration Information	40
9.5.1	Meter Size	40
9.5.2	Calibration K-Factor	40
9.5.3	Submenu Hardware Configuration (contact output, terminals 41/42)	41
9.5.4	Configuration of the Contact Output	41
9.6	Error Register	42
9.6.1	Mains Interrupt	42
9.7	Normal Factor	42
10	Specifications Ex-Design	43
10.1	Specifications Converter	45
10.1.1	Design EEx „ib“ / EEx „n“ for VT41/ST41 and VR41/SR41 (4-20 mA/HART)	45
10.1.2	Terminals 31/32 / Supply Power or Supply Current (see also Chapter 6.1)	46
10.1.3	Ex-Approval Specifications VT41/ST41 / VR41/SR41	46
10.1.4	Fluid Temperatures/Temperature Classes	47
10.1.5	Insulating the Flowmeter	48
10.1.6	Name plate	48
10.2	Design EEx „d“ / EEx „ib“ / EEx „n“ for VT42/ST42 and VR42/SR42 (4-20 mA/HART)	49
10.2.1	Terminals 31/32 Supply Power or Supply Current	50
10.2.2	Ex-Approval Specifications VT42/ST42 / VR42/SR42	50
10.2.3	Fluid Temperatures/Temperatures Classes	51
10.2.4	Insulating the Flowmeter	52
10.2.5	Name plate	52
10.2.6	Special Installation Instructions for the Flameproof EEx „d“ Design	52
10.2.6.1	Connections Using the Pressure Tight Cable Connector	53
10.3	Design FM-Approval	53
10.3.1	Terminals 31/32 Supply Power or Supply Current (see also Chapter 6.1)	53
10.3.2	Ex-Approval Specifications	55
10.3.3	Fluid Temperatures/Temperature Classes	55
10.3.4	Insulating the Flowmeter	56
10.3.5	Name plate	56
10.3.6	Special Installation Information for Connecting the Flameproof FM-Design	56
10.3.6.1	Opening the Flowmeter	56
11	Certificates	57
11.1	EC-Type Examination Certificate	57
11.2	EC-Certificate of Compliance	63

1 Basic Safety Information

1.1 Safety Standards for this Instrument

- This instrument complies with the safety requirements of the Pressure Equipment Directive and state of the art technology. It was tested and shipped from our factory in a safe operating condition. In order to maintain this condition during operation, the requirements listed in this Operating Instruction must be observed and followed.
- Please note in particular the start-up instructions for explosion proof instruments. These may be found in the Ex-Chapter of this Operating Instruction ("Specifications Ex-Design" Sec.10).
- The instrument satisfies the EMC-Requirements in EN61326/NAMUR NE21.
- When a power interruption occurs, all instrument parameters are stored in a FRAM (including the present totalizer values). After the power is restored, the instrument is ready for operation immediately.

1.2 Regulated Usage

This instrument is used for

- transporting and metering the flowrate of liquids, gases (including unstable gases) and steam
- measuring the actual volume flow at operating conditions
- measuring in mass or normal flow units at constant operating conditions (pressure, temperature)
- measuring saturated steam flow in mass units under varying temperature / pressure conditions when a temperature sensor (option) is installed in the instrument.

The regulated usages include:

- installation within the specification limits
- observing and following the information regarding allowable fluids
- observing and following the information in the Operating Instruction
- observing and following the information in the accompanying documentation (Specifications, Diagrams, Dimensions)

The following usages of the instrument are not permissible:

- operation as an elastic compensation member in the pipeline, e.g. to compensate for pipe misalignment, pipeline vibrations, pipeline expansions, etc.,
- use as a climbing support, e.g. for assembly purposes,
- use as a support for external loads , e.g. support for the pipeline, etc.,
- material removal by drilling into the housing or material addition by painting over the factory or type tags or adding parts by welding or soldering.
- repairs, modifications and expansions and the use of replacement parts is only permissible as described in the Operating Instruction. Extensive activities must be approved by us. Excepted are repairs made in locations authorized by ABB. For unauthorized activities we accept no liability.

The operation and maintenance requirements in this Operating Instruction must be observed.

For damage resulting from improper or non-regulated usage the manufacturer assumes no liability.

1.3 Specification Limits

The instrument is to be used exclusively within the limits specified on the factory and name plate and listed in the Operating Instruction. The following limits are to be observed:







- The allowable pressure (PS) and the allowable fluid temperature (TS) must be \leq than the pressure/temperature values listed in Chapter 5 of this Operating Instruction. The specifications on the factory/type tags are to be observed.
- The max. and min. operating temperatures listed in the instrument specifications should not be exceeded.
- The allowable ambient temperature listed in the instrument specifications should not be exceeded.
- The Protection Class is IP 67 per EN60529.

1.4 Allowable Fluids

- Only such fluids should be metered for which assurance is available, either based on the state of the technology or past experience by the user, that the required chemical and physical resistance of the materials of the fluid wetted parts (process connections, meter pipe, sensor, sensor gaskets) will not be adversely affected during the operating life of the instrument.
- Fluids with unknown characteristics may only be metered if the user initiates a regular and suitable procedure to assure the safe condition of the instrument.

1.5 Safety Marks, Symbols, Type and Factory Tags and CE-Identification

All safety marks, symbols and the factory and type tags should be maintained in a readable state and protected from damage or loss. Note the following generalized information:

	Warning!	Information indicating that a risk or danger exists which could result in serious or fatal injuries to personnel.
	Caution!	Information indicating that a dangerous or unsafe operation might occur which could result in injury to personnel or property damage.
	Attention!	Information indicating that a dangerous situation may exist. If it is not reported, the product or an item in its vicinity may be damaged.
	Important!	The symbol „Important“ indicates a user tip or other important information, which if ignored, could result in a loss of operating ease or adversely affect system functionality. (Not an indicator for a dangerous/damaging situation!) Example: „Completed C-Routines for these may be found on the Support Diskette.“
	Ex-Protection	This symbol identifies instruments with Ex-Protection. When installed in Ex-Areas the specifications in Chapter 10 „Specifications Ex design“ must be considered.
	CE-Mark	The CE-Mark identifies compliance of the instrument with the following guidelines and the satisfying of the basic safety requirements. The added code number provides information about the location of the certification agency which performed the evaluation using the quality assurance systems based on the applicable directives: <ul style="list-style-type: none"> – Compliance with the EMC-Regulation 89/336/EWG – Compliance with the Ex-Regulation 94/9/ EG (only for instruments with Ex-Protection) – Compliance with the Pressure Equipment Directive PED/DGRL) 97/23/EU Pressure equipment will not have a CE-Mark on the factory tag if: <ul style="list-style-type: none"> – the max. allow, pressure (PS) is less than 0.5 bar. – there are minimal pressure risks (meter sizes \leq DN 25 [1"]). Then a certification procedure is not required.

1.6 Factory Tag Specifications

The factory tag is located on the flowmeter primary. Based on the meter size of the pressure equipment (> DN 25 [1"] or ≤ DN 25 [1"]), two different factory tags are used to identify the instrument (see also Par. 3 Sect. 3 PED/DGRL 97/23/EU):

a) Pressure Equipment Sizes > DN 25 [1"]

The factory tag includes the following specifications:

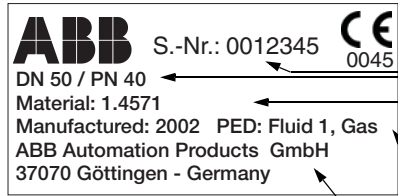

- CE-Mark (with number of the testing agency) to certify compliance of the instrument with the requirements of the PED/DGRL.
- Serial number provided by the manufacturer to identify the pressure equipment .
- Meter size and pressure rating the pressure equipment
- Materials of construction of the pressure equipment.
- Year of manufacture of the pressure equipment and specification of the Fluid Group per PED/DGRL (**P**ressure **E**quipment **D**irective) Fluid Group 1 = hazardous fluids, gaseous
- Manufacturer of the pressure equipment

b) Pressure Equipment Sizes ≤ DN 25 [1"]

The factory tag includes essentially the same specifications as the one described in a) with the following exceptions:



- There is no CE-Mark for the pressure equipment per Par. 3 Sect. 3 of the PED/DGRL.
- In PED the basis for the exception is given in Par. 3 Sect. 3 of the PED. The pressure equipment is categorized under the section SEP (=Sound Engineering Practice).

1.7 Qualification of the Personnel

The electrical installation, start-up and maintenance of the instrument should only be carried out by trained personnel authorized by the system operator. The personnel must read and understand the Operating Instruction and follow its instructions.

1.8 Responsibilities of the Operator

- When metering corrosive or abrasive fluids the operator must evaluate the resistance of the fluid wetted parts. The fluid wetted parts are the meter pipe, shedder (only Vortex flowmeters FV4000-VR4, FV4000-VT4), in- and outlet guide bodies (only Swirl flowmeters FS4000-SR4, FS4000-ST4), sensor and the gaskets. ABB will gladly provide assistance in their selection, but cannot assume any liability.
- Observe the national standards in your country applicable to testing the function, repair and maintenance of electrical instruments.

1.9 Possible Dangers When Transporting the Instruments

Note when transporting the instrument (especially instruments heavier than 50 kg) to the installation site that:

- the center of gravity may be off-center.
- existence of possible impact points and
- transport protection devices (e.g. caps over openings).

1.10 Possible Dangers During Installation

Before installing assure that:

- the flow direction corresponds with the arrow on the instrument.
- the instrument is installed in a stress free manner (parallel mating flanges) and that gaskets suitable for the operating conditions are used.
- the required lengths of the in- and outlet straight sections are provided.
- the pipeline is supported at both ends of the instrument.

1.11 Possible Dangers During Electrical Installation

- The electrical installation is to be completed only by authorized trained personnel in accordance with the Interconnection Diagrams.
- Especially observe the information regarding the electrical connections in this Operating Instruction, otherwise the electrical protection type may be adversely affected.
- Ground the flowmeter system.



Attention!

When the housing cover is removed the EMC- and personnel protection are no longer provided. Observe the special instructions for explosion protected instruments in the Ex-Chapter.

1.12 Possible Dangers During Installation in Explosion Hazardous Areas

In Ex-Areas special requirements apply for connecting the supply power and the contact output. Follow the specifications in the Ex-Chapter.

1.13 Possible Dangers During Normal Operation

- When metering abrasive fluids or if cavitation occurs, damage to the pressure containing parts may occur.
- When metering hot fluids, touching the flowmeter primary surface could cause burns.
- Aggressive fluids can lead to corrosion and abrasion. Pressurized fluids could possibly leak.

1.14 Possible Dangers During Inspection and Maintenance

- Before performing any operations on the instrument (removal/opening of the pressure tap in the Swirl flowmeter) assure that the instrument and the adjacent piping or tanks have been depressurized.



Warning!

The pressure tap in the Swirl flowmeter is under pressure. Exiting fluid could produce serious injury. Make certain that the pipeline is depressurized before opening the pressure tap.

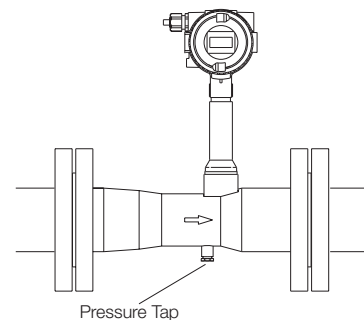



Attention!

Never loosen the mounting screws of the pedestal.
 Never remove the converter from the pedestal.
 The instrument could be destroyed.
 If problems exist, contact ABB-Service

- Before removing the instrument, check if the instrument was used to meter dangerous fluids. It may be possible that hazardous residues may still be present in the instrument which could exit when the meter is uninstalled.
- We recommend when pipeline vibrations exist to secure the flange bolts and nuts against loosening.
- Within the framework of user responsibilities, perform a regular inspection of the instrument including:
 - its functionality
 - the seals
 - any abrasion or wear (corrosion, abrasion, cavitation)

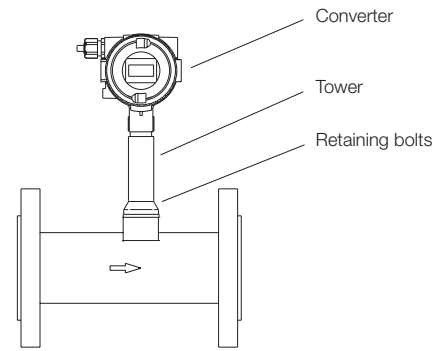

1.15 Returns

If it is necessary to return the instrument for repair or recalibration to the ABB factory in Göttingen, Germany, use the original packaging material or a suitably protective packing material. Please indicate the reason for the return.



Important! EU-Hazardous Material Directives

state that the owner of special wastes is responsible for its decontamination and must satisfy the following requirements before shipping the materials:

- All flowmeter primaries and/or flowmeter converters which are returned to ABB for repair are to be free of any hazardous materials (acids, bases, solvents, etc.). This includes flushing and decontaminating the hazardous materials which may be present in the cavities in the primaries between the meter tube and the housing. Written confirmation that these measures have been carried out should accompany the flowmeter.
- If the user cannot completely remove the hazardous materials, then appropriate documents should accompany the shipment acknowledging this condition. Any costs incurred by ABB to remove and decontaminate the hazardous materials during the repair will be billed to the owner of the instrument.



Important!

This Operating Instruction contains instructions relative to the start-up and testing of the instrument as well as specifications for the instrument designs. The rights to make revisions to the hardware and/or software which improve the technology are reserved by the manufacturer. Information regarding the present stand and possible further improvements may be obtained from our factory in Göttingen, Germany or from your local ABB-Sales Bureau.

2 Overview and Designs

This Operating Instruction is subdivided into the following chapters:

An introductory safety chapter, three chapters with information relating to the operation and installation of the FV4000 and FS4000, five chapters describing the electrical interconnections and configuration and a special chapter for the Ex-Design. The specifications may be found in the separate Data sheet document D184S035U02.

Basically there are two designs:

a) Compact Design:

Converter is mounted directly on the flowmeter primary.

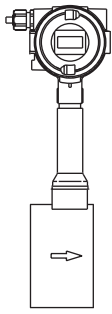
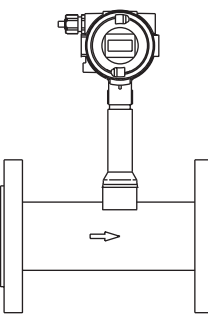
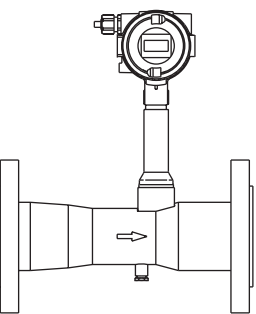
		
<p>Vortex Flowmeter FV4000-VT4 Wafer Design</p>	<p>Vortex Flowmeter FV4000-VT4 Flanged Design</p>	<p>Swirl Flowmeter FS4000-ST4 Flanged Design</p>

b) Remote Design:

The converter can be installed up to 10m distant from the flowmeter primary.

The cable is permanently attached to the converter. It can be shortened if required.

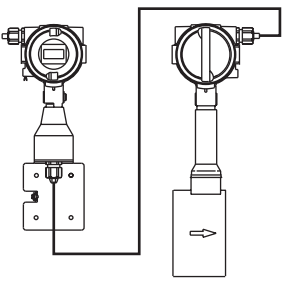
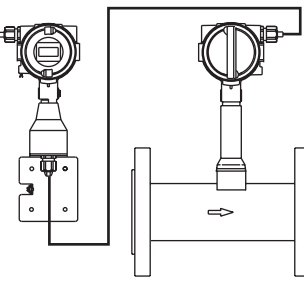
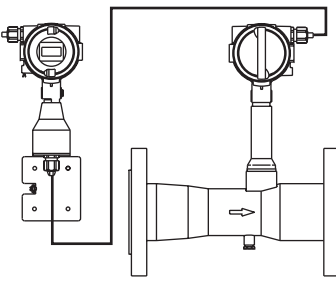
		
<p>Vortex Flowmeter FV4000-VR4 Wafer Design</p>	<p>Vortex Flowmeter FV4000-VR4 Flanged Design</p>	<p>Swirl Flowmeter FS4000-SR4 Flanged Design</p>

3 Swirl Flowmeter FS4000-ST4/SR4

3.1 Description of Function

With the Swirl Flowmeter (FS4000) the flowrate of gases, steam and liquids can be metered over a wide range independent of the fluid properties.

The Swirl Flowmeter contains no moving parts and is therefore maintenance and wear free.

Principle of Operation

The inlet guide body forces the axially entering fluid flow stream to rotate. A vortex core forms in the center of this rotation in which a secondary rotation is generated due to the backflow (see Fig. 1 and Fig. 2).

The frequency of this secondary rotation is proportional to the flowrate and is linear over a wide flow range when the internal geometry of the flowmeter has been optimized. This frequency is measured with a Piezo sensor. The flowrate proportional frequency signal from the flowmeter primary is processed and conditioned in the converter.

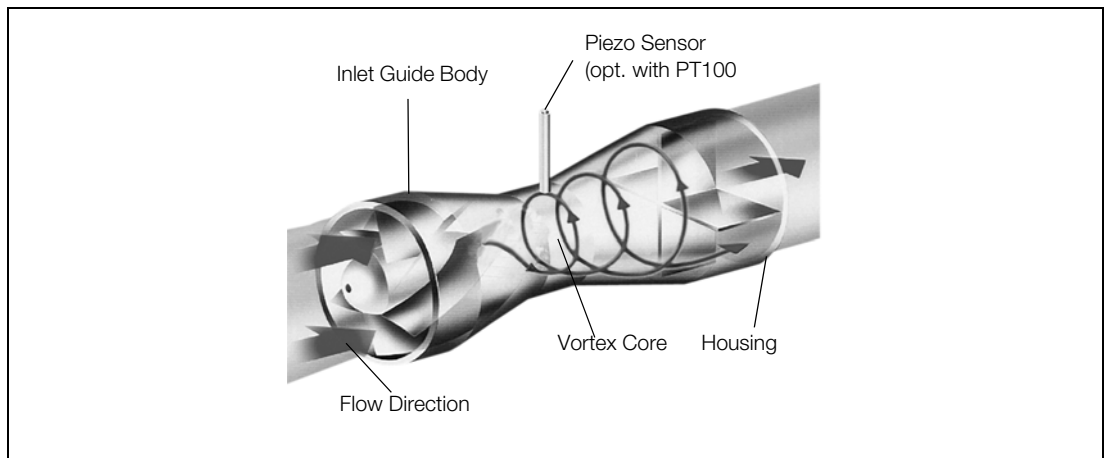

Fig. 1: Principle of Operation FS4000-ST4/SR4

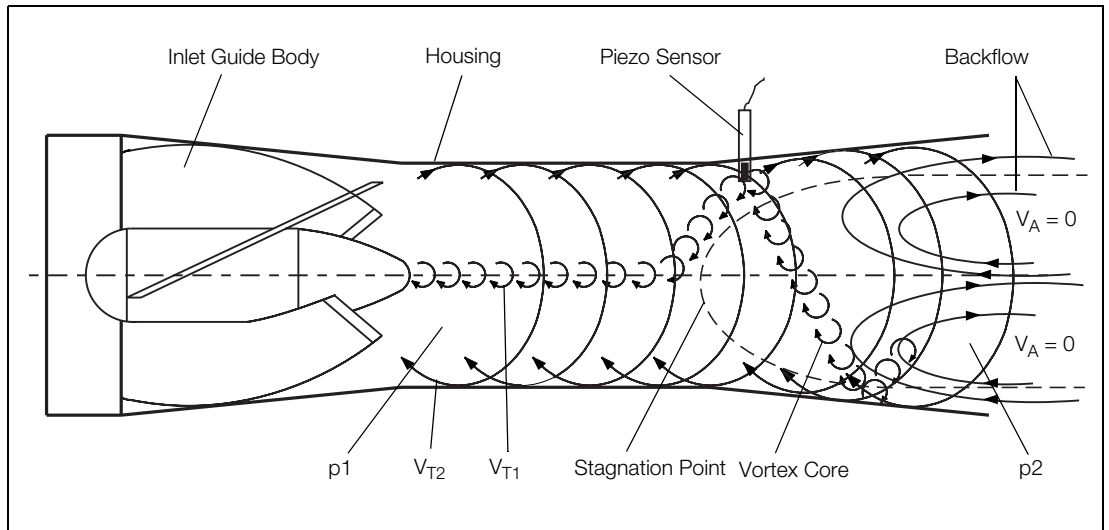

Fig. 2: Principle of Operation Schematic Swirl Flowmeter

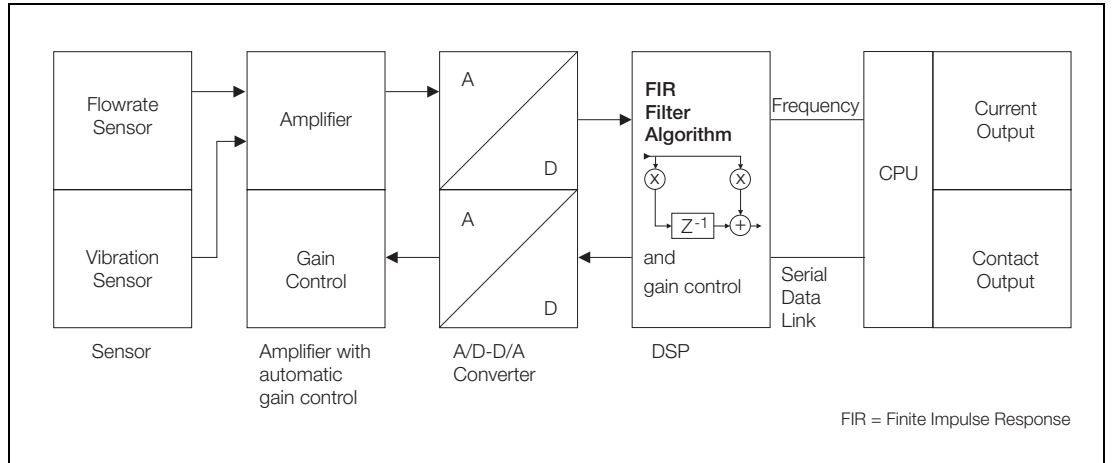

Fig. 3: Function Diagram Converter

Both the flowrate and the vibration piezo sensors generate signals which are amplified and fed to the analog/digital converter. The input of an gain control in the DSP provides a signal over the D/A-converter used by the gain control to dynamically set the required amplification. The filter algorithm in the DSP evaluates the signal and uses the flow signal and transmits this frequency to the CPU for conversion to flowrate information. This data is then indicated in the display and transmitted over the current and contact outputs or over a Fieldbus data link.

3.2 Assembly and Installation of the Flowmeter Primary

3.2.1 Inspection

Before installing the Swirl Flowmeter check for mechanical damage due to improper handling during shipment. All claims for damages are to be made promptly to the shipper prior to installation.

3.2.2 Installation of the Flowmeter Primary in the Pipeline

3.2.2.1 Installation Requirements

The Swirl Flowmeter can be installed at any arbitrary location in the pipeline. Care should be exercised to assure that

- the ambient specifications are not exceeded (see Data Sheet D184S035U02).
- the recommended lengths of the in- and outlet straight sections are maintained (Fig. 5).
- the flow direction corresponds to the direction indicated by the arrow on the flowmeter primary.
- the required distance for removing the converter and to exchange the sensors is available (see Data Sheet D184S035U02).
- mechanical vibrations of the pipeline should be damped through use of supports as required.
- the inside diameter of the flowmeter primary and the pipeline should be the same.
- pressure fluctuations in long pipelines at zero flow should be eliminated by installing intermediate shutoff valves.
- pulsating flow from piston pumps or compressors should be reduced using appropriate damping devices. The remaining pulsation should not exceed 10 %. The frequency of the flow producers should not be in the same range as the measurement frequency of the flowmeter.
- valves/gates should generally be installed downstream from the flowmeter (typ. 3 x D). When piston pumps or compressors are used to produce the flow (pressure for liquids > 10 bar) it may be possible that water hammer could occur in the pipeline when the valve is closed. In such situations it is essential that valves be installed upstream of the flowmeter or suitable damping devices be utilized.
- when metering liquids the flowmeter must always be completely filled with fluid and should not drain.
- when metering liquids or steam cavitation may not occur.
- **for high temperatures (>150 °C), the flowmeter primary should be installed so that the electronic module is to the side or below the flowmeter (Fig. 4).**

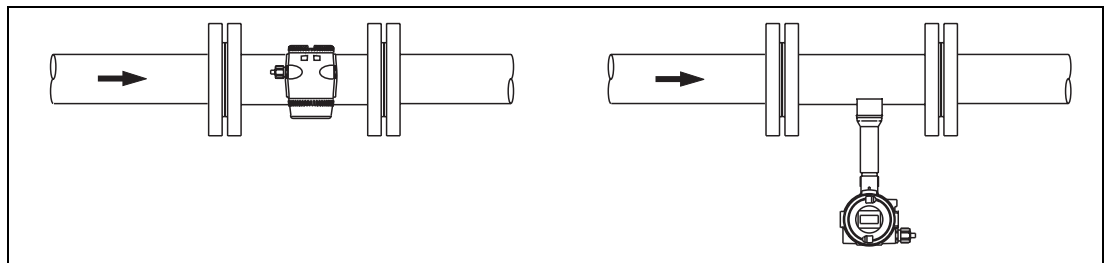

Fig. 4: Installation for High Fluid Temperatures >150 °C

3.2.2.2 Recommended In- and Outlet Straight Sections

Based on its metering principle the Swirl Flowmeter in essence does not require any straight in- or outlet sections. Fig. 5 shows the recommended in- and outlet sections for various installation conditions. Additional in- and outlet sections are not required for single and double elbows installed up- or downstream from the flowmeter, when their radius is greater than $1.8 \times D$, nor are additional in- and outlet sections required when the flowmeter is installed downstream from a flanged reducer per DIN 28545 ($a/2=8^\circ$).

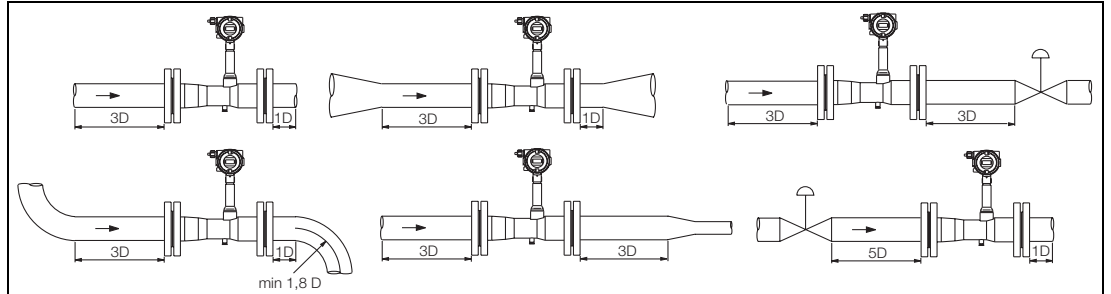

Fig. 5: Recommended In- and Outlet Straight Sections

3.2.2.3 Relationship Between Fluid and Ambient Temperatures

The relationship between the fluid and ambient temperatures must be considered (Fig. 6).

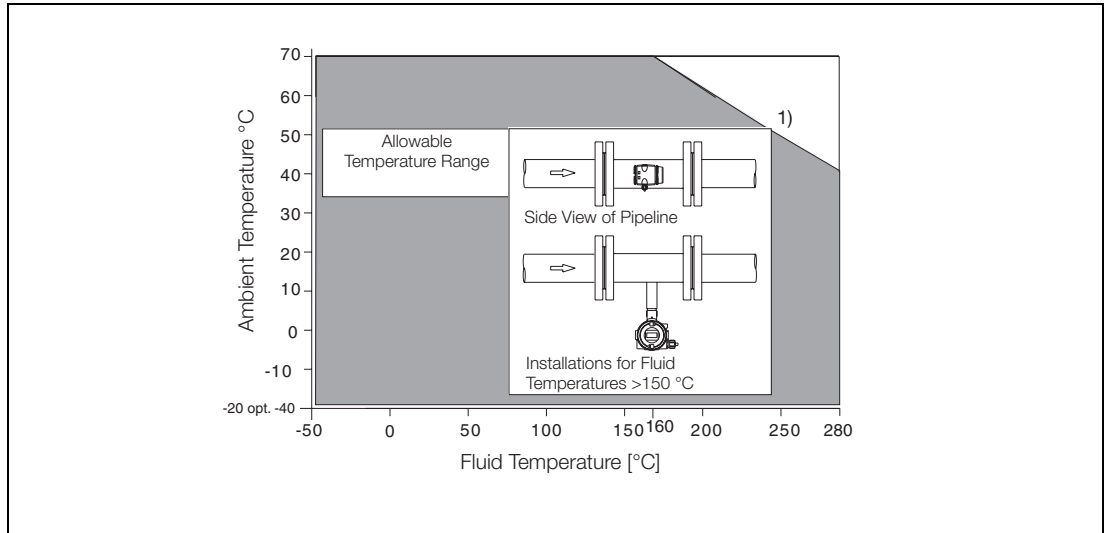

Fig. 6: Relationship Ambient and Fluid Temperatures

- 1) Cables suitable for temperatures to $T= 110^\circ\text{C}$ may be used for the supply power, terminals 31, 32 and the contact output 41, 42 without restrictions. Cables only suitable for temperatures to $T= 80^\circ\text{C}$, reduce the allowable temperature ranges.



Important!

For temperatures $< 0^\circ\text{C}$ and $> 55^\circ\text{C}$ limitations may apply due to the lack of readability of the display. The functionality of the flowmeter and the outputs are unaffected.

3.2.2.4 Insulating the Swirl Flowmeter

The pipeline can be insulated to a thickness not exceeding 100 mm above its upper surface (see Fig. 7) .

Installation of Trace Heaters

Trace heaters may be installed if:

- they are rigidly mounted close to or around the pipeline
- they are embedded in the pipeline insulation, if used (max. thickness of 100 mm must be maintained).
- the max. resultant temperature of the trace heaters \leq the max. fluid temperature.

The Installation Regulations are to be Maintained!

Assure that the installation of trace heaters does not have any adverse effect on the EMC-Protection, and does not add any additional vibrations.

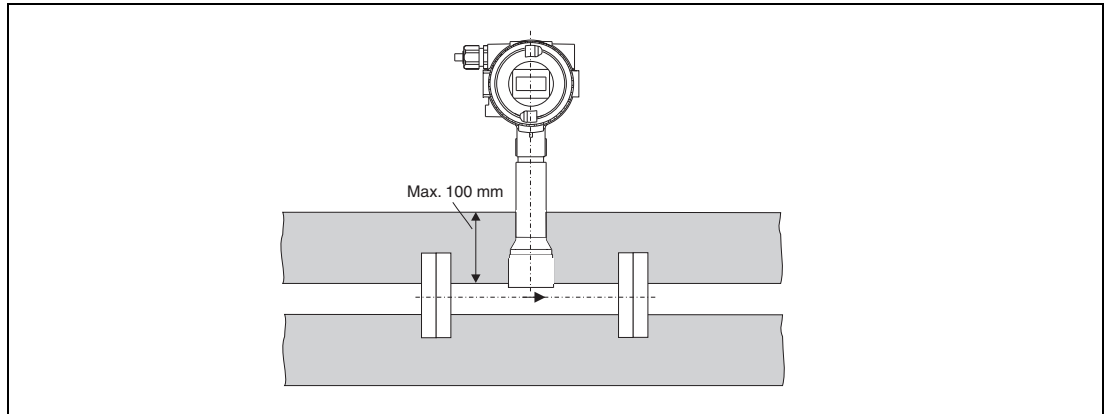

Fig. 7: Flowmeter Insulation

3.2.2.5 Pressure and Temperature Measurements

As an option, a PT100 temperature sensor can be installed in the Swirl Flowmeter for direct temperature measurements. This temperature measurement can be used to monitor the fluid temperature or for the direct measurement of saturated steam in mass units.

If a pressure and temperature compensation is to be made externally (e.g. using Sensycal) then the temperature sensor should be installed as shown in Fig. 8. The pressure tap on the flowmeter primary must be used for the pressure measurement.

At primaries w/o pressure tag the pressure and temperature measurement is made downstream from the flowmeter primary. See page 22, Fig. 19.

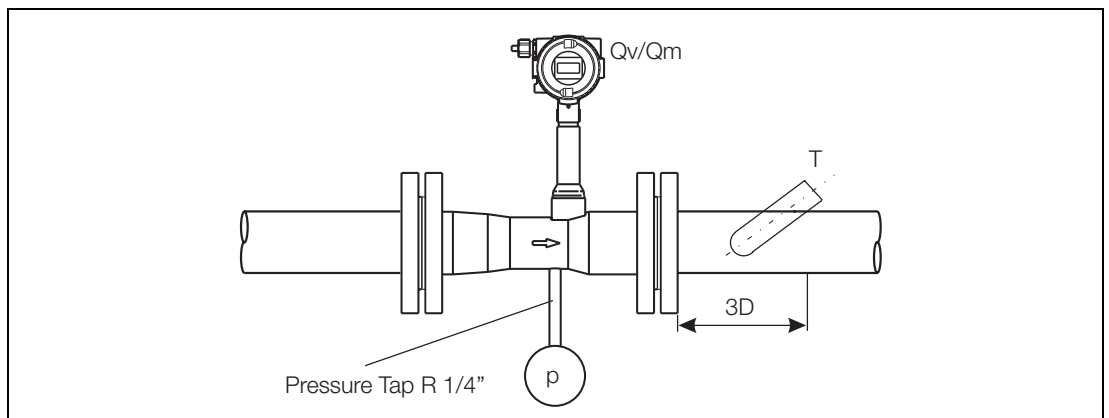

Fig. 8: Installation of Pressure and Temperature Measurement Elements

3.2.2.6 Orientation of the Converter

The housing for the electronic module can be rotated during installation to a preferred orientation. A mechanical stop is incorporated in the housing to prevent a rotation of more than 330°. This is to protect the cable exiting from the flowmeter primary from damage.

1. Loosen the locking screw in the housing for the electronic module using a 4 mm Allen head wrench.
2. Press out the bolts.
3. Rotate the housing for the electronic module in the desired direction.
4. Reinsert the bolts.
5. Tighten the locking screw.

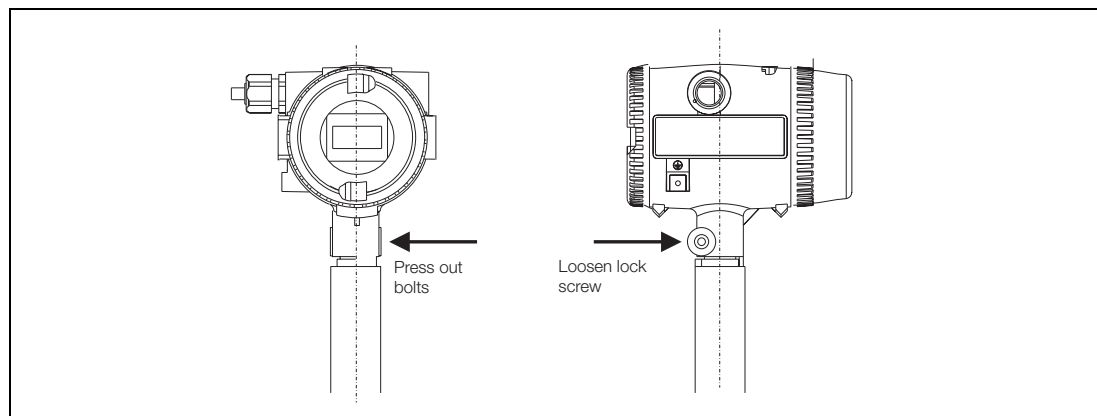

Fig. 9: Rotating the Housing for the Electronic

4 Vortex Flowmeter FV4000-VT4/-VR4

4.1 Description of Functions

With the Vortex Flowmeter the flowrate of gases, steam and liquids can be metered over a wide range independent of the fluid properties.

Principle of Operation

The operation of the Vortex Flowmeter is based on the Karman Vortex Street. As the flow passes by an obstructing body (shedder) vortices are alternately formed on either side. The flow causes these vortices to shed forming a vortex street (Karman Vortex Street) (Fig. 10).

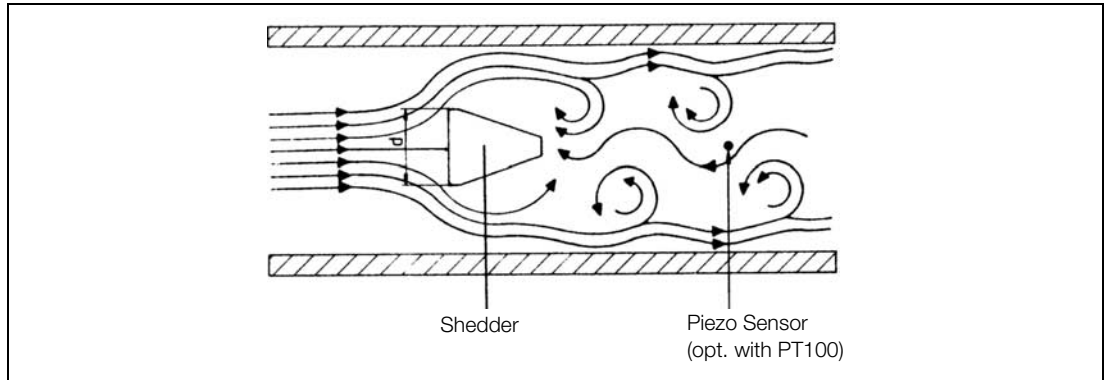

Fig. 10: Karman Vortex Street

The frequency f of the vortex shedding is proportional to the flow velocity v and indirectly proportional to the width of the shedder d :

$$f = St \cdot \frac{v}{d}$$

St , the Strouhal-Number, is a dimensionless value which defines the quality of the vortex flow measurements. For properly designed shedders St is constant over wide Reynolds Number Re (Fig. 11).

- ν = Kinematic viscosity
- v = Flow velocity
- D = Inside diameter of the meter pipe

$$Re = \frac{v \cdot D}{\nu}$$

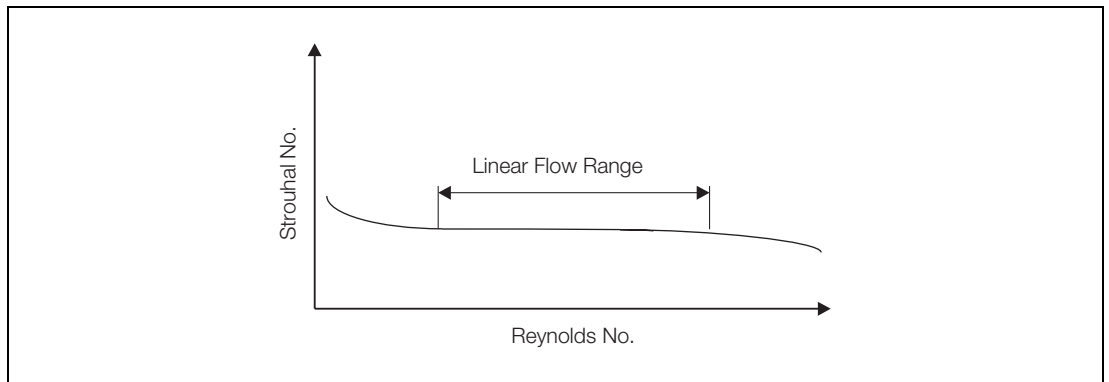

Fig. 11: Relationship Strouhal Number / Reynolds Number

The vortex frequency to be evaluated is a function only of the flow velocity and is independent of the density and viscosity of the fluid.

The local pressure changes associated with the vortex shedding are detected by a Piezo-Sensor and converted into electrical pulses corresponding to the shedding frequency. In the converter this frequency signal is processed and conditioned.

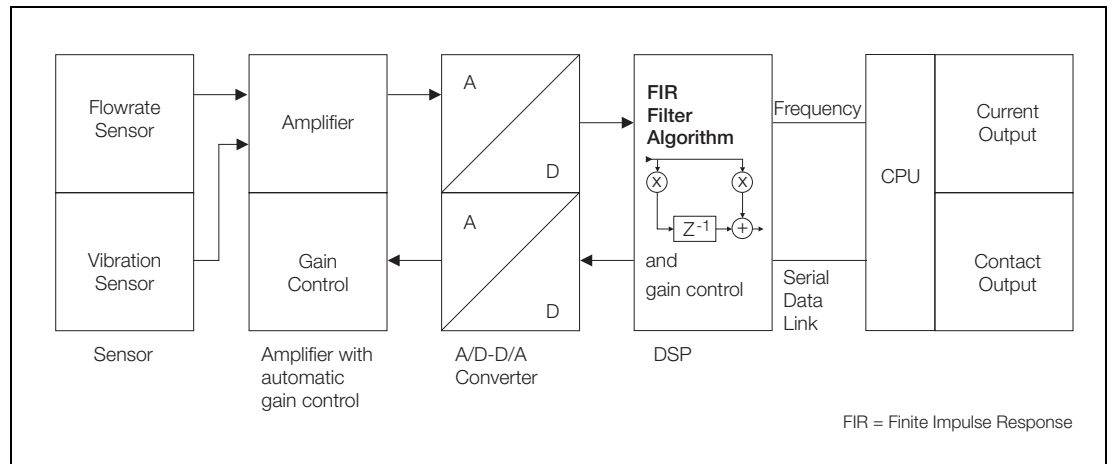

Fig. 12: Functional Diagram of the Converter

Both the flowrate and the vibration piezo sensors generate signals which are amplified and fed to the analog/digital converter. The input of an gain control in the DSP provides a signal over the D/A-converter used by the gain control to dynamically set the required amplification. The filter algorithm in the DSP evaluates the signal and uses the flow signal and transmits this frequency to the CPU for conversion to flowrate information. This data is then indicated in the display and transmitted over the current and contact outputs or over a Fieldbus data link.

4.2 Assembly and Installation Flowmeter Primary

4.2.1 Inspection

Before installing the Vortex Flowmeter check for mechanical damage due to improper handling during shipment. All claims for damages are to made promptly to the shipper prior to installation.

4.2.2 Installation of the Flowmeter Primary in the Pipeline

4.2.2.1 Installation Requirements

The Vortex Flowmeter can be installed at any arbitrary location in the pipeline. Care should be exercised to assure that:

- the ambient specifications are not exceeded (see Specifications D184S035U02).
- the recommended lengths of the in- and outlet straight sections are maintained (Fig. 13).
- the flow direction corresponds to the direction indicated by the arrow on the flowmeter primary.
- the required distance for removing the converter and to exchange the sensors is available (see Specifications D184S035U02).
- mechanical vibrations of the pipeline should be damped through use of supports as required.
- the inside diameter of the flowmeter primary and the pipeline should be the same.
- pressure fluctuations in long pipelines at zero flow should be eliminated by installing intermediate shutoff valves.
- pulsating flow from piston pumps or compressors should be reduced using appropriate damping devices. The remaining pulsation should not exceed 10 %. The frequency of the flow producers should not be in the same range as the measurement frequency of the flowmeter.
- valves/gates should generally be installed downstream from the flowmeter (typ. 5 x D). When piston pumps or compressors are used to produce the flow (pressure for liquids > 10 bar) it may be possible that the fluid vibrates in the pipeline when the valve is closed. In such situations it is essential that valves be installed upstream of the flowmeter or suitable damping devices be utilized.
- when metering liquids the flowmeter must always be completely filled with fluid and should not drain.
- when metering liquids or steam cavitation may not occur
- **for high temperatures (>150 °C), the flowmeter primary should be installed so that the electronic module is to the side or below the flowmeter (Fig. 15).**

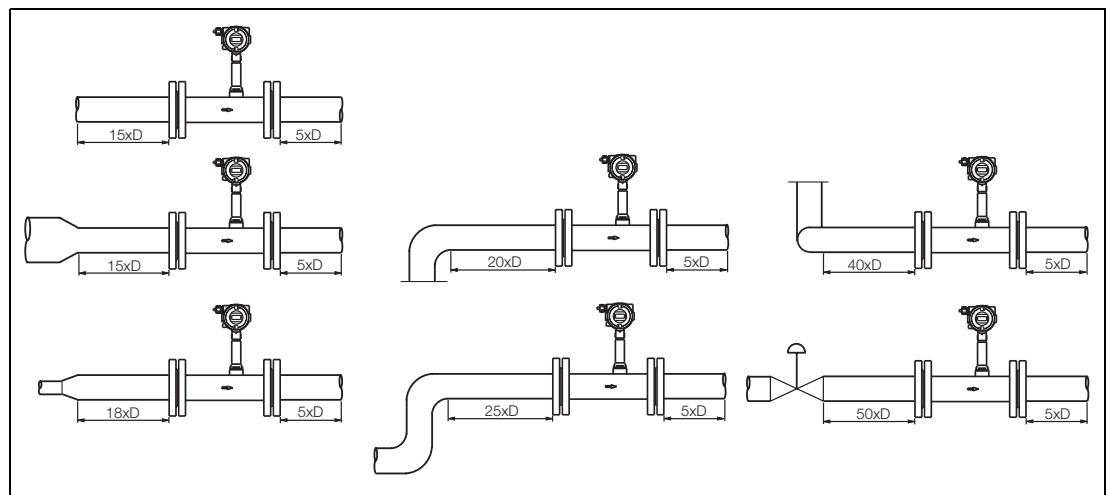

Fig. 13: Recommended In- and Outlet Straight Sections

4.2.2.2 Installation of Control Devices

Regulators and control devices should preferably be installed downstream from the flowmeter.

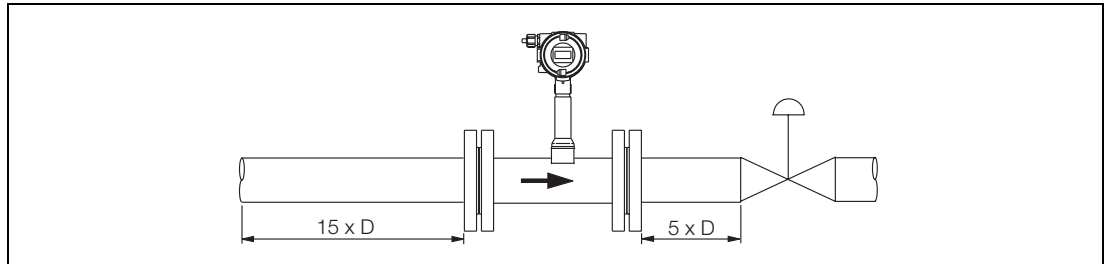

Fig. 14: Installation Control Devices

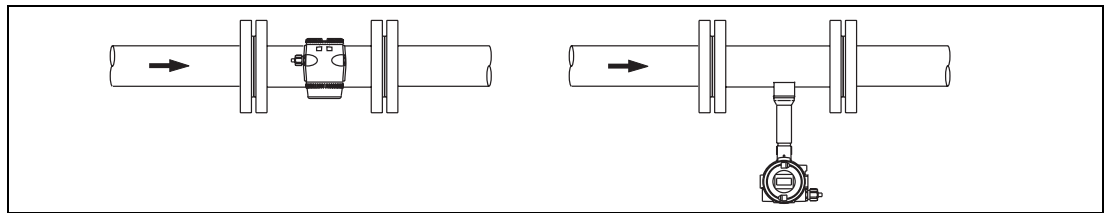

Fig. 15: Installation for High Fluid Temperatures >150 °C

4.2.2.3 Relationship Between Fluid and Ambient Temperatures

The relationship between the fluid and ambient temperatures must be considered account (Fig. 16).

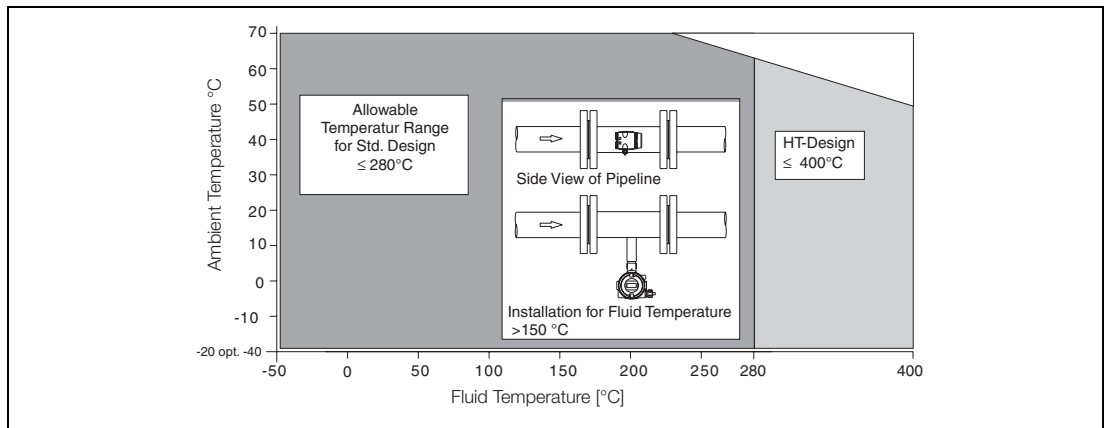

Fig. 16: Relationship Ambient and Fluid Temperatures

- 1) Cables suitable for temperatures to T= 110°C may be used for the supply power, terminals 31, 32 and the contact output 41, 42 without restrictions. Cables only suitable for temperatures to T= 80 °C , reduce the temperature ranges.



Important!

For temperatures < 0 °C and > 55 °C limitations may apply due to the lack of readability of the display. The functionality of the flowmeter and the outputs are unaffected.

4.2.2.4 Insulating the Vortex Flowmeter

The pipeline can be insulated to a thickness not exceeding 100 mm above its upper surface (see Fig. 17) .

Installation of Trace Heaters

Trace heaters may be installed if:

- they are rigidly mounted close to or around the pipeline
- they are embedded in the pipeline insulation, if used (max. thickness of 100 mm must be maintained).
- the max. resultant temperature of the trace heaters \leq the max. fluid temperature.

The Installation Regulations are to be Maintained!

Assure that the installation of trace heaters does not have any adverse effect on the EMC-Protection, and does not add any additional vibrations.

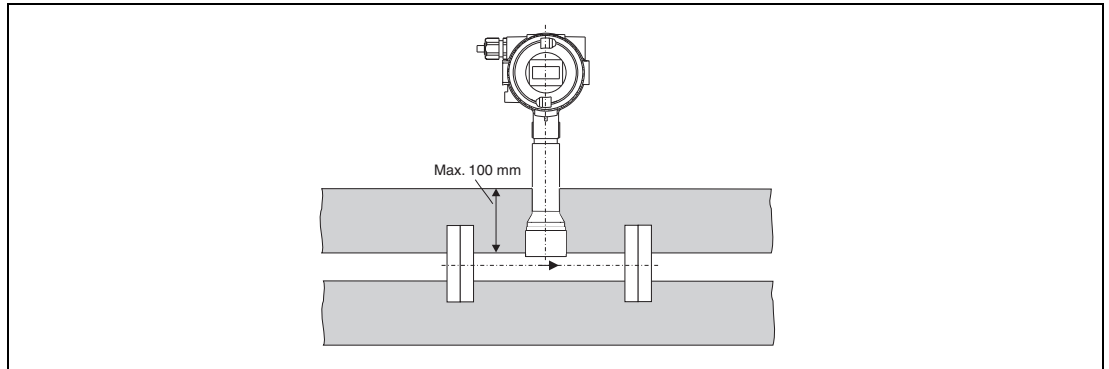

Fig. 17: Flowmeter Insulation

4.2.2.5 Centering the Wafer Design

The wafer design flowmeters are centered utilizing the outside diameter of the flowmeter primary body in conjunction with the mounting bolts. Centering rings or sleeves for the mounting bolts, whose dimensions are a function of the meter size and pressure rating, are included with the shipment as accessories (option).

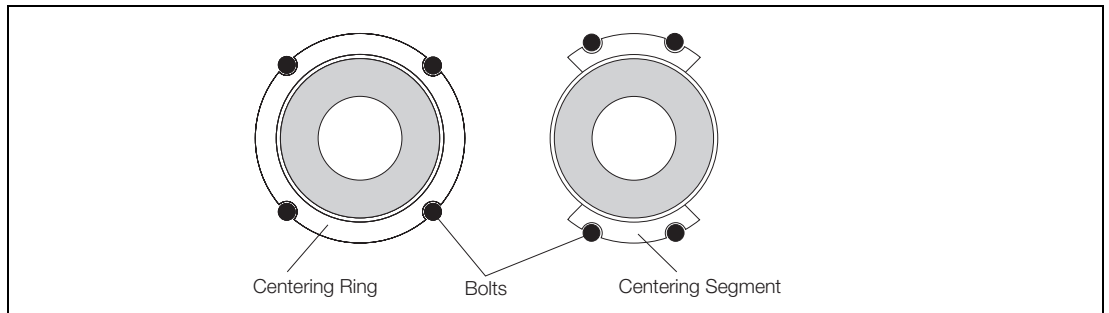

Fig. 18: Centering the Wafer Design Using Rings or Segments

4.2.2.6 Pressure and Temperature Measurements

As an option a PT100 temperature sensor can be installed in the Swirl Flowmeter for direct temperature measurements. This temperature measurement can be used to monitor the fluid temperature or for the direct measurement of saturated steam in mass units. If a pressure and temperature compensation is to be made externally (e.g. using Sensycal) then the measurement elements are to be installed as shown in Fig. 19.

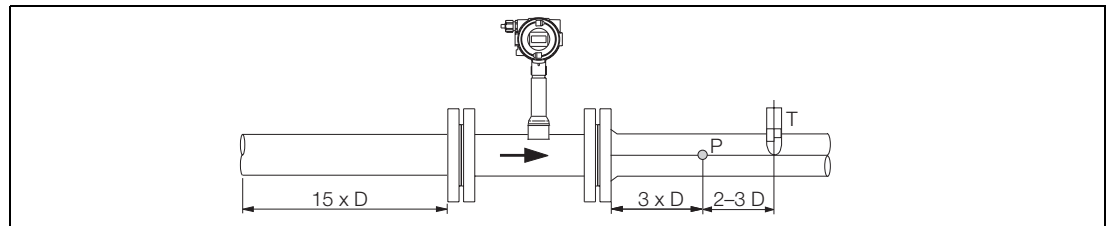

Fig. 19: Locations of Pressure and Temperature Measurements

4.2.2.7 Orientation of the Converter

The housing for the electronic module can be rotated during installation to the preferred orientation. A mechanical stop is incorporated in the housing to prevent a rotation of more than 330°. This is to protect the cable exiting from the flowmeter primary from damage.

1. Loosen the locking screw in the housing for the electronic module using a 4 mm Allen head wrench.
2. Press out the bolts.
3. Rotate the housing for the electronic module in the desired direction.
4. Reinsert the bolts.
5. Tighten the locking screw.

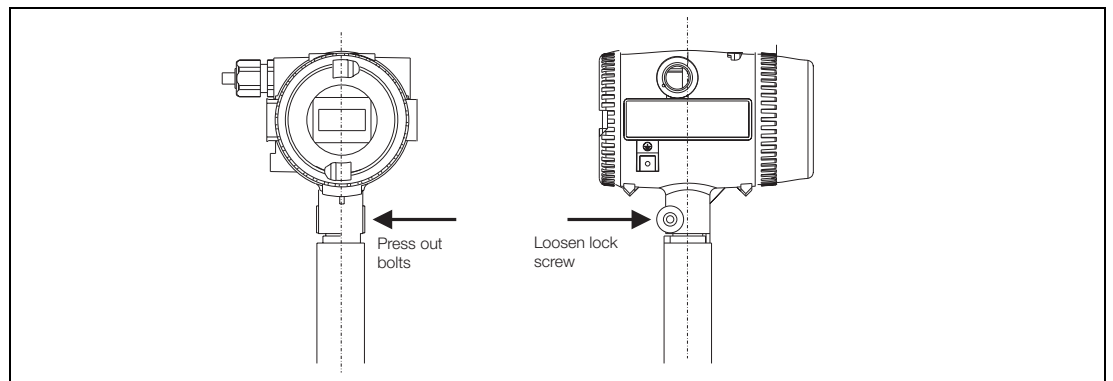

Fig. 20: Rotating the Housing for the Electronics

5 Material Loads

5.1 General



Attention!

Limitations of the allowable fluid temperature (TS) may result from the sensor gasket materials used. See factory and type tags of the instrument. Ignoring these restrictions may result in destruction of the gasket and the instrument.

5.1.1 Process Connections

5.1.1.1 DIN-Flanges

SS.1.4571 [316Ti]

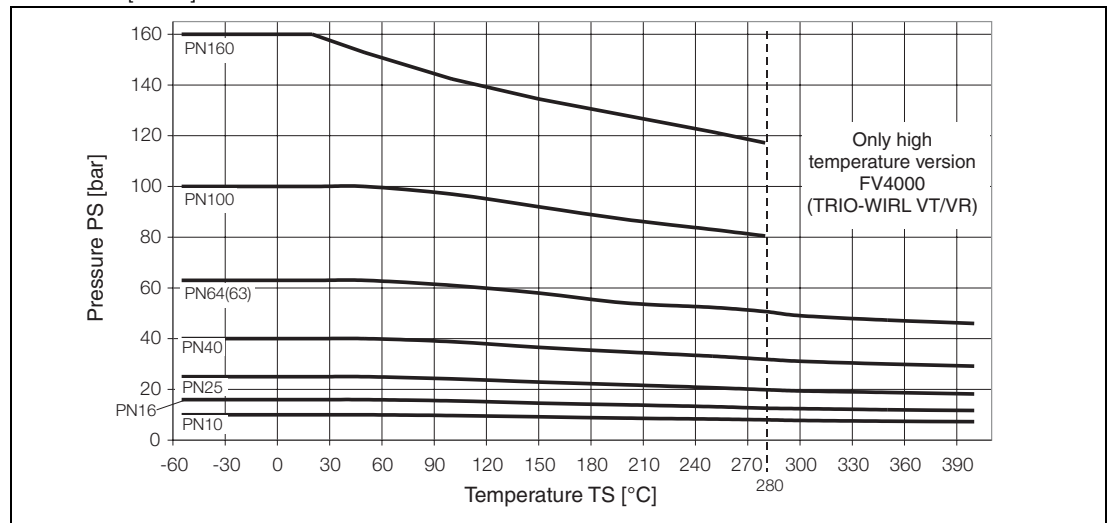

5.1.1.2 ASME-Flanges

SS.1.4571 [316Ti]

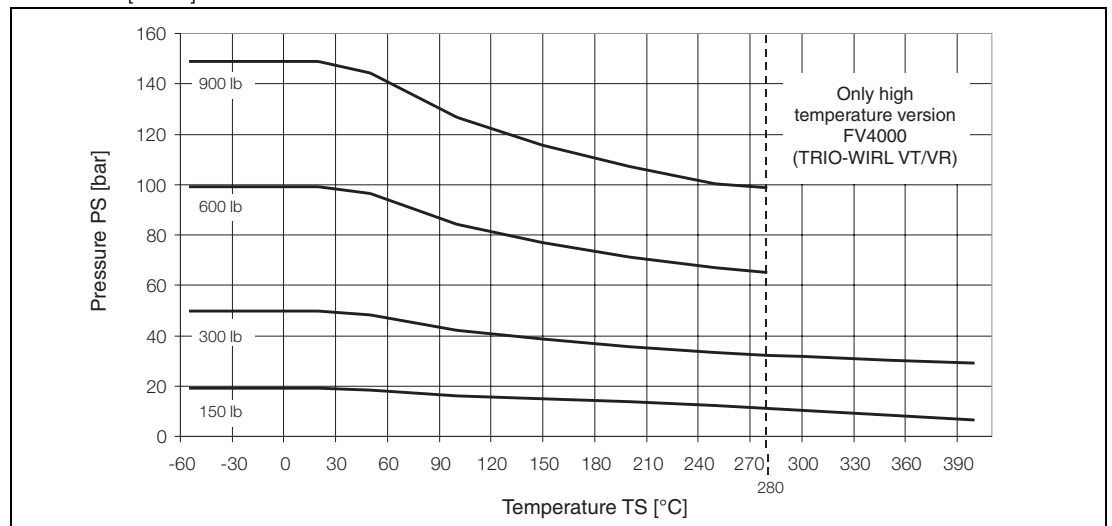

5.1.2 DIN-Wafer Design

SS.1.4571 [316Ti]

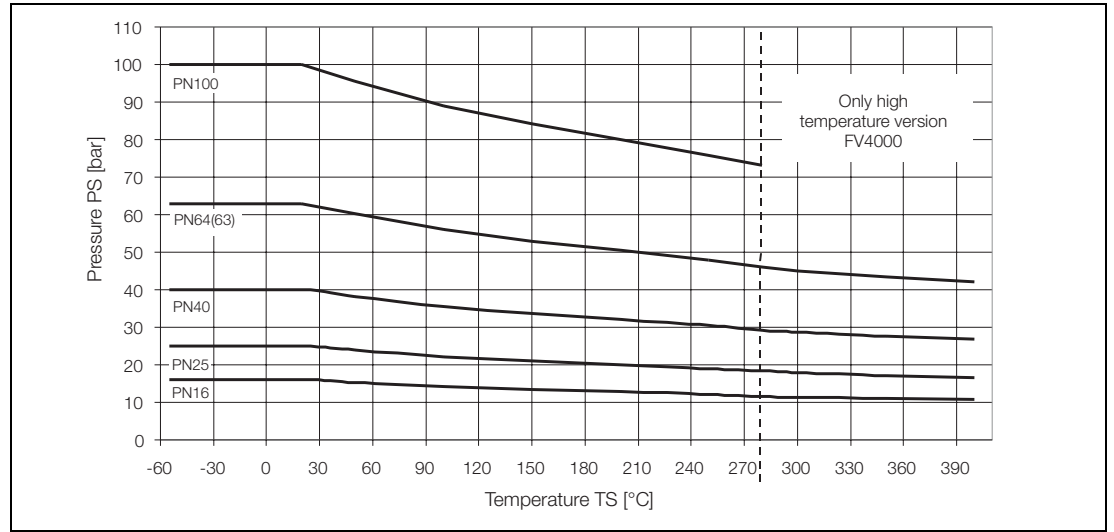

5.1.2.1 ASME-Wafer Design

SS.1.4571 [316Ti]

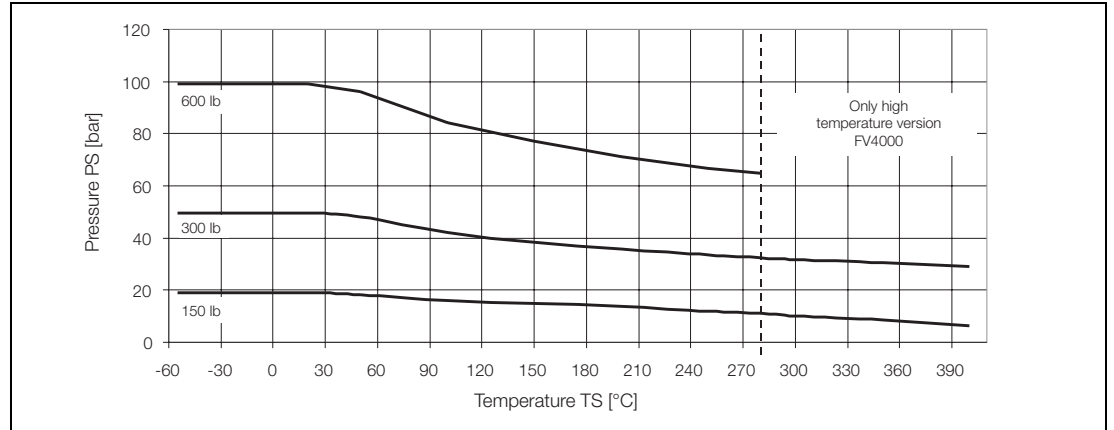

6 Electrical Interconnections

The measurement system is designed in 2-wire technology, i.e. the supply power and the current output signal (4-20 mA) use the same interconnection cable.

The separate contact output can be assigned the following functions: pulse output, min- or max alarm (temperature or flowrate) or system alarm.

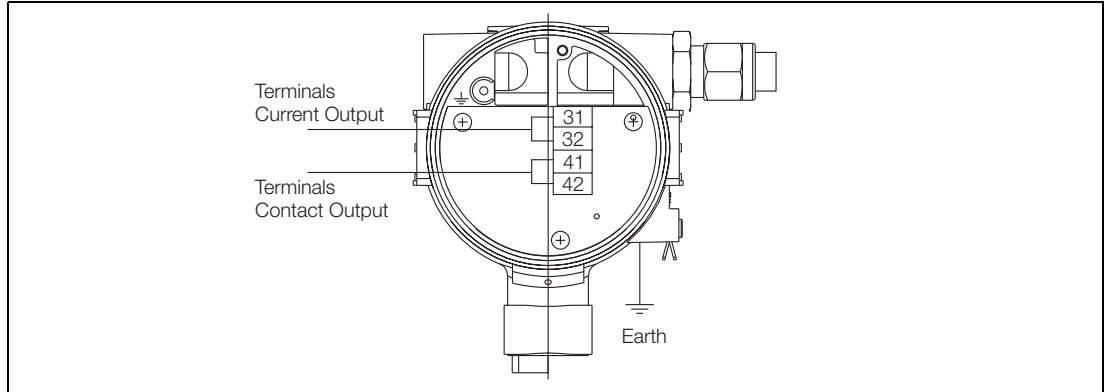

Fig. 21: Connection Box

6.1 Interconnection Examples Supply Power

a) Supply Power from a Central Voltage Supply

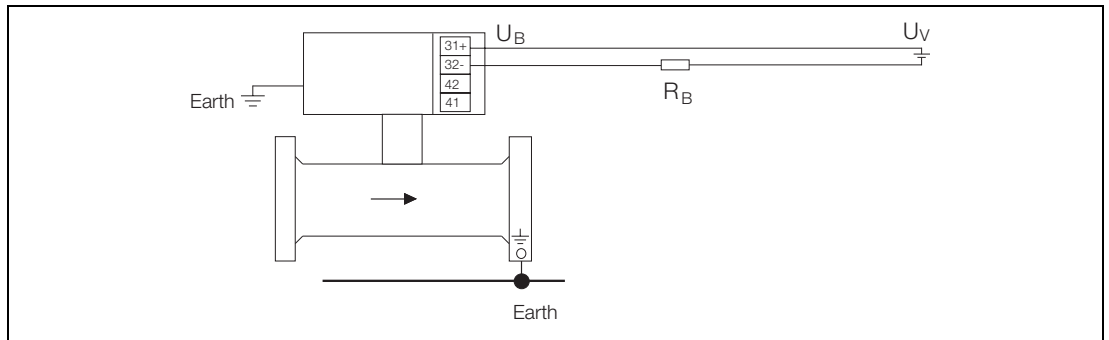

Fig. 22: Central Voltage Supply

b) Voltage Supply from a Power Supply

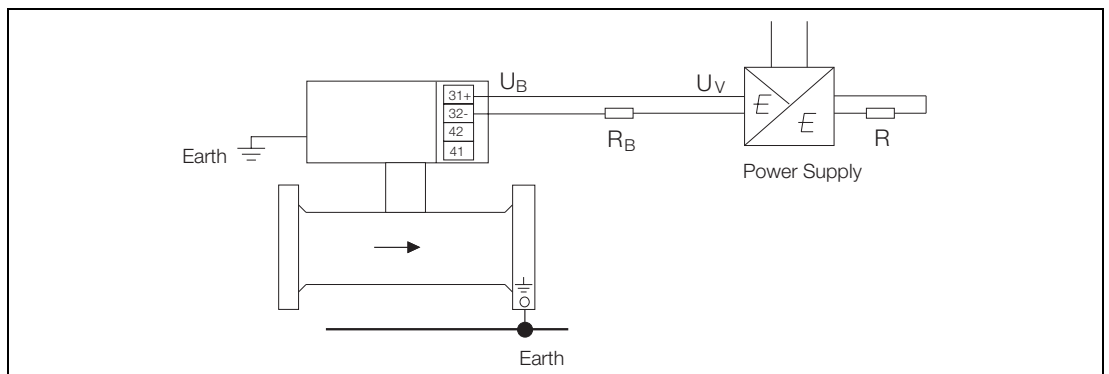

Fig. 23: Voltage Supply

- U_B = Supply voltage = min. 14 V DC
- U_V = Voltage supply, 14 - 46 V DC
- R_B = Max. allowable load for power supply (e.g. indicator, recorder, cable resistance etc.)
- R = Max. allowable load for the output circuit is defined by the power supply (e.g indicator, recorder, etc.)

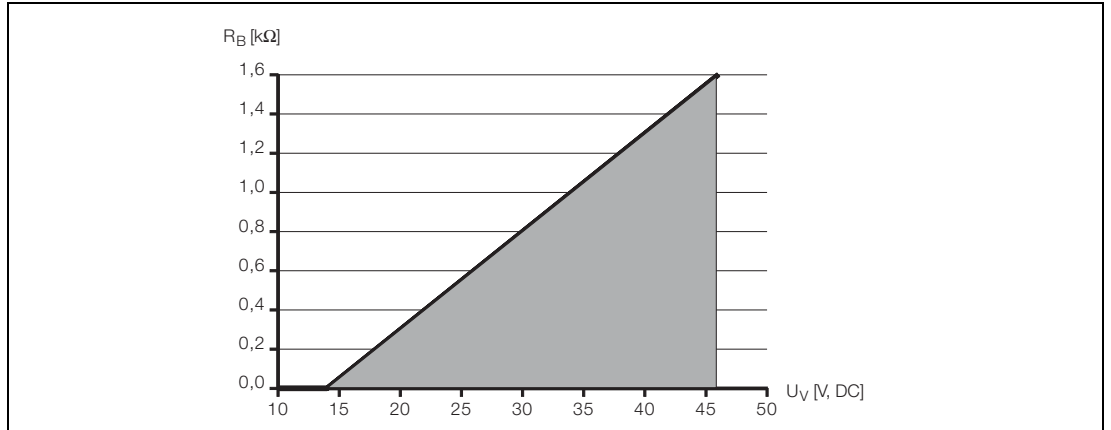

Fig. 24: Load Diagram

6.2 Interconnection Examples Contact Output

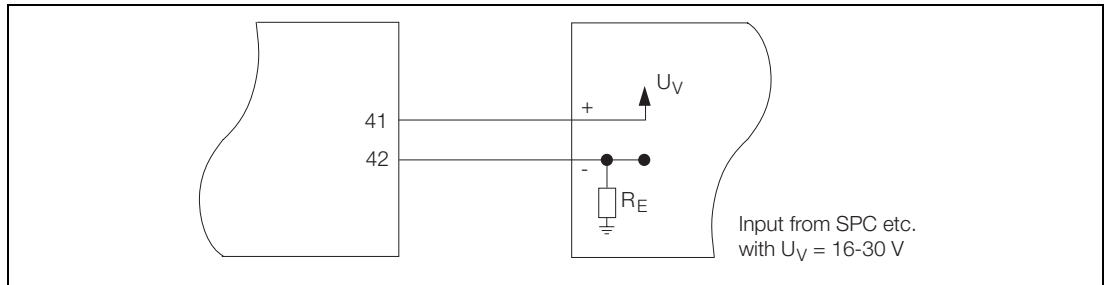

Fig. 25: Interconnection Examples Contact Output

The calculation of the resistance R_E is a function of the supply power U_V and the selected current I_B .

$$R_E = \frac{U_V}{I_B}$$

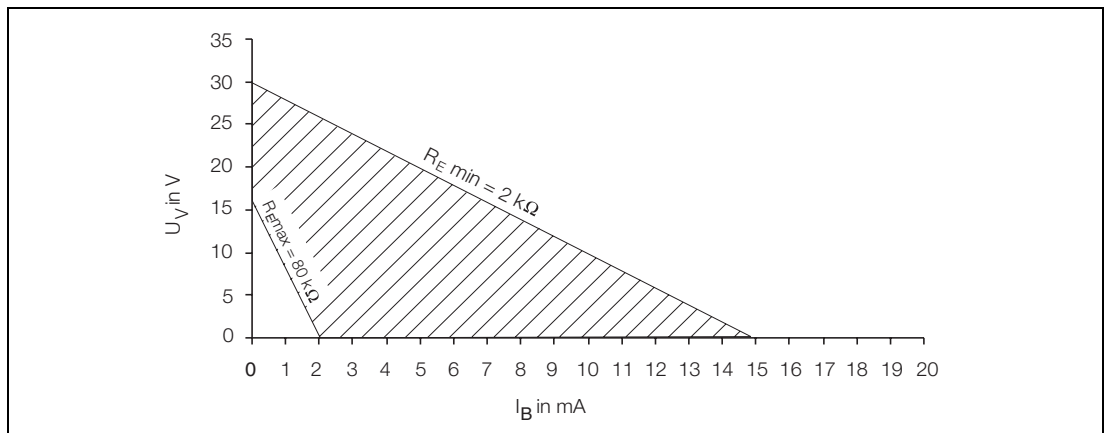

Fig. 26: Relationship R_E at the Contact Output as a Function of the Voltage and Current

7 Communication, HART®-Protocol

The HART-Protocol is used for digital communication between a process control system/PC, handheld terminal and the Vortex/Swirl flowmeters. All instrument and meter location parameters can be transmitted from the converter to the process control system or PC. In the reverse direction it is possible to configure or re-configure the converter.

The digital communication utilizes a sine wave superimposed on the current output (4-20 mA), which does not affected any of the instruments connected to the output.

Transmission Mode

FSK-Modulation on the 4 - 20 mA current output per Bell 202 Standard. Max. signal amplitude 1.2 mA_{pp}.

Logic 1: 1200 Hz

Logic 0: 2200 Hz

For the HART-Communication the WINDOWS software SMART VISION® is used.

Detailed descriptions may be obtained upon request.

Current Output Load

Min. > 250 Ω, max. 750 Ω

Max. cable length 1500 m AWG 24 twisted and shielded

Baudrate

1200 Baud

Current Output at Alarm

High = 21-23 mA (programmable)

For HART-Protocol operating information see the separate Operating Instruction D184B108U03.

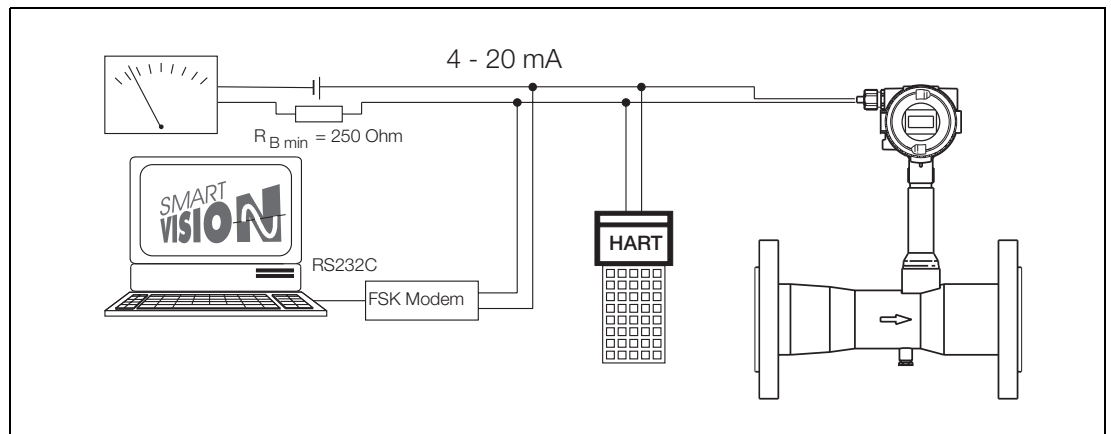

Fig. 27: HART-Communication

The latest DD/EDD-Files are also available for download on the ABB web site <http://www.abb.com/flow> → Vortex-/Swirl Flowmeter (select desired type) → more → Fieldbus & HART Files → Version Matrix (read first: all available files and documentation for the product are listed here) → close Version Matrix again → select Download Software for the desired communication HART-Protocol.

8 Vortex-/Swirl Flowmeter FV4000-VR4/FS4000-SR4

These Vortex/Swirl Flowmeters (Fig. 28) are based on the VT4/ST4 technology and include all the options of the VT4/ST4. The converter is mounted remote from the flowmeter primary when the primary is located in an inaccessible location. This design is also advantageous when extreme ambient conditions exist at the meter location. The maximum distance between the flowmeter primary and the converter is 10 m. A special cable is used to interconnect the flowmeter primary and the converter (permanently attached to the converter).

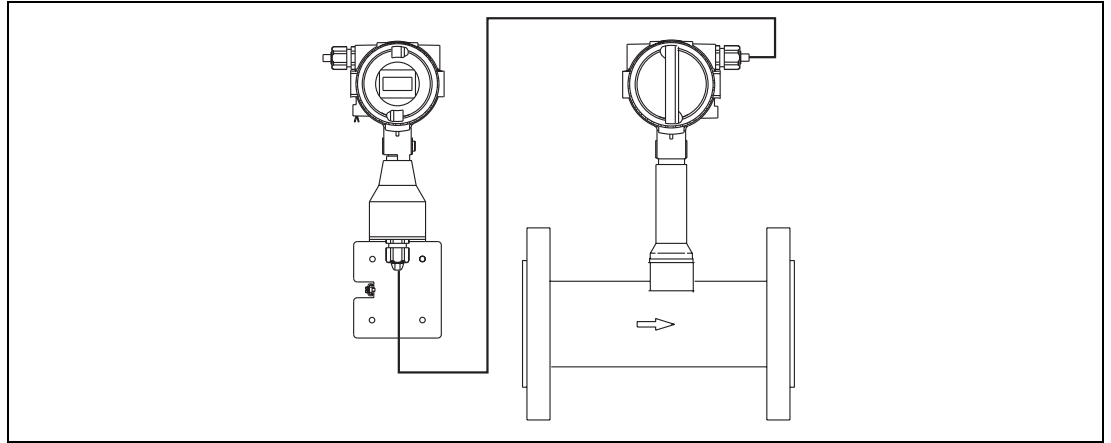

Fig. 28: Vortex/Swirl Flowmeter FV4000-VR4/FS4000-SR4

After the installation has been completed, the connection cable to the flowmeter primary can be cut to the required length. Because the signals between the flowmeter primary and converter are not amplified, the connections should be made carefully and the leads in the connection box routed so that they will not be affected by vibrations.

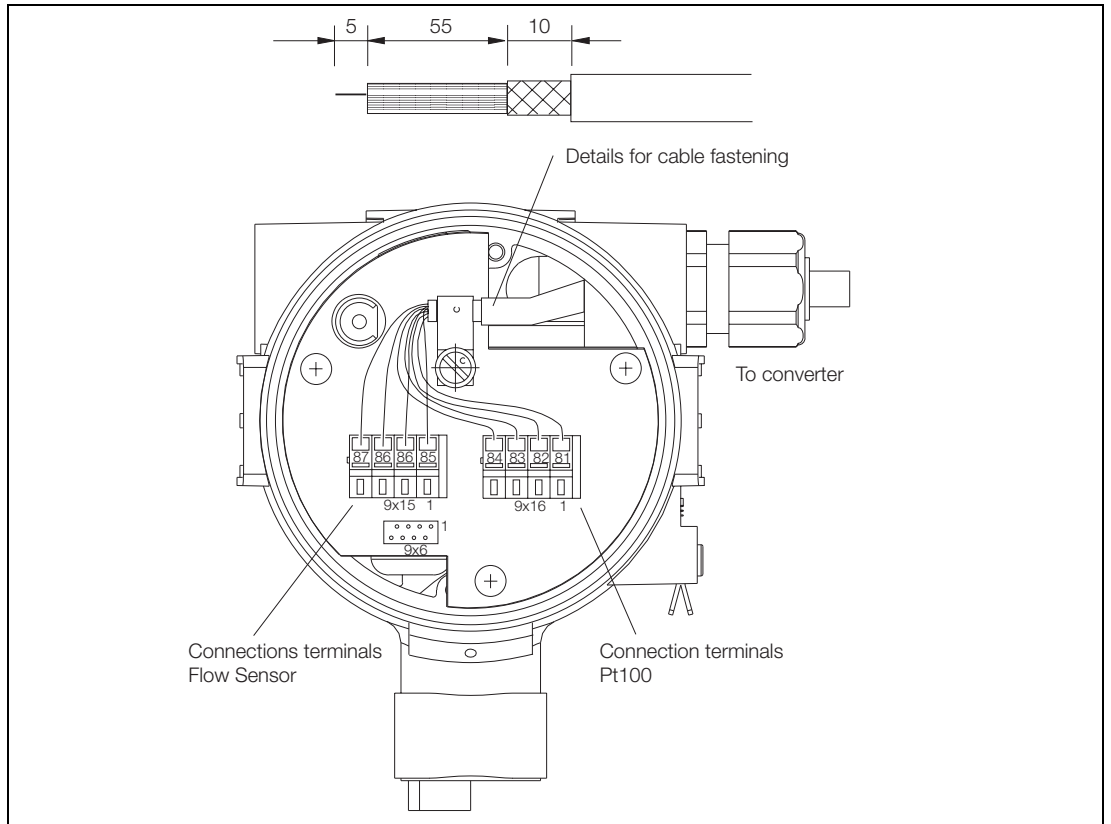

Fig. 29: Interconnection Box Flowmeter Primary

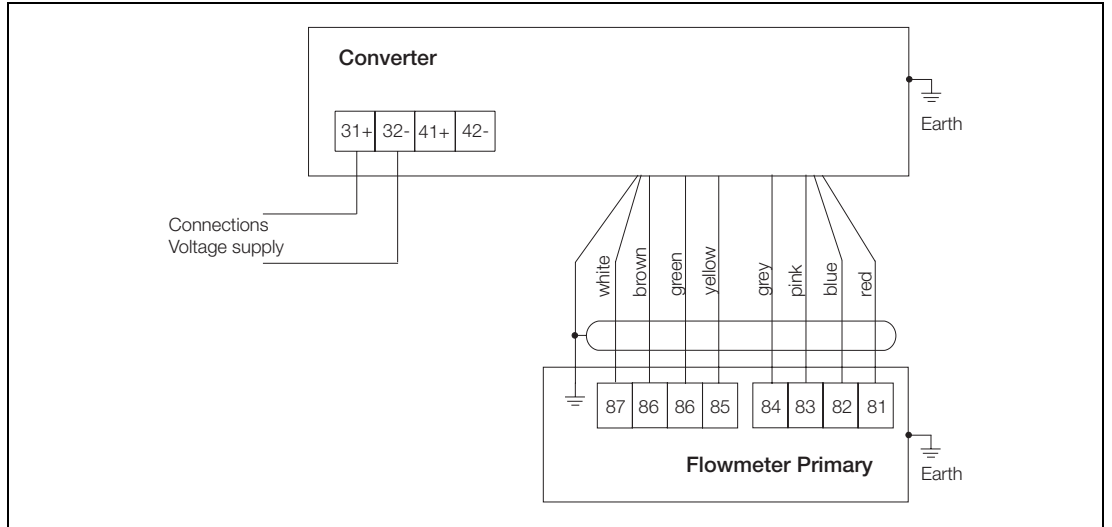

Fig. 30: Interconnections Between Converter and Flowmeter Primary

9 Data Entry/Operation and Configuration

9.1 LC Display

After the instrument is turned on a number of selftest routines are automatically executed. Upon completion, the standard display appears (process information). The display format can be user programmed.



Actual flowrate display with engineering units



Totalized actual flow



Fluid temperature

9.2 Data Entry

Data is entered using either the 3 keys DATA, STEP and C/CE on the display or using the Magnet Stick without opening the housing cover. During data entry the flowrate measurements continue.

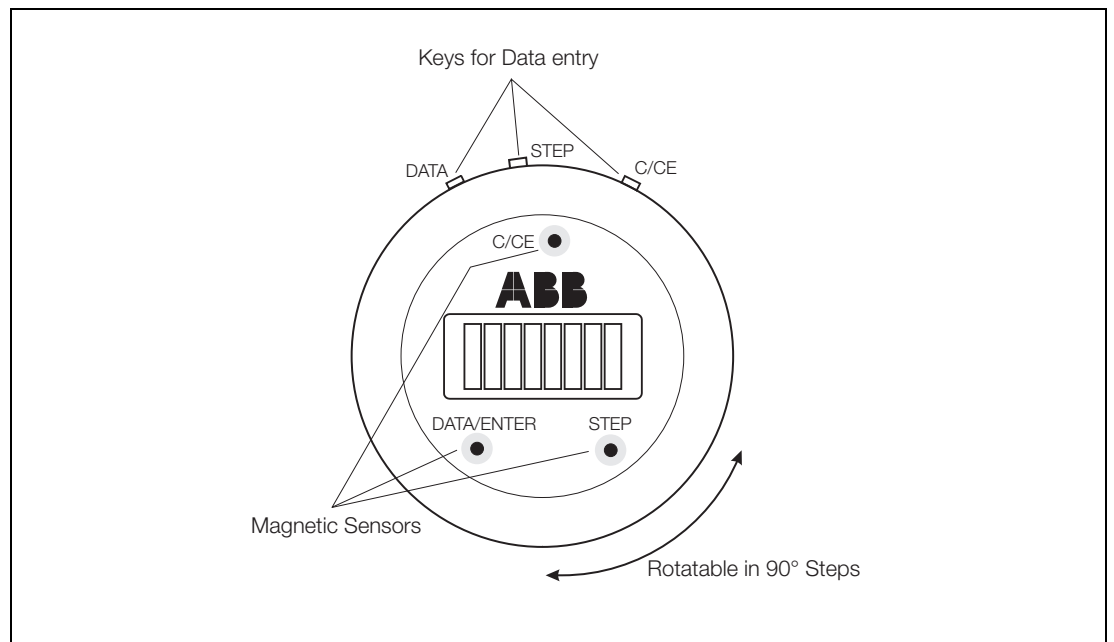







Fig. 31:

The functions of the individual keys are explained in the following:

	C/CE	The C/CE-Key is used to toggle between the operating mode and the menu mode.
	STEP ↑	The STEP-Key is one of two arrow keys. STEP is used to scroll forward through the menu. All desired parameters can be accessed.
	DATA ↓	The DATA-Key is one of two arrow keys. DATA is used to scroll backwards through the menu. All desired parameters can be accessed.
 	ENTER	The ENTER-Function is activated by pressing both arrow keys STEP and DATA simultaneously. ENTER is initially used to turn the program protection on and off. ENTER is also used to access the parameter to be changed and to accept the new selected or entered value. The ENTER-Function is only active for approx. 10 Sec. If no entry is made during this 10 sec. interval, the converter redisplay the old value. After another 10 sec. idle interval the process information is redisplayed. To initiate the ENTER-Function when using the Magnet Stick actuate the DATA/ENTER-Sensor for at least 3 seconds. The display blinks to indicate that the function is active.

9.3 Menu System - 3 Levels

1. Level: Standard Menu

The Standard menu allows can be used for quick configuration the instrument. All user specific parameters required to operate the instrument are contained in this menu.

2. Level: Specialist

Differing from the Standard menu this menu includes the complete set of user relevant parameters.

3. Level: Service

The Service menu is only accessible to the Customer Service personnel of ABB Automation Products.

9.4 Menu System

9.4.1 Turn Program Protection On and Off A

Information:

The program protection must be turned off before an entry or parameter change can be made.

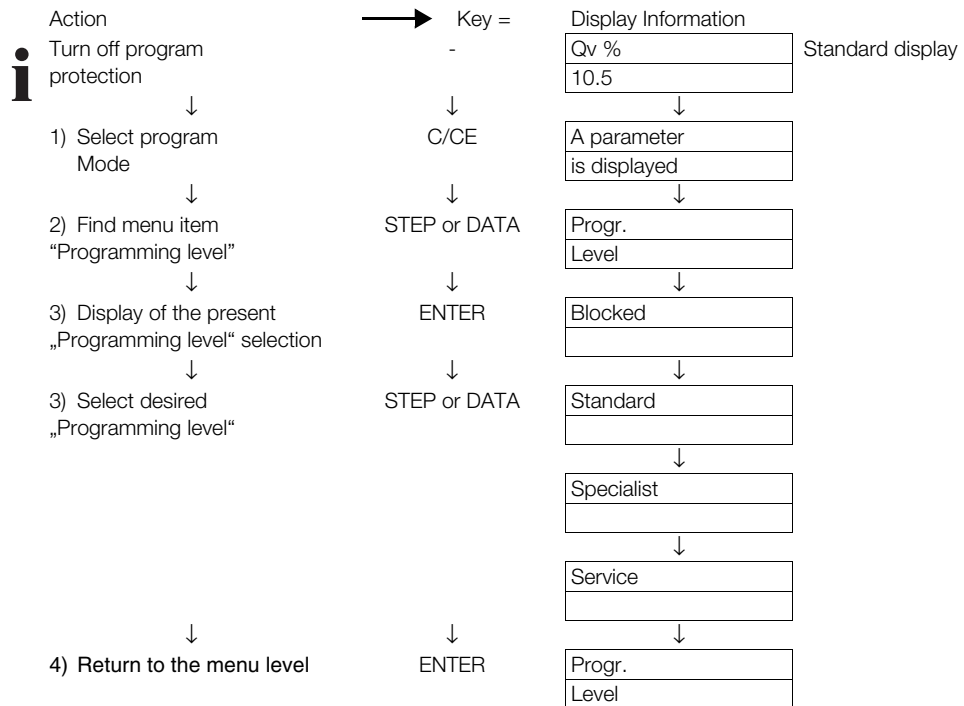

After the configuration of the converter has been completed the program protection should be turned on again.

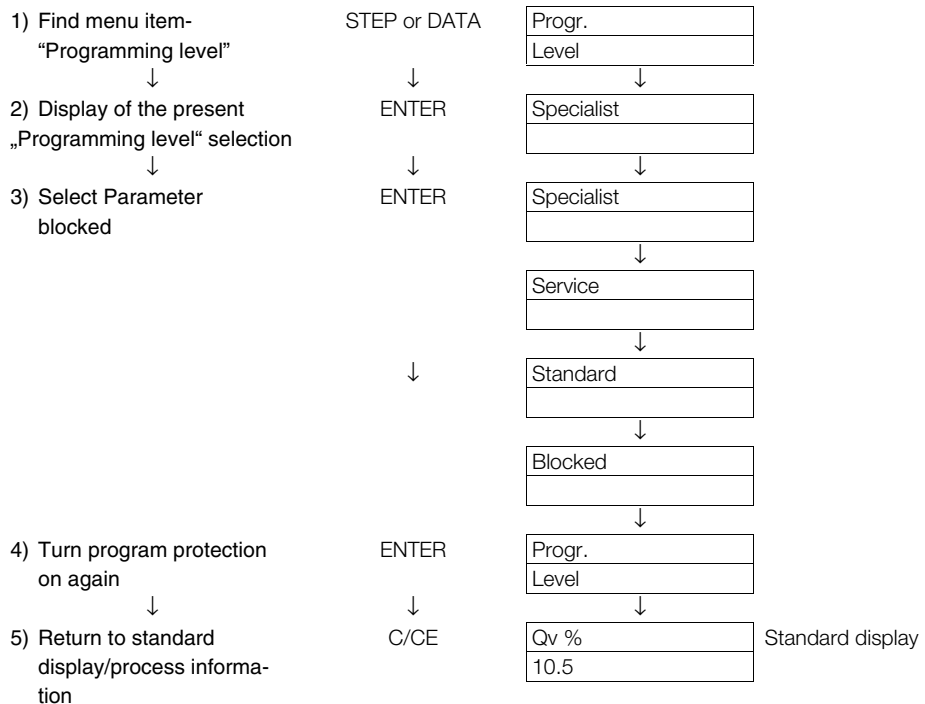

9.4.2 Parameter and Data Entry Overview

All menus shaded in gray are included in the programming level **Standard**.

Key	Submenu/Parameter	Submenu/ Present Parameter	Submenu/ Select Parameter	Selections	Entry Type	Comments
	Enter Progr. Level	Blocked	ENTER	Standard_	Standard	from table
				Specialist_	Specialist	
				Service_	SRV-Code_ enter	„Standard“: Standard menu with all the user relevant menu entries required for operating the instrument; „Specialist“: Specialist menu with the complete set of user relevant menu entries; „Service“: Additional display of the Service menu after the correct Service Code has been entered (only for ABB Service)
					ENTER	
	2x ENTER ProgProt Code	Change Code	ENTER	0		If a number other than „0“ (factory default setting) has been selected for the Prog. Prot. Code, the Prog. Prot. can only be turned off after the PP-Code (1-9999) has been entered.
		New Code	ENTER	9999		
↓ ↑	Language	English	ENTER	English_	English/German	from table
				German_		
↓ ↑	Flowmeter primary	VORTEX VT / VR	ENTER	SWIRL ST / SR	SWIRL ST/SR, VORTEX VT/VR	from table
				VORTEX VT / VR		Select flowmeter primary type SWIRL = FS4000-ST4/SR4 VORTEX = FV4000-VT4/VR4
	Meter size	D 300 mm 12in				Display of the size of the flowmeter primary A=ANSI D=DIN
↓ ↑	Avg. k-Factor	52000.0 1/m ³				Display average calibration k-Factor
	Diam. Correct.	Sched.40			Sched.40 Sched.80	Parameter is only displayed for flowmeter primaries with ASME process connections: correction for the diameter difference between the adjacent pipeline Sched. 40 or 80

Key	Submenu/Parameter	Submenu/ Present Parameter	Submenu/ Select Parameter	Selections	Entry Type	Comments
↓ ↑	Flow mode	Enter Liquid Qv	↓ ↑ ENTER Liquid Qv	1) Liquid Qv	from table	Fluid = Liquid (see Page 38)
		Information: The selection choices for the operating mode are a function of the fluid and sensor design.(see Ordering Information)		2) Liquid Qm(D)		Operating mode: Fluid = Liquid Mass (see Page 38)
				3) Liquid Qm(D,T)		Fluid = Liquid Operating mode: Mass (see Page 38)
				4) Liquid Qm(V,T)		Fluid = Liquid Operating mode: Mass (see Page 38)
				5) Gas Qv		Fluid = Gas (see Page 38)/Steam Operating mode: Actual flowrate
				6) Gas Norm Qn(pT)		Fluid = Gas (see Page 38)/Steam Operating mode: Normal flowrate
				7) Gas Norm Qn(KmpF)		Normal flowrate: Gas (see Page 38)
				8) Gas Mass Qm(pT)		Mass flowrate: Gas (see Page 38)
				9) Gas Mass Qm(D)		Mass flowrate: Gas (see Page 38)
				10) S-Steam Qm		Mass flowrate: Saturated steam (see Page 38)
				11) S-Steam Qv		Actual flowrate: Saturated steam (see Page 38)
↓ ↑	Units Density	Enter kg/l	↓ ↑ ENTER kg/m3	g/l, g/cm ³ , g/l, kg/l, kg/l, kg/m ³ , lb/ft ³ , lb/ugl, g/ml,	from table	Menu displayed for selection: Liquid Qm (D,T), Liquid Qm (V,T), Gas Mass Qm (pT), Gas Mass Qm(D)
↓ ↑	Ref. density	Enter 1.000 kg/l	↓ ↑ ENTER 0 kg/l	0.001 - 1000.000	from table	Menu displayed for selection: Liquid Qm (D,T), Liquid Qm (V,T), Gas Mass Qm(D)
↓ ↑	Normal dens.	Enter 0.001 kg/l	↓ ↑ ENTER 0 kg/l	0.000 - 0.100	from table	Menu displayed for selection: Gas Mass Qm (pT)
↓ ↑	Normal factor	Enter 1.000	↓ ↑ ENTER 0	0.001 - 1000.000	numeric	Menu displayed for selection: Gas Normal Qn(Kmpf) Normal factor = $\rho_b : \rho_0$ (see Page 38)
↓ ↑	Normal cond.	Enter 1.0133 bara 0 °C	↓ ↑ ENTER 1,0133 bara 20 °C			Menu displayed for selection Gas Mass Qm(pT) Gas Normal Qn (pT)

Legends for liquids, gases and steam calculations:

- | | |
|--------------------------------------|---------------------------------------------|
| 1) Liquid Qv = Volume flowrate | 7) Gas Norm Qn(Kmpf) = Normal flowrate |
| 2) Liquid Qm(D) = Mass flowrate | 8) Gas Mass Qm(pt) = Mass flowrate |
| 3) Liquid Qm(D,T) = Mass flowrate | 9) Gas MassQm(D) = Mass flowrate |
| 4) Liquid Qm(V,T) = Mass flowrate | 10) S-Steam Qm = Sat. steam mass flowrate |
| 5) Gas Qv = Actual flowrate | 11) S-Steam Qv = Sat. steam volume flowrate |
| 6) Gas Norm Qn(pT) = Normal flowrate | |

Key	Submenu/Parameter	Submenu/ Present Parameter	Submenu/ Select Parameter	Selections	Entry Type	Comments
↓ ↑	Units Temp	Enter °C	↓ ↑ ENTER F	°C, F, K	from table	
↓ ↑	Reference Temp	Enter 20.0 °C		-200.0 - 500.0		Menu displayed for selection: 2, 3 and 7 see Legends Pg. 34
↓ ↑	Pressure Poper abs	Enter 1.0 bar				Menu displayed for selection: Gas Mass Qm(pT)
↓ ↑	Vol. Expansion	Enter 1.00 %./K				Menu displayed for selection: Liquid Qm(V,T)
↓ ↑	Units Qvol	Enter m3/h	↓ ↑ ENTER m3/d	Qvol and Qm dependent on „Operating mode“ selection! l/s, l/m, l/h, m ³ /s, m ³ /m, m ³ /h, m ³ /d ft ³ /s, ft ³ /m, ft ³ /h, ft ³ /d, usgps, us-gpm, usgph, usmgd, igps, igpm, igph, igpd, bbl/s, bbl/s, bbl/h, bbl/d		Selection of the volume units for Qv, Qn and Qs
↓ ↑	Units Qm	Enter kg/s	↓ ↑ ENTER kg/h	kg/s, g/h, kg/s, kg/m, kg/h, kg/d, t/m, t/h, t/d, lb/s, lb/m, lb/h, lb/d	from table	Menu displayed for selection: 2, 3, 7, 8, 9 Legends see Page 34
↓ ↑	Qmax DN Actual	Enter 84.000 m3/h	↓ ↑ ENTER			Display max. flowrate for the selected size
↓ ↑	Qmax	Enter 84.000 m3/h	↓ ↑ ENTER 0 m3/d	0.15-1.15 x Qmax DN numeric Operating mode	numeric	QmaxDN end value for selected flow mode (= 20 mA)
↓ ↑	Qmin Actual	Enter 1.000 m3/h	↓ ↑ ENTER 0 m3/h	0-10 % Qmax DN Volume	numeric	Low flow cutoff value Cannot be changed!
↓ ↑	Totalizer	Enter Totalizer value	↓ ↑ ENTER 0.0000 m3		numeric	Set the totalizer value to a specific start value
		Over-flow	Enter 10			Display of the number of totalizer overflows; max. 65,535 1 overflow = 10,000,000
		Units Totalizer	↓ ↑ ENTER m3	m ³ , ft ³ , usgal, igal, igl, bbl, l, g, kg, t, lb	from table	Selection of the totalizer units as a function of the selected operating mode Volume or mass flowrate
		Totalizer reset	Enter Reset -> Enter	Enter		Reset the totalizer and overflow counter
↓ ↑	Damping	Enter 50.0 s	↓ ↑ ENTER 0 s	0.2 - 100 s	from table	Damping setting for the current output Response time 1 τ (= 63 %) for a step flow change
↓ ↑	Hardware Config.	Enter I/HART	↓ ↑ ENTER I/HART		from table	Configure contact output: Current, HART-Protocol.
			I/HART/Pulse_Bin			Current, HART-Protocol Contact output: pulse

Key	Submenu/Parameter	Submenu/ Present Parameter	Submenu/ Select Parameter	Selections	Entry Type	Comments	
			I/HART/ Q_Alarm_ --			Current, HART-Protocol, Contact output: Limit alarm flowrate closed for alarm	
			I/HART/ T_Alarm_ --			Current, HART-Protocol, Contact output: Limit alarm temperature closed for alarm	
			I/HART/ S-Alarm_ --			Current, HART-Protocol, Contact output: System alarm closed for alarm	
		Information: Menus Min. and Max. Q_Alarm only displayed when I/HART/Q_Alarm is selected.					
↓ ↑	Min. Q_Alarm --	Enter 10.000 %_ -- --	↓ ↑ ENTER %_ -- --	0 - 100 % of Qmax	numeric	Min alarm flowrate 0 % = off	
↓ ↑	Max. Q_Alarm --	Enter 80.000 %_ -- --	↓ ↑ ENTER %_ -- --	0 - 100 % of Qmax	numeric	Max alarm flowrate 100 % = off	
		Information: Menus Min. and Max. T_Alarm only displayed when I/HART/T_Alarm is selected.					
↓ ↑	Min. T_Alarm --	Enter 50 C_ -- --	↓ ↑ ENTER C_ -- --	-60 °C to 410 °C	numeric	Min alarm Temperature -60 °C = off	
↓ ↑	Max. T_Alarm --	Enter 180.000 C_ -- --	↓ ↑ ENTER C_ -- --	-60 °C to 410 °C	numeric	Max alarm Temperature 410 °C = off	
↓ ↑	Out at Alarm --	Enter 22.4 mA_ -- --	↓ ↑ ENTER mA_ -- --	21-26 mA	numeric	Current output value for alarm programmable	
↓ ↑	Pulse Factor --	Enter 100.000 1/m3_ -- --	↓ ↑ ENTER 5 1/m3_ -- --	0.001 - 1000 Pulses/unit	numeric	For internal and external flow totalizers	
		Information: Menu pulse width only displayed when I/HART/Pulse_Bin has been selected.					Selected units for output
↓ ↑	Pulse width --	Enter 10 ms_ -- --	↓ ↑ ENTER 0 ms_ -- --	1 - 256 ms	numeric	Max. 50 % on/off . Warning is displayed if exceeded.	
↓ ↑	Submenu Display --	Enter Main Display --	↓ ↑ ENTER Q Oper.- art_ -- --		from table	Select main display	
			Qv Operate --	Qv Actual normal, standard			
			Percent_ --	Qm Mass Percent Totalizer			
			Totalizer_ --	Temperature Frequency			
			Tempera- ture_ --				
			Frequency_ --				
			None_ --				
↓ ↑	Multip. Display --	↓ ↑ ENTER Q Oper.- mode_ -- --			from table	Select the multiplex display mode	

Key	Submenu/Parameter	Submenu/ Present Parameter	Submenu/ Select Parameter	Selections	Entry Type	Comments
			Qv Actual			
			Percent			
			Totalizer			
			Temperature			
			Frequency			
			None			
		2nd line multi off	Enter Off	On		2nd line multiplex operation „On“ or „Off“
ENTER	Error Register	ENTER Error . . . 3 . . .				Display detected error Reset with „ENTER“ (see also Information Chapter 9.6)
		Mains interrupt	Enter 10			Number of mains interrupts since start-up
ENTER	Function test	ENTER Iout	Enter 0 %	0 to 115 %	numeric	Test current output manual control (100 % = 20 mA)
		Q Simulation	0 Hz	0 to 2500 Hz	Sensor frequency	Simulation (current and pulse outputs). Turn on by entering the start value in “Hz”. Turn off by entering “0” Hz. After switching to process display, the frequency can be varied using Data/Step (+/-5Hz).
		EEPROM			Automatic test	Test EEPROM (used to store the meter location parameters)
		Contact output				Toggle „open“ or „closed“
		Pulse output			0=Pulse 1=No pulse	
		HART-Transwith			.	
		HART-Command			--	Test HART-Receiver
ENTER	Instrument-address				0-15	- for HART-Protocol 1-15 - 1-15 Multidrop operation
ENTER	50VT4000 06/2000	ENTER D699C00x U01 A.16				Display installed software version and its revision date Entry = Display installed revision number

9.4.3 Configurations for Gas, Steam and Liquids

The following table lists the various operating modes available for the different fluids together with the menu items which are displayed for each operating mode.

Operating Mode ¹⁾	Fluid	Flow Measurement Type	Equations	Correction-Parameter	Additional Menu Items Displayed
Liquid Qv	Liquid	Volume flowrate	—	—	—
Liquid Qm(D)	Liquid	Mass flowrate	$Qm = Qv \cdot \rho_b$	Reference density constant ρ_b	Units density Reference density Units Qm
Liquid ²⁾ Qm (D, T)	Liquid	Mass flowrate	$Qm = Qv \cdot \rho(T_b)$ $\rho(T) = \rho_0 \cdot (1 + (T_b - T_0) \cdot \beta_2)$	Reference density ρ_b Reference temp. T_0 Measured temp. T_b Density exp. coef. β_2	Units density Reference density Reference temp. Units Qm
Liquid ²⁾ Qm (V, T)	Liquid	Mass flowrate	$Qm = Qn \cdot \rho_b$ $Qn = \frac{Qv}{(1 + (T_b - T_0) \cdot \beta_1)}$	Vol. exp. coef. [%/K] β_1 Reference temp. T_0 Measured temp. T_b Reference density ρ_b	Units density Reference density Reference temp. Vol._Expansion Units Qm
Gas Qv	Gas/ Steam	Actual flowrate	—	—	—
Gas Normal ²⁾ Qn (pT)	Gas	Normal flowrate 1.013 bar/0 °C 0–1.013 bar/20 °C	$Qn = Qv \cdot \frac{Poper}{1.013 \text{ bar}} \cdot \frac{273 \text{ K}}{273 \text{ K} + T_b}$	Operating press. Poper abs Measured temp. T_b	Operating press. Units pressure Normal condition
Gas Std ²⁾ Qs (pT)	Gas	Standard flowrate 14.7 psia/60 °F	$Qs = Qv \cdot \frac{Poper}{14.7 \text{ psia}} \cdot \frac{60 \text{ °F}}{60 \text{ °F} + T_b}$	Operating press. Poper abs Measured temp. T_b	Operating press. Units pressure Normal condition
Gas Normal Qn (KmpF)	Gas	Normal flowrate 1.013 bar/0 °C	$Qn = Qv \cdot \text{Normalfactor}$ $\text{Normalfactor} = \frac{\rho_b}{\rho_0}$	Normal factor constant (Compressibility factor)	Normal factor
Gas Mass ²⁾ Qm (pT)	Gas	Mass flowrate Normal conditions 1.013 bar/0 °C or 1.013 bar/20 °C	$Qm = \rho_0 \cdot Qn$ $Qn = Qv \cdot \frac{Poper}{1.013 \text{ bar}} \cdot \frac{273 \text{ K}}{273 \text{ K} + T_b}$	Operating press. Poper abs Normal density ρ_0 Measured temp. T_b	Units density Normal density Normal condition Reference temp. Press._Poper_abs Units Qm
Gas Mass Qm (D)	Gas/ Steam	Mass flowrate	$Qm = Qv \cdot \rho_b$	Reference density constant ρ_b	Units density Reference density Units Qm
S-Steam ²⁾ Qm	Sat. steam	Mass flowrate	$Qm = Qv \cdot \rho_b(T_b)$ Corrections using steam tables	Measured temp. T_b	Units Qm
S-Steam Qv	Sat. steam	Actual flowrate	—	—	—

- Qm = Mass flowrate
- Qv = Actual flowrate
- Qn = Normal flowrate
- Poper = Operating pressure
- β_1 = Volume expansion coefficient
- β_2 = Density expansion coefficient
- ρ_0 = Normal density
- ρ_b = Operating density

¹⁾ The selection from the operating mode options depends on the type of calibration of the flowmeter.

²⁾ These operating modes can only be selected when the flowmeter has a temperature sensor installed.

9.4.4 Configuration of the Converter for Start-up

The flowmeter system was preconfigured by ABB based on the ordering information and all the required values entered. Since the instruments can be universally installed, (i.e. for liquids or gases) it is recommended that the following parameters in the software be checked or changed prior to start-up:

- **Meter Size:**
Check against size on factory tag
- **K-Factor:**
The displayed value must agree with the value on the primary tag.
- **Operating mode:**
Select the desired flow mode. See Page 30.
- Which units are to be used for the flowrate to be displayed and the totalized flow? Select either volume or mass units (depends on the operating mode selected).
- Enter the desired flow range in the units selected above in the parameter Q_{\max} Operating Mode. Available ranges from 0.15 to $1.15 \times Q_{\max \text{ DN}}$ actual.
- **Qmin Actual:**
Check the low flow cutoff range : Range 0.05 to $0.1 \times Q_{\max \text{ DN}}$.
- **Units Totalizer:**
Parameter for selecting the flow units for the internal totalizer. This selection also applies to the pulse output (contact output, terminals 41/42).
- **Damping:**
The response time for the electronic circuits, applies to the local display indication, pulse output and Transducer Block.
- **Submenu Display:**
Select the information to be shown on the local display.
- If necessary, configure the contact output.

9.5 Additional Configuration Information

9.5.1 Meter Size

This parameter is used to match the converter to the individual flowmeter primaries since the identical converter is used for all flowmeter sizes. The flowmeter size is set at the factory for the associated flowmeter primary (see primary tag).

9.5.2 Calibration K-Factor

The average k-Factor value shown in the display must be the same as the value on the primary tag on the flowmeter primary. Each instrument is calibrated at 5 flowrates on a test stand. The calibration factors are entered in the converter and recorded in the test report. The average calibration factor is calculated and engraved on the flowmeter primary. The following table lists typical k-Factors and frequencies for liquids and gases for each flowmeter size. These are approximate values only:

Vortex Flowmeters FV4000-VT4/VR4

Meter Size		Typ. ¹⁾ k-Factor max [1/m ³]	Liquid ¹⁾ f _{max} at Q _{vmax} [Hz]		Gas ¹⁾ f _{max} at Q _{vmax} [Hz]	
DN	Inch		DIN	ANSI	DIN	ANSI
15	½"	225000	370	450	1520	1980
25	1"	48000	240	400	2040	1850
40	1½"	14500	190	270	1550	1370
50	2"	7500	140	176	1030	1180
80	3"	2100	102	128	700	780
100	4"	960	72	75	500	635
150	6"	290	50	50	360	405
200	8"	132	45	40	285	240
250	10"	66	29	36	260	225
300	12"	39	26	23	217	195

Swirl Flowmeters FS4000-ST4/SR4

Meter Size		Typ. ¹⁾ k-Factor max [1/m ³]	Liquid ¹⁾ f _{max} at Q _{vmax} [Hz]	Gas ¹⁾ f _{max} at Q _{vmax} [Hz]
DN	Inch			
15	½"	440000	185	1900
20	¾"	165000	100	1200
25	1"	86000	135	1200
32	1¼"	33000	107	1200
40	1½"	24000	110	1330
50	2"	11100	90	1100
80	3"	2900	78	690
100	4"	1620	77	700
150	6"	460	40	470
200	8"	194	23	270
300	12"	54	16	92
400	16"	27	13	80

The converter uses the following equation to calculate the actual flowrate:

$$Q = \frac{f}{k}$$

- Q =Actual flowrate [m³/s]
- f =Frequency [1/s]
- k =Calibration k-Factor [1/m³]

1) The listed values are typical k-Factors and frequencies for each flowmeter design. The exact values may be found in the test report accompanying the shipment.

9.5.3 Submenu Hardware Configuration (contact output, terminals 41/42)

This submenu can be utilized to define the configuration of the contact output (terminals 41, 42). Dependent on the selected output mode (pulse, flowrate alarm, temperature alarm, system alarm) the menus „Pulse width“, „Min and Max Q_Alarm“ or „Min and Max T_Alarm“ are displayed.

9.5.4 Configuration of the Contact Output

The contact output has been preconfigured at the factory based on the ordering information:

Order Code	Ex-Approval	Contact Design
VT40, VR40, ST40, SR40	none	Optocoupler
VT41, VR41, ST41, SR41	II 2G EEx ib / II 3G EEx nA [L]	NAMUR-Contact
VT42, VR42, ST42, SR42	II 2G EEx d / II 2G EEx ib / II 3G EEx nA [L]	Optocoupler
VT43, VR43, ST43, SR43	FM	Optocoupler

If required, the contact configuration can be changed in the field to satisfy the system requirements. The flowmeter power should be turned off, unscrew the cover (observe the wait time specifications for Ex-Designs, see starting on Page 43). The converter must be removed to change the switches. Loosen the 3 Philips head screws and remove the converter. Set the switches as shown in Fig. 32. Carefully reinstall the converter in the housing, taking special care to center it and reinstall the 3 screws. Screw on the cover.

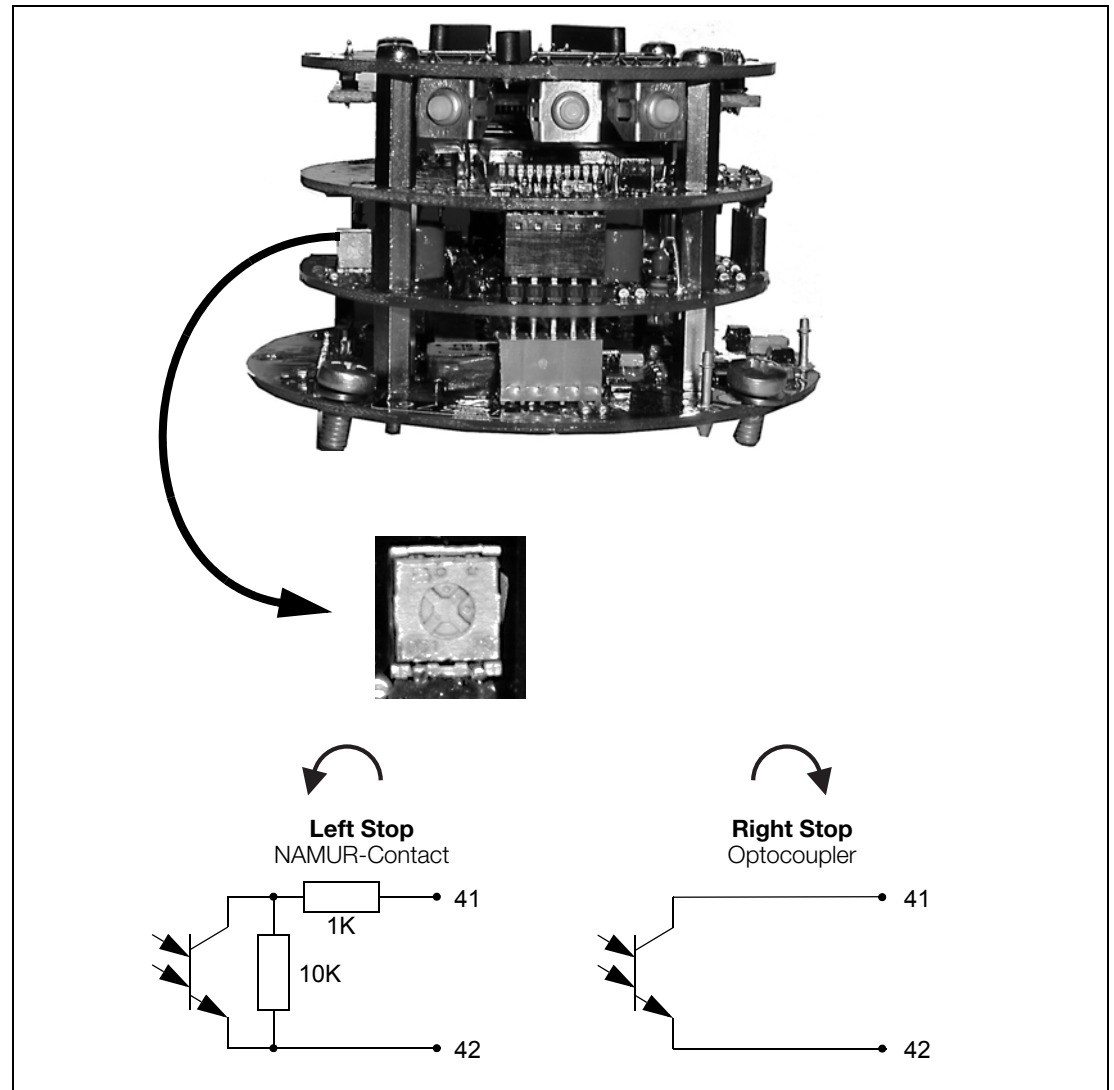

Fig. 32: Contact Output Schematic

9.6 Error Register

This submenu contains the error register and the mains interrupt counter.

All errors detected, whether momentary or long term, are permanently stored in the error register. Each number or letter defines a specific error condition:

Ok:.....Error.....3.56....

The error register can be cleared by pressing the „ENTER“-Key.

Error Code	Clear Text	Priority	Description	Possible Cause	Corrective Measures
0	Steam calculation	7	Erroneous mass flowrate calculation for saturated steam	Steam temperature < 55 °C	Increase steam temperature
				Steam temperature > 370 °C	Decrease steam temperature
1	Front End	1	Preamplifier board damaged	—	Exchange converter module/contact ABB Service
2	Not used	—			
3	Flowrate > 115 %	2	The Qmax flowrate value entered was exceeded by 15 %.	Flow range too small	Increase flow range Qmax
				Flowrate too large	Reduce flowrate
4	Not used	—			
5	M-Database	0	Main database corrupted, loss of the internal database in the converter	Internal database corrupted	Turn instrument off and on, if necessary exchange converter, contact ABB Service
6	Totalizer defect	1	Flow totalizer corrupted. Displayed value invalid		Reprogram totalizer
7	Temperature (error is only displayed when a PT100 is installed in the flowmeter primary)	7	Temperature measurement incorrect	PT100 defective	Exchange sensor
				For Models VR/SR interconnection cable miswired between flowmeter primary and converter	Check wiring
8	Not used	—			
9	Qv > 115 % QmaxDN	2	Max. possible flow range (QmaxDN) exceeded		Reduce flowrate
B	B-Base	0	Backup database corrupted, loss of the external database (sensor board)	External database corrupted	Turn instrument off and on, if necessary exchange sensor board, contact ABB Service

9.6.1 Mains Interrupt

The converter counts the number times the power has been turned off. The value is displayed in this menu item.

The counter can only be reset by ABB-Service.

9.7 Normal Factor

For constant operating conditions (pressure and temperature constant) the normal factor can be entered here. The normal factor defines the relationship between the normal and actual flowrates:

$$\frac{Q_n}{Q_v} = \frac{(1.013 \text{ bar} + p)}{1.013 \text{ bar}} \cdot \frac{273}{273 + T}$$

Q_n = Normal flowrate
 Q_v = Actual flowrate
 p = Operating pressure [bar gauge]
 T = Temperature [°C]
 ρ_v = Operating density
 ρ_n = Normal density

Since the mass flowrate is the same, the following equation also applies:

$$\frac{Q_n}{Q_v} = \frac{\rho_v}{\rho_n}$$

10 Specifications Ex-Design

Two Ex-Design instrument versions are available which have been granted European approvals. They are the Models VT41/ST41/VR41/SR41 as well as the Models VT42/ST42/VR42/SR42.

American approvals have been granted for the Models VT43/ST43/VR43/SR43.

The Models VT41/ST41/VR41/SR41 include the following approvals in a single instrument:

- Operation in Zone 1:
II 2G EEx ib IIC T4 (intrinsically safe supply)
- Operation in Zone 2:
II 3G EEx nA [L] IIC T4 (non-intrinsically safe supply)
- Operation in Zone 21:
II 2D T85 °C ... T_{med} IP67 (non-intrinsically safe supply or intrinsically safe supply)



Important!

The Ignition Types are noted on the name plate. Flowmeters, which were operated in Category 3 (Zone 2/22), may subsequently, without modification, be operated in Category 2 (Zone 1/21). The existing maximum specification values must be observed.

The Models VT42/ST42/VR42/SR42 include the following approvals in a single instrument:

- Operation in Zone 1:
II 2G EEx d [ib] IIC T6 (non-intrinsically safe supply)
- Operation in Zone 1:
II 2G EEx ib IIC T4 (intrinsically safe supply)
- Operation in Zone 2:
II 3G EEx nA [L] IIC T4 (non-intrinsically safe supply)
- Operation in Zone 21:
II 2D T85 °C ... T_{med} IP67 (non-intrinsically safe supply or intrinsically safe supply)



Important!

The Ignition Types are noted on the name plate. For operation in Zone 1 the user defines the Ignition Type by the type of supply utilized. Flowmeters, which were operated in Category 3 (Zone 2/22), may subsequently, without modification, be operated in Category 2 (Zone 1). Within Category 2 the design EEx d [ib] may subsequently, without modification, be operated as EEx ib. The existing maximum specification values must be observed. The significant differences between the versions are listed in the table on Page 44. Detailed descriptions may be found in Chapter 10.1.

Safety Relevant Specification Differences for the Explosion Protected Designs

Differences	Models					
	VT42/ST42 VR42/SR42	VT42/ST42 VR42/SR42 VT41/ST42 VR41/SR41	VT42/ST42 VR42/SR42 VT41/ST42 VR41/SR41	VT42/ST42 VR42/SR42 VT41/ST42 VR41/SR41	VT42/ST42 VR42/SR42 VT41/ST42 VR41/SR41	VT43/ST43 VR43/SR43
Ignition Type	EEx d [ib]	EEx ib	EEx nA [L]	Dust/Housing	XP	IS
Zone (Category)	1 (2G)	1 (2G)	2 (3G)	21 (2D)	Class I DIV 1	Class I, II, III DIV 1
Ex-Protection relevant housing components	Pressure tight cable connector, cover safety seal	none	none	Cover safety seal	NPT-Threads prepared for pipe connection, Cover safety seal	
Wait time when opening the converter	2 minutes	2 minutes	2 minutes	2 minutes	2 minutes	no
Temperature Class	T6 (Primary T4)	T4	T4	T85 °C ... T _{fld}	T4	T4
Allowable ambient temperature	-.41	(-55) -20 to +70 °C	-20 to +70 °C	-20 to +60 °C	-	-
	-.42	(-40) -20 to +60 °C	-	-20 to +60 °C	-	-
	-.43	-	-	-	-20 to +70 °C	-
Supply voltage	U _m = 60 V U _B = 14-46 V	ib: U _I = 14-28 V	U _m = 60 V U _B = 14-46 V	U _m = 60 V U _B = 14-46 V U _I = 14-28 V	U _B = 14-46 V	V _{max} = 14-28 V



10.1 Specifications Converter

10.1.1 Design EEx „ib“ / EEx „n“ for VT41/ST41 and VR41/SR41 (4-20 mA/HART)



Operation in explosion hazardous areas is only permissible when the housing is completely closed

EC-Type Examination Certificate TÜV 99 ATEX 1465

Identification:



II 2G EEx ib IIC T4
 II 3G EEx nA [L] IIC T4
 II 2D T 85 °C ... T_{med} IP67

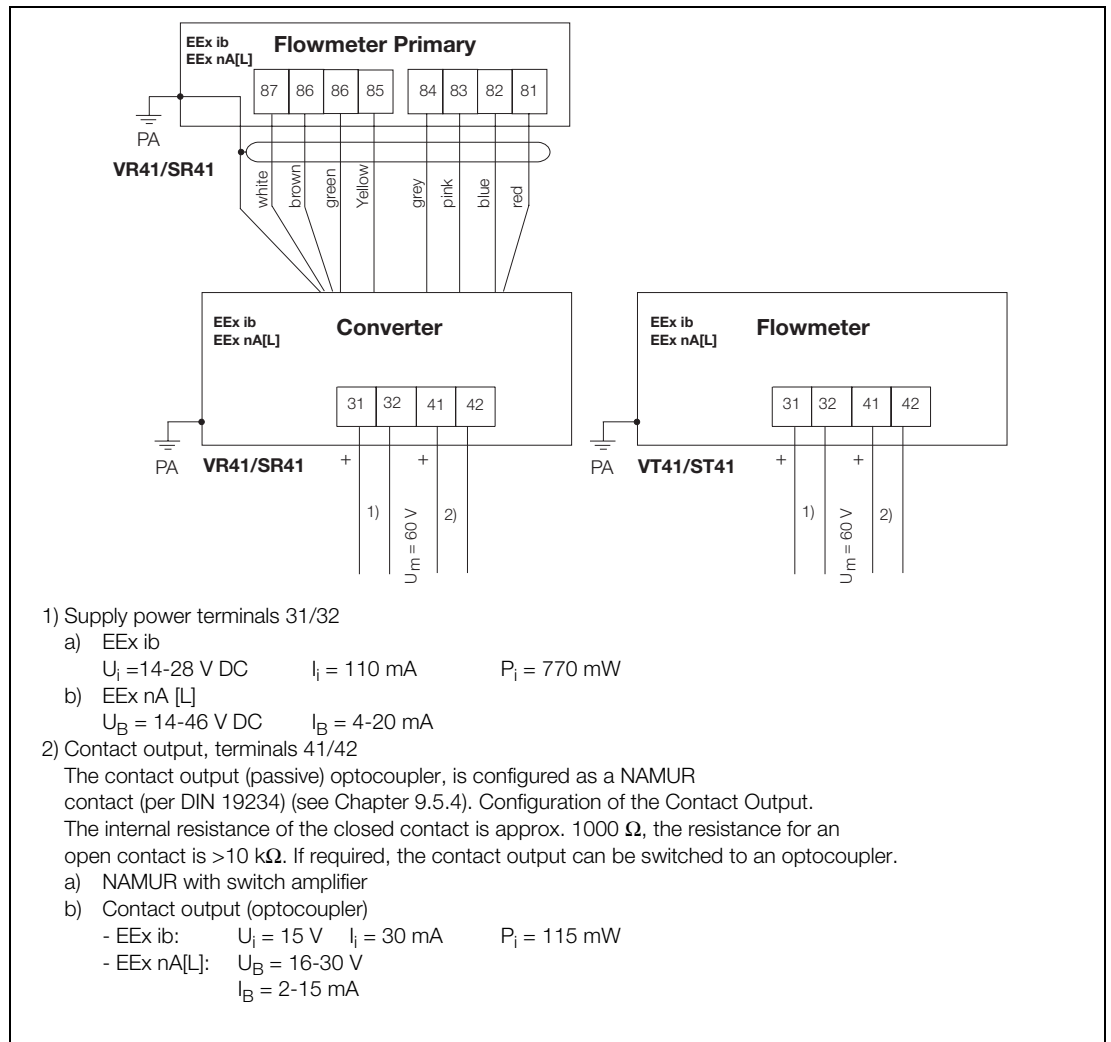

Fig. 33: Interconnection Diagram VT41/ST41 and VR41/SR41



The installation information in EN 60079-14 is to be observed.

At start-up, EN 50281-1-2 for use in areas with combustible dust is to be considered.

After the power is turned off, a delay of $t > 2$ minutes must be observed before opening the converter housing.

10.1.2 Terminals 31/32 / Supply Power or Supply Current (see also Chapter 6.1)

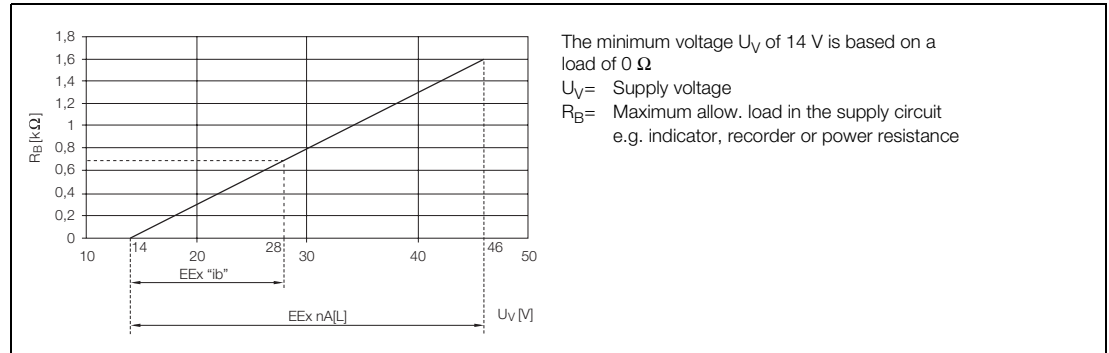

Fig. 34:

10.1.3 Ex-Approval Specifications VT41/ST41 / VR41/SR41

Supply circuit	Terminals 31,32
Ignition Type $U_m = 60 \text{ V}$	II 2G EEx ib IIC T4 / $T_{amb} = (-55 \text{ °C}) -20 \dots +70 \text{ °C}$ electrical connection: intrinsically safe $U_i = 28 \text{ V}$ $I_i = 110 \text{ mA}$ $P_i = 770 \text{ mW}$ effective internal capacitance: 14.6 nF effective internal capacitance to earth: 24.4 nF effective internal inductance: 0.27 mH
	II 3G EEx nA[L] IIC T4 / $T_{amb} = (-55 \text{ °C}) -20 \dots +70 \text{ °C}$ electrical connection: non-intrinsically safe $U_B = 14-46 \text{ V}$
	II 2D T 85 °C ... T_{med} IP67 / $T_{amb} = -20 \text{ °C} \dots +60 \text{ °C}$ electrical connection: intrinsically safe or non-intrinsically safe
Recommended Transmitter Power Supply	
ABB Automation	Contrans I V 17151-62
Digitable, MTL, Pepperl+Fuchs	various types
Contact output	terminals 41, 42
Ignition Type $U_m = 60 \text{ V}$	II 2G EEx ib IIC T4 electrical connection: intrinsically safe $U_i = 15 \text{ V}$ $I_i = 30 \text{ mA}$ $P_i = 115 \text{ mW}$ effective internal capacitance: 11 nF effective internal capacitance to earth: 19.6 nF effective internal inductance: 0.14 mH
	II 3G EEx nA[L] IIC T4 electrical connection: non-intrinsically safe $U_B = 16-30 \text{ V}$ $I_B = 2-15 \text{ mA}$
	II 2D T 85 °C ... T_{med} IP67 / $T_{amb} = -20 \text{ °C} \dots +60 \text{ °C}$ electrical connection: intrinsically safe or non-intrinsically safe
Recommended NAMUR Isolation Amplifier for EEx ib	
ABB Automation	V17131-51 ... 53, V17131-54 ... 56
Digitable, MTL, Pepperl+Fuchs	various types

10.1.4 Fluid Temperatures/Temperature Classes

For the supply circuit terminals 31, 32 and the contact output 41, 42 cables suitable for temperatures to T = 110 °C, can be used without restrictions.

Category 2G:

For cables, which are only suitable for temperatures to T = 80 °C, a shorting of both circuits during a fault condition should be considered, otherwise the restricted temperature ranges in the following table apply.

Category 2D/3G:

For cables, which are only suitable for temperatures to T = 80 °C, the restricted temperature ranges in the following table apply.

Ambient Temperature ²⁾ in [°C]	Max. Temperature at the Connection Cable Used Terminals 31/32, 41/42 [°C]	Max. Allow. Fluid Temperature [°C]
-20 to 70	110	280/400 ¹⁾
-20 to 70	80	160
-20 to 60		240
-20 to 55		280
-20 to 50		320 ¹⁾
-20 to 40		400 ¹⁾

- 1) Fluid temperatures >280 °C only with Vortex flowmeters FV4000
- 2) Allowable limits for the ambient temperature are dependent on the approvals and order (standard -20 °C)

Maximum Fluid Temperature	Temperature Class
130 °C	T4
195 °C	T3
290 °C	T2
400 °C	T1

10.1.5 Insulating the Flowmeter

The pipeline can be insulated to a thickness not exceeding 100 mm above its upper surface (Fig. 35).

Installation of Trace Heaters

Trace heaters may be installed if:

- they are rigidly mounted close to or around the pipeline
- they are embedded in the pipeline insulation, if used (max. thickness of 100 mm must be maintained).
- the max. resultant temperature of the trace heaters \leq the max. fluid temperature.

The Installation Regulations are to be maintained!

Assure that the installation of trace heaters does not have any adverse effect on the EMC-Protection, and does not add any additional vibrations.

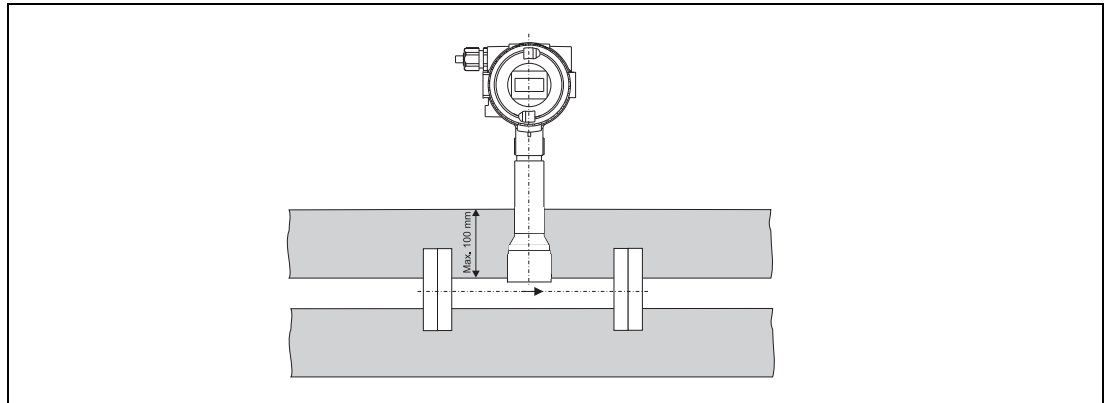

Fig. 35: Insulating the Flowmeter

10.1.6 Name plate

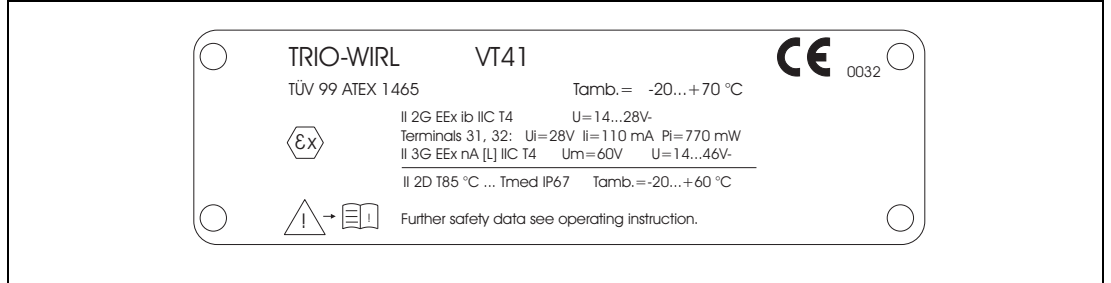

Fig. 36: EEx Intrinsically Safe

10.2 Design EEx „d“ / EEx „ib“ / EEx „n“
for VT42/ST42 and VR42/SR42 (4-20 mA/HART)



Operation in explosion hazardous areas is only permissible when the housing is completely closed

EC-Type Examination Certificate TÜV 00 ATEX 1521X

Identification:



- II 2G EEx d [ib] IIC T6
- II 2G EEx ib IIC T4
- II 3G EEx nA [L] IIC T4
- II 2D T 85 °C ... T_{med} IP67

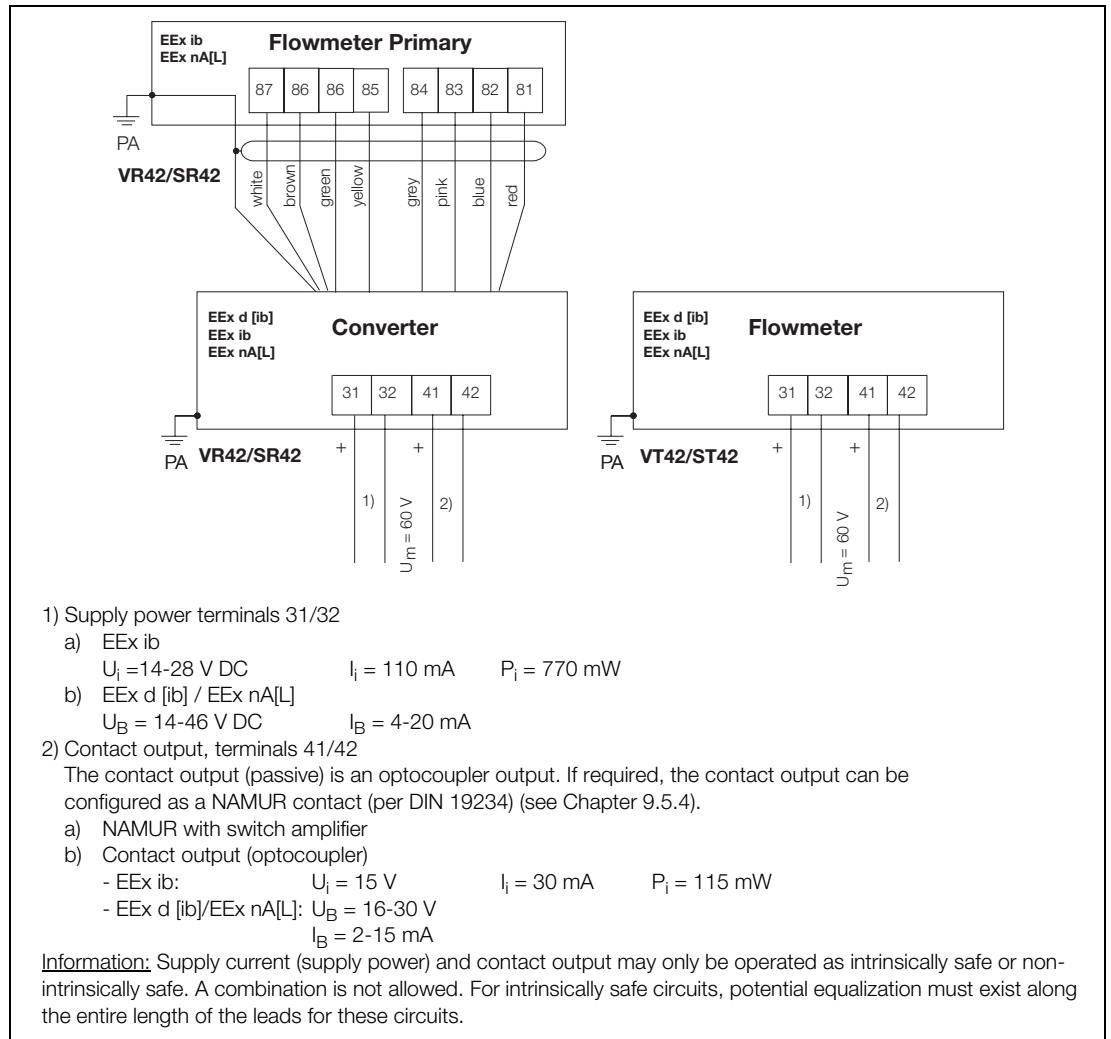

Fig. 37: Interconnection Diagram VT42/ST42 and VR42/SR42



The installation information in EN 60079-14 is to be observed.

At start-up, EN 50281-1-2 for use in areas with combustible dust is to be considered.

After the power is turned off, a delay of $t > 2$ minutes must be observed before opening the converter housing.

10.2.3 Fluid Temperatures/Temperatures Classes

For the supply circuit terminals 31, 32 and the contact output 41, 42 cables suitable for temperatures to T = 110 °C, can be used without restrictions.

Category 2G: EEx ib/intrinsically safe operation

For cables, which are only suitable for temperatures to T = 80 °C, a shorting of both circuits during a fault condition should be considered, otherwise the restricted temperature ranges in the following table apply.

Category 2D/3G and 2G: EEx d [ib]/flameproof operation

For cables, which are only suitable for temperatures to T = 80 °C, the restricted temperature ranges in the following table apply.

Ambient Temperature ²⁾ in [°C]	Max. Temperature at the Connection Cable Used Terminals 31/32, 41/42 [°C]	Max. Allow. Fluid Temperature [°C]
-20 to 60	110	280/400 ¹⁾
-20 to 60	80	240
-20 to 55		280
-20 to 50		320 ¹⁾
-20 to 40		400 ¹⁾

- 1) Fluid temperatures >280 °C only with Vortex flowmeters FV4000
- 2) Allowable limits for the ambient temperature are dependent on the approvals and order (standard -20 °C)

Ex-Design	Maximum Fluid Temperature	Temperature Class
EEx d [ib] IIC	80 °C	T6
	95 °C	T5
EEx ib IIC or EEx nA[L]	130 °C	T4
	195 °C	T3
	290 °C	T2
	400 °C	T1

10.2.4 Insulating the Flowmeter

The pipeline can be insulated to a thickness not exceeding 100 mm above its upper surface (Fig. 39).

Installation of Trace Heaters

Trace heaters may be installed if:

- they are rigidly mounted close to or around the pipeline
- they are embedded in the pipeline insulation, if used (max. thickness of 100 mm must be maintained).
- the max. resultant temperature of the trace heaters \leq the max. fluid temperature.

The Installation Regulations are to be maintained!

Assure that the installation of trace heaters does not have any adverse effect on the EMC-Protection, and does not add any additional vibrations.

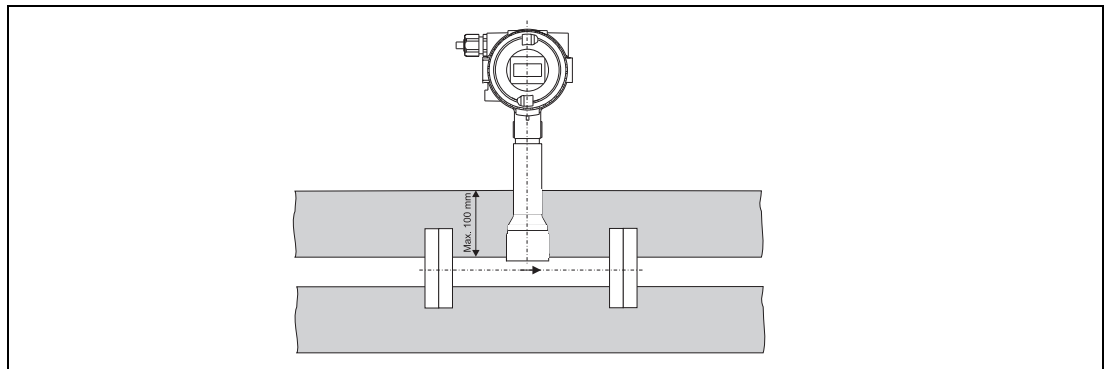

Fig. 39: Insulating the Flowmeter

10.2.5 Name plate

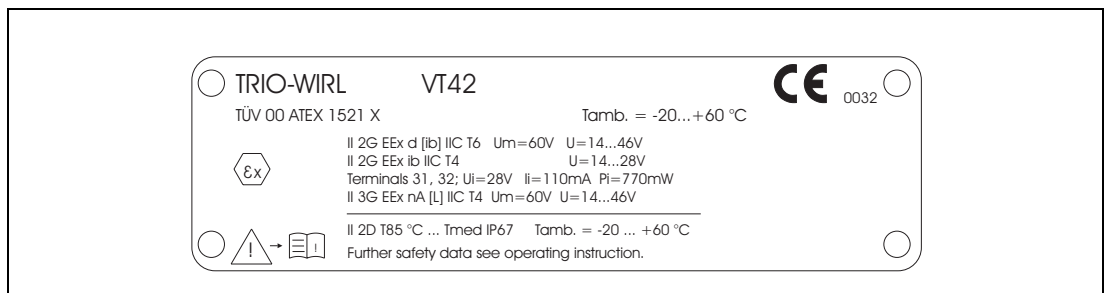

Fig. 40: EEx Flameproof

10.2.6 Special Installation Instructions for the Flameproof EEx „d“ Design

The electrical connections to the flowmeter are made using the cable connector installed on the instrument (see Fig. 41). Alternatively the connections to the flowmeter can also be made using an approved pipe fitting which incorporates a flame block (located immediately adjacent to the instrument. The installed cable connector is to be removed). The requirements in EN 50018 Sections 13.1 and 13.2 must be maintained. The installer Regulations EN60079-14 are to be considered when selecting the pipe fittings.

10.2.6.1 Connections Using the Pressure Tight Cable Connector

The outside diameter of the unshielded interconnection cable must be between 8.0 and 11.7 mm. After inserting the cable into the connector, the union nut is to be tightened to a torque of 32.5 Nm. In addition, the cable is to be secured by the stress relief clamp in the housing (see Fig. 41).

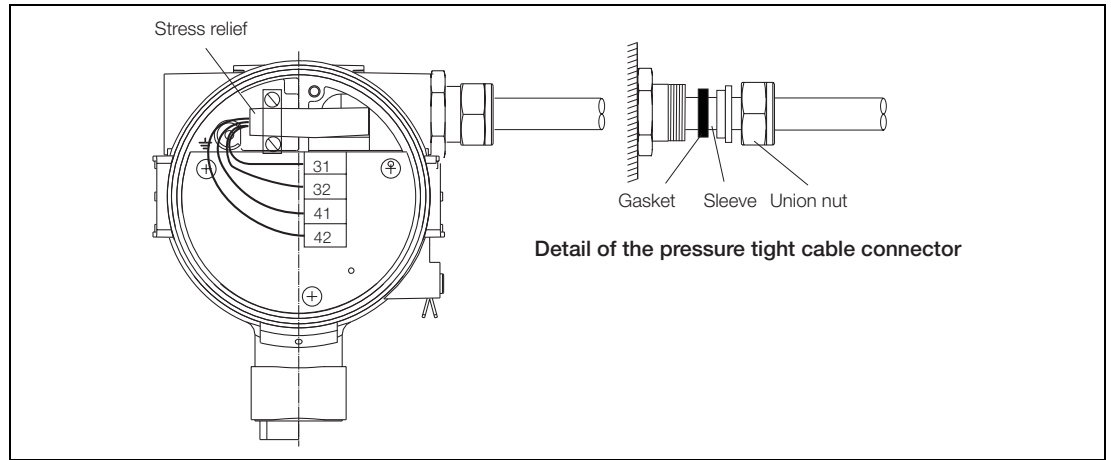

Fig. 41: Electrical Connections in the Flameproof Design

10.3 Design FM-Approval



Operation in explosion hazardous areas is only permissible when the housing is completely closed

FM-Revision Report Project ID 3017975

Identification

explosion proof	XP/Class I/Div 1/BCD/T4 Ta = 70 °C Type 4X
dust-ignition proof	DIP/Class II, III/Div 1/EFG/T4 Ta = 70 °C Type 4X
intrinsically safe	IS/Class I, II, III/Div 1 ABCDEFG/T4 Ta = 70 °C Entity Type 4X
non-incendive	NI/Class I/Div 2/ABCD/T4 Ta = 70 °C Type 4X
suitable	S/Class II, III/Div 2/FG/T4 Ta = 70 °C Type 4X

Entity see: SD-50-2651 (Fig. 43) parameters: $V_{max} = 28$, $I_{max} = 110$ mA, $P_i = 0.77$ W, $L_i = 0.27$ mH, $C_i = 14.6$ nF
Enclosure: Type 4X

10.3.1 Terminals 31/32
Supply Power or Supply Current (see also Chapter 6.1)

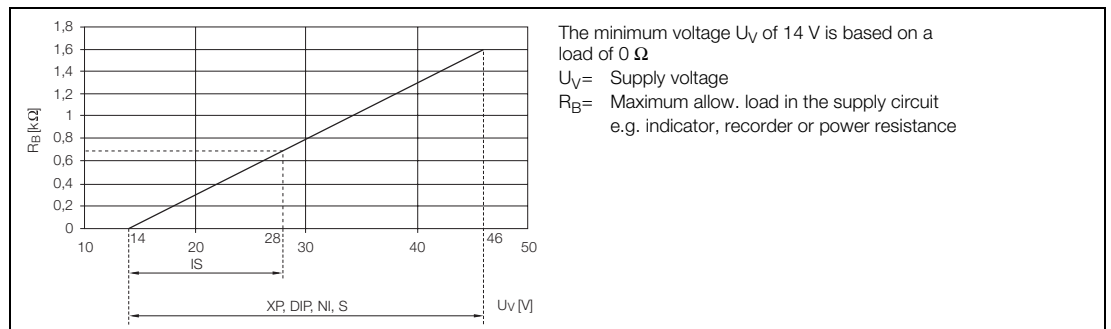

Fig. 42: Relationship: Supply Voltage / Load

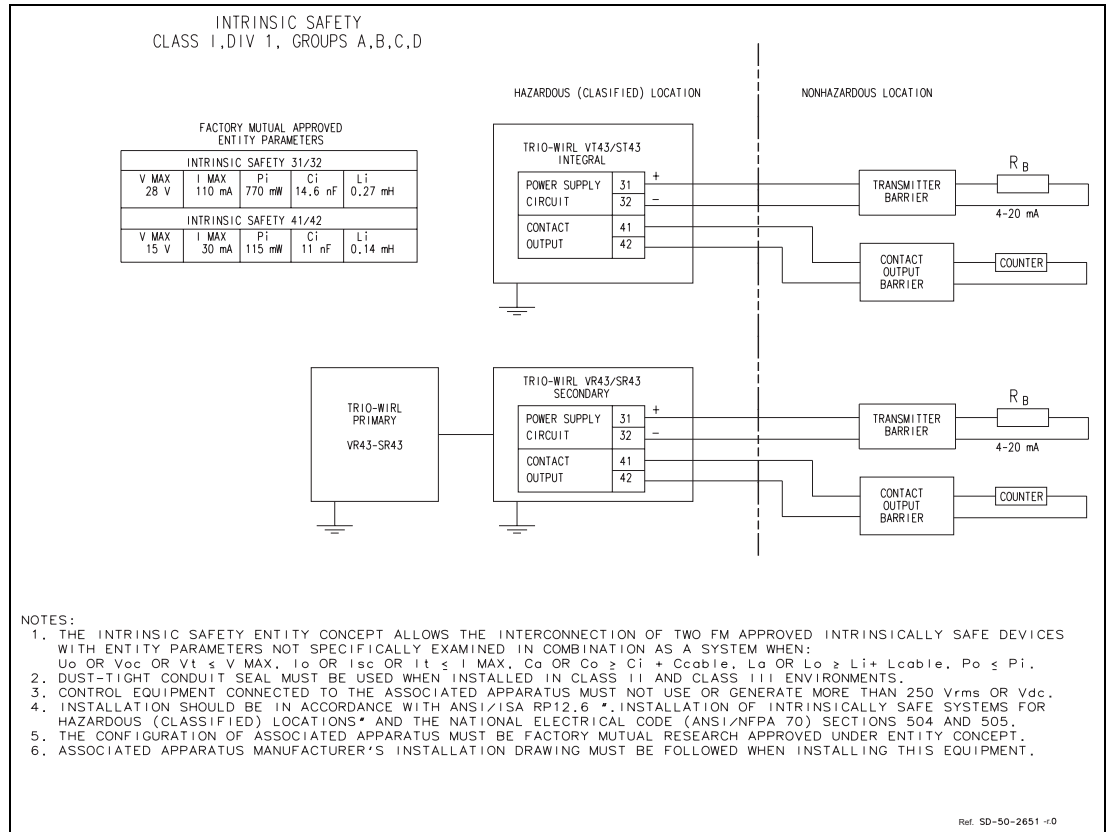

Fig. 43: Interconnection Diagram and Specifications VT/VR43 u. ST/SR43

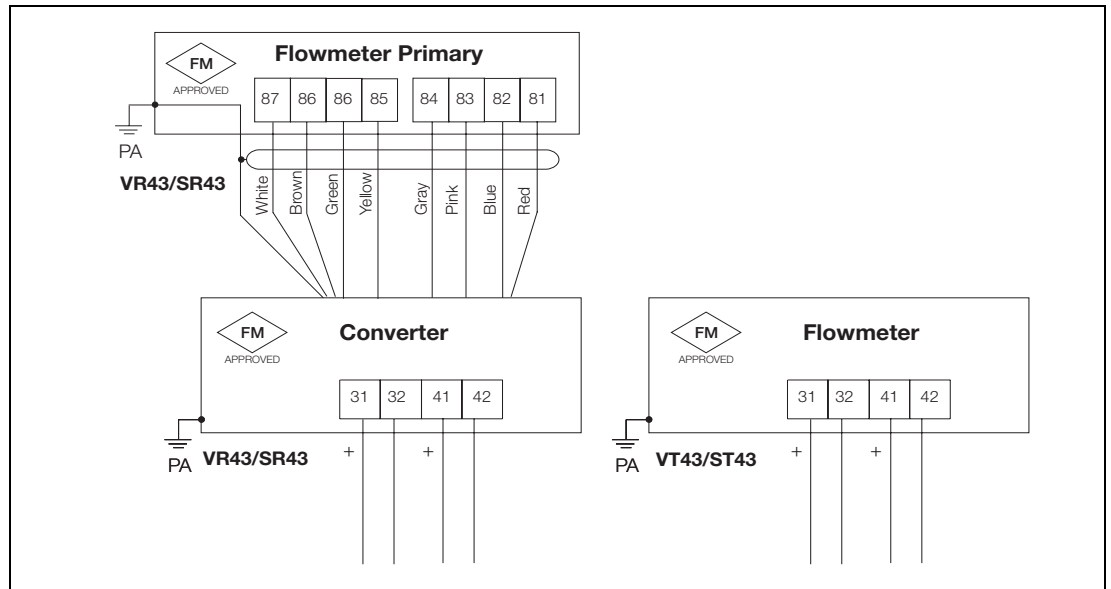

Fig. 44: Interconnection Diagram VR/SR43 and VT/ST43

10.3.2 Ex-Approval Specifications

Ambient temperature -20 to 70 °C

VT43/ST43; VR43/SR43

Supply Circuit terminals 31, 32

explosion proof	XP/Class I/Div 1/ BCD/T4 Ta = 70 °C Type 4X	U _B = 14-46 V
dust-ignition proof	DIP/Class II,III/Div 1/EFG/T4 Ta = 70 °C Type 4X	
intrinsically safe	IS/Class I, II,III/Div 1 ABCDEFG/T4 Ta = 70 °C Entity Type 4X	V _{max} = 28 V I _{max} = 110 mA P _i = 770 mW effective internal capacitance: C _i = 14.6 nF effective internal capacitance to earth: 24.4 nF effective internal inductance: L _i = 0.27 mH
non-incendive	NI/Class I/Div 2/ABCD/T4 Ta = 70 °C Type 4X	U _B = 14-46 V
suitable	S/Class II,III/Div 2/FG/T4 Ta = 70 °C Type 4X	

VT43/ST43; VR43/SR43

Contact Output terminals 41, 42

explosion proof	XP/Class I/Div 1/ BCD/T4 Ta = 70 °C Type 4X	U _B = 16-30 V I _B = 2-15 mA
dust-ignition proof	DIP/Class II,III/Div 1/EFG/T4 Ta = 70 °C Type 4X	
intrinsically safe	IS/Class I, II,III/Div 1 ABCDEFG/T4 Ta = 70 °C Entity Type 4X	V _{max} = 15 V I _{max} = 30 mA P _i = 115 mW effective internal capacitance: C _i = 11 nF effective internal capacitance to earth: 19.6 nF effective internal inductance: L _i = 0.14 mH
non-incendive	NI/II/2/ABCD/T4 Ta = 70 °C Type 4X	U _B = 16-30 V I _B = 2-15 mA
suitable	S/II,III/2/FG/T4 Ta = 70 °C Type 4X	

10.3.3 Fluid Temperatures/Temperature Classes

For the supply circuit terminals 31, 32 and the contact output 41, 42 cables suitable for temperatures to T = 110 °C, can be used without restrictions. For cables, which are only suitable for temperatures to T = 80 °C, the restricted temperature ranges in the following table apply.

Ambient Temperature in [°C]	Max. Temperature at the Connection Cable Used Terminals 31/32, 41/42 [°C]	Max. Allow. Fluid Temperature [°C]
-20 to 60	110	280/400 ¹⁾
-20 to 60	80	240
-20 to 55		280
-20 to 50		320 ¹⁾
-20 to 40		400 ¹⁾

1) Fluid temperatures >280 °C only with Vortex flowmeters FV4000

10.3.4 Insulating the Flowmeter

The pipeline can be insulated to a thickness not exceeding 100 mm above its upper surface (Fig. 45).

Installation of Trace Heaters

Trace heaters may be installed if:

- they are rigidly mounted close to or around the pipeline
- they are embedded in the pipeline insulation, if used (max. thickness of 100 mm must be maintained).
- the max. resultant temperature of the trace heaters ≤ the max. fluid temperature.

The Installation Regulations are to be maintained!

Assure that the installation of trace heaters does not have any adverse effect on the EMC-Protection, and does not add any additional vibrations.

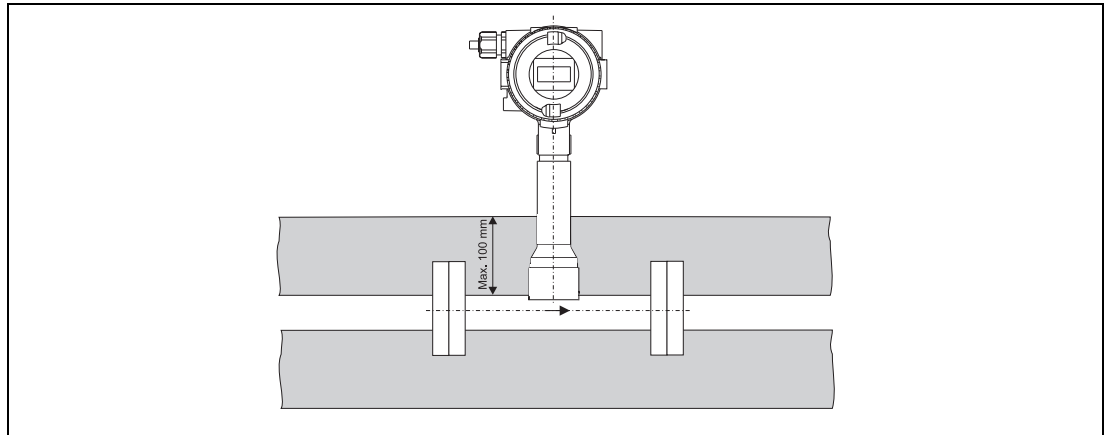

Fig. 45: Insulating the Flowmeter

10.3.5 Name plate

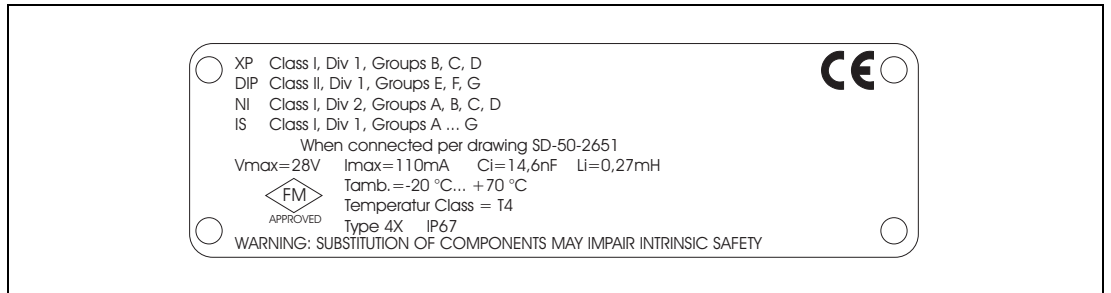

Fig. 46: Ex FM

10.3.6 Special Installation Information for Connecting the Flameproof FM-Design

The electrical interconnections can be made using an approved cable connector or using an approved pipe connector which incorporates a flame block (located immediately adjacent to the instrument. The installed cable connector is to be removed).

An approval certificate must be available for the pipe or cable connectors, the use of conventional cable and lead feedthrus and seal plugs is not permitted. Cable and pipe connectors are not included with the shipment of the instrument.

10.3.6.1 Opening the Flowmeter

After the power is turned, off a delay of $t > 2$ minutes must be observed before opening the pressure tight encapsulated housing.

11 Certificates

11.1 EC-Type Examination Certificate

Translated from German Original

SCHEDULE

EC-Type Examination Certificate No. TÜV 99 ATEX 1465

(13) Description of the Equipment

The flowmeter TRIO-WIRL Types VT41.; ST41.; VR41.; SR41. are utilized to meter the flowrate or the actual volume flow of steam, gases or liquids.

The allowable temperature range is -55°C to +70°C.

Electrical Specifications

Supply Power Circuit
(Terminals 31, 32)

Ignition Class Intrinsically Safe EEx ib IIC
Only for connection to a certified Intrinsically Safe circuit
 $U_i = 28\text{ V}$
 $I_i = 110\text{ mA}$
 $P_i = 770\text{ mW}$

Effective internal capacitance $C_i = 12.8\text{ nF}$
 Effective internal capacitance to PA $C_i = 24\text{ nF}$
 Effective internal inductance $L_i = 0.27\text{ mH}$

Contact Output
(Terminals 41, 42)

Ignition Class Intrinsically Safe EEx ib IIC
Only for connection to a certified Intrinsically Safe circuit
with the following maximum values:
 $U_i = 15\text{ V}$
 $I_i = 30\text{ mA}$
 $P_i = 115\text{ mW}$

Effective internal capacitance $C_i = 11.6\text{ nF}$
 Effective internal capacitance to PA $C_i = 19.6\text{ nF}$
 Effective internal inductance $L_i = 0.137\text{ mH}$

Types VR41. and SR41.

Sensor Circuit
Piezo Sensor
(Terminals 85, 86, 87)
and
PT100 Circuit
(Terminals 81, 82, 83, 84)

Ignition Class Intrinsically Safe EEx ib IIC
Maximum values:
 $U_o = 7.2\text{ V}$
 $I_o = 965\text{ mA}$

Page 2/3

Translated from German Original

TÜV CERT

EC-Type Examination Certificate



(1) Equipment or Protective Systems intended for use in potentially hazardous atmospheres - Directive 94/9/EC

(2) TÜV 99 ATEX 1465

(3) Equipment: Flowmeter TRIO-WIRL Types VT41.; ST41.; VR41.; SR41.

(4) Manufacturer: ABB Automation Products GmbH

(5) Address: D-37079 Göttingen, Dransfelder Straße 2, Germany

(6) The equipment or protective system and any acceptable variation thereto is specified in the schedule to this certificate and the documents therein to.

(7) The TÜV Hannover/Sachsen-Anhalt e.V., TÜV Certification Body No. 0032 in accordance with the Article 9 of the Council Directive of 23 March 1994 (94/9/EC) certifies that this equipment or protective system has been found to comply with the Essential Health and Safety Requirements relating to the design and construction of equipment and protective systems intended for use in potentially explosive atmospheres given in Annex II of the Directive.

(8) The examination and test results are recorded in the confidential Report No. 99/PX19790.

(9) Compliance with the Essential Health and Safety Requirements has been assured by the compliance with

EN 50 014:1997

EN 50 020:1994

(10) If the symbol "X" is placed after the certification number, it indicates that the equipment or protective system is subject to special conditions for safe use specified in the schedule to this certificate.

(11) This EC-Type Examination Certificate relates only to the design and construction of the specified equipment or protective system. If applicable, further requirements of this Directive apply to the manufacture and supply of this equipment or protective system.

(12) The markings for the equipment or protective system shall include the following:

 II G EEx ib IIC T4

TÜV Hannover/Sachsen-Anhalt e.V.
TÜV CERT-Zertifizierungsstelle
Am TÜV 1
D-30519 Hannover, Germany

Hannover, 08.03.1999

Head of the Certification Body

This EC-Type Examination Certificate may only be reproduced without any changes. Excerpts or changes require approval from the TÜV Hannover/Sachsen-Anhalt e.V.

Page 1/3

Translated from German Original

Schedule to EC-Type Examination Certificate No. TÜV 99 ATEX 1465

Types VT41. and ST41.

In these types the sensor circuits are internally intrinsically safe circuits.

(16) Test documentation are listed in Test Report No.: 99/PX19790.

(17) Special Conditions
None

(18) Basic Safety and Health requirements
None additionally

Page 3/3

Translated from German Original

1st SUPPLEMENT

to EC-Type Examination Certificate No. TÜV 99 ATEX 1465

of the Company: ABB Automation Products GmbH
Dransfelder Straße 2
D-37079 Göttingen, Germany

The flowmeters TRIO-WIRL Models VT41.; ST41.; VR41.; SR41. may now be manufactured and sold in accordance with the documentation listed in the Test Report. The revisions affect the internal construction and installations in Category 3. The symbol for this installation category is:

II 3 G EEx n [L] IIC T4 , Test Basis: pr EN 50 021:1996

The relationships between the instrument design, Temperature Class, maximum allowable ambient and fluid temperatures are listed in the following table.

Designed for	Allowable Ambient Temperature Range	Maximum Fluid Temperature	Temperature Class
EEx Ib IIC or EEx n [L] IIC	-55°C .. +70°C	130°C	T4
		195°C	T3
		290°C	T2
		400°C	T1

Electrical Specifications

Model	Circuit	EEx Ib IIC				EEx n [L] IIC		
		U _i [V]	I _i [mA]	P _i [mW]	C _i [nF]	C ₁₀ PA [nF]	L ₁ [mH]	U _n [V]
VT41./ST41. VR41./SR41.	Supply power circuit	28	110	770	14.6	24.4	0.27	60
	Contact output	15	30	115	11	19.6	0.14	
	Terminals 41, 42							
Model	Circuit	U _o [V]	I _o [mA]	P _o [W]				
VR41./SR41	Piezo-Sensor							
	Terminals 85, 86, 87 PT100-Circuit Terminals 81, 82, 83, 84	7.2	965	1.74				

(16) Test documentation are listed in Test Report No.: 00/PX02400.

(17) Special conditions : none

(18) Basic Safety and Health Requirements : none additionally

TÜV Hannover/Sachsen-Anhalt a.V.
Approval-Certification Body
Am TÜV 1
D-30518 Hannover, Germany
Sturwald
Head of the Certification Body

Hannover, 15 Feb 2000

Page 1/1



2nd Supplement to EU-Test Examination Certificate TÜV 99 ATEX 1465

Installation Information:

When the protection earth conductor (PE) is connected in the connection box of the flowmeter, assure that no dangerous potential differences can exist between the protection earth (PE) and the potential equalization in the explosion hazardous area.

The test documents are listed in Test Report No. 03YEX560599.

TÜV NORD CERT GmbH & Co. KG
 TÜV CERT-Certification Body
 Am TÜV 1
 D-30519 Hannover, Germany
 Tel.: +49 511 986-2555
 Fax: +49 511 986-2555

Hannover, 20 October 2003

The Director



Translated from German original

2nd SUPPLEMENT
 to
EC-Type Examination Certificate No. TÜV 99 ATEX 1465

Manufacturer: ABB Automation Products GmbH
 Dransfelder Straße 2
 D-37079 Göttingen, Germany

The TRIO WIRL flowmeters Types VT41, ST41, VR41, and SR41, may now also be manufactured in accordance with the test documents listed in the test report. The revisions affect the circuit boards, the use of the flowmeter in explosion hazardous areas containing flammable dust and the identification of and markings for the flowmeters.

The identification of the flowmeters will now be as follows:

Flowmeters FV4000 Types VT41, /VR41, and FS4000 Types ST41, /SR41.

The allowable ambient temperature range for use of the flowmeter in explosion hazardous areas containing flammable dust is -20°C ... +60°C.

For use of the flowmeter in explosion hazardous areas containing flammable dust, connections of intrinsically safe circuits in accordance with the electrical specifications in EC-Type Examination Certificate TÜV 99 ATEX 1465 or non-intrinsically safe circuits with $U_n = 60$ V is allowed.

The markings for the flowmeter used in explosion hazardous areas containing flammable dust

Flowmeters TRIO WIRL Types VT41, /ST41, /VR41, /SR41 and
 Flowmeters FV4000 Types VT41, /VR41, and FS4000 Types ST41, /SR41.:

⊕ II 2 D T85°C ... T_{Medium} IP67

Only converters for flowmeters TRIO WIRL Types VR41, /SR41, and
 converters for flowmeters FV4000 Types VR41, /FS4000 SR41.:

⊕ II 2 D T85°C IP67

Use in explosion hazardous areas with gases, steam or vapors

The markings for the flowmeters TRIO WIRL Types VT41, /ST41, /VR41, /SR41 and
 flowmeters FV4000 Types VT41, /VR41, and FS4000 Types ST41, /SR41, in areas, which require
 equipment for Category 3.

⊕ II 3 G EEx n A [L] IIC T1 ... T4

The remaining specifications remain unchanged.

Translation of German Original

EC-Type Examination Certificate

Equipment and Protective Systems intended for use in potentially hazardous atmospheres - Directive 94/9/EC

TÜV 00 ATEX 1521 X

- (1) Equipment: Flowmeter TRIO-WIRL Models VT42.; ST42.; VR42.; SR42.
- (2) Manufacturer: ABB Automation Products GmbH
- (3) Address: D-37079 Göttingen, Dransfelder Straße 2 Germany
- (4) The equipment or protective system and any acceptable variation thereto is specified in the schedule to this certificate and the documents therein to.
- (5) The TÜV Hannover/Sachsen-Anhalt e.V., TÜV Certification Body No. 0032 in accordance with the Article 9 of the Council Directive of 23 March 1994 (94/9/EC) certifies that this equipment or protective system has been found to comply with the Essential Health and Safety Requirements relating to the design and construction of equipment and protective systems intended for use in potentially explosive atmospheres given in Annex II of the Directive.
- (6) The examination and test results are included in the confidential Report No. 00/PX00300.
- (7) Compliance with the Essential Health and Safety Requirements has been assured by compliance with **EN 50 014:1997 EN 50 018:1995 EN 50 020:1984 pr EN 50 021:1996**
- (8) If the symbol "X" is placed after the certification number, it indicates that the equipment or protective system is subject to special conditions for safe use specified in the schedule to this certificate.
- (9) This EC-Type Test Examination Certificate relates only to the design and construction of the specified equipment or protective system. If applicable, further requirements of this directive apply to the manufacture and supply of this equipment or protective system.
- (10) The markings for the equipment or protective system shall include the:

II 2 G EEx d [ib] IIC T6, II 2 G EEx ib IIC T4
 or **II 3 G EEx n [L] IIC T4**

TÜV Hannover/Sachsen-Anhalt e.V.
TÜV CERT-Certification Body
Am TÜV 1
D-30519 Hannover, Germany

Sturweid
Head of the Certification Body

This EC-Type Examination Certificate may only be reproduced without any changes. Excerpts or changes require the approval of TÜV Hannover/Sachsen-Anhalt e.V.

Page 1/3

Translation of German Original

SCHEDULE

(14) EC-Type Examination Certificate No. TÜV 00 ATEX 1521 X

(15) Description of the Instrument

The flowmeters TRIO-WIRL Models VT42.; ST42.; VR42.; SR42. are used to measure the flowrate or volume at operating conditions of steam, gases or liquids.

The relationships between the instrument design, Temperature Class, max. allowable ambient and fluid temperatures are listed in the following tables:

Designed for	Allowable Ambient Temperature Range	Maximum Fluid Temperature	Temperature Class
EEx d [ib] IIC	-40°C .. 60°C	80°C	T6
		95°C	T5
		130°C	T4
		195°C	T3
		290°C	T2
		400°C	T1

Designed for	Allowable Ambient Temperature Range	Maximum Fluid Temperature	Temperature Class
EEx ib IIC or EEx n [L] IIC	-55°C .. 70°C	130°C	T4
		185°C	T3
		280°C	T2
		400°C	T1

Electrical Specifications

The allowable maximum values as a function of the Model No. and the design are listed in the following Table:

Model	Designed for EEx ib IIC	U _i [V]	I _i [mA]	P _i [mW]	C _i [nF]	C _i to PA [nF]	L _i [mH]	Designed for EEx d [ib] IIC or EEx n [L] IIC
VT42.; ST42.; VR42.; SR42.	Supply power circuit Terminals 31, 32	28	110	770	14.6	24.4	0.27	U _m = 60 V
	Contact output Terminals 41, 42	15	30	115	11	19.6	0.14	U _m = 60 V
Model	Designed for EEx ib IIC	U _i [V]	I _i [mA]	P _i [W]				
VR42., SR42., Internal circuit	Picco-Sensor Terminals 85, 86, 87 PT100-circuit Terminals 81, 82, 83, 84	7.2	965	1.74				

Page 2/3

Translation of German Original

Schedule to EC-Type Examination Certificate No. TÜV 00 ATEX 1521 X

(16) Test documents are listed in Test Report No.: 00/PX00300.

(17) Special Conditions

The supply power and current output circuits mentioned in the tables may be operated only as intrinsically safe or as non-intrinsically safe. A combination is not permissible. For intrinsically safe circuits potential equalization must be established along the entire length of these circuits.

(18) Essential Health and Safety Requirements

None additional

Page 3/3



Translated from German original

1st SUPPLEMENT
to
EC-Type Examination Certificate No. TÜV 00 ATEX 1521 X

Manufacturer: ABB Automation Products GmbH
Dransfelder Straße 2
D-37079 Göttingen, Germany

The TRIO WIRL flowmeter Types VT42., ST42., VR42. and SR42. may now also be manufactured in accordance with the test documents listed in the test report. The revisions affect the circuit boards, the use of the flowmeter in explosion hazardous areas containing flammable dust and the identification of and markings for the flowmeters.

The identification of the flowmeters will now be as follows:

Flowmeter FV4000 Types VT42. / VR42. and FS4000 Types ST42. / SR42.

The allowable ambient temperature range for use of the flowmeter in explosion hazardous areas containing flammable dust is -20°C ... + 60°C.

For use of the flowmeter in explosion hazardous areas containing flammable dust, connections of intrinsically safe circuits in accordance with the electrical specifications in EC-Type Examination Certificate TÜV 00 ATEX 1521 X or non-intrinsically safe circuits with $U_m = 60 V$ is allowed.

The markings for the flowmeter used in explosion hazardous areas containing flammable dust

Flowmeters TRIO WIRL Types VT42. / ST42. / VR42. / SR42 and
Flowmeters FV4000 Types VT42. / VR42. and FS4000 Types ST42. / SR42. :

Ⓔ II 2 D T85°C ... T_{Meq,un} IP67

Only converters for flowmeters TRIO WIRL Types VR42. / SR42. and
converters for flowmeters FV4000 Types VR42. / FS4000 SR42. :

Ⓔ II 2 D T85°C IP67

Use in explosion hazardous areas with gases, steam or vapors

The markings for the flowmeters TRIO WIRL Types VT42. / ST42. / VR42. / SR42. and
flowmeters FV4000 Types VT42. / VR42. and FS4000 Types ST42. / SR42. in areas, which require
equipment for Category 3.

Ⓔ II 3 G EEx n A [I] IIC T1 ... T4



1st Supplement to EC-Type Examination Certificate TÜV 00 ATEX 1521 X

Special Conditions:

- The supply power and the contact output specified in the table may only be operated as intrinsically safe or non-intrinsically safe circuits. A combination is not permissible. Potential equalization must exist along the entire circuit path for intrinsically safe circuits.
- When the protection earth conductor (PE) is connected in the connection box of the flowmeter, assure that no dangerous potential differences can exist between the protection earth (PE) and the potential equalization in the explosion hazardous area.

The remaining specifications remain unchanged.

The test documents are listed in Test Report No. 03YEX550600.

Hannover, 20 October 2003

TÜV NORD CERT GmbH & Co. KG
TÜV CERT-Certification Body
Am TÜV 1
D-37199 Hannover, Germany
Tel.: 0511 986-1470
Fax: 0511 986-2555

The Director

11.2 EC-Certificate of Compliance







EG-Konformitätserklärung
EC-Certificate of Compliance

Hiermit bestätigen wir die Übereinstimmung der
Herewith we confirm that our

TRIO-WIRL Durchflußmesser
TRIO-WIRL Flowmeter

Modell VT41.; ST41.; VR41.; SR41. FV4000/FS4000
Model VT41.; ST41.; VR41.; SR41. FV4000/FS4000

mit den grundlegenden Sicherheits- und Gesundheitsanforderungen gem. der Richtlinie 94/9/EG des Rates der Europäischen Gemeinschaft. Die Sicherheits- und Installationshinweise der Produktdokumentation sind zu beachten.
are in compliance with the Essential Health and Safety Requirements with refer to the council directives 94/9/EC of the European Community. The safety and installation requirements of the product documentation must be observed.

Die TRIO-WIRL Durchflußmesser dienen zur Messung des Durchflusses von Gasen, Dämpfen und Flüssigkeiten.
The TRIO-WIRL Flowmeters are utilized to meter the flowrate of gases, steam or liquids.

EG-Baumusterprüfbescheinigung: TÜV 99 ATEX 1465
EC-Type Examination Certificate:

Benannte Stelle: TÜV Hannover/Sachsen-Anhalt e.V., Kennnummer 0032
Notified Body:

Geräte-Kennzeichnung: II 2G EEx ib IIC T4 II 2D T85°C... T_{Medium} IP67
Apparatus code: II 3G EEx n A [L] IIC T4

Sicherheitstechnische Daten: siehe EG-Baumusterprüfbescheinigung TÜV 99 ATEX 1465
Safety values: refer to EC-Type Examination Certificate TÜV 99 ATEX 1465

Angewandte Normen: EN 50 014: 1997 EN 50 020: 1994
Standards: EN 50 021: 1999 EN 50 281-1-1: 1998

Göttingen, 28. Oktober 2003

Unterschrift / Signature

BZ-13-8010, Rev.3, 0234

ABB Automation Products GmbH

Prüfstelle: 2 D-37076 Göttingen D-37079 Göttingen
Beauftragter: 2 D-37076 Göttingen D-37079 Göttingen
Präsident: 2 D-37076 Göttingen D-37079 Göttingen
Technische Leitung: 2 D-37076 Göttingen D-37079 Göttingen
Internet: <http://www.abbc.com>

Vorstand des Aufsichtsrates: Vorsitz des Aufsichtsrates: Berndt von Arnim
Geschäftsführung: Hans-Joachim Böhme (Vorsitz)
Joachim Braun
Eckhard Frensch
Dr. Peter Frensch

Bankverbindung - Prüfamt: Commerzbank AG Frankfurt
Konto: 558 052 200
BLZ: 251 205 100







EG-Konformitätserklärung
EC-Certificate of Compliance

Hiermit bestätigen wir die Übereinstimmung der
Herewith we confirm that our

TRIO-WIRL Durchflußmesser
TRIO-WIRL Flowmeter

Modell VT42.; ST42.; VR42.; SR42. FV4000/FS4000
Model VT42.; ST42.; VR42.; SR42. FV4000/FS4000

mit den grundlegenden Sicherheits- und Gesundheitsanforderungen gem. der Richtlinie 94/9/EG des Rates der Europäischen Gemeinschaft. Die Sicherheits- und Installationshinweise der Produktdokumentation sind zu beachten.
are in compliance with the Essential Health and Safety Requirements with refer to the council directives 94/9/EC of the European Community. The safety and installation requirements of the product documentation must be observed.

Die TRIO-WIRL Durchflußmesser dienen zur Messung des Durchflusses von Gasen, Dämpfen und Flüssigkeiten.
The TRIO-WIRL Flowmeters are utilized to meter the flowrate of gases, steam or liquids.

EG-Baumusterprüfbescheinigung: TÜV 00 ATEX 1521 X
EC-Type Examination Certificate:

Benannte Stelle: TÜV Hannover/Sachsen-Anhalt e.V., Kennnummer 0032
Notified Body:

Geräte-Kennzeichnung: II 2G EEx d [ib] IIC T6 II 2D T85°C... T_{Medium} IP67
Apparatus code: II 3G EEx n A [L] IIC T4

Sicherheitstechnische Daten: siehe EG-Baumusterprüfbescheinigung TÜV 00 ATEX 1521 X
Safety values: refer to EC-Type Examination Certificate TÜV 00 ATEX 1521 X

Angewandte Normen: EN 50 014: 1997 EN 50 018: 1995 EN 50 020: 1994
Standards: EN 50 021: 1999 EN 50 281-1-1: 1998

Göttingen, 28. Oktober 2003

Unterschrift / Signature

BZ-13-8011, Rev.2, 0234

ABB Automation Products GmbH

Prüfstelle: 2 D-37076 Göttingen D-37079 Göttingen
Beauftragter: 2 D-37076 Göttingen D-37079 Göttingen
Präsident: 2 D-37076 Göttingen D-37079 Göttingen
Technische Leitung: 2 D-37076 Göttingen D-37079 Göttingen
Internet: <http://www.abbc.com>

Vorstand des Aufsichtsrates: Vorsitz des Aufsichtsrates: Berndt von Arnim
Geschäftsführung: Hans-Joachim Böhme (Vorsitz)
Joachim Braun
Eckhard Frensch
Dr. Peter Frensch

Bankverbindung - Prüfamt: Commerzbank AG Frankfurt
Konto: 558 052 200
BLZ: 251 205 100

The Industrial^{IT} wordmark and all mentioned product names in the form XXXXX^{IT} are registered or pending trademarks of ABB.

ABB has Sales & Customer Support expertise in over 100 countries worldwide.

www.abb.com

The Company's policy is one of continuous product improvement and the right is reserved to modify the information contained herein without notice.

Printed in the Fed. Rep. of Germany (03.04)

© ABB 2004



ABB Ltd.

Oldends Lane, Stonehouse
Gloucestershire, GL 10 3TA
UK
Phone: +44(0)1453 826661
Fax: +44(0)1453 829671

ABB Inc.

125 E. County Line Road
Warminster, PA 18974
USA
Phone: +1 215 674 6000
Fax: +1 215 674 7183

ABB Automation Products GmbH

Dransfelder Str. 2
37079 Göttingen
GERMANY
Phone: +49 551 905-534
Fax: +49 551 905-555

CCC-support.deapr@de.abb.com