

Received 5/92

Price \$ 5.00

GARDNER-DENVER®

13-8-609
1st Edition

**ELECTRA-SCREW® STATIONARY
BASE-MOUNTED & TANK-MOUNTED
COMPRESSORS**

MODELS

EBE_DD	-	15 HP
EBE_ED	-	20 HP
EBE_FD	-	25 HP
EBE_GD	-	30 HP

**OPERATING AND
SERVICE MANUAL**

**COOPER**

**Gardner-Denver
Industrial Machinery**

**MAINTAIN COMPRESSOR RELIABILITY AND PERFORMANCE WITH
GENUINE GARDNER-DENVER AND JOY COMPRESSOR
PARTS AND SUPPORT SERVICES**

Gardner-Denver and Joy Compressor genuine parts, engineered to original tolerances, are designed for optimum dependability --- specifically for Gardner-Denver and Joy compressor systems. Design and material innovations are the result of years of experience with hundreds of different compressor applications. Reliability in materials and quality assurance are incorporated in our genuine replacement parts.

Your authorized Gardner-Denver and Joy Compressor distributor offers all the backup you'll need. A worldwide network of authorized distributors provides the finest product support in the air compressor industry.

Your local authorized distributor maintains a large inventory of genuine parts and he is backed up for emergency parts by direct access to the Gardner-Denver Industrial Machinery Master Distribution Center (MDC) in Memphis, Tennessee.

Your authorized distributor can support your Gardner-Denver or Joy air compressor with these

services:

1. Trained parts specialists to assist you in selecting the correct replacement parts.
2. Factory warranted new and remanufactured rotary screw air ends. Most popular model remanufactured air ends are maintained in stock at MDC for purchase on an exchange basic with liberal core credit available for the replacement unit.
3. A full line of factory tested AEON™ compressor lubricants specifically formulated for use in Gardner-Denver and Joy compressors.
4. Repair and maintenance kits designed with the necessary parts to simplify servicing your compressor.

Authorized distributor service technicians are factory-trained and skilled in compressor maintenance and repair. They are ready to respond and assist you by providing fast, expert maintenance and repair services.

For the location of your local authorized Gardner-Denver and Joy Air Compressor distributor refer to the yellow pages of your phone directory or contact:

**Distribution Center:
Gardner-Denver
Industrial Machinery Division
Master Distribution Center
5585 East Shelby Drive
Memphis, TN 38115
Phone: (901) 363-6100
Fax: (901) 393-1095**

**Factory:
Gardner-Denver
Industrial Machinery Division
1800 Gardner Expressway
Quincy, IL 62301
Phone: (217) 222-5400
Fax: (217) 2235897**

FOREWARD

Gardner-Denver Electra-Screw® compressors are the result of advanced engineering and skilled manufacturing. To be assured of receiving maximum service from this machine the owner must exercise care in its operation and maintenance. This book is written to give the operator and maintenance department essential information for day-to-day operation, maintenance and adjustment. Careful adherence to these instructions will result in economical operation and minimum downtime.

DANGER

Failure to observe a DANGER notice could result in injury to, or death of personnel.

WARNING

Failure to observe a WARNING notice could result in damage to equipment.

CAUTION

CAUTION notices set forth general reminders of good safety practice, or direct attention to unsafe practices.

NOTE

Information furnished in a NOTE will include general information or the highlights of a procedure.

This book covers the following models:

HP	PSIG	Air Cooled
15	100, 125	EBE_DD
20	100, 125, 150	EBE_ED
25	100, 125, 150, 175	EBE_FD
30	100, 125, 150, 175	EBE_GD

TABLE OF CONTENTS

GENERAL INFORMATION.....	SECTION 1
INSTALLATION.....	SECTION 2
STARTING AND OPERATING PROCEDURES	SECTION 3
CONTROLS AND INSTRUMENTS.....	SECTION 4
LUBRICATION, OIL COOLER, OIL FILTER AND SEPARATOR	SECTION 5
AIR FILTERS	SECTION 6
BELT DRIVE.....	SECTION 7
MAINTENANCE SCHEDULE	SECTION 8
TROUBLE SHOOTING.....	SECTION 9

INDEX

NOTE: Numbers preceding dash are Section Numbers -- Numbers following dash are Page Numbers

Air Control Components	4-2	Lifting Unit	2-1
Air Cooled Unit Installation.....	2-1	Location	2-1
Air Filter Element Life.....	6-2	Lubricant, Addition of Oil Between Changes	5-2
Air Filter Element Servicing Instructions.....	6-1	Lubricant, Changing Type of Oil.....	5-1
AIR FILTER (SECTION 6)	6-1	Lubricant, Draining and Cleaning System.....	5-3
Air Flow Quantity	2-1	Lubricant, Oil Specifications	5-1
Air/Oil Flow Diagram.....	5-1	Lubricant Change Interval.....	5-3
Auto Sentry S - Auto Lag Button.....	4-3	LUBRICATION, OIL COOLER, OIL FILTER & SEPARATOR (SECTION 5)	5-1
Auto Sentry S - Auto Lead Button.....	4-3	MAINTENANCE SCHEDULE (SECTION 8)	8-1
Auto Sentry S - Constant Run Button	4-3	Minimum Pressure/Check Valve	4-2
Auto Sentry S - Control Pad Diagram.....	4-8	Moisture in the Oil System	5-3
Auto Sentry S - Hourmeter	4-3	Motor Lubrication	2-4
Auto Sentry S - Keypad	4-3	Motor Protection Devices	4-1
Auto Sentry S - Lead-Lag Operation.....	4-6	Oil Cooler - Radiator Type	5-4
Auto Sentry S - Programming and Set-Up Instructions	4-4	Oil Filter.....	5-4
Auto Sentry S - Stop/Reset Button	4-3	Oil Level Gauge	5-3
Basic Information.....	1-1	Oil Reservoir	5-4
BELT DRIVE (SECTION 7)	7-1	Oil Reservoir Drain	2-2
Blowdown Valve Control	4-2	Oil Separator	5-5
Blowdown Valve Piping.....	2-3	Oil Separator - Pressure Differential Gauging	5-5
Cold Weather Operation.....	2-2	Oil Separator - Removal.....	5-5
CONTROLS AND INSTRUMENTS (SECTION 4)	4-1	Oil System Check	5-6
Decals	1-5	Operating Air Pressure Adjustment.....	4-6
Discharge Service Line.....	2-3	Outline Drawings.....	1-2
Electrical Wiring.....	2-4	Pressure and Temperature Digital Readouts	4-4
Enclosure	2-2	Prestart-Up Instructions	3-1
Error Messages - Definitions	4-4	Protective Devices and Shutdown	4-1
Filling Oil Reservoir	5-3	Regreasing Interval	2-5
Foundation	2-1	Relief Valve	4-1
GENERAL INFORMATION (SECTION 1)	1-1	Safety Precautions	1-4
High Temperature Operation	5-1	Separator Differential Pressure Shutdown.....	4-1
High Temperature Shutdown.....	4-1	STARTING & OPERATING PROCEDURES (SECTION 3)	3-1
Inlet Line	2-3	Starting The Unit, Cold.....	3-2
Inlet Valve Control.....	4-2	Starting The Unit, Hot.....	3-2
INSTALLATION (SECTION 2)	2-1	Stopping The Unit	3-2
Instruments	4-2	Subtractive Pilot	4-6
LED - Change Air Filter.....	4-4	Thermostatic Mixing Valve	5-4
LED - Change Separator.....	4-4	TROUBLE SHOOTING (SECTION 9)	9-1
LED - High Air Temperature	4-3	Wiring Diagram.....	4-9
LED - Motor Overload.....	4-3		

SECTION 1 GENERAL INFORMATION

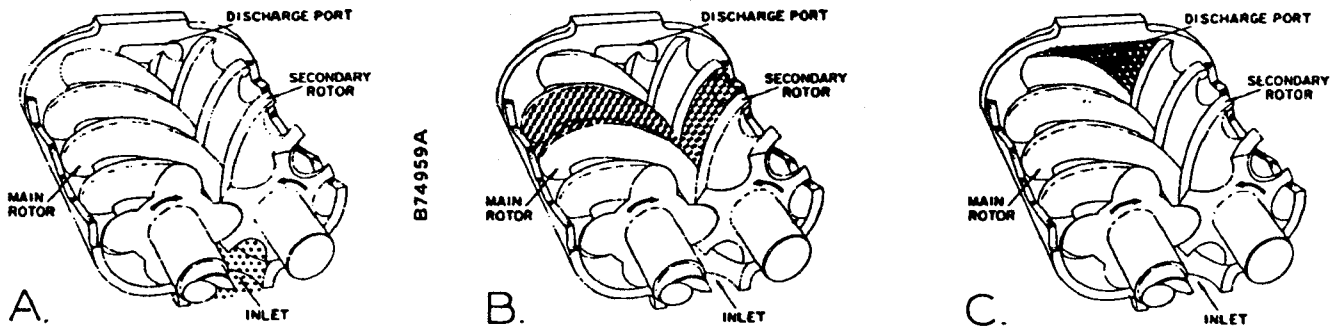

FIGURE 1-1 - COMPRESSION CYCLE

COMPRESSOR - The Gardner-Denver® compressor is a single stage, positive displacement rotary machine using meshing helical rotors to effect compression. Both rotors are supported between high capacity roller bearings located outside the compression chamber. Single width cylindrical roller bearings are used at the inlet end of the rotors to carry part of the radial loads. Tapered roller bearings at the discharge end locate each rotor axially and carry all thrust loads and the remainder of the radial loads.

COMPRESSION PRINCIPLE (Figure 1-1) - Compression is accomplished by the main and secondary rotors synchronously meshing in a one-piece cylinder. The main rotor has four (4) helical lobes 90° apart. The secondary rotor has six (6) matching helical grooves 60° apart to allow meshing with main rotor lobes.

The air inlet port is located on top of the compressor cylinder near the drive shaft end. The discharge port is near the bottom at the opposite end of the compressor cylinder. *Figure 1-1 is an inverted view to show inlet and discharge ports.* The compression cycle begins as the rotors unmesh at the inlet port and air is drawn into the cavity between the main rotor lobes and the secondary rotor grooves (A). When the rotors pass the inlet port cutoff, air is trapped in the interlobe cavity and flows axially with the meshing rotors (B). As meshing continues, more of the main rotor lobe enters the secondary rotor groove, normal volume is reduced and pressure increases.

Oil is injected into the cylinder to remove the heat of compression and seal internal clearances. Volume reduction and pressure increase continues until the air/oil mixture trapped in the interlobe cavity by the rotors passes the discharge port and is released to the oil reservoir (C). Each rotor cavity follows the same "fill-compress-discharge" cycle in rapid succession to produce a discharge air flow that is continuous, smooth and shock free.

AIR FLOW IN THE COMPRESSOR SYSTEM (Figure 1-5) - Air enters the air filter and passes through the inlet unloader valve and on into the compression chamber where oil is injected into the air. After compression, the air/oil mixture passes into the oil reservoir where most of the entrained oil is removed by velocity change and impingement and drops back into the reservoir. The air and remaining oil then passes through piping and the air/oil separator. The air then passes through the minimum pressure/check valve, the aftercooler and the moisture separator and into the plant air lines.

LUBRICATION, COOLING AND SEALING - Oil is forced by air pressure from the oil reservoir through the oil cooler, thermostatic mixing valve, and oil filter and discharge into the compressor main oil gallery. A portion of the oil is directed through internal passages to the bearings, gears and shaft oil seal. The balance of the oil is injected directly into the compression chamber to remove heat of compression, seal internal clearances and lubricate the rotors.

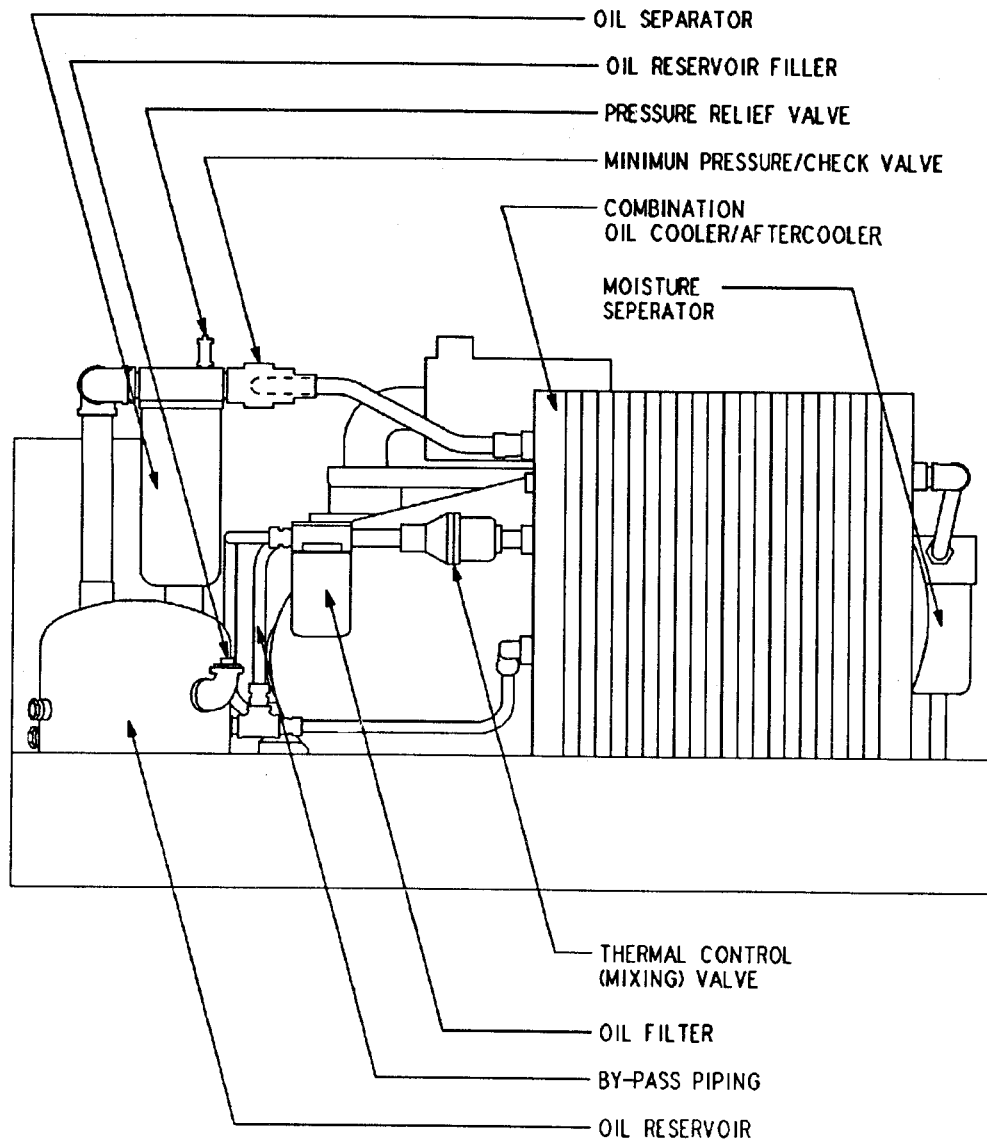

FIGURE 2-1

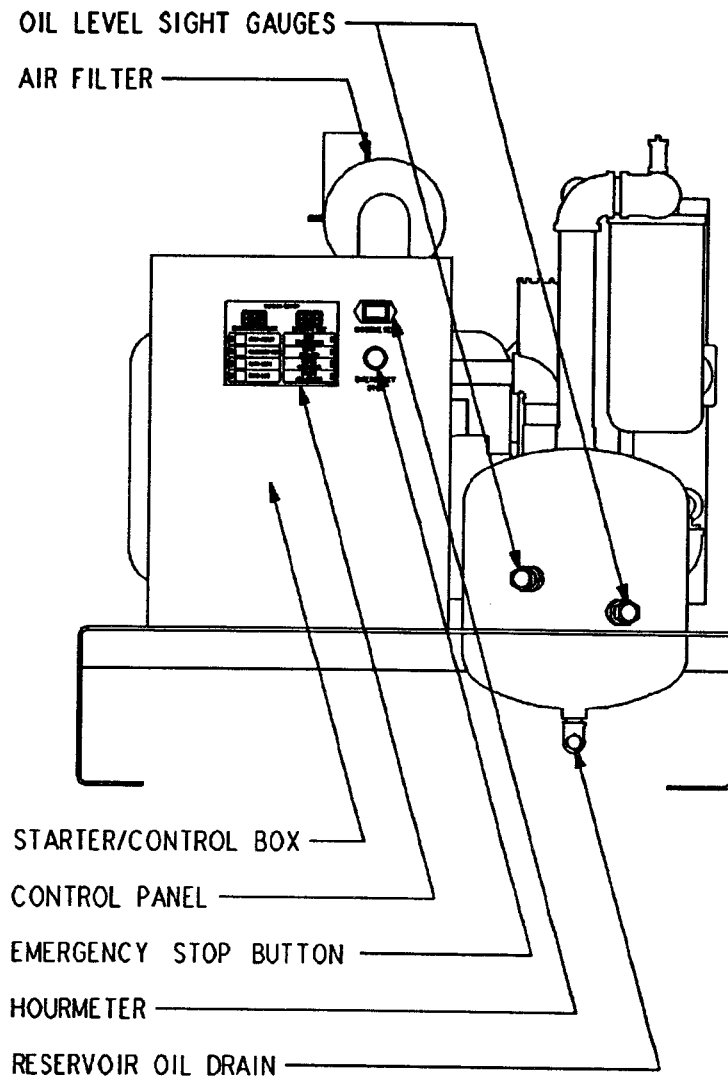

FIGURE 3-1

SAFETY PRECAUTIONS

Safety is everybody's business and is based on your use of good common sense. All situations or circumstances cannot always be predicted and covered by established rules. Therefore, use your past experience, watch out for safety hazards and be cautious. Some general safety precautions are given below:

WARNING

Failure to observe these notices could result in damage to equipment.

- **Stop the unit** if any repairs or adjustments on or around the compressor are required.
- **Disconnect the compressor** unit from its power source before working on the unit - this machine is automatically controlled and may start at any time.
- **An Excess Flow Valve** should be on all compressed air supply hoses exceeding 1/2 inch inside diameter. (OSHA Regulation, Section 1518.302)
- **Do not exceed the rated maximum pressure values** shown on the nameplate.
- **Do not operate unit** if safety devices are not operating properly. Check periodically. Never bypass safety devices.

DANGER

Failure to observe these notices could result in injury to or death of personnel.

- **Keep fingers and clothing away** from revolving fan, drive coupling, etc.
- **Do not use the air discharge** from this unit for breathing - not suitable for human consumption.
- **Do not loosen or remove** the oil filler plug, drain plugs, covers, the thermostatic mixing valve or break any connections, etc. in the compressor air or oil system until the unit is shut down and the air pressure has been relieved.
- **Electrical shock** can and may be fatal.
- **Compressor unit must be grounded** in accordance with the National Electrical Code. A ground jumper equal in size to the equipment ground conductor must be used to connect the compressor motor base to the unit base.
- **Fan motors must remain grounded** to the main base through the starter mounting panel in accordance with the National Electrical Code.
- **Open main disconnect switch** before working on the control.
- **Disconnect the compressor** unit from its power source before working on the unit - this machine is automatically controlled and may start at any time.

DECALS

⚠ DANGER



DISCHARGE AIR USED FOR BREATHING WILL CAUSE SEVERE INJURY OR DEATH. CONSULT FILTRATION SPECIALIST FOR ADDITIONAL FILTRATION AND TREATMENT EQUIPMENT TO MEET HEALTH AND SAFETY REGULATIONS.

21EAG0077

⚠ DANGER

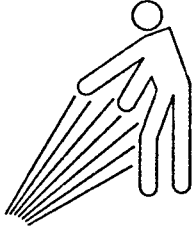

AIR AND OIL UNDER PRESSURE WILL CAUSE SEVERE PERSONAL INJURY OR DEATH. SHUTDOWN COMPRESSOR AND RELIEVE SYSTEM OF ALL PRESSURE BEFORE REMOVING VALVES, CAPS, PLUGS, FITTINGS, BOLTS AND FILTERS.

17EAG0077

<p>HIGH VOLTAGE. ROTATING MACHINERY. AIR AND OIL UNDER PRESSURE. IMPROPER MODIFICATION OF EQUIPMENT WILL CAUSE SEVERE PERSONAL INJURY OR DEATH.</p> <p><small>21EAG0077</small></p>	<p>⚠ DANGER</p> <p>DO NOT MODIFY UNIT WITHOUT WRITTEN PERMISSION FROM MANUFACTURER.</p>
---	--

⚠ WARNING

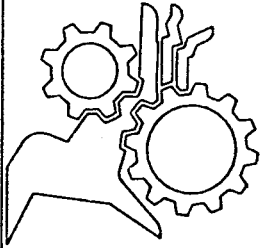

ROTATING MACHINERY CAN CAUSE INJURY OR DEATH. KEEP ALL GUARDS AND SAFETY DEVICES IN PLACE.

21EAG0077

⚠ WARNING

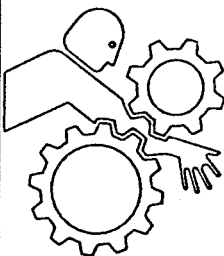

UNIT CAN AUTOMATICALLY RESTART. CAN CAUSE PERSONAL INJURY OR DEATH. KNOW MODE OF OPERATION BEFORE WORKING ON OR NEAR THE MACHINE.

20PLA0077

DECALS

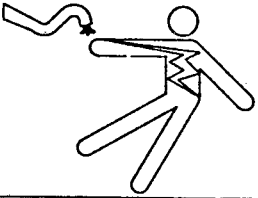
<p>ELECTRICAL SHOCK FROM IMPROPER GROUNDING CAN CAUSE INJURY OR DEATH.</p> <p>GROUND UNIT AND RELATED EQUIPMENT ACCORDING TO NATIONAL ELECTRIC CODE AND LOCAL REGULATIONS.</p> <p><small>2014AG077</small></p>	<p>⚠ WARNING</p>
	

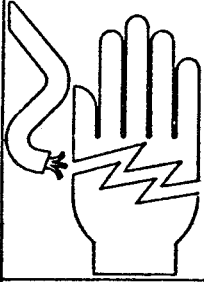
<p>⚠ WARNING</p>

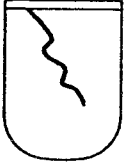
<p>ELECTRICAL SHOCK CAN CAUSE INJURY OR DEATH. DISCONNECT ALL CIRCUITS BEFORE WORKING ON THIS CONTROL. SEE WIRING DIAGRAM.</p> <p><small>2014AG077</small></p>

<p>AIR AND OIL UNDER PRESSURE. CAN CAUSE SEVERE PERSONAL INJURY OR DEATH. INSPECT OIL RESERVOIR FOR CRACKS AT LEAST ANNUALLY.</p> <p><small>2014AG077</small></p>	<p>⚠ WARNING</p>
	

<p>⚠ CAUTION</p>

<p>ELECTRICAL ARCING CAN CAUSE A FIRE WHEN UNIT IS MOUNTED ON A COMBUSTIBLE SURFACE RESULTING IN PERSONAL INJURY OR PROPERTY DAMAGE. UNIT MUST BE MOUNTED ON A FLOOR PLATE EXTENDING ON ALL SIDES. SEE INSTALLATION DRAWING FOR PROPER DIMENSIONS.</p> <p><small>2014AG077</small></p>

<p>⚠ CAUTION</p>

<p>MACHINE DAMAGE OR INJURY CAN OCCUR DUE TO IMPROPER LIFTING. DO NOT LIFT MACHINE WITH THE MOTOR EYEBOLT.</p> <p><small>2014AG077</small></p>

SECTION 2 INSTALLATION

GENERAL - On receipt of the unit, check for any damage that may have been incurred during transit. Report any damage or missing parts as soon as possible.

CAUTION

Do not electric weld on the compressor or base; bearings can be damaged by passage of current.

LIFTING UNIT - Proper lifting and/or transporting methods must be used to prevent damage.

CAUTION

Lift compressor unit by base only. Do not use other places such as enclosure, motor, compressor oil discharge manifold and piping as lifting points.

DANGER

The eyebolts or lugs provided on the motor are for lifting the motor only and should not be used to lift any additional weight. All eyebolts must be securely tightened. When lifting the motor the lifting angle must not exceed 15 degrees. Failure to observe this warning may result in damage to equipment or personal injury.

Lifting slots are provided in the base for towmotor use. Unit may also be moved into location by rolling on bars.

LOCATION - The compressor should be installed where it is protected from rain, snow and freezing temperatures, in a clean, well-lighted, well-ventilated area with ample space all around for maintenance. Select a location that provides a cool, clean, dry source of air. In some cases it may be necessary to install the air filter at some distance from the compressor to obtain proper air supply.

AIR-COOLED UNIT - A combination oil/aftercooler is supplied as standard equipment on all air-cooled units. The air-cooled unit with the standard enclosure requires sufficient flow, Figure 2-2, for the compressor oil/aftercooling system and electric motor cooling. Air is drawn into the unit at the motor side of the enclosure and is exhausted at the oil cooler side. Do not block the air flow to and from the unit. Allow three (3) feet to the nearest obstruction on the starter end and control box

end of the unit. Allow two (2) feet to the nearest obstruction above and on other sides of unit. For continuous efficiency, oil cooler cores must be periodically cleaned with either vacuum or compressed air. If wet cleaning is required, shield motor and spray on a mild soap solution and flush with clean water.

WARNING

For aluminum oil coolers, do not use any cleaning solution that is not compatible with aluminum. Use of improper solution may result in damage to cooler.

FOUNDATION - The Electra-Screw[®] compressor requires no special foundation, but should be mounted on a smooth, solid surface. Whenever possible install the unit near level. Temporary installation may be made at a maximum 10° angle lengthwise or 10° sidewise.

Mounting bolts are not normally required. However, installation conditions such as piping rigidity, angle of tilt, or danger of shifting from outside vibration or moving

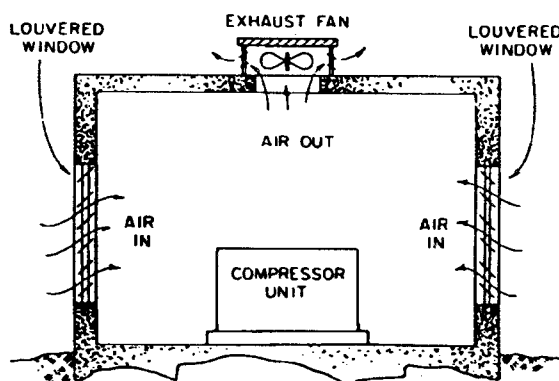

A75119

FIGURE 1-2 - TYPICAL COMPRESSOR ROOM

Minimum Air Flow* For Compressor And Cooling (Cubic Feet/Minute)		
	Air Cooled	
All Models	6000 cfm	

* 80°F inlet air

FIGURE 2-2

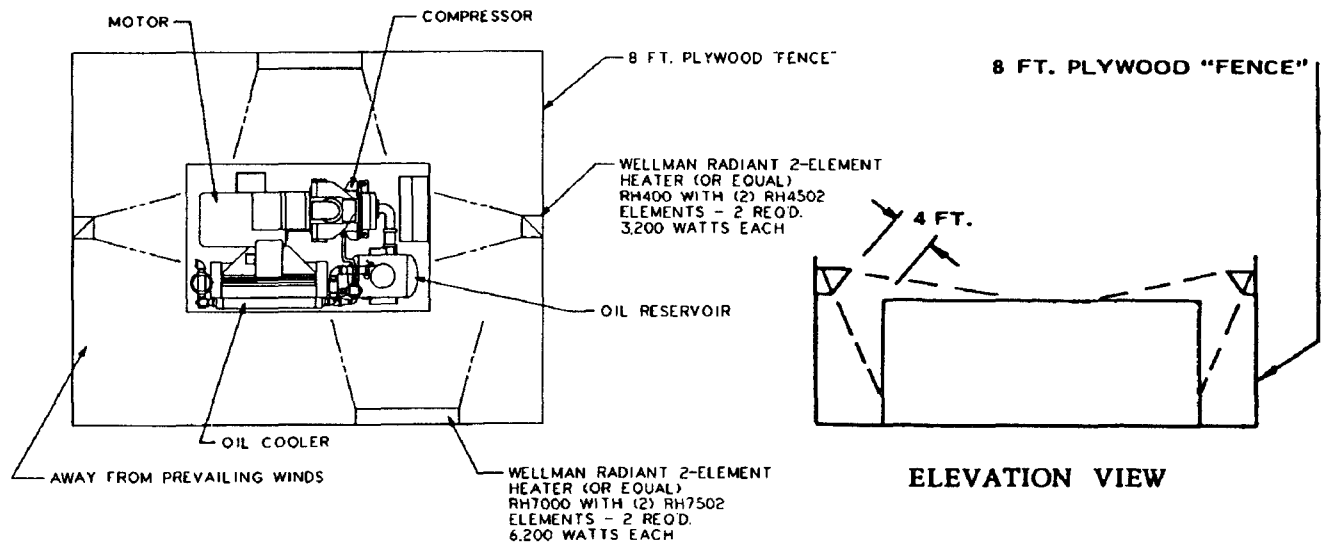

FIGURE 3-2 - COLD WEATHER INSTALLATION

vehicles may require the use of mounting bolts and shims to provide uniform support for the base. Belt alignment and tension should be checked after installation. (For information on belt alignment and tension see Section 7, page 1.)

OIL RESERVOIR DRAIN - The oil drain is piped from the bottom of the reservoir to the side of the frame. This drain is approximately 2 inches above the floor level. If this is not sufficient to conveniently drain the oil some other methods of providing drain are:

1. Elevate the compressor unit on a suitable structure to obtain the desired drain height.

CAUTION

If the compressor unit base is raised above floor level, the space between the floor and the base bottom must be closed with solid material all around to prevent recirculation of hot air from the oil cooler end and over temperature operation.

2. Construct an oil sump or trough below the floor level and pump or bail the drained oil.
3. Pump oil from the reservoir filler opening or drain to a container.

ENCLOSURE - The compressor, electric motor, oil cooler and aftercooler are mounted inside the enclosure.

Service doors are provided for maintenance access. Be sure to allow enough space around the unit for the doors to open completely.

Any of the enclosure doors may be removed by opening the door and lifting it up slightly to disengage the hinges.

DANGER

Do not operate compressor with fan and belt guard removed. Exposed fan and belts may cause injury to personnel.

The motor inspection/air filter service panel is held by two latches and lifts away from the enclosure. The air outlet panel is attached by screws to the enclosure and is not readily removable.

INSTALLATION FOR COLD WEATHER OPERATION

- It is recommended that the unit be installed inside a shelter that will be heated to temperatures above freezing (32°F, 0°C). This will eliminate many of the problems associated with operating units in cold climates, such as freezing in control lines and downstream of the cooler.

Refer to Engineering Data Sheet 13-9-411 for the advantages of using the heat recovered from rotary compressors. This heat recovery could easily pay for an adequate shelter for the unit.

When an outside installation must be made, the precautions required will depend on how severe the environment. The following are general guidelines for outside installations:

Cold Weather (Down To +10°F)

1. Be sure all drains, traps, and control lines, including pressure transducer lines are heated to avoid freezing of condensate. Heat tape with thermostat control is generally satisfactory for this purpose and can be obtained at various local plumbing or hardware outlets at nominal cost.

2. If an air-cooled aftercooler is to be used, provisions to bypass the aftercooler must be made. Since cold air contains very little moisture, successful operation can be achieved without the aftercooler.
3. Provide at least some simple shelter such as a plywood windbreak to protect against drifting snow.
4. Use only Gardner-Denver® AEON™ 9000 lubricant.
5. Monitor unit carefully during start-up and operation to be sure it is functioning normally.
6. Specify NEMA 4 enclosure for electrical devices.

Extreme Cold Weather Operation (Down To -40°F)

In addition to the above, the following should be provided:

1. It will be necessary to provide shutters or to block off part of the cooler in some manner since the cooler is greatly oversized for operation in these low temperatures. Since shutters are not provided as a factory option, blocking off a portion of the cooler with plywood should be satisfactory.
2. Auto operation should not be used in extreme environments.
3. Some means of providing heat during shutdown should be provided. There are various methods to accomplish this, but since openings are not provided for sump heaters, the use of radiant heaters is recommended. The heaters should be sized to provide at least a +10°F environment for coolers, motor and sump. Figure 3-2 shows how these might be located in a typical installation and sizes required.

Remember unsheltered (outside) installations should be avoided where possible. Installation next to a heated building where enough heat can be used to keep the compressor room above freezing will save many complications in the operation and installation of the unit.

Refer to Engineering Data Sheet 13-9-411, available from an authorized Gardner-Denver distributor, for the advantages of using the heat recovered from rotary compressors. This heat recovery could easily pay for an adequate shelter for the unit.

AUXILIARY AIR RECEIVER - An auxiliary air receiver is not required if the piping system is large and provides sufficient storage capacity to prevent rapid cycling. When used, an air receiver should be of adequate size, provided with a relief valve of proper setting, a pressure

gauge and a means of draining condensate.

MOISTURE SEPARATOR/TRAP - Since unit is equipped with a built-in aftercooler, a combination moisture separator and trap is furnished with the unit.

CONTROL PIPING - Control piping is not necessary since the Electra-Screw® unit is factory wired and piped for the control system specified.

INLET LINE - Where an inlet line is used between the air filter and the compressor, it must be thoroughly cleaned on the inside to prevent dirt or scale from entering the compressor. **If welded construction is used, the line must be shot blasted and cleaned to remove welding scale.** In either case, the inlet line must be coated internally by galvanizing or painting with a moisture and oil-proof sealing lacquer. Up to ten (10) feet in length, the inlet line should be the full size of the inlet opening on the compressor. If an extra-long line is necessary, the pipe size should be increased according to Inlet Line Chart below.

Accessibility for inlet air filter servicing must be considered when relocating the filters from the unit to a remote location.

DISCHARGE SERVICE LINE - The discharge service line connection is made at the upper right hand corner of the cooler, viewed from the oil cooler side. A hand operated valve, (air service valve) must be installed between the unit and the customer's air system. When manifolding two or more Electra-Screw® units on the same line, each unit is isolated by the check valve in the unit discharge line. If an Electra-Screw® unit is manifolded to another compressor, be sure the other compressor has a check valve in the line between the machine and the manifold. If an Electra-Screw® and a reciprocating compressor are manifolded together, an air receiver must be located between the two units.

DANGER

Discharge air used for breathing will cause severe injury or death.

Consult filtration specialists for additional filtration and treatment equipment to meet health and safety standards.

BLOWDOWN VALVE PIPING - The blowdown valve is fitted with a muffler for operation indoors. If the installation requires, the muffler may be removed and the blow-

INLET LINE LENGTHS

Length of Inlet Line	Diameter of Pipe Size
0 to 10 Feet.....	Same as Compressor Inlet Opening
10 to 17 Feet.....	One Size Larger Than Inlet Opening
17 to 38 Feet.....	Two Sizes Larger Than Inlet Opening

down valve piped to the outside with a pipe size the same as the blowdown valve outlet connection.

ELECTRICAL WIRING - Standard Units - The Electra-Screw® compressor is factory wired for all starter to motor and control connections for the voltage specified on the order. It is necessary only to connect the unit starter to the correct power supply. The standard unit is supplied with an open drip-proof motor, a NEMA 12 starter and control enclosure. See "Location" paragraph for distance to nearest obstruction on starter and control box sides of the unit.

The overload heaters are to be selected according to starter manufacturer's tables, which are attached to the inside of the control box, based on motor nameplate full load amperage.

WARNING

Electrical shock can cause injury or death. Open main disconnect switch before working on starter/control box.

GROUNDING - Equipment must be grounded in accordance with Section 250 of the National Electrical Code.

WARNING

Failure to properly ground the compressor package could result in controller malfunction.

MOTOR LUBRICATION - Long time satisfactory operation of an electric motor depends in large measure on proper lubrication of the bearings. The following charts show recommended grease qualities and regreasing intervals for ball bearing motors. For additional information refer to the motor manufacturer's instructions. The following procedure should be used in regreasing:

1. Stop the unit.
2. Disconnect the unit from the power supply.
3. Remove the relief plug and free hole of hardened grease.
4. Wipe lubrication fitting clean and add grease with a hand-operated grease gun.
5. Leave the relief plug temporarily off. Reconnect unit and run for about 20 minutes to expell the excess grease.
6. Stop the unit. Replace the relief plug.
7. Restart the unit.

WARNING

Rotating machinery can cause injury or death. Open main disconnect before working on electric motor.

ELECTRIC MOTOR GREASE RECOMMENDATIONS

	Standard Service	High Temperature
Worked Penetration	265-296	220-240
Grease Viscosity, SSU At 100°F	400-550	475-525
Soap Type	Lithium	Lithium
N-H Bomb, Minimum Hours For 20 PSI Drop at 210°F.....	750	1000
Bleeding, Maximum Weight % In 500 Hours 212°F.	10	3
Rust Inhibiting	Yes	Yes

ELECTRIC MOTOR REGREASING INTERVAL

Type of Service	Typical Examples	Rating	Relubrication Interval
Standard	One- or Two-Shift Operation	150 HP & Below	18 Months
Severe	Continuous Operation	150 HP & Below	9 Months
Very Severe	Dirty Locations, High Ambient Temperature	150 HP & Below	4 Months

SECTION 3 STARTING & OPERATING PROCEDURES

PRESTART-UP INSTRUCTIONS - A new unit as received from the factory has been prepared for shipping only. Do not attempt to operate the unit until checked and serviced as follows:

1. **Compressor Oil** - Check oil level in the reservoir. Add oil only if the oil level gauge reads in the red "ADD OIL" range. Do not mix different type oils. Unit is shipped filled with Gardner-Denver® AEON™ 4000 Lubricating Coolant which is suitable for the first 4000 hours under normal operating conditions. (AEON™ 4000 is generally suitable for use up to 6000 hours service life, provided the lubricant is monitored by periodic analysis.

REPLACE OIL FILTER EVERY 1000 HOURS.

Initial fill, or filling after a complete draining of the system, may show the oil level above the FULL mark (the bottom of the top sight gauge). After start-up, the oil level will drop and fluctuate as the machine runs. To check for proper oil level, shut off the machine and allow the foam to settle out. If necessary, add oil to bring the level to the FULL mark. See Figure 3-1, Section 1, page 3.

NOTICE

Regular maintenance and replacement at required intervals of the oil filter, air filter and air-oil separator is necessary to achieve maximum service and extended drain intervals of AEON™ 4000 petroleum base lubricant. Use only genuine Gardner-Denver filters designed and specified for this compressor.

DANGER

Before removing oil filler plug, always stop the unit and release air pressure. Failure to release pressure may result in personal injury or death.

During unloaded operation and after shutdown, the system will partially drain back into the oil reservoir and the oil level may read higher than when operating on load. DO NOT DRAIN OIL TO CORRECT; on the next loaded cycle or start, oil will again fill the system and the gauge will indicate the operating level.

2. **Air Filter** - Inspect the air filter to be sure it is clean and tightly assembled. Refer to Section 6, "Air

Filter," for complete servicing instructions. Be sure the inlet line, if used, is tight and clean.

3. **Piping** - Refer to Section 2, "Installation," and make sure piping meets all recommendations.
4. **Electrical** - Check the wiring diagrams furnished with the unit to be sure it is properly wired. See Section 4, "Controls and Instruments," page 9, for general wiring diagrams and Section 2 for installation instructions.
5. **Grounding** - Unit must be properly grounded according to Section 250 of the National Electrical Code.

WARNING

Failure to properly ground the compressor package could result in controller malfunction.

6. **Rotation** - Check for correct motor rotation using "JOG MODE." Compressor drive shaft rotation must be clockwise standing facing the compressor sheave. See Section 4, page 5, step 8.

WARNING

Operation with incorrect motor rotation can damage equipment and cause oil eruption from the compressor inlet. When checking motor rotation, induce minimum rotation (less than one revolution if possible). Never allow motor to reach full speed.

7. **System Pressure** - Set the controls to the desired load pressure. DO NOT EXCEED MAXIMUM OPERATING PRESSURE ON COMPRESSOR NAMEPLATE. See Section 4, pages 4 through 7, "Controls and Instruments," for procedure.

WARNING

Operation at excessive discharge air pressure can cause personal injury or damage to equipment. Do not adjust the full discharge air pressure above the maximum stamped on the unit nameplate.

8. **Operating Mode** - Refer to Section 4 for detailed

information on the control system.

9. **Enclosure** - Check for damaged panels or doors. Check all screws and latches for tightness. Be sure doors are closed and latched.

STARTING THE UNIT - Observe the following starting procedures.

Unit Cold:

1. Close the air service valve (customer furnished) between the main air system and the check valve on the package.
2. If the unit is water-cooled, open any manual water inlet valves wide open.
3. Start the unit by pushing either the "CONSTANT RUN" or one of the "AUTO" buttons.
4. Run for approximately five minutes or until the temperature stabilizes and then open the air service valve.

The unit is equipped with a minimum (65 psig) pressure/check valve, no special procedure to maintain the unit reservoir pressure is required.

Unit Hot (No warm-up period is required):

1. Close the air service valve (customer furnished) between the main air system and the check valve

on the package.

2. If the unit is water-cooled, open any manual water inlet valves wide open.
3. Start the unit by pushing either the "CONSTANT RUN" or one of the "AUTO" buttons.
4. Run for approximately one minute and then open the air service valve.

The unit is equipped with a minimum (65 psig) pressure/check valve, no special procedure to maintain the unit reservoir pressure is required.

DAILY CHECK - Refer to Section 8, "Maintenance Schedule."

STOPPING THE UNIT:

1. Close the air service valve (customer furnished) between the main air system and the check valve on the package.
2. Allow the unit to build up to full unloaded pressure and run unloaded for 1 to 2 minutes.
3. Wait a short period for the reservoir to blow down.
4. Press "STOP-RESET" button.

Stopping the unit at a pressure below full unloaded may cause oil carry-over and can damage the air/oil separator element. The oil reservoir will automatically blow down as the motor stops. Open the air service valve.

SECTION 4 CONTROLS & INSTRUMENTATION

GENERAL - The Gardner-Denver® "EBE" Electra-Screw® compressor is supplied with a factory mounted starter and complete controls as standard equipment. The standard control system consists of constant run load/unload operation, or auto start/timed stop operation. Lead/Lag operation of two EBE compressors is also possible without additional equipment. Inlet valve modulation is standard.

PROTECTIVE DEVICES - All compressors incorporate the following protective devices:

Motor Protection Devices - Overload heaters are furnished for the starter in the voltage range specified. There are three (3) overloads in the starter of proper size for the starter and its enclosure. An overload trip is indicated by the "MOTOR OVERLOAD" LED located on the control keypad.

Optional Motor Protective Devices - Wye-Delta Starter - Overload heaters are furnished for the starter in the voltage range specified. There are three (3) overloads in the starter of proper size for the starter and its enclosure. Note that motor nameplate current must be multiplied by .577 for wye-delta starters. Proper starter coil and contact action is also monitored to ensure proper operation.

Separator Differential Pressure - The Separator differential pressure is continually monitored by the microprocessor controller. At a differential of approximately 8 PSI, the "CHANGE SEPARATOR" LED located on the control

keypad flashes indicating required maintenance. If the warning is ignored, and the separator differential continues to increase, the microprocessor controller will stop the unit and the LED will remain on steady. See "Control System Operation" in this section for further information on operation of the microprocessor controller.

High Discharge Temperature - The compressor is protected from high discharge temperature by two independent thermistor probes. One probe is located in the compressor discharge housing to sense compressor discharge air-oil mixture temperature. The second probe is located at the separator discharge and senses the temperature of the air at the oil separator.

The microprocessor controller will shut the compressor down if the temperature sensed at either location exceeds 225° F. See "High Air Temperature LED," Section 4, page 4.

CAUTION

Machine damage will occur if repeatedly restarted after high temperature stops operation. Find and correct the malfunction before resuming operation.

Relief Valve - A pressure relief valve(s) is (are) installed

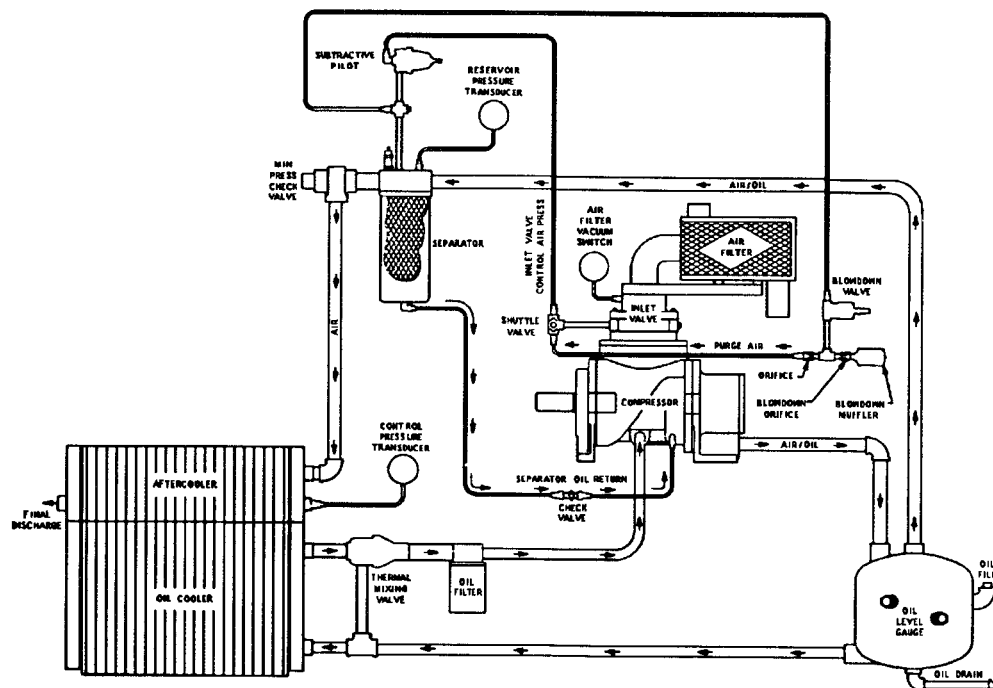

FIGURE 1-4 - CONTROL SCHEMATIC

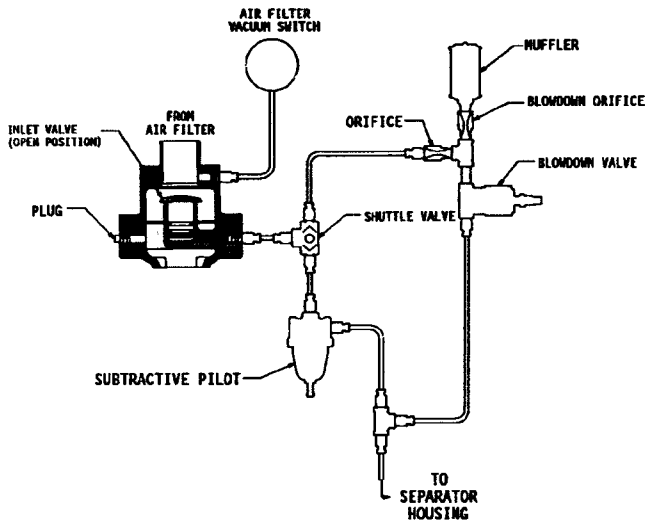

FIGURE 2-4 - INLET VALVE

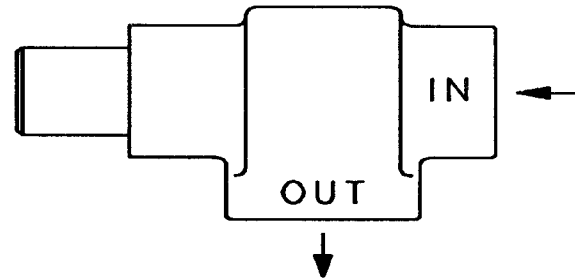

FIGURE 3-4 - MINIMUM PRESSURE/CHECK VALVE

in the final discharge line and set at the factory to approximately 120% of the unit's full load operating pressure for protection against overpressure. Periodic checks should be made to insure its proper operation.

WARNING

When relief valve opens, a stream of high velocity air is released, resulting in a high noise level and possible discharge of accumulated dirt or other debris. Always wear eye and ear protection and stand clear of the discharge port when testing the relief valve to prevent injury.

CAUTION

Never paint, lubricate or alter a relief valve. Do not plug vent or restrict discharge.

WARNING

Operation of unit with improper relief valve setting can result in severe personal injury or machine damage.

Insure properly set valves are installed and maintained.

Blowdown Valve (Figure 1-4) - The blowdown valve releases pressure from the oil reservoir. See description under "Air Control Components," below, for construction and operation information.

INSTRUMENTS - All units incorporate the following instruments and indicators:

Oil Sight Gauges (Figure 3-1, Section 1, page 3) - These gauges indicate the level of the oil in the reservoir. See Section 5, page 3 "Lubrication, Oil Cooler, Oil Filter and Separator", for information on how to correctly read these gauges. All other instruments are a part of the microprocessor controller. See "Air Control Components," below.

AIR CONTROL COMPONENTS - All units incorporate the following air control components. See Figure 1-4 for schematic tubing diagram.

Inlet Valve (Figure 2-4) - The inlet valve is a pilot-actuated valve that restricts the inlet to control capacity and closes to unload the compressor. At shutdown the inlet valve closes to function as a check valve and prevent backflow of air.

As control pressure is increased the valve will begin to close, restricting the inlet and reducing compressor capacity. Approximately 18 psig of control pressure is required to close the inlet valve completely. When closed, the inlet valve prevents the flow of air in either direction. With optional modulating control feature: when the control pressure is less than 18 psig, the inlet valve will modulate to match compressor capacity to system demand.

Blowdown Valve (Figure 2-1) - The blowdown valve is a two-way solenoid valve that is piped into the oil separator outlet, but ahead of the check valve. When the solenoid is de-energized, the blowdown valve opens, and the oil system is blown down. When the solenoid is energized, the blowdown valve closes, and allows the oil system to pressurize.

Minimum Pressure/Check Valve (Figure 3-4) - An internal spring-loaded minimum pressure valve is used in the final discharge line to provide a positive pressure

on the oil system even when the air service valve is fully open. The valve senses upstream pressure. If demand for air exceeds the compressor capacity, the valve throttles the flow to maintain a minimum pressure on the upstream (oil reservoir) side of the valve. When pressure rises above the minimum pressure (standard setting 60 to 65 PSIG) the valve reaches the full open position.

A check valve incorporated in the minimum pressure valve prevents backflow of air from the shop air line when the unit stops, unloads or is shut down.

The valve does not require maintenance or adjustment. If the valve fails to function, it must be replaced because it is not field adjustable or field repairable.

DANGER

Air and oil under pressure will cause severe personal injury or death. Shut down compressor and relieve system of all pressure before removing valves, caps, plugs, fittings, bolts, and filters.

STARTER/CONTROL BOX (Figure 3-1) - The following control components are located on the combination starter/control box.

Hourmeter - A continuous reading (nonreset) type hourmeter displays the accumulated operating time of the unit and provides a convenient means for scheduling changes of oil and servicing of filters, separators and other devices.

Auto-Sentry S Controller With Keypad - Monitors and controls compressor operation. **Emergency Stop Pushbutton** - Removes power from the microprocessor controller outputs to provide a positive means of stopping the unit in an emergency situation.

Control System Operation - See Figure 1-4, Section 4, page 1.

"STOP/RESET" Button With LED - This button is used to stop the compressor under ordinary conditions. It is also used to extinguish any fault LED's that are illuminated. In addition, it is used in the procedure to adjust the operating pressure. See "Adjusting the Operating Pressure." The LED is illuminated whenever the unit is stopped for any reason EXCEPT a normal shutdown in one of the "AUTO" modes. A flashing LED indicates that a reset is required.

CAUTION

Machine damage will occur if repeatedly restarted after any one of the shutdown modes stops operation of the unit. Find and correct the malfunction before resuming operation.

"CONSTANT RUN" Button With LED - This button is used to operate the unit in the constant run mode. In this mode, the compressor runs continuously, loading and unloading in response to air demand. It will continue to run until stopped, either manually or by a protective shutdown. The LED is illuminated at all times while running in this mode.

"AUTO LEAD" Button With LED - This button is used to operate the unit in the "Auto-Start-Timed-Stop" mode, either by itself, or as the lead compressor in a Lead/Lag arrangement. Loading and unloading occurs as in the "CONSTANT RUN" mode, however, if the compressor runs unloaded for a period of 10 minutes, the unit is stopped. At this point, the compressor remains in the "AUTO LEAD" mode and will restart when the system pressure reaches the 'load' setpoint programmed into the controller. The LED will remain illuminated throughout the cycle.

WARNING

**Unit can automatically restart causing personal injury.
Know operating mode before working on or near machine.**

"AUTO LAG" Button With LED - This button is used to select the 'lag' unit in a lead-lag arrangement. Operation is identical to "AUTO LEAD" except that the start-load and unload setpoints are automatically 5 PSI lower than programmed.

NOTICE

Any mode may be selected at any time without stopping the compressor.

"HIGH AIR TEMPERATURE" LED - This LED is used to indicate an over temperature condition at either the compressor or oil separator discharge. At the time of a high temperature shutdown, the LED is illuminated and the temperature digital readout is locked on to the offending temperature. Illumination of the decimal point in the lower right hand corner of the digital readout indicates that the temperature displayed is at the oil separator. A non-illuminated decimal point indicates compressor discharge. Pressing "STOP/RESET" will extinguish the LED (if the temperature has lowered below 225°F) and revert the digital readout to displaying actual discharge temperature.

"MOTOR OVERLOAD" LED - This LED indicates that the motor overload relay has tripped. The overload relay itself must be reset before pressing "STOP/RESET" will extinguish the LED.

"CHANGE SEPARATOR" LED - This LED flashes when the differential pressure across the oil separator reaches approximately 8 PSI. At this point, schedule the separator element for service at the earliest opportunity. (See Section 5, pages 4 & 5, for separator maintenance.)

Should the condition be ignored and allowed to further deteriorate, the compressor will be shutdown and the LED illuminated steadily when the differential pressure reaches 15 PSI.

CAUTION

Machine damage will occur if repeatedly restarted after any one of the shutdown modes stops operation of the unit. Find and correct the malfunction before resuming operation.

"CHANGE AIR FILTER" LED - This LED is used to signal when the air filter requires servicing or changing. It is a reminder only and will not stop or impede the operation of the unit. Operating the compressor with the LED illuminated risks collapse of the filter and ingestion into the compressor.

CAUTION

Machine damage can occur with extended operation after "Change Air Filter" LED illuminates. Service air filter as soon as possible.

Pressure And Temperature Digital Readouts - These readouts normally indicate pressure at the minimum pressure check valve and temperature at the air end discharge. See "High Air Temperature LED," page 3, this section, for a description of readout action during a high temperature condition. Alternately, these readouts can be selected to display oil reservoir pressure and separator air temperature. To obtain such display while the compressor is running, simply press the operating mode

button that corresponds to the current operating mode of the unit. (For Example: If the unit is operating in "AUTO LEAD" mode, press the "AUTO LEAD" button.) This will cause the readout to display the alternate parameters. This alternate display mode is indicated by illuminated decimal points in the lower right hand corner of each display. After releasing the button, the display will revert to its normal mode in 5 seconds.

The digital readouts are also used to display error messages. These error messages correspond to various indications concerning condition of the pressure and temperature sensors and EMERGENCY STOP condition.

DEFINITIONS OF ERROR MESSAGES - Refer to chart in Figure 4-4 below for definitions.

An error message will stop the compressor, if running, and prevent it from restarting. The failed sensor must be replaced to clear the error.

Any condition requiring the control panel to be reset will be indicated by a flashing "STOP/RESET" LED. If all readouts and LED's are flashing, a power interruption has occurred, requiring the control panel to be reset.

Programming The Load-Unload Pressure Setpoints - Programming of the Load and Unload Pressure setpoints can only be accomplished with the unit not running.

Step 1: Stop the compressor and remove all power from the unit by opening main disconnect.

WARNING

Electrical shock can cause injury or death. Open main disconnect and any other circuits before working inside control box.

Step 2: Turn the "Setup" switch located on the controller circuit board (inner side of control box door) to the "+" position. Close control box door and restore power.

Pressure Readout		Temperature Readout	
Error #	Meaning	Error #	Meaning
E01	Failure of final discharge pressure sensor	E01	Failure of compressor temperature sensor
E02	Failure of oil sump pressure sensor	E02	Failure of separator temperature sensor
E03	Failure of both pressure sensors	E03	Failure of both temperature sensors
E04	EMERGENCY STOP		

FIGURE 4-4 - DEFINITIONS OF ERROR MESSAGES

Figure 8-4.

Step 7: When the desired load setpoint is displayed in the pressure readout, press the "STOP/RESET"

current sump temperature in the right window.

Step 12: Move the circuit board slide switch back to the "set" position (right). You may now proceed with normal start up procedure.

NOTE

- A. To readjust, the slide switch must be in the "+" position.
- B. If procedure is repeated, the transducer zero operation may be bypassed by not pressing "Stop-Reset" while the dashes (----) are displayed.
- C. Transducer must be zeroed only while at zero "0" pressure, or invalid shutdowns may occur.

LEAD-LAG OPERATION OF TWO COMPRESSORS -

The Auto-Sentry S controller provides the capability of true lead-lag operation without the need to purchase any additional equipment and without complicated interconnecting wiring.

Follow these steps to operate two compressors in a lead-lag arrangement:

- Step 1: Program load and unload pressure setpoint on both units to the same value. For example: Compressor "A" load at 92 PSI; unload at 100 PSI. Compressor "B" load at 92 PSI; unload at 100 PSI. See page 6, this section, for complete information on programming the setpoints.

WARNING

Operation at excessive discharge air pressure can cause personal injury or damage to equipment. Do not set unload pressure above the maximum stamped on the unit nameplate.

- Step 2: Operate one compressor in the "Auto Lead" mode. This compressor will now be the "Lead" or "Base Load" compressor.
- Step 3: Operate the second compressor in the "Auto Lag" mode. This compressor will now be the "lag" or "trim" compressor. It will automatically be brought on line, if required, by a large air demand. After the demand is satisfied, the lag unit will unload, time out and stop, ready to start again when needed.
- Step 4: Periodically reverse the roles of the units by changing each unit's mode of operation from "Auto Lead" to "Auto Lag" and vice versa. By using the hourmeters on the control panel to schedule the mode changes, the operating hours can be kept as close as possible, equalizing machine wear and minimizing maintenance costs.

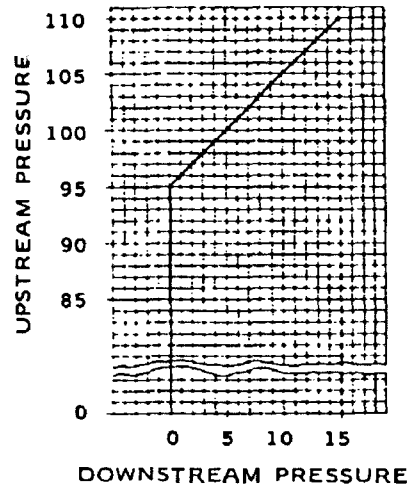

FIGURE 5-4

WARNING

Unit can automatically restart causing personal injury.

Know operating mode before working on or near machine.

Subtractive Pilot (Modulating Feature) - The subtractive pilot is an adjustable, spring-loaded diaphragm valve that controls pressure in relation to the upstream (discharge) pressure.

The downstream pressure is maintained equal to the upstream pressure minus a constant which is adjustable. In the example shown in Figure 5-4, above, the downstream pressure equals the upstream pressure minus 95 psi. When the upstream pressure rises to 100 psig, the downstream pressure rises to 5 psig. This 1 to 1 psi rise is constant above the set point.

Below the set point, the valve seat is closed and the downstream pressure is vented. In the example of Figure 5-4, page 7, downstream pressure is vented below 95 psig.

Figure 6-4, page 7, this section, shows a schematic cross section of the subtractive pilot with the valve seat closed and downstream line vented. Figure 7-4, page 6, this section, shows the pilot with valve seat open, holding a downstream pressure which is adjustable with the screw. In this position it is normal for the valve to continually bleed air through the small vent hole in the bowl.

Moisture, oil and dirt in the control system lines and components can cause the set point of the subtractive pilot to shift or be erratic. The subtractive pilot can be disassembled and the diaphragm and ports cleaned when necessary.

Operating Air Pressure Adjustment - The Auto-Sentry S controller load and unload pressure setpoints

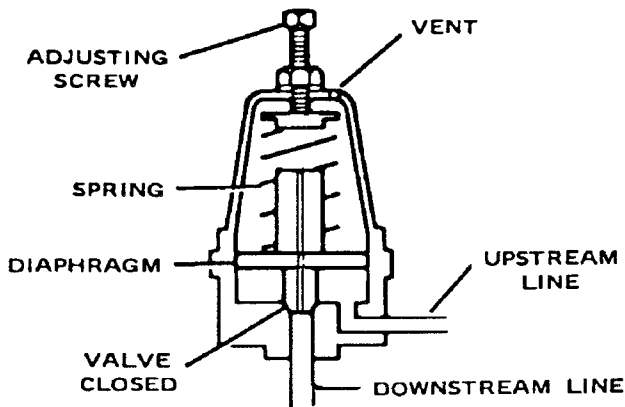

FIGURE 6-4 - SUBTRACTIVE PILOT (CLOSED)

should already be programmed. See page 6 and Figure 8-4 below.

WARNING

Operation at excessive discharge air pressure can cause personal injury or damage to equipment. Do not set unload pressure above the maximum stamped on the unit nameplate.

To adjust the subtractive pilot:

1. With the unit off, loosen the locknut and back out the adjusting screw several turns so the subtractive pilot will fully unload the compressor before the unload pressure setpoint of the microprocessor controller is reached.

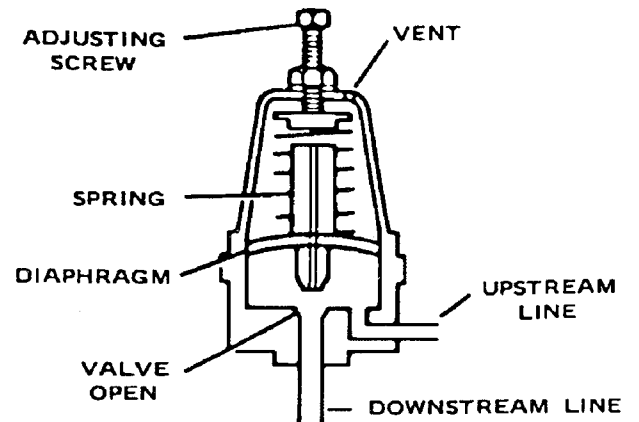

FIGURE 7-4 - SUBTRACTIVE PILOT (OPENED)

2. Close the air service valve and start the unit in the "CONSTANT RUN" mode. Allow unit to reach the pressure at which the subtractive pilot fully unloads the compressor.
3. Turn-in the adjusting screw until the unload pressure setpoint is reached and the microprocessor controller allows the unit to blow down.
4. Turn-in the adjusting screw an additional one-eighth (1/8) turn and tighten the locknut. As a result, the subtractive pilot will not fully unload the compressor before the microprocessor controller's unload pressure setpoint is reached.
5. Using the air service valve, cycle the unit between load and unload several times to be certain that the unit will reach the microprocessor controller's unload pressure setpoint and blow down.

NAMEPLATE FULL LOAD OPERATING PRESSURE	MODULATING CONTROL SYSTEM	
	LOAD	UNLOAD
100	100	108
125	125	133
150	150	158
175	---	---

NOTE

**Load setpoint cannot be set within 8 psi of the unload setpoint.
Minimum operating pressure is 60 - 65 PSIG.**

FIGURE 8-4 - MAXIMUM SETPOINTS FOR AUTO-SENTRY S CONTROLLER, PSIG

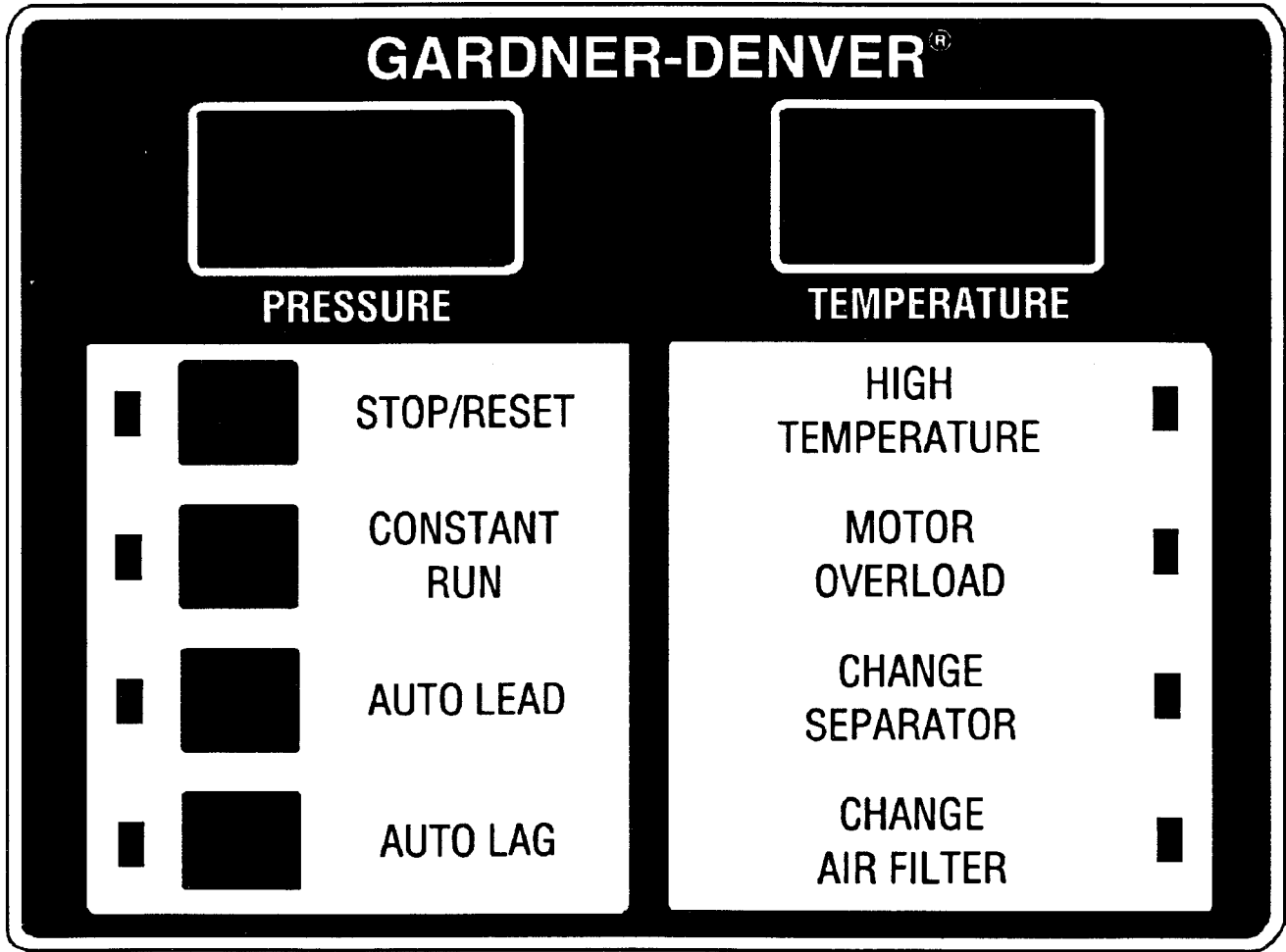
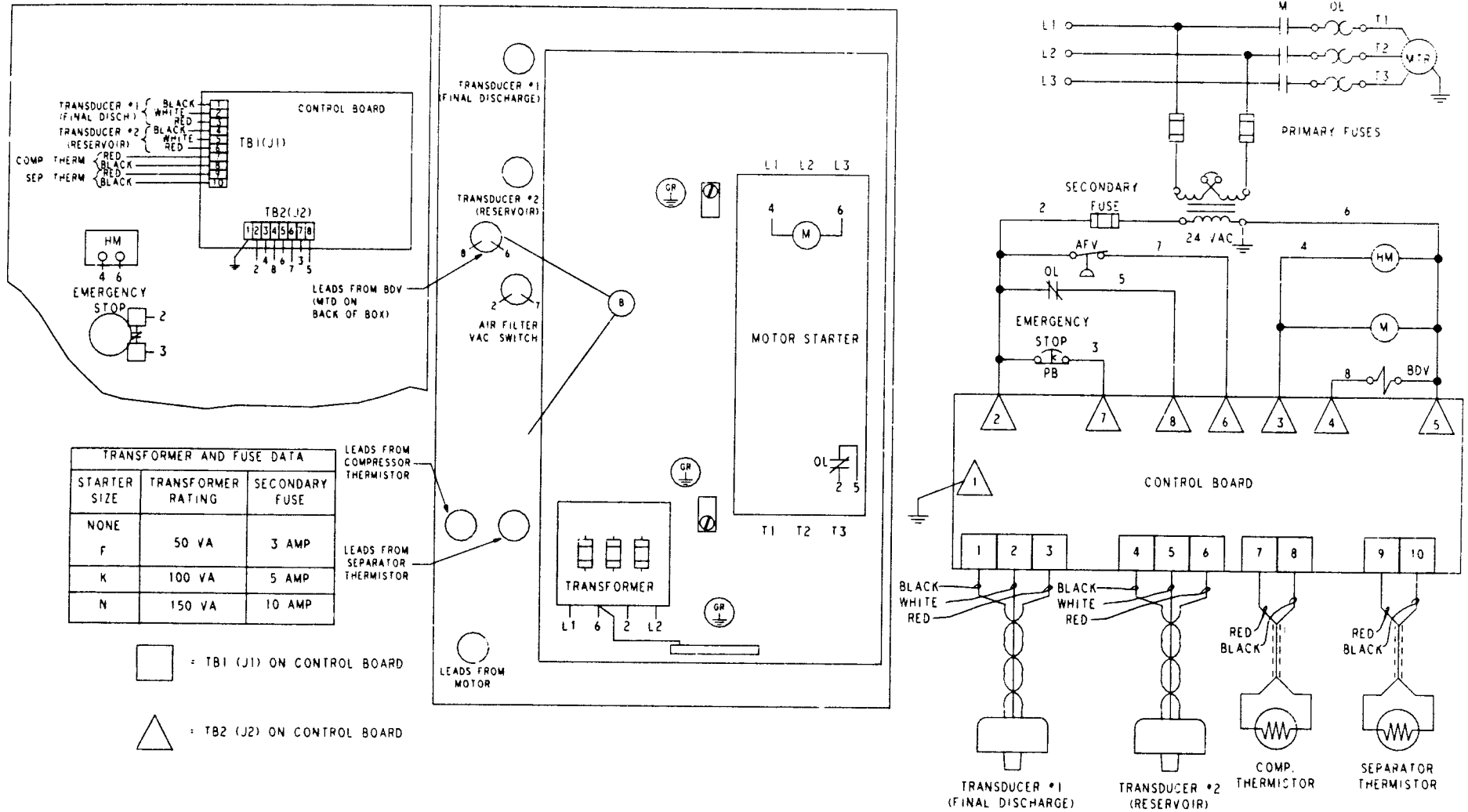

FIGURE 9-4 - AUTO SENTRY "S" SOLID STATE CONTROL TOUCH PAD



218EBE546

FIGURE 10-4 - WIRING DIAGRAM - DUAL CONTROL

**SECTION 5
LUBRICATION
OIL COOLER, OIL FILTER & SEPARATOR**

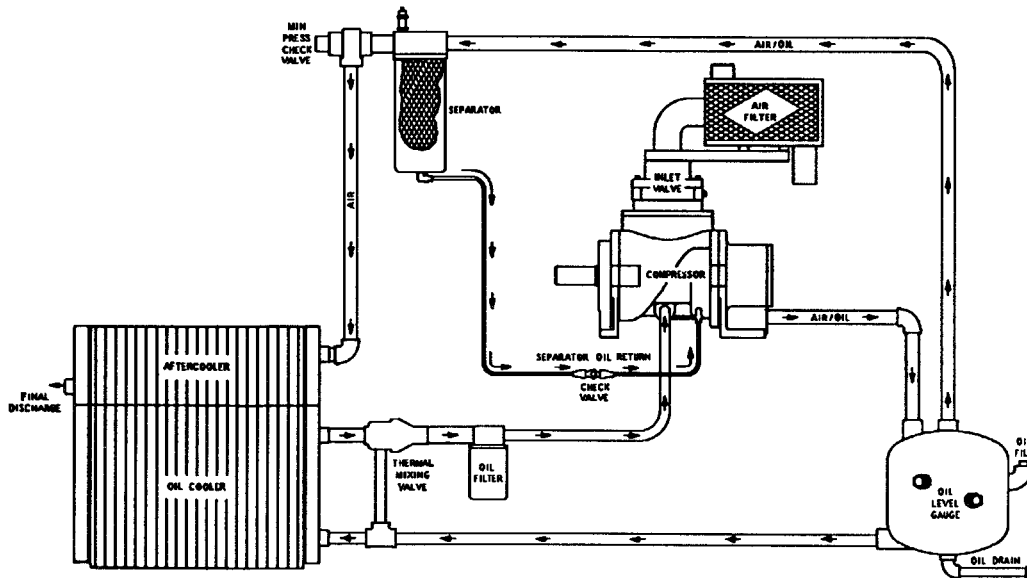

FIGURE 1-5 - FLOW DIAGRAM - AIR-OIL SYSTEM

COMPRESSOR OIL SYSTEM (Figures 1-5) cools the compressor, lubricates moving parts and seals internal clearances in the compression chamber.

The oil inlet line is connected at the bottom of the oil reservoir. Air pressure in the oil reservoir forces oil through the oil cooler, thermostatic mixing valve, oil filter and into the compressor main oil gallery.

The oil passes through internal passages for lubrication, cooling and sealing. The air-oil mixture is then discharged to the oil reservoir where a large part of the entrained oil drops out of the air stream; the air then passes through the final oil separator where most of the remaining oil is removed. The separated oil is returned to the compressor and the air passes to the final discharge line.

RECOMMENDED LUBRICANT - Gardner-Denver compressors are factory filled with AEON™ lubricants. These lubricants are formulated to the highest quality standards and are factory authorized, tested and approved for use in rotary screw compressors. AEON™ lubricants are available through your authorized Gardner-Denver compressor distributor.

OIL SPECIFICATIONS - The recommended compressor lubricant is Gardner-Denver AEON™ 4000 Lubricating Coolant which can be used for year-round operation except as noted in the "High Temperature Operation" paragraph below, or low temperature, see "Installation for Cold Weather," Section 2, page 2. AEON™ 4000 Lubricating Coolant is a superior petroleum base lubricant formulated and containing additives for use in

Gardner-Denver compressors.

CAUTION

Use of improper lubricants will cause damage to equipment. Do not mix different types of lubricants or use inferior lubricants.

HIGH TEMPERATURE OPERATION - If the discharge temperature is sustained between 200-210°F for a period of more than four (4) hours due to continuing high ambient air temperature, use Gardner-Denver® AEON 9000 Lubricating Coolant which is a superior synthetic lubricant. Short periods of up to four (4) hours of sustained discharge temperatures up to 210°F do not require a change from the recommended year-round lubricant AEON™ 4000.

LUBRICANT CHANGE PROCEDURE - Upgrading to a longer life lubricant is essentially a very worthwhile practice. Following are the primary steps to be completed when upgrading or changing the type of lubricant.

1. Thoroughly drain system:
 - Drain oil from air end and cooler while hot.
 - Break low point connections and drain oil from pipe runs.
 - Dump Oil from filter and reinstall used filter.
2. Fill system with a 50 percent charge of the new lubricant:

- Start machine and stay there to observe.
 - Allow machine to run about five minutes at temperature, or until temperature stabilizes, then shut down.
3. Thoroughly drain machine.
 4. Change to new filter and separator.
 5. Fill system with full charge of the new lubricant.
 6. Machine should then be run normally, however, total run time after the initial changeout should be 50 percent of normal anticipated service life of the new lubricant.
- Drain all lubricant from system, change filter and separator, and replace with full charge of the new lubricant.

WARNING

All materials used in Gardner-Denver compressor units are compatible with AEON™ 9000 Lubricating Coolant. Use caution when selecting downstream components such as air line lubricating bowls, gaskets and valve trim.

AEON™ 9000 Synthetic Lubricant is not compatible with low nitrile Buna N or acrylic paints. AEON™ 9000 is compatible with most air system downstream components.

CAUTION

Improper equipment maintenance with use of synthetic lubricants will damage equipment. Oil filter and oil separator change intervals remain the same as for AEON™ 4000 – See maintenance schedule, Section 8.

DANGER

Oil under pressure will cause severe personal injury or death. Shut down compressor and relieve system of all pressure before removing valves, caps, plugs, fittings, bolts and filters.

WARNING

High temperature operation can cause damage to equipment or personal injury. Do not repeatedly restart after high temperature stops operation. Find and correct the malfunction before resuming operation.

Material Safety Data Sheets (MSDS) are available for all AEON lubricants from your authorized Gardner-Denver distributor or by calling 217-222-5400.

COLD AMBIENT OPERATION - See "Installation for Cold Weather Operation," Section 2.

ADDITION OF OIL BETWEEN CHANGES must be made when the oil level is below the center of the lower sight gauge as read while the unit is running fully loaded & not cycling on and off. (Alternate method is when unit is completely off and blown down.)

1. Be sure the unit is completely off and that no air pressure is in the oil reservoir.
2. Disconnect the power supply to the starter.
3. Wipe away all dirt around the oil filler plug.
4. Remove the oil filler plug and add oil as required to return the oil level to the bottom of the upper sight gauge.

DO NOT OVERFILL (you should not see oil in the upper sight gauge when running fully loaded). The quantity required to raise the oil level from "ADD" to "FULL" is shown in Figure 2-5, below. Repeated addition of oil between oil changes may indicate excessive oil carry-over and should be investigated.

Reservoir Capacity to "FULL" Level.....	2.5 U.S. Gallons
System Capacity: Reservoir Plus Oil Cooler and Piping.....	3.5 U.S. Gallons
"ADD" Range to "FULL" Level	3.0 U.S. Quarts

FIGURE 2-5 - APPROXIMATE OIL SYSTEM CAPACITIES

DANGER

Air/oil under pressure will cause severe personal injury or death. Shut down compressor and relieve system of all pressure before removing valves, caps, plugs, fittings, bolts, and filters.

DANGER

Air/oil under pressure will cause severe personal injury or death. Shut down compressor and relieve system of all pressure before removing valves, caps, plugs, fittings, bolts, and filters.

CAUTION

Excessive oil carryover can damage equipment. Never fill oil reservoir above "FULL" marker.

OIL LEVEL SIGHT GAUGES (Figure 3-1, Section 1, page 3) indicate the amount of oil in the oil reservoir. Read oil level when unit is running fully loaded and not cycling on and off. In operation the oil level will fluctuate as the compressor loads and unloads.

MOISTURE IN THE OIL SYSTEM - In normal humidity and with normal operating temperatures and pressures, the thermal mixing valve controls the oil temperature and prevents moisture contamination of the oil. Unusual cooling of the oil reservoir, short loaded cycle in high humidity or malfunctions of the thermal valve may result in moisture in the oil system which is detrimental to compressor lubrication and could cause oil carryover. If moisture is observed in the oil reservoir, drain the moisture and correct the condition causing the accumulation. See "Compressor Oil System Check" and "Thermal Control (Thermostatic Mixing) Valve" in this section.

OIL CHANGE INTERVAL - Recommended oil change intervals are based on oil temperature.

AEON 4000

<u>Discharge Temperature</u>	<u>Oil Change Interval</u>
Up to 180°F	6000 hrs.
180 to 190°F	4500 hrs.
190 to 200°F	3000 hrs.
200 +	1500 hrs.

When operating conditions are severe (very dusty, high humidity) it will be necessary to change the oil more frequently. Operating conditions and the appearance of the drained oil must be surveyed and the oil change intervals planned accordingly by the user. A lubricant analysis program can provide maximum service life and assist in planning the change interval.

DRAINING AND CLEANING OIL SYSTEM -

Always drain the complete system. Draining when the oil is hot will help to prevent varnish deposits and carry away impurities. To drain the system, use one of the following methods:

If the unit is not elevated high enough to use the oil reservoir drain line to drain oil, a small hand, electric or air operated pump should be used to drain reservoir through the oil filler opening or from the drain valve.

If the unit is elevated so that the oil reservoir drain can be used, empty the oil reservoir through the drain valve to a suitable container or sump.

If the drained oil and/or the oil filter element are contaminated with dirt, flush the entire system: reservoir, oil cooler, mixing valve and lines. Inspect the oil separator elements for dirt accumulation; replace if necessary. If a varnish deposit exists, contact the factory for recommendations for removal of the deposit and prevention of varnish.

FILLING OIL RESERVOIR -

DANGER

Air/oil under pressure will cause severe personal injury or death. Shut down compressor and relieve system of all pressure before removing valves, caps, plugs, fittings, bolts, and filters.

1. Be sure the unit is completely off and that no air pressure is in the oil reservoir.
2. Disconnect the power supply to the starter.
3. Wipe away all dirt around the oil filler plug.
4. Remove the oil filler plug and add oil as required to return the oil level to the bottom of the upper sight gauge.
5. Operate unit for about a minute allowing oil to fill all areas of the system.
6. Shut down unit, allowing the oil to settle, and be certain all pressure is relieved.
7. Add oil, if necessary, to bring level to "FULL."

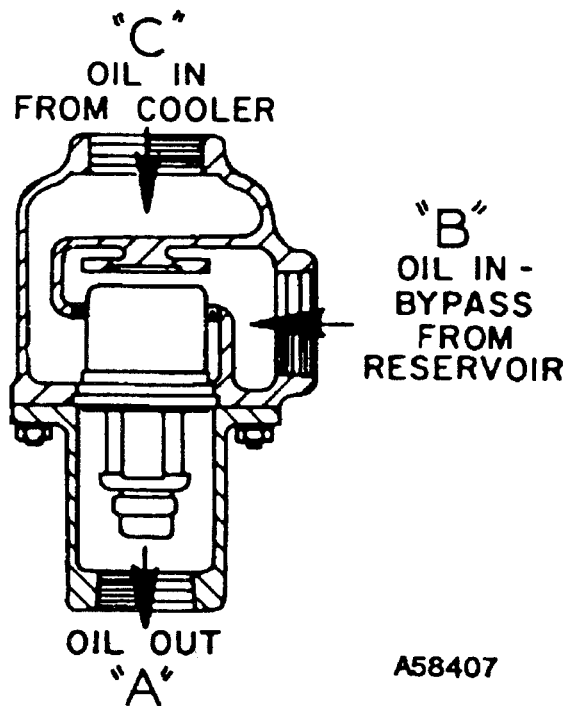

FIGURE 3-5 - THERMOSTATIC MIXING VALVE

On unloaded operation and after shutdown some oil will drain back into the oil reservoir and the oil level will read over "FULL". DO NOT DRAIN OIL TO CORRECT. On the next start, oil will again fill the system and the gauge will indicate operating at the proper level. DO NOT OVERFILL (you should not see oil in the upper sight gauge when running fully loaded) as oil carryover will result. The quantity of oil required to raise the oil level from "ADD" to "FULL" is shown in Figure 2-5, page 2, in this section. Repeated addition of oil between oil changes may indicate excessive oil carryover and should be investigated.

Use only CLEAN containers and funnels so no dirt enters the reservoir. Provide for clean storage of oils. Changing the oil will be of little benefit if done in a slipshod manner.

CAUTION

Excessive oil carryover can damage equipment. Never fill oil reservoir above "FULL" marker.

COMPRESSOR OIL FILTER (Figure 2-1, Section 1, page 2) - This replaceable element filter is a vital part in maintaining a trouble-free compressor, since it removes dirt and abrasives from the circulated oil. The filter is equipped with a relief valve that opens in the event the element becomes dirty enough to block the flow of oil.

CAUTION

Improper oil filter maintenance will cause damage to equipment. Replace filter element every 1000 hours of operation. more frequent replacement could be required depending on operation conditions. Filter element left in service too long may damage equipment.

Use only the replacement element shown on the filter tag or refer to the parts list for the part number. Use the following procedure to replace the filter element. Do not disturb the piping.

DANGER

Air/oil under pressure will cause severe personal injury or death. Shut down compressor and relieve system of all pressure before removing valves, caps, plugs, fittings, bolts, and filters.

1. Stop unit and be sure no air pressure is in the oil reservoir.
2. Remove the spin-on element.
3. Clean the gasket face of the filter body.
4. Coat the new element gasket with clean lubricant used in the unit.
5. Screw new element on filter body and tighten by hand. DO NOT OVERTIGHTEN ELEMENT.
6. Run the unit and check for leaks.

COMPRESSOR OIL COOLER - (Figure 5-1, page 1, this section) - The cooler fan is mounted on the compressor motor shaft; air is exhausted through the oil cooler and away from the unit. Do not obstruct air flow to and from the oil cooler. Allow a minimum of two (2) feet clearance around the cooler. Keep both faces of the cooler core clean for efficient cooling of the compressor oil.

THERMAL CONTROL (THERMOSTATIC MIXING) VALVE (Figure 3-5) is installed in system as shown in Figure 1-5, page 1, this section. This valve is used to control temperature of the oil both air-cooled radiator and water-cooled heat exchanger type oil cooler systems. On start-up with unit cold, element is open to bypass, allowing oil to pass directly from the reservoir to compressor during warm-up. As oil warms, element gradually closes to the bypass allowing more of the oil from the cooler to mix with oil from the bypass.

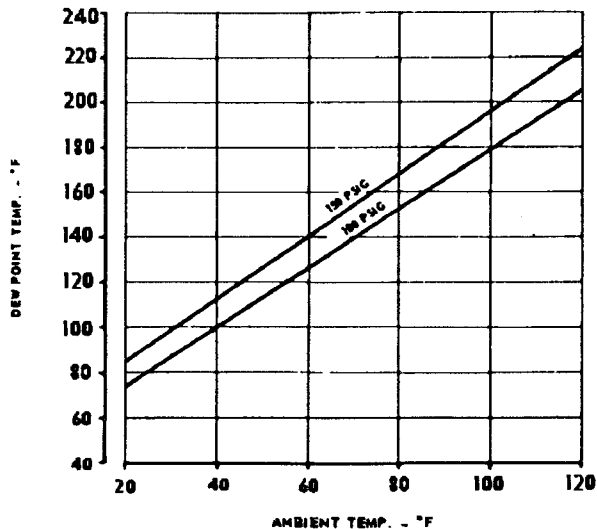

FIGURE 4-5 - DEW POINT TEMPERATURE VS. AMBIENT TEMPERATURE (100% RELATIVE HUMIDITY)

After the unit is warmed up, mixing valve maintains oil injection temperature into the compressor at a minimum of 170°F. This system provides proper compressor warm-up and prevents moisture contamination of the oil.

To check element, heat in oil - it should be fully extended at 170° F. If unit shuts down due to high air discharge temperature, the cause may be that the element is stuck open to the bypass, in which case bypass lines (Figure 1-5, page 1, this section) will be hot to touch and lines out of mixing valve much cooler. When flushing the oil system, remove mixing valve and clean all parts thoroughly.

OIL RESERVOIR - The oil reservoir-separator combines multiple functions into one vessel. The lower half is the oil reservoir, providing oil storage capacity for the system and the top portion, a primary oil separation means. The reservoir also provides limited air storage for control and gauge actuation.

COMPRESSOR OIL SEPARATOR located above the oil reservoir features a renewable spin-on type separator element and provides the final removal of oil from the air flow.

Oil carry-over through the service lines may be caused by a faulty oil separator, overfilling of the oil reservoir, oil that foams, oil return line malfunction, or water condensate in the oil. If oil carryover occurs, inspect the separator only after it is determined that the oil level is not too high, the oil is not foaming excessively, the oil return tube from the bottom of the separator to the compressor cylinder is not clogged or pinched off, the check valve in the oil return is functioning properly, and there is not water or an oil/water emulsion in the oil.

Oil carry-over malfunctions of the oil separator are usually due to using elements too long, heavy dirt or varnish deposits caused by inadequate air filter service, use of improper oil or using oil too long for existing conditions.

Excessive tilt angle of the unit will also hamper separation and cause oil carry-over.

Oil separator element life cannot be predicted; it will vary greatly depending on the conditions of operation, the quality of the oil used and the maintenance of the oil and air filters. The condition of the separator can be determined by pressure differential or by inspection.

Pressure Differential Gauging - The "CHANGE SEPARATOR" message will flash when the pressure differential across the oil separator reaches approximately 8 PSI. Replace the oil separator element at this time. If ignored, the unit will shut down and the display will indicate shutdown and the change separator LED will be on when the pressure differential reaches 15 PSI.

To measure the pressure differential, see "Pressure and Temperature Digital Readouts" in Section 4, page 4. Simply subtract the downstream reading from the upstream reading.

CAUTION

Using an oil separator element at excessive pressure differential can cause damage to equipment. Replace separator when "Change Separator" message flashes.

NOTICE

A sudden drop to zero pressure differential or sudden heavy oil carryover may indicate a ruptured element.

Inspection - After removal of separator element, shine a light inside the element to reveal areas of heavy dirt or varnish deposits or breaks (ruptures) in element media.

Removal Of Oil Separator For Inspection Or Replacement:

DANGER

Air/oil under pressure will cause severe personal injury or death. Shut down compressor and relieve system of all pressure before removing valves, caps, plugs, fittings, bolts, and filters.

1. Be certain unit is off and all system pressure is relieved.
2. At the bottom of the separator, disconnect the oil return (scavenge) tube and remove tube elbow.

3. Remove spin-on element.
4. Clean gasket seating surface of head.
5. Inspect and/or replace the separator as necessary. Before reassembly, coat the separator element gasket with the same lubricant used in the unit.
6. Screw on until gasket makes contact. Hand tighten 1/3 to 1/2 turn extra..
7. Reinstall tube elbow and oil return tube..
8. Run the unit and check for leaks.

COMPRESSOR OIL SYSTEM CHECK - The following readings are based on ambient temperature of 80°F with the system in good condition. Compressor should be at operating temperature at the time of checks. One-half hour of loaded operation is usually sufficient to reach level-out operating temperatures.

Air and Oil Discharge Temperature - 170° to 200° F - Read at gauge on the instrument panel or check with a

thermometer at the discharge housing.

Compressor Oil Inlet Temperature - 165° to 175° F - Install tee at oil filter outlet and check with thermometer.

Oil Inlet Pressure - Check at the fitting in the line near the compressor oil inlet. With air receiver pressure at 100 psi, oil inlet pressure should be 65-75 psig.

Oil Cooler Oil Pressure Differential (Air-Cooled Radiator) - Check differential across oil system by measuring oil inlet pressure as described above.

Oil Cooler Temperature Differential (Air-Cooled Radiator) - The oil temperature differential depends on the temperature of the air at the oil cooler fan and cleanliness of the core faces. As ambient temperatures and core restrictions increase, the oil cooler outlet temperature will increase. The oil inlet temperature is approximately the same as the air discharge temperature - see the gauge on the instrument panel. The outlet oil temperature may be checked by installing a tee at the oil filter outlet.

SECTION 6 AIR FILTER

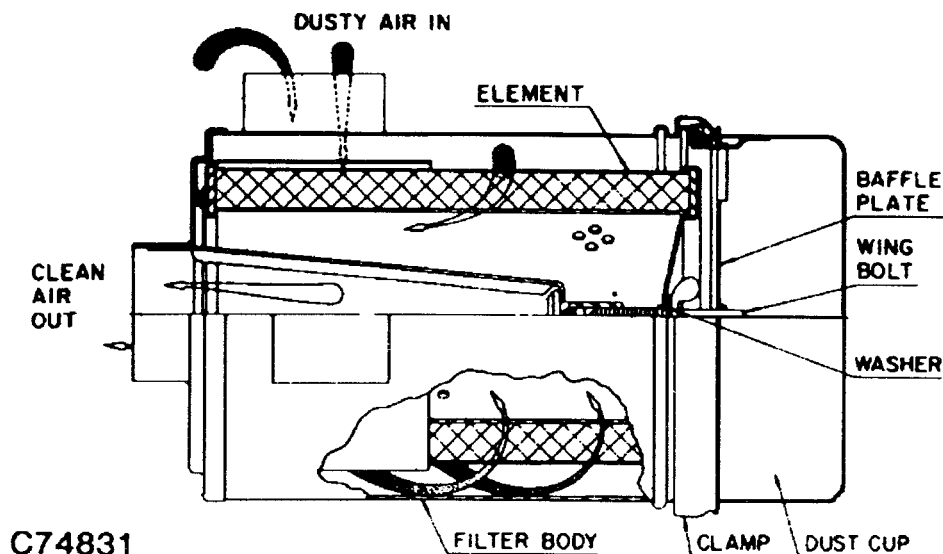

FIGURE 1-6 - HEAVY DUTY AIR FILTER (STANDARD)

HEAVY-DUTY AIR FILTER (Figure 1-6) furnished as standard equipment on units with an enclosure is a heavy-duty washable element dry type air filter. The air filter must receive proper maintenance if maximum service is to be obtained from the unit. Establishing adequate and timely filter service is **MOST IMPORTANT**. Improperly maintained air filter can cause a loss of compressor air delivery.

Dust Cup - Service every 4 to 120 hours depending on dust conditions. To service, loosen the retaining band clamp and remove the dust cup. Do not wash the dust cup - wipe clean with a clean dry cloth. Do not bend the edge of the cup by striking on a hard surface. When installing dust cup, make sure clamp is securely tightened to prevent leakage.

Filter Element - Service the air filter element when the "CHANGE AIR FILTER" LED is illuminated. Clean every 50 to 150 operating hours depending on dust conditions.

NOTICE

Use only genuine Gardner-Denver air filter elements on Gardner-Denver compressor units. Genuine parts are available through your authorized Gardner-Denver distributor.

To service:

1. Loosen retaining band clamp and remove the dust

cup from the body of the filter.

2. Visually inspect the element in place. If cleaning is not necessary, reinstall the dust cup on the filter. If the element requires cleaning, unscrew the wing bolt and withdraw the element from the body.
3. Wash the element by soaking about 15 minutes in warm water with a mild nonsudsing detergent. Rinse the element thoroughly with clean water; a hose may be used if the water pressure does not exceed 40 psig.
4. Inspect the element for ruptures or cracks in the pleated media; replace the element if any are found. Inspect the gasket on the bottom (outlet end) of the element; replace the entire element if the gasket is damaged, a spare element will keep down time to a minimum.
5. Allow the element to air dry **COMPLETELY**. Do not expose the element to heat over 150° F. Install the element in the filter body and fasten securely with the wing bolt. Reinstall the dust cup and retaining band clamp. Make sure the clamp is tightened securely to prevent leakage.

WARNING

Do not oil this element. Do not wash in inflammable cleaning fluids. Do not use solvents other than water. Improper cleaning may damage element.

CAUTION

Never operate the unit without the element. Never use elements that are damaged, ruptured or wet. Never use gaskets that won't seal. Keep spare elements and gaskets on hand to reduce downtime. Store elements in a protected area free from damage, dirt and moisture. Handle all parts with care.

Filter Element Life - The element should be replaced after six (6) cleanings or if:

1. Visual inspection indicates a rupture, crack or pin

hole in the pleated media. Inspection should be done by placing a bright light inside the element.

2. Pressure drop through a filter with a freshly cleaned element is below three (3) inches of water with compressor running at full load - this would indicate a rupture or crack.

Inlet Screen and Tube - Inspect the inlet screen and tube for dirt accumulation each time the filter is serviced. Clean the tube when required by ramming a clean dry cloth through the tube. Wipe the inside of the filter body to remove any dirt falling from the inlet tube before reinstalling the element.

Causes of short element life include: severe dust conditions, infrequent servicing, improper cleaning, or contamination by oil or chemical fumes.

**SECTION 7
BELT DRIVE**

Proper drive belt tension and alignment are provided at the factory, however, good practice dictates checking the drive alignment and tension after shipment and before initial start-up. Sheaves should align straight across the front with a straight edge. The best tension is just enough tension to keep belts from "squealing" on start-up.

CAUTION

Excessive belt tension can damage the equipment. Tension the belts as shown in Table 1-7.

Belts can be changed when necessary by first removing the wire guard. Then loosen, but do not remove, the four motor foot nuts. Next, use the adjusting screws in the motor base to loosen belt tension. Remove the belts over the fan.

CAUTION

Interference between the fan and the orifice can damage equipment. Be certain the orifice has even clearance around the fan before starting the unit.

CHECKING BELT TENSION - Using a spring scale, apply a perpendicular force to each belt at the midpoint of the span and measure the deflection. Correct deflection force and deflection are shown in Table 1-7. To tighten belts, merely increase the center distance.

NOTICE

When a new set of belts is installed on a drive, the initial deflection force should be 1/3 greater than shown in Table 1-7. Recheck tension frequently during the first 24 hours of operation.

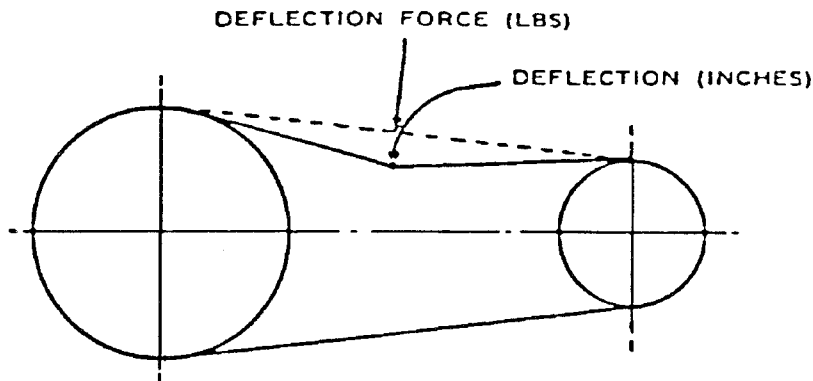

Motor H.P.	No. Of Belts	Deflection Force Pounds (per belt)	Deflection In Inches
15	4	6 - 8.5	5/16
20	4	6 - 7	5/16
25	4	6 - 8.5	5/16
30	4	6 - 7	5/16

TABLE 1-7 - BELT TENSION 3VX BELTS

SECTION 8 MAINTENANCE SCHEDULE

SERVICE CHECK LIST -

Air Filter - Operating conditions determine frequency of service. The "CHANGE AIR FILTER" display will flash to signal that the air filter requires servicing or changing. See "Air Filter," Section 6.

Oil Separator - Operating conditions determine frequency of service. The "CHANGE SEPARATOR" display will flash to signal that oil separator element requires changing. See "Compressor Oil Separator" in Section 5.

Refer to "Compressor Oil Separator" in Section 5 for further details.

Motor Lubrication - Refer to Section 2 and Maintenance Schedule Chart below.

Every 8 Hours Operation

1. Check the reservoir oil level - add oil if required. See Section 5. If oil consumption is high, refer to "Excessive Oil Consumption" in Section 9.
2. Observe if the unit loads and unloads properly.
3. Check discharge pressure and temperature.
4. Drain the moisture trap in the control system. See Section 4.
5. Check Panel LED's for advisories.

Every 125 Hours Operation

1. Check for dirt accumulation on oil/aftercooler core faces and the cooling fan. If cleaning is required, clean the exterior fin surfaces of the cores by blowing compressed air carrying a nonflammable safety solvent in a direction opposite that of the cooling fan air flow. This cleaning operation will keep the exterior cooling surfaces clean and ensure effective heat dissipation.

Every 1000 Hours Operation

1. Change oil filter element.

Every 4000 Hours Operation

1. Inspect oil separator element. See Section 5.

Every 6000 Hours Operation

1. Change the compressor lubricant. **UNDER ADVERSE CONDITIONS, CHANGE MORE FREQUENTLY** (refer to "Oil Change Interval" in Section 5). Flush system if required.

Every Year

1. Check the relief valve for proper operation. See Section 4.

MAINTENANCE SCHEDULE (See detail notes above)

Maintenance Action	If Panel LED is Lit	Every 8 Hours	Every 125 Hours	Every 1000 Hours	Every 4000 Hours	Every 6000 Hours	Every Year
Change Air Filter	•						
Change Oil Separator	•						
Check Reservoir Oil Level		•					
Check For Proper Load/Unload		•					
Check Discharge Pressure/Temp.		•					
Check Dirt Accumulation on Cooler			•				
Change Oil Filter Element				•			
Inspect Oil Separator Element					•		
Change Compressor Lubricant (AEON 4000)						•	
Check Relief Valve							•

* See Continuous Operating Temperature Chart for specific lubricant life.

SECTION 9 TROUBLE SHOOTING

Symptom	Possible Cause	Remedy
Compressor fails to start.	<ol style="list-style-type: none">1. Wrong lead connections.2. Blown fuses in control box.3. Motor starter overload heaters tripped.4. Pressure in reservoir.5. Read error message on control panel. See Section 4.	<ol style="list-style-type: none">1. Change leads.2. Replace fuse.3. Reset and investigate cause of overload.4. Inspect blowdown valve and muffler.5. Replace switch.
Compressor starts but stops after a short time.	<ol style="list-style-type: none">1. High discharge temperature.2. High discharge temperature switch malfunction.3. Blown fuse in starter/control box.4. Motor starter overload heaters trip.	<ol style="list-style-type: none">1. See "High Discharge Air Temperature" in this section.2. Replace switch.3. Replace fuse (investigate if fuses continue to blow).4. Reset and investigate cause of overload.
Compressor does not unload (or load).	<ol style="list-style-type: none">1. Improperly adjusted control.2. Air leak in control lines.3. Restricted control line.4. Subtractive pilot or blow-down valve malfunction.	<ol style="list-style-type: none">1. Refer to Section 4 and adjust control.2. Determine source of leak and correct.3. Clean control lines.4. Repair, clean or replace valve.

Symptom	Possible Cause	
Compressor cycles from load to unload excessively.	<ol style="list-style-type: none"> 1. Insufficient receiver capacity. 2. Restriction in control tubing. 3. Subtractive pilot setting too high. 	<ol style="list-style-type: none"> 1. Increase receiver size. 2. Inspect and clean control tubing. 3. Adjust valve. See Section 4.
Compressor is low on delivery and pressure.	<ol style="list-style-type: none"> 1. Restricted air filter. 2. Sticking inlet valve. 3. Subtractive pilot or unload pressure adjusted too low. 4. Minimum pressure valve stuck closed. 	<ol style="list-style-type: none"> 1. Clean or replace filter. 2. Inspect and clean inlet valve. 3. Adjust valve or unload pressure. See Section 4. 4. Replace valve.
High discharge air temperature.	<ol style="list-style-type: none"> 1. Thermostatic mixing valve stuck open. 2. Dirty or clogged cooler face. 3. Insufficient cooling air flow. 4. Clogged oil filter or cooler (interior). 5. Low Compressor oil. 	<ol style="list-style-type: none"> 1. Repair or replace valve. 2. Clean cooler. 3. Provide unrestricted supply of cooling air. 4. Replace filter or clean cooler. 5. Add oil to proper level.
Excessive Oil Consumption	<ol style="list-style-type: none"> 1. Oil carryover through lines. 2. Oil leaks at all fittings and gaskets. 	<ol style="list-style-type: none"> 1. See "Oil Carryover in this section. 2. Tighten or replace fittings or gasket.

Symptom	Possible Cause	Remedy
Oil Carry-Over	1. Overfilling the reservoir.	1. Drain excess oil from system.

DANGER

Air/oil under pressure will cause severe personal injury or death. Shut down compressor and relieve system of all pressure before removing valves, caps, plugs, fittings, bolts, and filters.

- | | |
|--|--|
| 2. Clogged, broken or loose oil return lines | 2. Tighten or replace faulty lines. |
| 3. Ruptured oil separator element. | 3. Replace element. |
| 4. Loose assembly. | 4. Tighten all fittings and gaskets. |
| 5. Foam caused by use of incorrect oil. | 5. Use Gardner-Denver® AEON 4000 or 9000 Lubricating Coolant. |
| 6. Inoperative minimum pressure valve. | 6. Replace valve. |
| 7. Operation at elevated discharge temperatures. | 7. Reduce temperature. See High Discharge Air Temperature - in this section. |
| 8. Scavenge line check valve failure. | 8. Replace check valve. |
| 9. Water condensate in oil. | 9. Check oil reservoir temp and if low change thermal mixing valve element to higher temp. |

NOTICE

Gardner-Denver factory remanufactured replacement compressor air end units are available from your authorized distributor, on an exchange basis, for all rotary screw compressor units.

Symptom	Possible Cause	Remedy
"CHANGE SEPARATOR" light (Flashing or on steadily) <u>ON STARTUP</u>	1. Separator differential is greater than 8 psid (.5 Bars).	1. Change Separator.
	2. Bad Transducer.	2. Verify readings with mechanical gauges. If defective, replace with 88H198.
	3. Misadjusted minimum pressure valve.	3. Set minimum pressure valve at 65 psig (4.5 Bars).
	4. Sticky minimum pressure valve.	4. Disassemble and clean.
	5. Defective minimum pressure valve. [Won't set at 65 psig (4.5 Bars)]	5. Rebuild or replace.
"CHANGE SEPARATOR" light (Flashing or on steadily) <u>WHILE RUNNING</u>	1. Separator differential is greater than 8 psid (.5 Bars).	1. Change Separator.
	2. Electrical noise creating false readings.	2. Make sure transducer wires are kept to a minimum length and are twisted.
	3. Oil reservoir is overfilling.	3. Fill to proper level (top of lower sight gauge). See Service Memo #246.
	4. Unit is rapidly cycling.	4. Adjust subtractive pilot. See Service Memo #248. (Add subtractive pilot if unit does not have one.)
	5. Defective transducer.	5. Verify readings with mechanical gauges. If defective, replace with 88H198.
	6. Plugged aftercooler, due to freezing or varnishing.	6. Clean or replace aftercooler.
	7. Oil reservoir shotgun improperly located.	7. Call factory for specifications.
"MOTOR OVERLOAD" shutdown.	1. Running compressor at a pressure over nameplate pressure.	1. Lower pressure to nameplate.
	2. Incoming voltage low or high.	2. Consult your power company.
	3. Imbalanced voltage (check phase to phase).	3. If imbalance exceeds 5%, check incoming power.

Symptom	Possible Cause	Remedy
"MOTOR OVERLOAD" shutdown. (cont.)	4. Imbalanced amps.	4. Rotate 3 phase power leads. If the high reading stays on the same leg, the problem is with the motor. If the high reading moves with the lead, the problem is with the incoming power.
	5. Incorrect motor overload setting.	5. Set overload to motor name-plate amps.
"CHANGE AIR FILTER" light on.	1. Dirty air filter.	1. Clean or replace.
"CHANGE AIR FILTER" light on, and <u>WILL NOT RESET.</u>	1. Faulty vacuum switch.	1. Measure the AC voltage between wire number 7 and connector #6 at board. If the reading is zero, replace the vacuum switch.
	2. Control board fault.	2. Measure the AC voltage between wire number 7 and connector #6 at board. If the reading is 24 volts, replace the control board.
"MOTOR OVERLOAD" shutdown. (<u>RELAY NOT TRIPPED</u>)	1. Loose connections.	1. Measure the AC voltage between wire number 5 and connector #6 at board. If the reading is zero, tighten the connections.
	2. Control board fault.	2. Measure the AC voltage between wire number 5 and connector #6 at board. If the reading is 24 volts, replace the control board.
"EO4", Emergency Stop will not clear.	1. Loose connections or faulty switch.	1. Tighten connection or repair or replace switch.
	2. Control board fault.	2. Measure the AC voltage between wire number 3 and connector #6 at board. If the reading is 24 volts, replace the control board.
	3. Contact block not properly installed.	3. Ensure contact block is fully snapped into left or right (not center) slot of switch operator.

Symptom	Possible Cause	Remedy
<p>Erroneous Pressure Readings [135 - 150 psig constantly]. (9.3 - 10.3 Bars)</p>	<ol style="list-style-type: none"> 1. Electrical noise creating false readings. 2. Loose connector. 3. Bad transducer. 	<ol style="list-style-type: none"> 1. Make sure transducer wires are kept to a minimum length and are twisted. 2. Measure the DC voltage between the white and black wires of the corresponding transducer at the control board with zero pressure on the transducer. If .460 to .540 volts, replace the plug-gable connector that connects transducers to the board. 3. Measure the DC voltage between the white and black wires of the corresponding transducer at the control board with zero pressure on the transducer. If 3.10 to 3.60 volts, replace the transducer.
<p>Oil leat at the bottom of the seal housing.</p>	<ol style="list-style-type: none"> 1. Gasket leaking. 2. Plug leak. 3. Capscrew leaking. 4. Shaft seal leaking. 	<ol style="list-style-type: none"> 1. Replace the gasket. 2. Repair. 3. Repair. 4. Change seal. Determine if the seal is Type 21, Part No. 00519056 0028/25 or Type 2, Part No. 60DD59. If it is the Type 2, please call Factory Service with the details. 1-217-222-5400. See Service Memo #224 for proper seall replacement procedures.
<p>Fuse on board blows.</p>	<ol style="list-style-type: none"> 1. Bad board. 2. Shorted coils on hour meter, starter coil, or blowdown valve. 	<ol style="list-style-type: none"> 1. Remove all power from the unit by opening the main disconnect, replace fuse, energize main power. If fuse blows - replace board. 2. If fuse does not blow, check for shorted coils.



Gardner-Denver
Industrial Machinery

WARRANTY ROTARY SCREW COMPRESSORS OIL INJECTED • OIL FREE

GENERAL PROVISIONS AND LIMITATIONS

Gardner-Denver Industrial Machinery Division (the "Company") warrants to each original retail purchaser ("Purchaser") of its new products from the Company or its authorized distributor that such products are, at the time of delivery to the Purchaser, made with good material and workmanship. No warranty is made with respect to:

1. Any product which has been repaired or altered in such a way, in the Company's judgment, as to affect the product adversely.
2. Any product which has, in the Company's judgment, been subject to negligence, accident, improper storage, or improper installation or application.
3. Any product which has not been operated or maintained in accordance with the recommendations of the Company.
4. Components or accessories manufactured, warranted and serviced by others.
5. Any reconditioned or prior owned product.

Claims for items described in (4) above should be submitted directly to the manufacturer.

WARRANTY PERIOD

The Company's obligation under this warranty is limited to repairing or, at its option, replacing, during normal business hours at an authorized service facility of the Company, any part which in its judgment proved not to be as warranted within the applicable Warranty Period as follows.

COMPRESSOR AIR ENDS

Compressor air ends, consisting of all parts within and including the compressor cylinder and gear housing, are warranted for 24 months from date of initial use or 27 months from date of shipment to the first purchaser, whichever occurs first.

Any disassembly or partial disassembly of the air end, or failure to return the "unopened" air end per Company instructions, will be cause for denial of warranty.

OTHER COMPONENTS

All other components are warranted for 12 months from date of initial use or 15 months from date of shipment to first purchaser, whichever occurs first.

LABOR TRANSPORTATION AND INSPECTION

The Company will provide labor, by Company representative or authorized service personnel, for repair or replacement of any product or part thereof which in the Company's judgment is proved not to be as warranted. Labor shall be limited to the amount specified in the Company's labor rate schedule.

Labor costs in excess of the Company rate schedules caused by, but not limited to, location or inaccessibility of the equipment, or labor provided by unauthorized service personnel is not provided by this warranty.

All costs of transportation of product or parts claimed not to be as warranted and, of repaired or replacement parts to or from such service facility shall be borne by the Purchaser. The Company may require the return of any part claimed not to be as warranted to one of its facilities as designated by Company, transportation prepaid by Purchaser, to establish a claim under this warranty.

Replacement parts provided under the terms of this warranty are warranted for the remainder of the Warranty Period of the product upon which installed to the same extent as if such parts were original components.

WARRANTY REGISTRATION VALIDATION

A warranty registration form is provided with each machine. The form must be completed by the Purchaser and mailed within ten days after machine start-up to validate the warranty.

DISCLAIMER

THE FOREGOING WARRANTY IS EXCLUSIVE AND IT IS EXPRESSLY AGREED THAT, EXCEPT AS TO TITLE, THE COMPANY MAKES NO OTHER WARRANTIES, EXPRESSED, IMPLIED OR STATUTORY, INCLUDING ANY IMPLIED WARRANTY OF MERCHANTABILITY.

THE REMEDY PROVIDED UNDER THIS WARRANTY SHALL BE THE SOLE, EXCLUSIVE AND ONLY REMEDY AVAILABLE TO THE PURCHASER AND IN NO CASE SHALL THE COMPANY BE SUBJECT TO ANY OTHER OBLIGATIONS OR LIABILITIES. UNDER NO CIRCUMSTANCES SHALL THE COMPANY BE LIABLE FOR ANY SPECIAL, INDIRECT, INCIDENTAL OR CONSEQUENTIAL DAMAGES, EXPENSES, LOSSES OR DELAYS HOWSOEVER CAUSED.

No statement, representation, agreement or understanding, oral or written, made by any agent, distributor, representative, or employee of the Company which is not contained in this Warranty will be binding upon the Company unless made in writing and executed by an officer of the Company.

This warranty shall not be effective as to any claim which is not presented within 30 days after the date upon which the product is claimed not to have been as warranted. Any action for breach of this warranty must be commenced within one year after the date upon which the cause of action occurred.

Any adjustment made pursuant to this warranty shall not be construed as an admission by the Company that any product was not as warranted.



Gardner-Denver Industrial Machinery

For additional information, contact Gardner-Denver Industrial Machinery
Division, 1800 Gardner Expressway, Quincy, Illinois 62305-4024
Telephone (217) 224-8800 FAX 217-224-7814 Telex 404332.

Specifications subject to change without notice.

COPYRIGHT © 1992 Cooper Industries, Inc.

Litho in USA. 25C-5-92