GARDNER DENVER®

13-10-504
2Nd Edition

**ELECTRA-SAVER®
STATIONARY SCREW
COMPRESSOR**

MODELS

350 HP

EAYQS , EAYSS, (EAYPSC)

400 HP

EAYQT, EAYST, (EAYPTC)

500 HP

EAYQV, EAYSV, (EAYPVC)

PARTS LIST

Gardner

Denver

TABLE OF CONTENTS

Group Name	350, 400, 500 HP
Ordering Instructions	Page 2
Introduction Page	Page 2
Thirteen Character Model Designations	Page 3
Compressor, Bare	Pages 4 & 5
Turn Valve, Oil Seal	
Compressor Repair Kits (Selective)	Page 6
Compressor Tubing Group	Page 7
Turn Valve Actuator & Mounting Group	Page 8
Actuator Valve & Mounting Group	Page 9
Compressor Inlet Valves & Mounting Group	Page 10
Inlet Valve (Component Parts)	Page 11
Purge Valve & Mounting Group	Page 12
Oil Reservoir Group	Page 13
Air Discharge Piping	Page 14
Oil Reservoir Group (Selective Items)	Page 15
Relief Valve & Oil Separator Repair Kits	
Oil Piping Group (Air-Cooled & Water-Cooled Units)	Page 16
Heat Exchanger Group (Water-Cooled Units) (350 & 450 HP Units)	Page 17
Heat Exchanger Group (Water-Cooled Units) (500 HP)	Page 18
Aftercooler & Mounting Group (Water-Cooled Units) (Optional Equipment)	Page 19
Water-Cooled Selective Items:	
Fresh Water Service	Page 20
Salt Water Service	Page 21
Heat Exchanger, Temperature Regulator, Water Valve & Aftercooler	
Oil Filter, Minimum Pressure Valve & Mixing Valve (Component Parts)	Page 22
Coupling (Compressor to Motor) & Miscellaneous Tube Fittings	Page 23
Motor Mounting & Coupling (Selective)	Page 24
Base & Mounting Groups	Page 25
Aftercooler Module (500 HP Only)	Page 26
Control Components & Tubing	Page 27
Subtractive Pilot (Component Parts)	Page 28
Oil Reservoir Pressure Switch	Page 29
Control Panels (Front & Back)	Pages 30 & 31
Control Items (Selective)	Page 32
Tubing Schematic (Air & Oil)	Page 33
Enclosure Group (With Air Filter)	Pages 34 & 35
Recommended Spare Parts Kits	Pages 36 & 37

NOTE: Groups not identified by HP are suitable for use on all units. On groups where HP is shown, select proper page when ordering repair parts.

**MAINTAIN COMPRESSOR RELIABILITY AND PERFORMANCE WITH
GENUINE GARDNER-DENVER AND JOY COMPRESSOR
PARTS AND SUPPORT SERVICES**

Gardner-Denver and Joy Compressor genuine parts, engineered to original tolerances, are designed for optimum dependability — specifically for Gardner-Denver and Joy compressor systems. Design and material innovations are the result of years of experience with hundreds of different compressor applications. Reliability in materials and quality assurance are incorporated in our genuine replacement parts.

Your authorized Gardner-Denver and Joy Compressor distributor offers all the backup you'll need. A worldwide network of authorized distributors provides the finest product support in the air compressor industry.

Your local authorized distributor maintains a large inventory of genuine parts and he is backed up for emergency parts by direct access to the Gardner-Denver Industrial Machinery Master Distribution Center (MDC) in Memphis, Tennessee.

Your authorized distributor can support your Gardner-

Denver or Joy air compressor with these services:

1. Trained parts specialists to assist you in selecting the correct replacement parts
2. Factory warranted new and remanufactured rotary screw air ends. Most popular model remanufactured air ends are maintained in stock at MDC for purchase on an exchange basis with liberal core credit available for the replacement unit.
3. A full line of factory tested AEON™ compressor lubricants specifically formulated for use in Gardner-Denver and Joy compressors.
4. Repair and maintenance kits designed with the necessary parts to simplify servicing your compressor.

Authorized distributor service technicians are factory-trained and skilled in compressor maintenance and repair. They are ready to respond and assist you by providing fast, expert maintenance and repair services.

For the location of your local authorized Gardner-Denver and Joy Air Compressor distributor refer to the yellow pages of your phone directory or contact:

**Distribution Center:
Gardner-Denver Industrial Machinery
Master Distribution Center
5585 East Shelby Drive
Memphis, TN 38115
Phone: (901) 363-6100
Fax: (901) 393-1095**

**Factory:
Gardner-Denver Industrial Machinery
1800 Gardner Expressway
Quincy, IL 62301
Phone: (217) 222-5400
Fax: (217) 2235897**

INSTRUCTIONS FOR ORDERING REPAIR PARTS

When ordering parts, specify Compressor **MODEL**, Method of Cooling, **HORSEPOWER** and **SERIAL NUMBER** (see nameplate on unit). Serial Number is also stamped on top of the cylinder flange to the right of the inlet housing.

All orders for Parts should be placed with the nearest authorized distributor.

Where NOT specified, quantity of parts required per

compressor or unit is one (1); where more than one is required per unit, quantity is indicated in parenthesis. **SPECIFY EXACTLY THE NUMBER OF PARTS REQUIRED.**

DO NOT ORDER BY SETS OR GROUPS.

To determine the Right Hand and Left Hand side of a compressor, stand at the motor end and look toward the compressor. Right Hand and Left Hand are indicated in parenthesis following the part name, i.e. (RH) & (LH).

AIR ENDS

NOTE: Factory warranted new and rebuilt air ends are available from your authorized Gardner-Denver and Joy Compressor Distributor.

Electra-Saver® Stationary Screw Compressor
350 HP - 400 HP - 500 HP
Thirteen Character Model Designations

Notice to Customer – To find the construction options for your compressor unit, fill in the balance of letters from your compressor name plate.

E A Y

COLUMN NUMBER

1 2 3 4 5 6 7 8 9 10 11 12 13

Follow the line down and over from each letter thus filled in to find the appropriate construction with which your machine is equipped. The number "9" in any column space indicates "NOT APPLICABLE," the number "8" in any column space indicates SPECIAL DESIGN - REFER TO FACTORY ORDER TICKET.

COLUMNS 1, 2 & 3 - COMPRESSOR TYPE & SIZE

COLUMN 4 - TYPE OF CONSTRUCTION

- Q. Air-Cooled, Base Mounted
- S. Water-Cooled, Base Mounted

COLUMN 5 - HORSEPOWER

- S. 350HP T. 400HP V. 500 HP

COLUMN 6 - ENGINEERING SPECIFICATION

COLUMN 7 - OPERATING PRESSURE

- D. 100 PSIG (60 HZ) N. 100 PSIG (50 HZ)
- F. 125 PSIG (60 HZ) P. 125 PSIG (50 HZ)
- H. 150 PSIG (60 HZ) R. 150 PSIG (50 HZ)

COLUMN 8 - CONTROL - Letter varies with Voltage to Transformer -

Refer to pages 10, 11 & 12

A thru L - Dual Control M thru X - Duomatic Control

COLUMN 9 - CONTROL ENCLOSURE & STARTER TYPE - Letters vary with options -

Refer to pages 10, 11 & 12

- A thru D - Magnetic Starter (NEMA I)
- E thru H - Magnetic Starter (NEMA IV)
- I thru L - Manual Starter (NEMA I)
- M thru P - Manual Starter (NEMA IV)

COLUMN 10 - ENCLOSURE & AIR FILTER - Refer to page 13

A - Standard Enclosure/Standard Air Filter

COLUMN 11 - COOLERS - Letters vary with Material, Manufacturer &

Aftercooler (if used) - Refer to pages 5 & 9

- A thru H - Air Cooled
- I thru T - Fresh Water Cooled
- u thru X - Salt Water Cooled

COLUMN 12 - COOLER ELECTRICAL - Letters vary with Voltage -

Refer to pages 10, 11 & 12

- A thru I - Air Cooled NEMA I
- J thru S - Air Cooled NEMA IV
- T thru X - Water Cooled

COLUMN 13 - COMPRESSOR MOTOR DRIVE

MOTORS ARE NOT LISTED IN THIS BOOK - When ordering replacement motor for your unit, it is MOST IMPORTANT that the COMPLETE thirteen digit model number is given in order to obtain correct drive motor.

BARE COMPRESSOR

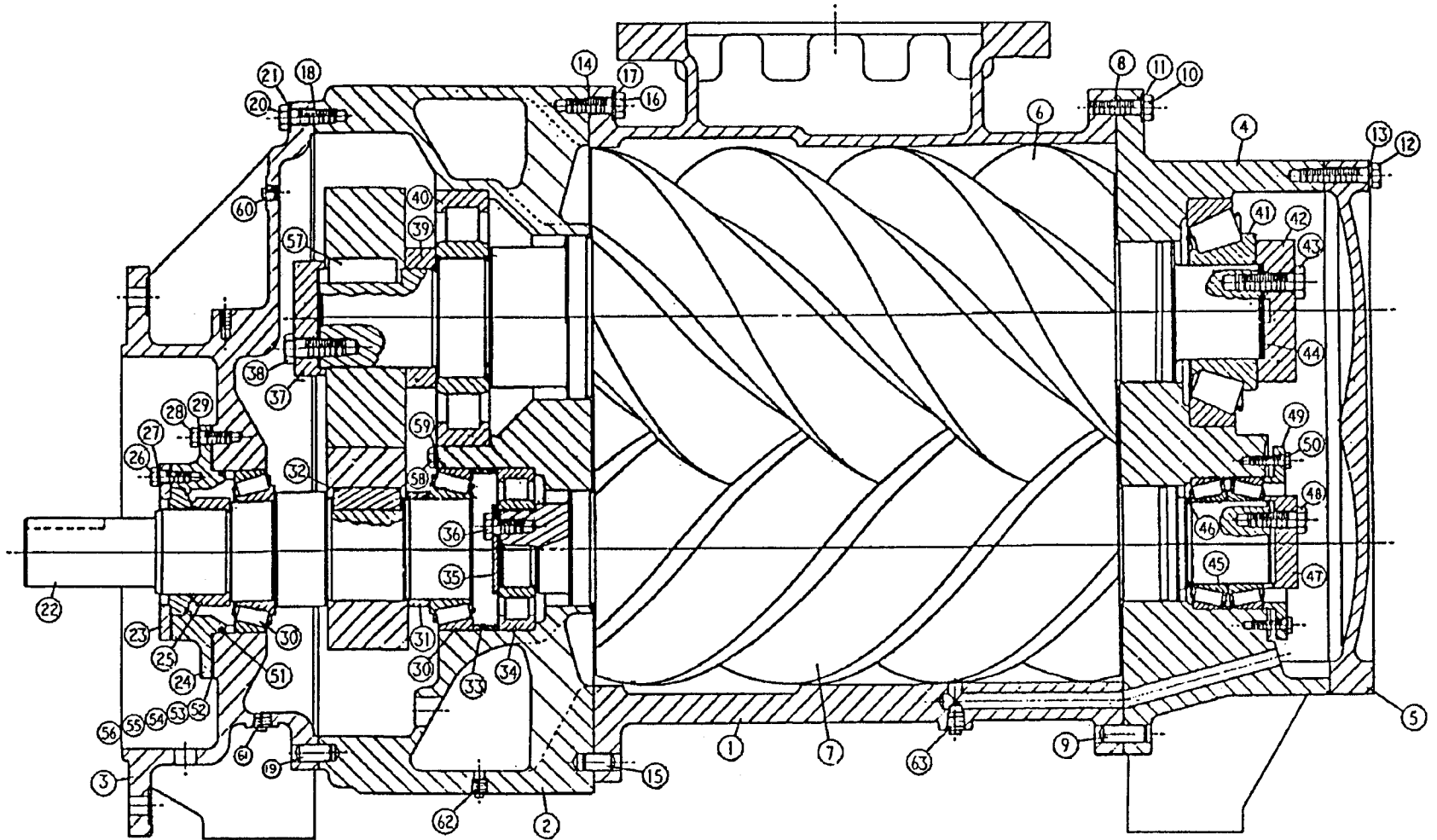

Det. No.	Name of Part	Qty	Part No.
1	CYLINDER.....	1	200SSY002
2	HOUSING-BEARING.....	1	207SSY006
3	HOUSING-GEAR.....	1	200SSY151
4	HOUSING-BEARING.....	1	208SSY00
5	COVER.....	1	200SSY225
6	ROTOR-MAIN.....	1	202SSY010
7	ROTOR-SECONDARY.....	1	203SSY010
8	GASKET.....	1	207SSY715N
9	PIN-DOWEL.....	2	26M112
10	SCREW-HEX CAP.....	26	655EF080
11	WASHER-LOCK.....	26	95B7
12	SCREW-HEX CAP.....	23	655EF110
13	WASHER-LOCK.....	23	95B7
14	GASKET.....	1	201SSY715N
15	PIN-DOWEL.....	2	62M112
16	SCREW-HEX CAP.....	30	655EF080
17	WASHER-LOCK.....	30	95B7
18	GASKET.....	1	200SSY715N
19	PIN-DOWEL.....	2	62M112
20	SCREW-HEX CAP.....	27	655EF080
21	WASHER-LOCK.....	27	95B7
22	SHAFT.....	1	200SSY050
23	PLATE-SEAL.....	1	1S1236
24	HOUSING-SEAL.....	1	200SSY362
25	SEAL-SHAFT.....	1	60BP21
26	SCREW-HEX CAP.....	6	655EE050
27	WASHER-LOCK.....	6	95B5
28	SCREW-HEX CAP.....	8	655EE050
29	WASHER-LOCK.....	8	95B5
30	BEARING-ROLLER.....	2	12BA37
31	SPACER-SHAFT.....	1	201SSY600
32	KEY-SQUARE.....	1	35L14
33	SPACER.....	1	200SSY600
34	BEARING-ROLLER.....	1	12BA4
35	PLATE-BRG. RET.	1	201SSY253
36	SCREW-HEX CAP.....	3	75A18N
37	PLATE-BRG. RET.	1	200SSY253
38	SCREW-HEX CAP.....	3	655EG08N
39	SPACER-SHAFT.....	1	202SSY600

Det. No.	Name of Part	Qty	Part No.
40	BEARING-ROLLER.....	1	12BA108
41	BEARING-ROLLER.....	1	12BA109
42	PLATE-BRG. RET.	1	204SSY253
43	SCREW-HEX CAP.....	3	655EG09N
44	SHIM-SET.....	1	77H21
45	BEARING-ROLLER.....	1	12BA107
46	SHIM.....	1	77H65
47	PLATE-BRG. RET.	1	205SSY253
48	SCREW-HEX CAP.....	3	655EF08N
49	RETAINER.....	1	200SSY205
50	SCREW-HEX CAP.....	4	655ED04N
51	O-RING.....	1	200SSY205
52	SHIM.....	8	203SSY732
53	SHIM.....	16	204SSY732
54	SHIM.....	16	205SSY732
55	SHIM.....	8	207SSY732
56	SHIM.....	8	208SSY732
57	KEY-SQUARE.....	1	35L20
58	SCREW-HEX CAP.....	2	75A68N
59	WASHER-PLAIN.....	2	95D169
60	PLUG-SQ HD PIPE.....	1	64AC4
61	PLUG-SQ HD PIPE.....	1	64AC4
62	PLUG-SQ HD PIPE.....	1	64AC2
63	PLUG-SQ HD PIPE.....	1	64AC4
*	PLUG-SQ HD PIPE.....	8	64AC2
*	PLUG-SQ HD PIPE.....	3	64AC4
*	PLUG-SQ HD PIPE.....	2	64AC3
*	ADAPTOR-FILTER.....	1	200SSY070
*	FILTER-OIL.....	1	26A43
*	NUT-HEX JAM.....	1	50G8
*	NIPPLE-PIPE.....	2	63U8X14G
*	TEE-PIPE.....	2	64G6G
*	TUBE-FORMED.....	1	201SSY857
*	CONNECTOR-TUBE.....	4	86E20
*	TUBE-FORMED.....	1	201SSY857
*	BRACKET.....	1	202SSY142
*	CLAMP.....	1	98H13
*	GASKET-RING.....	5	25F13

* Not shown.)

COMPRESSOR TUBING GROUP

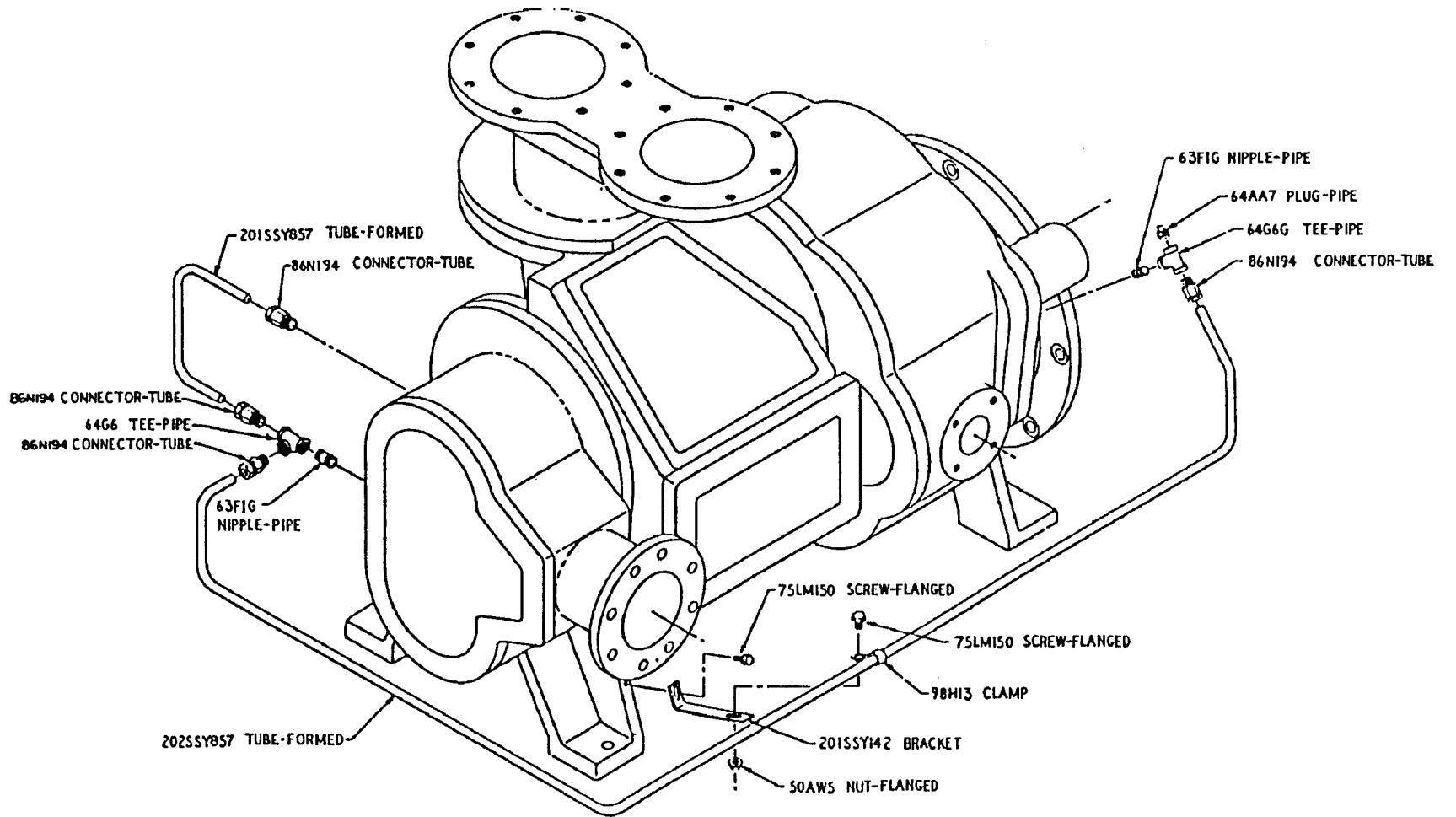

**BARE COMPRESSOR REPAIR KITS
(350, 400 & 500 HP)**

PSI	HP	MODEL	+ GEAR KIT PART NO.		BARE COMPRESSOR FIELD REPLACEMENT (INCLUDES GEARS)		*GASKET KIT PART NO.
			60 HZ	50 HZ	60 HZ	60 HZ	
100	350	ESSF (EAYPS)	SSY67337	SSY68149	EAY68413	EAY72988	EAY68420
	400	ESTF (EAYPT)	SSY67338	SSY68150	EAY68414	EAY74788	EAY68420
	500	ESVF (EAYPV)	SSY67339	SSY68151	EAY68415	EAY72990	EAY68420
125	350	ESSF (EAYPS)	SSY67363	SSY67337	EAY68412	EAY68413	EAY68420
	400	ESTF (EAYPT)	SSY67337	SSY67338	EAY68413	EAY68414	EAY68420
	500	ESVF (EAYPV)	SSY67364	SSY67339	EAY68416	EAY68415	EAY68420
150	350	ESSF (EAYPS)	SSY67363	SSY67363	EAY68412	EAY68412	EAY68420
	400	ESTF (EAYPT)	SSY67363	SSY67337	EAY68412	EAY68413	EAY68420
	500	ESVF (EAYPV)	SSY67337	SSY67364	EAY68413	EAY68416	EAY68420

+ Gear Kit includes gears, keys, seal housing o-ring, gear housing gasket and miscellaneous shims.

* Gasket Kit is for complete unit, less motor. This includes a bare compressor (only) gasket kit, part number SSY67336, which may be purchased separately.

AIR END PER H.P., HZ AND PSI

(SSYAAB) AIR END #	H.P.	PSI	HZ	(SSYAAB) AIR END #	H.P.	PSI	HZ				
01	350	100	60	04	350	125	60				
	350	125	50		350	150	60				
	400	125	60		350	150	50				
	400	150	50		400	150	60				
	500	150	60		06	500	125	60			
02	400	100	60	500		150	50				
	500	125	50	07	350	350	50				
03	500	100	60					08	400	100	50
		125	50	09	500	100	50				

TURN VALVE ACTUATOR & MOUNTING GROUP

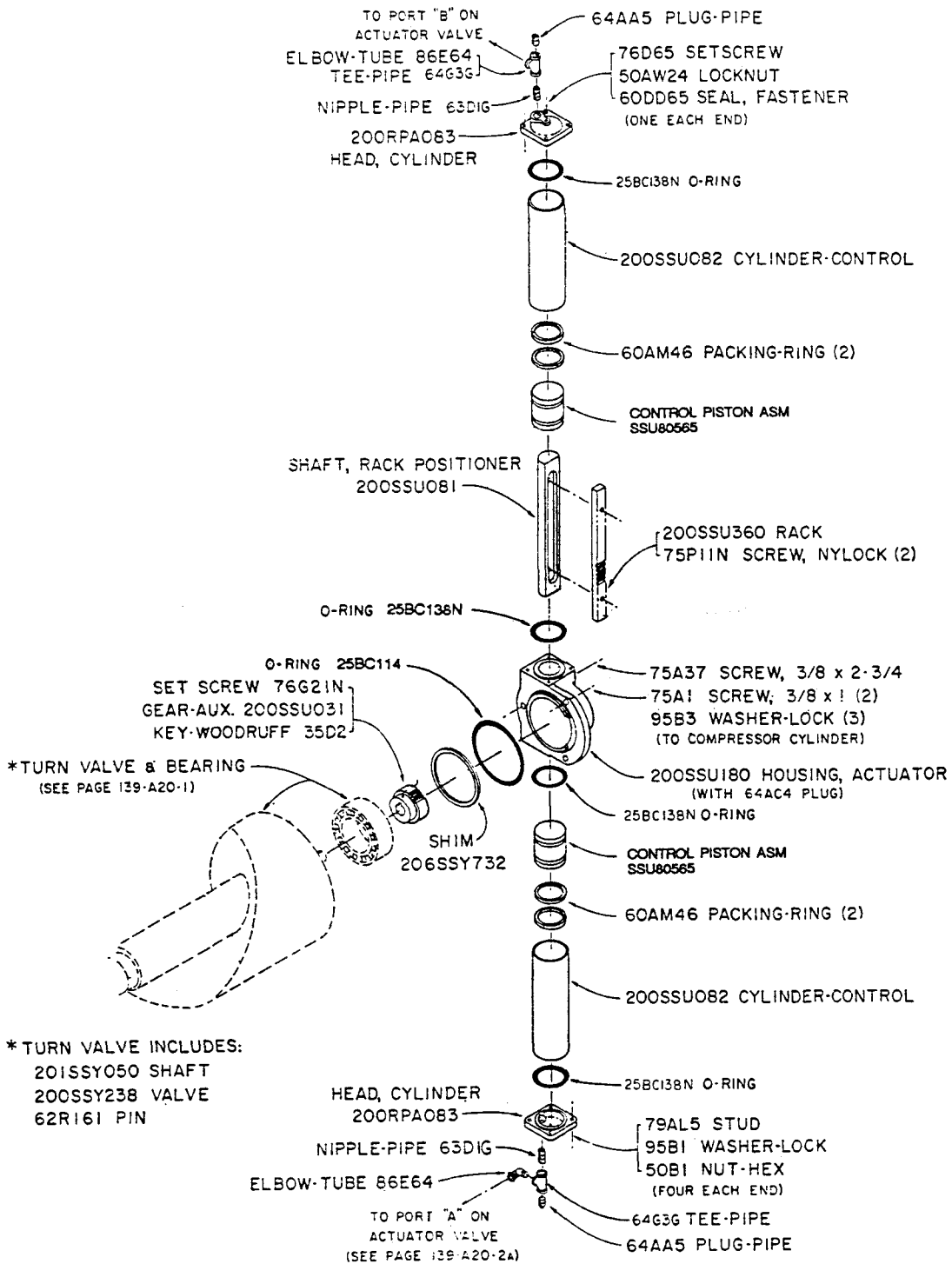

ACTUATOR VALVE & MOUNTING GROUP

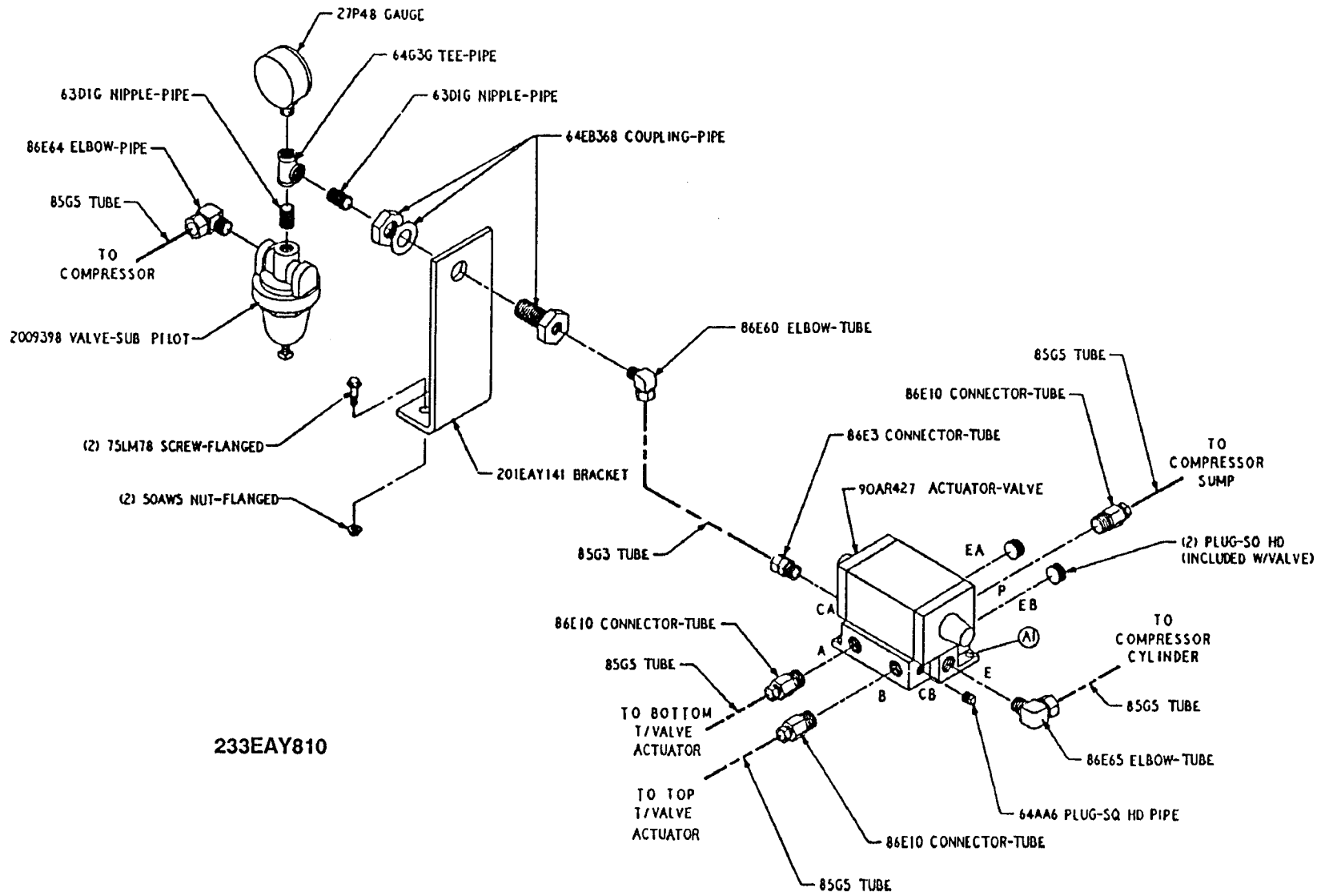

INLET VALVES & MOUNTING GROUP

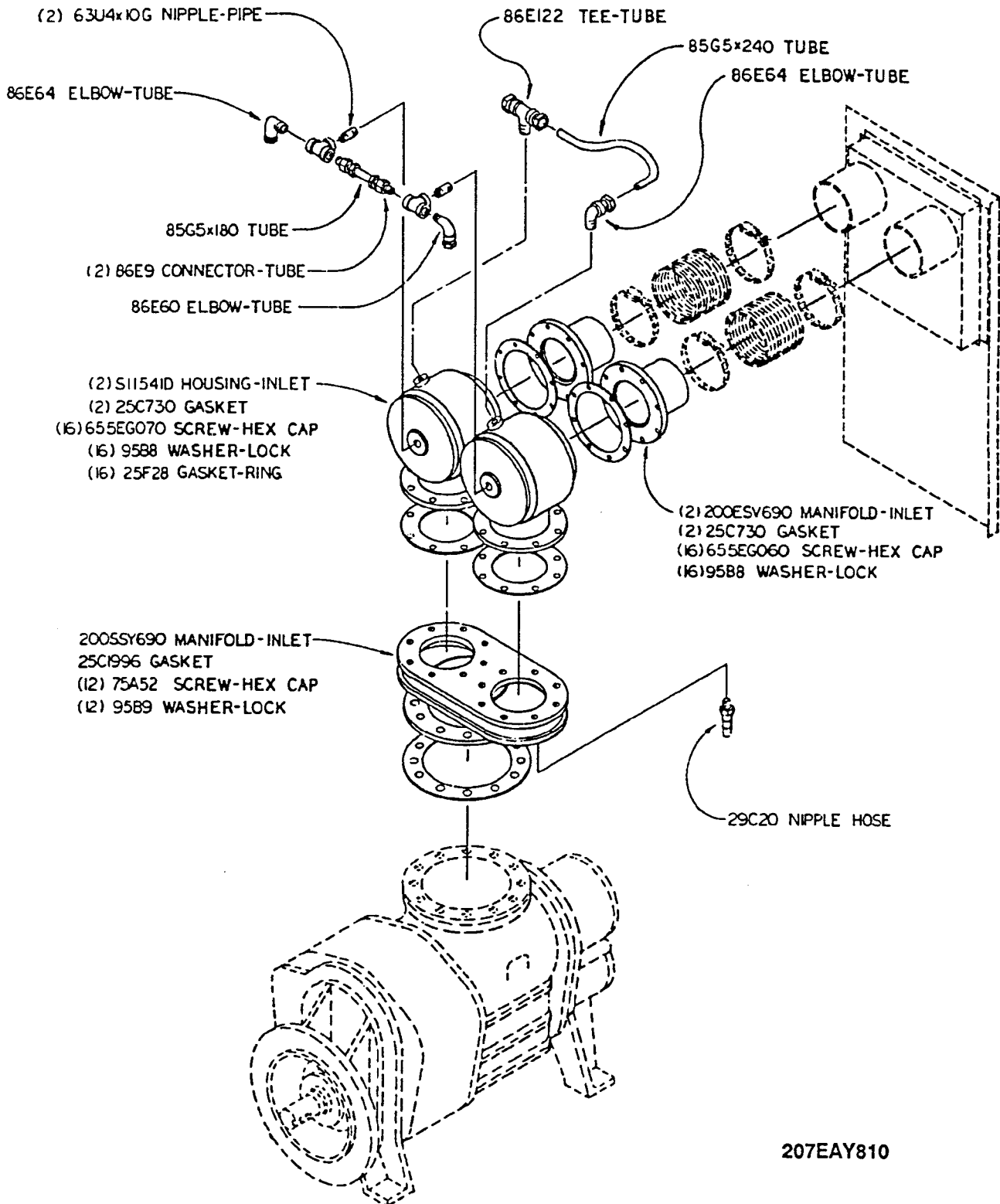

207EAY810

INLET VALVE ASSEMBLY--S11541D

- 200SSW044 VALVE-INLET
- 200SSW483 GUIDE
- 200SSW338 CLAMP-DISC
- 50E9 NUT-HEX CASTLE
- 200SSW067 DISC
- 62E30 PIN-COTTER

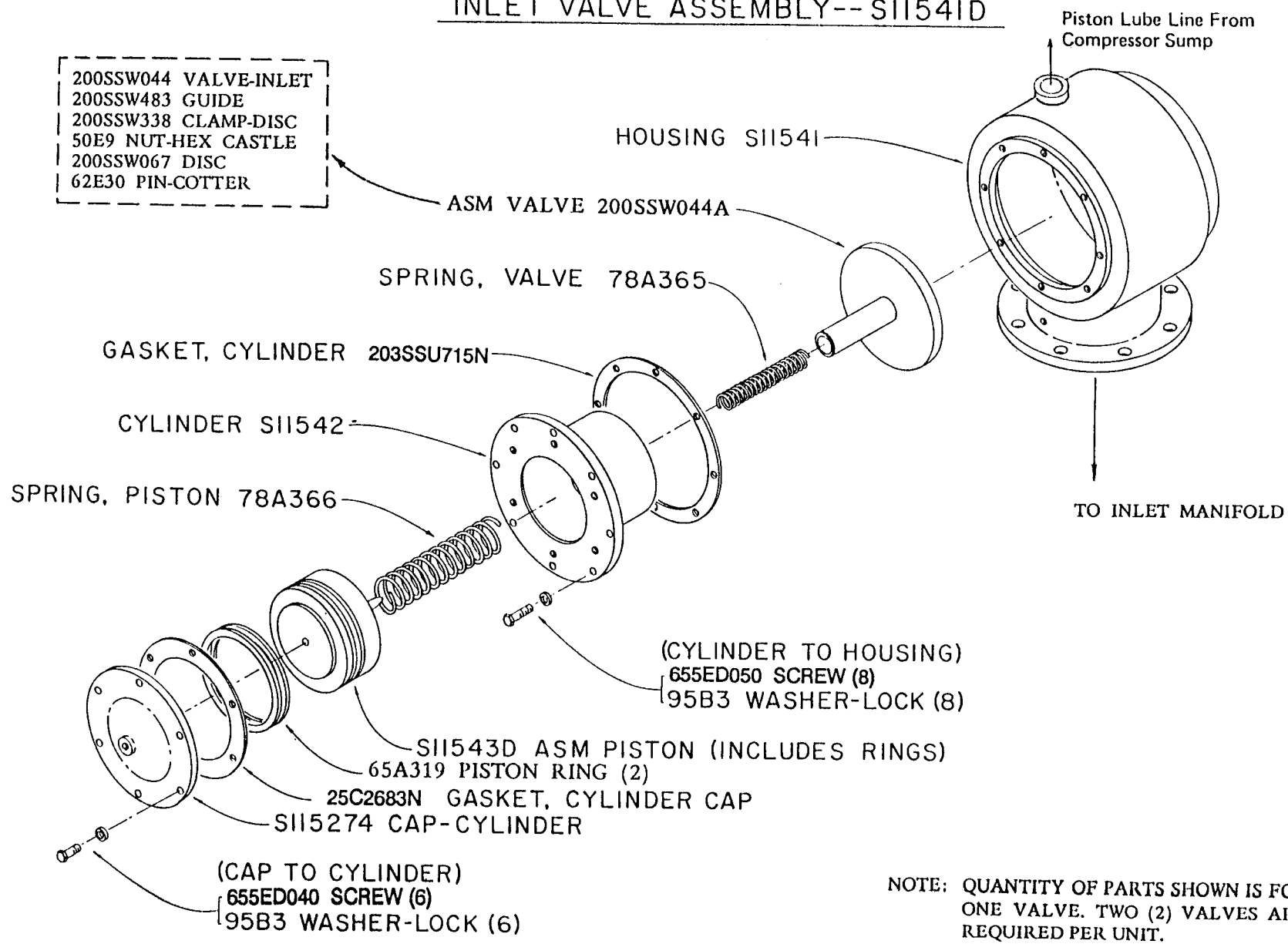

PURGE VALVE & MOUNTING GROUP

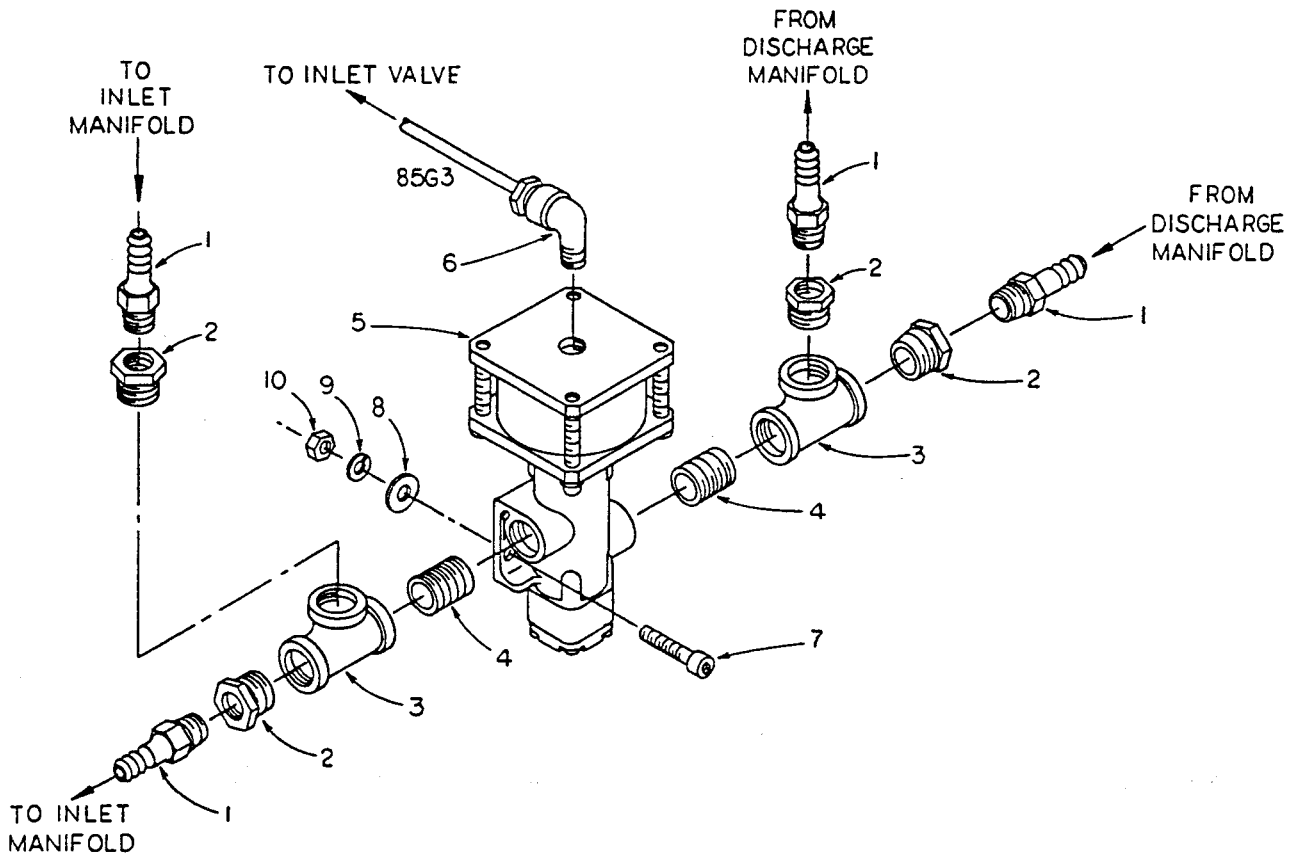

223EAY810

Order by part number and description. Reference numbers for your convenience only.

Ref. No.	Name of Part	Qty.	Part No.
1	NIPPLE-HOSE.....	4	29C26
2	BUSHING-PIPE.....	4	64E14
3	TEE-PIPE.....	2	64G8G
4	NIPPLE-PIPE.....	2	63H1G
5	VALVE-AIR CONTROL.....	1	90AR262
6	ELBOW-TUBE.....	1	86E60
7	SCREW-SoHd CAP.....	2	75P42
8	WASHER-PLAIN.....	2	95A2
9	WASHER-LOCK.....	2	95B2
10	NUT-HEX.....	2	50B2
+	CLAMP-HOSE.....	8	29B35
+	HOSE.....	4	R14*
+	REPAIR KIT (Gaskets, O-Rings & Springs).....	1	2109654

+ Not shown on illustration.

* Length to be specified when ordered.

OIL RESERVOIR GROUP

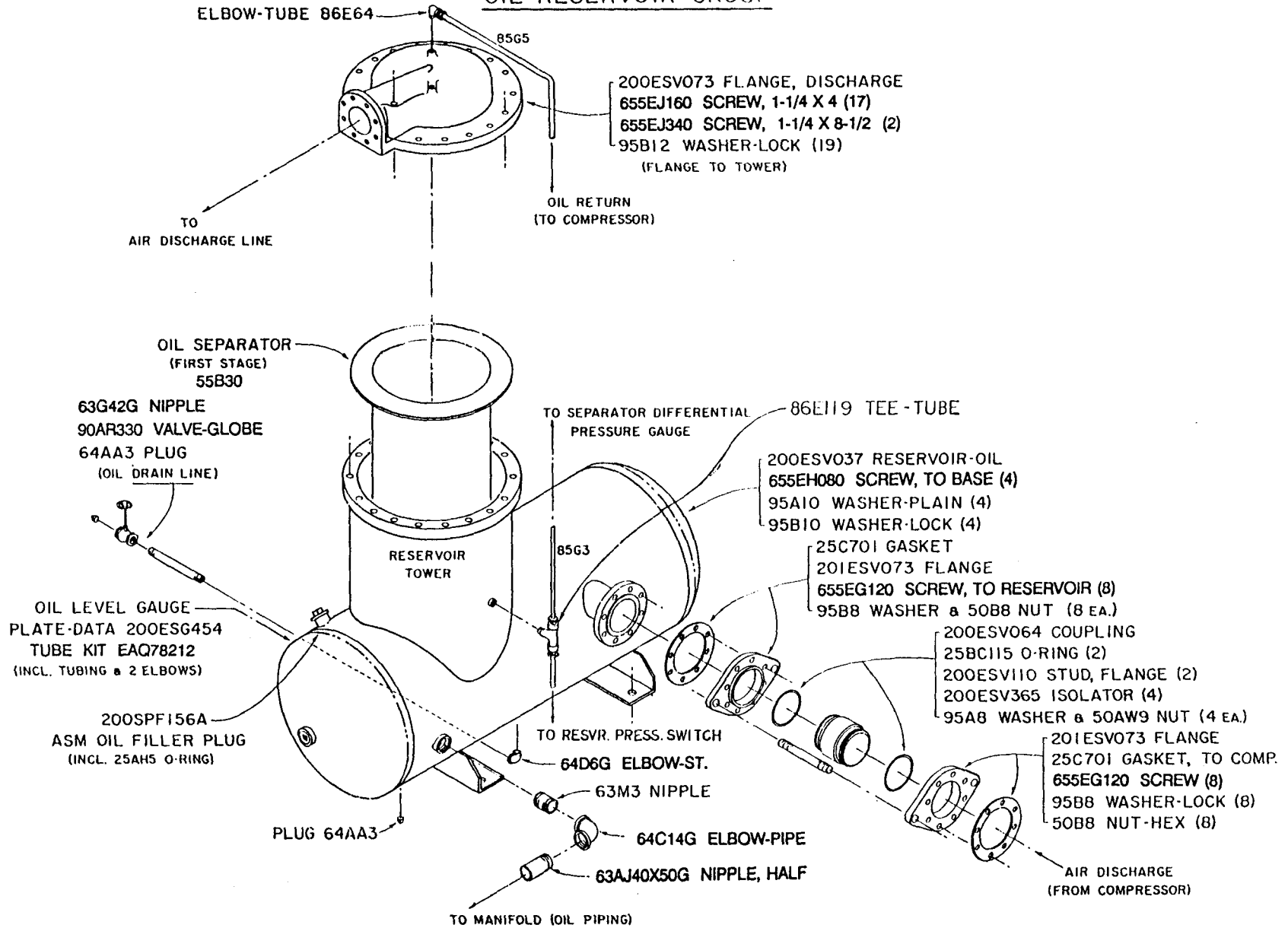

AIR DISCHARGE PIPING

(W/MANIFOLD TUBING)*

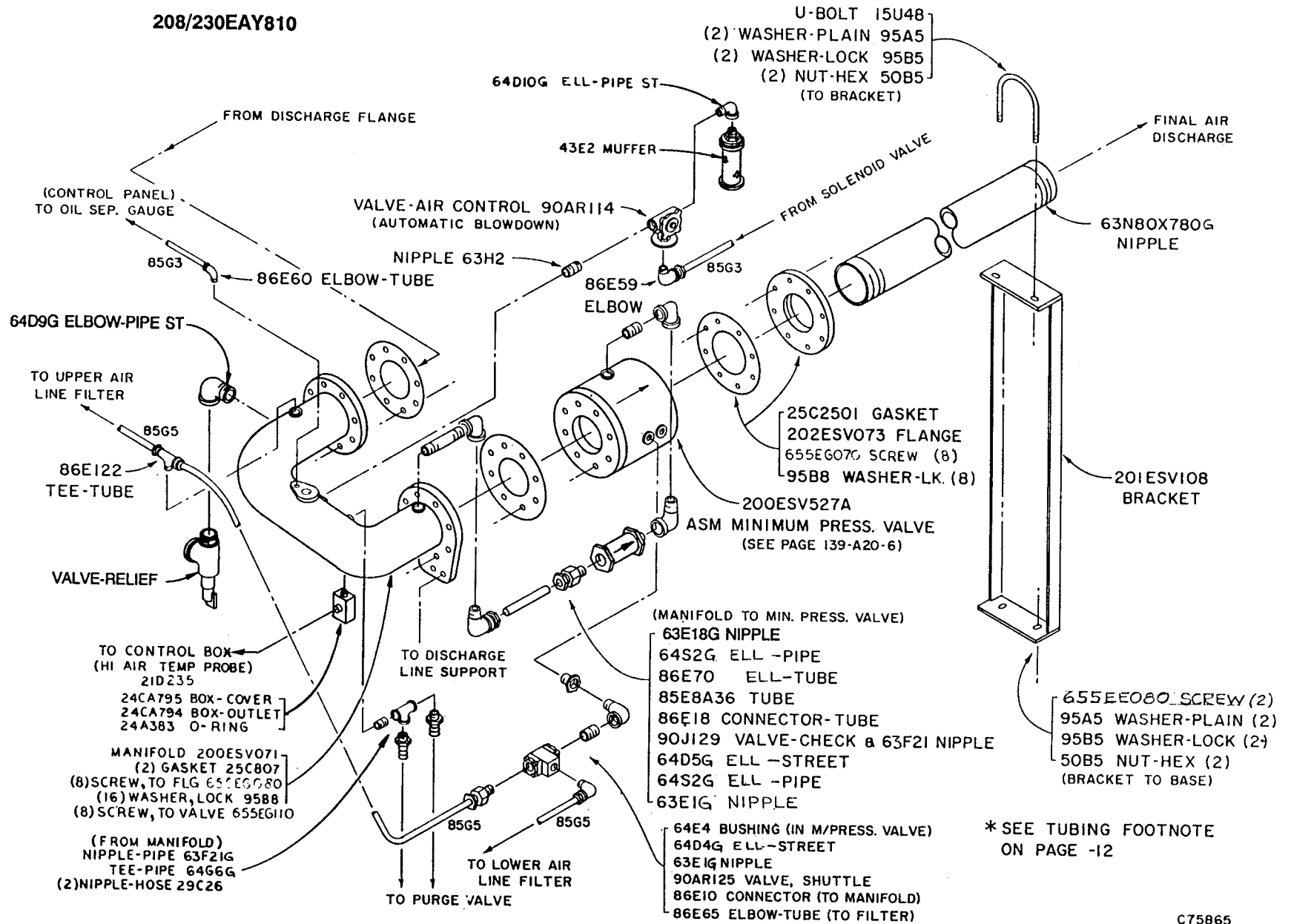

* SEE TUBING FOOTNOTE ON PAGE -12

OIL RESERVOIR GROUP
(Selective Items)

Name of Part	350, 400 & 500 HP
VALVE-RELIEF (Set 125 Lbs.).....	90AR110
VALVE-RELIEF (Set 150 Lbs.).....	90AR111
VALVE-RELIEF (Set 175 Lbs.).....	90AR264
REPAIR KIT, With Separator 55B30.....	EAY80129

NOTE: Repair Kit includes Separator, Discharge Flange Gasket and Internal Tubing as shown in illustration below.

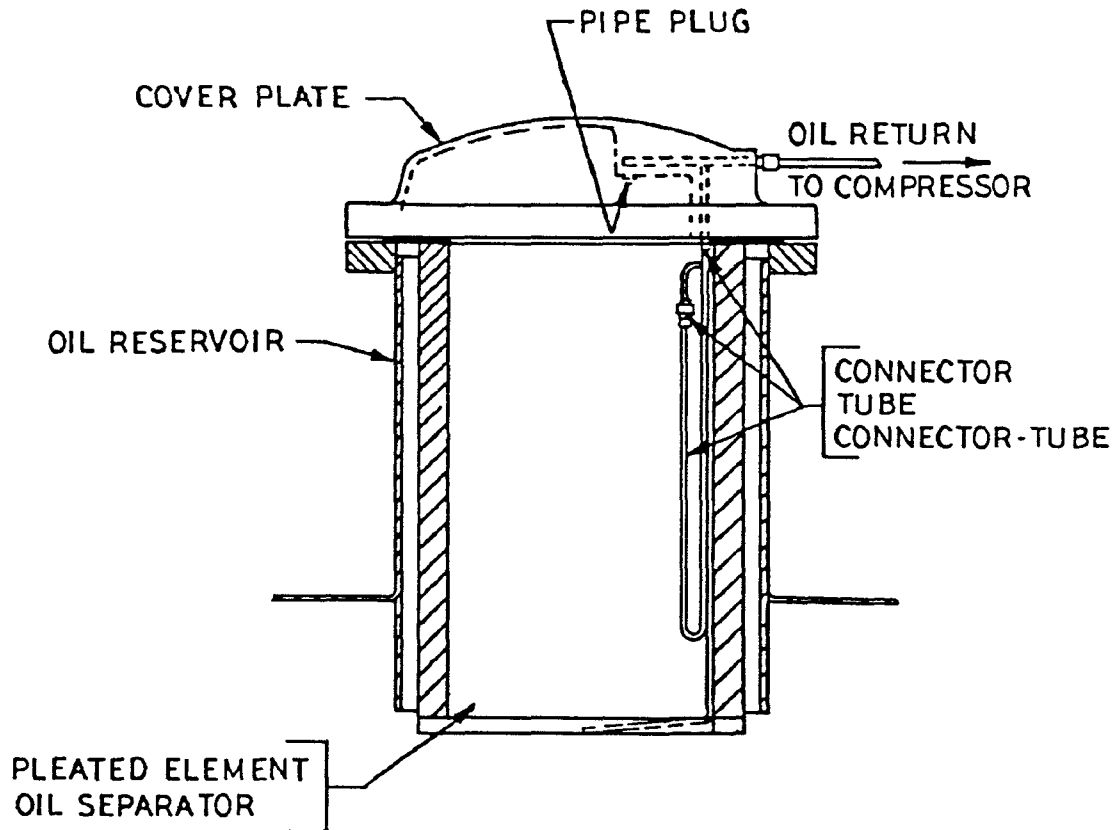

* Gaskets are bonded to separators but may be purchased separately for repair.

OIL PIPING GROUP
"C" Construction

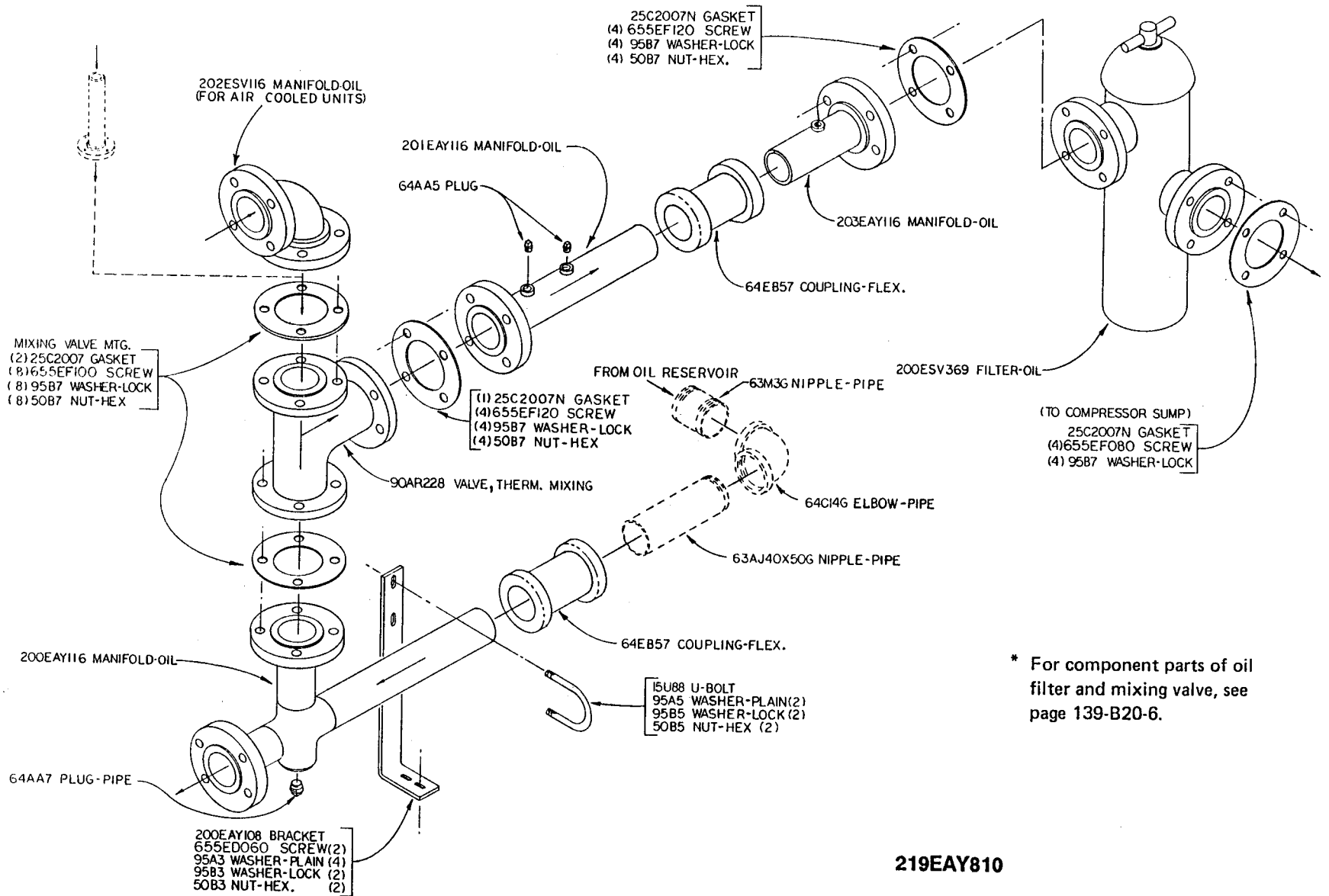

* For component parts of oil filter and mixing valve, see page 139-B20-6.

HEAT EXCHANGER GROUP – "C" Construction (Oil & Water Piping) (350 & 400 HP Units)

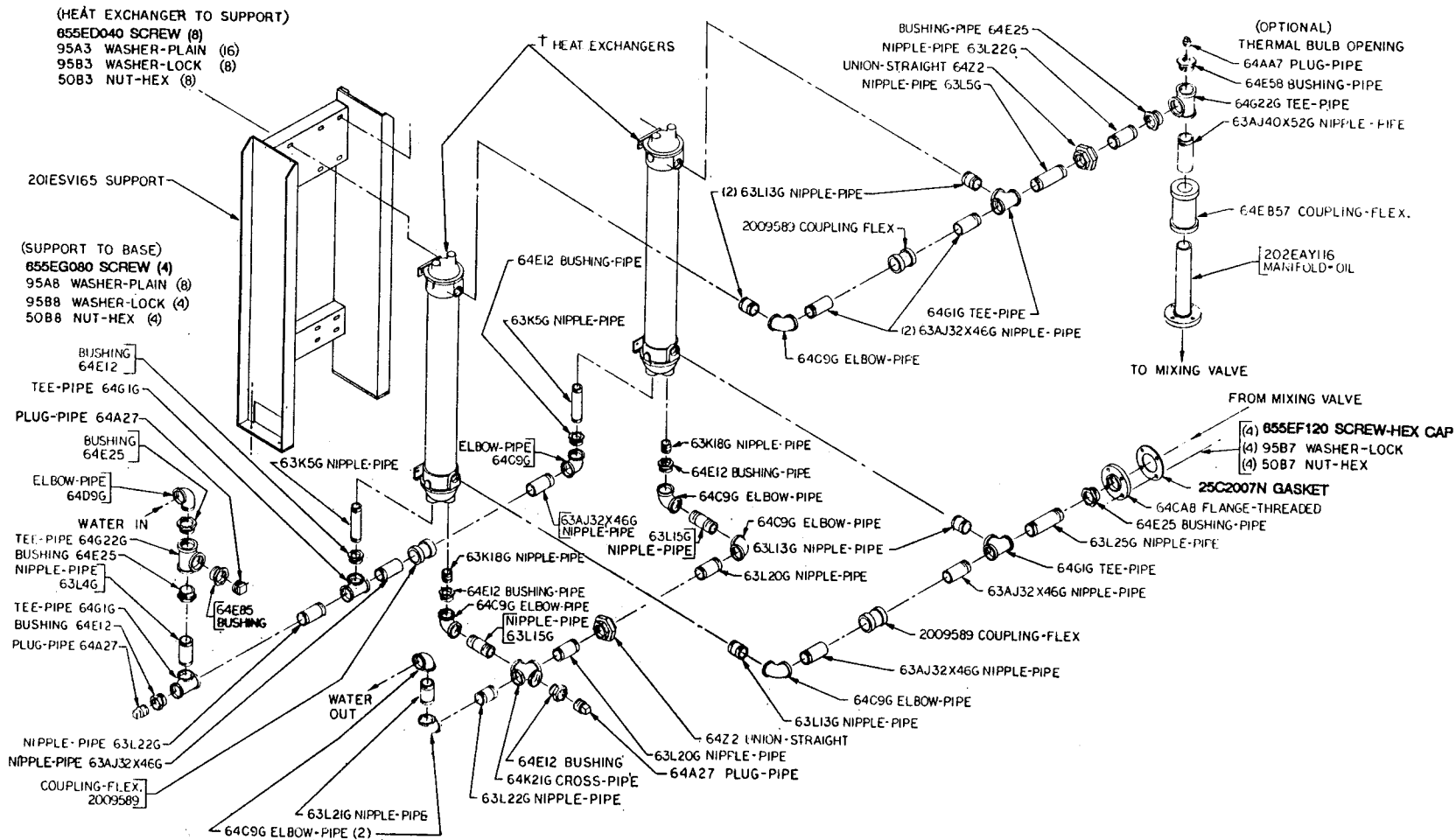

13-10-504 Page 17

218EAY810

† Selective – See page 139-A20-5a(W) or 139-A20-5b(W).

D76374

AFTERCOOLER & MOUNTING GROUP – “C” Construction (Optional Equipment)

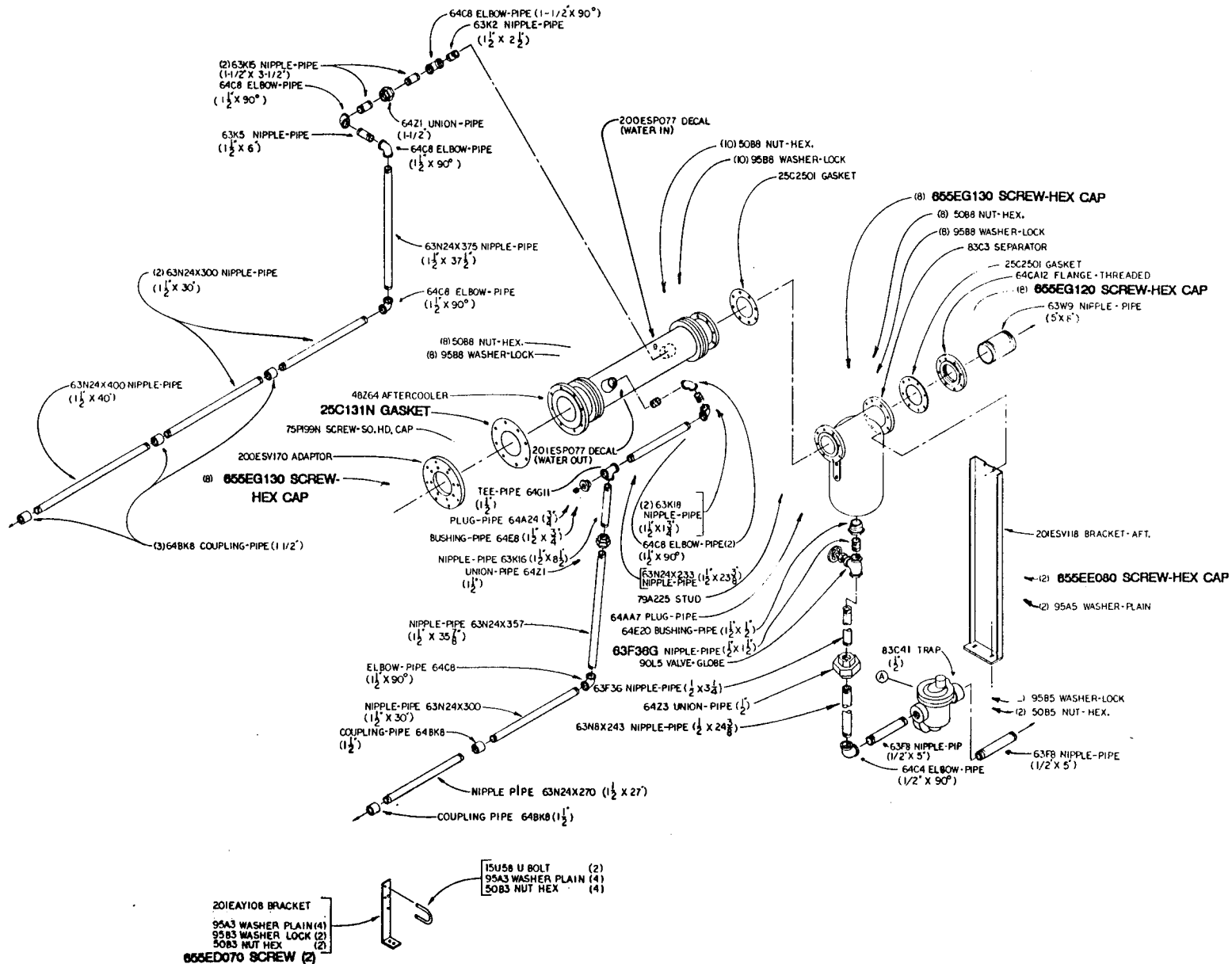

Note:

- (1) Fasteners (screws, nuts, etc.) are not shown. Refer to ordering instructions page.
- (2) No salt water aftercooler available.

**SELECTIVE ITEMS - WATER-COOLED UNITS
(Fresh Water Service)**

Name of Part	350 HORSEPOWER		400 HORSEPOWER		500 HORSEPOWER	
	VENDOR		VENDOR		VENDOR	
	Young	***Thermal Transfer	Young	***Thermal Transfer	***Thermal Transfer	American Standard
Heat Exchanger (2), Incl. next 5 parts	200ESS349	204ESS349	201SSP349	205ESP349	202ESV349	200ESV349
Bonnet, Inlet-Outlet (2)	2010280 *	2109065	2010280 *	2109065	2109065	2109120
Gasket, Inlet-Outlet (2)	2010252	2109063	2010252	2109063	2109063	2010294
Bonnet, Return (2)	2010281 *	2109066	2010281 *	2109066	2109061	2109119
Gasket, Return (2).....	2010204	2109064	2010204	2109064	2109064	2010295
Anode-Zinc (4)	2010284	2109068	2010284	2109068	2109057	2008266
Regulator-Temperature (Trefice).....	_____	_____	_____	_____	_____	_____
** Asm Stem Packing	_____	_____	_____	_____	_____	_____
** Thermal System Kit.....	_____	_____	_____	_____	_____	_____
Regulator-Temperature (Trefice).....	90AR152		90AR152		90AR152	
** Asm Stem Packing	2109051		2109051		2109051	
** Thermal System Kit.....	2109490		2109490		2109490	
Valve-Solenoid, Magnetic Water (Nema 1).....	91B2		91B2		91B2	
Valve-Solenoid, Magnetic Water (Nema 2).....	91B23		91B23		91B23	
	VENDOR		VENDOR		VENDOR	
	American Standard		American Standard		American Standard	
Aftercooler, Inc. next 3 parts	48Z64		48Z64		48Z64	
Gasket (2).....	2109145		2109145		2109145	
Ring-Packing (2)	2109146		2109146		2109146	
Ring-Lantern (Nylon)	2109147		2109147		2109147	
Separator, Moisture	83C10		83C10		83C10	
Trap, Separator, Incl. next 3 items	83C41		83C41		83C41	
Gasket, Cap	2109518		2109518		2109518	
Gasket, Retainer	2109519		2109519		210951	
Screen, Strainer	2109520		2109520		2109520	

- * When purchasing bonnet for "Young" Heat Exchanger, gasket and pipe plugs are included.
- ** Furnish as required for repair of complete temperature regulator (kit consists of remote bulb, capillary tube and bellows).
- *** Thermal Transfer used on current production units.

**SELECTIVE ITEMS - WATER-COOLED UNITS
(Salt Water Service)**

PART NAME & DESCRIPTION	350 HORSEPOWER		400 HORSEPOWER	
	VENDOR		VENDOR	
	Young	Thermal Transfer	Young	Thermal Transfer
Heat Exchanger, Incl. next 6 parts:	-----	203ESS349	-----	204ESP349
Bracket, Mounting (2)	-----	2109067	-----	2109067
Gasket, Inlet-Outlet	-----	2109063	-----	2109063
Bonnet, Inlet-Outlet	-----	2109077	-----	2109077
Gasket, Return	-----	2109064	-----	2109064
Bonnet, Return	-----	2109076	-----	2109076
Anode-Zinc (2)	-----	2109068	-----	2109068
Regulator-Temperature (Trexice)	-----	-----	-----	-----
** Asm Stem Packing	-----	-----	-----	-----
** Thermal System Kit	-----	-----	-----	-----
Regulator-Temperature (Trexice)	-----	90AR106	-----	90AR106
** Asm Stem Packing	-----	2109051	-----	2109051
** Thermal System Kit	-----	2109490	-----	2109490

** Furnish as required for repair of complete temperature regulator (kit consists of remote bulb, capillary tube and bellows).

OIL FILTER, MINIMUM PRESSURE & MIXING VALVES

(COMPONENT PARTS)

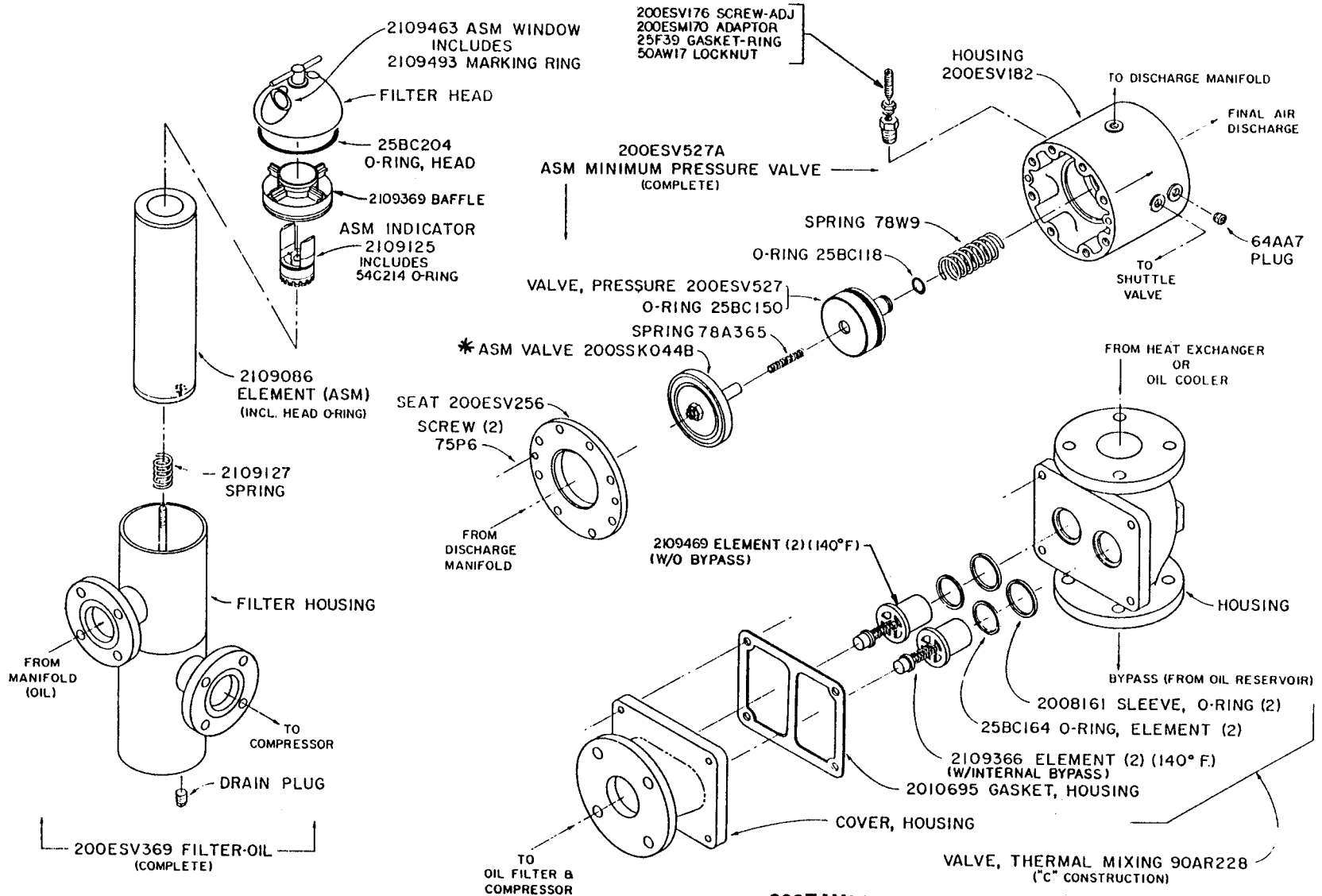

208EAY810

D75869

* BUNA N DISC # 200SSK067
 VITON DISC # 201SSK067

COUPLING & MISC. TUBE FITTINGS

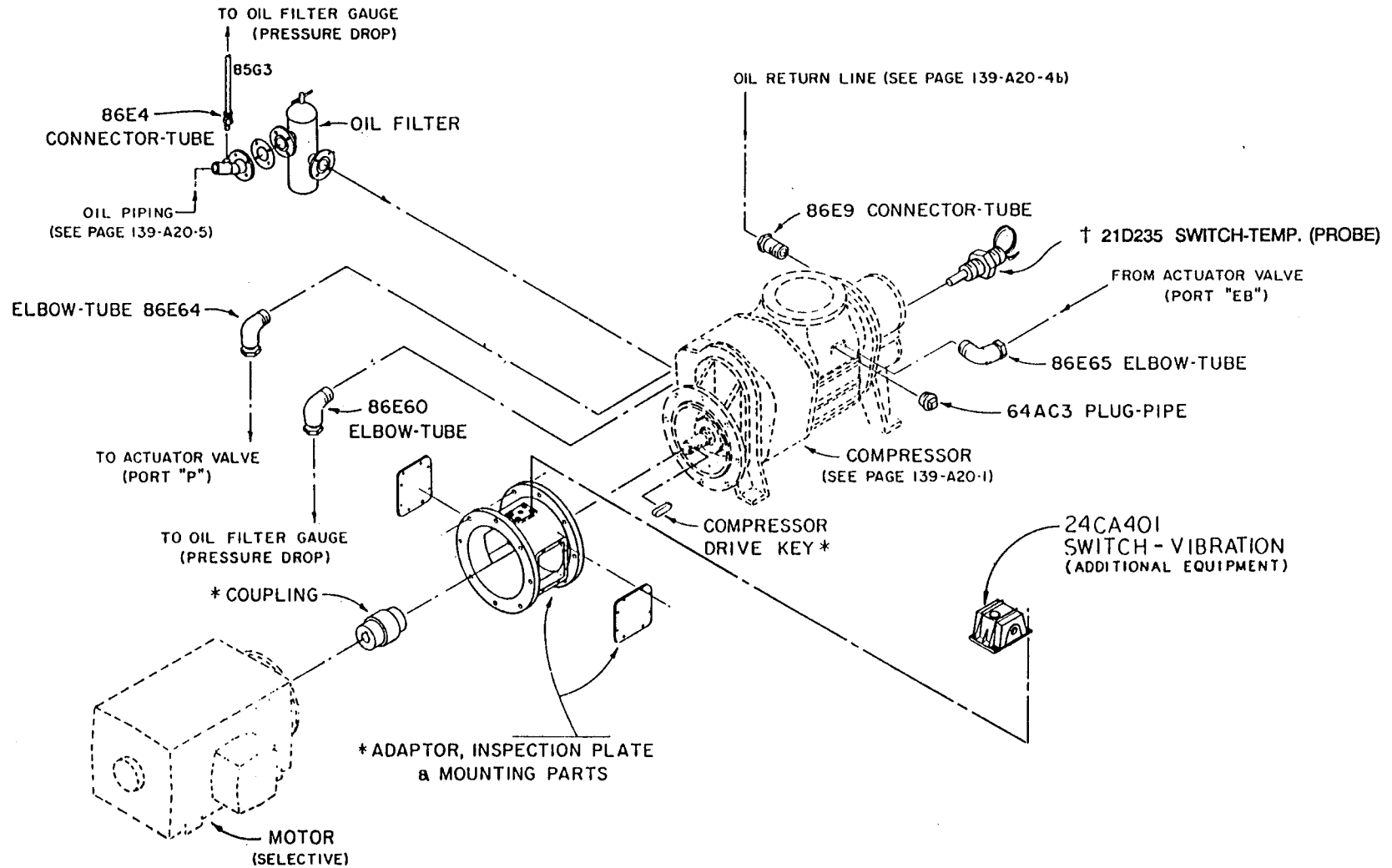

† PRIOR TO SERIAL NUMBER 777754, TEMP SWITCH 24CA779 & TEMP PROBE 24CA780 WERE USED, FOR REPAIR ORDER KIT NUMBER EAQ76381.

* SEE PAGE 139-A20-7A FOR PART NUMBERS, COUPLING IS SELECTIVE.

COUPLING & MOTOR MOUNTING
(Selective)

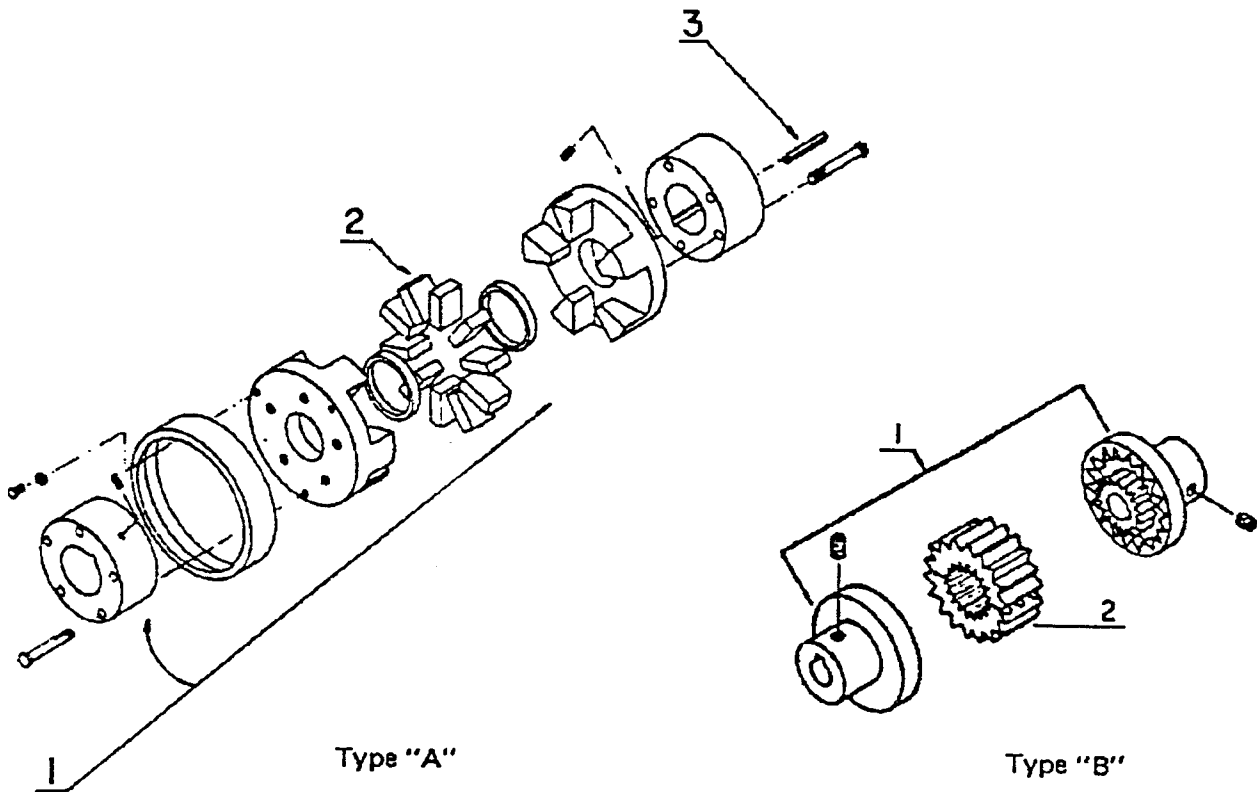

Order by part number and description. Reference numbers for your convenience only.

Ref. No.	Name of Part	Qty.	350, 400 HP 460, 2300 & 4600 Volt	500 HP 460 Volt	500 HP 2300 & 4000 Volt
COUPLING GROUP					
1	COUPLING (With Set Screws & Cushions)...	1	2011977	2011977	51134
2	CUSHION (Type "A")	10	2109118	2109118	2109118
2	COUPLING, With Split Sleeve (Type "B")	1	2109609	2109609	2109609
3	KEY, Compressor Drive (3/4 x 3/4 x 3.50).....	1	35L28	35L28	35L28
+	ADAPTOR, Compressor to Motor.....	1	200SSW170	200SSW170	200SSQ170
+	PLATE, Inspection.....	2	201SSW247	201SSW247	201SSW247
+	SCREW, To Adaptor.....	16	75LM51	75LM51	75LM51
+	SCREW, To Motor & Compressor	16	75A214	75A214	75A214
+	WASHER-LOCK (3/4)	16	95B8	95B8	95B8
+	NUT-HEX (3/4).....	16	50B8	50B8	50B8
MOTOR MOUNTING					
+	SPACER (2")	4	200ESV144	200ESV144	None
+	SCREW, Isolator to Base (Thru Spacer)	4	75AA28	75AA28	75AA28
+	WASHER-PLAIN (3/4).....	8	95A8	95A8	95A8
+	WASHER-LOCK (3/4)	4	95B8	95B8	95B8
+	NUT-HEX (3/4).....	4	50B8	50B8	50B8

+ Not shown on illustration.

NOTE: Motor is selective - refer to Sales Office.

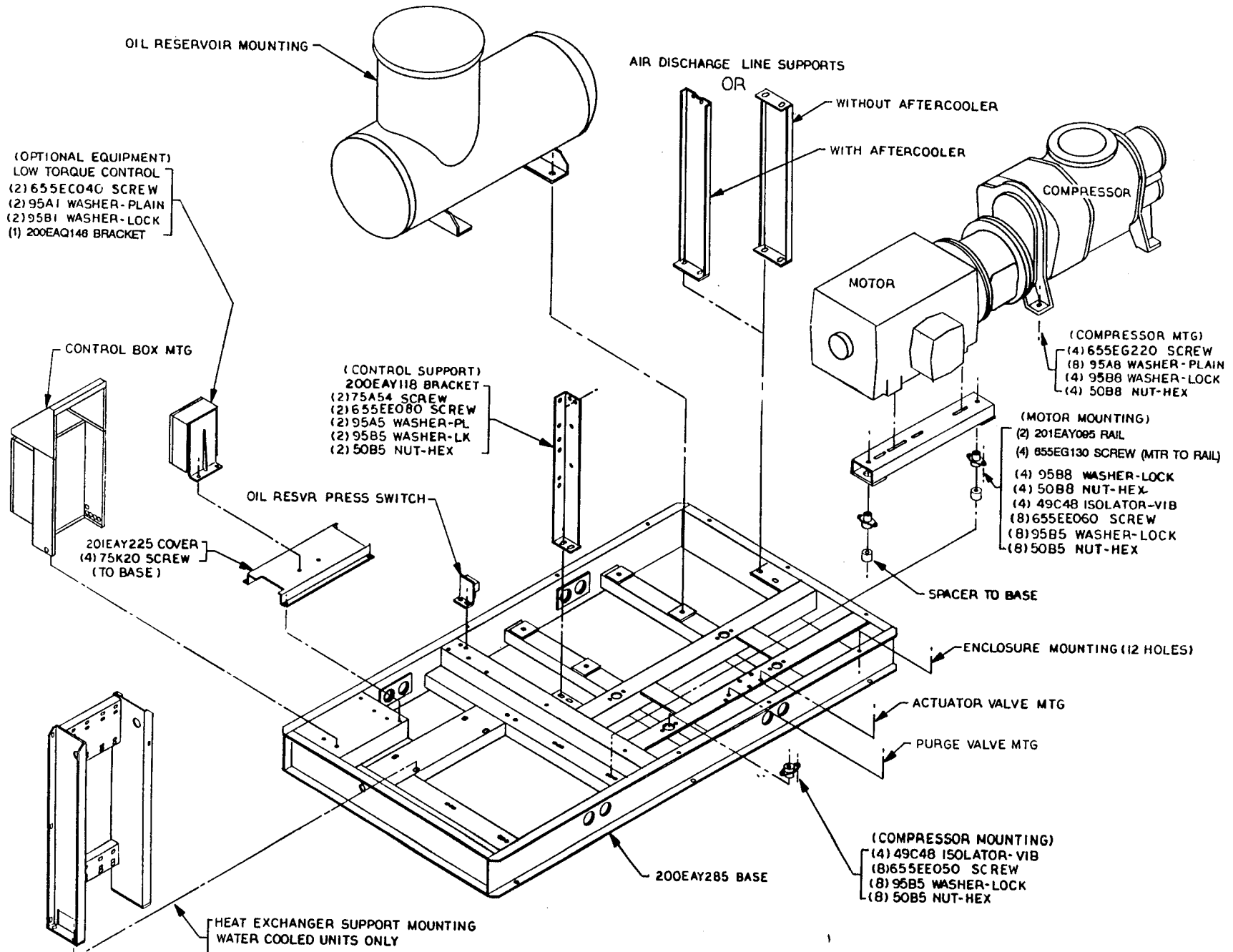

OIL COOLER GROUP

PART NAME & DESCRIPTION	350/400 HP	500 HP
WITHOUT AFTERCOOLER		
ASSY. MODULE (COMPLETE)	201EAY204	203EAY204
ASSY. OIL COOLER	2116205	2116207
FAN 2116209	2116209	2116210
FAN GUARD.....	2116211	2116212
WITH AFTERCOOLER		
ASSY. MODULE (COMPLETE)	202EAY204	204EAY204
ASSY. OIL COOLER	2116205	2116207
ASSY. AFTERCOOLER.....	2116206	2116208
FAN	2116209	2116210
FAN GUARD.....	2116211	2116212

NOTE:

Assy. module part numbers shown are for units furnished with 230/460 volt van motor mounted by vendor.

CONTROL COMPONENTS & TUBING *

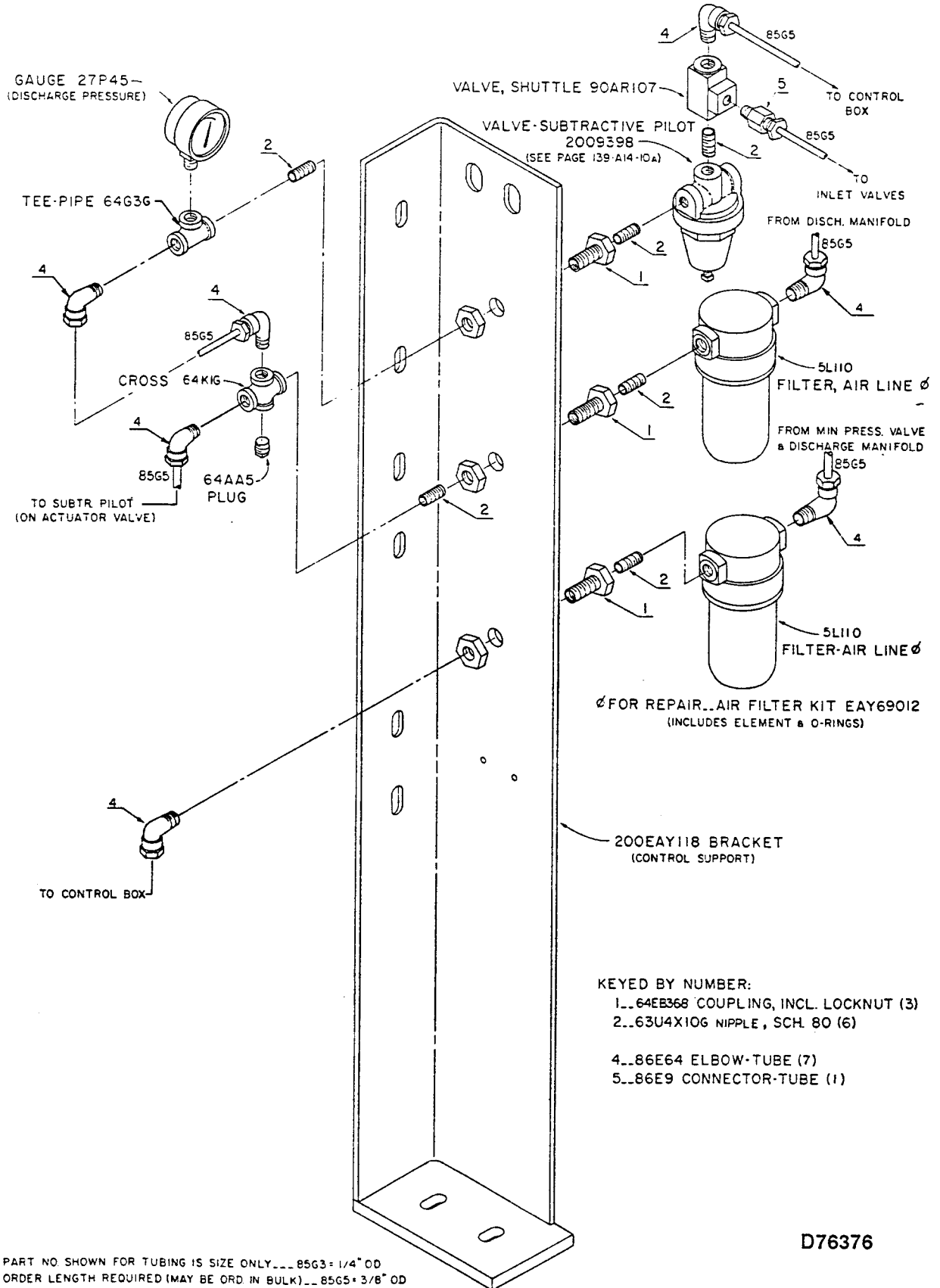

D76376

SUBTRACTIVE PILOT VALVE - 2009398
(SEE NOTE)

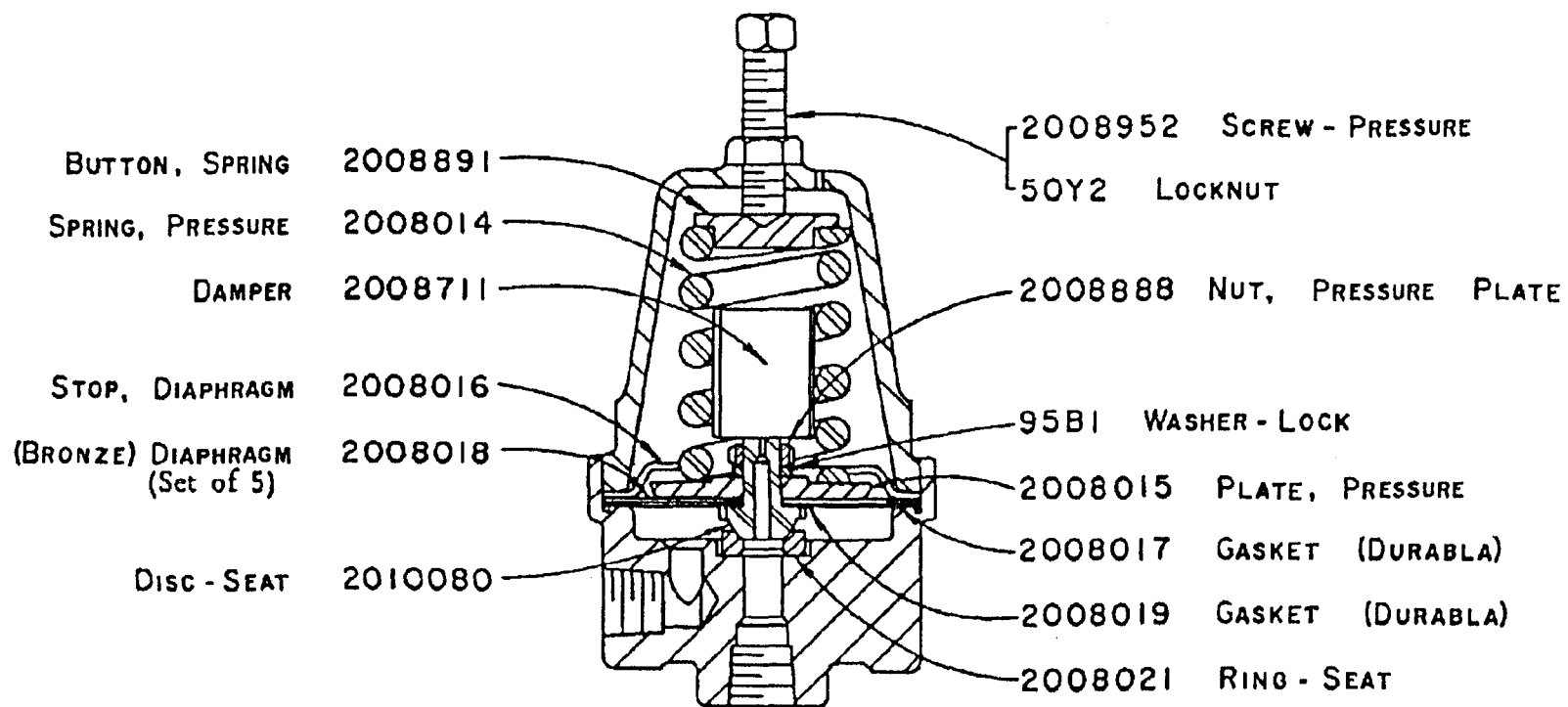

B74408X

NOTE: It is necessary to replace some parts in groups to insure satisfactory repair. When replacing diaphragm also replace both diaphragm and seat gaskets. When replacing seat disc or seat ring replace also the mating seat ring or disc and the seat disc gasket.

OIL RESERVOIR PRESSURE SWITCH

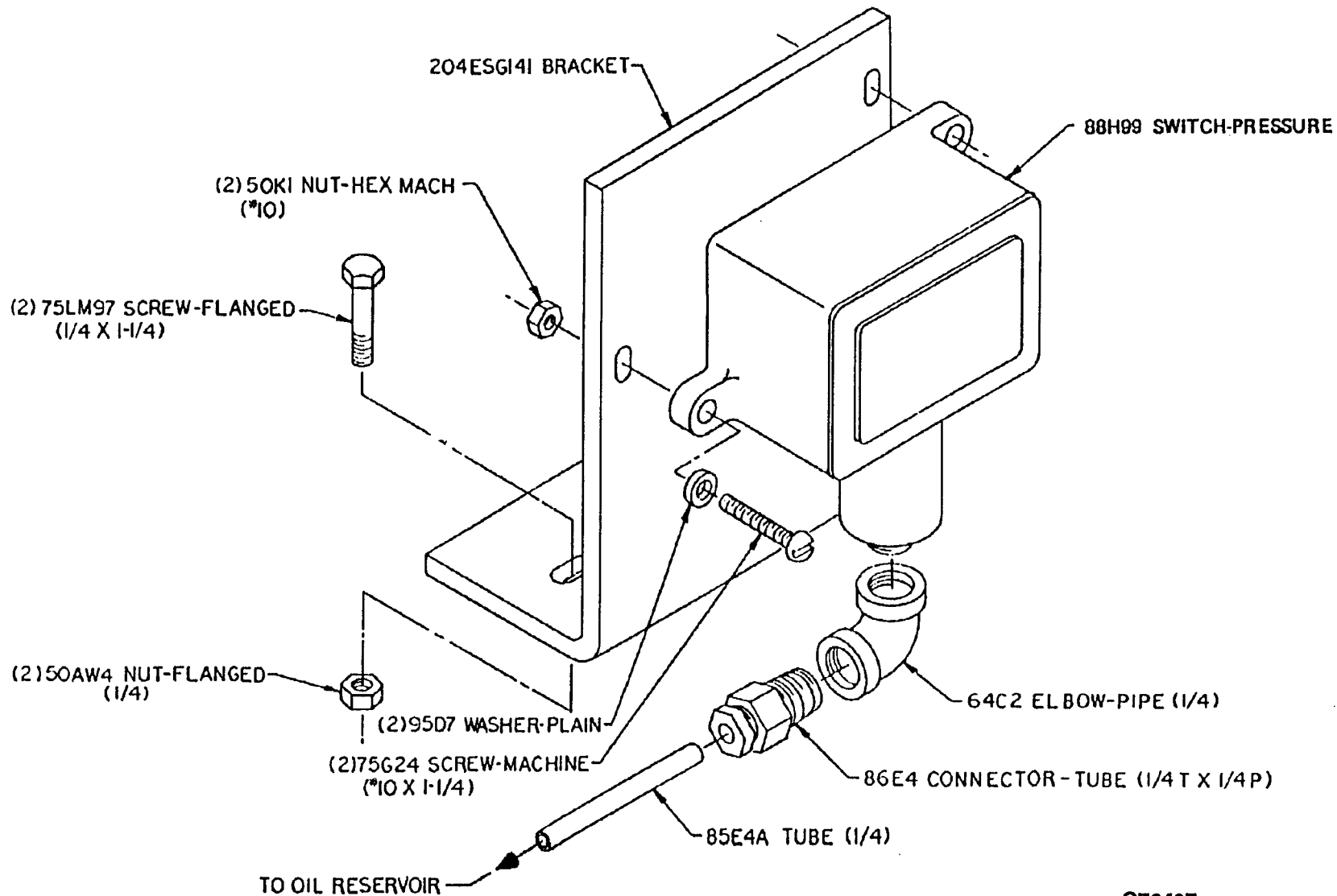

*** CONTROL PANELS ("C" CONSTRUCTION)
(Gauge Panel)**

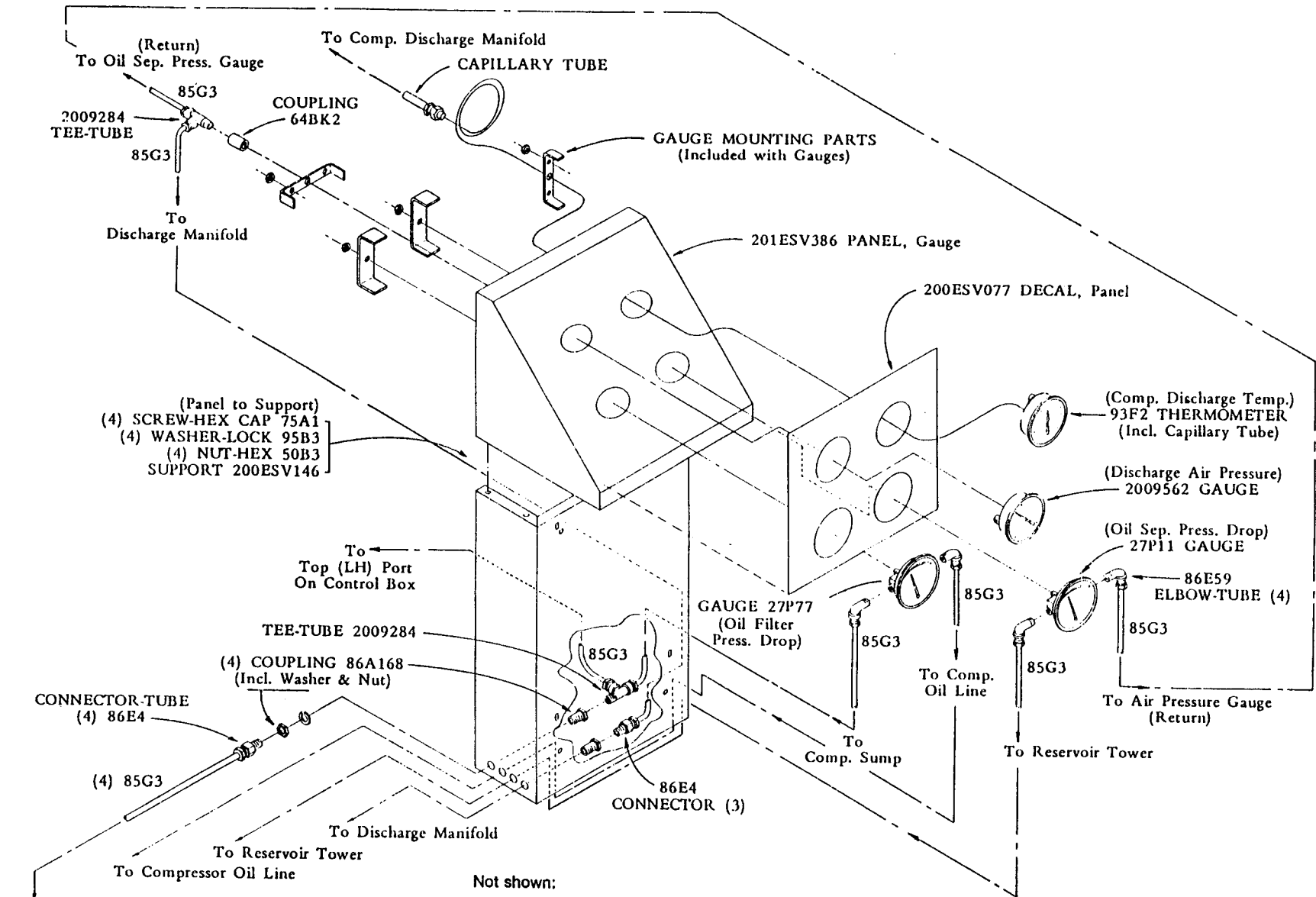

- (Panel to Support)
 (4) SCREW-HEX CAP 75A1
 (4) WASHER-LOCK 95B3
 (4) NUT-HEX 50B3
 SUPPORT 200ESV146

- Not shown:
 201EAY225 COVER, Tube
 75LM97 SCREW, To Base (4)
 50AW4 NUT, To Base (4)

200ESV810

D76377

CONTROL PANELS ("C" CONSTRUCTION)
 (Electrical Panel)
 (Effective With S/N 77754)

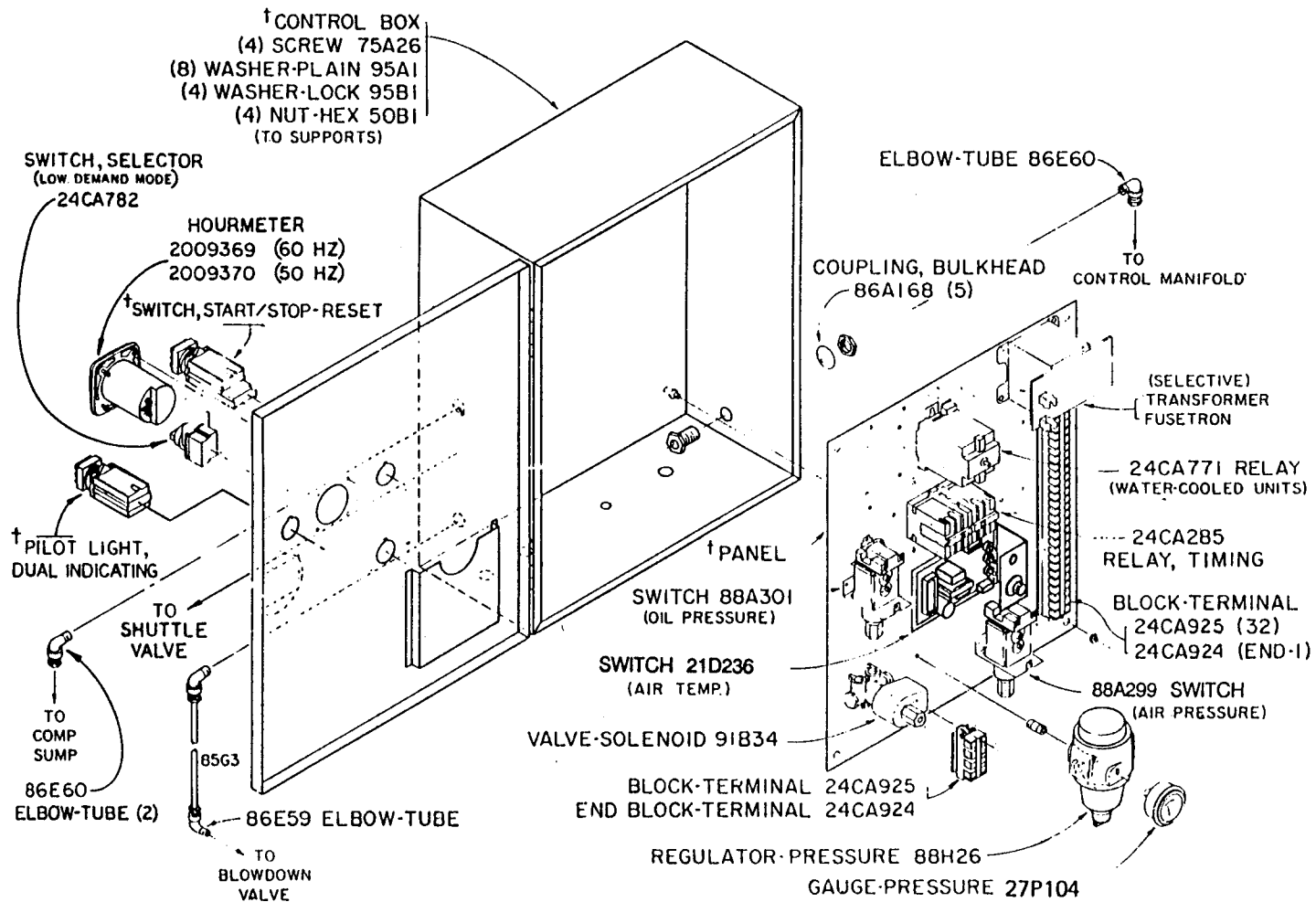

† Selective items - see page 139-C20-11a.

CONTROL ITEMS ("C" CONSTRUCTION)
(Selective)

Part Name & Description	Constant Speed		Automatic Start-Timed Stop	
	Nema 1	Nema 4	Nema 1	Nema 4
BOX-CONTROL.....	200ESO179	201ESO179	203EAQ170	204EAQ179
PANEL, Electrical.....	207ESO216	208ESO216	207ESO216	208SEO216
BOOT, Transparent (PB).....	----	24CA281	----	24CA281
O-RING, Bulkhead (4).....	----	24A383	----	24A383
GASKET, Hourmeter.....	----	201ESK715	----	201ESK715
SEAL-PLUG (2).....	----	24A509	----	24A509
SWITCH, Start/Stop-Reset (Momentary)*	24CA1793	24CA1793	----	----
SWITCH, On/Off/Reset (Maintained)**	----	----	24CA1817	24CA1817
LAMP, Indicator.....	24CA40	24CA40	24CA40	24CA40
PILOT LIGHT, Dual Indicating.....	24CA552	24CA552	24CA552	24CA552
BOX-CONTROL, Timer.....	----	----	----	200ESK179
GASKET, Control Box.....	----	----	----	202ESK715
COVER, Timer.....	----	----	----	202ESK225
GASKET, Timer Cover.....	----	----	----	203ESK715
TIMER.....	----	----	24A482	24A482
RELAY.....	24CA541	24CA541	24CA541	24CA541

+ Low Torque Control

ASSEMBLY (Complete).....	202EAQ564
(Major Components)	
VALVE, Air Control.....	90AR127
VALVE, Flow Control.....	90J110
VALVE, Shuttle.....	90AR107

* Units equipped with Manual Starter use Stop-Reset Switch 24CA1478 with 24CA217 and 24CA1297 Contact Blocks.

** 24CA1817 Switch is "Maintained" ON, and "Momentary" RESET.

+ Used only when specified on Order Ticket (Optional Equipment). May be used with either Nema 1 or Nema 4 Controls.

TUBING SCHEMATIC – "C" Construction

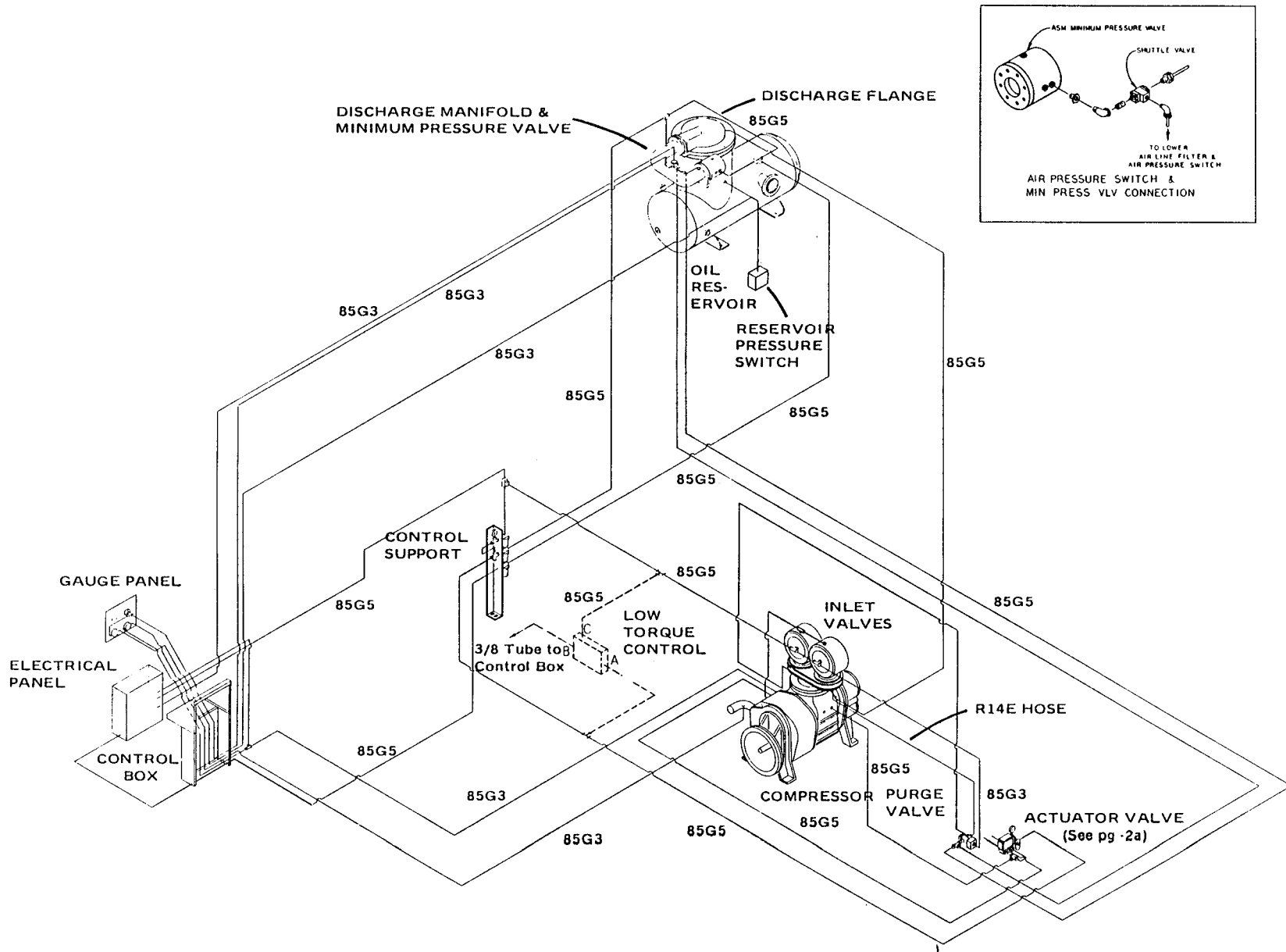

13-10-504 Page 33

Note: Part number shown for tubing are for size only — 85G3 = 1/4" O.D.
 Order length required (may be ordered in bulk). 85G5 = 3/8" O.D.

201EAY810

E76378

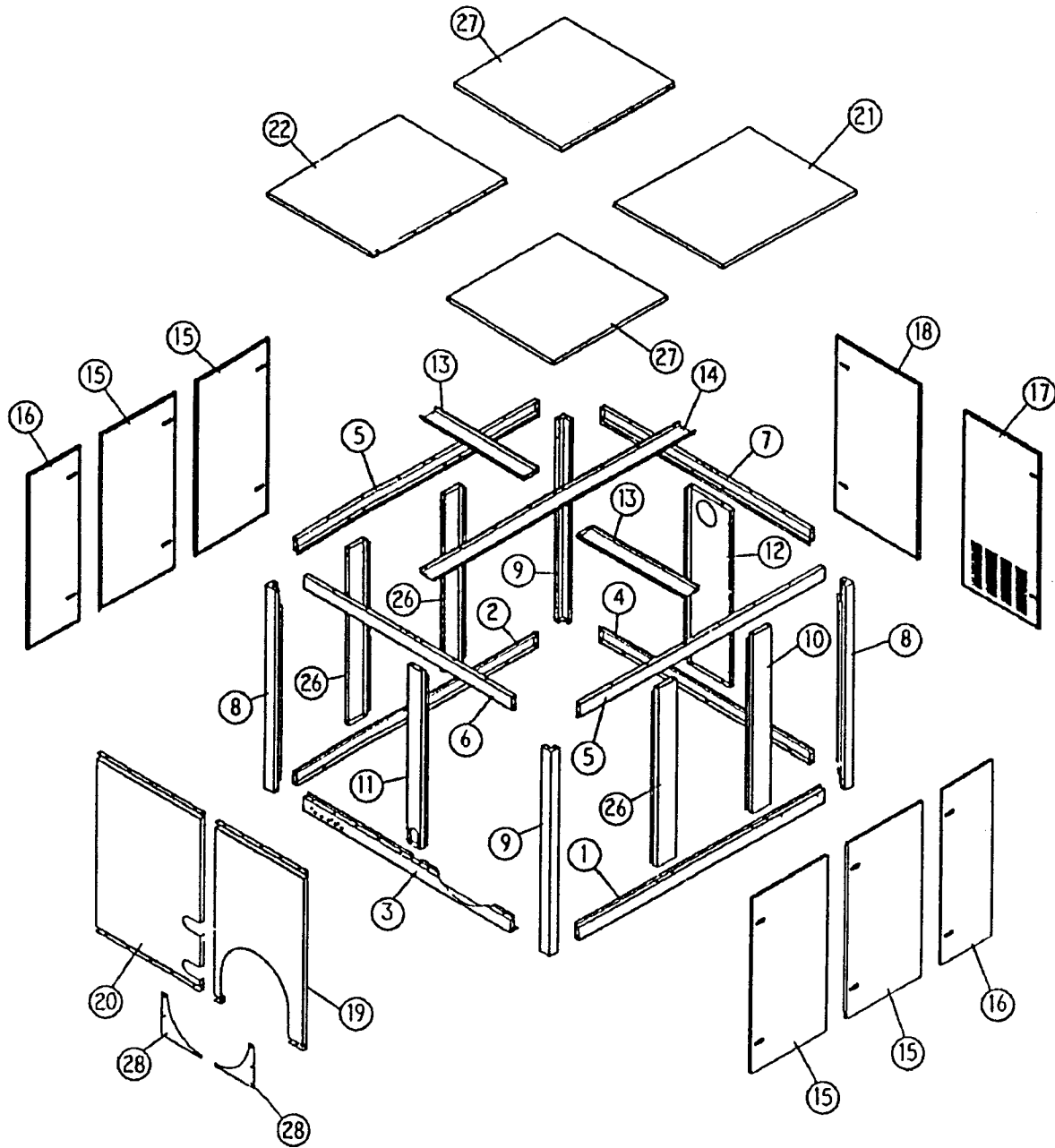

231EAY810

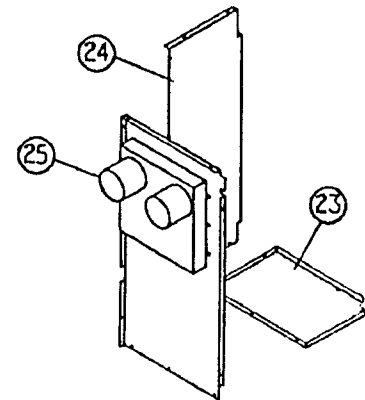

Det. No.	Name	Qty	Part Number
1	FRAME.....	1	200EAY314
2	FRAME.....	1	200EAY314
3	FRAME.....	1	202EAY314
4	FRAME.....	1	203EAY314
5	FRAME.....	1	204EAY314
6	FRAME.....	1	205EAY314
7	FRAME.....	1	206EAY314
8	POST.....	2	201EAY313
9	POST.....	2	202EAY313
10	BRACE.....	1	200EAY326
11	BRACE.....	1	201EAY326
12	BRACE.....	1	202EAY326
13	BRACE.....	2	203EAY326
14	BRACE.....	1	204EAY326
15	DOOR.....	4	200EAY334
16	DOOR.....	2	201EAY334
17	DOOR.....	1	202EAY334

Det. No.	Name	Qty	Part Number
17	DOOR.....	1	202EAY334
18	DOOR.....	1	203EAY334
19	PANEL.....	1	202EAY216
20	PANEL.....	1	203EAY216
21	PANEL.....	1	204EAY216
22	PANEL.....	1	205EAY216
23	PANEL.....	1	206EAY216
24	PANEL.....	1	207EAY216
25	DUCT.....	1	200EAY856
26	BRACE.....	3	205EAY326
27	PANEL.....	2	212EAY216
28	PANEL.....	2	200EAY216
*	SCREW.....	133	75LM51
*	NUT.....	145	50AW5
*	LATCH.....	16	31D51

* Not shown.

REPAIR KITS

1)	ROUTINE MAINTENANCE KIT (3000 HOURS)		EAY68417
	(2) FILTER-AIR	2009590	
	(3) FILTER-OIL	26A43	
	(3) ELEMENT, OIL FILTER	2109086	
	(1) O-RING, OIL FILTER	25BC140	
	(1) INDICATOR - ASM.	2109125	
2)	PERIODIC MAINTENANCE		EAY68806
	(2) ELEMENT, MIX. VLV.	2109366	
	(2) O-RING, ELEMENT	25BC164	
	(1) GASKET, HOUSING	2010695	
	(2) DISCHARGE, INLET VLV.	200SSW067	
	(1) SPRING, INLET VALVE	78A365	
	(1) SPRING, VALVE PISTON	78A366	
	(2) RING-PISTON	65A319	
	(1) VALVE DISC.	201SSK067	
3)	PERIODIC OVERHAUL KIT (SSYAAA)		EAY68419
	(1) GASKET KIT	EAY68420	
	(2) BEARING, TURN VALVE	12BA53	
	(1) BEARING, INLET	12BA61	
	(1) BEARING, INLET	12BA47	
	(2) BEARING, DRIVE SHAFT	12BA37	
	(1) BEARING, DISCHARGE	12BA39	
	(1) BEARING, DISCHARGE	12BA38	
	(1) BEARING, DISCHARGE	12BA40	
	(1) BEARING, DISCHARGE	12BA37	
	(1) SEAL-SHAFT	60DD602	
	(9) SCREW-HEX CAP	75A18N	
	(9) SCREW-HEX CAP	75A74N	
	(8) SCREW-HEX CAP	75A75N	
3)	PERIODIC OVERHAUL KIT (SSYAAB)		SSY77311
	(1) BEARING, ROLLER	12BA107	
	(1) BEARING, ROLLER	12BA109	
	(1) BEARING, ROLLER	12BA47	
	(1) BEARING, ROLLER	12BA108	
	(2) BEARING, ROLLER	12BA37	
	(2) BEARING, ROLLER	12BA53	
	(3) SCREW, HEX HD	655EF08N	
	(4) SCREW, HEX HD	655ED04N	
	(3) SCREW, HEX CAP	655EG09N	
	(3) SCREW, HEX HD	655EF08N	
	(2) SCREW, HEX CAP	75A68N	
	(1) KEY, SQUARE	35L14	
	(1) KEY, SQUARE	35L20	

REPAIR KITS (CONTINUED)

3)	PERIODIC OVERHAUL KIT (CONTINUED)		SSY77311
	(1) KEY, SQUARE	35C114	
	(1) SEAL, OIL	60DD602	
	(2) GASKET, RING	25BC15N	
	(2) "O" RING	25BC115	
	(1) FILTER, OIL	26A43	
	(1) ELEMENT, FILTER	2109086	
	(1) "O" RING	25BC140	
	(1) KIT, GASKET	SSY77310	
4)	SEPARATOR KIT		EAY80129
	(1) SEPARATOR, OIL	55B30	
	(3) TUBE (3 Ft.)	85G3	
	(1) PLUG, PIPE	64AA6	
	(1) UNION, TUBE	86E48	
	(1) CONNECTOR, TUBE	86E4	
	(1) GASKET	25C807N	
5)	PNEUMATIC CONTROL & GAUGE KIT		EAY73994
	(1) REGULATOR-PRESS.	88H26	
	(1) GAUGE-AIR PRESSURE	2009562	
	(1) THERMOMETER	93F2	
	(1) GAUGE-PRESS.	27P45	
	(2) AIR FILTER	2109620	
	(1) VALVE, SHUTTLE	90AR107	
	(1) VALVE, PURGE	90AR262	
	(1) VALVE, BLOWDOWN	90AR114	
	(1) VALVE, TURN	90AR427	
	(2) VALVE-SUB PILOT	2009398	
	(2) "O" RING	2116000	
6)	ELECTRICAL CONTROL KIT		EAQ73988
	(1) SWITCH-PRESSURE	88A299	
	(1) RELAY	24CA285	
	(1) SWITCH, PRESSURE	88A301	
	(1) VALVE, SOLENOID	91B34	
	(1) SWITCH, TEMP.	21D234	
	(1) SWITCH, PRESSURE	88H99	
	(2) PROBE, TEMP.	21D235	
7)	DRIVE COUPLING KIT		EAU77786
	(6) CUSHION, COUPLING	2109118	
7)	DRIVE COUPLING KIT		EAY77785
	(1) ELEMENT, COUPLING	2109609	

Gardner --- **Denver**

For additional information, contact Gardner Denver Machinery Inc.,
1800 Gardner Expressway, Quincy, Illinois 62301
Telephone (217) 224-8800 • Fax (217) 224-7814

Specifications subject to change without notice.

COPYRIGHT 1994 Gardner Denver Machinery Inc.

Litho in USA