

# **BroomWade Cyclon 105-222 REPAIR MANUAL**

**C20160-1538F**

Serial Nos from:

F160-0101

F161-0201

F162-0301

F163-0401

F164-0501

F165-0601

**1 of 2    December 95**



# **BroomWade Cyclon 105-222 REPAIR MANUAL**

**C20160-1538F**

Serial Nos from:

F160-0101

F161-0201

F162-0301

F163-0401

F164-0501

F165-0601

2 of 2 December 95



# **CYCLON SERIES**

## **BroomWade**

### **AIR COMPRESSORS**

### **REPAIR MANUAL**

Serial Numbers from:

Cyclon 105 F160/0101

Cyclon 107 F161/0201

Cyclon 111 F162/0301

Cyclon 215 F163/0401

Cyclon 218 F164/0501

Cyclon 222 F165/0601

## FOREWORD

1. Worldwide service and parts facilities are provided by CompAir BroomWade Distributors. The service and parts departments at High Wycombe are available should any difficulty be experienced.
2. It is essential to quote the compressor MODEL and SERIAL numbers in all communications.
3. All pressures shown are gauge pressures.
4. The substitution of parts not manufactured or approved by CompAir BroomWade can reduce performance or service life and create potential mechanical or personnel hazards.
5. The right is reserved to modify the contents of this publication without notice and the data given is in no way binding on the manufacturers.
6. Where approximate figures are shown, specific details are available on request.

## WARRANTY

The conditions of the CompAir BroomWade Warranty are set out in the company's standard Conditions of Sale available from the Distributor supplying the machine.



## WARNING



- The use of replacement parts or lubricating oils not supplied or approved by CompAir BroomWade may lead to failures in service which would not be covered by warranty.
- Any unauthorised modifications or failure to maintain this equipment in accordance with the maintenance instructions may make it unsafe. The use of replacement parts not supplied or approved by CompAir BroomWade may create hazardous conditions over which CompAir BroomWade has no control.
- Such hazardous conditions may lead to accidents that can be life threatening, cause substantial bodily injury or result in damage to the equipment. CompAir BroomWade can bear no responsibility for equipment in which unapproved replacement parts are included.

**USE ONLY**

 **CompAir**

**GENUINE PARTS  
AUTHORISED SERVICE AGENTS**

---

## CONTENTS

Chapter	Title
1	Safety Procedures
2	General Description
3	Leading Particulars, Installation and Commissioning
4	Operation and Fault Finding
5	Components
6	Maintenance
7	Electrical System
8	Disassembly and Assembly

## ILLUSTRATIONS

### Chapter 2

No.	Title	Page
2.1	General Arrangement	1
2.2	Air-End - General Arrangement	3
2.3	Control Panel	5
2.4	Air/Oil System	7
2.5	Regulation System (Schematic)	9

### Chapter 4

4.1	Control Panel	3
4.2	Remote Start/Stop	8
4.3	Remote Load/Unload	8
4.4	Group Fault Relay – Example	9

### Chapter 5

5.1	Air-End - General Arrangement	1
5.2	Separator Element	2
5.3	Suction Regulator	3
5.4	Manifold Block	5
5.5	Minimum Pressure Valve – Models 105, 107	6
5.6	Minimum Pressure Valve – Models 215, 218	7
5.7	Oil Cooler	9
5.8	Aftercooler	10
5.9	Thermostatic Bypass Valve	11
5.10	Scavenge Solenoid Valve And Timer Modul	12
5.11	Unloader Solenoid Valve	13
5.12	Pressure Transmitter	14
5.13	Temperature Sensor	15

### Chapter 6

6.1	Servicing Points	4
6.2	Drive Belt Adjustment	8

---

**Chapter 7**

<b>No.</b>	<b>Title</b>	<b>Page</b>
7.1	Control Panel	1
7.2	Controller (Rear Connections)	2
7.3	Starter Assembly	2
7.4	Auxiliary Contact	3
7.5	Remote Start/Stop	5
7.6	Remote Load/Unload	5
7.7	Group Fault Relay – Example	6
7.8	Cable Connection or Removal	8
7.9	Controller Relay Contact Outputs	13
7.10	Measuring The Transmitter Current	14

**Chapter 8**

8.1	Scavenge Coupling Tool	10
8.2	Air-End Oil Seal Removal Plate	15
8.3	Air-End Oil Seal Installation Sleeve	16
8.4	Drive Belt Adjustment	18

**Associated Publications**

Title	Part Number
Parts Lists (Multi-Lingual)	C20160-1537

---

# CHAPTER

# 1

## SAFETY PROCEDURES

<b>Description</b>	<b>Page</b>
General	1
Warnings, Cautions and Notes	1
General Safety Precautions	2
Installation Precautions	2
Operational Precautions	2
Maintenance and Repair Precautions	3
Precautions in the Event of Fire	4

---

## SAFETY PROCEDURES

### 1. GENERAL

Most accidents which occur during the operation and maintenance of machinery are the result of failure to observe basic safety rules or precautions. An accident can often be avoided by recognising a situation that is potentially hazardous.

When handling, operating or carrying out maintenance on the unit, personnel must use safe engineering practices and observe all relevant local health and safety requirements and regulations. The attention of users in the UK is drawn to the Health and Safety at Work Act, 1974, the Regulations of the Institution of Electrical Engineers and the Pressure Systems and Transportable Gas Container Regulations 1989.

CompAir BroomWade cannot anticipate every possible circumstance which might represent a potential hazard. The **WARNINGS** in this manual are therefore not all-inclusive. If the user employs an operating procedure, an item of equipment or a method of working which is not specifically recommended by CompAir BroomWade he must ensure that the unit will not be damaged or made unsafe and that there is no risk to persons or property.

Failure to observe the precautions given under 'Safety Procedures' may be considered dangerous practice or misuse of the compressor unit.

### 2. WARNINGS, CAUTIONS AND NOTES

#### 2.1 Warnings

Warnings call attention to operations or procedures involving specific hazards which could cause injury or death and are identified by the following symbols on the unit and in the text of the manual.



**WARNING: RISK OF DANGER**



**WARNING: RISK OF ELECTRIC SHOCK**



**WARNING: RISK OF HOT SURFACES**



**WARNING: CONSULT MANUAL**



**WARNING: RISK OF HIGH PRESSURE**

#### 2.2 Cautions

Incorrect operational procedures causing possible damage to the compressor unit are identified by a '**CAUTION**' in the text of this manual.

#### 2.3 Notes

Methods to make the job easier and points which require particular attention are identified by a '**Note**' in the text of the manual

### 3. GENERAL SAFETY PRECAUTIONS

If using compressed air for cleaning purposes, ensure safety regulations are complied with and appropriate clothing and eye protection is worn.

Never direct compressed air onto your skin or at other people.

Never use compressed air to clean loose dirt from clothing.

Before releasing compressed air through a hose make sure that the free end is held securely so that it cannot whip and cause injury.

Avoid injury by using a hoist to lift heavy loads. Check that all chains, hooks, shackles and slings are in good condition and are of the correct capacity. They must be tested and approved according to local safety regulations.

Cables, chains or ropes must never be applied directly to lifting eyes. Always use an appropriate shackle or hook, properly positioned. Arrange lifting cables so that there are no sharp bends.

Use a spreader bar to avoid side loads on hooks, eyes and shackles.

When a load is on a hoist stay clear of the danger area beneath and around it. Keep lifting acceleration and speed within safe limits and never leave a load hanging on a hoist for longer than is necessary.

### 4. INSTALLATION PRECAUTIONS

Installation work must only be carried out by competent personnel under a qualified supervisor.

A fused isolating switch must be fitted between the main power supply and the compressor.

Ensure that air drawn into the air intake will not be contaminated with flammable fumes or vapours, since this could cause an internal fire or explosion.

Precautions must be taken to ensure that no injury is caused to passers-by through loose clothing being sucked into the air intake.

Ensure that the air delivery pipe from the compressor to the user's pipework or receiver is free to expand and that no flammable material is within the vicinity.

A shut-off valve must be fitted in the delivery air line to enable the compressor unit to be isolated. This is particularly important if more than one unit is to be coupled in parallel or connected to an existing air supply system.

The minimum pressure/non-return valve is not intended as an isolating valve and should not be relied upon for this purpose. In addition, it may be necessary to install shut-off valves elsewhere in the system to allow a dryer or other equipment to be by-passed.

A pressure relief valve must be installed between any compressor unit and the shut-off valve/s. A pressure relief valve is fitted on the reclaimer vessel as standard equipment.

A pressure relieving device must be fitted to every pressure vessel, or equipment containing air at above atmospheric pressure, when installed downstream of the unit.

In order to control the risk of Legionnaires Disease, CompAir BroomWade strongly advise against the use of water cooling tower systems for water cooled compressors. A closed circuit radiator system is preferred (see Bulletin CBB 2083).

### 5. OPERATIONAL PRECAUTIONS

The compressor unit must only be operated by competent personnel under a qualified supervisor.

Do not run the compressor with doors open or covers removed.

Never remove or tamper with the safety devices, guards or insulation materials fitted to the unit.

The compressor must only be operated at the supply voltage and/or frequency for which it is designed.

When mains power is switched on, lethal voltages are present in the electrical circuits and extreme caution must be exercised whenever it is necessary to carry out any work on the electrical system.

Do not open the starter compartment or touch electrical components while voltage is applied unless it is necessary for measurements, tests or adjustments. Such work should be carried out only by a qualified electrician equipped with the proper tools and wearing appropriate body protection against electrical hazards.

On a unit equipped with an Automatic Start/Stop system, attach a sign stating **'THIS UNIT MAY START WITHOUT WARNING'** next to the display panel.

On a unit equipped with an Automatic Restart device, attach a warning notice stating **'THIS UNIT HAS BEEN MODIFIED AND WILL START AUTOMATICALLY ON APPLICATION OF POWER'** next to the display panel and on the inside of the unit next to the starter contactors.

If the unit is equipped with a Remote Control device, attach warning notices stating **'THIS UNIT CAN BE STARTED REMOTELY'** in prominent locations, one on the outside of the unit, the other inside the control compartment.

As a further safeguard, take adequate precautions to make sure there is no one checking or working on the unit before attempting to switch on remotely controlled equipment. Attach a **'CHECK THAT ALL PERSONNEL ARE CLEAR OF THE UNIT BEFORE STARTING'** or similar warning notice to the remote start equipment.

During normal operation no internal part of the compressor unit should reach a temperature above 100°C and protection devices are fitted to prevent excessive temperatures occurring. On water cooled models, the cooling water outlet pipe is likely to reach 80°C and must be painted or marked according to the local safety code. The pipe must be guarded or insulated where injury to personnel could occur.

If there is any indication that the compressor is overheating it must be shut down and the cause investigated. Beware of burns from hot metal parts, hot oil and water when working on a unit which has recently been shut down.

The compressor must not be operated at pressures above the nominal pressure given on the data plate.

The compressor must not be operated in ambient temperatures outside of those given under 'Leading Particulars'.

The 'Noise at Work Regulations 1989' suggest that ear protectors should be worn where noise levels are 85 dB(A) or higher. With all covers in place, the noise levels of the compressors described in the manual are substantially lower than this figure unless installed in an already noisy environment.

Be aware that high noise levels can interfere with communication.

## 6. MAINTENANCE AND REPAIR PRECAUTIONS

Maintenance, repairs or modifications must only be carried out by competent personnel under a qualified supervisor.

If replacement parts are needed use only CompAir BroomWade Genuine Parts.

Before removing any panels from the enclosure, if fitted, or dismantling any part of the unit, carry out the following preparatory operations:-

1. Isolate the compressor unit from the main electrical power supply. Lock the isolator in the 'OFF' position and remove the fuses.
2. Attach a label to the isolator switch and display panel carrying the warning **'WORK IN PROGRESS – DO NOT APPLY VOLTAGE'** Do not switch on electrical power or attempt to start the unit if a warning label is attached.
3. Close the isolating valve between the compressor unit and the user's pipework. Close the isolating valve in the cooling water inlet pipe. Attach a label to each valve carrying the warning **'WORK IN PROGRESS – DO NOT OPEN'**
4. **Ensure that the blowdown system has operated to release all pressure from the reclaimers.**
5. Check that the pressure gauge registers zero. Release any remaining pressure from the delivery side of the reclaimers element by slackening the pipe connection to the

differential pressure switch at the reclaimer end. Release any residual pressure from the upstream side of the reclaimer element by slowly slackening the oil filler plug on the reclaimer. Tighten the plug.

Use only lubricating oils and greases approved by CompAir BroomWade. Make sure that the selected lubricants comply with all relevant safety regulations, especially with regard to the risk of explosion or fire and the possibility of decomposition or the generation of hazardous gases.

Always clean up oil spills from the surrounding floor and outside of the compressor unit before and after maintenance work.

Make sure that all instructions concerning operation and maintenance are strictly followed and that the complete unit, with all accessories and safety devices, is kept in good running order.

The accuracy of pressure and temperature gauges and switching thermometers must be regularly checked. They must be renewed when acceptable tolerances are exceeded.

Protection devices must be tested as described in the 'Maintenance' section of this manual.

Keep the compressor unit clean at all times. Protect components and exposed openings by covering with clean cloth or tape during maintenance and repair work.

Protect the motor, air intake, electrical and regulation components against the entry of moisture, e.g. when steam cleaning.

Precautions must be taken when carrying out welding or any repair operation which generates heat, flames or sparks. The adjacent components must always be screened with non-flammable material and if the operation is to be carried out near any part of the oil system, or close to a component which may contain oil, the system must first be thoroughly purged, preferably by steam cleaning.

Never use a light source with an open flame to inspect any part of the unit.

In no circumstances must any welding work or other modification be carried out on the reclaimer or any other pressure vessel.

Before dismantling of any part of the compressor unit ensure that all heavy movable parts are secured.

After completion of repair or maintenance work ensure that no tools, loose items or rags are left on or inside any part of the machine.

Check the direction of rotation of the motor when starting up the compressor initially and after any work on the electrical connections or switchgear.

**Do not** use any flammable liquid to clean valves, filter elements, cooler air passages, air pipes or any component carrying a flow of air during normal operation. If chlorinated hydrocarbon non-flammable fluids are used for cleaning, safety precautions must be taken against any toxic vapours which may be released.

**Do not use carbon tetrachloride.**

Precautions must be taken when using acids, alkalis and chemical detergents for cleaning machine parts and components. These materials cause irritation and are corrosive to the skin, eyes, nose and throat. Avoid splashes and wear suitable protective clothing and goggles. Do not breathe mists. Ensure that water and soap are readily available.

When disposing of condensate, old oil, used filter elements and other parts and waste material of any kind make sure that there is no pollution of any drain or natural water-course and that no burning of waste takes place which could cause pollution of the air. Protect the environment by using only approved methods of disposal.

## **7. PRECAUTIONS IN THE EVENT OF FIRE**

**Use extreme caution when handling components that have been subjected to fire or very high temperatures.** Some components may contain fluoroelastomer materials which decompose under these conditions to form highly corrosive residues. Skin contact can cause painful and penetrating burns resulting in permanent skin and tissue damage.

---

# CHAPTER

# 2

## GENERAL DESCRIPTION

<b>Description</b>	<b>Page</b>
Compressor	1
Air-End (Cyclon 1 or 2)	2
Description	2
Operation	2
Electronic Controller	4
Protection and Safety Equipment	4
Relief Valve	4
Blowdown System	4
Minimum Pressure/Non-return Valve	4
Air/Oil System	6
Description	6
Operation	6
Regulation System	8
Description	8
Operation	8

---

## GENERAL DESCRIPTION

### 1. COMPRESSOR

The unit is a fully enclosed, air cooled, single-stage, rotary screw compressor. The compressor air-end is belt driven by an electric squirrel-cage induction motor. The drive belt(s) are mounted on pulleys fitted to the shafts of the drive motor and air-end.

The compressor unit consists of the drive motor, air-end, oil separator vessel, oil separator filter, oil cooler, aftercooler, cooling fan, starter assembly and controller.

The complete compressor unit is mounted on a baseframe and is housed in a steel panelled acoustic enclosure. A service panel allows access for routine maintenance.

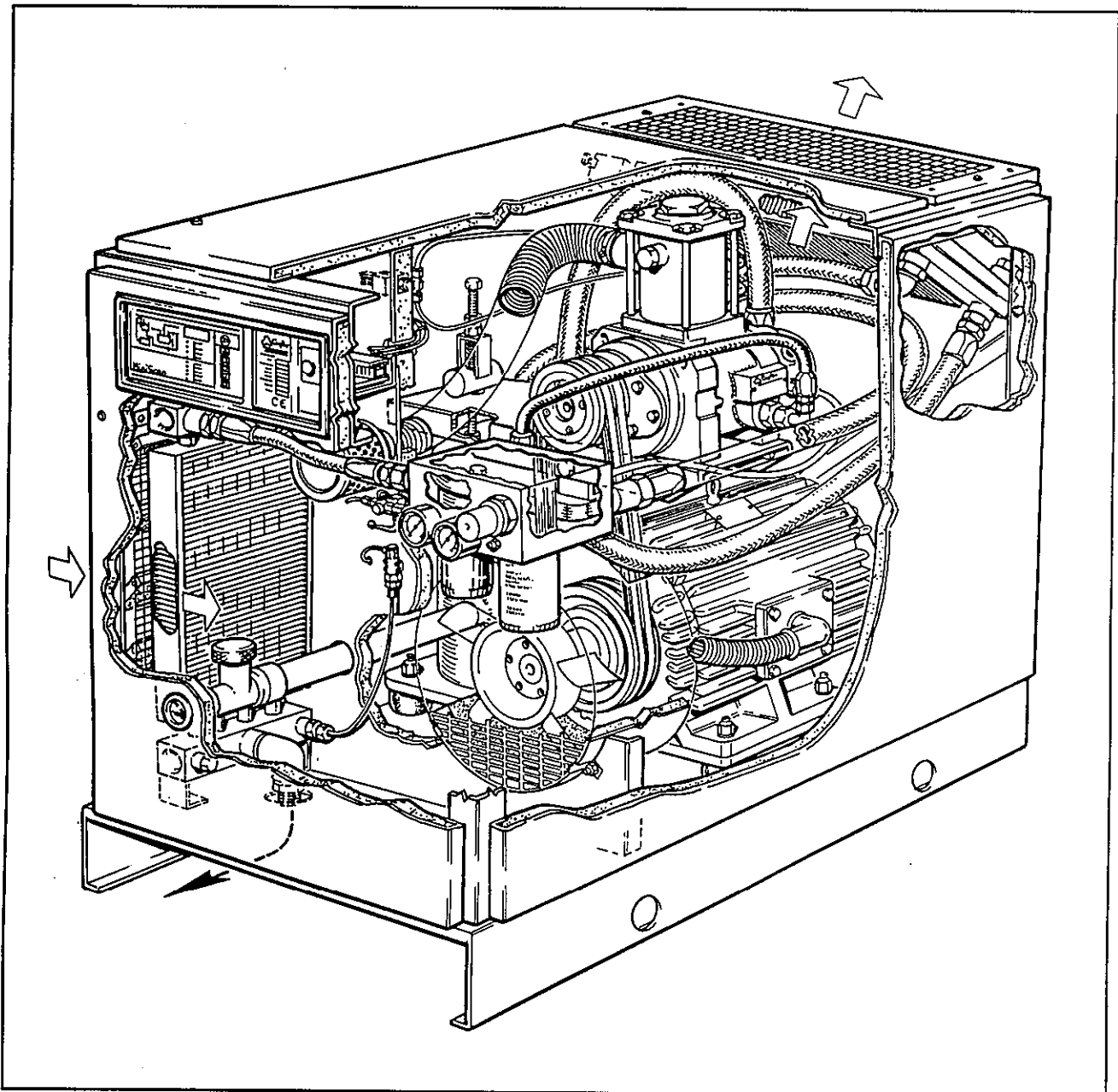


FIG. 2.1 GENERAL ARRANGEMENT

## 2. AIR-END (CYCLON 1 OR 2)

### 2.1 Description

The air is compressed in a single-stage, positive displacement, oil injected rotary screw air-end. The air-end is of the Cyclon type and comprises an intermeshing pair of helical screw rotors, male and female, mounted horizontally within an enclosed casing with drive being applied to the male rotor.

The male rotor in the Cyclon air-end is larger in diameter than the female rotor and has four lobes which mesh with five flutes on the female rotor. The rotors are asymmetric in profile to reduce blowback between the lobes on the compression cycle to a minimum, thus maximising overall sealing and efficiency.

The rotors are fitted with bearings at each end to provide radial and axial support, maintain adequate shaft stiffness and to give minimum clearance and low leakage between the rotor tip diameter and the casing.

At the delivery end the male and female rotors are fitted with a single taper roller bearing. These bearings provide axial and radial support of both rotors and control the very fine end clearances between the rotors and the casing.

Heavy duty parallel roller bearings are fitted to both rotors at the inlet end to provide radial support and to sustain the drive load of the male rotor.

### 2.2 Operation

Air enters the compressor unit through the intake filter and open suction regulator to the inlet port of the air-end. The air is trapped by the turning rotors and mixes with the oil which enters the casing through the oil injection point.

Continued rotor rotation increases the pressure and temperature of the air/oil mixture which passes from the air-end discharge pipe into the oil separator where primary separation takes place by centrifugal force. Most of the oil is separated at this stage and drops to the bottom of the vessel.

The remaining air/oil mixture then passes through a filter element where final separation takes place. The separated oil collects in the bottom of the filter and is scavenged back into the air-end through a small diameter pipe. The scavenge cycle is regulated by a solenoid valve controlled by a timer.

The filtered air then passes from the oil separation element by way of the minimum pressure/ non-return valve. Provided the air pressure at this stage is above 4 to 4.5 bar the air passes through the aftercooler where it is cooled before passing to the delivery outlet.

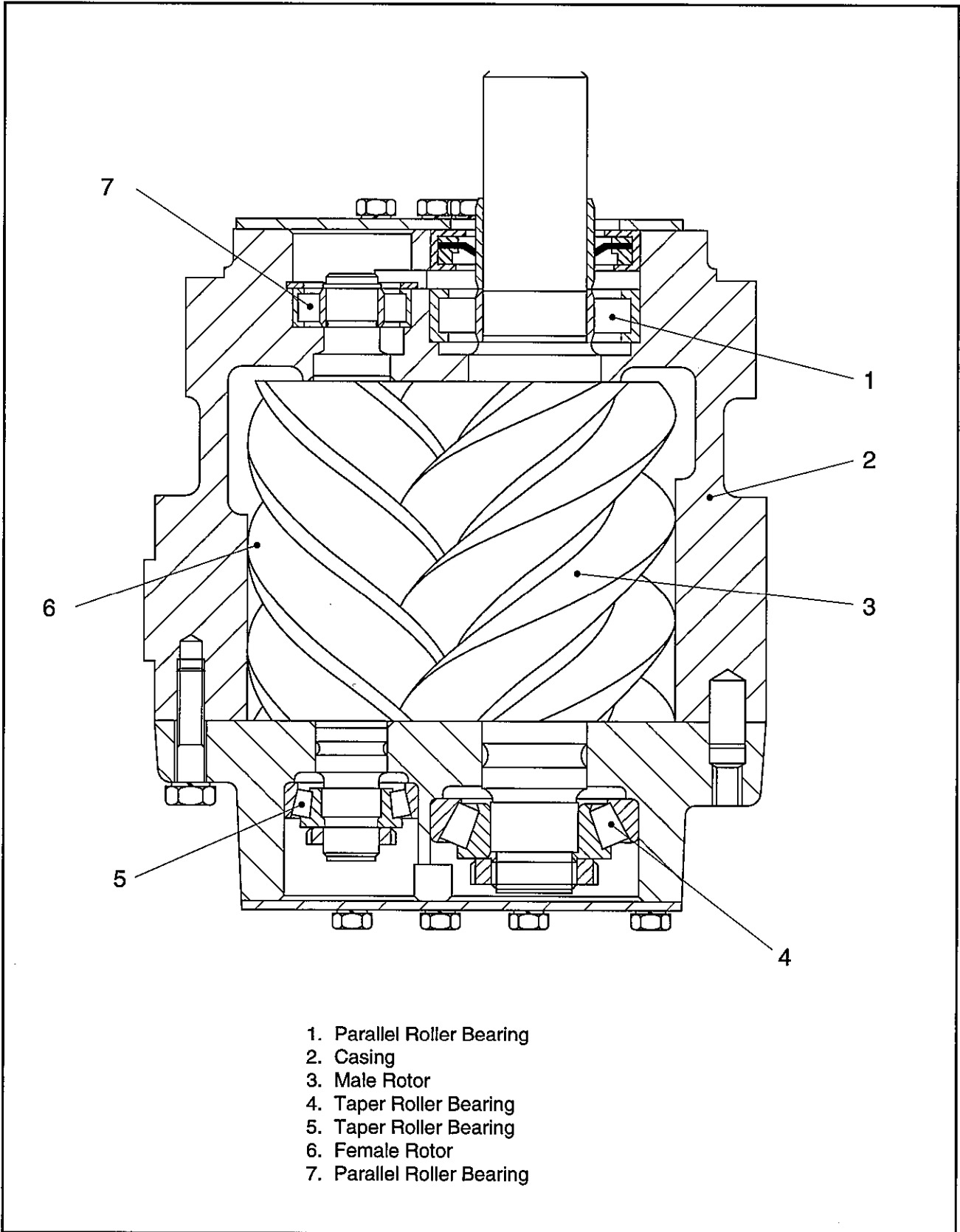
If the air pressure in the primary separator vessel falls below 4 to 4.5 bar the minimum pressure valve will close. The valve also incorporates a non-return valve which operates to prevent delivery air passing back into the separator when the compressor is running off-load.

Oil from the bottom of the separator flows under pressure to the oil cooler and during normal running the oil passes through the cooler to maintain the correct temperature. A thermostatic bypass valve is installed in the inlet manifold of the oil cooler.

When the compressor is started, the cold oil in the system bypasses the cooler and flows through the oil filter directly to the air-end. As the oil and air mixture is compressed by the rotors in the air-end, the temperature of the oil increases.

When the oil has reached its normal operating temperature the bypass valve closes and the oil is directed through the oil cooler. The cooled oil then flows to the oil filter where it is cleaned before entering the air-end.

The quantity of oil injected into the air-end is controlled by a restrictor orifice in the air-end casing. Oil is injected under pressure through the restrictor orifice into the rotors and a gallery supplies oil to the air-end bearings.



**FIG. 2.2 AIR-END - GENERAL ARRANGEMENT**

### **3. ELECTRONIC CONTROLLER**

The electronic control system is microprocessor based with an LED display panel, incorporating advanced control and monitoring features.

### **4. PROTECTION AND SAFETY EQUIPMENT**

In addition to the protection and warning circuits linked to the control panel the following protection devices are fitted:

#### **4.1 Relief Valve**

A pressure relief valve is mounted on the primary oil separator. If pressure continues to build up when the demand for compressed air has ceased, the relief valve will open at a pre-set level to discharge the excess pressure to atmosphere.

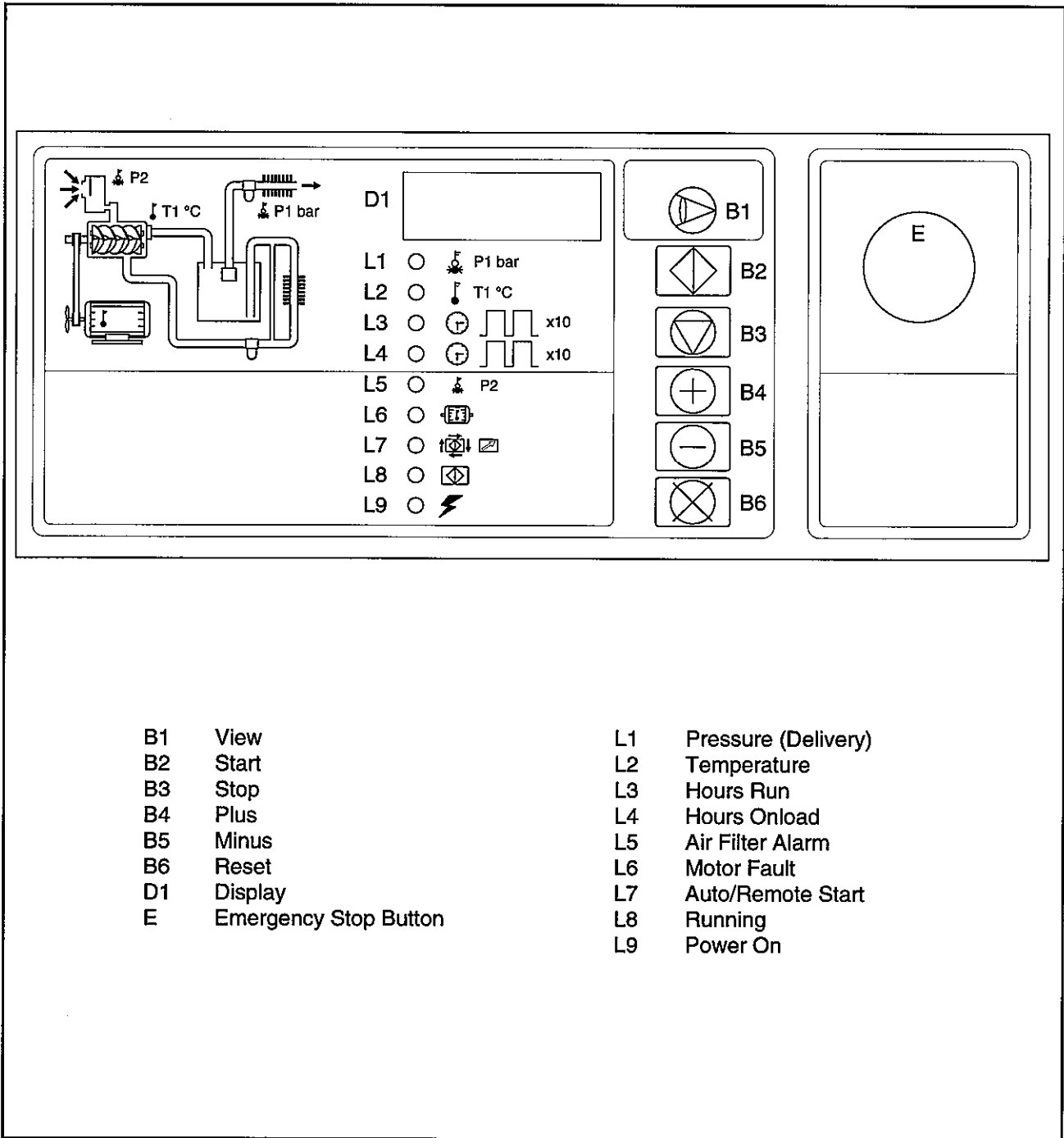
#### **4.2 Blowdown System**

Whenever the compressor shuts down, either automatically or by operation of a 'STOP' switch, all pressure in the oil separator vessel is automatically released by a blowdown system which vents the pressure to atmosphere. This ensures that the compressor is restarted in a no-load condition.

#### **4.3 Minimum Pressure/Non-return Valve**

Fitted on the filter manifold, the minimum pressure valve remains closed until minimum pressure is reached. This ensures a rapid build-up of pressure when the compressor first starts and also prevents high velocity, low pressure air reaching the user's pipework during the start-up period and carrying over excessive amounts of oil.

When the compressor shuts down the non-return valve prevents the pressure in the user's pipework feeding back into the oil separator and venting through the blowdown system.



SureScan

FIG. 2.3 CONTROL PANEL

## 5. AIR/OIL SYSTEM

### 5.1 Description

The air/oil system comprises an air intake filter, suction regulator, air-end, oil separator vessel, oil separator filter, minimum pressure/non-return valve, aftercooler, oil cooler with thermostatic bypass valve and an oil filter. The flow of oil through the circuit is achieved through the pressure differential existing between the primary oil separator and the oil injection point in the air-end.

### 5.2 Operation

Air enters the compressor unit through the intake filter (2) and open suction regulator (1) to the inlet port of the air-end (7). The air is trapped by the turning rotors and mixes with the oil which enters the casing through the oil injection point.

Continued rotor rotation increases the pressure and temperature of the air/oil mixture which passes from the air-end discharge pipe into the oil separator (4) where primary separation takes place by centrifugal force. Most of the oil is separated at this stage and drops to the bottom of the vessel.

The remaining air/oil mixture then passes through a filter element (5) where final separation takes place. The separated oil collects in the bottom of the filter and is scavenged back into the air-end through a small diameter pipe. The scavenge cycle is regulated by a solenoid valve controlled by a timer.

The filtered air then passes from the oil separator filter by way of the minimum pressure/ non-return valve (3). Provided the air pressure at this stage is above 4 to 4.5 bar the air passes through the aftercooler (9) where it is cooled before passing to the delivery outlet.

If the air pressure in the primary separator vessel falls below 4 to 4.5 bar the minimum pressure valve will close. The valve also incorporates a non-return valve which operates to prevent delivery air passing back into the separator when the compressor is running off-load.

Oil from the bottom of the separator flows under pressure to the oil cooler (10) and during normal running the oil passes through the cooler to maintain the correct temperature. A thermostatic bypass valve (14) is installed in the inlet manifold of the oil cooler.

When the compressor is started, the cold oil in the system bypasses the cooler and flows through the oil filter (8) directly to the air-end. As the oil and air mixture is compressed by the rotors in the air-end, the temperature of the oil increases.

When the oil has reached its normal operating temperature the bypass valve closes and the oil is directed through the oil cooler. The cooled oil then flows to the oil filter where it is cleaned before entering the air-end.

The quantity of oil injected into the air-end is controlled by a restrictor orifice in the air-end casing. Oil is injected under pressure through the restrictor orifice into the rotors and a gallery supplies oil to the air-end bearings.

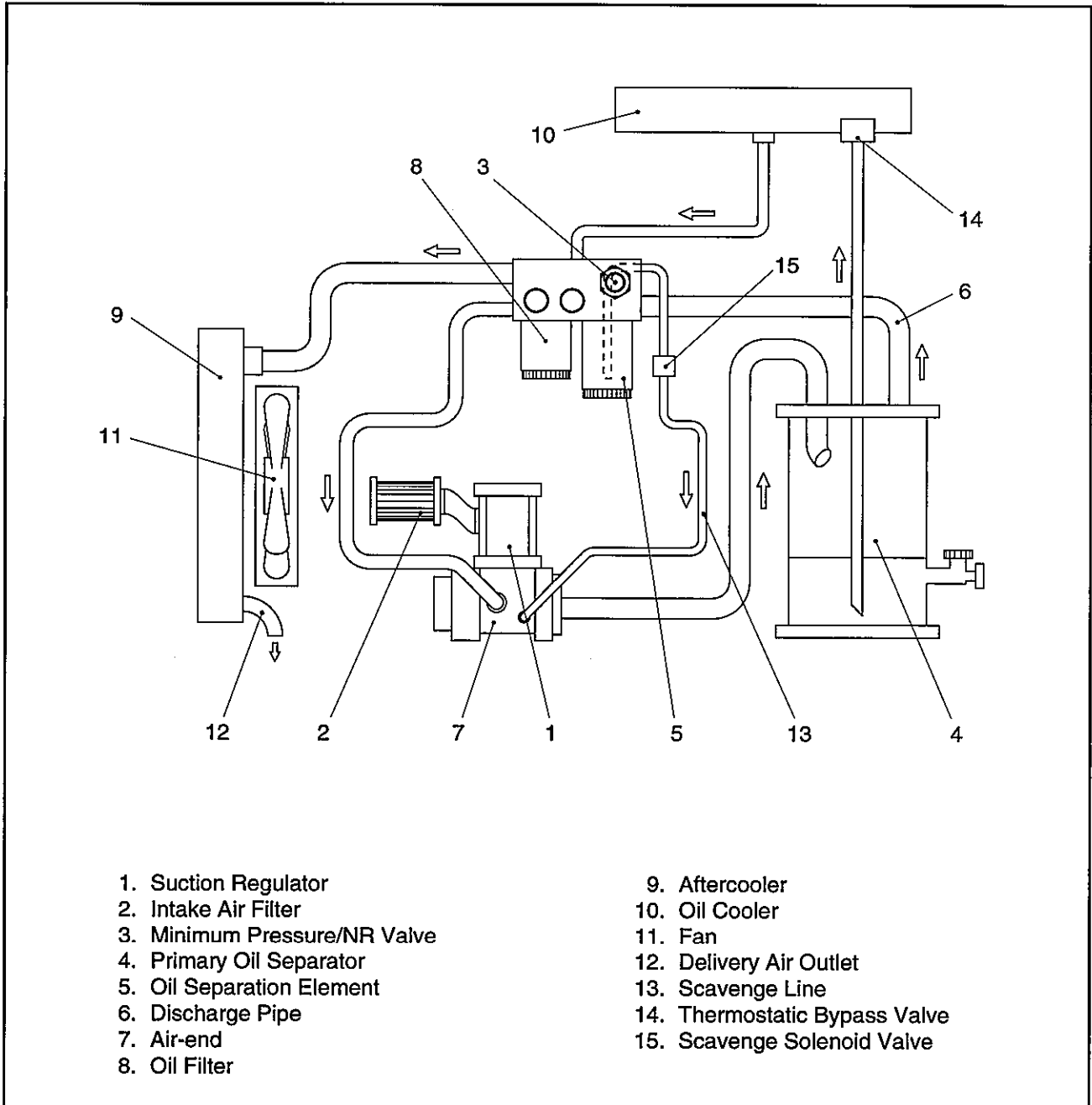


FIG. 2.4 AIR/OIL SYSTEM

## 6 REGULATION SYSTEM

### 6.1 Description

Control of the compressor unit is achieved through the combined operation of pneumatic, electrical and mechanical devices. The regulation system operates on the principle of full output (on-load) or no output (off-load).

### 6.2 Operation

The control system is designed to load and unload the compressor by opening or closing a pneumatically operated air inlet valve in the suction regulator in response to a signal provided by the electronic control system. The electronic controller uses a pressure transducer to measure air delivery pressure and provides a load/unload signal to the unloader solenoid valve.

The suction regulator incorporates a bleed and a blowdown system for the oil separator together with an off-load noise reduction system.

#### 6.2.1 Compressor Stopped; Power On

The suction regulator inlet valve (17) is held closed by a return spring (16) and another spring (2) holds the piston (3) in position at the bottom of the cylinder. The unloader solenoid (5) is de-energised with the valve in the open position. This provides an air connection between the oil separator (8), port A (4) of the suction regulator and through a non-return valve (13) to port B (14). The minimum pressure / non-return valve (7) is closed, isolating the separator from the user's air system.

#### 6.2.2 Compressor Starting

The compressor will start providing the delivery pressure is below the lower set point P2. The depression created by the turning rotors causes a partial vacuum at the compressor intake which lifts the inlet valve (17) off its seat against the light load of the spring (16). This allows air to be drawn through the air-end (9) to pressurise the separator (8). The minimum pressure/non-return valve (7) remains closed.

Air passes from the separator and through the open unloader solenoid valve (5) to the underside of the piston (3) via port A (4). At 0.2 - 0.4 bar the pressure will exceed the force of the spring (2) causing the piston and stem (15) to lift, closing the inlet valve.

To minimise the starting current the motor control circuit ensures that the motor is run up to speed in Star connection. After a short time delay the control circuit switches the motor to Delta and after a further short delay the unloader solenoid valve is energised to close.

When the unloader solenoid valve closes, air from the underside of the piston is exhausted to atmosphere via jet A. The piston then moves down under the force of the spring allowing the inlet valve to open and the compressor to run on-load.

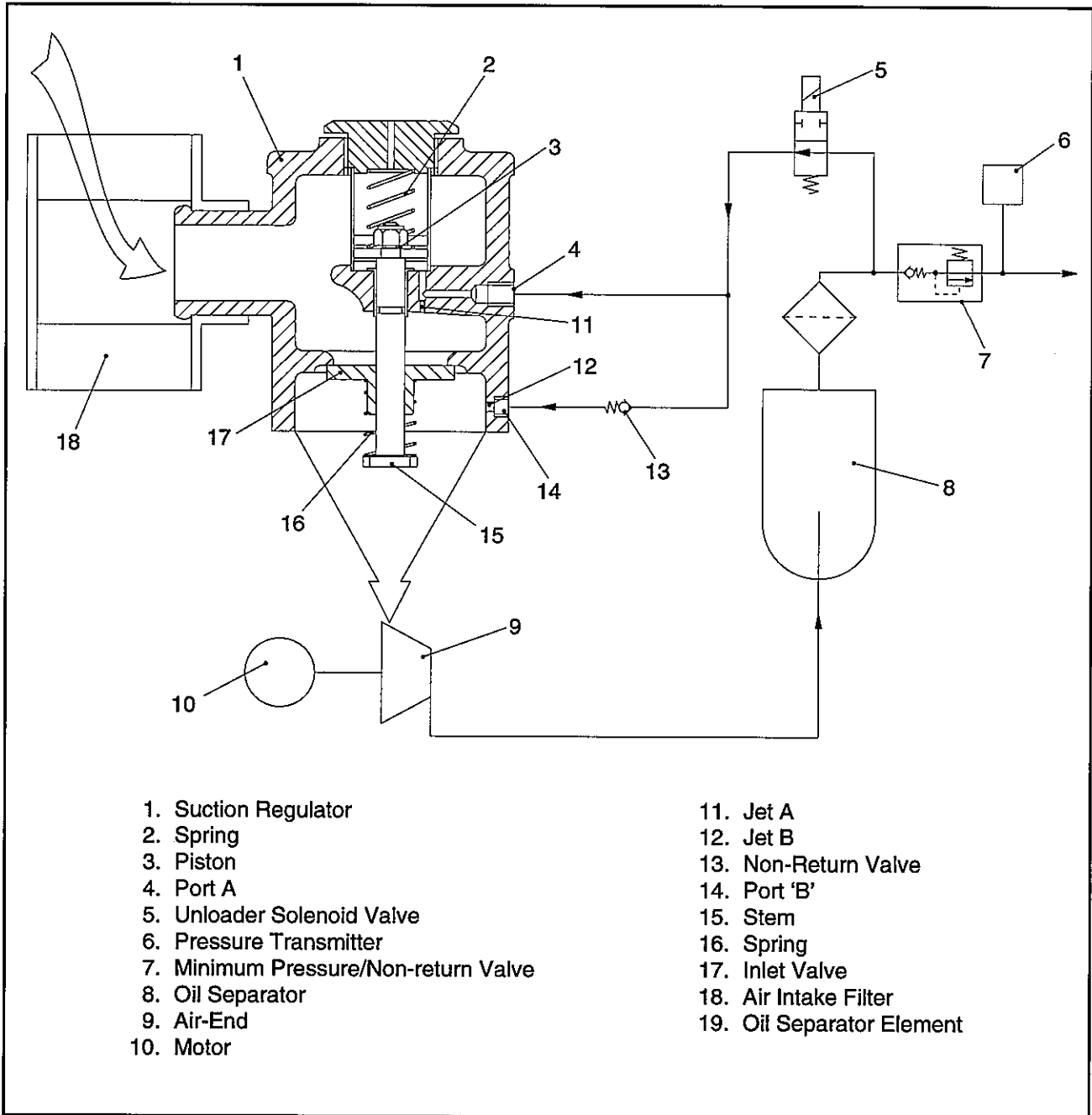
#### 6.2.3 Compressor Running

As the air pressure in the separator rises quickly to between 4 and 4.5 bar the minimum pressure valve opens and delivery air passes into the user's system. When the pressure reaches the upper set point P1 the controller de-energises the unloader solenoid and the valve opens. This allows air from the separator vessel to pass via port A (4) to the underside of the piston which lifts against the force of the spring and closes the inlet valve, causing the compressor to run off-load.

At this point air is exhausted to atmosphere through jet A (11), reducing the pressure in the separator to approximately 2.2 bar whilst running off-load. The system is balanced at 2.2 bar by the ratio between jet A, jet B and the 3 mm orifice in the unloader solenoid valve. The non-return valve then closes to prevent air from the system flowing back to the separator.

To reduce noise when running off-load, air is directed from the separator and through jet B (12) to reduce the pressure ratio across the air-end and the vacuum in the compressor inlet.

When the controller switches the compressor to run off-load, a run-on time sequence is activated. This allows the compressor to run for a pre-set period of time off-load. If this time elapses before the pressure in the system has fallen to the lower set point, the controller de-energises the drive motor (10) and the compressor stops.



**FIG. 2.5 REGULATION SYSTEM (SCHEMATIC)**

#### 6.2.4 Stopping the Compressor

The compressor may be stopped through manual operation of the stop switch, emergency stop or automatically by the controller due to low air demand. In each case the unloader solenoid valve is de-energised, and air is directed from the oil separator into the suction regulator to unload the compressor.

The inlet valve returns to its seat and prevents the air/oil mixture from blowing back through the intake. The non-return valve (13) in the line prevents the air/oil mixture from blowing back through jet B (12). The air in the separator is exhausted to atmosphere via the unloader solenoid valve through jet A (11).



---

# CHAPTER

# 3

## LEADING PARTICULARS, INSTALLATION & COMMISSIONING

<b>Description</b>	<b>Page</b>
Leading Particulars	1
Installation	4
Guidelines	4
Installation Procedure	5
Commissioning	6
Commissioning Procedure	6
Preliminary Checks	6
Pressure Calibration	7
Checking/Altering Program Mode Values	8
Final Checks	10
Commissioning Check List	12

---



## LEADING PARTICULARS

Model			Cyclon 105	Cyclon 107
Air-end	Single stage oil injected screw	Cyclon	1	1
Total oil capacity:		litres	6 1/2	6 1/2
Delivery air connection:		G	3/4	3/4
Ambient air temperature operating range:	Minimum Maximum	°C °C	0 46	0 46
Delivery air pressure:	Minimum (all models) Maximum (see compressor data plate)	bar bar	5 7.5-14	5 7.5-14
Typical delivery air temperature above ambient (full load operation)		°C	6	6
Typical cooling air outlet temperature above ambient (at maximum delivery pressure)		°C	15	20
Main drive motor (standard 400V, IP55):	Nominal Rating (for actual rating see motor data plate) Speed	kW rpm	5.5 2960	7.5 2960
Typical total input power	Note: For actual figures see compressor data plate	kW	6.88	9.27
Approximate weight of total package		kg	286	292
Dimensions, enclosed models:	Length Width Height	mm mm mm	760 710 925	760 710 925
Average Sound Level	at 1 m (CAGI PNEUROP)	dB(A)	66	67



Model			Cyclon 111	Cyclon 215
Air-end	Single stage oil injected screw	Cyclon	1	2
Total oil capacity:		litres	6 1/2	15
Delivery air connection:		G	3/4	1 1/4
Ambient air temperature operating range:	Minimum Maximum	°C °C	0 46	0 46
Delivery air pressure:	Minimum (all models) Maximum (see compressor data plate)	bar bar	5 7.5-14	5 7.5-14
Typical delivery air temperature above ambient (full load operation)		°C	6	10
Typical cooling air outlet temperature above ambient (at maximum delivery pressure)		°C	18	16
Main drive motor (standard 400V, IP55):	Nominal Rating (for actual rating see motor data plate) Speed	kW	11	15
		rpm	2960	2960
Typical total input power	Note: For actual figures see compressor data plate	kW	13.59	18.13
Approximate weight of total package		kg	351	489
Dimensions, enclosed models:	Length	mm	1000	1165
	Width	mm	710	710
	Height	mm	925	1252
Average Sound Level	at 1 m (CAGI PNEUROP)	dB(A)	68	68

Model			Cyclon 218	Cyclon 222
Air-end	Single stage oil injected screw	Cyclon	2	2
Total oil capacity:		litres	15	15
Delivery air connection:		G	1 <sup>1</sup> / <sub>4</sub>	1 <sup>1</sup> / <sub>4</sub>
Ambient air temperature operating range:	Minimum Maximum	°C °C	0 46	0 46
Delivery air pressure:	Minimum (all models) Maximum (see compressor data plate)	bar bar	5 7.5-14	5 7.5-14
Typical delivery air temperature above ambient (full load operation)		°C	10	10
Typical cooling air outlet temperature above ambient (at maximum delivery pressure)		°C	19	18
Main drive motor (standard 400V, IP55):	Nominal Rating (for actual rating see motor data plate) Speed	kW rpm	18.5 2960	22 2960
Typical total input power	Note: For actual figures see compressor data plate	kW	22.1	26.1
Approximate weight of total package		kg	504	517
Dimensions, enclosed models:	Length Width Height	mm mm mm	1165 710 1252	1165 710 1252
Average Sound Level	at 1 m (CAGI PNEUROP)	dB(A)	69	69

## INSTALLATION

WARNING

- Refer to the safety procedures before installation of the compressor unit.

- Lethal voltages are used in this equipment. Use extreme caution when carrying out electrical checks. Isolate the power supply before starting any maintenance work.

### 1. GUIDELINES

Study the installation information in the manual for the particular compressor concerned.

The compressor unit is supplied as a complete package and does not need securing to a foundation. However, the supporting floor must have a loading capacity sufficient to support the weight of the unit (see 'Leading Particulars').

Because in operation the compressor will release heat into the surroundings the compressor room should be of adequate size and have good ventilation. The recommended minimum sizes of room and ventilation openings can be estimated as follows:

From 'Leading Particulars' establish total input power (kW).

Room volume = 1.35 m<sup>3</sup> per input kW

Ventilation opening = 0.016 m<sup>2</sup> per input kW

**Note:** An equivalent discharge opening will also be necessary.

**Example:**

Cyclon 111 input kW = 13.6

Room volume = 13.6 x 1.35 m<sup>3</sup> = 18.4 m<sup>3</sup>

Ventilation opening = 13.6 x 0.016 m<sup>2</sup> = 0.22 m<sup>2</sup>

The ventilation inlet opening should be positioned as low down as possible. The outlet opening should be positioned as high up as possible, preferably in the roof or ceiling.

The air flow from the cooler outlet may be directed either vertically or horizontally simply by altering the position of the outlet duct which is secured by four 1/4 turn fasteners. The air can be ducted for a distance of up to 3 m if necessary without the need for an additional fan. Details are available on request from the local CompAir BroomWade distributor.

To allow adequate air circulation, provide a minimum of 1.5 m headroom above the compressor and a minimum of 50 mm clearance on the RH side. Compressors with horizontal cooling air discharge must have a minimum of 1 m and those with vertical discharge a minimum of 150 mm clearance at the back. There should be no obstruction of doorways, passages or walkways.

The only connections required to the compressor are as follows:

1. Electrical power supply, 3-phase plus earth.
2. Air delivery outlet to the user's main pipework using a flexible hose (optional) or solid pipe.

Model	Flexible Hose
105/107/111	C27312-155
215/218/222	C27323-115

**Note:** If solid pipe is used remove the coned nipple and ensure the first clamp or support is at least 1 m from the compressor discharge.

If the compressor is to be coupled in parallel with another compressor or connected to an existing air supply system, additional steps must be taken as set out in Chapter 1 'Safety Procedures'.

If air usage is intermittent or rapidly fluctuating so that the instantaneous demand for air is likely to exceed the compressor output rating, and if the volume of the user's pipework is small, it will be necessary to install a receiver of appropriate capacity.

As a guide, if the volume of the user's pipework is less than 1 m<sup>3</sup> a receiver of 875 litres minimum capacity should be installed.

To maintain rigidity during shipment, transportation fixings (painted red) are fitted to the drive module, for removal after installation.

## 2. INSTALLATION PROCEDURE

The following procedure gives guidance for installing a standard compressor unit. For the installation details for non-standard units or units equipped with optional equipment refer to the local CompAir BroomWade distributor.

1. Using a fork lift, lift the compressor unit and move it into position.

**Note:** If the unit is to be located in a RH corner carry out items 5 and 6 before moving into position.

2. Lower the unit into place so that all the mounts make proper contact with the floor. Check that it settles level to within 3 mm, using suitable packing pieces under the mounts if necessary.
3. Release 1/4 turn fasteners and remove the enclosure panels and packaging material to give access to the compressor.
4. Remove the transportation fixings (painted red) from the drive module. Remove all protective blanking covers and tapes. Remove the starter compartment top cover.

5. Remove the plain gland plates from the back of the unit and the starter compartment and drill to accept the power cable glands.
6. Make sure that the power supply to the compressor is taken from a fused isolator. The switch must be locked 'OFF' and the fuses removed.

Connect the power supply to the compressor in accordance with the diagram supplied, using cables which comply with the standards of the International Electrotechnical Commission (I.E.C.) or local regulations.

The cables must be protected and clamped. A bar is fitted to support the cable between the gland plates.

7. Connect the air delivery pipe to the user's pipework through an isolating shut-off valve.
8. Position the exhaust panel to discharge vertically or horizontally by releasing four 1/4 turn fasteners and rotating the panel as required. Secure the fasteners.
9. Refit the starter compartment top cover and enclosure panels.

## COMMISSIONING



### WARNING



- Refer to the safety procedures before commissioning the compressor unit.
- Lethal voltages are used in this equipment. Use extreme caution when carrying out electrical checks. Isolate the power supply before starting any maintenance work.

### 1. COMMISSIONING PROCEDURE

When commissioning a new compressor or re-commissioning a compressor which has been out of service, carry out the following procedures before attempting to start:

**Note:** We recommend that commissioning is carried out by a CompAir BroomWade distributor.

#### 1.1 Preliminary Checks

1. Check that the isolator switch is locked 'OFF' and that all pipework and electrical power connections are correct and tight.
2. Release 1/4 turn fasteners and remove the top and side panels from the compressor.
3. Check all screws and connections in the starter area for security. Check all electrical connections are made correctly and are tight.
4. Ensure the main supply cables and fuse ratings comply with regulations.
5. Ensure the control transformer primary tapping connections are correct for supply voltage.
6. Ensure main motor thermal overload is set correctly for motor F.L.C. and supply voltage.
7. Remove panels as required to gain access to motor connections. Inspect the motor and wiring connections to make sure they are correct and secure.
8. Check that all connections on the rear of the controller are correct and secure.
9. Check that all protective blanks and tapes have been removed.
10. Check the oil level and if necessary top up the separator vessel to the correct level with BroomWade approved lubricant (see 3.4.2 under 'Maintenance Procedures').
11. Check the drive belt tension and adjust if necessary. (see 3.5 'Drive Belt' under 'Maintenance Procedures').

## 1.2 Pressure Calibration

**Note:** The values shown throughout these procedures are examples only. Ensure set values are compatible with the compressor model.

No.	Action	Reason	Display
1.	Switch power 'ON' at the isolator and allow the controller to initialise.		0.0 Bar
2.	Press the <i>STOP</i> button, even if the compressor is already stopped.		0.0 Bar
3.	Disconnect the air pipe from the pressure transmitter.	To apply 0.0 Bar to the pressure transmitter	0.0 Bar
4.	Press and hold the <i>STOP</i> , <i>PLUS</i> and <i>MINUS</i> buttons together.	To enter the Pressure calibration mode	0.0 Bar
5.	After five seconds indicators L1 to L8 will flash four times. When the indicators start to flash release the <i>STOP</i> , <i>PLUS</i> and <i>MINUS</i> buttons.	To enter Pressure calibration mode. The 0.0 Bar calibration set point is automatically set when pressure calibration mode is entered.	0.0 Bar
6.	Apply an accurately known pressure, above 5.5 Bar, to the pressure transmitter.	(example - 7.0 bar)	7.1 Bar
7.	Press <i>PLUS</i> or <i>MINUS</i> until the pressure display matches the applied pressure.	To calibrate the pressure transmitter to the applied pressure.	7.0 Bar
8.	Press <i>STOP</i>	To enter the pressure calibration into the controller memory. (The display will return to normal running mode).	7.0 bar
9.	Remove the slave air supply and re-connect the air pipe to the pressure transmitter.		0.0 Bar

### 1.3 Checking/Altering Program Mode Values

**Note:** The values shown throughout these procedures are examples only. Ensure set values relate to compressor model.

No.	Action	Reason	Display
1.	Switch power 'ON' at the isolator and allow the controller to initialise.		0.0 Bar
2.	Press the <i>STOP</i> button, even if the compressor is already stopped.		0.0 Bar
3.	Press and hold the <i>PLUS</i> and <i>MINUS</i> buttons together.	To enter Program mode	0.0 Bar
4.	After five seconds indicators L1 to L8 will flash four times. When the indicators start to flash release the <i>PLUS</i> and <i>MINUS</i> buttons.		0.0 Bar
5.	Indicator L1 will light and the display will show the upper pressure set point P1.		7.5 Bar
6.	Press <i>PLUS</i> or <i>MINUS</i> or go to step 8 if no adjustment required.	To adjust the displayed value	7.0 bar (pulsing display)
7.	Press <i>STOP</i>	To program the new value in to the controller memory	7.0 bar (steady display )
8.	Press <i>VIEW</i>	To step to the next option	115°C
9.	Indicator L2 will light and the display will show the oil temperature trip set point.		115°C
10.	Press <i>PLUS</i> or <i>MINUS</i> or go to step 12 if no adjustment required.	To adjust the displayed value	110°C (pulsing display)
11.	Press <i>STOP</i>	To program the new value in to the controller memory	110°C (steady display)
12.	Press <i>VIEW</i>	To step to the next option	
13.	Indicator L5 will light and the display will show the lower pressure set point P2.		7.0 bar

No.	Action	Reason	Display
14.	Press <i>PLUS</i> or <i>MINUS</i> or go to step 16 if no adjustment required.	To adjust the displayed value	6.5 bar (pulsing display)
15.	Press <i>STOP</i>	To program the new value in to the controller memory	6.5 bar (steady display)
16.	Press <i>VIEW</i>	To step to the next option	
17.	Indicator L6 will light and the display will show the compressor model		C215
18.	Press <i>PLUS</i> or <i>MINUS</i> until the displayed model matches the model number shown on the compressor data plate.	To adjust the displayed value	C111 (pulsing display)
19.	Press <i>STOP</i>	To program the new value in to the controller memory	C111 (steady display)
20.	Press <i>VIEW</i>	To step to the next option	
21.	Indicator L7 will light and the display will show the Auto restart delay time.		0 secs
22.	If the auto restart facility is required press <i>PLUS</i> or <i>MINUS</i> . If the facility is not required set the display to 0 seconds, this will disable the facility.	To adjust the displayed value	60 secs (pulsing display)
23.	Press <i>STOP</i>	To program the new value in to the controller memory	60 secs (steady display)
24.	Press <i>VIEW</i>	To step to the next option	
25.	Indicator L8 will light and the display will show the Run-on time.		3 mins
26.	Press <i>PLUS</i> or <i>MINUS</i> or go to step 28 if no adjustment required.	To adjust the displayed value	5 mins (pulsing display)
27.	Press <i>STOP</i>	To program the new value in to the controller memory	5 mins (steady display)
28.	Press <i>RESET</i>	To exit Program mode.	0.0 Bar

## 1.4 Final Checks

No.	Action	Reason	Display
1.	Switch power 'ON' at the isolator and allow the controller to initialise.		0.0 bar
2.	Press <i>START</i>  <b>Note:</b> The motor may appear to turn slowly for the first few revolutions before beginning to run up to speed. This is normal and should not be considered a fault condition. <b>CAUTION:</b> Do not repeatedly start and stop the compressor.	To start the compressor and check direction of rotation  May cause motor overheating, contactor damage or air-end seizure.	0.0 Bar
3.	Press <i>STOP</i> as soon as the motor begins to rotate. <b>CAUTION:</b> Do not allow prolonged running in the reverse direction as damage will be caused.		0.0 Bar
4.	If the direction of rotation ( marked by an arrow on the inside of the service panel) is incorrect, isolate the power supply and change over motor connections U1 and V1 on the main contactor and connections U2 and V2 on the delta contactor. Return to step 1.		
5.	Press <i>START</i> and run the compressor on load until the oil has reached working temperature. Check that the oil bypass valve operates correctly by feeling the rise in temperature of the upper header of the oil cooler when the valve opens.		
6.	Press <i>STOP</i> . Check that the blowdown system operates correctly and that both pressure gauges registers zero when blowdown ceases.		
7.	Top up the oil in the separator vessel to the correct level.		
8.	Simulate a demand for air by opening a drain valve of the downstream air receiver, if installed, or opening a valve in the user's pipework.		

---

No.	Action	Reason	Display
9.	Replace all compressor enclosure panels. <b>CAUTION:</b> The compressor will overheat if run without enclosure panels for any length of time.		
10.	Press START and run the compressor. Check that the compressor loads and unloads correctly according to the programmed pressure set points.		
11.	Check that the oil separator scavenge solenoid operates correctly according to the pre-set solenoid open and closed times. (It will be necessary to remove the service panel for short periods).		
12.	Check that, after running off load for the programmed run-on time, the compressor stops in to Standby mode.		
13.	Check that the compressor automatically re-starts when pressure falls below the lower pressure set point P2.		
14.	Run the compressor for 30 minutes. Check for air/oil leaks. (It will be necessary to remove the enclosure panels for short periods). Stop the compressor and rectify any leaks. <b>CAUTION: RISK OF HIGH PRESSURE</b> Do not use hands to locate leaks in the system. Always use a piece of paper or card for this purpose.		
15.	Stop the compressor and check that all enclosure panels are secure.		

---

## 2. COMMISSIONING CHECK LIST

- |  |  |
|--|--|
| 1. Protective blanks and tapes removed. ....             | 14. Controller model option set. ....                |
| 2. Pipework connected and checked. ....                  | 15. Scavenge solenoid timer checked. ....            |
| 3. All electrical connections checked. ....              | 16. Regulation air system isolating valve open. .... |
| 4. All control system connections checked. ....          | 17. Oil drain valve closed. ....                     |
| 5. Cable and fuse ratings comply with regulations. ....  | 18. Motor rotation correct. ....                     |
| 6. Control transformer input voltage set correctly. .... | 19. Corrosion inhibitor dispersed. ....              |
| 7. Overload set correct for motor size and voltage. .... | 20. Compressor operation correct. ....               |
| 8. Oil level correct. ....                               | 21. Oil/air fittings checked. ....                   |
| 9. Air-end primed. ....                                  | 22. Oil temperature within limits. ....              |
| 10. Drive belt tension correct. ....                     | 23. Emergency stop checked. ....                     |
| 11. Air-end and motor rotate freely. ....                | 24. Compressor test run for 30 minutes. ....         |
| 12. Pressure transmitter calibrated. ....                | 25. Oil level topped up. ....                        |
| 13. Pressure set-points set. ....                        | 26. All settings and options recorded. ....          |

---

# CHAPTER

# 4

## OPERATION AND FAULT FINDING

Description	Page
Operation	1
Routine Operation	1
Starting	1
Standby Mode	1
Stopping	2
Emergency Stop	2
Oil Temperature And Hours Run Display	2
Alarms And Shutdown Trips	2
Oil Separator - Scavenge Operation	3
Power Supply Failure Detection	3
Control Panel Indicators	4
Program Mode	4
Program Mode Routine	4
Program Mode Setting Definitions	5
Program Mode Settings	5
Fixed Parameters	6
Pressure Calibration Mode	6
Pressure Calibration Routine	6
Control Function Options	7
Automatic Re-Start	7
Remote Start/Stop Facility	7
Remote Load/Unload	7
Remote Group Fault Output	9
Fault Finding	10
Fault Indications	10
Trip Fault Indications	10
Alarm Fault Indications	11
Shutdown Faults	11
Alarm Faults	12

---

## OPERATION



### WARNING



- Refer to the safety procedures before operating the compressor unit.

- Lethal voltages are used in this equipment. Use extreme caution when carrying out electrical checks. Isolate the power supply before starting any maintenance work.

### 1. ROUTINE OPERATION

#### 1.1 Starting

1. Switch mains power ON at the isolator. The display will show the control program identification and the Power on indicator (L9) will light.
2. After a few seconds the Delivery pressure indicator (L1) will light and the display will show the delivery pressure in Bar. See 1.5 'Oil temperature and Hours run display'.
3. The Remote start/Auto restart indicator (L8) will light if the Remote start or Auto restart facilities have been selected. See 4 'Control Function Options'. If a fault exists, one of the alarm or trip indicators will flash. See 1.9 'Control Panel indicators' for possible start-up faults.
4. To start the compressor press *START* (B2).

**Note:** the compressor motor may appear to turn slowly for the first few revolutions before running up to speed. This is normal and should not be considered a fault condition.

**CAUTION:** Do not repeatedly start and stop the compressor.

5. Provided pressure at the delivery point is below the P2 pressure set point the compressor will start and run. If pressure is above the P2 set point the compressor will enter 'Standby' mode and the Start indicator (L8) will flash. The compressor will automatically start and run when delivery pressure falls below the P2 set point.
6. The compressor will not start from the front panel if the Remote start facility is enabled.

7. During the initial starting period, the drive motor starts in Star connection. Following the switch from Star to Delta a two seconds load delay time will occur before the compressor runs on load. The compressor will load and unload according to the delivery pressure set points P1 and P2.

**Note:** When the compressor is on-load, a small light will appear in the lower left hand side of the display to indicate the compressor is in the loaded condition. This is intended as a fault diagnostic aid only.

8. Initially the oil temperature will rise rapidly to working temperature, the thermostatic bypass valve will then operate to maintain the temperature at normal working level.
9. Fault conditions are continuously monitored from start-up and an alarm or trip indicator will flash if a fault occurs.
10. To interrogate the Oil temperature or to view the Hours run press *VIEW* (B1). See 1.5 'Oil temperature and Hours run display'.

#### 1.2 Standby Mode

1. If the compressor is off-load for longer than the programmed 'Run-on time', the compressor will stop and the 'Start' indicator (L8) will flash slowly for a short period of time while the compressor blows down.
2. The Start indicator will flash quickly to indicate the compressor is in the Standby mode. The compressor will start automatically when the delivery pressure falls below the P2 pressure set point.

### 1.3 Stopping

1. To stop the compressor press *STOP* (B3). This initiates a controlled shut down sequence. The compressor will unload, the drive motor will stop and the Start indicator (L8) will flash slowly for the blowdown period. See 2.3 'Program mode settings'.

**Note:** The drive motor will continue to run for 30 seconds if the compressor is stopped when running on-load (or within 30 seconds of running on-load).

2. The compressor motor cannot be re-started during the blowdown sequence. If *START* (B2) is pressed the start indicator will flash quickly and the compressor will enter the Standby mode and start automatically when the blowdown time expires.

**CAUTION:** The compressor should not be stopped during a start sequence.

### 1.4 Emergency Stop

1. When *EMERGENCY STOP* is pressed, the compressor will stop immediately and the unit will blow down.
2. Indicators L1 to L8 will flash to show *EMERGENCY STOP* has been pressed.
3. If the *EMERGENCY STOP* button is reset and *RESET* (B6) pressed during the blowdown time, the Start indicator will slow flash for the remainder of the normal blowdown time.

**CAUTION:** The Emergency Stop button should be used only in a genuine emergency and must not be used as the normal method of stopping the compressor.

### 1.5 Oil Temperature and Hours Run Display

1. When the compressor is in normal running mode indicator L1 will be lit and the display will show the delivery pressure in Bar.

2. To interrogate the oil temperature, total hours run or hours run on-load, press *VIEW* (B1).
3. Each time *VIEW* is pressed the next indicator in the sequence L1 to L4 will light and the display will show the corresponding value.

Indicator	Display
L1	Delivery Pressure in Bar
L2	Oil Temperature in °C
L3	Total hours run
L4	Hours run on-load

**Note:** The hours run displays must be multiplied by 10 to obtain the correct hours reading. For example, if the Total hours run display shows '123.4' the actual hours run is 1234.0 hours.

The display will reset to show delivery pressure 60 seconds after *VIEW* is last pressed.

### 1.6 Alarms and Shutdown Trips

1. If an alarm condition occurs and service attention is required the appropriate alarm indicator will flash.
2. If a trip condition occurs the compressor will stop and the appropriate trip indicator will flash. This can occur any time after the compressor has been started. See 1.9 'Control panel indicators'.
3. The oil temperature alarm and oil temperature trip conditions are shown by indicator (L2) flashing. Indicator (L2) will flash slowly for an alarm condition and the compressor will continue to run. Indicator (L2) will flash quickly for a trip condition and the compressor will shut down immediately.
4. The oil temperature alarm level is automatically set 10°C below the programmed oil temperature trip level. See 1.9 'Program mode'.

**1.7 Oil Separator - Scavenge Operation**

The oil separator scavenge solenoid valve cycles continuously according to the set 'open' and 'shut' times.

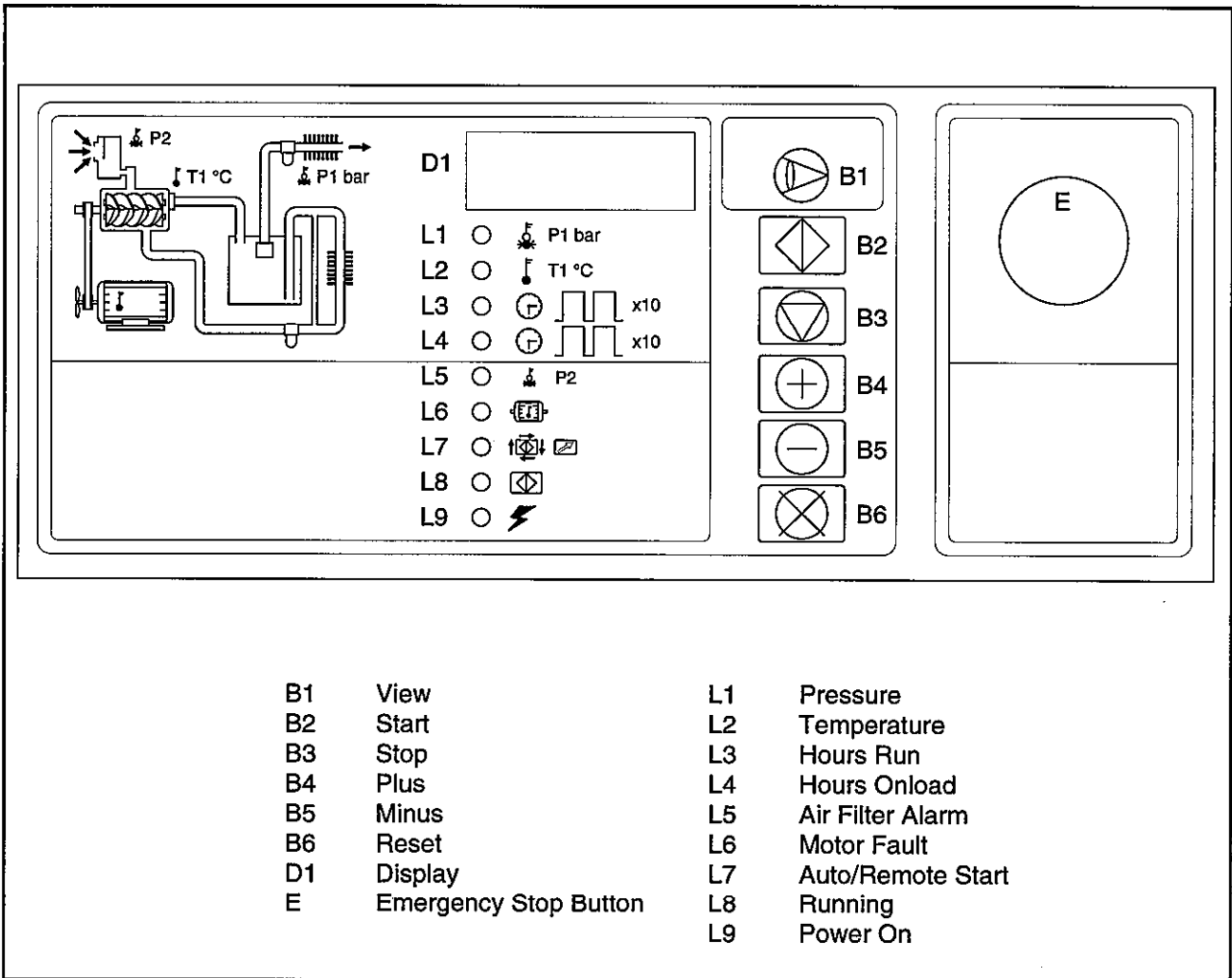
**1.8 Power Supply Failure Detection**

The controller is designed to withstand power supply failures of up to 0.5 seconds without loss of control when the main motor is **not** running. When the main motor **is** running, power supply failures of up to 0.5 seconds will cause the motor contactors to de-energise momentarily, disrupting normal operation.

To prevent this occurrence the controller is equipped with a power supply failure detection facility which is activated while the main motor is running. If a power supply failure is detected, the compressor will stop, the controller will reset, and the display will show three horizontal lines in the left hand side of the display after the controller has been re-initialised.

If the power failure Auto-restart facility is enabled, the compressor will automatically restart.

**Note:** This facility is designed to detect total loss of power, not a drop in normal supply voltage.



**FIG. 4.1 CONTROL PANEL**

**1.9 Control Panel Indicators**

Indicator	When on (Steady)	When flashing
L1	Display will show delivery pressure	Excess pressure trip
L2	Display will show oil temperature	High oil temp alarm (slow flash) High oil temp trip (quick flash)
L3	Display will show total hours run	
L4	Display will show hours run on-load	
L5		Change air filter alarm
L6		Drive motor trip
L7	Remote control / Auto restart enabled	Auto restart warning
L8	Compressor started	Standby (quick flash) Blowing down (slow flash)
L9	Main supply power ON	

**2. PROGRAM MODE**

**2.1 Program Mode Routine**

'Program mode' is used to access, view and/or alter the operating parameters and options stored in the memory of the controller.

1. To enter the 'Program mode' press *STOP* (B3) then press and hold *PLUS* (B4) and *MINUS* (B5) together.
2. After five seconds indicators L1 to L8 will flash four times to indicate that the controller has entered 'Program mode'. Release *PLUS* and *MINUS* buttons when the indicators start to flash.
3. After the indicators have flashed four times, indicator L1 will remain lit and the display will show the current upper pressure set point P1.
4. When *VIEW* (B1) is pressed indicator L1 will extinguish and indicator L2 will light. The display will now show the Oil temperature trip setting.
5. Each time *VIEW* is pressed the next indicator in the sequence L1, L2 then L5 to L8 will light and the display will show the appropriate option.
6. To alter a displayed setting, press *PLUS* (B4) or *MINUS* (B5) to adjust the displayed value. The display will flash when an adjustment is made. When the display shows the required value, press *STOP* (B3) to enter the new value in to the controller memory. The display will show the new setting as a steady value.
7. Press *RESET* (B6) to return to normal running mode.

**Note:** Indicators L3 and L4 have no function in 'Program mode'.

**Note:** Any adjustment that is not entered into the controller memory by pressing *STOP* (B3) will be ignored and the original value maintained.

## 2.2 Program Mode Setting Definitions

Indicator	Setting	Description
L1	Pressure set point P1	Pressure at which the compressor will unload.
L2	Oil temperature trip	Temperature at which the compressor will shut down and indicate a high oil temperature trip. (The oil temperature alarm is set automatically at 10°C below the trip)
L5	Pressure set point P2	Pressure at which the compressor will load.
L6	Model	Defines a number of fixed settings required by a particular compressor model. See 2.4 'Fixed Parameters'.
L7	Auto Restart delay	The time between power being restored after a power failure and the compressor automatically re-starting. (Set zero time to inhibit the Auto-restart function).
L8	Run-on time	The time which the compressor will run in the off-load state before the main motor stops and the compressor enters Standby mode.

## 2.3 Program Mode Settings

Indicator	Setting	Unit	Minimum	Maximum	Step	Default
L1	Pressure set point P1	Bar	5.1	14.0	0.1	7.5
L2	Oil temp trip	°C	90	120	1	115
L5	Pressure set point P2	Bar	5.0	13.9	0.1	7.0
L6	Model	Model	C105	C222	option	C215
L7	Auto restart delay	seconds	30/50	240	1	0
L8	Run-on time	minutes	3	15	1	3

**CAUTION:** The model option must be set to match the compressor data plate.

The P1 pressure set point must **not** be set above the maximum design pressure stated on the data plate.

**Note:** The minimum Auto restart delay time is set according to the normal blowdown time of the compressor model.

## 2.4 Fixed Parameters

The motor star/delta time and blowdown time are set automatically, depending on the compressor model programmed in the controller.

Parameter	Unit	Model					
		C105	C107	C111	C215	C218	C222
Star/Delta time	secs	2.2	2.6	3.0	3.6	4.0	4.4
Blowdown time	secs	15	15	15	20	20	20

**Note:** The blowdown time occurs when the drive motor stops. The compressor cannot be started during the blowdown time.

## 3. PRESSURE CALIBRATION MODE

### 3.1 Pressure Calibration Routine

The pressure calibration routine is used to calibrate the controller to the pressure transmitter to obtain an accurate pressure display reading when commissioning or re-commissioning the compressor and at each major service interval. The routine should also be used when renewing the controller or pressure transmitter.

1. Stop the compressor and isolate the compressor air delivery from the user's system.
2. Remove the air pipe from the pressure transmitter to establish a true zero pressure condition.

**Note:** Calibration will be affected if the air pipe is not removed before entering calibration mode.

3. Press and hold *PLUS* (B4), *MINUS* (B5) and *STOP* (B3) together.

4. After five seconds indicators L1 to L8 will flash four times to indicate that the controller is now in pressure calibration mode. Release *PLUS* (B4), *MINUS* (B5) and *STOP* (B3) when the indicators start to flash.
5. The display will show 0.0 Bar. If the pressure transmitter signal is outside of acceptable limits. The controller will automatically return to normal running mode and display a pressure transmitter fault.
6. Apply an accurately know pressure, above 5.5 Bar, to the pressure transmitter.
7. The display will not start to indicate a reading until the applied pressure is above 5.5 Bar.
8. Use *PLUS* (B4) and *MINUS* (B5) to increase or decrease the display reading.

**Note:** The controller will not allow the display to be adjusted outside of set maximum and minimum limits. The display will show four horizontal lines if the calibration limits are exceeded.

9. Press *STOP* (B3) when the pressure display matches the applied pressure. The display will return to normal running mode.
10. Press *RESET* (B6) at any time to abandon the calibration sequence and return to normal running mode.

## 4. CONTROL FUNCTION OPTIONS

### 4.1 Automatic Re-start

Automatic re-start will allow the compressor to start automatically after a break or failure in the mains power supply. When this facility is enabled the Remote start / Auto re-start indicator (L8) will be lit.

1. To enable Automatic re-start select an Automatic restart delay time of greater than zero seconds using the 'Program Mode'.
2. To disable Automatic restart select an automatic restart delay time of zero seconds.
3. When power is restored after a break or failure of the main supply power, the Remote start / Auto re-start indicator (L8) will flash for the programmed Auto re-start delay time. This provides a warning before the compressor re-starts. The compressor motor will automatically re-start and continue to run after the auto restart delay time expires.
4. The compressor will only automatically re-start if the compressor was in the On-load, Off-load or Standby mode when the break or failure in main supply power occurred.

#### 4.1.1 Automatic Restart Delay Time

The Auto restart delay time can be adjusted using the 'Program Mode'.

In multiple compressor installations, staggered restarting can be achieved by adjusting the delay time of each compressor differently.

Example - Four compressor installation:-

Compressor	Autorestart delay time
1	60 seconds
2	120 seconds
3	180 seconds
4	240 seconds

### 4.2 Remote Start/Stop Facility

#### 4.2.1 Remote Start

The remote start facility will enable the compressor to be started from a remote location.

1. When this option is selected, the Remote control/Auto re-start indicator (L8) will be lit and the *START* button (B2) on the compressor panel is disabled; all *STOP* functions are unaffected.
2. To enable the remote start facility connect a length of wire between terminal X2/1 and controller terminal X01, pin 7.
3. The compressor can be remotely started if remote start terminal X01, pin 8, is connected via a remote normally open button or other switching device, to terminal X2/1. The connection can be a pulse of at least 0.5 seconds or continuous.

#### 4.2.2 Remote Stop

The remote stop facility will enable the compressor to be stopped from a remote location.

1. The remote stop is active at all times, regardless of the remote start facility being enabled.
2. The compressor can be stopped remotely by disconnecting the wire link between terminals X2/1 and X2/2 via a remote normally closed button or other switching device.

### 4.3 Remote Load/Unload

The remote load/unload facility enables the compressor to be pressure controlled by a remote pressure switch, pressure control system or cascade panel.

1. To enable the remote Load/Unload facility connect a length of wire between terminal X2/1 and controller terminal X01, pin 5.

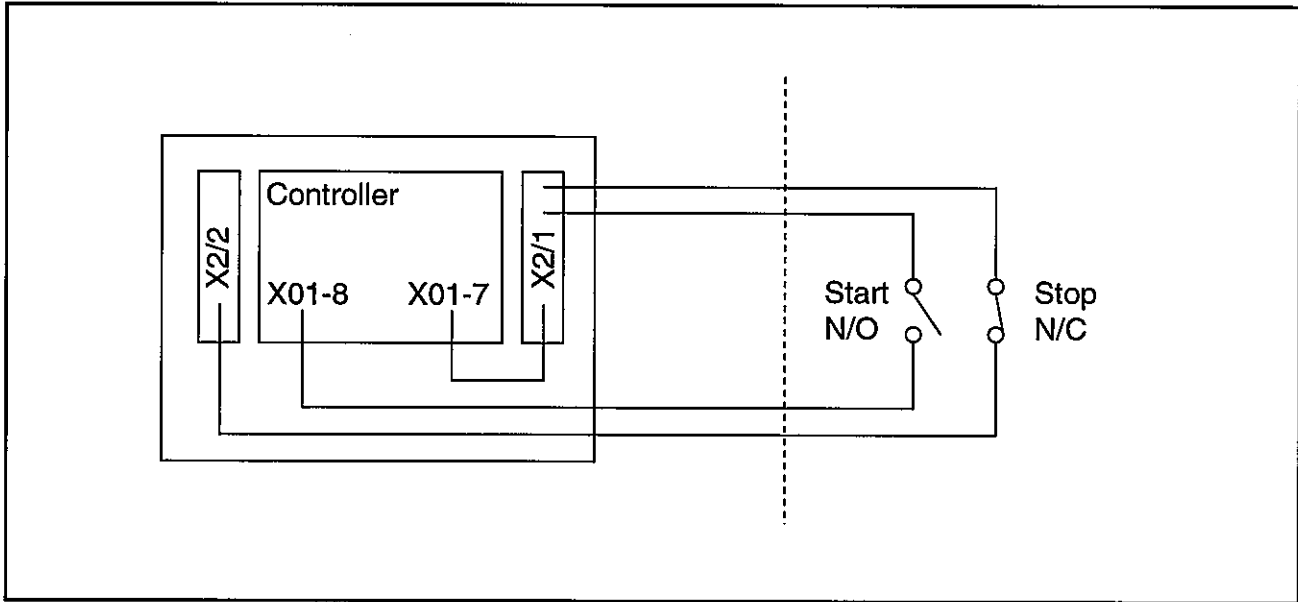


FIG. 4.2 REMOTE start/STOP

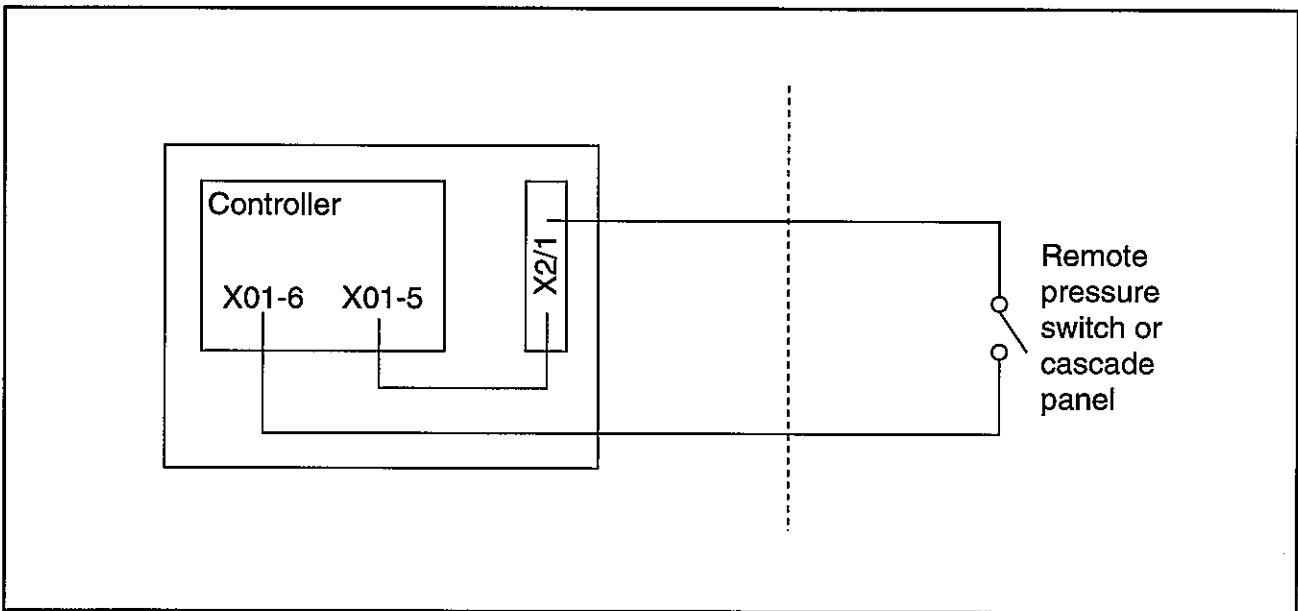


FIG. 4.3 REMOTE LOAD/UNLOAD

2. When this option is selected the compressor will load when terminal X01, pin 6 is connected, via a remote pressure switch, cascade control panel or other switching device, to terminal X2/1.
3. The compressor will unload when the connection between X01, pin 6 and X2/1 is broken.

#### 4.4 Remote Group Fault Output

##### 4.4.1 Group Fault Relay

The control card is fitted with a group fault relay, the relay contacts being available for switching remote facilities. The relay contacts are rated for a maximum of 250V ac at 5A and are connected to controller terminal X08, pins 9 and 10.

##### 4.4.2 Group Fault Relay Operation

When power is switched ON, and no alarm or trip is detected, the group fault relay will energise and the contacts will close circuit. If an alarm or fault is detected or a power failure occurs, the relay will de-energise and the contacts will open circuit. The relay will energise again when the controller is reset and no further alarm or trip condition exists.

##### 4.4.3 Group Fault Relay - Example

If the output is required for switching a remote fault lamp or an audible alarm, for example, an additional relay 98475-71 and base 98475-72 will be required as shown in the diagram below:-

**Note:** If the compressor has been out of operation for a prolonged period it is advisable to carry out the full commissioning procedure before starting.

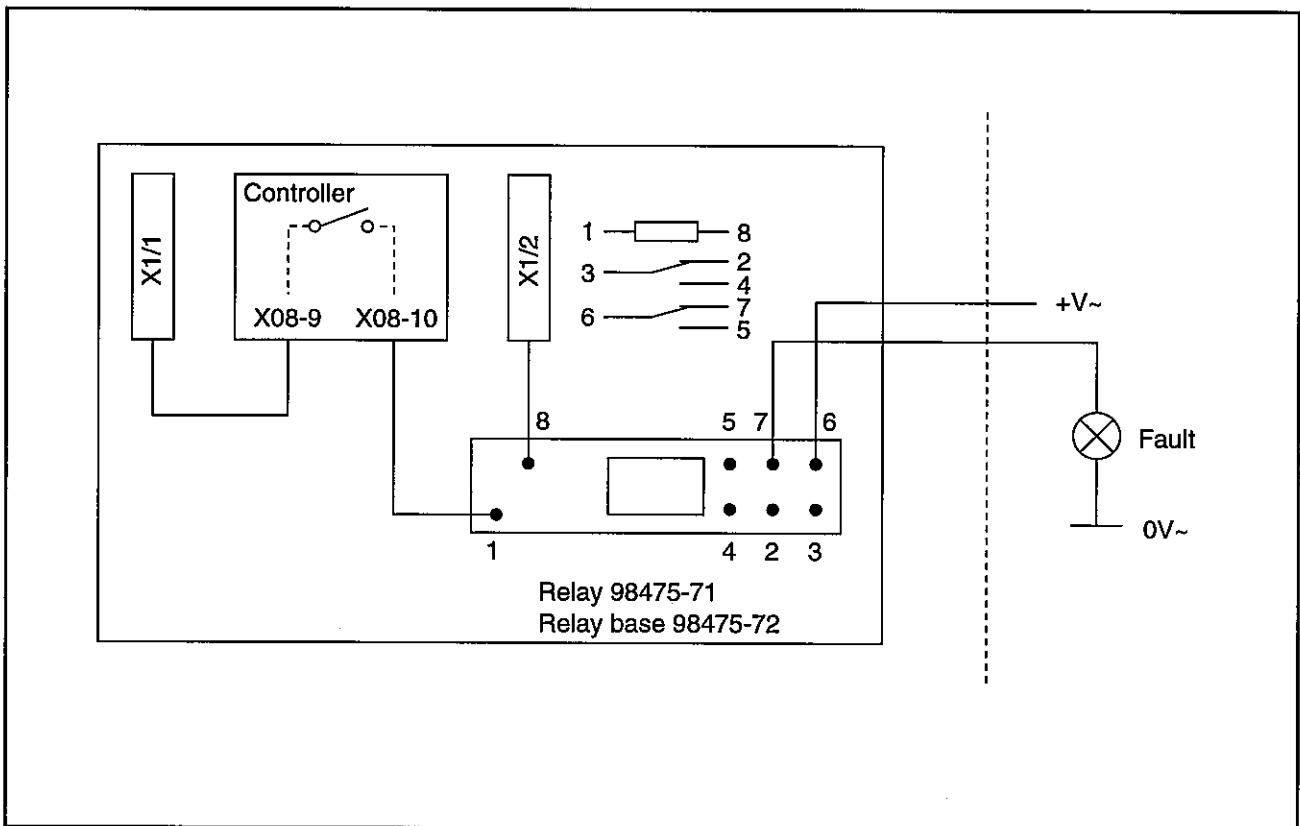






FIG. 4.4 GROUP FAULT RELAY – EXAMPLE

## FAULT FINDING

In operation the compressor is protected by circuits which are triggered when a fault arises and either cause the compressor to shut down or indicate that a servicing action is required.

  <b style="margin: 0 20px;">WARNING</b>  
<ul style="list-style-type: none"> <li style="display: inline-block; width: 45%; vertical-align: top;"> <p>● Refer to the safety procedures before carrying out any fault finding investigation on the compressor unit.</p> </li> <li style="display: inline-block; width: 45%; vertical-align: top;"> <p>● Lethal voltages are used in this equipment. Use extreme caution when carrying out electrical checks. Isolate the power supply before starting any maintenance work.</p> </li> </ul>

### 1. FAULT INDICATIONS

#### 1.1 Trip Fault Indications

Display	Meaning
L1 to L8 Flashing Quickly	Emergency Stop
L1 Flashing Quickly	Excess Pressure
L1 Flashing Quickly, Pressure Display shows (----)	Pressure Sensor Failure
L2 Flashing Quickly	Excess Temperature
L2 Flashing Quickly, Temperature display shows (----)	Temperature sensor failure
L6 Flashing Quickly	Drive Motor Fault
Display shows (≡ )	Power Failure

## 1.2 Alarm Fault Indications

Display	Meaning
L2 Flashing Slowly	High Temperature
L5 Flashing Slowly	Change air filter

## 2. SHUTDOWN FAULTS

Fault	Possible Cause	Action Required
Emergency Stop	(1) Emergency Stop Switch operated.	(1) Establish reason and rectify. Turn Emergency Stop switch to release latch and Press <i>RESET</i> .
Excess Pressure	(1) Compressor failed to unload.	(1) (a) Check air intake valve operation and diaphragm. (b) Check operation of load solenoid valve.
Pressure Sensor Failure	(1) Wire Connections. (2) Sensor failure.	(1) Check all pressure sensor circuit wire connections. (2) Renew sensor.
Excess Temperature	(1) Insufficient cooling air flow.  (2) High ambient Temperature. (3) Oil cooler bypass valve.  (4) Low oil level.  (5) Incorrect oil grade.	(1) Check all panels secure. Check fan blades. Clean pre-filter. Clean coolers. (2) Check room ventilation. (3) Check for correct operation faulty. (4) Check for leaks and rectify. Top up oil to correct level. (5) Check oil grade, drain and flush oil system and service oil filter and oil separator elements.
Temperature sensor failure	(1) Wire Connections. (2) Sensor failure.	(1) Check all temperature sensor circuit wire connections. (2) Renew sensor.

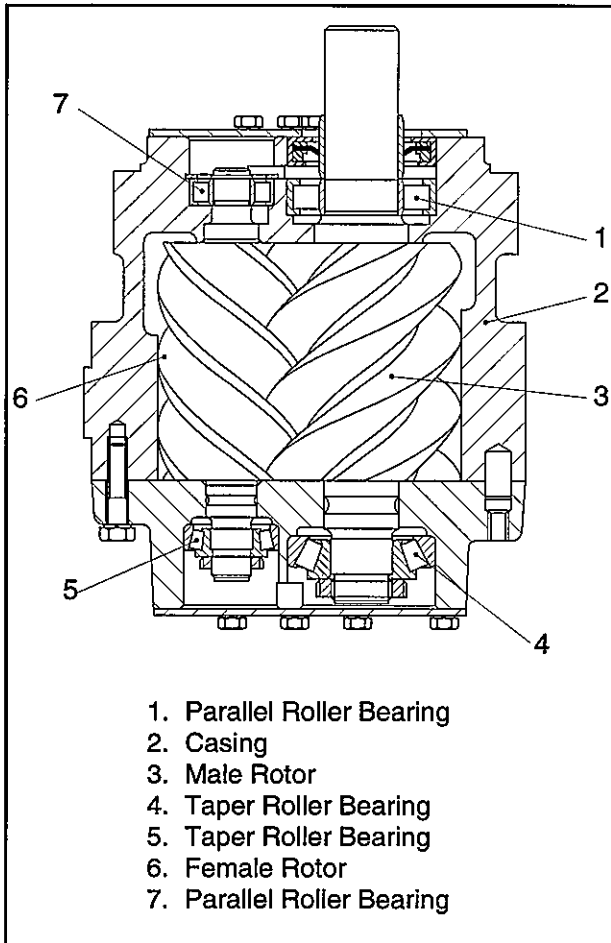
<b>Fault</b>	<b>Possible Cause</b>	<b>Action Required</b>
High Oil Carry Over	(1) Separator element. (2) Oil Drain Valve  (3) Scavenge solenoid	(1) Fit new element. (2) Check valve closed. Replace valve and seal if necessary. (3) Check solenoid timer; increase open time if necessary.
Drive Motor Fault	(1) Overload relay incorrectly set. (2) Insufficient cooling air flow.  (3) High ambient temperature. (4) Low voltage/high current.	(1) Check setting and reset. (2) Check all panels secure. Check fan blades. Clean pre-filter. Clean coolers. (3) Check room ventilation. (4) Check main power supply.

### 3. ALARM FAULTS

<b>Fault</b>	<b>Possible Cause</b>	<b>Action Required</b>
High Temperature	(1) Insufficient cooling air flow.  (2) High ambient Temperature (3) Oil cooler bypass valve faulty. (4) Low oil level. (5) Incorrect oil grade.	(1) Check all panels secure. Check fan blades. Clean pre-filter. Clean coolers. (2) Check room ventilation. (3) Check for correct operation. (4) Check for leaks and rectify. Top up oil to correct level. (5) Check oil grade, drain and flush oil system and service oil filter and oil separator elements.
Change air filter	(1) Intake air filter blocked.	(1) Renew air filter element.

## COMPONENTS

### 1. AIR-END (Cyclon 1 or 2)



**FIG. 5.1 AIR-END - GENERAL ARRANGEMENT**

#### 1.1 Description

The air is compressed in a single-stage, positive displacement, oil injected rotary screw air-end. The air-end is of the Cyclon type and comprises an intermeshing pair of helical screw rotors, male and female, mounted horizontally within an enclosed casing with drive being applied to the male rotor.

The male rotor in the Cyclon air-end is larger in diameter than the female rotor and has four lobes which mesh with five flutes on the female rotor. The rotors are asymmetric in profile to reduce blowback between the lobes on the compression cycle to a minimum, thus maximising overall sealing and efficiency.

The rotors are fitted with bearings at each end to provide radial and axial support, maintain adequate shaft stiffness and to give minimum clearance and low leakage between the rotor tip diameter and the casing.

At the delivery end the male and female rotors are fitted with a single taper roller bearing. These bearings provide axial and radial support of both rotors and control the very fine end clearances between the rotors and the casing.

Heavy duty parallel roller bearings are fitted to both rotors at the inlet end to provide radial support and to sustain the drive load of the male rotor.

#### 1.2 Operation

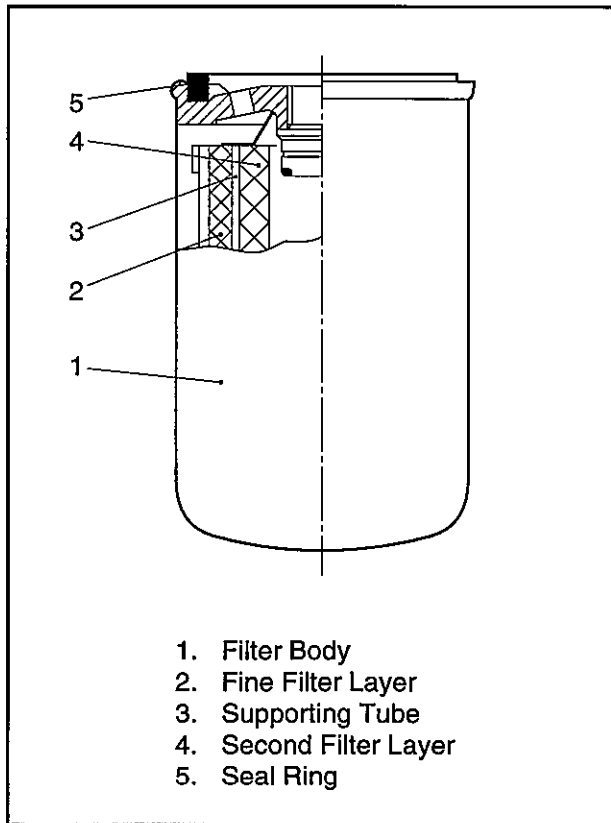
Compression takes place between the lobes on the male rotor, the flutes on the female rotor and the air-end casing. When the compressor is running the helical engagement of the rotors provides the drive for the female rotor.

As the rotors turn, air at atmospheric pressure enters the inlet port and fills the space between the lobes of the male rotor and the flutes of the female rotor. Oil is injected into the air at this point and the trapped air/oil mixture is progressively compressed by the reduction in space created by continuous rotation of the rotors within the air-end casing.

Continued rotor rotation increases the pressure and temperature of the air/oil mixture which passes from the air-end discharge pipe into the oil separator where primary separation takes place by centrifugal force. Most of the oil is separated at this stage and drops to the bottom of the vessel.

Oil is continually injected into the low pressure region of the air-end and mixes with the air during the compression process. The oil carries out three functions; lubrication, cooling and sealing. The oil lubricates the rotors and bearings, acts as a coolant by absorbing the heat of compression and seals the fine clearances that exist between the rotors and between the rotors and casing. The compressed air/oil mixture is discharged from the air-end and into the reclaiming system where the oil is separated and returned to the system.

## 2. SEPARATOR VESSEL AND SEPARATOR FILTER ELEMENT



**FIG. 5.2 SEPARATOR ELEMENT**

### 2.1 Description

Primary separation of oil from the air/oil mixture takes place in the separator vessel which is positioned between the air-end and aftercooler.

The separator comprises a steel pressure vessel with a welded cover which forms a platform for the air-end mounting plate assembly. The bottom of the separator vessel is welded to a base which also supports the drive motor. Anti-vibration mountings are used to attach the base to the baseframe.

The cover carries the scavenge oil pipe, connections for the air and oil pipework and a safety relief valve. An oil filler pipe and oil level sightglass assembly are fitted to the wall of the separator vessel.

The separator vessel operates in conjunction with a separator filter element where final separation takes place. The separator element is located on the manifold block and is fabricated from layers of micro fine glass fibre, supported by tubes and protected externally by a perforated steel sheath. A scavenge pipe, located on the underside of the manifold block, passes through the centre of the element which screws into position against a machined face.

### 2.2 Operation

The air/oil mixture passes from the air-end discharge pipe into the oil separator vessel where primary separation takes place by centrifugal force. Most of the oil is separated at this stage and drops to the bottom of the vessel.

The remaining air/oil mixture then passes through the separator filter element where final separation takes place. The separator element functions with the principle of coalescence. The micro glass fibre layers separate the oil droplets which collect in the bottom of the filter and scavenged back into the air-end through a small diameter pipe. The scavenge cycle is regulated by a solenoid valve controlled by a timer.

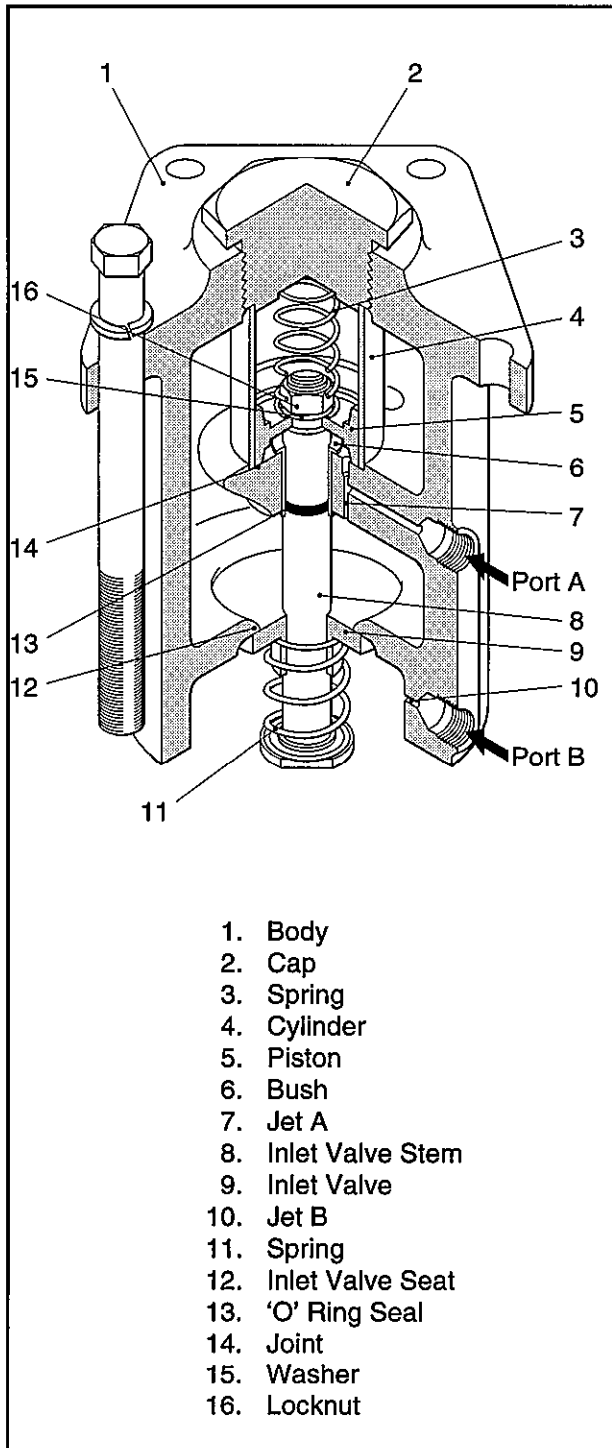
The filtered air then passes from the oil separation element by way of the minimum pressure/ non-return valve. Provided the air pressure at this stage is above 4 to 4.5 bar the air passes through the aftercooler where it is cooled before passing to the delivery outlet.

If the air pressure in the primary separator vessel falls below 4 to 4.5 bar the minimum pressure valve will close. The valve also incorporates a non-return valve which operates to prevent delivery air passing back into the separator when the compressor is running off-load.

Oil from the bottom of the separator flows under pressure to the oil cooler and during normal running the oil passes through the cooler to maintain the correct temperature. A thermostatic bypass valve is installed in the inlet manifold of the oil cooler.

### 3. SUCTION REGULATOR

The suction regulator controls the flow of air entering the air-end. It is operated by a combination of pneumatic and electrical circuits used in the regulation system.



**FIG. 5.3 SUCTION REGULATOR**

#### 3.1 Description

The main parts of the suction regulator are the regulator body, inlet valve assembly and piston assembly.

The regulator body (1) is mounted to the top of the air-end and is connected to the air intake filter by a flexible sleeve secured with clips.

Two ports A and B in the suction regulator body provide an air connection between the oil separator and the suction regulator.

The inlet valve (9) is free to move on the inlet valve stem (8) and is held against the inlet valve seat (12) by a return spring (11). The inlet valve assembly consisting of the inlet valve and stem is supported by a bush (6) which is located within the body of the suction regulator. An 'O' ring seal (13) fitted to the inlet valve stem prevents pressure leakage past the stem.

A piston (5) is fitted to the top of the valve stem and secured in place by a locknut (16) and washer (15). The piston is free to move inside a cylinder (4) and is held against the bottom of the cylinder by a return spring (3). A joint (14) is fitted between the cylinder and the regulator body. The piston, cylinder and return spring assembly is held in place by a cap (2) which is screwed into the top of the regulator body.

Air from the underside of the piston is exhausted to atmosphere via jet A (7). When the compressor is running off load air is directed from the separator and through jet B (10).

#### 3.2 Operation

The control system is designed to load and unload the compressor by opening or closing a pneumatically operated air inlet valve in the suction regulator in response to a signal provided by the electronic control system. The electronic controller uses a pressure transducer to measure air delivery pressure and provides a load/unload signal to the unloader solenoid valve.

The suction regulator incorporates a bleed and a blowdown system for the oil separator together with an off-load noise reduction system.

### 3.2.1 Compressor Stopped; Power On

The suction regulator inlet valve (9) is held closed by a return spring (11) and another spring (3) holds the piston (5) in position at the bottom of the cylinder. The unloader solenoid is de-energised with the valve in the open position. This provides an air connection between the oil separator, port A of the suction regulator and through a non-return valve to port B. The minimum pressure /non-return valve is closed, isolating the separator from the user's air system.

### 3.2.2 Compressor Starting

The compressor will start providing the delivery pressure is below the lower set point P2. The depression created by the turning rotors causes a partial vacuum at the compressor intake which lifts the inlet valve (9) off its seat (12) against the light load of the spring (11). This allows air to be drawn through the air-end to pressurise the separator. The minimum pressure/non-return valve remains closed.

Air passes from the separator and through the open unloader solenoid valve to the underside of the piston (5) via port A. At 0.2 - 0.4 bar the pressure will exceed the force of the spring (3) causing the piston and stem (8) to lift, closing the inlet valve.

To minimise the starting current the motor control circuit ensures that the motor is run up to speed in Star connection. After a short time delay the control circuit switches the motor to Delta and after a further short delay the unloader solenoid valve is energised to close.

When the unloader solenoid valve closes, air from the underside of the piston is exhausted to atmosphere via jet A (7). The piston then moves down under the force of the spring allowing the inlet valve to open and the compressor to run on-load.

### 3.2.3 Compressor Running

As the air pressure in the separator rises quickly to between 4 and 4.5 bar the minimum pressure valve opens and delivery air passes into the user's system. When the pressure reaches the upper set point P1 the controller de-energises the unloader solenoid and the valve opens. This allows air from the separator vessel to pass via port A to the underside of the piston which lifts against the force of the spring and closes the inlet valve, causing the compressor to run off-load.

At this point air is exhausted to atmosphere through jet A (7), reducing the pressure in the separator to approximately 2.2 bar whilst running off-load. The non-return valve closes to prevent air from the system flowing back to the separator.

To reduce noise when running off-load, air is directed from the separator and through jet B (10) to reduce the pressure ratio across the air-end and the vacuum in the compressor inlet.

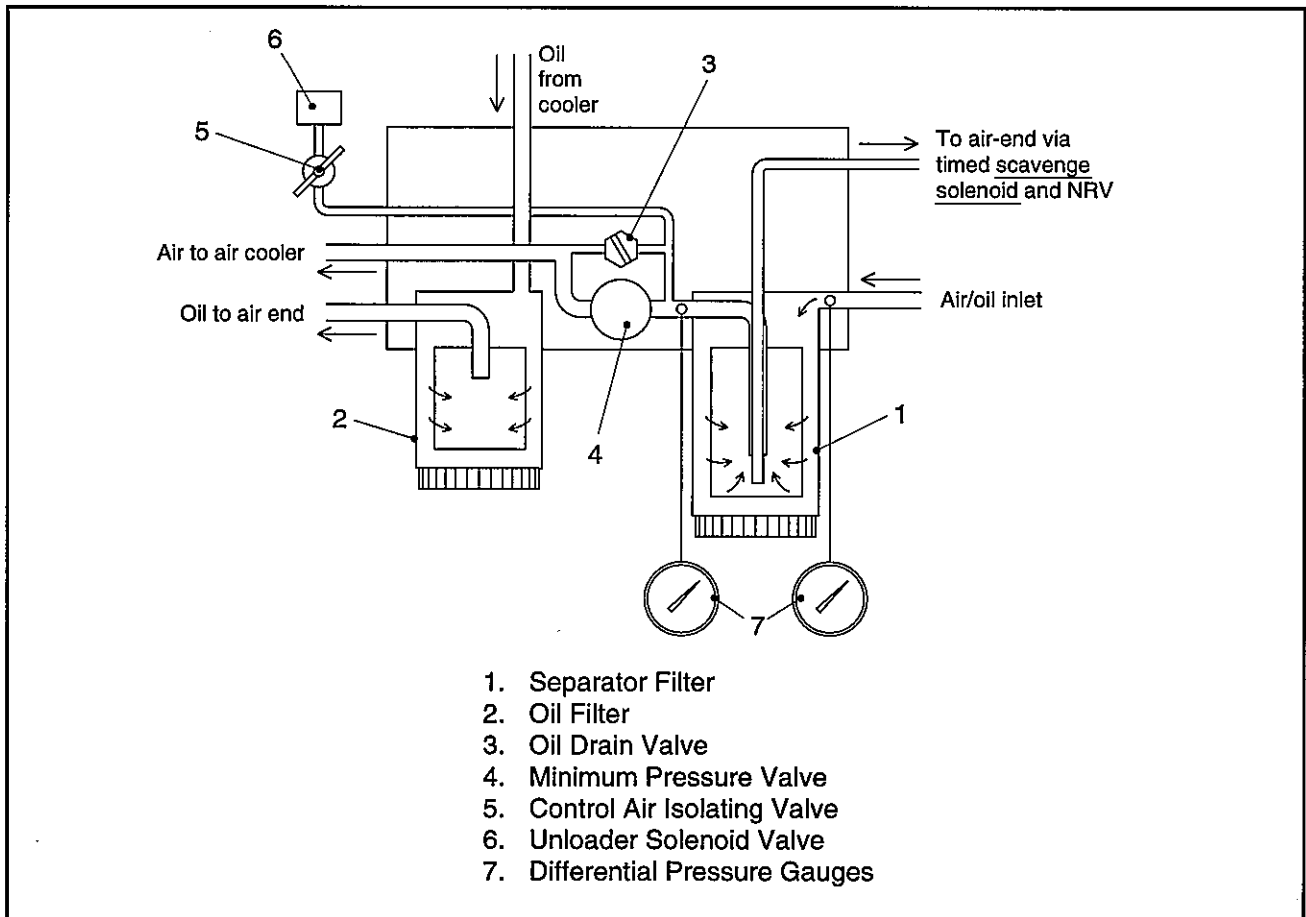
When the controller switches the compressor to run off-load, a run-on time sequence is activated. This allows the compressor to run for a pre-set period of time off-load. If this time elapses before the pressure in the system has fallen to the lower set point, the controller de-energises the drive motor and the compressor stops.

### 3.2.4 Stopping the Compressor

The compressor may be stopped through manual operation of the stop switch, emergency stop or automatically by the controller due to low air demand. In each case the unloader solenoid valve is de-energised, and air is directed from the oil separator into the suction regulator to unload the compressor.

The inlet valve returns to its seat and prevents the air/oil mixture from blowing back through the intake. The non-return valve in the line prevents the air/oil mixture from blowing back through jet B (10). The air in the separator is exhausted to atmosphere via the unloader solenoid valve through jet A (7).

#### 4. MANIFOLD BLOCK



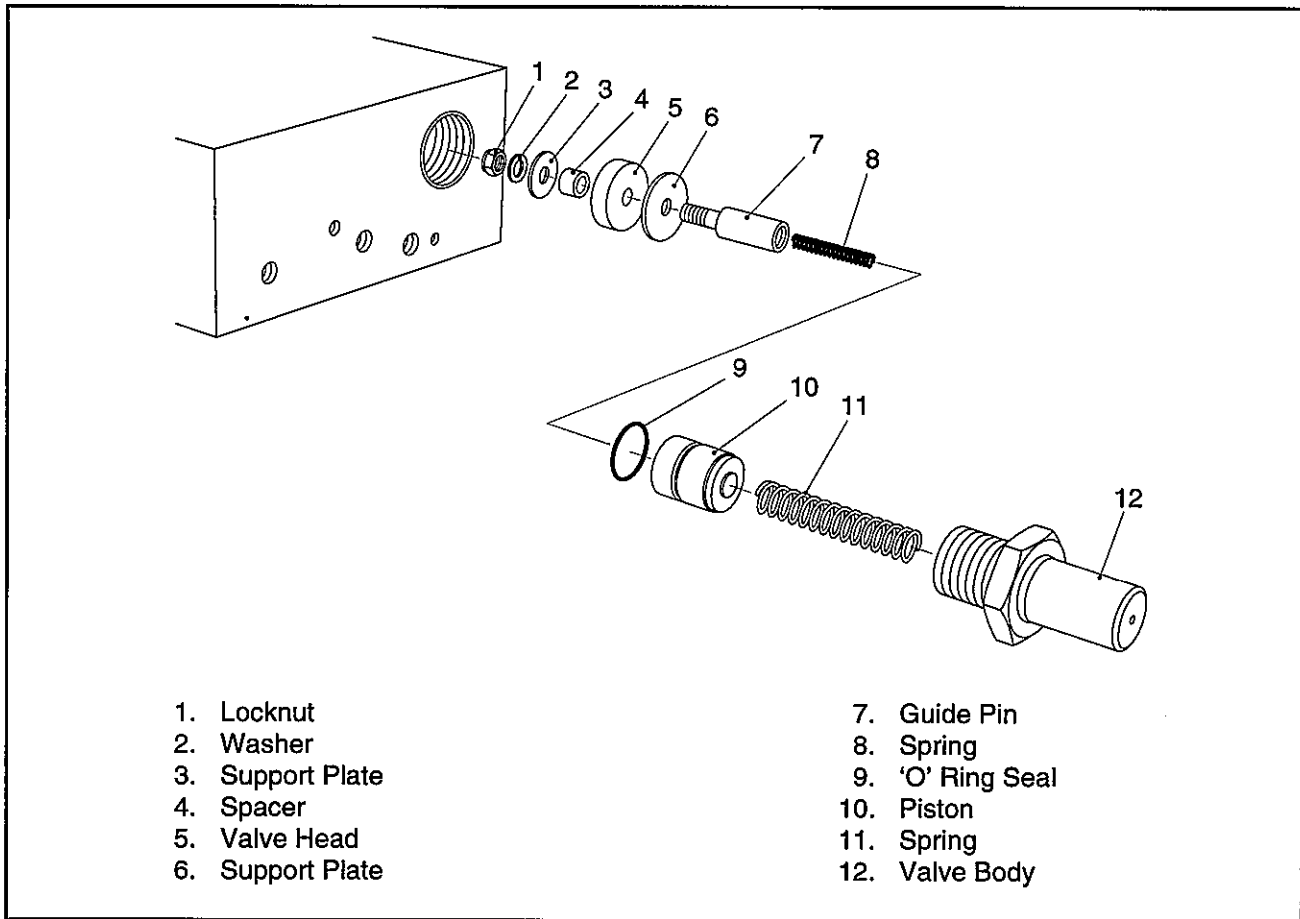
**FIG. 5.4 MANIFOLD BLOCK**

An aluminium manifold block is screwed to the bulkhead panel to provide ease of maintenance for the servicable components.

The manifold block is ported and machined to provide a housing for the separator filter and scavenge pipe, oil filter, minimum pressure valve, oil drain valve and differential pressure gauges for the separator filter element.

Pipework connections are provided as follows:- air/oil inlet and air outlet from the separator element, oil inlet and outlet from the oil filter, unloader solenoid valve and scavenge return to the air-end via a solenoid.

## 5. MINIMUM PRESSURE VALVE



**FIG. 5.5 MINIMUM PRESSURE VALVE – MODELS 105, 107 AND 111**

### 5.1 Description – Models 105, 107 and 111

The minimum pressure valve fits inside the manifold block and performs the following main functions:

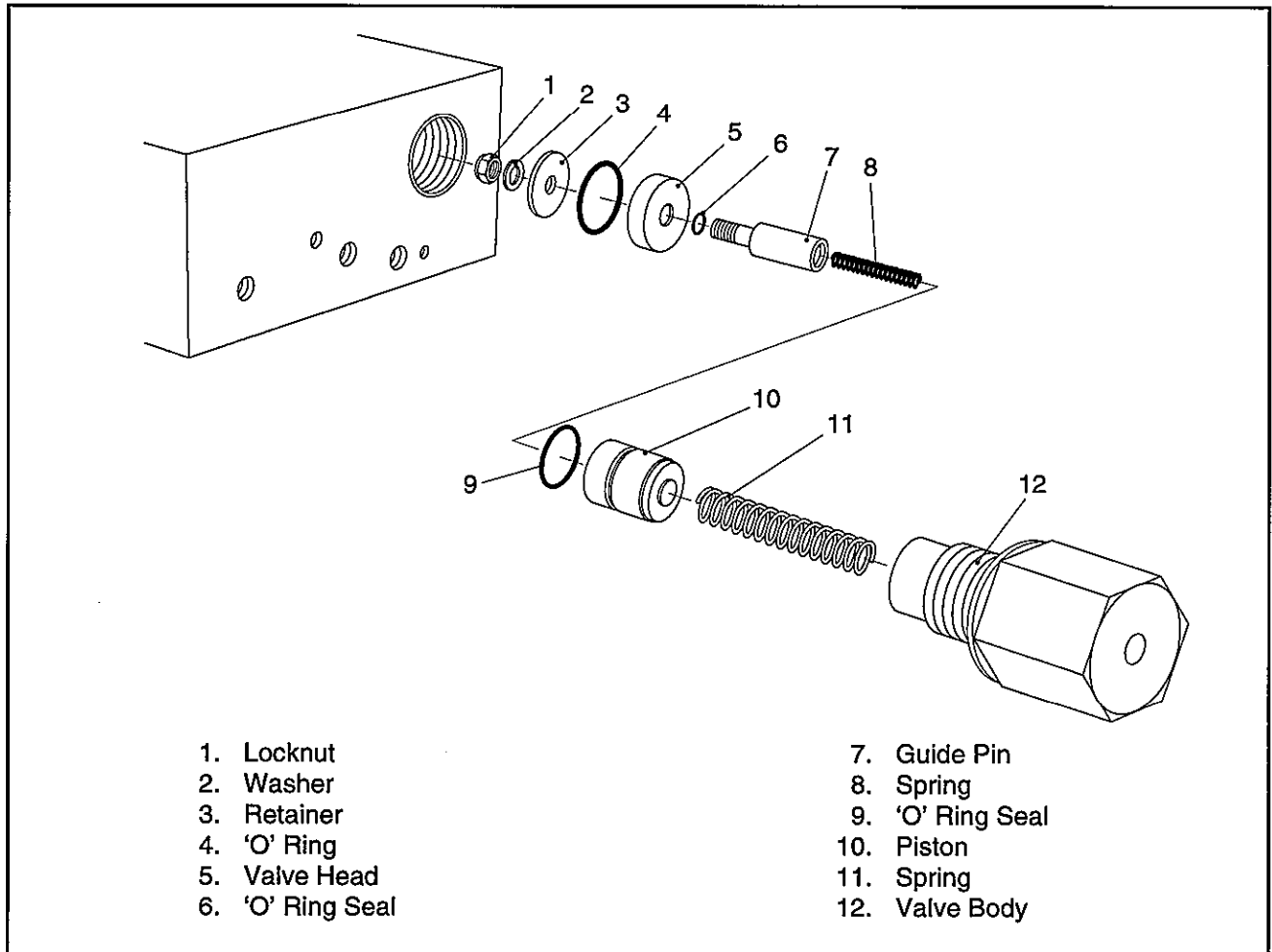
1. It ensures a rapid pressure build-up in the reclaimer during initial start-up. The minimum pressure valve is held closed until the pressure in the reclaimer reaches 4 bar.
2. It prevents high velocity, low pressure air carrying over excessive amounts of oil into the delivery air pipe during start-up.
3. The minimum pressure valve also incorporates a non-return valve. This prevents pressurised air in the user's pipework passing back into the reclaimer when the compressor unit stops or runs off-load.

The minimum pressure valve consists of a valve body (12), valve assembly, and piston (10).

The valve assembly comprises a guide pin (7), valve head (5), spacer (4) and two support plates (3, 6) secured by a washer (2) and a locknut (1). The guide pin houses a spring (8) and is located inside the piston.

The valve head is seated against a face machined in the manifold block. The piston moves inside the bore of the valve body and a spring (11) forces the piston against the rear face of the valve assembly. An 'O' ring seal (9) fitted to the outside of the piston prevents any pressure leakage past the piston.

The piston and valve assembly move to control the flow of air through the valve.



**FIG. 5.6 MINIMUM PRESSURE VALVE – MODELS 215, 218 AND 222**

### 5.2 Description – Models 215, 218 and 222

The minimum pressure valve fits inside the manifold block and performs the following main functions:

1. It ensures a rapid pressure build-up in the reclaimer during initial start-up. The minimum pressure valve is held closed until the pressure in the reclaimer reaches 4 bar.
2. It prevents high velocity, low pressure air carrying over excessive amounts of oil into the delivery air pipe during start-up.
3. The minimum pressure valve also incorporates a non-return valve. This prevents pressurised air in the user's pipework passing back into the reclaimer when the compressor unit stops or runs off-load.

The minimum pressure valve consists of a valve body (12), valve assembly, and piston (10).

The valve assembly comprises a guide pin (7), valve head (5), retainer (4) and two 'O' ring seals (3, 6) secured by a washer (2) and a locknut (1). The guide pin houses a spring (8) and is located inside the piston.

The valve head is seated against a face machined in the manifold block. The piston moves inside the bore of the valve body and a spring (11) forces the piston against the rear face of the valve assembly. An 'O' ring seal (9) fitted to the outside of the piston prevents any pressure leakage past the piston.

The piston and valve assembly move to control the flow of air through the valve.

### 5.3 Operation – All Models

When the compressor starts, the minimum pressure valve is held in the closed position by the effect of a spring against the top of the piston and by the face of the piston holding the valve assembly against the seat. The valve remains closed until the pressure in the separator vessel reaches a set minimum pressure (4 bar). When the pressure in the separator vessel overcomes the force exerted by the two springs, the valve assembly and piston move up allowing full air flow past the open valve, through the outlet port and into the main delivery pipe to the aftercooler.

When the compressor off-loads the flow of air ceases between the separator vessel and the user's pipework. Pressure in the compressor system acts to hold the minimum pressure valve piston in the raised position against the effect of the spring and at the same time the valve spring closes the non-return valve onto its seat.

When the compressor reverts to on-load running, the valve assembly will stay closed against the seat until the pressure in the separator vessel exceeds the pressure in the user's pipework. The plunger will not return to close the outlet until the pressure in the user's pipework falls below the force of the springs.

## 6. OIL & AFTERCOOLERS

### 6.1 Description

The oil cooler cools the oil from the separator vessel before it returns to the air-end via the oil filter. The cooler comprises a two pass matrix, connected to an inlet and outlet header, mounted horizontally at the top of the unit. A thermostatic bypass valve is installed in the inlet header.

The aftercooler cools the discharge air before it passes into the main distribution pipework. The cooler is mounted vertically and comprises a bank of finned tubes, connected to inlet and discharge headers, attached to mounting points on the frame adjacent to the air intake panel.

A connection for the inlet air is provided in the upper header while a similar discharge connection is fitted in the lower header.

The cooling fan is mounted on the motor shaft in front of the drive pulley.

### 6.2 Operation

Compressed air from the reclaiming enters the upper header of the aftercooler, passes downwards through the finned tubes to the lower header and out into the user's pipework. Separated moisture passes to the automatic condensate drain and is expelled via the baseframe connection and drain pipe.

Oil from the bottom of the separator vessel flows under pressure to the oil cooler (10) and during normal running the oil passes through the cooler to maintain the correct temperature. A thermostatic bypass valve (14) is installed in the inlet manifold of the oil cooler.

When the compressor is started, the cold oil in the system bypasses the cooler and flows through the oil filter (8) directly to the air-end. As the oil and air mixture is compressed by the rotors in the air-end, the temperature of the oil increases.

When the oil has reached its normal operating temperature the bypass valve closes and the oil is directed through the oil cooler. The cooled oil then flows to the oil filter where it is cleaned before entering the air-end.

The cooling fan draws air through the unit via the aftercooler and discharging through the oil cooler to a vent in the top of the unit.

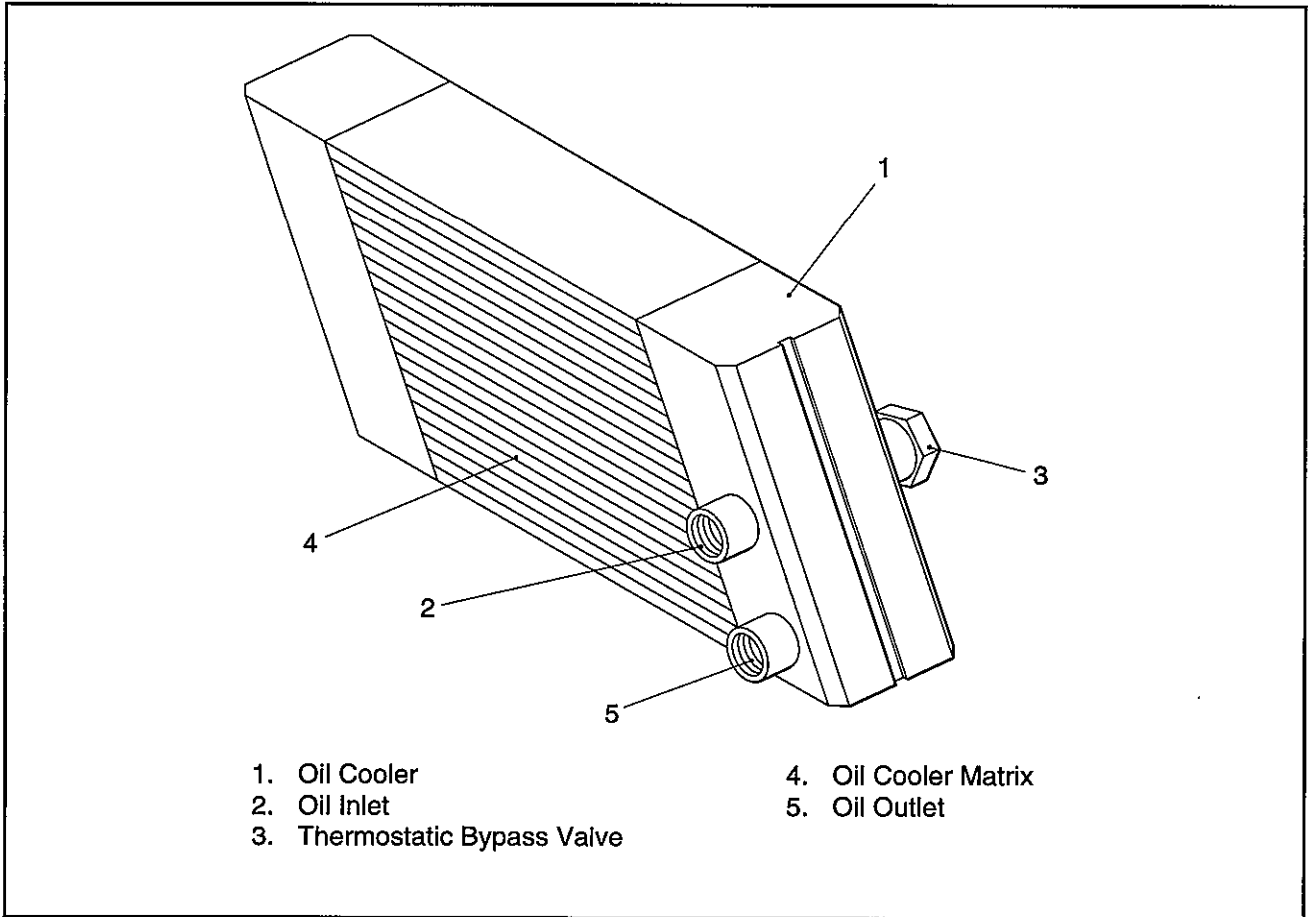
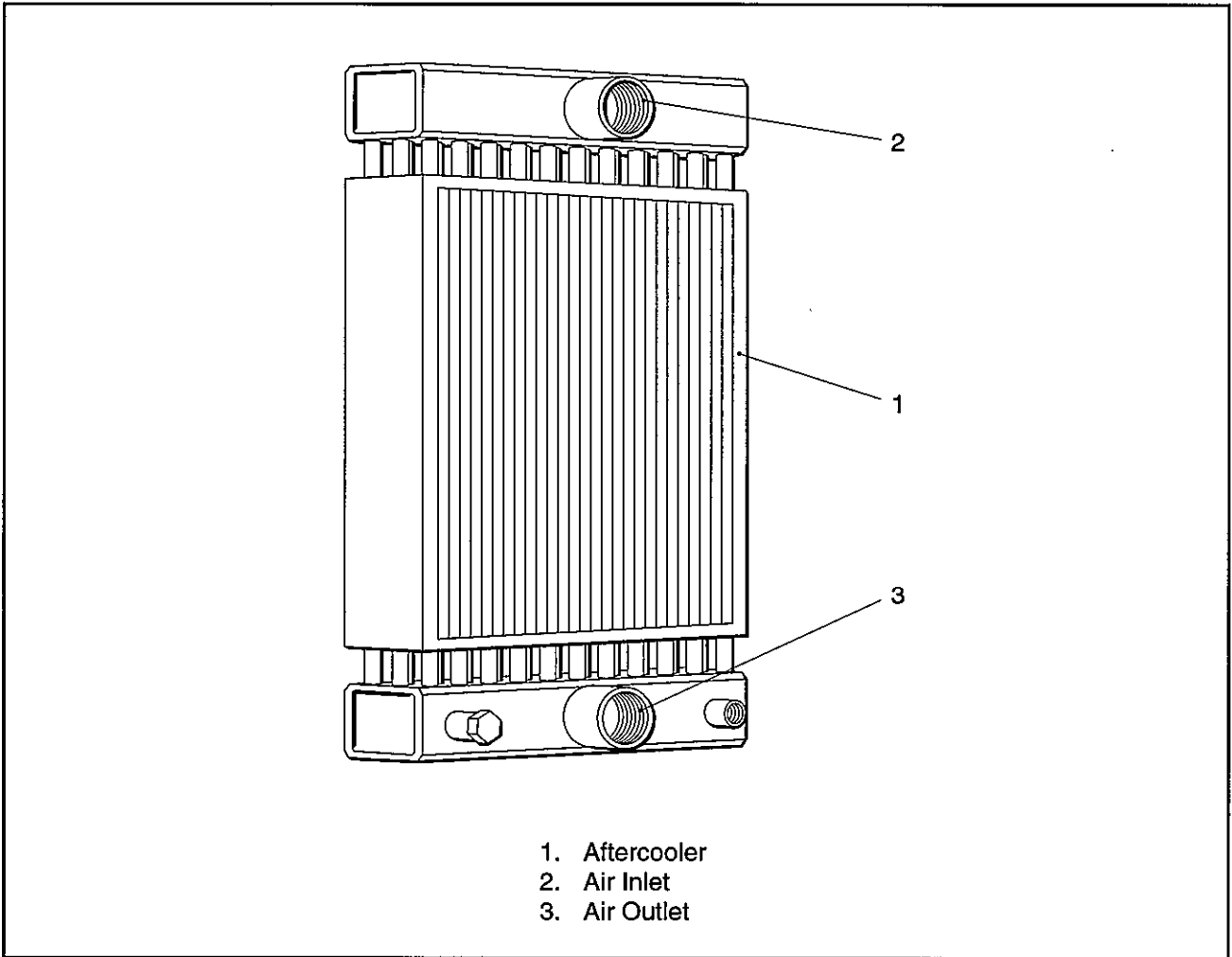
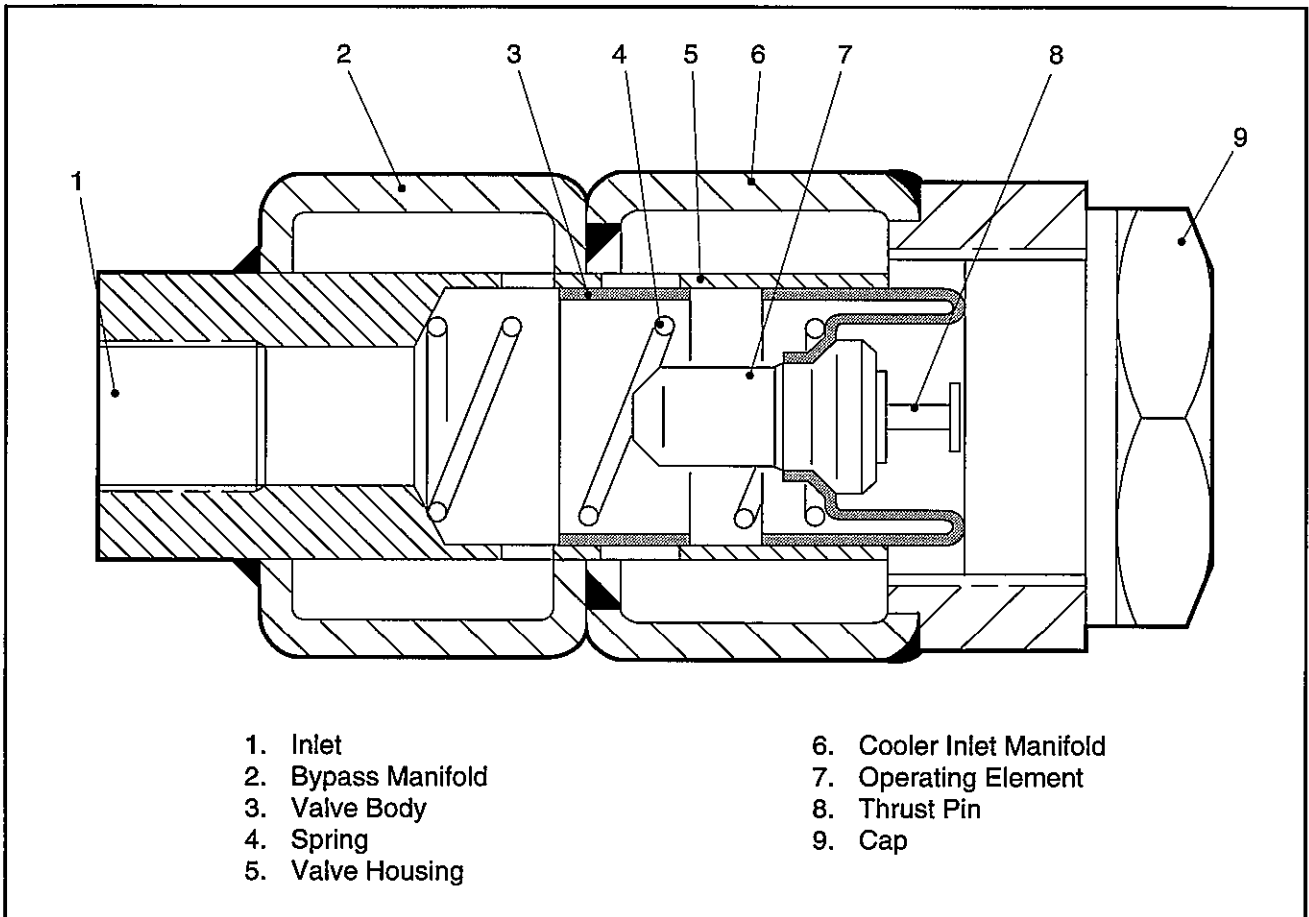


FIG. 5.7 OIL COOLER



**FIG. 5.8 AFTERCOOLER**

## 7. THERMOSTATIC BYPASS VALVE



**FIG. 5.9 THERMOSTATIC BYPASS VALVE**

### 7.1 Description

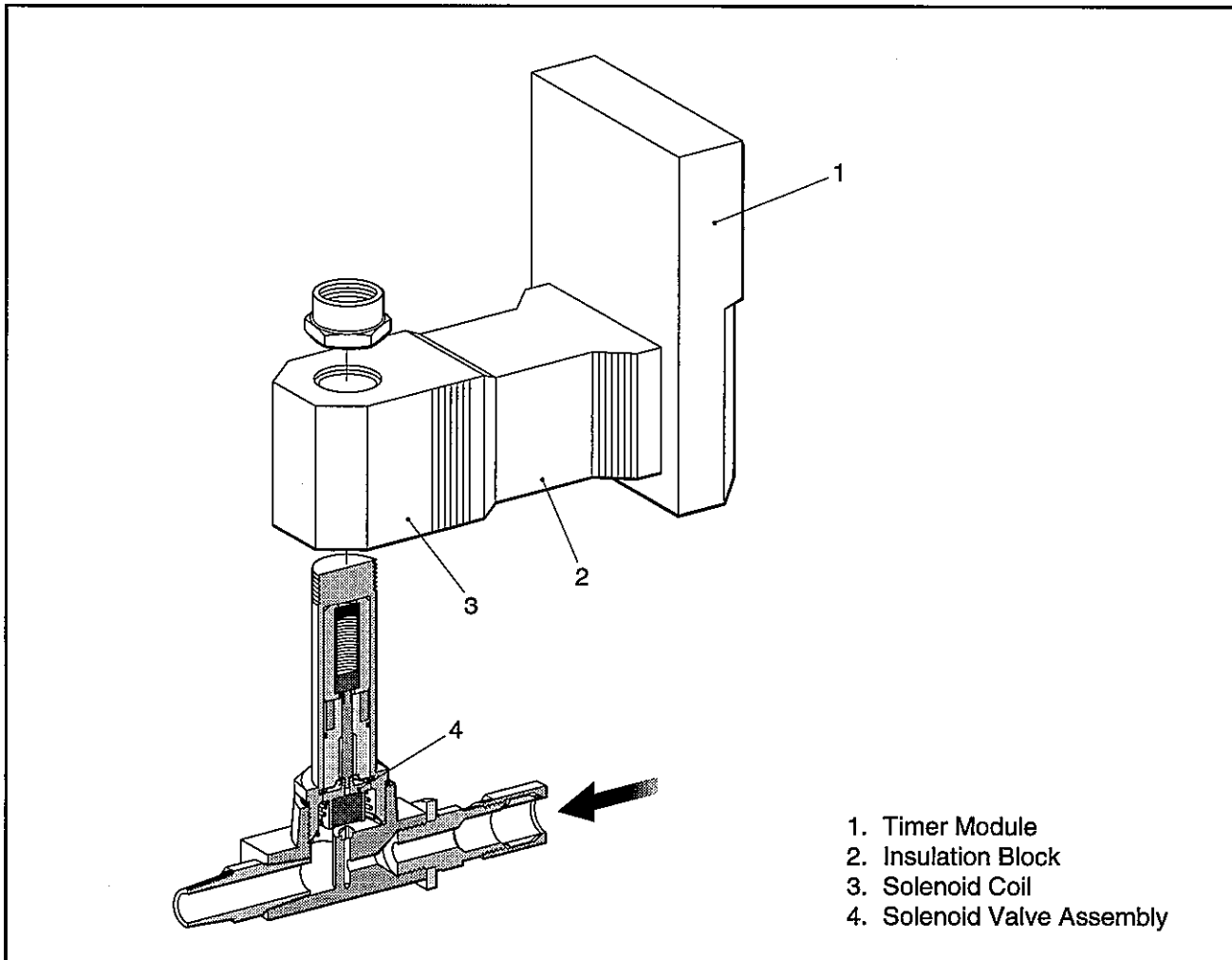
The oil cooler is equipped with a thermostatic bypass valve which allows the oil in the system to reach operating temperature rapidly. The valve is installed in the inlet connection of the cooler header and is held closed when the oil is cold. The cold oil bypasses the cooler tube block until the operating temperature (70°C) is reached.

The thermostatic bypass valve consists of the operating element (7), thrust pin (8), valve housing (5) and spring (4). The operating element is a sealed capsule containing wax into which is inserted the thrust pin. The valve body (3) is attached to the operating element. When the oil is cold the valve is held in position by the spring (4). Oil enters the valve through the inlet (1) and leaves by way of the bypass manifold (2).

### 7.2 Operation

When the temperature of the oil increases to the set point of the thermostat, the expansion of the melting wax in the capsule forces the thrust pin out of the capsule and moves the valve body (3) to close the outlet to the bypass manifold (2) and open the inlet to the cooler manifold (6). The hot oil is then directed through the cooler tube block. A cap (9), installed in the cooler header, holds the valve in position and allows access for servicing purposes.

## 8. SCAVENGE SOLENOID VALVE AND TIMER MODULE



**FIG. 5.10 SCAVENGE SOLENOID VALVE AND TIMER MODULE**

A solenoid valve and timer unit are fitted in the scavenge return line to control the flow of oil from the separator element. The module is connected directly to the 24V ac supply allowing the solenoid to cycle continuously when power is applied to the compressor, regardless of the operational mode. The 24V ac supply to the timer unit is only interrupted when the emergency stop button is activated.

The scavenge solenoid valve is controlled by a timer unit which connects directly to the solenoid. The timer switches power to the solenoid coil **off** for five seconds every forty seconds.

## 9. UNLOADER SOLENOID VALVE

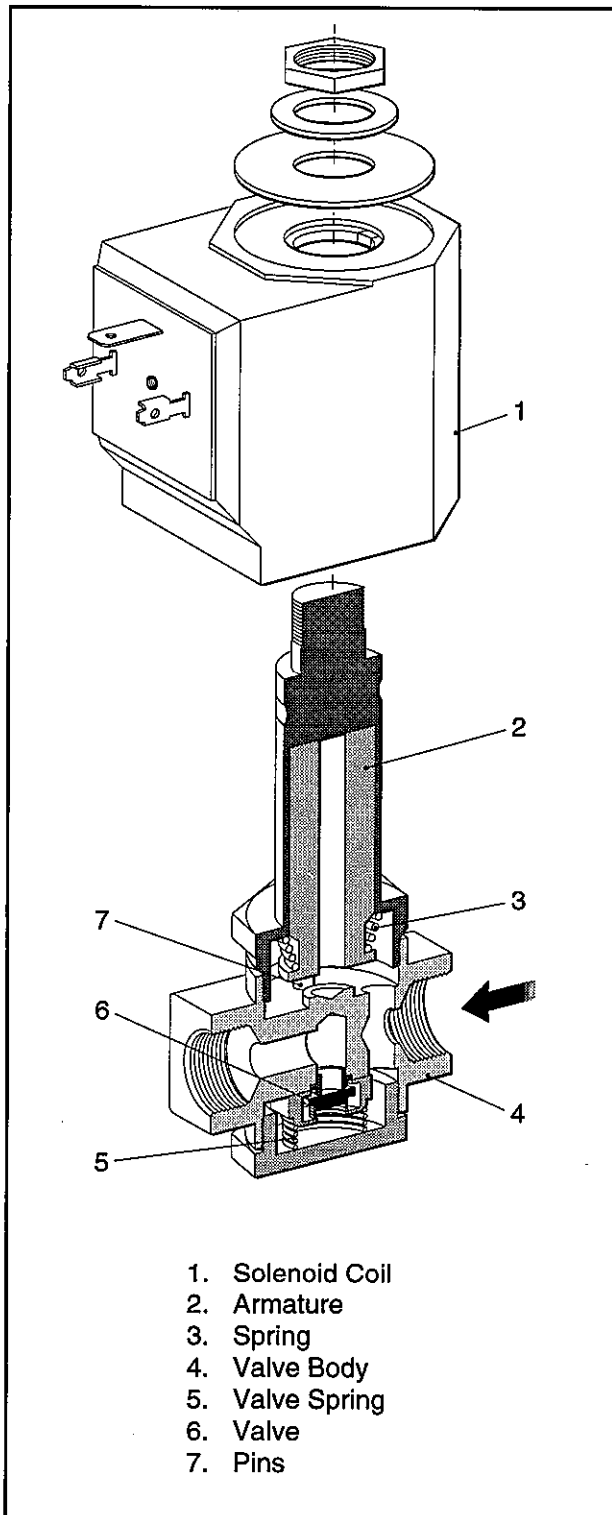


FIG. 5.11 UNLOADER SOLENOID VALVE

### 9.1 Description

An unloader solenoid valve is used to load and unload the compressor by regulating the air supply to the suction regulator.

The solenoid valve incorporates a 24V 50/60Hz coil which operates in response to a signal from the controller. The controller uses a pressure transducer to measure air delivery pressure to provide a load/unload signal to the solenoid.

### 9.2 Operation

When the solenoid coil (1) is de-energised, the valve (6) opens under the force of a spring (3) which causes the armature (2) to lift the two pins (7) against the outer face of the valve. The outlet port is then connected to the inlet port allowing air to flow through the valve body (4) to the suction regulator causing the inlet valve to close and the compressor to run off-load.

Air flow through the unloader solenoid valve is through a 3 mm orifice which is critical in maintaining a balanced system when the compressor is running off-load.

When the solenoid coil is energised, the armature is pulled into the coil allowing the valve to close under the action of a spring (5). Air is exhausted to atmosphere from the suction regulator allowing the inlet valve to open and the compressor to run on-load.

## 10. PRESSURE TRANSMITTER

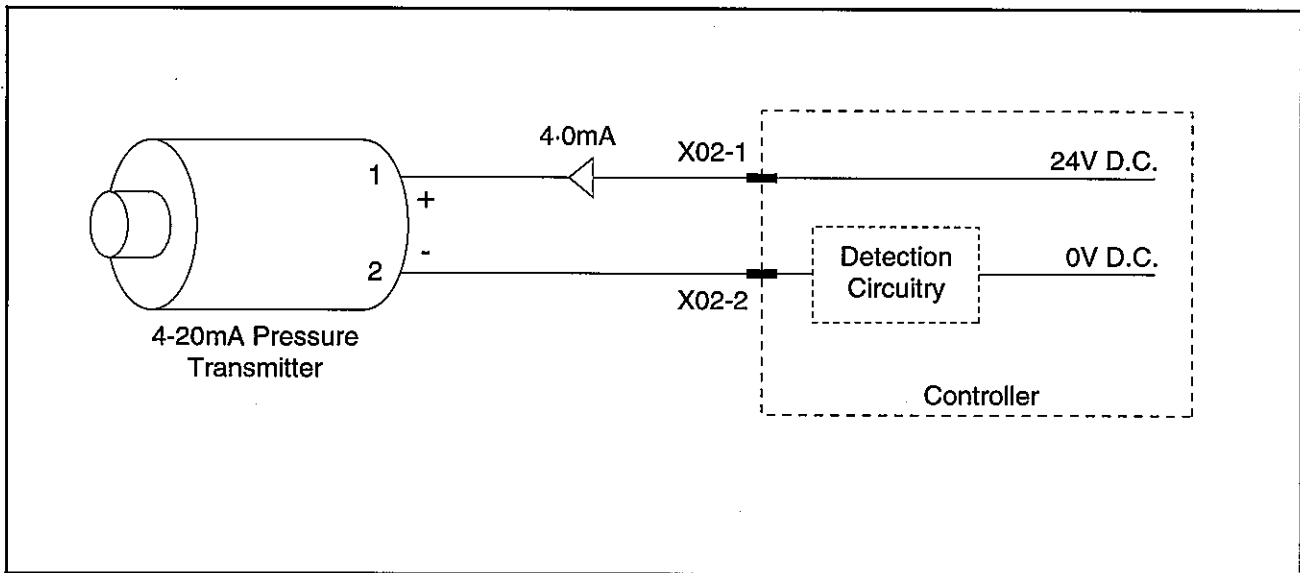


FIG. 5.12 PRESSURE TRANSMITTER

### 10.1 Description

The air pressure in the user's pipework is continuously monitored by a 4-20 mA pressure transmitter which converts the pressure into an electrical signal.

See the pressure transmitter output table in Chapter 7 – 9.1 'To Check the Pressure Transmitter (P201)'.

### 10.2 Operation

The transmitter converts air pressure into a linear change of electrical current flowing in the two power supply wires to the transmitter. Typically, the current will change from 4 mA at 0.0 bar to 20 mA at 16.0 bar.

The controller detects the current flowing in the 24 Volt dc power supply wires to the transmitter and converts this into a linear voltage signal. This signal is processed within the controller and displayed as a pressure reading

The controller can recognise an 'out of range' signal if a pressure transmitter fault occurs. This will be displayed as a pressure probe fault.

## 11. TEMPERATURE SENSOR

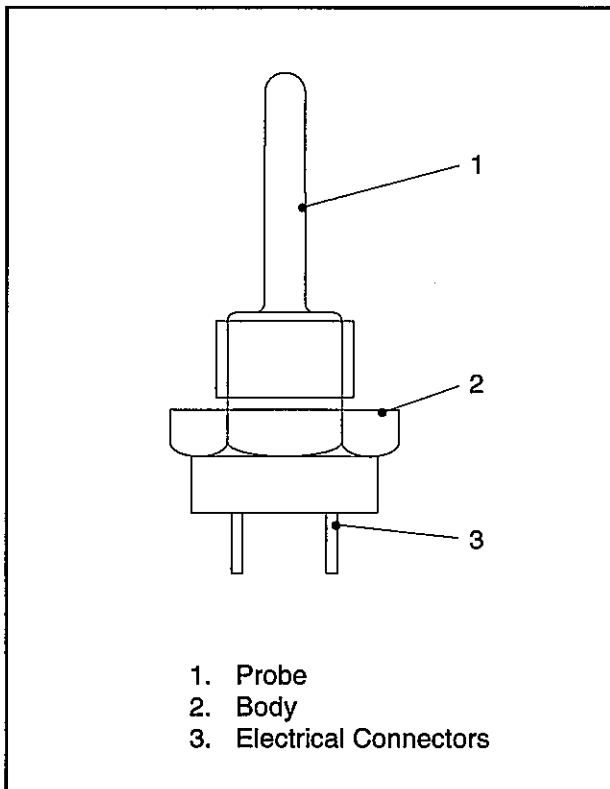


FIG. 5.13 TEMPERATURE SENSOR

### 11.1 Description

A temperature sensor is installed in the air-end adjacent to the delivery port. The sensor protects the compressor unit against excessive discharge temperature by sensing the temperature of the compressed air/oil mixture discharged from the air-end. The resistance of the sensor increases with temperature.

### 11.2 Operation

The resistance of the temperature sensor is monitored by the controller. This signal is processed within the controller and displayed as an air/oil temperature reading. A high oil temperature warning and/or compressor shut-down is activated if the temperature of the air/oil mixture reaches the programmed trip setting.

The controller can recognise an 'out of range' signal if a temperature sensor fault occurs. This will be displayed as a sensor fault.

Temperature (°C)	Sensor Resistance (ohms)	Temperature (°C)	Sensor Resistance (ohms)
0	1605	50	2448
5	1678	60	2638
10	1762	70	2844
15	1848	80	3058
20	1927	90	3282
25	2008	100	3520
30	2092	110	3772
40	2263	120	4043



---

# CHAPTER

# 7

## ELECTRICAL SYSTEM

<b>Description</b>	<b>Page</b>
Control System	1
Component Description	1
Controller	1
Starter Assembly	3
Starter Contactor Auxiliary Contacts	3
Control Function Options	4
Automatic Restart	4
Remote Start/Stop Facility	4
Remote Load/Unload	5
Remote Group Fault Output	6
Fault Diagnosis	7
Test Equipment	7
Test Meter	7
Clip-On Ammeter	7
Insulation Tester	7
Slave Air Supply	7
Cage-Clamp Screwless Terminals	8
Cable Connection Or Removal	8
Displayed Fault Conditions	9
Observed Fault Conditions	9
Power Supplies	10
To Check The 24v Ac Supply Circuits	10
To Check The Main Power Supply	10
Motor And Motor Control Circuit	10
To Check The Main Motor	10
Control Inputs	11
To Check The Air Filter Differential Pressure Switch (S102)	11
To Check The Emergency Stop Circuit	12

*Continued . . .*

---

---

<b>Description</b>	<b>Page</b>
<i>Fault Diagnosis (continued)</i>	
Power Supplies	14
Control Outputs	12
Motor Contactor And Load Solenoid	12
Scavenge Solenoid	13
Sensors	14
To Check The Pressure Transmitter (P201)	14
To Check The Temperature Sensor (R201)	16
Controller	16
Control Card	17
Control Program IC	17

---

## CONTROL SYSTEM

### 1. COMPONENT DESCRIPTION

The electronic control system is microprocessor based with an LED display panel, incorporating advanced control and monitoring features.

#### 1.1 Controller

The controller is designed for dedicated compressor control and monitoring and consists of an electronic microprocessor based system with (LED) display and indicators, tactile switches and mimic diagram. The controller consists of a single control card connected to ancillary monitoring and control components and motor starter assembly.

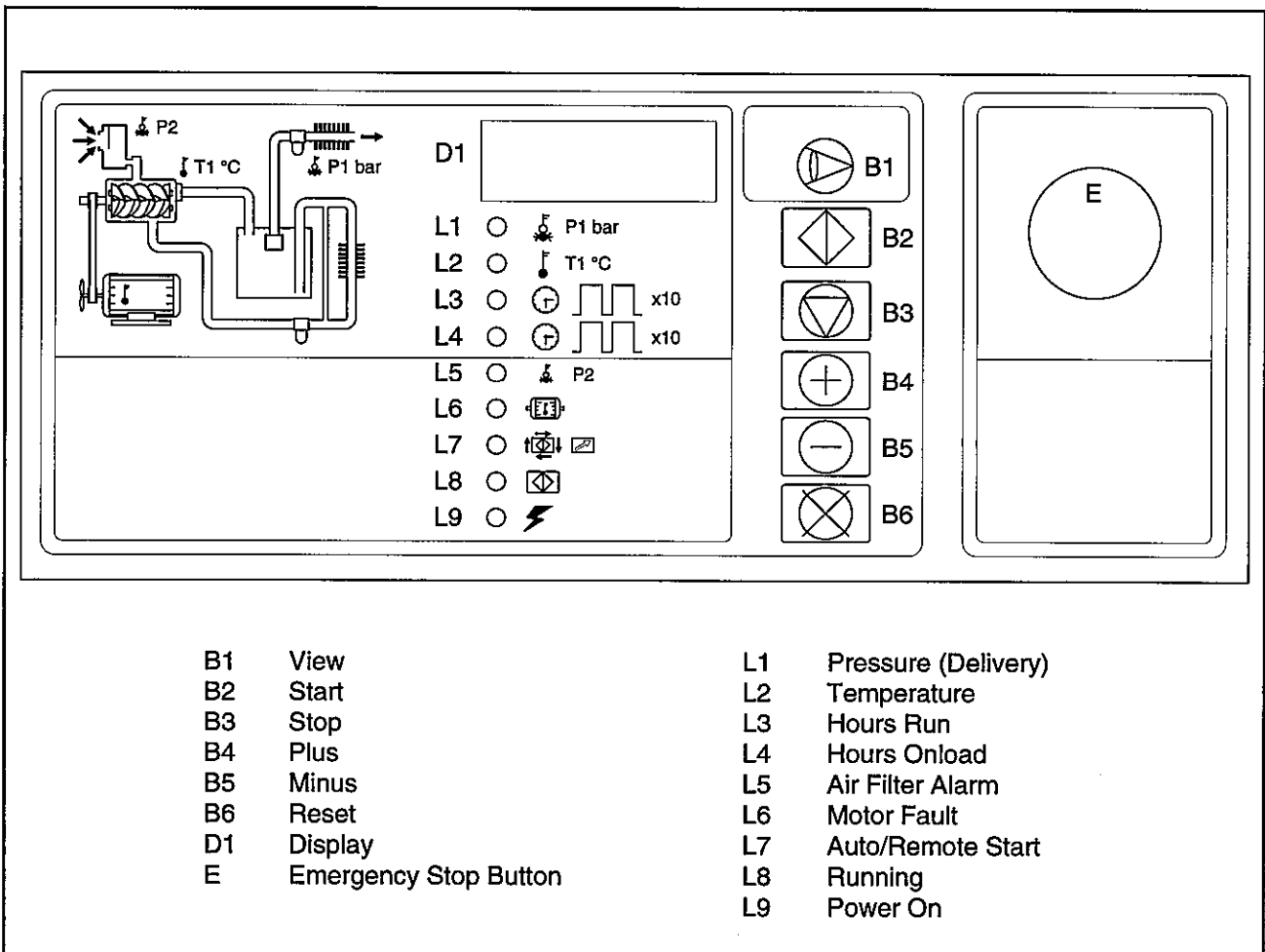


FIG. 7.1 CONTROL PANEL

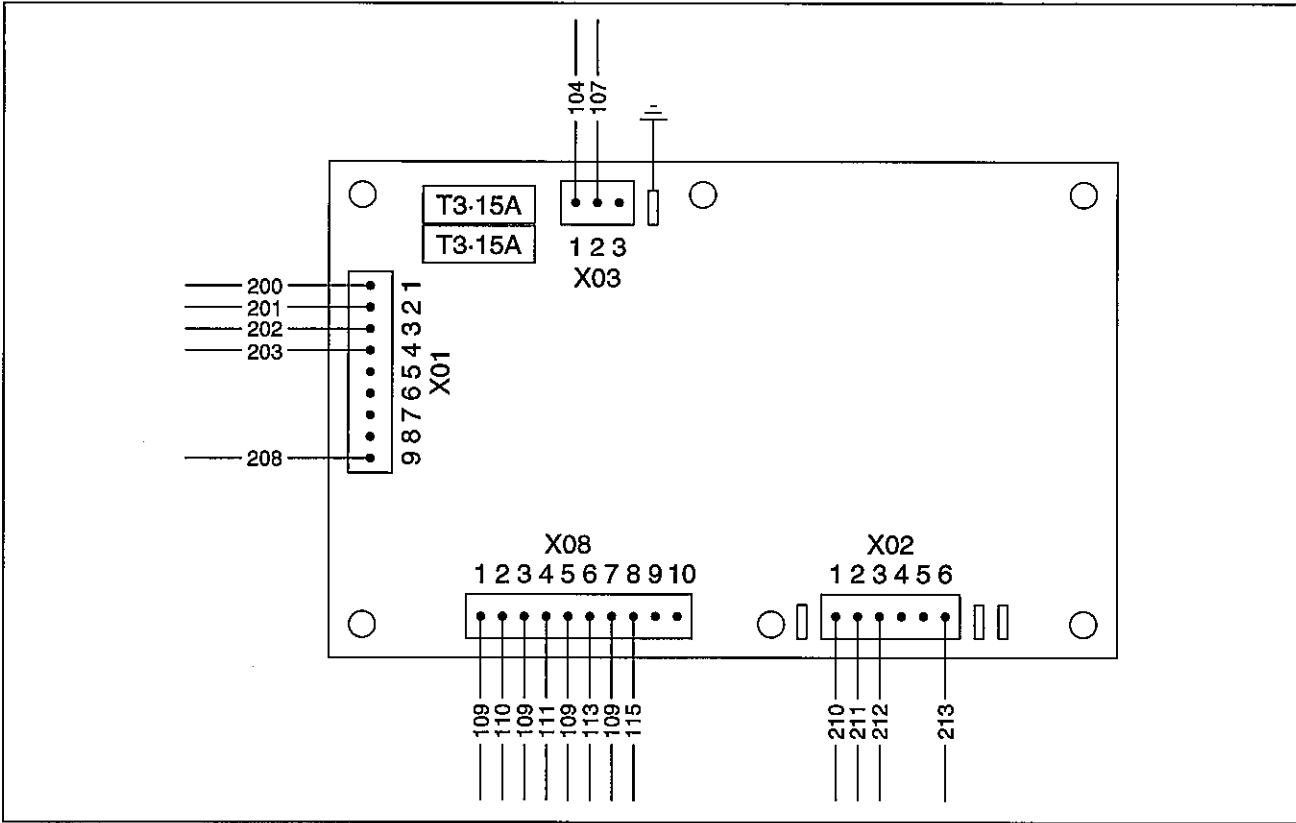


FIG. 7.2 CONTROLLER (REAR CONNECTIONS)

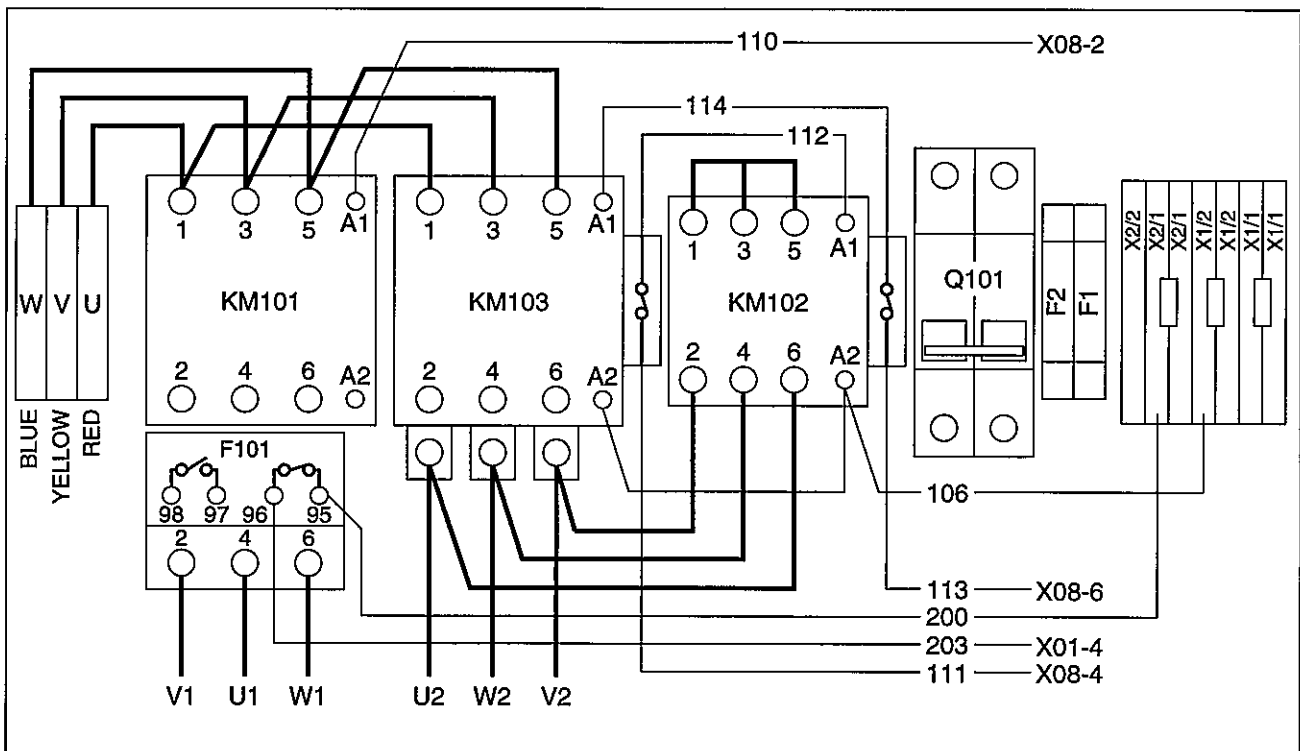


FIG. 7.3 STARTER ASSEMBLY

## 1.2 Starter Assembly

The starter assembly consists of three contactors, Main (KM101), Star (KM102) and Delta (KM103), and a main motor thermal overload relay (F101). The coils of the three contactors are rated for 24V ac, 50/60 Hz

### 1.2.1 Wiring

Each control or signal wire is labelled with an individual wire number. Wires having a common function, power supply wires for example, are labelled with the same number and originate from the same terminal block.

The wiring for low voltage control, signal and 24V power supply is 1.0 mm<sup>2</sup> in size. Starter control wiring, which carries main power supply voltage is larger in diameter and is instantly recognisable.

### 1.2.2 Power Supply Circuit Breakers and Fuses

Two phases of the main power supply are connected to MCB Q101 which protects the power supply circuit to transformer T101. To ensure correct operation the power supply wires to the primary of transformer T101 must be connected to the correct voltage terminals for the nominal operating voltage rating of the compressor.

The control transformer T201, has two 24V ac outputs. Each output is individually protected by fused terminal blocks F1 and F2. Fuse F1 protects the controller power supply circuit and fuse F2 protects the controller output circuits.

## 1.3 Starter Contactor Auxiliary Contacts

Some BroomWade motor contactors have clip-on auxiliary contacts which are designed to operate in N/O (normally open) or N/C (normally closed) mode, depending on orientation. The auxiliary contact (2) clips onto the front face of the contactor (1). The operation of the contact is determined by the N/O or N/C pictorial symbol furthest from the contactor face when fitted. To remove the contact, pull the release catches (3), (located top and bottom of the contact) away from the contactor and slide the contact sideways.

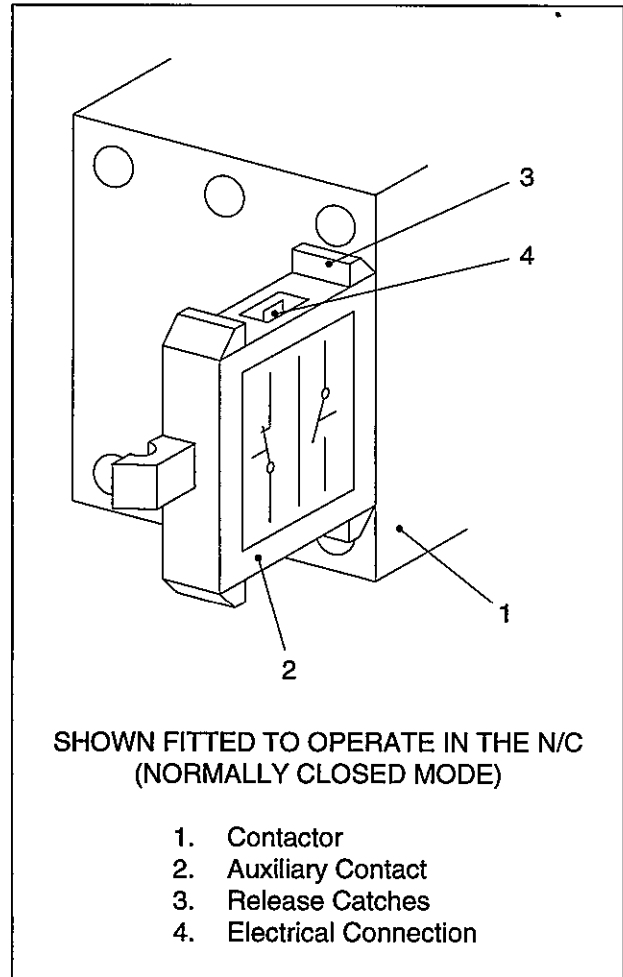


FIG. 7.4 AUXILIARY CONTACT

**2. CONTROL FUNCTION OPTIONS**

<span style="font-weight: bold; margin: 0 10px;">WARNING</span>
<ul style="list-style-type: none"> <li style="display: inline-block; width: 45%; vertical-align: top;"> <ul style="list-style-type: none"> <li>● Refer to the safety procedures before carrying out any of the following options.</li> </ul> </li> <li style="display: inline-block; width: 45%; vertical-align: top;"> <ul style="list-style-type: none"> <li>● Lethal voltages are used in this equipment. Use extreme caution when carrying out electrical checks. Isolate the power supply before starting any maintenance work.</li> </ul> </li> </ul>

**Note:** We recommend that the following procedures are carried out by a CompAir BroomWade distributor.

**2.1 Automatic Restart**

Automatic restart will allow the compressor to start automatically after a break or failure in the mains power supply. When this facility is enabled the Remote start / Auto restart indicator (L8) will be lit.

1. To enable Automatic restart select an Automatic restart delay time of greater than zero seconds using the 'Program Mode'.
2. To disable Automatic restart select an automatic restart delay time of zero seconds.
3. When power is restored after a break or failure of the main supply power, the Remote start/ Auto restart indicator (L8) will flash for the programmed Auto restart delay time. This provides a warning before the compressor restarts. The compressor motor will automatically restart and continue to run after the auto restart delay time expires.
4. The compressor will only automatically restart if the compressor was in the Onload, Offload or Standby mode when the break or failure in main supply power occurred.

**2.1.1 Automatic Restart Delay Time**

The Auto restart delay time can be adjusted using the 'Program Mode'.

In multiple compressor installations, staggered restarting can be achieved by adjusting the delay time of each compressor differently.

Example - Four compressor installation:

Compressor	Autorestart delay time
1	60 seconds
2	120 seconds
3	180 seconds
4	240 seconds

**2.2 Remote Start/Stop Facility**

**2.2.1 Remote Start**

The remote start facility will enable the compressor to be started from a remote location.

1. When this option is selected, the Remote control/Auto re-start indicator (L8) will be lit and the *START* button (B2) on the compressor panel is disabled; all *STOP* functions are unaffected.
2. To enable the remote start facility connect a length of wire between terminal X2/1 and controller terminal X01, pin 7.
3. The compressor can be remotely started if remote start terminal X01, pin 8, is connected via a remote normally open button or other switching device, to terminal X2/1. The connection can be a pulse of at least 0.5 seconds or continuous.

### 2.2.2 Remote Stop

The remote stop facility will enable the compressor to be stopped from a remote location.

1. The remote stop is active at all times, regardless of the remote start facility being enabled.
2. The compressor can be stopped remotely by disconnecting the wire link between terminals X2/1 and X2/2 via a remote normally closed button or other switching device.

### 2.3 Remote Load/Unload

The remote load/unload facility enables the compressor to be pressure controlled by a remote pressure switch, pressure control system or cascade panel.

1. To enable the remote Load/Unload facility connect a length of wire between terminal X2/1 and controller terminal X01, pin 5.
2. When this option is selected the compressor will load when terminal X01, pin 6 is connected, via a remote pressure switch, cascade control panel or other switching device, to terminal X2/1.
3. The compressor will unload when the connection between X01, pin 6 and X2/1 is broken.

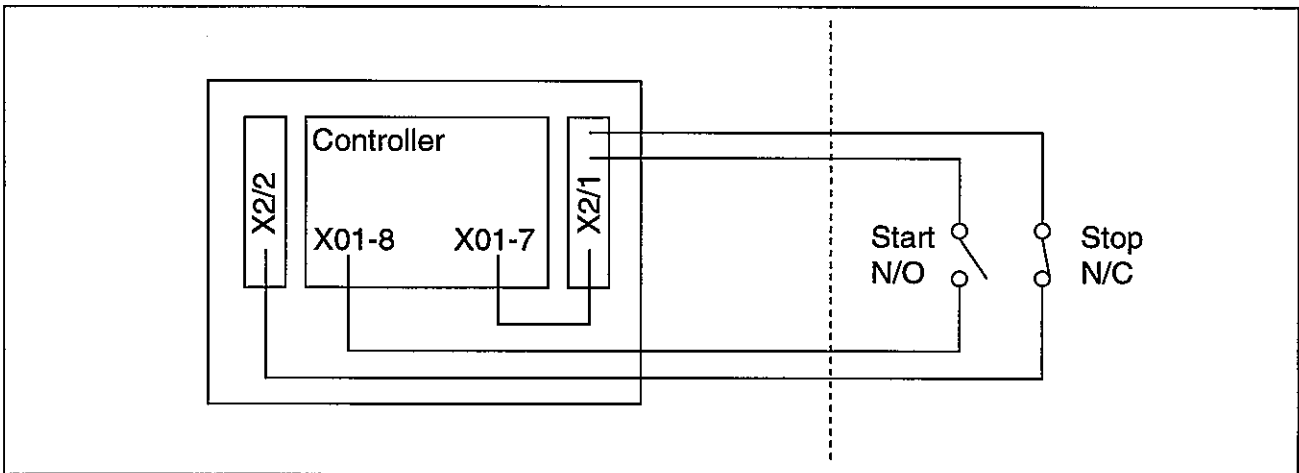


FIG. 7.5 REMOTE START/STOP

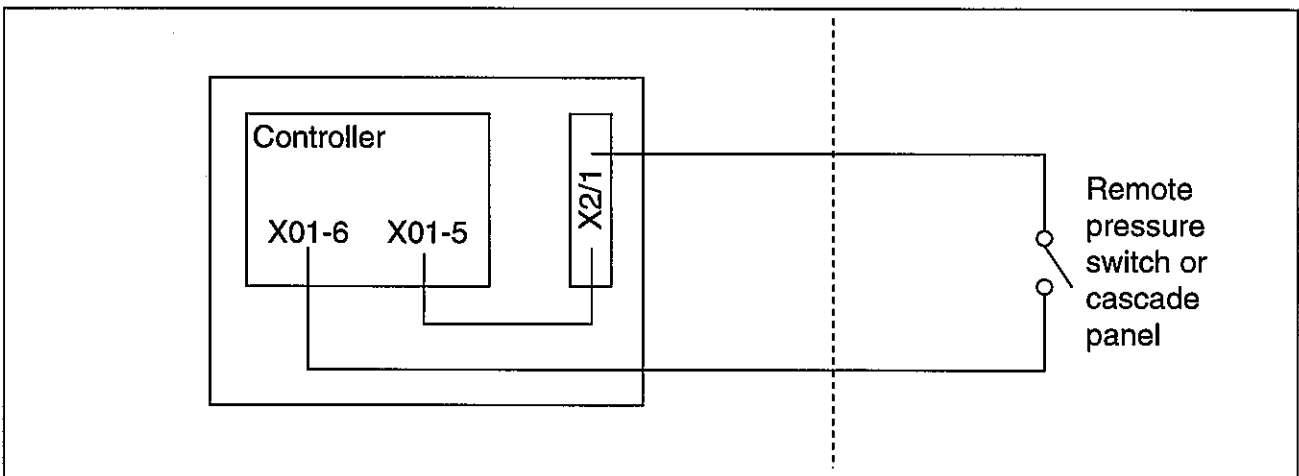


FIG. 7.6 REMOTE LOAD/UNLOAD

## 2.4 Remote Group Fault Output

### 2.4.1 Group Fault Relay

The control card is fitted with a group fault relay, the relay contacts being available for switching remote facilities. The relay contacts are rated for a maximum of 250V ac at 5A and are connected to controller terminal X08, pins 9 and 10.

### 2.4.2 Group Fault Relay Operation

When power is switched ON, and no alarm or trip is detected, the group fault relay will energise and the contacts will close circuit. If an alarm or fault is detected or a power failure occurs, the relay will de-energise and the contacts will open circuit. The relay will energise again when the controller is reset and no further alarm or trip condition exists.

### 2.4.3 Group Fault Relay - Example

If the output is required for switching a remote fault lamp or an audible alarm, for example, an additional relay 98475-71 and base 98475-72 will be required as shown in the diagram below:-

**Note:** If the compressor has been out of operation for a prolonged period it is advisable to carry out the full commissioning procedure before starting.

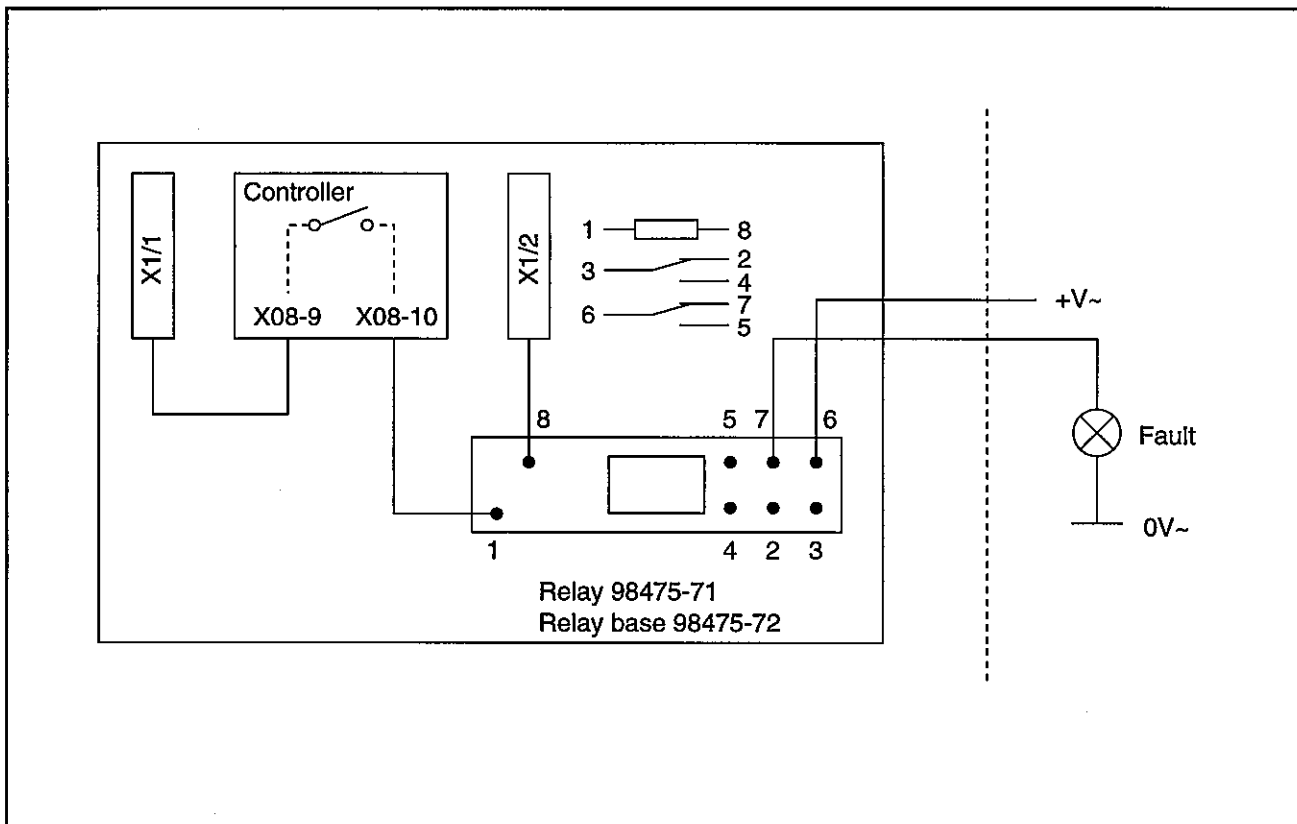






FIG. 7.7 GROUP FAULT RELAY – EXAMPLE

## FAULT DIAGNOSIS

WARNING

- Refer to the safety procedures before carrying out any checks on the electrical circuits or components

- Lethal voltages are used in this equipment. Use extreme caution when carrying out electrical checks. Isolate the power supply before starting any maintenance work.

**CAUTION:** Fault finding by control card substitution instead of following correct fault finding procedures is not recommended. A fault may exist which could cause damage to the substitute card.

### 1. TEST EQUIPMENT

To carry out the checks on the electrical components and the circuit cards inputs and outputs the following test equipment will be required.

**CAUTION:** Do not use a test meter with less than a 20,000 ohm/V specification to avoid loading effects and to prevent damage to IC's during testing.

**CAUTION:** The circuit boards carry CMOS devices. When replacing circuit boards avoid touching connector pins and devices on the boards to prevent static damage to components. Take anti-static precautions as far as possible such as transporting the circuit boards in anti-static bags.

**CAUTION:** When using an analogue multimeter to check continuity or measure resistance, particularly low resistances such as solenoid coils, ensure that the meter has been adjusted to read zero ohms correctly with its test probes connected together, before any measurement is made.

#### 1.1 Test Meter

A multimeter (either analogue or digital) is required for the tests carried out in this section. If an analogue meter is used it should be 20,000 ohms/V minimum. The resistance range test voltage

should not exceed 1.5V. The following ranges, as provided by an AVO 8 Mk7, are suitable and are quoted in the tests. If a different meter is used or a digital meter the nearest higher ranges should be used. A digital meter (say an AVO M2000 series) will also give an alternative lower range of (0 -300 ohms) which will give more accurate continuity and solenoid coil measurements.

dc volts: 0-30V (for 24V measurements)

ac volts 0-30V (for 24V measurements)

0-600V (for main supply measurements)

Resistance: 0-2 kohms

#### 1.2 Clip-on Ammeter

This should be suitable for measuring currents up to 600 amps.

#### 1.3 Insulation Tester

The tester should have a 1000V test voltage.

#### 1.4 Slave Air Supply

The air supply should be capable of generating a pressure above 5.51 bar and be fitted with an accurately calibrated gauge.

## 2. CAGE-CLAMP SCREWLESS TERMINALS

The connections on the interface assembly and controller terminal blocks are fitted with cage-clamp screwless terminals. The cage-clamp design ensures that the clamping force adjusts to sizes of cable between 1 mm<sup>2</sup> and 2.5 mm<sup>2</sup>. This results in a corrosion free contact area and compensates for any deformation of the cable end due to temperature or vibration.

### 2.1 Cable Connection or Removal

1. Strip the insulation from the end of the cable to leave approximately 5 mm of bare wire.
2. Insert a screwdriver with a blade end width of 3 mm into the terminal slot and push to the end stop.
3. Inset (or remove) the cable.
4. Withdraw the screwdriver to leave the cable clamped.
5. Check the connection by lightly pulling on the cable.

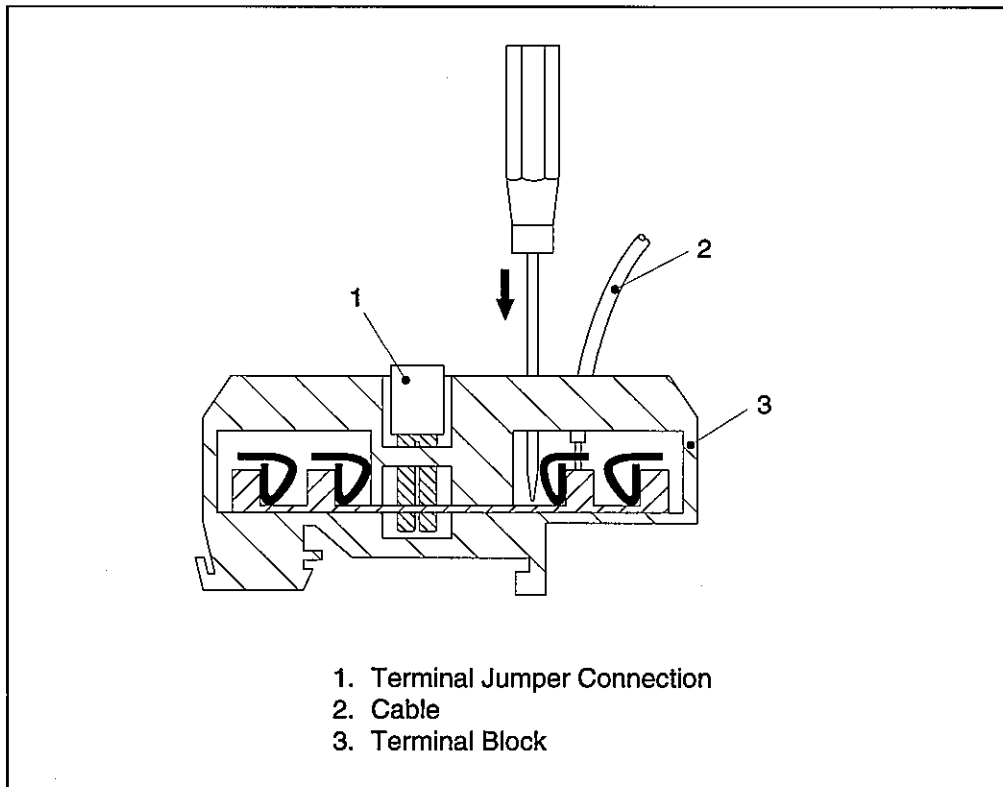


FIG. 7.8 CABLE CONNECTION OR REMOVAL

### 3. DISPLAYED FAULT CONDITIONS

Ref.	Message Displayed	Possible Fault	See section:
1.	Change air filter	Air Filter Differential Pressure Switch circuit.	7.1
2.	High oil temp alarm	Temperature Sensor circuit.	9.2
3.	Emergency stop	Emergency Stop circuit.	7.5
4.	High air pressure	Pressure Sensor circuit	9.1
5.	High oil temp trip	Temperature Sensor circuit.	9.2
6.	Main motor trip	a) Main Motor. b) Main Motor overload. c) Main Power Supply.	6.1 5.2
7.	Press sensor fault	Pressure Sensor circuit.	9.1
8.	Temp sensor fault	Temperature Sensor circuit	9.2

### 4. OBSERVED FAULT CONDITIONS

Ref.	Symptom	Possible Fault	See section:
1.	High main motor temperature.	Main Power Supply.	5.2
2.	High discharge air temperature.	Temperature Sensor circuit.	9.2
3.	Low discharge air pressure.	a) Pressure Sensor circuit. b) Unloader Solenoid circuit.	9.1 8.1
4.	High discharge air pressure.	a) Pressure Sensor circuit. b) Unloader Solenoid circuit.	9.1 8.1
5.	Compressor unit will not start	a) Remote starting has been enabled.  <b>Indicator L8 illuminated</b>  b) The emergency stop button has not been reset.  <b>All indicators flashing</b>	Operate the compressor remotely or remove the remote start enable connection.  Reset the emergency stop button by turning anti-clockwise, then press RESET
7.	Machine will not run on load pressure display is correct.	Unloader Solenoid circuit.	8.1
8.	Machine will not run offload pressure display is incorrect.	Pressure Sensor circuit.	9.1

## 5. POWER SUPPLIES

**CAUTION:** The high voltage (primary) and low voltage (secondary) circuits must NOT be connected in any way (e.g. via test probes, wiring etc.)

### 5.1 To Check the 24V ac Supply Circuits



1. Measure the ac voltage of the two 24V secondary outputs of transformer T201. Always measure across the transformer output terminals and NOT between each terminal and earth.
2. The voltage of each output should be in the range 20V to 28V. If one of the voltages is incorrect, renew the transformer. If both the voltages are incorrect see 5.2 'To Check the Main Power Supply'.
3. Check the fuses contained in the fused terminal blocks F1 and F2. Renew any fuse found to be blown. If a fuse blows repeatedly continue to check along the circuit for any short circuits or failed devices, as explained in detail throughout this Chapter.
4. Measure the ac voltage between pins 1 and 2 of controller terminal X03. The voltage should be the same as measured in point 2. Renew cables 104 and 107 if the voltage is incorrect.
5. Measure the ac voltage between terminals X1/1 and X1/2. The voltage should be the same as measured in point 2. Renew cables 106 and 109 if the voltage is incorrect.

### 5.2 To Check the Main Power Supply

1. Measure and record the voltage between the Red and Yellow, the Red and Blue, and the Yellow and Blue incoming phases. In addition measure the ac voltage between the primary connections of control transformer T101. The readings should be within 6% of the specified working voltage on the compressor nameplate.
2. Measure and record any voltage drop during a motor start sequence. Any voltage drop will cause an increase in normal starting current. Excessive increases will cause tripping problems.

3. If tripping occurs on start-up check the connections in the remote isolator or fuse box enclosure. If the connections are good check the main supply cable sizes and the fuse/circuit breaker rating and type.

## 6. MOTOR AND MOTOR CONTROL CIRCUIT

	<b>WARNING</b>	
<ul style="list-style-type: none"><li>● Refer to the safety procedures before carrying out any electrical checks.</li></ul>		

### 6.1 To Check the Main Motor

#### 6.1.1 Motor Insulation

1. **Ensure that the main power supply to the compressor is isolated.**

**Note:** Use a calibrated 1000V insulation tester for insulation resistance tests.

2. Measure the insulation resistance between each motor winding phase, i.e. cables V1-U1, V1-W1 and U1-W1.
3. The readings between each of the phases should be greater than 2 megohms.
4. If the insulation resistance is zero an inter-winding short circuit exists. Renew/service the main motor.
5. If the insulation resistance is below 2 megohms conductive material or moisture is present in the motor. Service the main motor.
6. Measure the insulation resistance between each motor winding phase cable (U1, V1 and W1) and earth.
7. If the insulation resistance is below 2 megohms renew/service the main motor.
8. Carry out the motor current tests below.

**CAUTION:** DO NOT apply power to a motor which has an insulation resistance of less than 2 megohms.

### 6.1.2 Motor Current

1. Check that the motor nameplate shows the correct working voltage for the compressor mains supply. Record the details given on the plate, i.e.:

Motor type  
 Motor serial number  
 Working voltage  
 Full load line current (FLC) figure.

**Note:** Motors which operate over a voltage band will give full load line current figures for both the minimum and maximum working voltages.

2. Switch power on and start the compressor.
3. Using a calibrated pressure gauge ensure that the compressor delivery pressure does not exceed its rated working pressure.

Measure and record the ac mains supply voltage. If this is incorrect see 5.2 'To Check the Mains Power Supply'.



4. If the supply voltage is correct use a calibrated clip-on ammeter to measure and record the currents in the motor cables U1, V1 and W1.
5. Add together the three motor (delta loop) currents and divide by three to get the average. If any one of the currents is more than 5% different from the average it is more likely that a phase voltage imbalance exists rather than a motor fault, see 5.2 'To Check the Mains Power Supply'.
6. Multiply the average motor current by 1.732 to get a 'line' current figure. This is the full load current (FLC) of the motor (provided the compressor is on full load).
7. If the measured working FLC figure exceeds 5.6% above the figure given on the motor plate, renew/service the motor.

For reference, typical FLC figures for 3-phase, standard production, squirrel cage compressor main motors are:

Motor		FLC		
hp	kW	415V	380V	220V
7	5.0	11	12	20
10	7.5	14	15	27
15	11.0	22	24	41
20	15.0	28	31	55
25	18.5	33	36	64
30	22.0	39	42	73

The currents quoted above are typical values for standard motors of the specified rating. Full load currents will vary from motor to motor and the FLC for a particular motor should be established from the motor nameplate.

## 7. CONTROL INPUTS

	<b>WARNING</b>	
● Refer to the safety procedures before carrying out any electrical checks.		

**CAUTION:** The high voltage (primary) and low voltage (secondary) circuits must NOT be connected in any way (e.g. via test probes, wiring etc.)

### 7.1 To Check the Air Filter Differential Pressure Switch (S102)

The air filter differential pressure switch contacts are normally open. This indicates that the air filter element differential pressure is within limits. When the filter requires changing the inlet valve suction exceeds 65 mbar below atmospheric pressure and the contacts of switch S102 close.

1. Disconnect the cables from the pressure switch.
2. Check that the pressure switch is open circuit by checking continuity between the switch terminals.
3. Renew the pressure switch if closed circuit.

4. Check the continuity between plug pins ML1/11 and ML1/12. Renew cables if closed circuit.
5. Check continuity between controller terminal X01/3 and socket pin ML1/11 and between terminal block X2/1 and socket pin ML1/12.
6. Renew cables 202 and 200 as necessary.

## 7.2 To Check the Emergency Stop Circuit

The Emergency Stop button has two normally closed ( N/C ) contacts which will open circuit if the Emergency Stop button is pressed. One contact is connected to the 24V ac power supply circuit to the controller outputs. This contact will interrupt the power supply to the motor contactors and control solenoids in the event of an Emergency Stop. The other contact is connected to the input circuits of the controller.

### 7.2.1 24V ac Power Supply Interrupt Circuit.

1. Ensure the main power supply is switched off and isolated.
2. Ensure the Emergency Stop button is reset by rotating the button as indicated by an arrow. The button will unlatch and reset.
3. Ensure fuse F2 has not blown.
4. Measure the continuity between terminal F2 and terminal X1/1.
5. Renew the two wires labelled 109 and the Emergency Stop contact if continuity does not exist.

### 7.2.2 Controller Detection Circuit.

1. Ensure the main power supply is switched off and isolated.
2. Ensure the Emergency Stop button is reset by rotating the button as indicated by an arrow. The button will unlatch and reset.
4. Measure the continuity between pin 2 of controller terminal X01 and terminal X2/1.

5. Renew wires 200 and 201 and the Emergency Stop contact if continuity does not exist.

## 8. CONTROL OUTPUTS



### WARNING

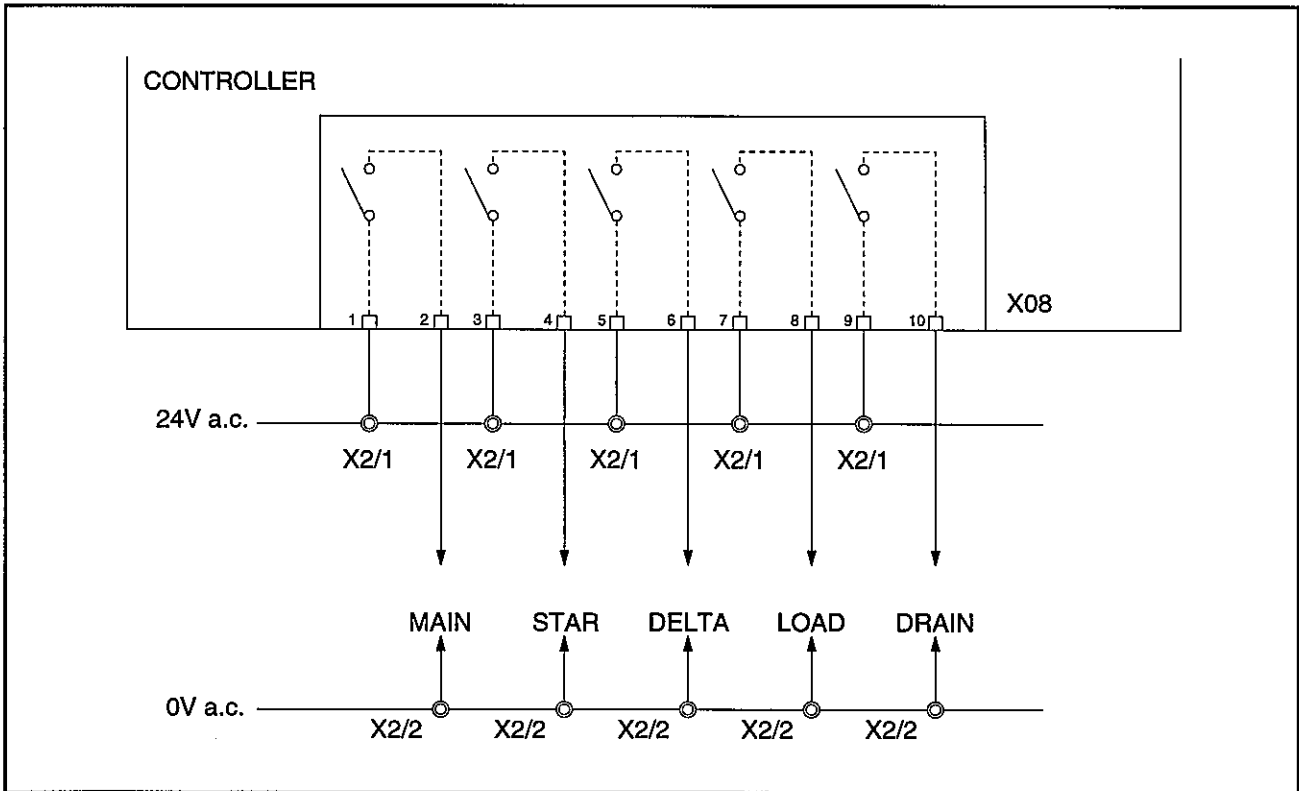


- Refer to the safety procedures before carrying out any electrical checks.

**CAUTION:** The high voltage (primary) and low voltage (secondary) circuits must NOT be connected in any way (e.g. via test probes, wiring etc.)

### 8.1 Motor Contactor and Load Solenoid

1. Ensure the Emergency Stop input has not been operated before checking the outputs, see 7.5 'To Check the Emergency Stop Circuit'
2. The motor contactors and load solenoid controller outputs are all relay contacts.
3. When checking an output ensure the 24V ac supply from terminal X1/1 is good.
4. Measure the voltage between terminal X1/2 and the output terminal, while the output is operated.
5. If an output fails to function renew the controller.
6. Continue to check the output voltage along the circuit being tested. Renew any connections or wiring as necessary.
7. If the voltage across the terminals of the contactor or solenoid coil being tested is within the range 20V to 28V ac when the controller output is switched on, renew the contactor coil or solenoid.



**FIG. 7.9 CONTROLLER RELAY CONTACT OUTPUTS**

## 8.2 Scavenge Solenoid

The scavenge solenoid and timer unit are connected directly to the 24V ac supply. The Scavenge solenoid will cycle continuously when power is applied to the compressor regardless of the operational mode of the compressor. The 24V ac supply to the timer unit is only interrupted when the Emergency Stop button is activated.

The scavenge solenoid is controlled by a timer unit which connects directly to the solenoid. The timer will switch power to the solenoid coil off for five seconds every forty seconds.

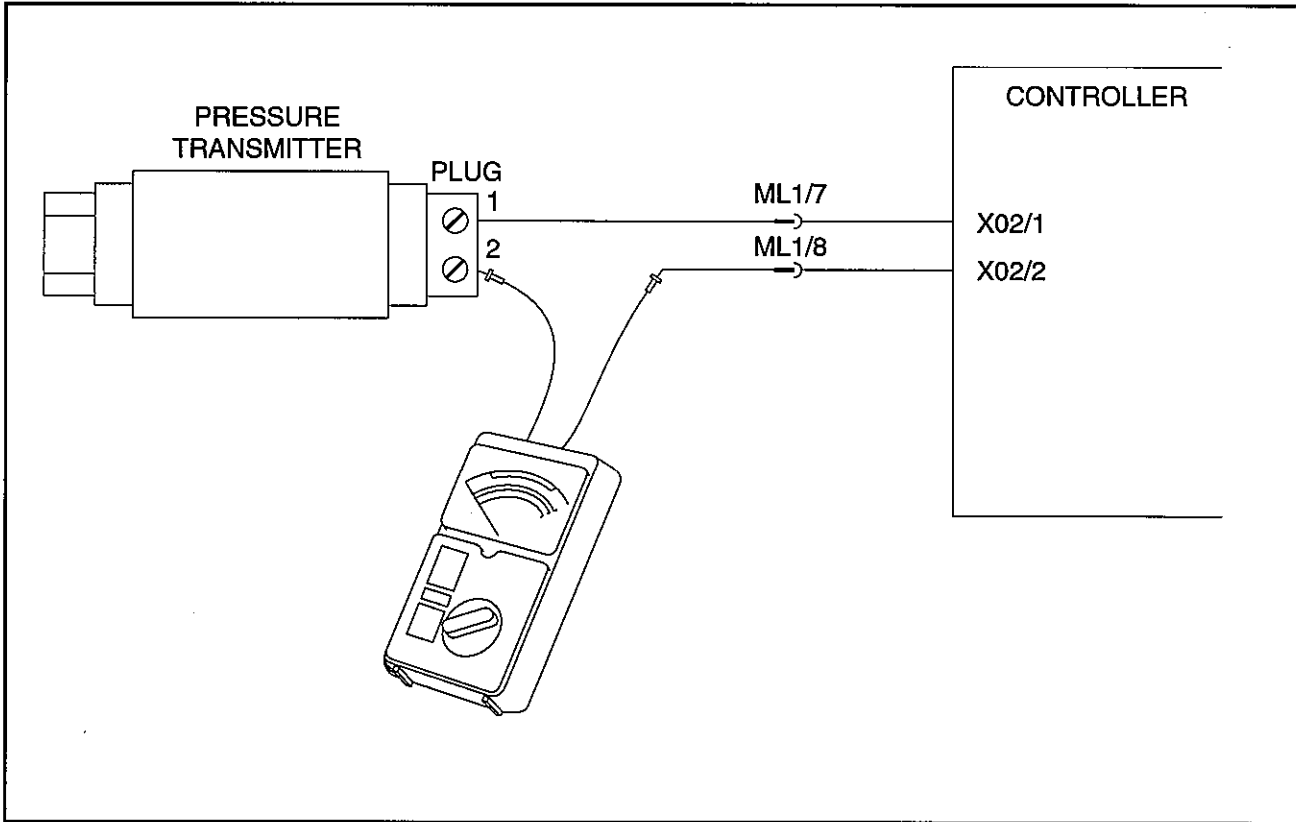


FIG. 7.10 MEASURING THE TRANSMITTER CURRENT

9. SENSORS

9.1 To Check the Pressure Transmitter (P201)

<span style="font-weight: bold; font-size: 1.2em; margin: 0 10px;">WARNING</span>
<ul style="list-style-type: none"> <li>● Refer to the safety procedures before carrying out any electrical checks.</li> </ul>

The Pressure Transmitter is a 4-20 mA, 0-16 Bar type. The current in the transmitter 24V dc power supply wires will change in proportion to the pressure acting on the Pressure Transmitter. The controller monitors the current signal and processes the information to give a pressure display.

**CAUTION:** The high voltage (primary) and low voltage (secondary) circuits must NOT be connected in any way (e.g. via test probes, wiring etc.)

1. Switch power off.
2. Remove the plug from the pressure transmitter, switch power ON and ignore any displayed fault message.
3. Measure the dc voltage across the two plug terminals. The reading should be between 20V and 28V.

4. If the voltage is incorrect see 'To Check The 24V ac Supply Circuits'.
5. Re-connect the pressure transmitter plug and disconnect one of the plug wires.
6. Connect the multimeter between the disconnected end of the wire and the plug terminal.
7. Apply a calibrated known pressure to the transmitter and measure the dc current. The reading should be as given in the Pressure Transmitter output table below.
8. If the current is not within  $\pm 5\%$  of the figure given check the wiring and connections of the pressure transmitter circuit.
9. Renew the pressure transmitter if no wiring or connection faults can be found.

Pressure (bar)	Transmitter Output (mA)	Pressure (bar)	Transmitter Output (mA)
0.0	4.00	7.5	11.50
0.5	4.50	8.0	12.00
1.0	5.00	8.5	12.50
1.5	3.50	9.0	13.00
2.0	6.00	9.5	13.50
2.5	6.50	10.0	14.00
3.0	7.00	10.5	14.50
3.5	7.50	11.0	15.00
4.0	8.00	11.5	15.50
4.5	8.50	12.0	16.00
5.0	9.80	12.5	16.50
5.5	10.38	13.0	17.00
6.0	10.96	13.5	17.50
6.5	11.54	14.0	18.00
7.0	12.12	14.5	18.50
		15.0	19.00
		15.5	19.50
		16.0	20.00

**9.2 To Check the Temperature Sensor (R201)**

The Air/Oil Temperature Sensor is a spreading resistance type thermistor. The resistance of the thermistor will increase as the applied temperature increases. The controller monitors the resistance and processes the information to give a temperature display.

1. Switch power off. Disconnect the cables from the temperature sensor and measure its resistance.

**Note:** The temperature sensor can be removed and the sensing tip placed in a calibrated oil temperature bath if an accurate measurement is required.

2. The sensor resistance depends on the temperature, see the Temperature/Sensor resistance table below. If the measured resistance equates to an error of more than  $\pm 2^{\circ}\text{C}$  different from the figure given below renew the sensor.
3. If the resistance is correct re-connect the sensor cables and remove plug ML1.
4. Measure the resistance between pins 9 and 10 of plug ML1. If the resistance is not as given in the table renew the sensor cables.
5. If the resistance is correct re-connect plug ML1 and disconnect cables 212 and 213 from controller terminal plug X02.

6. Measure the resistance between the disconnected cable ends. If the resistance is not as given in the table renew cables 212 and 213 as necessary.
7. If the resistance is correct, renew the controller.

**10. CONTROLLER**

<b>CAUTION</b>	
<ul style="list-style-type: none"> <li>● When working with static sensitive components, ie, circuit cards and memory IC's etc, always take antistatic precautions.</li> </ul>	<ol style="list-style-type: none"> <li>1. Always transport static sensitive components in anti-static bags or containers.</li> <li>2. Never touch the metal pins of electronic IC devices.</li> <li>3. Never place static sensitive components onto a metal surface. Always place directly into an anti-static bag or container.</li> <li>4. Always ensure any body static is discharged before handling static sensitive components by touching an earthed surface at regular intervals.</li> </ol>

Temperature (°C)	Sensor Res. (ohms)	Temperature (°C)	Sensor Res. (ohms)
0	1605	50	2448
5	1678	60	2638
10	1762	70	2844
15	1848	80	3058
20	1927	90	3282
25	2008	100	3520
30	2092	110	3772
40	2263	120	4043

### 10.1 Control Card

The Controller is a single PCB assembly with the digital display segments, LED indicators and keypad switches mounted on the card. The card is fitted with two T3.15A fuses, one connected to the 24Vac power supply input and the other to the 0Vac power supply input. The card is fitted with a pre-formed metallic plate which acts as an earthed shielding against electromagnetic interference and also protects against mechanical damage.

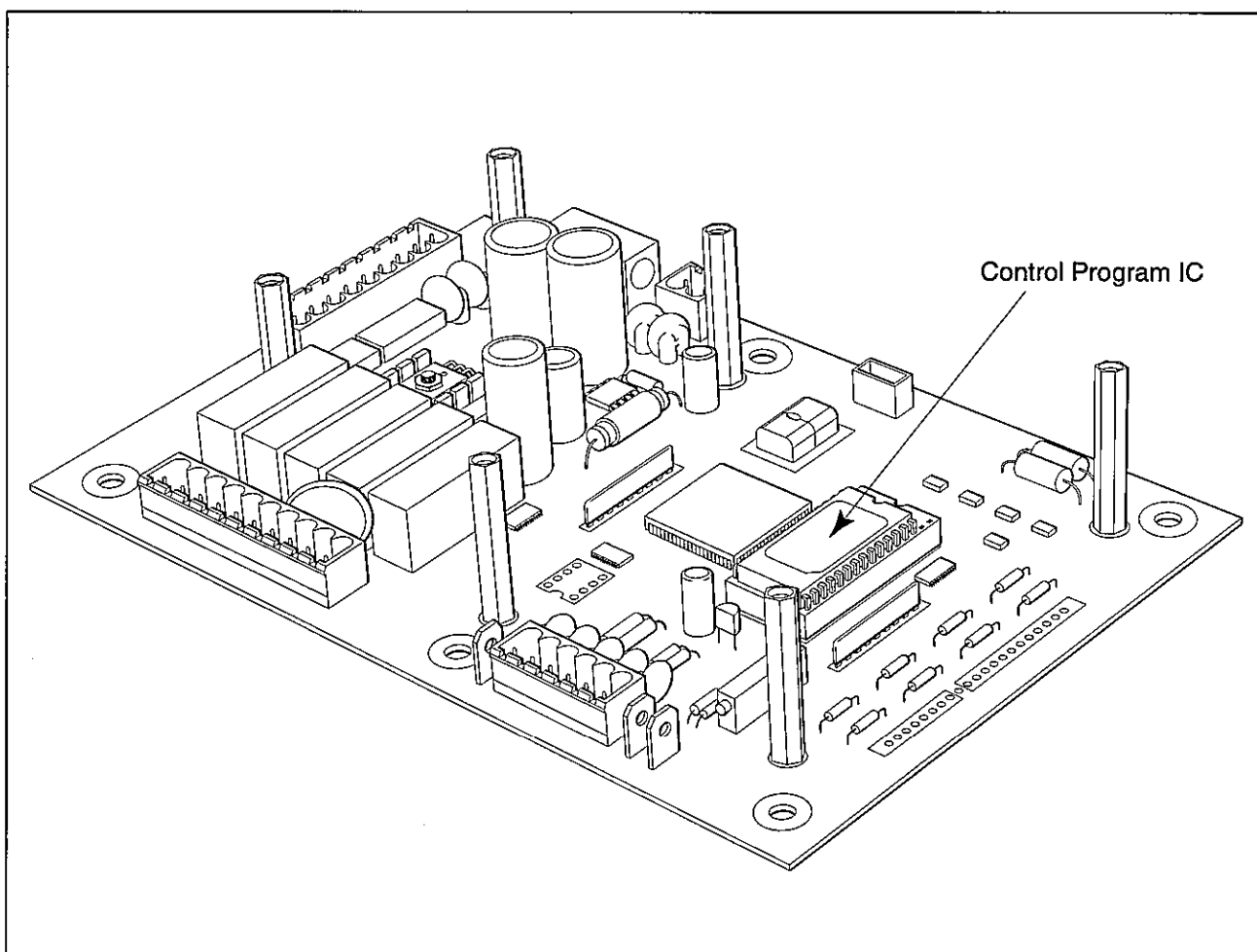
**Note:** Standard IEC127 (5 x 20mm) fuses are readily available in several characteristic types (F3.15A, FF3.15A, T3.15A for example). Only 'T' type fuses must be used.

### 10.2 Control Program IC

The controller runs a program contained in the control program IC. This program determines the operation and function of the controller.

Instructions for renewing the control program IC within a C20606-50 SureScan controller

1. Switch off and isolate the power supply to the compressor.
2. Remove the top canopy panel and the starter area access panel.
3. Remove the six control card protection plate securing screws and remove the protection plate.

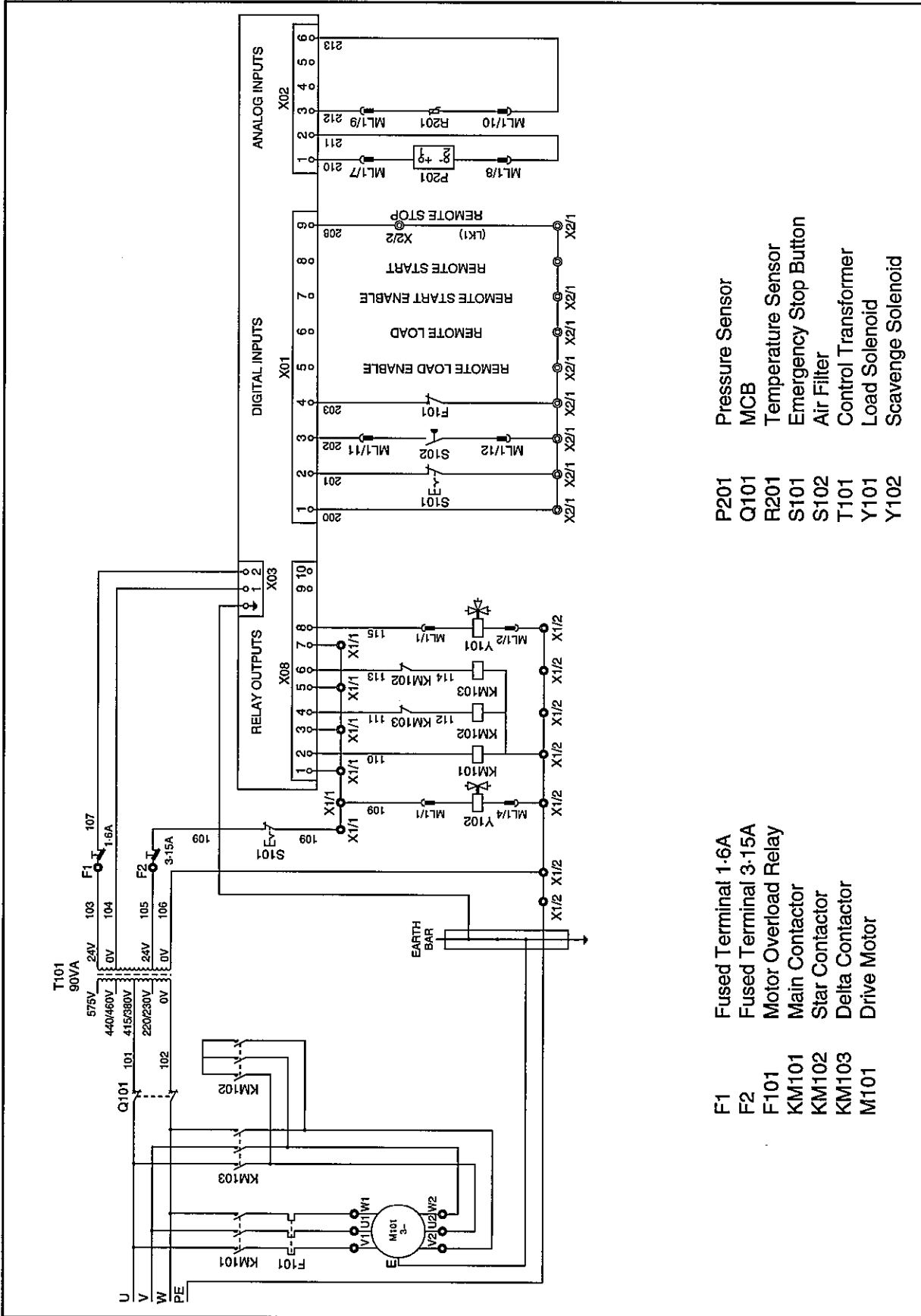


**FIG. 7.11 ARRANGEMENT OF CONTROLLER CARDS**

4. Before removal of the control program IC, make a note, or pencil sketch, of the orientation and position of the IC in its socket. Note the orientation marks on the IC, socket and circuit board. Also note the position of the four unused holes on the IC socket.
5. Using a small screwdriver, or similar tool, carefully remove the control program IC from its socket.
6. Insert the new control program IC. Check the orientation and ensure that each pin enters the socket correctly. (The pins may bend underneath the IC during insertion.)

**Note:** The IC socket has four extra holes which are not used. Ensure none of the control program IC pins are inserted into these holes.

7. Replace and secure the control card protection plate, replace the compressor canopies and test.



- P201 Pressure Sensor
- Q101 MCB
- R201 Temperature Sensor
- S101 Emergency Stop Button
- S102 Air Filter
- T101 Control Transformer
- Y101 Load Solenoid
- Y102 Scavenge Solenoid

- F1 Fused Terminal 1-6A
- F2 Fused Terminal 3-15A
- F101 Motor Overload Relay
- KM101 Main Contactor
- KM102 Star Contactor
- KM103 Delta Contactor
- M101 Drive Motor

FIG. 7.12 ELECTRICAL CONNECTIONS DIAGRAM



---

# CHAPTER

# 8

## DISASSEMBLY & ASSEMBLY

<b>Description</b>	<b>Page</b>
Suction Regulator	1
Remove Suction Regulator	1
Install Suction Regulator	1
Disassemble Suction Regulator	2
Inspect/Replace Worn Parts	3
Assemble Suction Regulator	3
Minimum Pressure Valve	4
Remove Minimum Pressure Valve	
– Models Cyclon 105, 107 and 111	4
Install Minimum Pressure Valve	
– Models Cyclon 105, 107 and 111	4
Disassemble Minimum Pressure Valve	
– Models Cyclon 105, 107 and 111	5
Inspect/Replace Worn Parts	5
Assemble Minimum Pressure Valve	
– Models Cyclon 105, 107 and 111	5
Remove Minimum Pressure Valve	
– Models Cyclon 215, 218 and 222	6
Install Minimum Pressure Valve	
– Models Cyclon 215, 218 and 222	7
Disassemble Minimum Pressure Valve	
– Models Cyclon 215, 218 and 222	7
Inspect/Replace Worn Parts	8
Assemble Minimum Pressure Valve	
– Models Cyclon 215, 218 and 222	8
Oil Drain Valve	9
Remove Oil Drain Valve	9
Install Oil Drain Valve	9
Oil Scavenge Pipe	10
Remove Oil Scavenge Pipe	10
Install Oil Scavenge Pipe	11

*Continued . . .*

---

---

<b>Description</b>	<b>Page</b>
Drive Motor	11
Remove Drive Motor	11
Install Motor	13
Air-End	13
Remove Air-End	13
Install Air-End	14
Remove Air-End Oil Seal	15
Install Air-End Oil Seal	16
Air-End and Motor Pulley	17
Remove Pulley	17
Install Pulley	18
Drive Belt(s)	19
To Adjust The Drive Belt(s):	19
Thermostatic Bypass Valve	19
Remove Thermostatic Bypass Valve	19
Install Thermostatic Bypass Valve	19
Oil Cooler	20
Remove Oil Cooler	20
Clean Oil Cooler	20
Install Oil Cooler	20
Air Cooler	21
Remove Air Cooler	21
Clean Air Cooler	21
Install Air Cooler	21

---

## DISASSEMBLY & ASSEMBLY



**WARNING**



- Refer to the safety procedures before carrying out any disassembly or assembly of the compressor unit.

- Lethal voltages are used in this equipment. Use extreme caution when carrying out electrical checks. Isolate the power supply before starting any maintenance work.

### 1. SUCTION REGULATOR

#### 1.1 Remove Suction Regulator

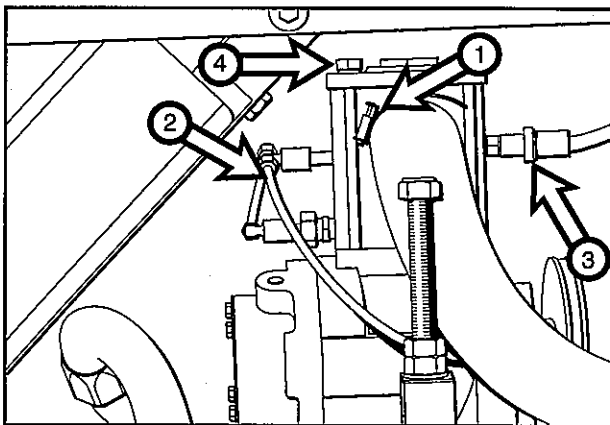
1. Remove roof panel from the compressor unit.
2. Slacken clip (1) securing the air intake pipe to the suction regulator.
3. Disconnect the regulation air line (2) from the suction regulator.
4. Disconnect the electrical wiring (3) from the terminals on the air filter switch.
5. Release the four bolts (4) and spring washers securing the regulator to the air-end.

6. Carefully lift the suction regulator out of the unit.
7. Cover the air-end opening with tape to prevent the entry of dirt.

#### 1.2 Install Suction Regulator

Installation of the suction regulator is a reversal of the removal procedure. Install a new joint, supplied in the repair kit between the base of the suction regulator and the air-end inlet.

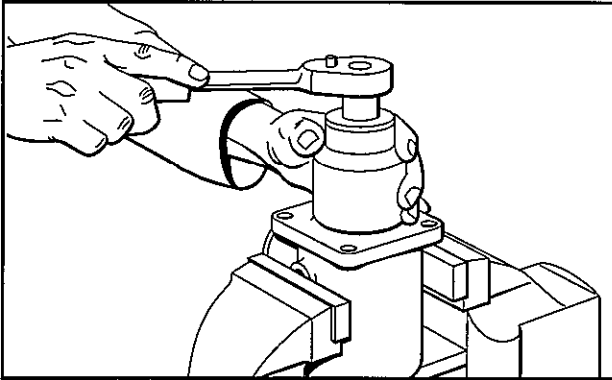
**Note:** Tighten the four bolts to a torque of 30Nm. Do **not** overtighten.



### 1.3 Disassemble Suction Regulator

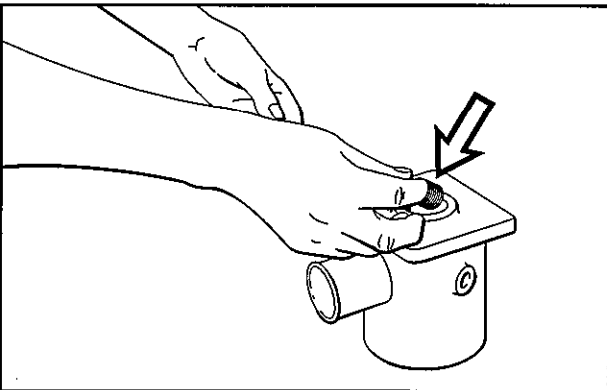
**CAUTION:** Do not attempt to dismantle suction regulator before removal from air-end.

1. Remove the suction regulator from the air-end. Refer to 1.1 'Remove Suction Regulator' in this chapter.
2. Secure the suction regulator in a suitable vice. Remove cap.

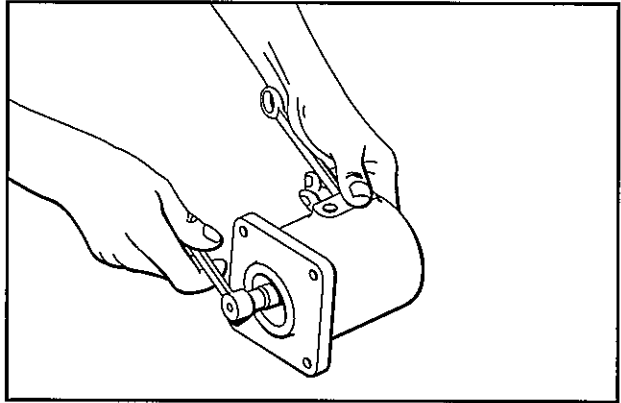


**Note:** On compressor models Cyclon 215, 218 and 222 the cap is fitted to the regulator body by four capscrews and spring washers. A joint is also fitted between the cap and regulator body.

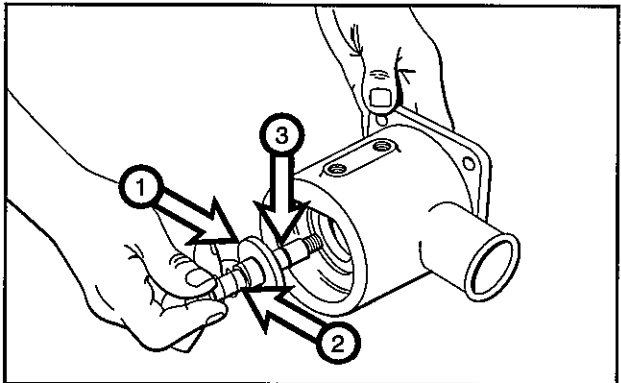
3. Remove the piston spring by hand from the top of the suction regulator body.



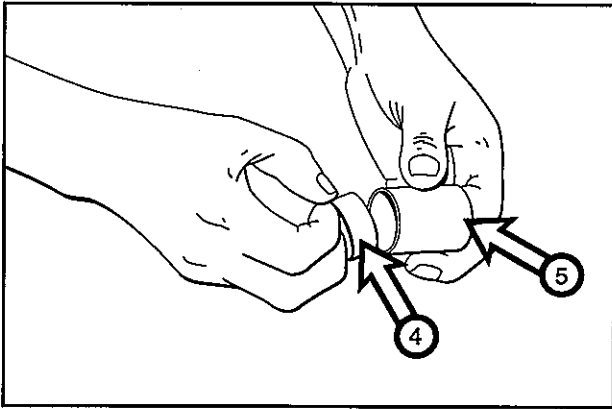
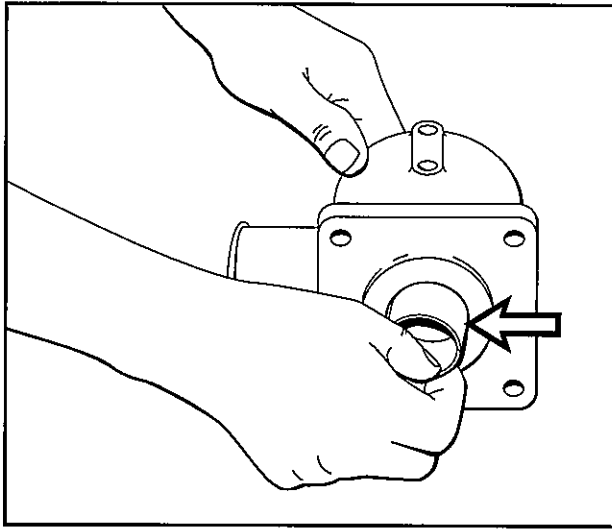
4. Remove the suction regulator from the vice. Secure the valve stem from underneath and undo the valve stem locknut from the top.



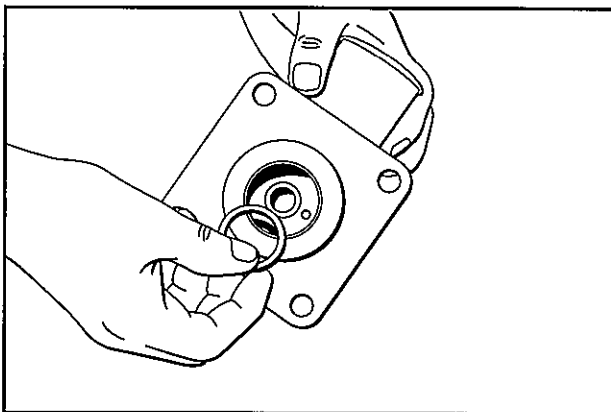
5. Remove and discard the locknut and washer.
6. Remove the remaining valve stem assembly from the bottom. Slide the valve (1) and spring (2) from the valve stem. Remove and discard 'O' ring seal (3).



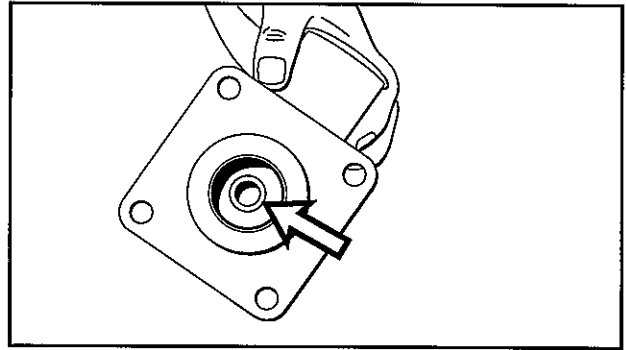
7. Remove the piston and cylinder from the top of the regulator body. Slide the piston (4) from the cylinder (5) and discard.



8. Remove and discard the joint from the regulator body.



9. Using suitable equipment press the bush from the regulator body and discard.



#### 1.4 Inspect/Replace Worn Parts

Clean and inspect all parts for wear or damage. Inspect the valve stem for scratches or burrs. Inspect the regulator body for any scoring to the bore. Change all worn or damaged components.

#### 1.5 Assemble Suction Regulator

##### Parts Required:

Suction Regulator Kit.

1. When assembling the suction regulator use the new parts supplied in the kit to ensure correct operation.
2. Press the new bush, supplied in the kit into the regulator body.
3. Slide the valve spring and valve onto the stem. Apply a coating of a silicon based grease to the new 'O' ring seal supplied in the kit and fit it into the groove on the valve stem.

**Note:** The valve spring should locate over the smaller diameter of the valve.

4. Fit the valve stem assembly up through the suction regulator body locating the stem into the bore of the bush.

**Note:** Ensure the valve is seated correctly inside the regulator body.

5. Apply a light coating of grease to the new piston supplied in the kit. Fit the piston to the top of the stem and secure using the new washer and locknut supplied in the repair kit.

*Cyclon 105, 107 and 111:*

Tighten the locknut to a torque setting of 17 Nm.

*Cyclon 215, 218 and 222:*

Tighten the lock nut to a torque setting of 60Nm.

6. Fit the new joint supplied in the repair kit to the regulator body. Apply a light coating of grease to the bore of the cylinder and place it on top of the joint.

7. Fit the piston spring to the top of the piston.

8. *Cyclon 105, 107 and 111:*  
Install the regulator cap and tighten to a torque setting of 41Nm.

*Cyclon 215, 218 and 222:*

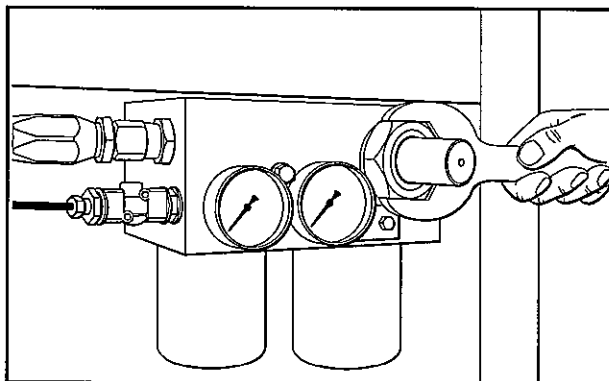
Install the regulator cover and new joint supplied in the repair kit and secure with the four capscrews and washers. Tighten the screws to a torque setting of 10 Nm.

9. Install the suction regulator. Refer to 1.2 'Install Suction Regulator' in this chapter of the Manual.

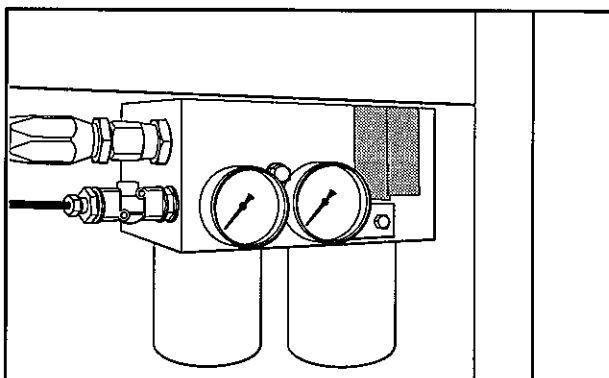
## 2. MINIMUM PRESSURE VALVE

### 2.1 Remove Minimum Pressure Valve – Models Cyclon 105, 107 and 111

1. Remove the service panel from the front of the compressor unit.
2. Fully unscrew the valve body and remove the minimum pressure valve assembly from the manifold block.



3. Cover the hole in the manifold block to prevent contamination.

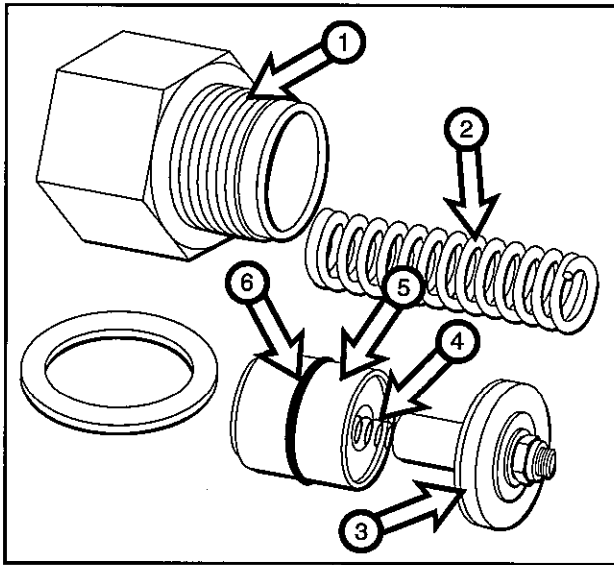


### 2.2 Install Minimum Pressure Valve – Models Cyclon 105, 107 and 111

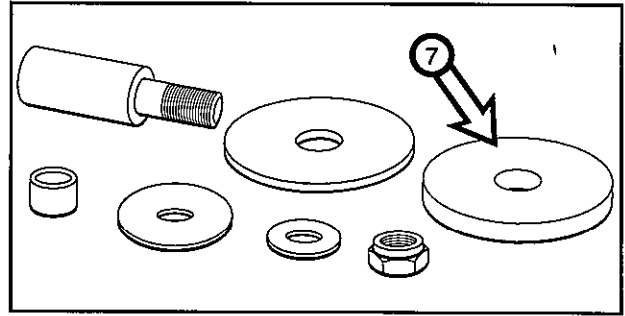
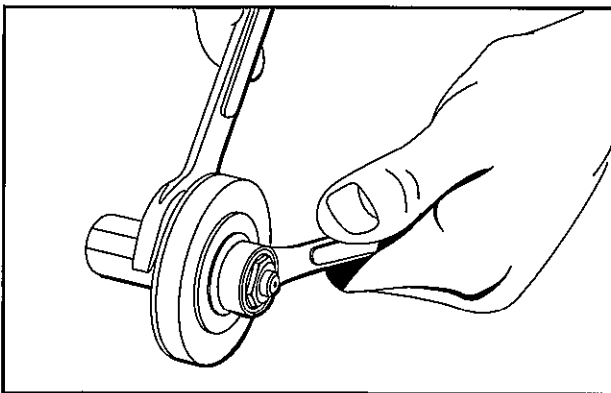
Installation is a reversal of the removal procedure. Fit a new sealing washer supplied in the repair kit between the minimum pressure valve assembly and manifold block.

**2.3 Disassemble Minimum Pressure Valve – Models Cyclon 105, 107 and 111**

1. Remove the minimum pressure valve. Refer to 2.1 'Remove Minimum Pressure Valve'.
2. Remove the valve body (1) and piston spring (2).
3. Remove the valve assembly (3), small spring (4) and piston (5). Remove and discard the 'O' ring seal (6) from the outer groove of the piston.



4. Disassemble the valve assembly and discard the valve head (7).



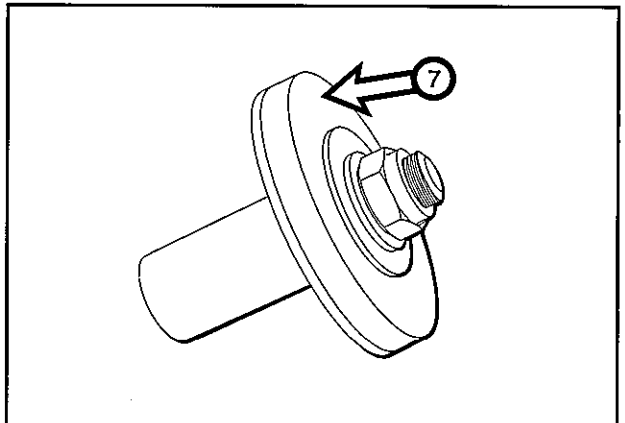
**2.4 Inspect/Replace Worn Parts**

Clean and inspect all the parts for wear or damage. Inspect the surface of the piston for scratches. Clean and inspect the valve body for any scoring or corrosion inside the bore. If the bore of the valve body is corroded, remove all traces of corrosion using a fine emery paper until the surface is smooth and clean. Apply a light coating of a silicone based grease to the bore of the valve body before reassembling the valve. Change all worn or damaged components for new items.

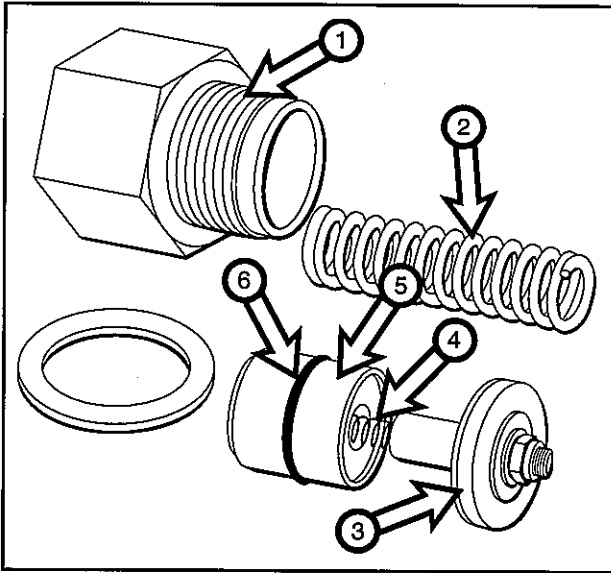
**2.5 Assemble Minimum Pressure Valve – Models Cyclon 105, 107 and 111**

**Parts Required:** Minimum Pressure Valve Kit.

1. Assemble the valve using a new valve head (7), washer and locknut supplied in the repair kit.



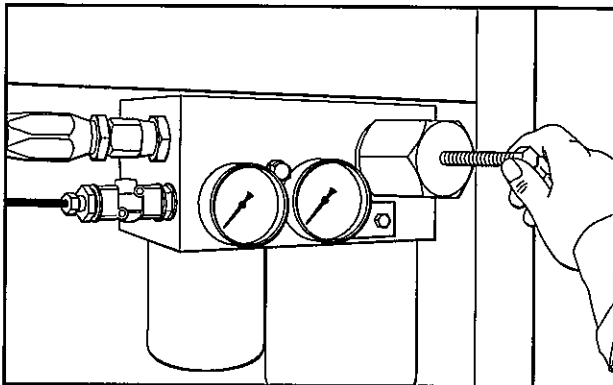
2. Fit a new 'O' ring seal (6) supplied in the repair kit to the outer groove of the piston (5).



3. Insert the small spring (4) into the guide pin and insert the valve assembly into the bore of the piston.
4. Insert piston spring (2) into the valve body (1) followed by the piston and valve assembly.
5. Install the valve. Refer to 2.2 'Install Minimum Pressure Valve' in this chapter.

### 2.6 Remove Minimum Pressure Valve – Models Cyclon 215, 218 and 222

1. Remove the front service panel.
2. Screw the bolt, supplied with the repair kit, through the valve body into the piston.

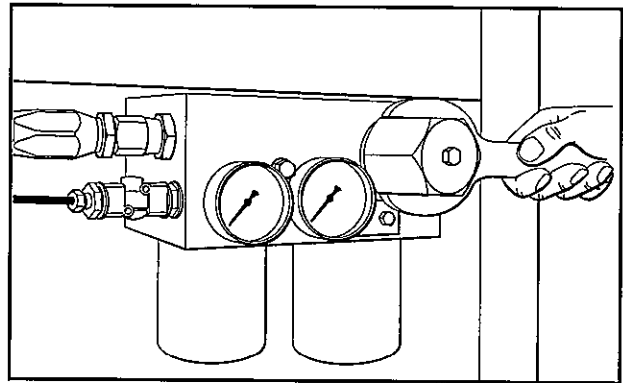


### WARNING

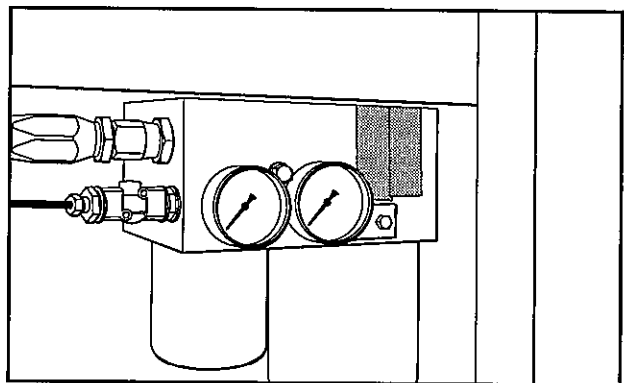


- Do not attempt to remove the valve assembly from the manifold block before taking up the compression on the piston spring. Failure to heed this warning could result in personal injury.

3. Fully unscrew the valve body and remove the minimum pressure valve assembly from the manifold block.

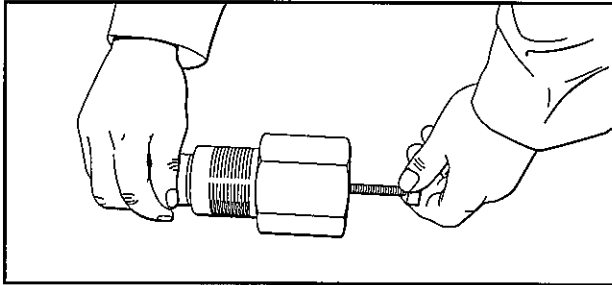


4. Unscrew the bolt carefully to release the compression on the piston spring.
5. Cover the hole in the manifold block to prevent contamination.

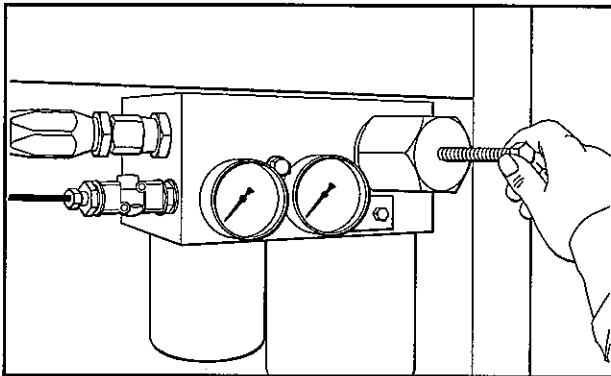


**2.7 Install Minimum Pressure Valve – Models Cyclon 215, 218 and 222**

1. Push the piston towards the valve body and screw the bolt supplied in the repair kit through the valve body into the piston. Turn the bolt to draw the piston into the valve body.



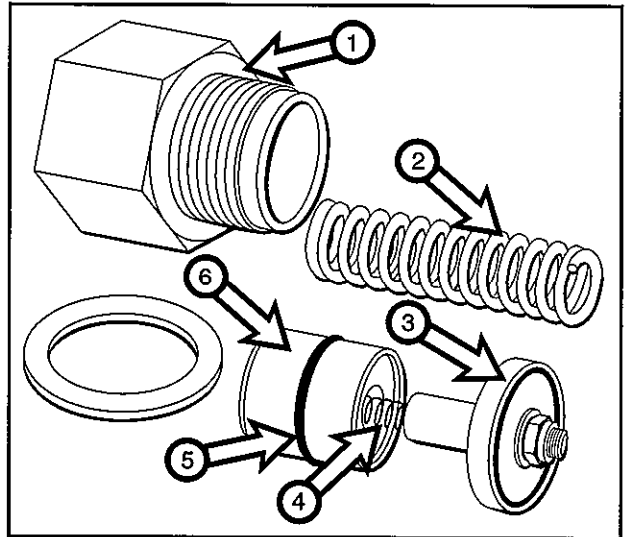
2. Fit the minimum pressure valve assembly into the manifold block using a new sealing washer supplied in the repair kit.
3. Unscrew and remove the bolt from the valve body.



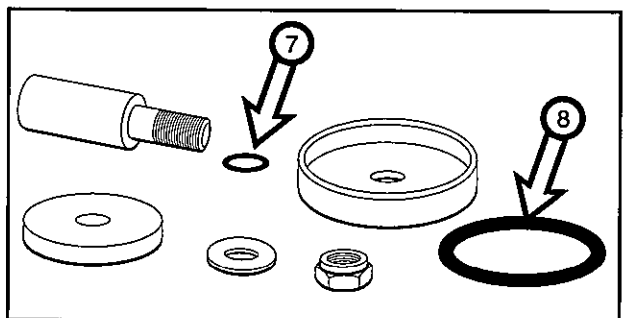
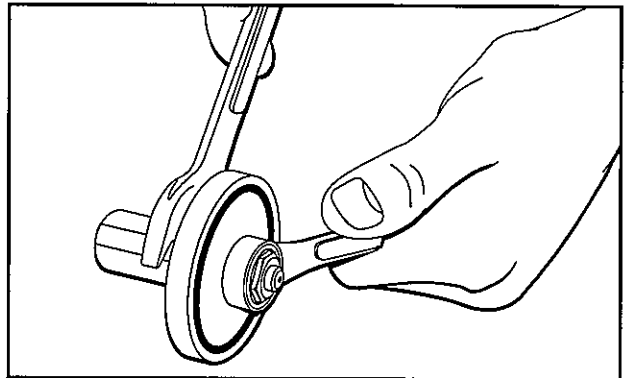
**2.8 Disassemble Minimum Pressure Valve – Models Cyclon 215, 218 and 222**

1. Remove the minimum pressure valve. Refer to 2.6 'Remove Minimum Pressure Valve'.

2. Remove the valve body (1) and piston spring (2).



3. Remove the valve assembly (3), small spring (4) and piston (6). Remove and discard the 'O' ring seal (5) from the outer groove of the piston.
4. Disassemble the valve assembly and discard the 'O' ring seals (7) and (8).



### 2.9 Inspect/Replace Worn Parts

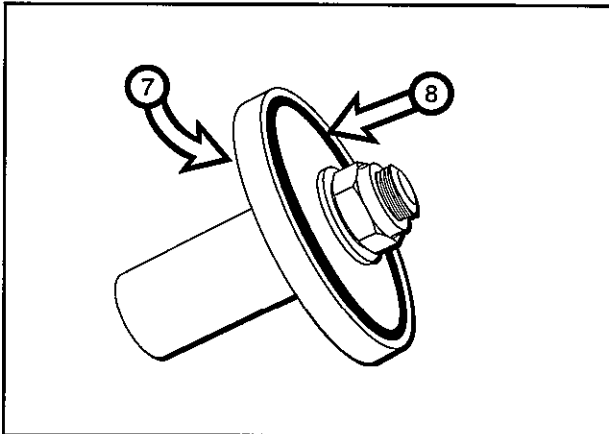
Clean and inspect all the parts for wear or damage. Inspect the surface of the piston for scratches. Clean and inspect the valve body for any scoring or corrosion inside the bore. If the bore of the valve body is corroded, remove all traces of corrosion using a fine emery paper until the surface is smooth and clean. Apply a light coating of a silicone based grease to the bore of the valve body before reassembling the valve. Change all worn or damaged components for new items.

### 2.10 Assemble Minimum Pressure Valve – Models Cyclon 215, 218 and 222

#### Parts Required:

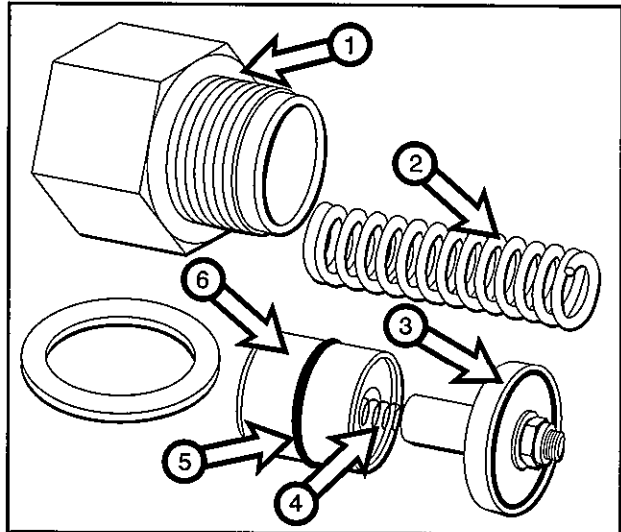
Minimum Pressure Valve Kit.

1. Fit new 'O' ring seals (7) and (8), supplied in the repair kit, to the guide pin and valve head.



2. Assemble the valve using a new washer and locknut supplied in the repair kit.



3. Fit a new 'O' ring seal (5) supplied in the repair kit to the outer groove of the piston (6).



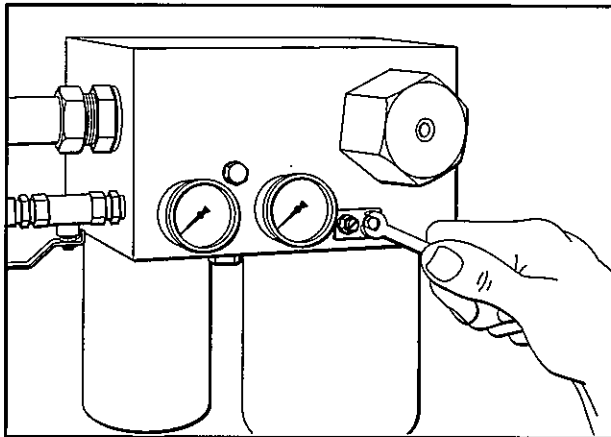
4. Insert the small spring (4) into the guide pin and insert the valve assembly (3) into the bore of the piston.
5. Insert piston spring (2) into the valve body (1) followed by the piston and valve assembly.
6. Install the valve. Refer to 2.7 'Install Minimum Pressure Valve' in this chapter.

### 3. OIL DRAIN VALVE

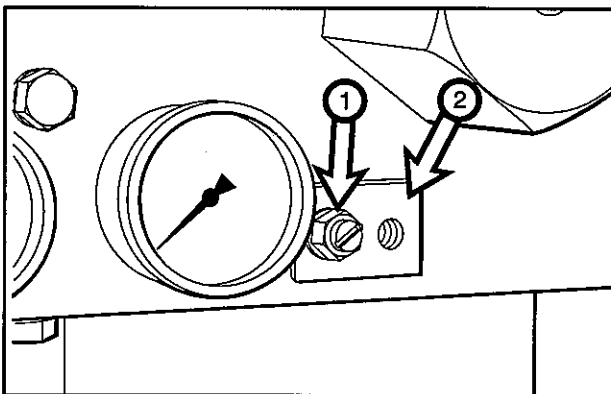
#### 3.1 Remove Oil Drain Valve

	<b>WARNING</b>	
<ul style="list-style-type: none"> <li>● Ensure all air pressure is released from the system in accordance with 'Dismantling Precautions' in Chapter 1.</li> </ul>		

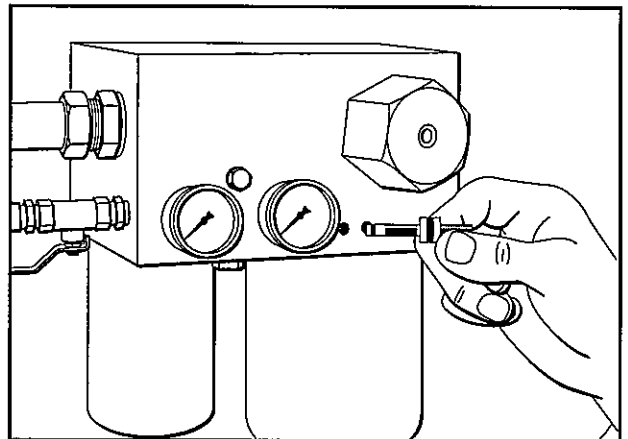
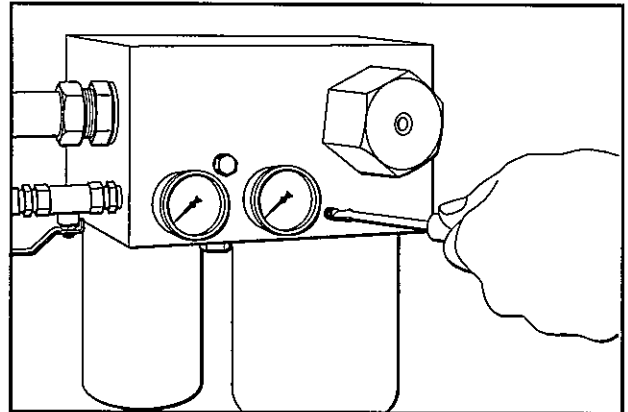
1. Remove the service panel from the front of the compressor unit to gain access to the oil drain valve which is located on the front of the manifold block.
2. Close the control air isolating valve (painted red and fitted to the manifold block).
3. Remove the screw and washers securing the oil drain valve fixing plate to the manifold block.



4. Undo and remove the locknut (1) and fixing plate (2).



5. Unscrew the oil drain valve from the manifold block.





#### 3.2 Install Oil Drain Valve

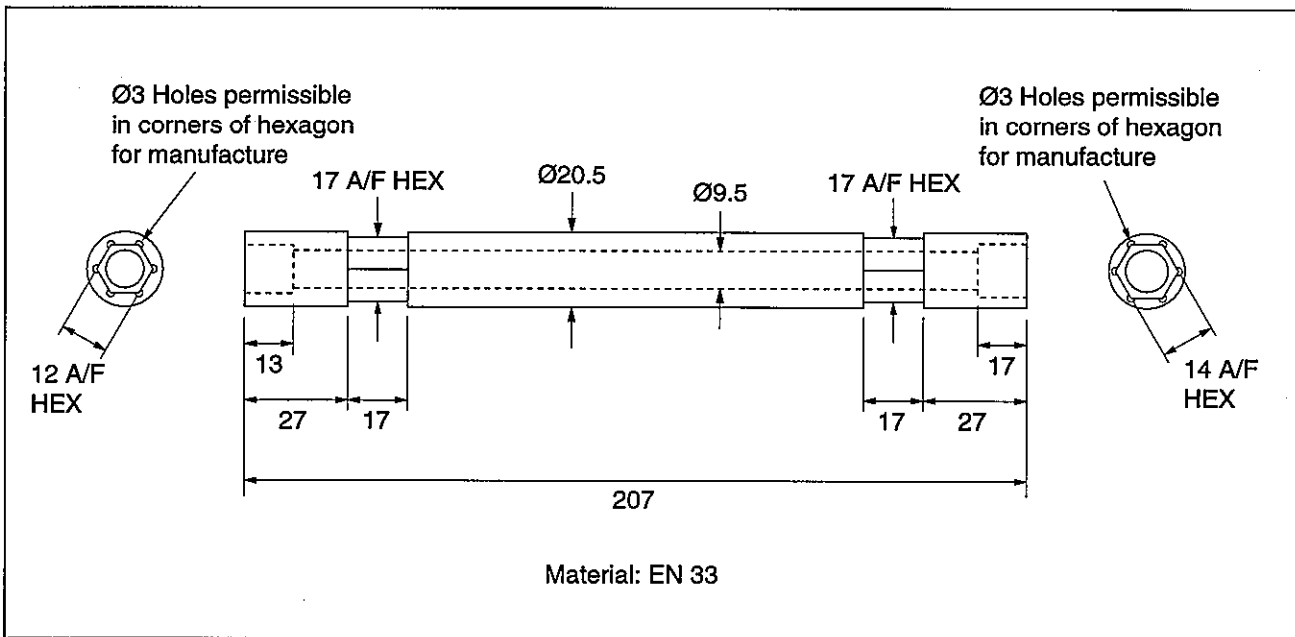
Installation is a reversal of the removal procedure. Fit new 'O' ring seals to the valve spindle. Ensure that the oil drain valve is screwed into the manifold block as far as it will go.

#### 4. OIL SCAVENGE PIPE

##### 4.1 Remove Oil Scavenge Pipe

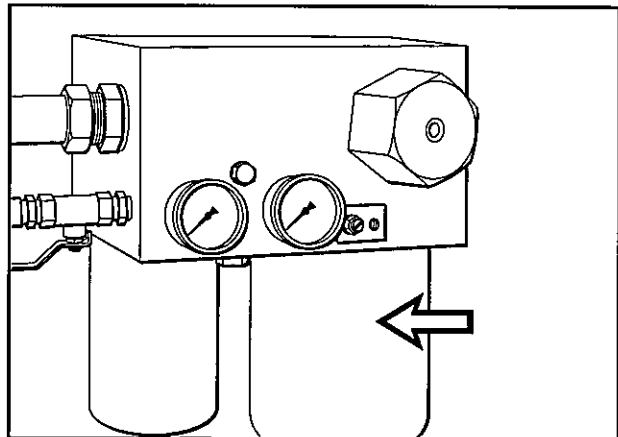
	<b>WARNING</b>	
<ul style="list-style-type: none"><li>● Ensure all air pressure is released from the system in accordance with 'Dismantling Precautions' in Chapter 1.</li></ul>		

**Tooling Required:** Scavenge Coupling Tool

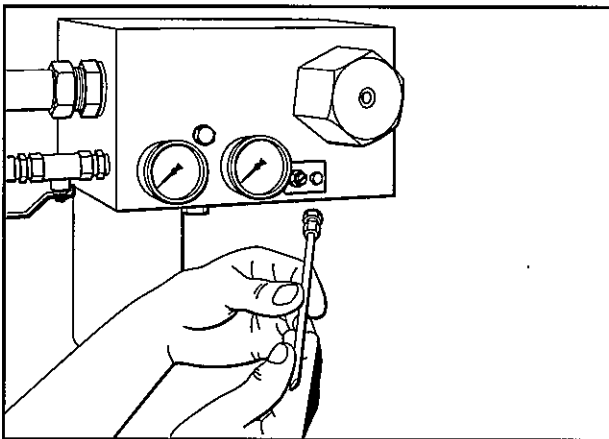
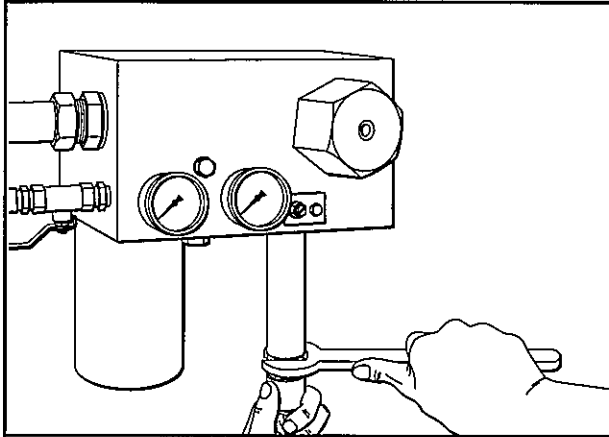


**FIG. 8.1 SCAVENGE COUPLING TOOL**

1. Remove the service panel from the front of the compressor unit to gain access to the manifold block.
2. Close the control air isolating valve (painted red and fitted to the manifold block).
3. Unscrew and remove the oil separator filter.



4. Fit the scavenge coupling tool (Fig 8.1) over the oil scavenge pipe. Undo and remove the coupling and oil scavenge pipe assembly from the manifold block.



#### 4.2 Install Oil Scavenge Pipe

Installation is a reversal of the removal procedure. Fit a new scavenge pipe and coupling to the manifold block.

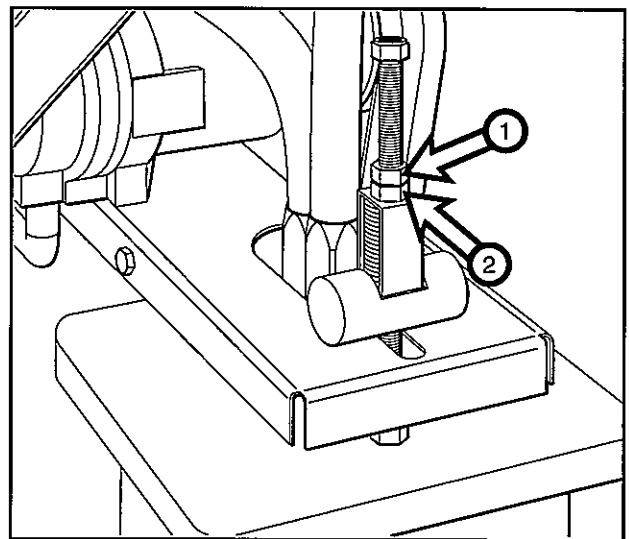
**Note:** Fit the scavenge pipe to the coupling before installing it into the manifold block.

## 5. DRIVE MOTOR

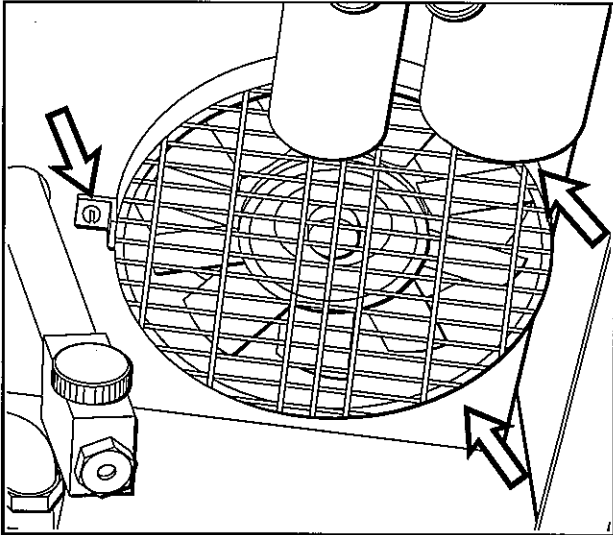
### 5.1 Remove Drive Motor

<span style="font-weight: bold; font-size: 1.2em; margin: 0 10px;">WARNING</span>
<ul style="list-style-type: none"> <li>● Ensure electrical power is isolated in accordance with 'Dismantling Precautions' in Chapter 1.</li> </ul>

1. Remove the front service panel and the cooler side panel from the compressor unit.
2. Release the lock nut (1) and slacken nut (2) on the belt tensioning device to remove tension from the drive belts.



3. Remove the drive belts.
4. Undo and remove the three screws securing the fan cowl and guard to the bulkhead panel. Remove the fan cowl and guard to gain access to the fan.

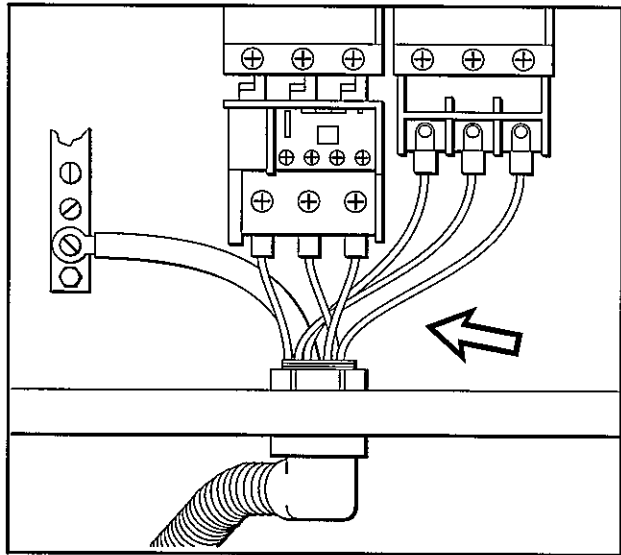


5. *Cyclon 105, 107, 111, 215 & 218:*  
Undo and remove the 3 grub screws securing the fan to the motor shaft. Remove the fan to prevent it from being damaged when the motor is removed.

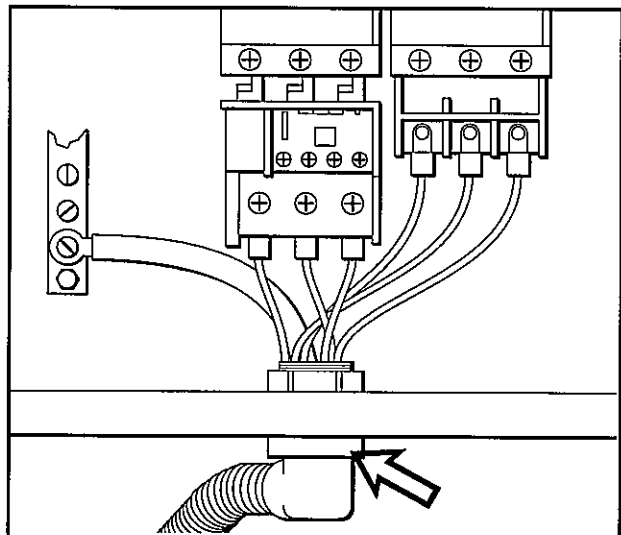
*Cyclon 222:*

Undo and remove the screw fitted into the end of the motor shaft (Cyclon 222). Remove the fan to prevent it from being damaged when the motor is removed.

6. Disconnect the motor cables and earth from terminals in the starter box.

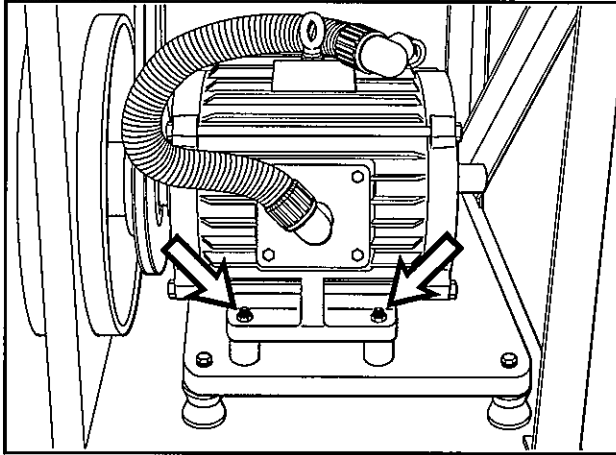


7. Disconnect the motor conduit and pull cable harness through back of starter box.



8. *Cyclon 105, 107, 215 & 218:*  
Remove the four nuts securing the motor to the studs fitted to the mounting plate.

*Cyclon 111 & 222:*  
Remove four bolts securing motor to mounting plate.



9. Lift or slide motor clear of unit.

**Note:** Approximate weight of motor Type IP55

Cyclon 105 & 107	= 105 kg
Cyclon 111	= 118 kg
Cyclon 215	= 120 kg
Cyclon 218	= 138 kg
Cyclon 222	= 184 kg

## 5.2 Install Motor

Installation is a reversal of the removal procedure.

**Note 1:** To adjust the tension of the drive belt(s) refer to 8.1 'To Adjust the Tension of the Drive Belt(s)' in this chapter.

**Note 2:** Ensure that the motor cables are connected exactly as shown in the wiring diagram. Refer to Chapter 7.

## 5.3 Disassemble/Assemble Drive Motor – IP55 (T.E.F.V)

Any disassembly/assembly of the drive motor should be referred to CompAir BroomWade.

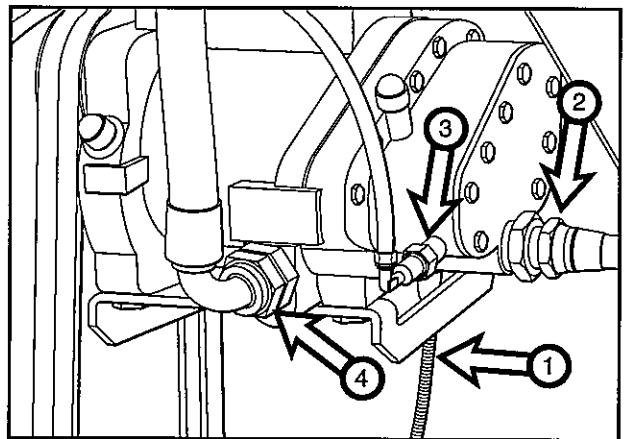
## 6. AIR-END

### 6.1 Remove Air-End

1. Remove both side panels and the roof panel from the compressor unit.
2. Drain oil from the compressor. Refer to 4.8.4 'To Drain the Oil' in Chapter 6.
3. Remove the suction regulator. Refer to 1.1 'Remove Suction Regulator' in this chapter.
4. *Cyclon 105, 107 and 111:*  
Disconnect terminals from thermistor probe (1).

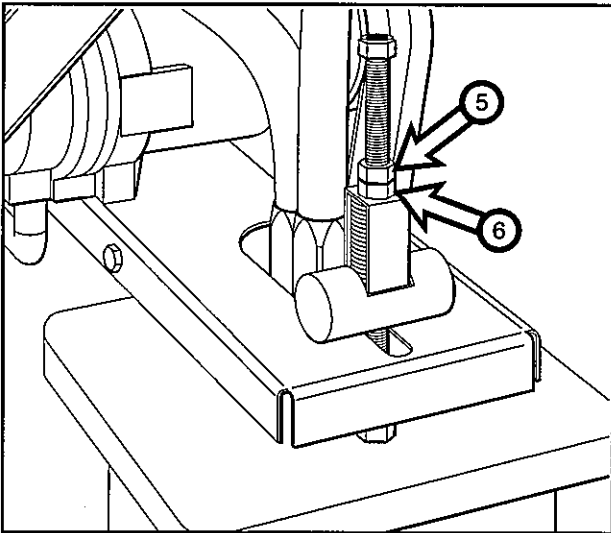
**Note:** On compressor models Cyclon 215, 218 and 222 the thermistor probe is fitted to the air-end discharge pipe.

5. Unscrew and remove the coupling (2) between the separator vessel and air-end discharge, the scavenge oil pipe (3) and the oil supply pipe (4). Note that oil may still be present in the pipes.

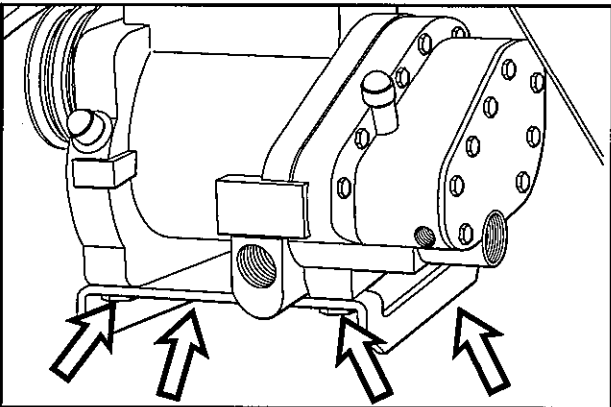


**Note:** On compressor models Cyclon 215, 218 and 222 the air-end discharge pipe is fitted to the under side of the air-end.

6. Release the lock nut (5) and slacken nut (6) on the belt tensioning device to remove tension from the drive belts.



7. Remove the drive belts.
8. Remove the four bolts securing the air-end to the mounting plate.



9. Lift the air-end clear of the unit.

**Note:** Approximate weight of air-end  
Cyclon 1 = 24 kg  
Cyclon 2 = 44 kg

## 6.2 Install Air-End

Installation is a reversal of the removal procedure.

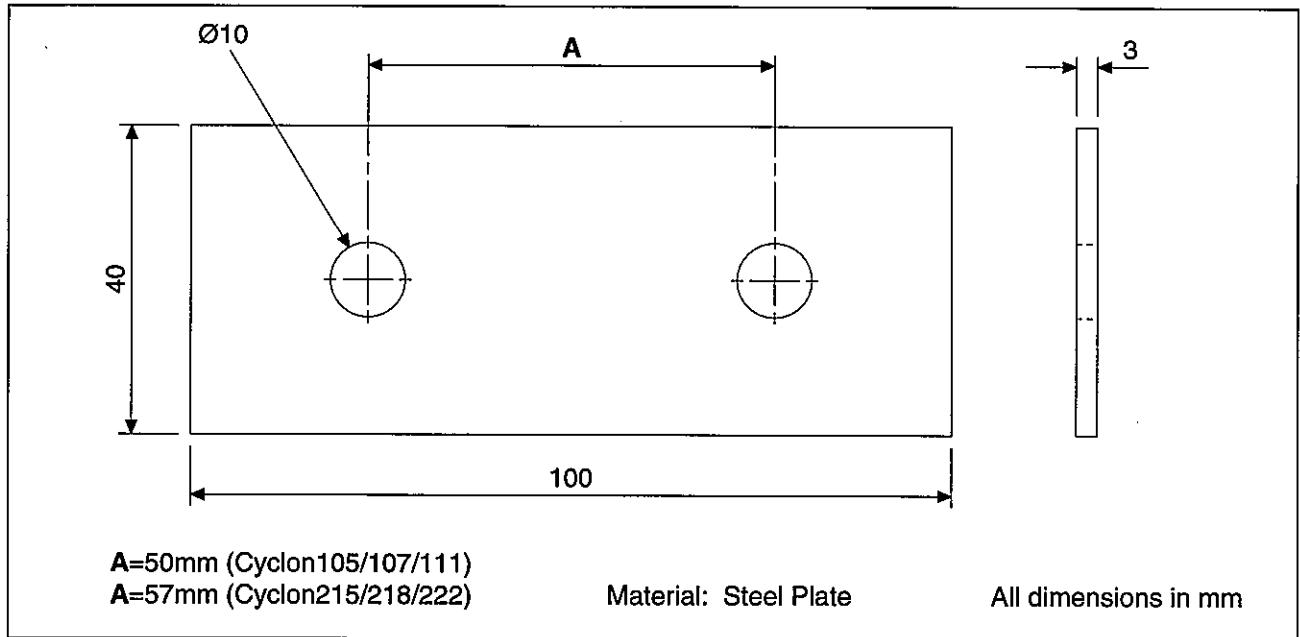
**Note 1:** Place a straight edge tool across the pulleys. Ensure that they are aligned to a tolerance of  $\pm 2$ mm.

To adjust the alignment of the pulleys, undo the four screws securing the air-end to the mounting plate. Adjust the position of the air-end/pulley assembly. Check the alignment and tighten the screws.

**Note 2:** To adjust the tension of the drive belt(s) refer to 8.1 'To Adjust the Tension of the Drive Belt(s)' in this chapter.

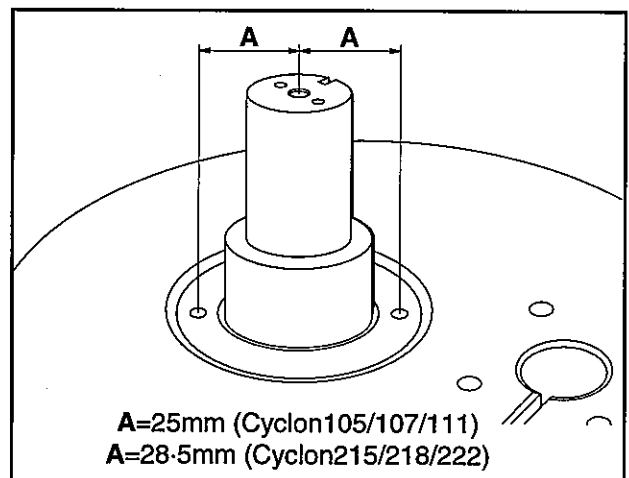
### 6.3 Remove Air-End Oil Seal

**Tooling Required:** Oil Seal Removal Plate,  
two Screws 95018-176, two Washers A3753-3



**FIG. 8.2 AIR-END OIL SEAL REMOVAL PLATE**

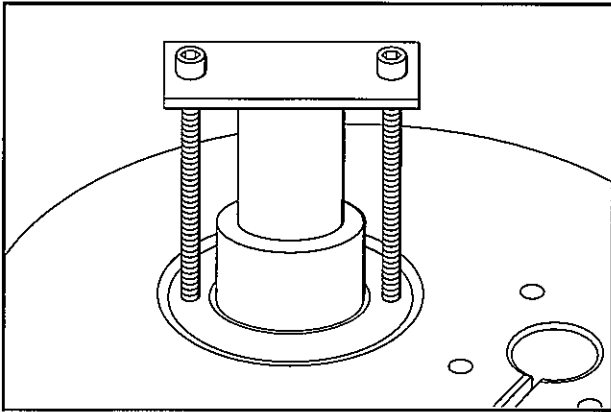
1. Remove the air-end. Refer to 6.1 'Remove Air-End' in this chapter.
2. Remove the air-end pulley. Refer to 7.1 'Remove Pulley' in this chapter.
3. Remove the oil seal retaining plate.
4. Drill two opposite 5mm diameter holes in oil seal at a radius of 25mm (Cyclon 105, 107 and 111), 28.5mm (Cyclon 215, 218 and 222) from the mid point.



**CAUTION:** Ensure that the air-end bearing is not damaged during the drilling operation.

5. Tap both holes M6.

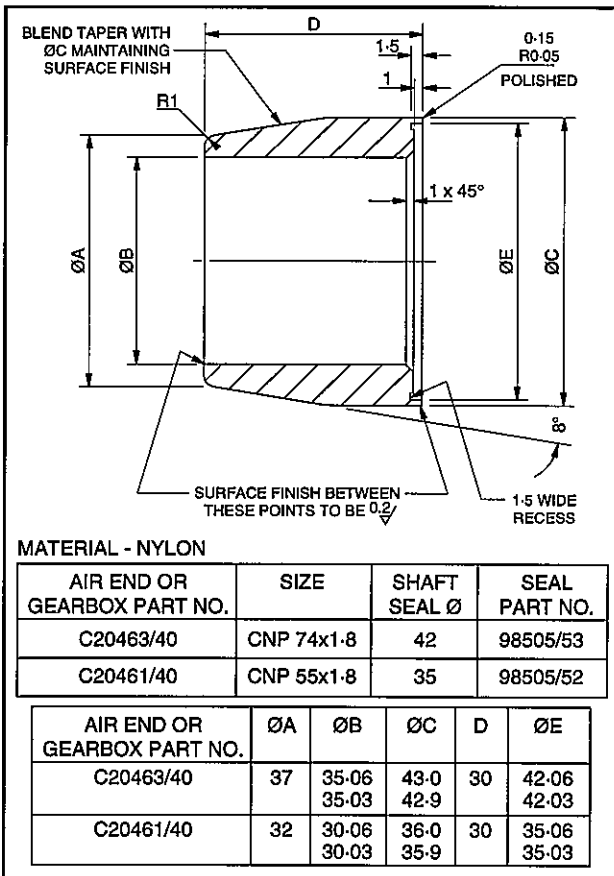
- Fit the removal tool as shown in the illustration below.



- Turn both screws together applying equal force to draw the seal from the housing.

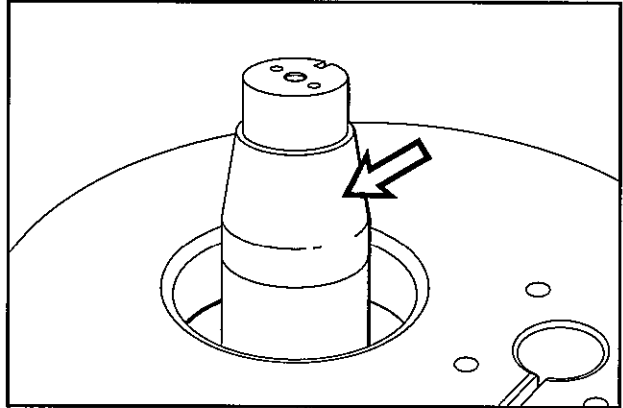
#### 6.4 Install Air-End Oil Seal

**Tooling Required:** Air-End Oil Seal Installation Sleeve

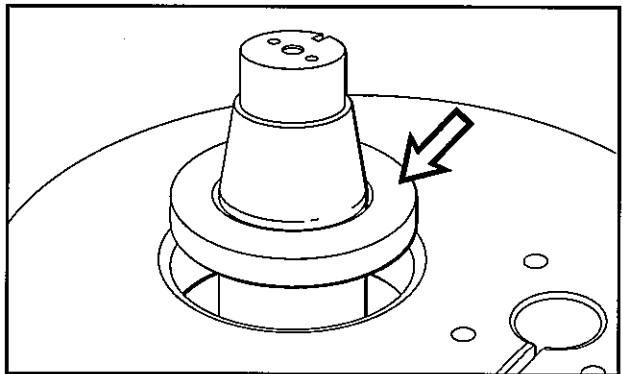


**FIG. 8.3 AIR-END OIL SEAL INSTALLATION SLEEVE**

- Ensure that the air-end bearing is undamaged and that all debris has been removed from the housing before installing a new oil seal.
- Place the oil seal installation sleeve onto the rotor shaft. The sleeve should fit against the lip on the rotor shaft.



- Fit the new oil seal over the sleeve.



- Press the oil seal carefully over the sleeve and into the housing.

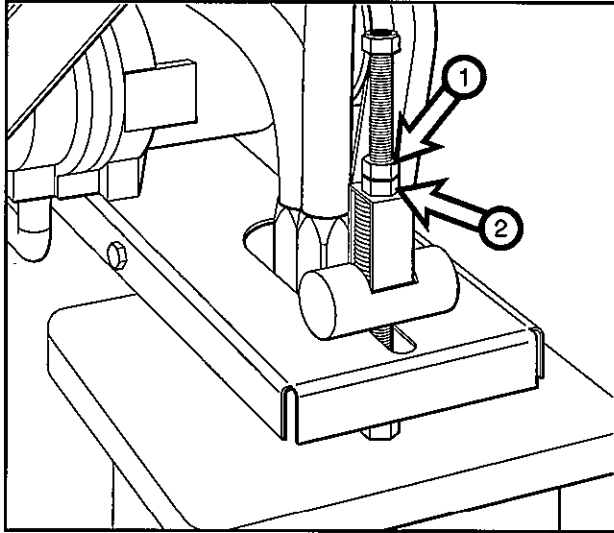
**Note:** Ensure that the oil seal is flush with the face of the housing.

- Remove the installation sleeve and re-fit the oil seal retaining plate.
- Install pulley. Refer to 7.2 'Install Pulley' in this chapter.
- Install air-end. Refer to 6.2 'Install Air-End' in this chapter.

## 7. AIR-END AND MOTOR PULLEY

### 7.1 Remove Pulley

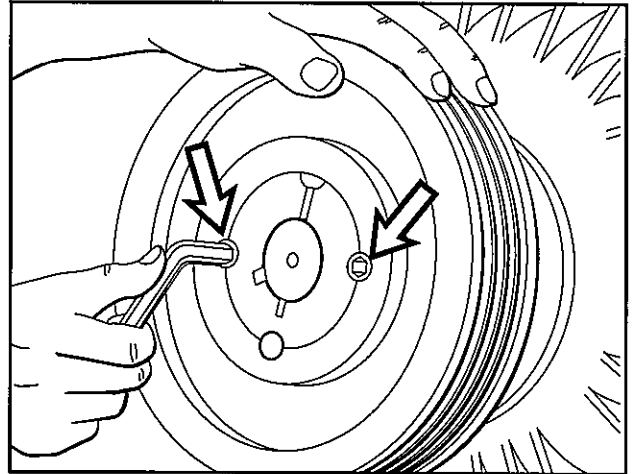
1. Release the lock nut (1) and slacken nut (2) on the belt tensioning device to remove tension from the drive belts.



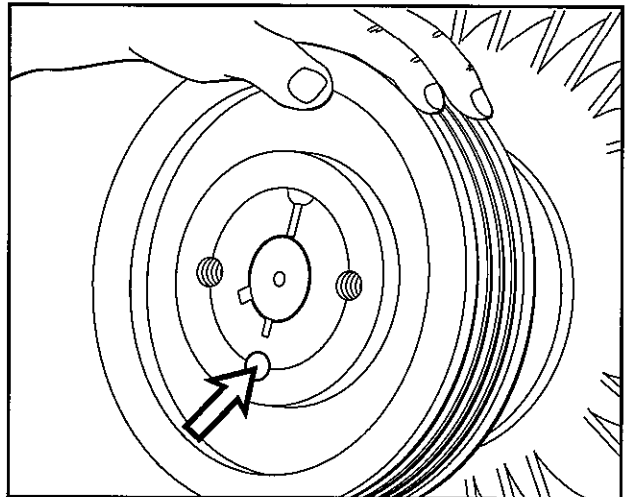
2. Remove the belts from the drive.
3. It may be necessary to remove the air-end (depending on compressor model) to gain access to the air-end pulley. Refer to 6.1 'Remove Air-End' in this chapter.

Remove the fan cowl, guard and fan to gain access to the motor pulley. The fan cowl and guard are fitted to the bulkhead panel by three screws. The fan is secured to the motor shaft by three grub screws (Cyclon 105-218) or a screw fitted into the end of the motor shaft (Cyclon 222).

4. Remove the two grub screws securing the pulley and bush assembly to the shaft.



5. Use one of the screws in the jacking off hole and tighten to release the taper bush from the pulley.

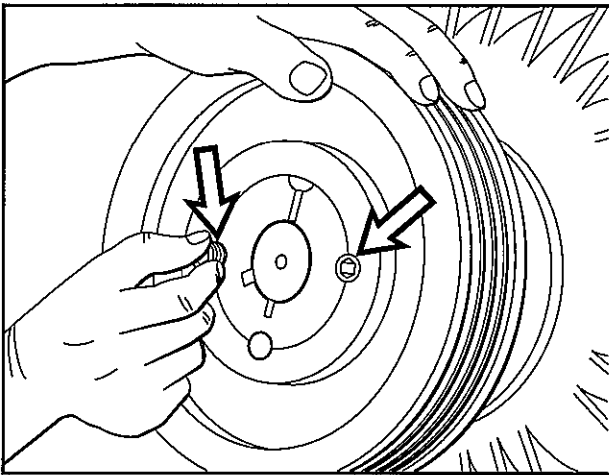


6. Remove the pulley, bush and key from the shaft.

**Note:** When removing the air-end pulley, check the number of spacers fitted to the air-end shaft behind the pulley. Do **not** discard.

## 7.2 Install Pulley

1. Ensure that the mating surfaces of the bush and pulley are clean and free from oil or dirt. Insert the bush in the pulley so that the holes line up.
2. Place the two grub screws loosely into the opposite threaded holes.
3. Before installing the air-end pulley, ensure that the same number of spacers are fitted to the air-end shaft.



4. Clean the shaft and fit the key followed by the pulley and bush assembly. Ensure the pulley is either located against the shoulder on the motor shaft or against the face of the spacers on the air-end shaft.

**Note:** One spacer is fitted to the motor shaft on Cyclon 222 only.

5. Tighten the screws gradually and alternately.
6. If the air-end was removed, re-install the air-end. Refer to 1.2 'Install Air-End' in this chapter.

Re-fit the motor fan, cowl and guard.

7. Place a straight edge tool across the pulleys. Ensure that they are aligned to a tolerance of  $\pm 2\text{mm}$ .

To adjust the alignment of the pulleys, undo the four screws securing the air-end to the mounting plate. Adjust the position of the air-end/pulley assembly. Check the alignment and tighten the screws.

8. Re-fit the drive belts.
9. Adjust the tension of the drive belt(s). Refer to 8.1 'To Adjust the Tension of the Drive Belt(s)' in this chapter.
10. When the compressor has reached normal operating temperature retighten the bolts.

## 8 DRIVE BELT(S)

### 8.1 To Adjust the Tension of the Drive Belt(s):

1. Release the 1/4 turn fasteners and remove the LH side panel.
2. Loosen the lock nut (1) and turn the adjuster nut (2) clockwise until the adjuster (3) contacts the spring retainer (4).
3. Screw the adjuster nut back one turn and tighten the lock nut.
4. Check that the gap between the adjuster and spring retainer is between 1 and 1.5 mm.
5. Refit the side panel and secure the fasteners.

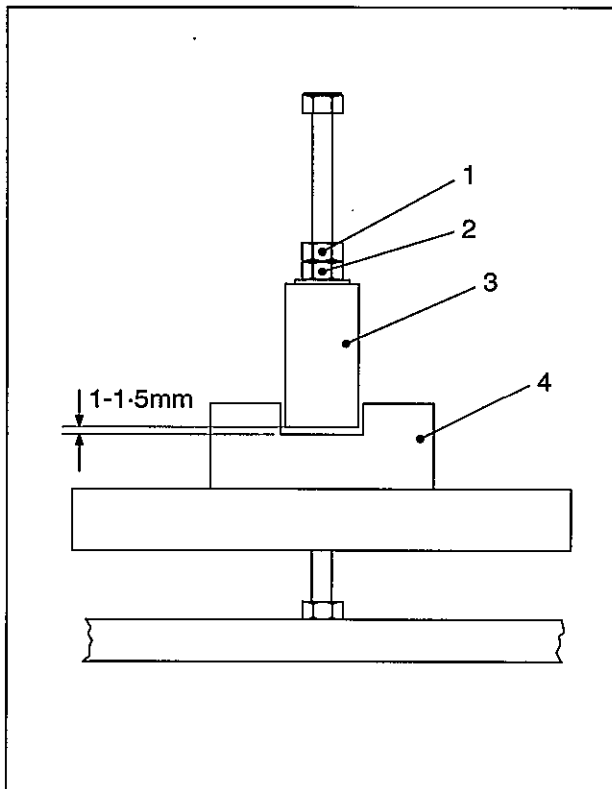
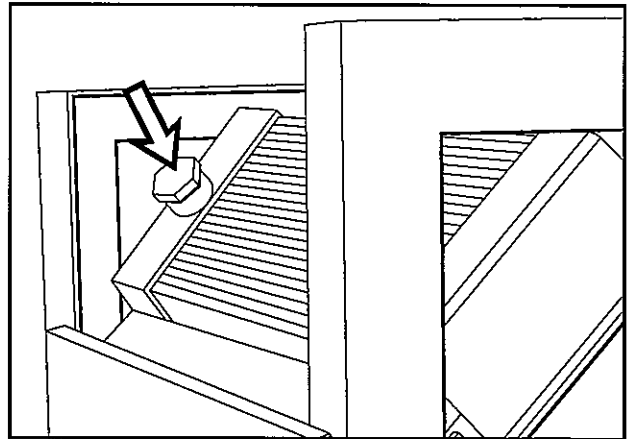


FIG 8.4 DRIVE BELT ADJUSTMENT

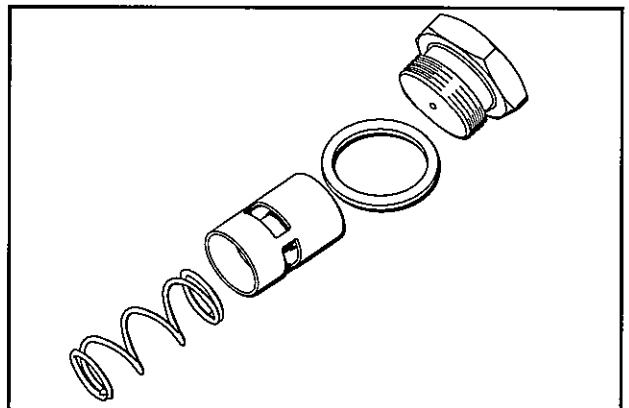
## 9. THERMOSTATIC BYPASS VALVE

### 9.1 Remove Thermostatic Bypass Valve

1. Remove the cooler discharge panel from the compressor unit to gain access to the thermostatic bypass valve.
2. Unscrew valve plug from pocket in cooler header.



3. Remove the valve complete with return spring.



**Note:** The thermostatic valve is supplied as a complete unit and must be changed if defective.



4. Check the thermostat element by immersing it in a water bath at approximately 6°C above the nominal setting. Bypass port 'B' should close. The nominal setting of the valve will be found stamped on the end of the element.

### 9.2 Install Thermostatic Bypass Valve

Installation is a reversal of the removal procedure. Install a new sealing washer when fitting the plug.

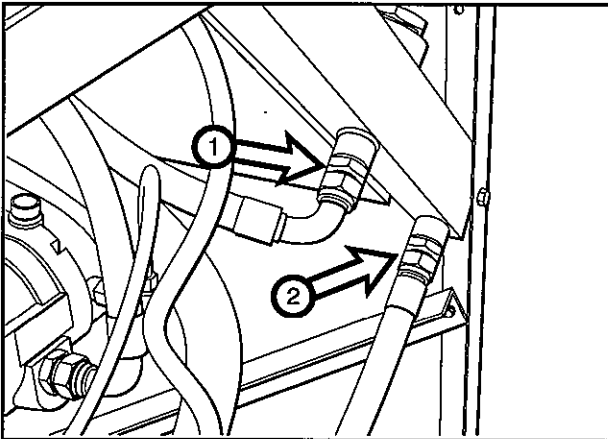
## 10. OIL COOLER

### 10.1 Remove Oil Cooler

	<b>WARNING</b>	
<ul style="list-style-type: none"><li>● Ensure electrical power is isolated in accordance with 'Dismantling Precautions' in Chapter 1.</li></ul>		

1. Remove the cooler discharge panel, roof panel, and motor side panel from the compressor unit.
2. Drain the oil from the compressor unit. Refer to 4.8.4 'To Drain the Oil' in chapter 6.
3. Disconnect oil inlet pipe (1) and oil outlet pipe (2).

**Note:** Oil may still be present in the oil cooler.



4. *Compressor models Cyclon 105, 107, 215 and 218:*  
Remove four screws securing the oil cooler support plate to the frame.

*Compressor models Cyclon 111 & 222:*  
Remove four screws securing the cooler directly to the frame.

5. Use two people to lift the cooler or cooler/support assembly out of the unit.

**Note:** Approximate weight of cooler

Cyclon 105 & 107	= 9 kg
Cyclon 111	= 13 kg
Cyclon 215 & 218	= 17 kg
Cyclon 222	= 26 kg

### 10.2 Clean Oil Cooler

The cooler should be removed and cleaned as normal practice during Routine Maintenance.



Cleaning of the oil cooler should be carried out by flushing through with a suitable degreaser, detergent or vapour solvent.

### 10.3 Install Oil Cooler

Installation is a reversal of the removal procedure.

## 11. AIR COOLER

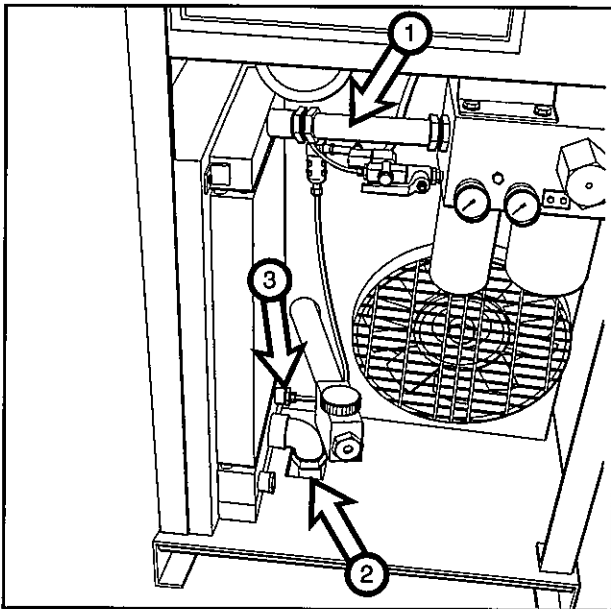
### 11.1 Remove Air Cooler

	<b>WARNING</b>	
<ul style="list-style-type: none"> <li>● Ensure electrical power is isolated in accordance with 'Dismantling Precautions' in Chapter 1.</li> </ul>		

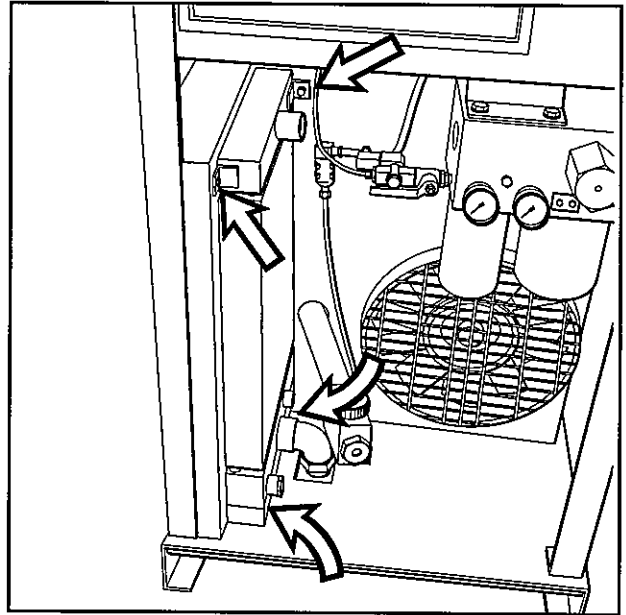
1. Remove the service panel from the front of the compressor unit.

**Note:** It may be necessary to remove the air intake filter (depending on compressor model) to prevent it from being damaged when the air cooler is removed.

2. Remove air delivery pipe (1) from cooler.
3. Disconnect cooler from user's pipework (2).
4. Disconnect regulation air pipe (3) from cooler to pressure switch.



5. Remove four screws securing cooler to frame.



6. Lift the cooler out of the unit.

**Note:** Approximate weight of cooler  
 Cyclon 105 & 107 = 4 kg  
 Cyclon 111 = 5 kg  
 Cyclon 215 & 218 = 11 kg  
 Cyclon 222 = 12 kg

### 11.2 Clean Air Cooler

The cooler should be removed and cleaned as normal practice during Routine Maintenance.

Accumulated dirt in the fins of the air cooler can normally be removed using compressed air or a steam cleaner. Cleaning should be carried out from the reverse side to the air flow.

### 11.3 Install Air Cooler

Installation is a reverse of the removal procedure.

AC20160-1538 (Issue 1)

# Repair Manual

 **105 – 222**

**air compressors**

Serial numbers from:

Cyclon 105 F160-0101

Cyclon 107 F161/0201

Cyclon 111 F162/0301

Cyclon 215 F163/0401

Cyclon 218 F164/0501

Cyclon 222 F165/0601

AC20160-1538 (Issue 1)

# Repair Manual

 **105 – 222**  
**air compressors**

Serial numbers from:

Cyclon 105 F160-0101

Cyclon 107 F161/0201

Cyclon 111 F162/0301

Cyclon 215 F163/0401

Cyclon 218 F164/0501

Cyclon 222 F165/0601



**Cyclon 105 – 222**  
**air compressors**



**AC20160-1538**  
**Repair Manual**

