

Quincy QSB/T™ Series Electronic Control

Instruction Manual

This manual contains important safety information and should be made available to all personnel who operate and/or maintain this product. Carefully read this manual before attempting to operate or perform maintenance on this compressor.



Manual No. 65002-QA

February 1998 Edition

QSB/T™ Control Operations

This manual describes the microprocessor control for the QSB/T series of Air Compressors.

The decal at the right shows the control layout for the electronic control panel.

The primary controls are on the right hand side of the panel, with the selected item being displayed on the LED digits in the top window.

The LED lamps in a vertical column, show the selected display parameter and/or any alarm conditions.

On applying system power the LED status lights will blink and the numeric display will show the version number of the software code installed. The system will be ready to run with the 'POWER' lamp on showing that the control board has power) and the 'SYSTEM PRESSURE' LED will be lit showing the pressure on the numeric display.

NOTE: A flashing '----' on the digit display, accompanied with an LED on the left, signifies a faulty sensor, either the pressure transducer or the temperature probe.

A **FAST** blinking LED indicates that the labeled function has been tripped; an over-pressure condition or motor overload or High Air Temperature (HAT) trip.

A **SLOW** blinking LED indicates that the Separator Differential Pressure (D.P.) switch has been tripped. A **STEADY** LED, along with a message blinking on the display, indicates a service time-out. The controller is programmed with recommended service intervals on the fluid filter and the air filter. These filters should be checked and serviced when convenient.

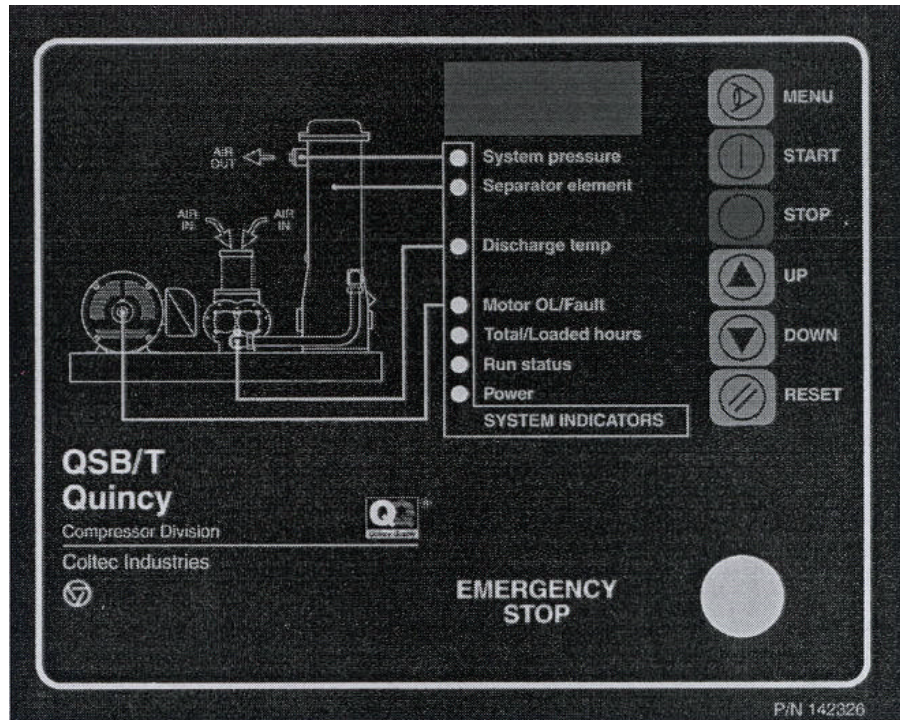

BASIC CONTROLS:

- 1) **MENU** - This button scrolls through the set parameters as indicated by the LED lamps to the left, in the following order:

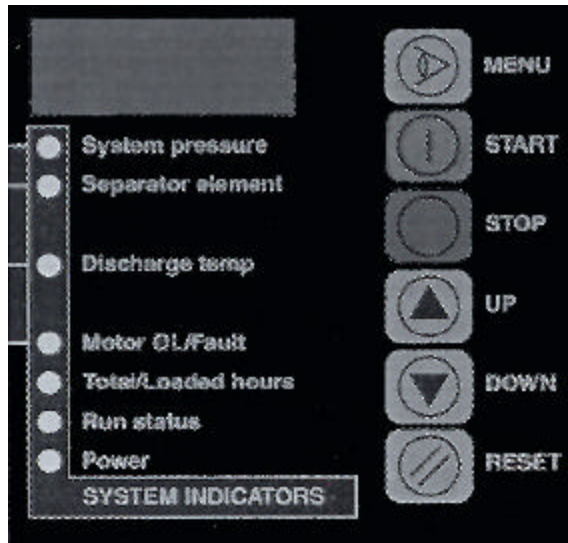

- a) System Pressure (default)
- b) Discharge Temperature
- c) Running (Total) Hours; Shows 'run' followed by the hours in alternating form.
- d) Loaded Hours; Shows 'load' followed by the hours in alternating form.
- e) Separator Hours: 'SEPA', followed by the hours in alternating form.
- f) Air Filter Hours* shows 'AIr.f' followed by the hours in alternating form.
- g) Fluid Filter Hours* shows 'Flu.f' followed by the hours in alternating form.
- h) Fluid Service/Sample Hours; 'FLu' followed by the hours in alternating form. (Total/Loaded LED)

- 2) **START** will start the compressor, if no major faults are present (open pressure sensor, temperature sensor, high temperature condition, or overload).

NOTE: The **RUN STATUS** LED will be **ON** to show that a start cycle is in progress. The compressor will not start if the line pressure is above the load point; the compressor will start when the line pressure drops below the load point. If the compressor is waiting to start, the 'Run Status' LED will flash rapidly. (*These have no associated LED indicators)

- 3) **STOP** will initiate a controlled stop on the compressor. The stop cycle will take about 5 seconds to complete. This is due to the system unloading and blowing down prior to stopping the motor.
- 4) **UP** and **DOWN** are used to select parameters in the setup menus.
- 5) **RESET** is used to clear a fault or service condition from the display panel.

NOTE: After a few minutes of inactivity, the control will return to the default display.

SYSTEM INDICATORS:

RUN STATUS indicates that the compressor is in a run state. A steady light indicates that the compressor is running. If this light is *flashing*, and the compressor is in a stopped condition, the compressor will *re-start at any time*. This also indicates that the compressor is about to start, when the auto-restart option is enabled.

LOAD/UNLOAD: The left-most digit on the numeric display will show 'L' when the compressor is loaded, and 'U' when unloaded.

PROGRAM SETUP MENUS

The program setup menus are accessed by holding both the UP and DOWN keys in, until the LED lamps on the left start to flash. Release the UP and DOWN keys, and when the numeric display shows -00- flashing, use the up key to select the desired menu (1, 2, and 3 are user menus).

There is a time limit to select the menu number. If this time period is exceeded, the control will return to the standard display mode.

NOTE: *The nomenclature on the decal beside the LED's does NOT represent the function of the LED in these menus.*

MENU 01: BASIC OPERATING ADJUSTMENTS.

LED 1: Use the MENU key to select the UNLOAD pressure, as indicated by a 'U' at the left-most digit. Use the UP or DOWN keys to adjust. **NOTE: Value is saved when display is no longer blinking.**

Use the MENU key to then select the LOAD pressure, as indicated by an 'L' at the left-most digit, Use the UP or DOWN keys to adjust.

LED 2: This allows the adjustment of the Wye/Delta (Y/D) time on the contactor: this is set to optimum at the factory. This should be set to allow the motor to reach full speed before the contactors switch from wye to delta connection.

LED 3: This is the AUTO-DUAL timer setting. This is how long the compressor will run in an unloaded state before shutting down (Minutes). When the delivery pressure falls below the LOAD setting after shutting down, the compressor will start up automatically. A 'd' will show in the left-most digit of the display to indicate this is the Auto-Dual timer.

LED 4: This is the AUTO-RESTART delay in Seconds. The compressor will delay this length of time on power-up, before automatically starting. An 'r' will show at the left-most digit. Set to 0 if auto restart is NOT required. **NOTE: AUTO-RESTART refers to the automatic starting of the compressor on power application.**

MENU 02: FILTER SERVICE HOURS

LED 1: This is the separator service hours setup. The display will show the hours remaining, alternating with 'SEPA'. On servicing the separator, this counter is set to the desired service interval.

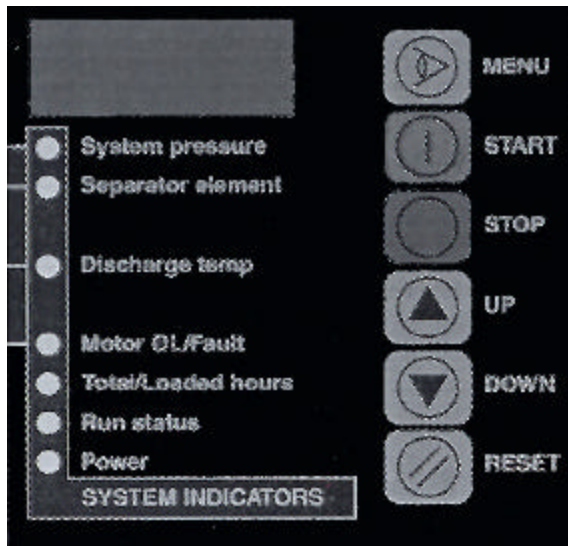

LED 2: This is the air filter service hours setup. The display will show the hours remaining, alternating with 'AIr.F'. On servicing the air filter, this counter is set to the desired service interval. An 'A' will blink at the left side of the display on time-out.

LED 3: This is the fluid filter service hours setup. The display will show the hours remaining, alternating with 'FLu.F'. Use the UP or DOWN keys to adjust this value to the desired range. An 'F' will blink at the left side of the display on time-out.

LED 4: This is the fluid sample/service hours setup. The display will show the hours remaining, alternating with 'FLu'. On servicing the fluid filter or taking a sample, this counter should be re-set to the desired service interval.

The LED's described above, will blink when the service intervals reach '00' in the main running display. As before, the setting is 'saved' when the display reading is steady.

MENU 03: DISPLAY UNITS AND MODEL TYPE

LED 1: Selects the Pressure display in PSIG or BAR. Use the Up or Down keys to select.

LED 2: Selects the Temperature Display in 'F or 'C. Use the Up or Down keys to select.

LED 3: Selects Compressor Model: QSF or QSB/QMB. (Set at the Factory)

LED 4: Set the Running (Total) Hours. Use the Up or Down keys to select. (This should never be adjusted except during controller replacement, to match recorded time from the previous one.)

LED 5: Sets the I.D. of the compressor. This may be used in a future network control option.

As before, the setting is 'saved' when the display reading is steady.

FAULTS:

- 1) **EMERGENCY STOP:** Pressing this button will cause the immediate halting of compressor operation. This is a redundant control. The microcontroller is signaled to halt operations and power is removed from all control relays; causing all circuits to open up. The LED indicators at the side of the panel will flash and 'STOP' will flash on the numeric display.

To reset the control, twist the stop button to release from the latched condition and press the RESET control button.

- 2) **CONTACTOR FAULT:** The side LED's will flash if the main contactor fails to close properly or fails to open in a controlled shutdown.
- 3) **OVERLOAD:** This LED will light, if the motor overload has tripped.

LED & MESSAGE INDICATORS:

- 1) Excessive pressure Error: Top LED flashes fast.
- 2) Separator Element clogged: Second LED flashes slowly.
- 3) Air Filter timer expired: The message 'AIRF' flashes on the display.
- 4) Excessive Temperature: Third LED flashes slowly.
- 5) Temperature error (broken wire etc.): Third LED flashes fast.
- 6) Fluid timer expired: The message 'FLUI' flashes on the display.
- 7) Motor Overload: Forth LED flashes fast.
- 8) Power line glitches (loss of cycles for longer than 40 milliseconds): The left 3 bars in the display flash indicating possible problems in the 3-phase power supply.

SERVICE REPLACEMENTS:

Prior to attempting any repairs of the electronic control or related components, disconnect and lock out all power supplies to the compressor plus any remote controllers. Assure yourself that power is removed from the compressor by checking for any AC voltage at the line side of the motor starter.

Replacing sensors or transducers:

To replace a temperature sensor (HAT probe), disconnect conduit from elbow of probe. Cut wires and remove probe from the side of the reservoir. Install new probe into discharge tube. Connect wires of new probe to existing wires using suitable splice and insert in to conduit. Connect conduit to elbow of probe. Complete HAT tests and assure system functions correctly.

To replace a pressure transducer, open enclosure door. The pressure transducer is located in the upper left-hand corner of the panel. Remove wire channel cover. Trace wires from transducer to the microprocessor. **NOTE:** Prior to touching any portion of the printed circuit board, you will need to ground yourself to remove any static electricity using a grounding wrist strap. After assuring the compressor is properly grounded, you may clip the grounding wrist strap to any exposed metal on the frame of the compressor. Disconnect transducer wires at microprocessor. Remove transducer from Teflon bushing. Replacement of the Teflon bushing is recommended any time a transducer is replaced. Install new Teflon bushing and transducer. Connect transducer wires to microprocessor and reinstall wire channel cover.

Replacing electronic control:

NOTE: Prior to touching any portion of the printed circuit board, you will need to ground yourself to remove any static electricity using a grounding wrist strap. After assuring the compressor is properly grounded, you may clip the grounding wrist strap to any exposed metal on the frame of the compressor.

Prior to replacing electronic control, it will be necessary to gather and retain information regarding total running hours, separator hours, air filter hours, fluid filter hours and fluid service/sample hours. This data will be transferred to the replacement control prior to start-up.

To replace the electronic control, remove screws attaching control to door of enclosure. Remove and discard wire tie-wraps. **NOTE:** Prior to removing any wiring from the electronic control, identify individual wire location. Refer to electrical wiring diagram. Install new electronic control panel and install wiring in accordance with electrical wiring diagram. Attach to door of enclosure using existing hardware. Install new wire tie-wraps to secure wiring to wire bundle.

Operational test:

Remove tag and lock out tools. Restore power to unit. If electronic control was replaced, refer to the Program Setup Menu to program the replacement electronic control. Once completed, perform an operational test to assure unit is operating correctly.

WIRING DIAGRAM - ACROSS THE LINE STARTING

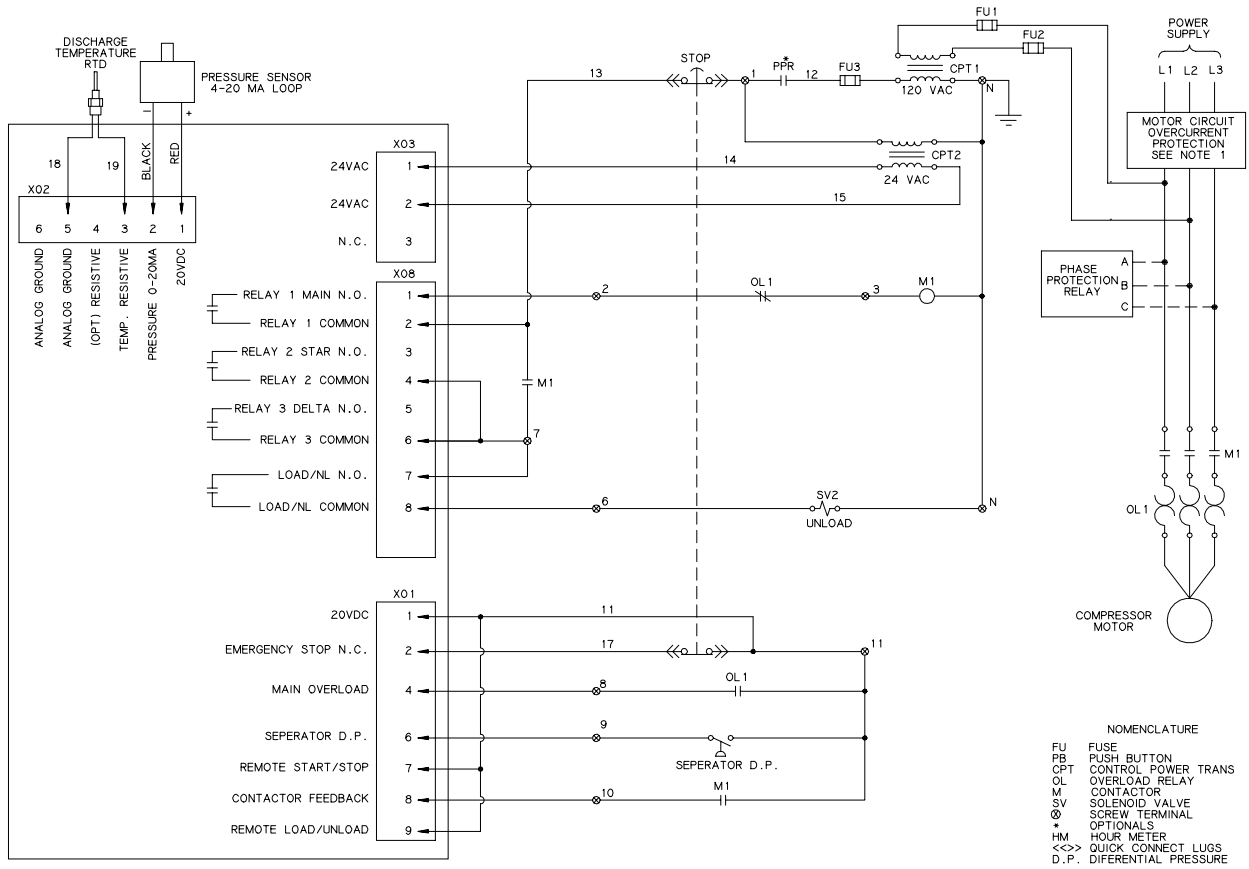

- NOTES**
- 1) AT INSTALLATION THE CUSTOMER IS TO PROVIDE DISCONNECT AND BRANCH CIRCUIT OVERCURRENT PROTECTION IN ACCORDANCE WITH THE NATIONAL ELECTRICAL CODE AND/OR ANY LOCAL CODES HAVING PRECEDENCE.
 - 2) UNLESS OTHERWISE SPECIFIED ALL WIRES ARE RED EXCEPT "N" WIRES ARE WHITE AND "G" WIRE IS GREEN.
 - 3) ALL PUSH BUTTONS, SELECTOR SWITCHES, HOURMETER, AND INDICATOR LIGHTS ARE LOCATED IN THE CONTROL PANEL.
 - 4) REMOVE ANY JUMPERS ON OVERLOADS THAT ARE FACTORY INSTALLED.

WIRING DIAGRAM - WYE-DELTA STARTING

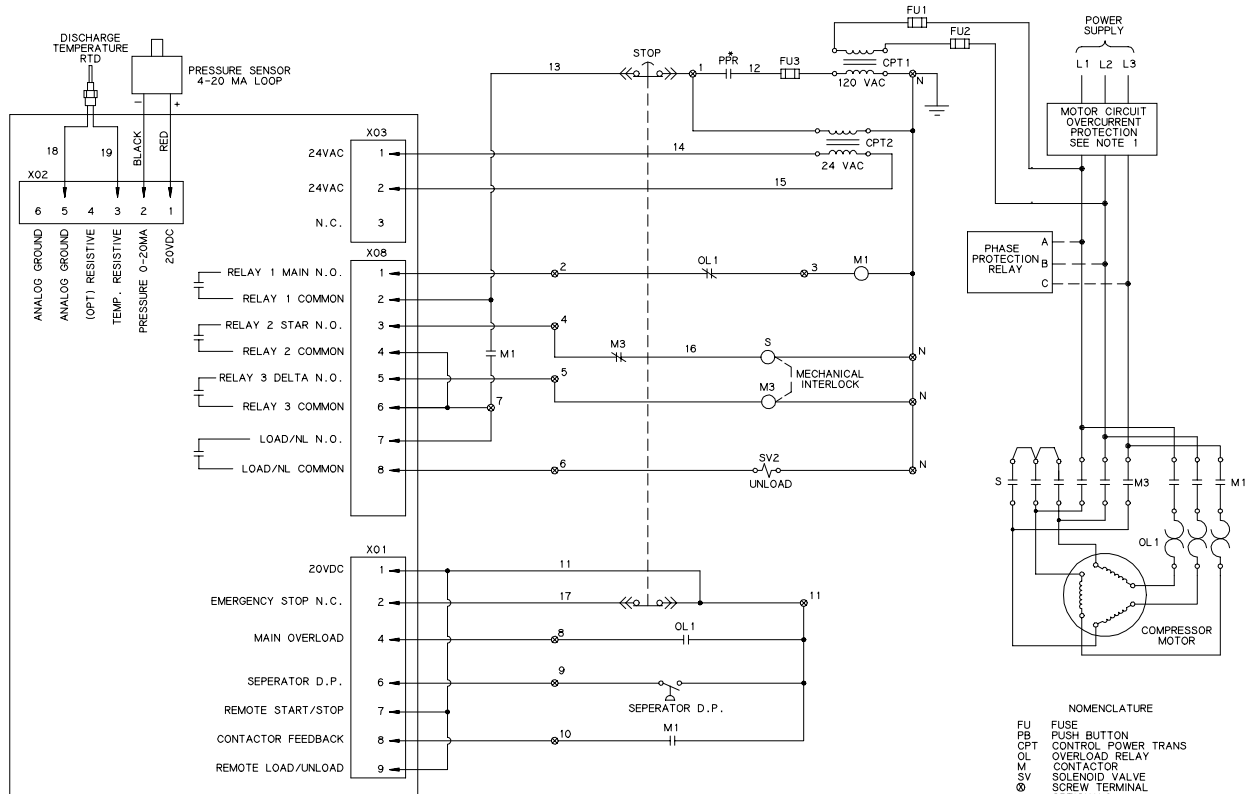

- NOTES**
- 1) AT INSTALLATION THE CUSTOMER IS TO PROVIDE DISCONNECT AND BRANCH CIRCUIT OVERCURRENT PROTECTION IN ACCORDANCE WITH THE NATIONAL ELECTRICAL CODE AND/OR ANY LOCAL CODES HAVING PRECEDENCE.
 - 2) UNLESS OTHERWISE SPECIFIED ALL WIRES ARE RED EXCEPT "N" WIRES ARE WHITE AND "G" WIRE IS GREEN.
 - 3) ALL PUSH BUTTONS, SELECTOR SWITCHES, HOURMETER, AND INDICATOR LIGHTS ARE LOCATED IN THE CONTROL PANEL.
 - 4) REMOVE ANY JUMPERS ON OVERLOADS THAT ARE FACTORY INSTALLED.

- NOMENCLATURE**
- FU FUSE
 - PB PUSH BUTTON
 - CPT CONTROL POWER TRANS
 - OL OVERLOAD RELAY
 - M CONTACTOR
 - SV SOLENOID VALVE
 - ∅ SCREW TERMINAL
 - * OPTIONALS
 - HM HOUR METER
 - <<>> QUICK CONNECT LUGS
 - D.P. DIFFERENTIAL PRESSURE

Quincy Service is always near. There are authorized Quincy Distributors located throughout the United States & Canada that stock genuine Quincy parts & accessories for a wide range of Quincy products.

Quincy Service specialists are factory trained and will help keep you in business. Call for Authorized Quincy Service.

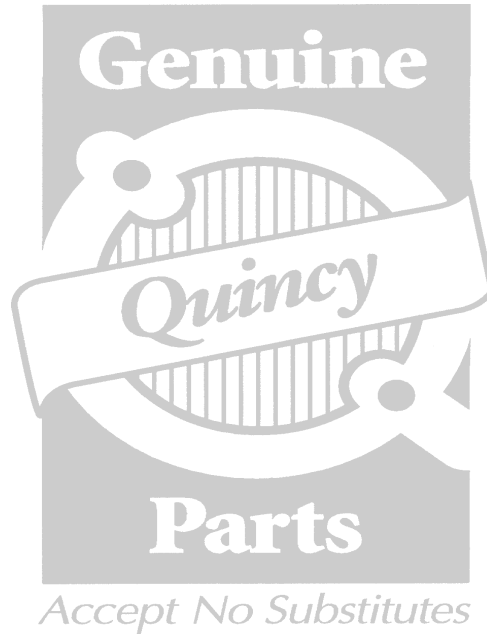

Quincy Compressor[®]

True Blue Reliability[™]

Reciprocating / Systems: 217.222.7700
Rotary / Vacuum / Systems: 334.937.5900
Nearest Distributor: 888.424.7729
E-mail: trueblue@quincycompressor.com
Discover: www.quincycompressor.com



BFGoodrich

© 2000 Quincy Compressor a BFGoodrich Company Business
All Rights Reserved. Litho in U.S.A.