



an EnPro Industries company

Control Panels

Non Combination Single Power Source Start / Stop Duplex Alternating

Instruction Manual

This manual contains important safety information and must be carefully read in its entirety and understood prior to installation by all personnel who install, operate and/or maintain this product.

Manual No. 50353-100

December 2004 Edition

Contents

SECTION 1	SAFETY
Safety First	2
SECTION 2	SYSTEM DYNAMICS
Description & Application	5
Auto Restart After Power Failure	5
Mode of Operation	5
Starting Sequences	5
Alarm Fault Shutdown Conditions	6
System Components	6
Electrical Supply Requirements	7
Electrical Specifications	8
SECTION 3	START-UP
Starting the Compressor	9
SECTION 4	OPERATION
Resetting Controls (After an Alarm Fault Shutdown Condition)	10
SECTION 5	MAINTENANCE
Stopping for Maintenance	11
Pressure Switch Adjustment	11
SECTION 6	TROUBLESHOOTING
Troubleshooting Chart	13
SECTION 7	REFERENCE INFORMATION
Component Drawings	14
Wiring Diagram	16

WARRANTY

Quincy Compressor Control Panels and related parts are warrantied for a period of one year in service, provided the panels and related parts are sold with or used in conjunction with existing Quincy Compressor compressor models. A 90 day in-service warranty applies to all other situations.

SAFETY

Safety First

At Quincy Compressor safety is not only a primary concern, but a faithfully performed practice. Beginning with the design stage, safety is built into “The World’s Finest Compressor”. It is the intention of this manual to pass along the “safety first” concept to you by providing safety precautions throughout its pages.

“**DANGER !**”, “**WARNING !**”, and “**CAUTION !**” are displayed in large bold capital letters in the left hand column to call attention to areas of vital concern. They represent different degrees of hazard seriousness, as stated below. The safety precaution is spelled out in bold upper and lower case letters in the right hand column.

DANGER !

Immediate hazards which will result in severe personal injury or death.

WARNING !

Hazards or unsafe practices that could result in personal injury or death.

CAUTION !

Hazards or unsafe practices which could result in minor personal injury, product or property damage.

Each section of this instruction manual, as well as any instructions supplied with the compressor and by manufacturers of supporting equipment, should be read and understood prior to starting the compressor. If there are any questions regarding any part of the instructions, please call your local Quincy distributor, or the Quincy Compressor factory before creating a potentially hazardous situation. Life, limb, or equipment could be saved with a simple phone call.

Compressors are precision high speed mechanical equipment requiring caution in operation to minimize hazard to property and personnel. There are many obvious safety rules that must be observed in the operation of this type of equipment. Listed below are some additional safety precautions that must be observed.

- Transfer of toxic, dangerous, flammable or explosive substances using Quincy Compressor products is at the user’s risk.
- Turn off and lockout/tagout (per OSHA regulation 1910.147) the main power disconnect switch before attempting to perform maintenance on any part of the unit.
- Do not attempt to service any part of the unit while it is operating.
- Per OSHA regulation 1910.147, relieve the system of all pressure before attempting to service any part of the unit.

- Allow ample time for the compressor to cool before performing service procedures. Some surface temperatures exceed 350°F when the compressor is operating.
- Do not operate the unit with any of its safety guards, shields, or screens removed.
- Do not remove or paint over any DANGER!, WARNING!, CAUTION!, or instructional materials attached to the compressor. Lack of information regarding hazardous conditions can cause property damage or personal injury.
- Periodically check all pressure relief valves for proper operation.
- Do not change the pressure setting of the pressure relief valve, restrict the function of the pressure relief valve, or replace the pressure relief valve with a plug.
- Do not install a shutoff valve in the compressor discharge line without first installing a pressure relief valve of proper size and design between the shutoff valve and the compressor.
- Do not use plastic pipe, rubber hose, or lead-tin soldered joints in any part of the compressed air system.
- Alterations must not be made to this compressor without Quincy Compressor's approval.
- Be sure that all tools, shipping and installation debris have been removed from the compressor and installation site prior to starting the compressor.
- Do not operate the compressor in excess of the ASME pressure vessel rating for the receiver or the service rating of the compressor, whichever is lower.
- Make a general overall inspection of the unit daily and correct any unsafe situations. All fasteners and fittings must be kept tight.
- Reckless behavior of any kind involving compressed air is dangerous and can cause very serious injury to the participants.
- Provisions should be made to have the instruction manual readily available to the operator and maintenance personnel. If for any reason any part of the manual becomes illegible or the manual is lost, have it replaced immediately. The instruction manual should be read periodically to refresh one's memory. It may prevent a serious or fatal accident.
- Never use a flammable or toxic solvent for cleaning the air filter or any parts.

DANGER !

Air used for breathing or food processing must meet OSHA 29 CFR 1910.134 or FDA 21 CFR 178.3570 or NFPA 99 regulations. Failure to do so may cause severe injury or death.

The owner, lessor or operator of any compressor unit manufactured by Quincy Compressor is hereby warned that failure to observe the safety precautions and procedures outlined in this manual may result in serious personal injury, damage to property, and may void your warranty. Quincy Compressor must authorize all warranty service. Before contacting your distributor or the factory, check the maintenance requirements and the troubleshooting guide for your compressor. Most warranty issues can be resolved by following proper maintenance procedures.

Quincy Compressor neither states as fact, nor in any way implies that the above list of safety precautions is an all inclusive list, the observance of which will prevent all damage to property or injury to personnel.

Every effort has been taken to ensure that complete and correct instructions have been included in this manual. However, possible product updates and changes may have occurred since this printing. Quincy Compressor reserves the right to change specifications without incurring any obligation for equipment previously or subsequently sold.

Description & Application

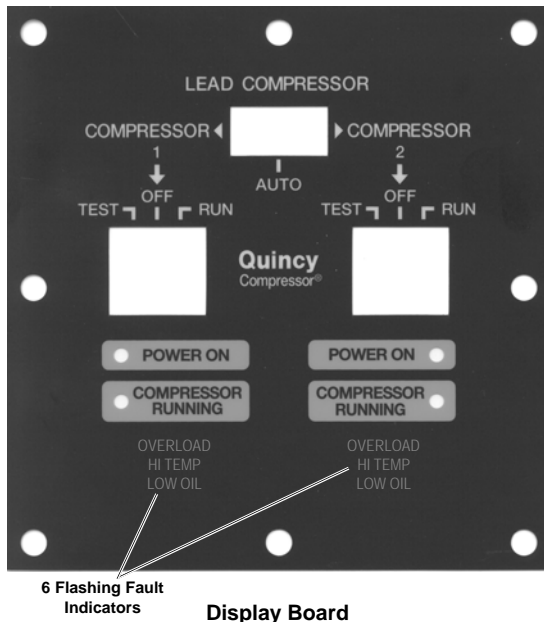

The Quincy Compressor single power source control panel is designed to control the operation of two separate air compressors feeding into one tank. This control panel provides the ability to define a starting sequence in which the compressors operate, and/or manually disable one or both compressors. It will detect potential equipment damaging conditions such as high temperature, low oil pressure or level, and motor overloads.

A display board is mounted on the front of the single power source control panel and is equipped with 2 “POWER ON” LED’s, 2 “COMPRESSOR RUNNING” LED’s, 2 TEST-OFF-RUN” selector switches, 1 “LEAD COMPRESSOR” selector switch and 6 flashing fault indicators.

Auto Restart After Power Failure

The Quincy Compressor single power source control panel is only available in a non-combination configuration. If there is a power outage or sag, the compressors will restart automatically and resume service without the need for the compressors to be manually reset.

Mode of Operation (Start / Stop)

“START / STOP” mode of operation will start a compressor when its pressure switch (set to a predetermined level) detects a demand for compressed air (air pressure in the air tank falls to the predetermined level). The compressor will run until the demand for compressed air is satisfied (the contacts of the pressure switch open and the compressor stops when the air pressure in the tank rises to a predetermined level).

Starting Sequences

Lead

A compressor designated as the “LEAD” compressor is controlled by the lead pressure switch and always starts first when there is a demand for compressed air. The other compressor in the system is controlled sequentially by the lag pressure switch. The compressor that starts last in a system is the lag compressor.

Auto

When the compressors are set to operate in the “AUTO” starting sequence, the controls alternate, turning on a different compressor each time the lead pressure switch detects a demand for compressed air. For instance, a compressor that’s running turns off when the demand is met (pressure switch contacts open). The next time there is a demand for compressed air, the lead pressure switch detects the demand, pressure switch contacts close, and an alternate compressor in the system starts and runs until the demand is met. The controls continue to select an alternate compressor to operate when the next demand for compressed air occurs.

Alarm Fault Shutdown Conditions

Each compressor in the system can be equipped with sensors that detect the following alarm fault shutdown conditions: motor overloads, high air temperature, and low oil level or pressure. In the event of an alarm fault shutdown condition, the affected compressor is shutdown, the “OVERLOAD”, “HITEMP” or “LOW OIL” fault indicator on the display board flashes (indicating the type of condition), the system alarm SPDT dry contacts on the logic board actuate and the compressor next in line starts.

The controls of a compressor that has been shutdown because of an alarm fault shutdown condition will not detect subsequent conditions and must be reset before the compressor can be restarted (see **SECTION 4, *Resetting Controls***).

System Components

Display Board

The display board allows the operator to set the compressor to desired settings and indicates the operating conditions. It consists of a printed circuit board located on the control panel door.

Logic Board

Connects sensor inputs and alarm outputs. Consists of a printed circuit board located inside the control panel.

Elapsed Time Meter (Standard on All Panels)

The elapsed time meter records the operating hours for each compressor and is mounted on the control panel door.

High Air Temperature Probe (Standard on QRD Series)

Temperature sensor located in each cylinder head of the compressor (QRD Series), or in the discharge line of the compressor.

Low Oil Level Switch (Optional Equipment)

Detects low oil level conditions in the crankcase of an oil lubricated compressor. The switch is wired to the logic board.

Low Oil Pressure Switch (Optional Equipment)

Detects low oil pressure condition in a pressure lubricated system. The switch is located inside the control panel and wired to the logic board of each compressor. A tube is connected between the low oil pressure switch and an oil pressure port on each compressor. The control panel must be mounted no more than 15 feet from the compressor and 3/8” copper tube must be used with no 90° bends or vertical runs.

Motor Starter

A device equipped with electrical contacts, located inside the control panel. When power is applied to the motor starter, its electrical contacts close and the compressor’s motor starts.

Overload Relay

Monitors the compressor motor electrical current and turns the compressor motor off when an overload is sensed. It is mounted on the bottom of the motor starter. The overload relay is designed for motors with a 1.15 service factor. The overload relay setting should be adjusted to the motor nameplate amp rating. If the motor has a service factor rating other than 1.15, the overload relay setting must be adjusted to compensate. Contact your Quincy distributor for assistance.

Pressure Switch

Lead (Pressure Switch 1) starts the lead compressor.

Lag (Pressure Switch 2) starts the second compressor.

Electrical Supply Requirements

The electrical installation of this unit must be performed by a qualified electrician with knowledge of the National Electrical Code (NEC), OSHA code and/or any local or state codes having precedence. **Note: This unit must be grounded.**

WARNING !

Each compressor must be labeled to indicate which disconnect switch it is controlled by.

Before installation, the electrical supply must be checked for adequate wire size and transformer capacity. A suitable circuit breaker or fused disconnect switch must be provided. When a 3 phase motor is used to drive a compressor, any unreasonable voltage imbalance between the legs must be eliminated and any low voltage corrected to prevent excessive current draw. **NOTE: If voltage drops below 207 volts, use a 200 volt motor. Do not substitute with a triple voltage (208/230-460) 3 phase motor.**

CAUTION !

Verify all wires are secure and fasteners are torqued before connecting power to the unit.

The installation, electric motor, wiring, and all electrical controls must be in accordance with NFPA 70 National Electric Code, National Electric Safety Code, state and local codes. Failure to abide by the national, state and local codes may result in physical harm and/or property damage.

DANGER !

High voltage may cause personal injury or death. Disconnect and lockout/tagout per OSHA regulation 1910.147 all electrical power supplies before opening the electrical enclosure or servicing.

WARNING !

Never assume a compressor is safe to work on just because it is not operating. It could restart at any time. Follow all safety precautions outlined in SECTION 5, *Stopping For Maintenance*.

CAUTION !

NEMA electrical enclosures and components must be appropriate to the area installed.

CAUTION !

Overload relays are designed to protect the motor from damage due to motor overload. If the overload relay trips persistently, DO NOT CONTINUE TO PUSH THE RESET BUTTON! Contact your local Quincy distributor for assistance.

Electrical Specifications

Enclosure Type

NEMA-1 or NEMA-4

Models by Horsepower

1, 1.5, 2, 3, 5, 7.5, 10, 15, 20, 25 and 30

Input Voltage

100 VA Control Power Transformers @ 208, 230, 460, 575 VAC 50/60 HZ.
Fused primary and a 120 VAC fused secondary

Logic Board Inputs

2 Pressure Switch Input. Nominal 120 VAC. Closed contacts start compressor. Each successive compressor starts on a 2 second delay to prevent all compressors from starting simultaneously on power-up.

3 Alarm Input Switches (high air temperature, motor overload & low oil level or pressure). Nominal 120 VAC

The opening of the high air temperature probe contacts, or closing of the motor overload relay contacts will initiate an alarm after a preset delay of 3 seconds. Opening of the low oil level switch or pressure switch will initiate an alarm after a preset delay of 12 seconds. Closure of the high air temperature probe contacts, low oil level switch or opening of the motor overload relay contacts during this delay will reset the delay and will not create an alarm condition. The alarm inputs are not active when the compressor is not running.

Logic Board Outputs:

2 Motor Starter: 120 VAC @ 85 VA sealed (1185 VA inrush)

2 Elapsed Time Meter: 120 VAC at 8 VA whenever the corresponding starter is on. This device is activated whenever the motor starter is activated.

2 Alarm Output: single pole double throw dry contact. 10 amp. resistive at 120/240 VAC. Contacts actuate when any of these fault conditions occur: OVERLOAD, HI TEMP. or LOW OIL.

Motor Starter Auxiliary Contacts

1 normally open for each motor starter pre-wired to terminal strip
0° to 50°C (32° to 120°F)

Operating Temperature

0° to 50°C (32° to 120°F)

Storage Temperature

-40° to 70°C (-40° to 158°F)

Starting the Compressor

This instruction manual, as well as any instructions supplied with the compressor and by manufacturers of supporting equipment, should be read and understood prior to starting the compressor. If there are any questions regarding any part of the instructions, please call your local Quincy distributor, or the Quincy Compressor factory.

WARNING !

Never assume a compressor is safe to work on just because it is not operating. It could restart at any time. Follow all safety precautions outlined in SECTION 5, *Stopping For Maintenance*.

Refer to the compressor manual for pre-starting instructions.

- Step 1** Turn the remote disconnect switch to “ON” position (“POWER ON” LED will light).
- Step 2** Select the desired starting sequence by pressing the “LEAD COMPRESSOR” selector switch on the display board.
- Step 3** Jog the compressor by pressing the TEST / OFF / RUN switch to the “TEST” position to check the rotational direction of the compressor flywheel. It should agree with the rotation arrow on the compressor. **Each compressor must be checked for proper flywheel rotation!** (During the test the “COMPRESSOR RUNNING” LED will illuminate and the “OVERLOAD”, “HI TEMP” and “LOW OIL” fault indicators will flash intermittently. Release the TEST / OFF / RUN switch to stop the compressor.
- Step 4** Start the compressors by pressing the TEST / OFF / RUN switches to the “RUN” position. The compressors will start in sequence after a 2 second time delay.
- Step 5** Watch and listen for excessive vibration and strange noises. If either exist, stop the compressors. Refer to the compressor instruction manual for help in determining the cause of such problems.
- Step 6** Check the air receiver pressure gauge or system pressure gauges for proper readings. If inadequate or excessive air pressure conditions exist, refer to the compressor instruction manual.

When starting the compressor for the first time, observe compressor operation closely for the first hour of operation and then frequently for the next seven hours. After the first eight hours, monitor the compressor at least once every eight hours.

Resetting Controls (After an Alarm Fault Shutdown Condition)

- Step 1** Turn the TEST/OFF/RUN switches of both compressors to the “OFF” position.
- Step 2** Turn the remote disconnect switch to the “OFF” position.
- Step 3** Correct the fault condition (*refer to SECTION 6, Troubleshooting Chart*).
- Step 4** Turn the remote disconnect switch to the “ON” position.
- Step 5** Turn the TEST/OFF/RUN switches of both compressors to the “RUN” position to start the compressors.

Stopping for Maintenance

The following procedures should be followed when stopping the compressor for maintenance or service:

Step 1 Per OSHA regulation 1910.147: The Control of Hazardous Energy Source (Lockout/Tagout), disconnect and lockout the main power source. Display a sign in clear view at the main power switch stating that the compressor is being serviced.

WARNING !

Never assume a compressor is safe to work on just because it is not operating. It may be in the STANDBY mode and may restart any time.

Step 2 Isolate the compressor from the compressed air supply by closing a manual shutoff valve downstream from the compressor. Display a sign in clear view at the shutoff valve stating that the compressor is being serviced.

Step 3 Open a pressure relief valve within the pressurized system to allow the system to be completely depressurized. **NEVER** remove a plug to relieve the pressure!

Step 4 Open all manual drain valves within the area to be serviced.

Step 5 Wait for the unit to cool before starting to service. (Temperatures of 125°F can burn skin. Some surface temperatures exceed 350°F when the compressor is operating.)

Pressure Switch Adjustment

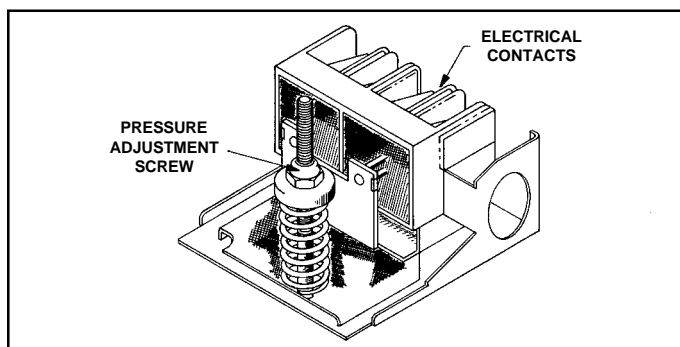

Pressure Switch

Pix 1067

Pressure switches provided by Quincy Compressor are preset at the factory and usually do not require adjustment.

The following procedures can be performed by a qualified electrician to adjust the pressure switch. While the compressor is running, screw the spring loaded adjustment screw in (clockwise) to increase the amount of air pressure required to open the switch and stop the unit. Screw the spring loaded adjustment screw out (counterclockwise) to decrease the amount of air pressure required to open the switch and stop the unit.

Pressure switch settings are staggered (i.e. Pressure Switch #1 set @ 80-100 PSIG, Pressure Switch #2 set @ 70-90 PSIG. If the switches are not staggered, the controls will not operate properly and system alarm conditions may occur.

WARNING !

Electric power always exists inside the pressure switch whenever the compressor package is connected to a power supply. Be careful not to touch any electrical contacts when setting the pressure switch.

WARNING !

Never exceed the design pressure for the system or overload the motor beyond its Maximum Amp Draw.

* Full Load Amps x Service Factor = Maximum Amp Draw

**Full Load Amps (FLA) & Service Factor can usually be found on the motor nameplate.*

Troubleshooting Chart

Refer to this chart when troubleshooting and diagnosing fault conditions.

FAULT CONDITION	REACTION	CORRECTIVE ACTION
HI TEMP	<ol style="list-style-type: none"> 1. Compressor shuts down. 2. Flashing fault indicator on display board. 3. SPDT dry contact actuates on logic board. 	<ol style="list-style-type: none"> 1. Turn TEST/OFF/RUN switches & disconnect switch to "OFF" position. 2. Check for loose wire on HAT probe or terminal block. Tighten. 3. Check for defective HAT probe. Replace. 4. Check for defective basic compressor. Repair or replace. 5. Turn disconnect switch & TEST/OFF/RUN switch to "ON" position to reset.
LOW OIL	<ol style="list-style-type: none"> 1. Compressor shuts down. 2. Flashing fault indicator on display board. 3. (SPDT dry contact) actuates on logic board. 	<ol style="list-style-type: none"> 1. Turn TEST/OFF/RUN switches & disconnect switch to "OFF" position. 2. Check for low oil level/pressure. Add oil or adjust pressure. 3. Check for loose wire on low oil level switch or terminal block. Tighten. 4. Check for plugged oil line to low oil switch. Clear the line. 5. Turn disconnect switch & TEST/OFF/RUN switch to "ON" position to reset.
OVERLOAD	<ol style="list-style-type: none"> 1. Compressor shuts down. 2. Flashing fault indicator on display board. 3. SPDT dry contact actuates on logic board. 	<ol style="list-style-type: none"> 1. Turn TEST/OFF/RUN switches & disconnect switch to "OFF" position. 2. Check overload relay for proper setting. 3. Check for loose wire on overload relay or motor terminals. Tighten. 4. Ambient temperature above 104°F. Reduce ambient temperature. 5. Motor drawing high amps. Check compressor speed & motor. 6. Motor lead wires too small. Replace with properly sized wires. 7. Reset the overload relay inside the control panel for affected compressor control. If condition persists, DO NOT CONTINUE TO PUSH THE RESET BUTTON! Contact your local Quincy distributor for assistance. 8. Turn disconnect switch & TEST/OFF/RUN switch to "ON" position to reset.

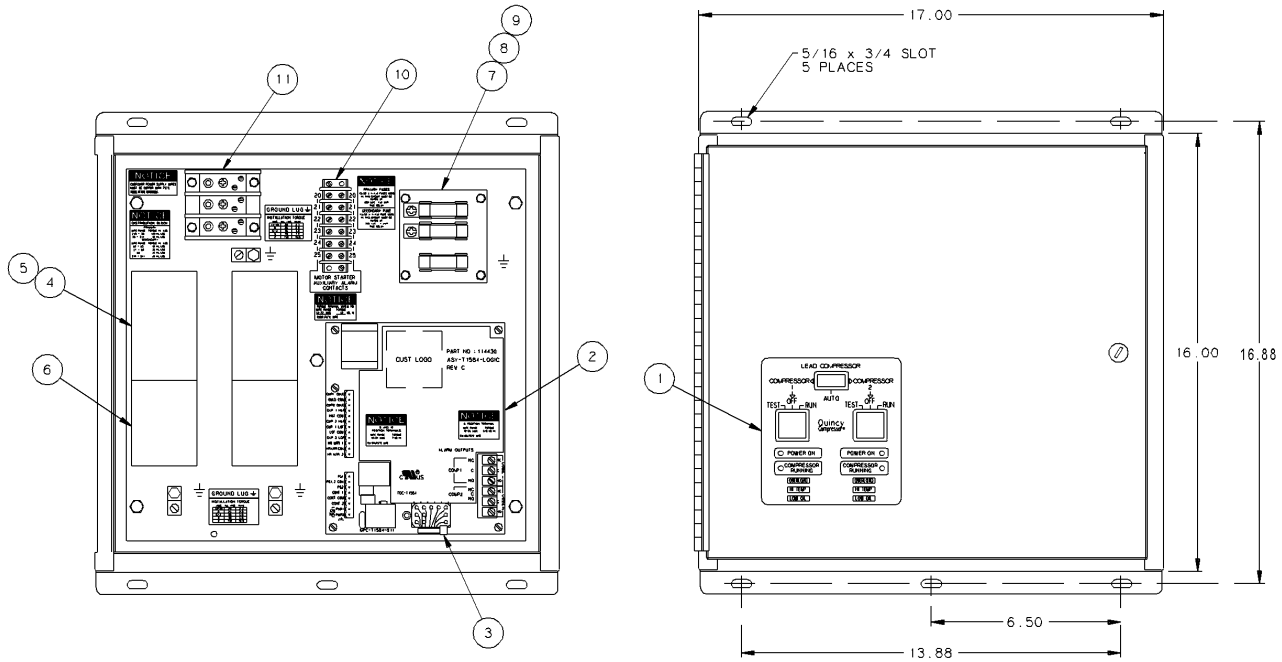

NEMA-1 Control Panel

#	Description	Qty.	Part Number
1	Display Board	1	114431
2	Logic Board	1	114430
3	Interface Harness	1	114432
4	Control Circuit Harness, 120V without CPT	1	114463
4	Control Circuit Harness, with CPT	1	114458
5	Motor Starter Contactor	2	
6	Motor Starter Overload Relay	2	
7	Control Power Transformer (100VA @ 208V, 230V or 460V)	1	115596-101
	Control Power Transformer (100VA @ 380V, or 575V)	1	115596-105
8	Fuse, Primary, 1 amp Time-Delay (200V/230V)	2	128857-011
8	Fuse, Primary, 1/2 amp Time-Delay (460V/575V)	2	128857-002
9	Fuse, Secondary, 1 amp Time-Delay (200V - 575V)	1	22453
10	Motor Starter Auxiliary Contact Field Connection	1	
11	Power Distribution Block	1	129229-003

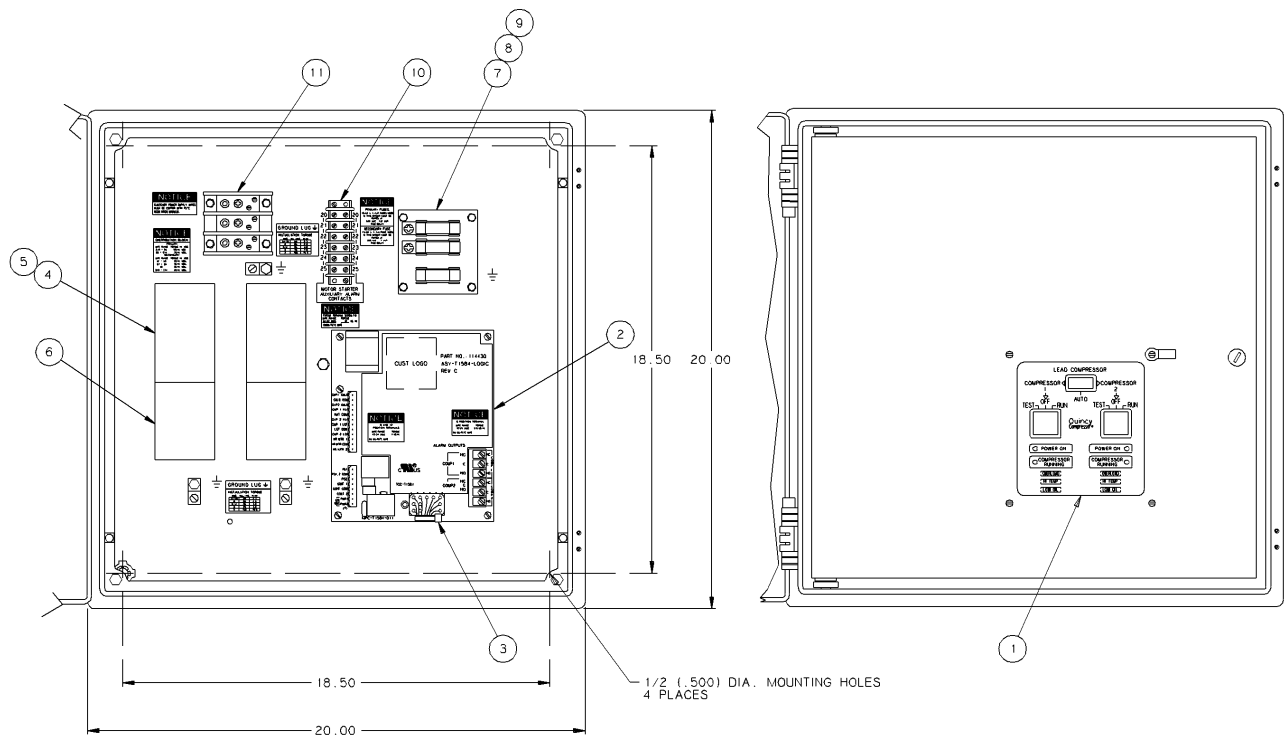

NEMA-4 Control Panel

#	Description	Qty.	Part Number
1	Display Board	1	114431
2	Logic Board	1	114430
3	Interface Harness	1	114432
4	Control Circuit Harness, 120V without CPT	1	114463
4	Control Circuit Harness, with CPT	1	114458
5	Motor Starter Contactor	2	
6	Motor Starter Overload Relay	2	
7	Control Power Transformer (100VA @ 208V, 230V or 460V)	1	115596-101
	Control Power Transformer (100VA @ 380V, or 575V)	1	115596-105
8	Fuse, Primary, 1 amp Time-Delay (200V/230V)	2	128857-011
8	Fuse, Primary, 1/2 amp Time-Delay (460V/575V)	2	128857-002
9	Fuse, Secondary, 1 amp Time-Delay (200V - 575V)	1	22453
10	Motor Starter Auxiliary Contact Field Connection	1	
11	Power Distribution Block	1	129229-003

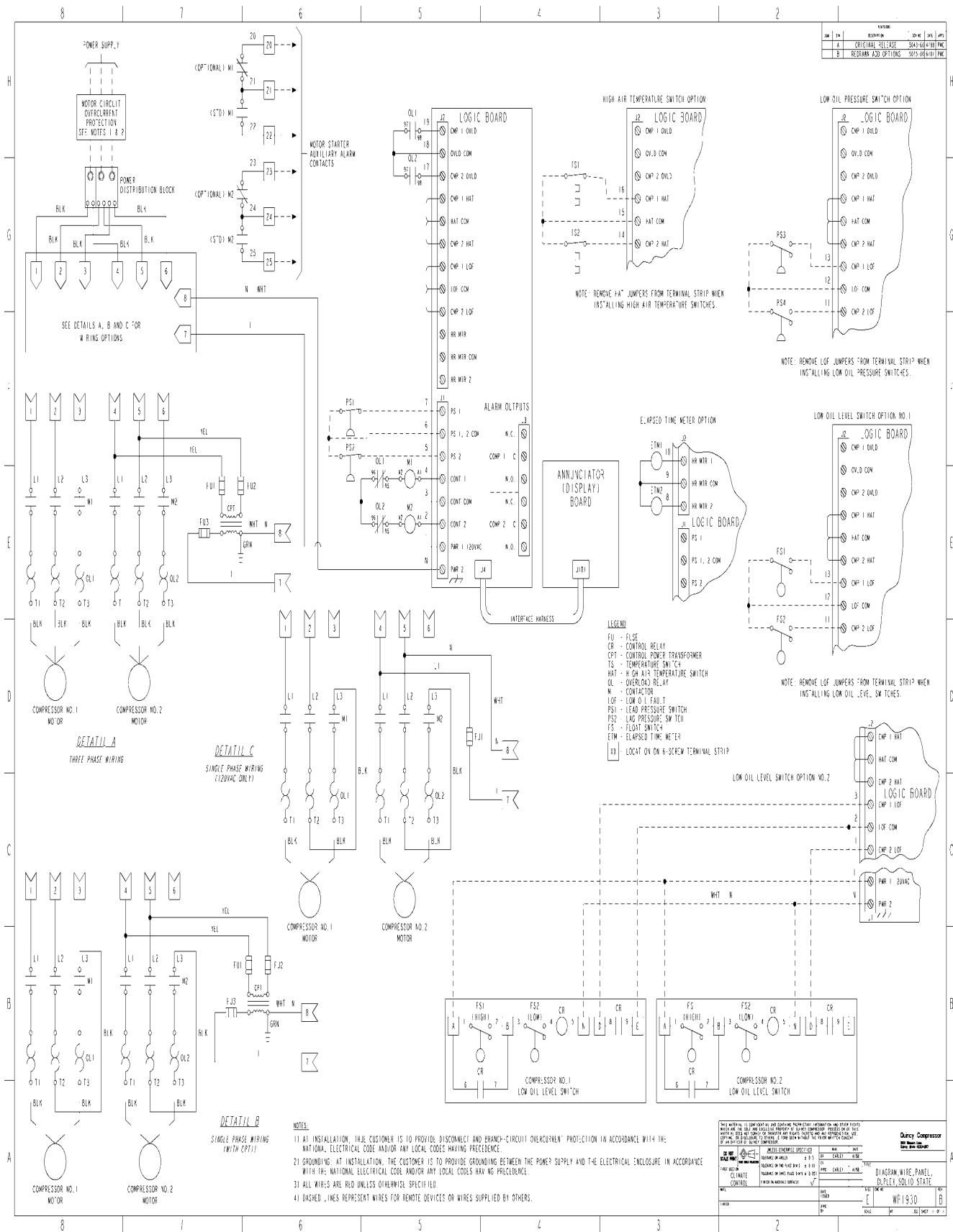

Wiring Diagram for Non-Combination Control Panel

QUINCY COMPRESSOR

STANDARD TERMS AND CONDITIONS

LEGAL EFFECT: Except as expressly otherwise agreed to in writing by an authorized representative of Seller, the following terms and conditions shall apply to and form a part of this order and any additional and/or different terms of Buyer's purchase order or other form of acceptance are rejected in advance and shall not become a part of this order.

The rights of Buyer hereunder shall be neither assignable nor transferable except with the written consent of Seller.

This order may not be canceled or altered except with the written consent of Seller and upon terms which will indemnify Seller against all loss occasioned thereby. All additional costs incurred by Seller due to changes in design or specifications, modification of this order or revision of product must be paid for by Buyer.

In addition to the rights and remedies conferred upon Seller by this order, Seller shall have all rights and remedies conferred at law and in equity and shall not be required to proceed with the performance of this order if Buyer is in default in the performance of such order or of any other contract or order with seller.

TERMS OF PAYMENT: Unless otherwise specified in the order acknowledgment, the terms of payment shall be 1% 15, net forty-five (45) days after shipment. These terms shall apply to partial as well as complete shipments. If any proceeding be initiated by or against Buyer under any bankruptcy or insolvency law, or in the judgment of Seller the financial condition of Buyer, at the time the equipment is ready for shipment, does not justify the terms of payment specified, Seller reserves the right to require full payment in cash prior to making shipment. If such payment is not received within fifteen (15) days after notification of readiness for shipment, Seller may cancel the order as to any unshipped item and require payment of its reasonable cancellation charges.

If Buyer delays shipment, payments based on date of shipment shall become due as of the date when ready for shipment. If Buyer delays completion of manufacture, Seller may elect to require payment according to percentage of completion. Equipment held for Buyer shall be at Buyer's risk and storage charges may be applied at the discretion of Seller.

Accounts past due shall bear interest at the highest rate lawful to contract for but if there is no limit set by law, such interest shall be eighteen percent (18%). Buyer shall pay all cost and expenses, including reasonable attorney's fees, incurred in collecting the same, and no claim, except claims within Seller's warranty of material or workmanship, as stated below, will be recognized unless delivered in writing to Seller within thirty (30) days after date of shipment.

TAXES: All prices exclude present and future sales, use, occupation, license, excise, and other taxes in respect of manufacture, sales or delivery, all of which shall be paid by Buyer unless included in the purchase price at the proper rate or a proper exemption certificate is furnished.

ACCEPTANCE: All offers to purchase, quotations and contracts of sales are subject to final acceptance by an authorized representative at Seller's plant.

DELIVERY: Except as otherwise specified in this quotation, delivery will be F. O. B. point of shipment. In the absence of exact shipping instruction, Seller will use its discretion regarding best means of insured shipment. No liability will be accepted by Seller for so doing. All transportation charges are at Buyer's expense. Time of delivery is an estimate only and is based upon the receipt of all information and necessary approvals. The shipping schedule shall not be construed to limit seller in making commitments for materials or in fabricating articles under this order in accordance with Seller's normal and reasonable production schedules.

Seller shall in no event be liable for delays caused by fires, acts of God, strikes, labor difficulties, acts of governmental or military authorities, delays in transportation or procuring materials, or causes of any kind beyond Seller's control. No provision for liquidated damages for any cause shall apply under this order. Buyer shall accept delivery within thirty (30) days after receipt of notification of readiness for shipment. Claims for shortages will be deemed to have been waived if not made in writing with ten (10) days after the receipt of the material in respect of which any such shortage is claimed. Seller is not responsible for loss or damage in transit after having received "In Good Order" receipt from the carrier. All claims for loss or damage in transit should be made to the carrier.

TITLE & LIEN RIGHTS: The equipment shall remain personal property, regardless of how affixed to any realty or structure. Until the price (including any notes given therefore) of the equipment has been fully paid in cash, Seller shall, in the event of Buyer's default, have the right to repossess such equipment.

PATENT INFRINGEMENT: If properly notified and given an opportunity to do so with friendly assistance, Seller will defend Buyer and the ultimate user of the equipment from any actual or alleged infringement of any published United States patent by the equipment or any part thereof furnished pursuant hereto (other than parts of special design, construction, or manufacture specified by and originating with Buyer), and will pay all damages and costs awarded by competent court in any suit thus defended or of which it may have had notice and opportunity to defend as aforesaid.

STANDARD WARRANTY: Seller warrants that products of its own manufacture will be free from defects in workmanship and materials under normal use and service for the period specified in the product instruction manual. Warranty for service parts will be Ninety (90) days from date of factory shipment. Electric Motors, gasoline and diesel engines, electrical apparatus and all other accessories, components and parts not manufactured by Seller are warranted only to the extent of the original manufacturer's warranty.

Notice of the alleged defect must be given to the Seller, in writing with all identifying details including serial number, type of equipment and date of purchase within thirty (30) days of the discovery of the same during the warranty period.

Seller's sole obligation on this warranty shall be, at its option, to repair or replace or refund the purchase price of any product or part thereof which proves to be defective. If requested by Seller, such product or part thereof must be promptly returned to seller, freight prepaid, for inspection.

Seller warrants repaired or replaced parts of its own manufacture against defects in materials and workmanship under normal use and service for ninety (90) days or for the remainder of the warranty on the product being repaired.

This warranty shall not apply and Seller shall not be responsible or liable for:

- (a) Consequential, collateral or special losses or damages;
- (b) Equipment conditions caused by fair wear and tear, abnormal conditions of use, accident, neglect or misuse of equipment, improper storage or damage resulting during shipping;
- (c) Deviation from operating instructions, specifications or other special terms of sale;
- (d) Labor charges, loss or damage resulting from improper operation, maintenance or repairs made by person(s) other than Seller or Seller's authorized service station.

In no event shall Seller be liable for any claims whether arising from breach of contract or warranty or claims of negligence or negligent manufacture in excess of the purchase price.

THIS WARRANTY IS THE SOLE WARRANTY OF SELLERS AND ANY OTHER WARRANTIES, WHETHER EXPRESS OR IMPLIED IN LAW OR IMPLIED IN FACT, INCLUDING ANY WARRANTIES OF MERCHANTABILITY AND FITNESS FOR PARTICULAR USE ARE HEREBY SPECIFICALLY EXCLUDED.

LIABILITY LIMITATIONS: Under no circumstances shall the Seller have any liability for liquidated damages or for collateral, consequential or special damages or for loss of profits, or for actual losses or for loss of production or progress of construction, whether resulting from delays in delivery or performance, breach of warranty, negligent manufacture or otherwise.

ENVIRONMENTAL AND OSHA REQUIREMENTS: At the time of shipment of the equipment from the factory, Quincy Compressor / Ortman Fluid Power will comply with the various Federal, State and local laws and regulations concerning occupational health and safety and pollution. However, in the installation and operation of the equipment and other matters over which the seller has no control, the Seller assumes no responsibility for compliance with those laws and regulations, whether by the way of indemnity, warranty or otherwise.

June 30, 2003



an EnPro Industries company

Reciprocating / Systems: 217.222.7700
Air Master 217.277.0270
E-mail: info@quincycompressor.com
Website: quincycompressor.com
quincyairmaster.com



© 2006 Quincy Compressor, an EnPro Industries company
All Rights Reserved. Litho in U.S.A.