

Operator's Manual

SULLAIR® REFRIGERATION

C SERIES COMPRESSOR PACKAGE
BUILT PRIOR TO JUNE, 1991

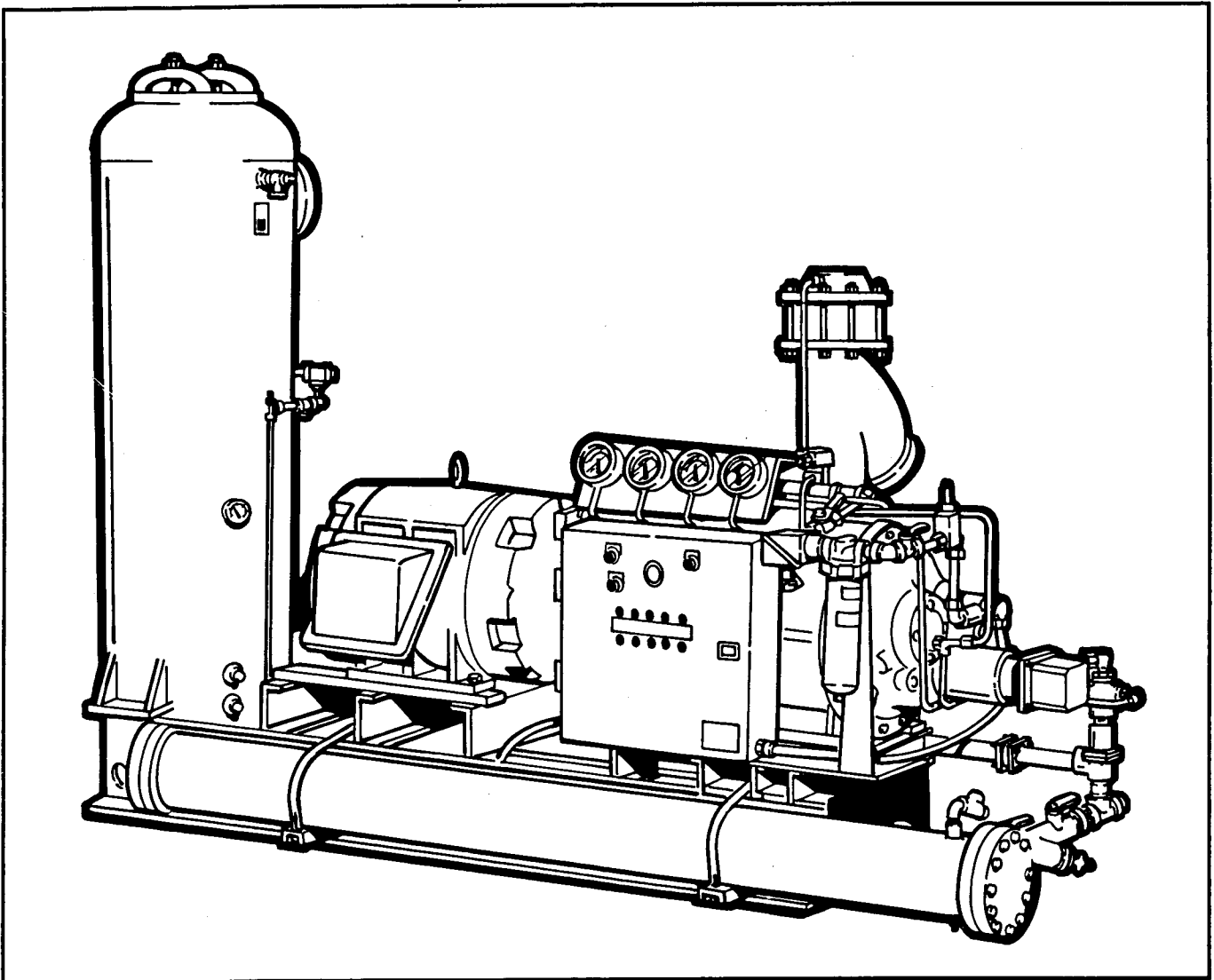

Part Number 252666
©Sullair Corporation, 1991
Effective 3/91

STATEMENT OF WARRANTY

Sullair Corporation ("Sullair") warrants that, under normal use and service, if properly stored, handled, operated and maintained, its bare refrigeration air end for a period of thirty (30) months from the date of shipment of the package or twenty-four (24) months from date of start-up, whichever occurs first; be free of defects in design and workmanship; whereas, repair of defects appearing in the package components shall be limited to eighteen (18) months from the date of shipment of the package or twelve (12) months from the date of start-up, whichever occurs first. This warranty does not extend to any prime mover or other component which is covered by the original equipment manufacturer's warranty or may be furnished by the customer. Should any such defect become apparent within such time, and written notice of each and every such defect is promptly provided to Sullair, and Sullair reasonably determines that any such Product is defective in material or workmanship, Sullair will, at its option, replace or repair such Product. Sullair's obligation with respect to such Product shall be limited to repair or replacement, F.O.B. Sullair's place of business, without any further expense to Sullair, and except as expressly provided herein, Sullair shall not in any event be liable for any other labor, transportation, installation, adjustment or other expenses which may arise in connection with such Product. Any misuse or abuse of the Product(s) voids this limited warranty.

The Sullair warranty does not extend to Products not assembled by Sullair. As to Products assembled by others including the driver (whether engine, turbine or electric motor), Purchaser shall be entitled to proceed only upon the terms of that particular manufacturer's warranty. The Sullair warranty does not apply to defects in materials provided by Purchaser or design stipulated by Purchaser.

Used Products, and Products not assembled by Sullair, are sold AS IS with no representation or warranty, and ALL WARRANTIES OF QUALITY, WRITTEN, ORAL OR IMPLIED, other than may be expressly agreed to by Sullair in writing, INCLUDING WITHOUT LIMITATION, WARRANTIES OF MERCHANTABILITY OR FITNESS, ARE HEREBY DISCLAIMED.

IN NO EVENT SHALL SULLAIR BE LIABLE FOR SPECIAL, INDIRECT, INCIDENTAL OR CONSEQUENTIAL DAMAGES however arising whether in warranty, strict liability, tort, negligence or otherwise, including but not limited to loss of profits of revenue, loss of total or partial use of the Products, facilities or services, downtime costs, or claims of Purchaser for such or other damages whether on account of Products furnished hereunder or delays in delivery thereof of services performed upon or with respect to such Products. Sullair's liability on any claim whether in warranty, strict liability, tort, negligence or otherwise for any loss or damage arising out of, connected with, or resulting from this warranty or the performance or breach thereof, or from the design, manufacture, sale, delivery, resale, repair, replacement, installation, technical direction of installation, inspection, servicing, operation or use of any Product covered by or furnished under this warranty shall in no case exceed the purchase price allowable to the Product or part thereof which give rise to the claim. Notice of claims against Sullair hereunder for any reason, including breach of warranty, must be made to Sullair in writing within forty-eight (48) hours of discovery to afford Sullair an opportunity to make a prompt investigation of surrounding facts and mitigate any damage which might ensue, should it be determined to be Sullair's responsibility. Failure to give such notice to Sullair shall constitute a waiver by Purchaser of any right later to assert such a claim.

Any cause of action against Sullair arising out of or relating to the warranty or the performance hereof shall expire unless brought within one (1) year of the time of accrual thereof.

THE FOREGOING LIMITED WARRANTY IS EXCLUSIVE AND IN LIEU OF ALL OTHER WARRANTIES, EXPRESSED OR IMPLIED, INCLUDING BUT NOT LIMITED TO ANY WARRANTY OF MERCHANTABILITY OR FITNESS FOR A PARTICULAR PURPOSE.

SULLAIR CORPORATION
A Subsidiary Of Sundstrand Corporation
Michigan City, Indiana 46360

KEEP YOUR MACHINE IN TOP
OPERATING CONDITION
USE

GENUINE

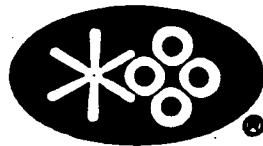

SULLAIR®

SERVICE PARTS

CONTACT YOUR NEAREST SULLAIR
DISTRIBUTOR OR CALL 1-800-348-2722



Sullair Corporation
Subsidiary of Sundstrand Corporation
3700 E. Michigan Blvd.
Michigan City, IN 46390-9990

Phone (219) 879-5451
Telex 4946922

PRODUCT SAFETY POLICY

MAY 15, 1984

It is Sullair Corporation's policy to produce and market the best product available commensurate with safety and health needs of the customer.

Sullair's objective is to furnish a product that is safe for its designed and intended use. It is Sullair's corporate desire that no Sullair product be the direct cause of an accident when used for its intended application.

Product safety shall be assured through systematic application of sound engineering and management principles in the conception, design, development, testing, manufacturing, sale and servicing of all products.

Adequate instructions and cautionary labels shall be utilized.

This is a reaffirmation of a policy existing at Sullair since its origin.

Robert T. Bloomberg
President and Chief
Executive Officer

SEMINAR TRAINING

Sullair Seminars are 2-day courses that provide hands-on instruction in the proper operation, maintenance and service of Sullair Refrigeration Compressors. Seminars are presented at regular intervals throughout the year at a dedicated training facility at Sullair's corporate headquarters in Michigan City, Indiana.

Instruction includes discussion of the function and installation of Sullair service parts, troubleshooting of the most common problems, and actual equipment operation. The seminars are recommended for maintenance and service personnel.

For detailed course outlines, schedule and cost information contact:

Sullair Corporate Training Department
1-800-348-2722 or (219) 879-5451 (ext. 1867)

- Or Write -

Sullair Corporation
3700 E. Michigan Blvd.
Michigan City, IN 46360
Attn: Service Training Department

TABLE OF CONTENTS

Section 1 SAFETY

PAGE	
1	1.1 GENERAL
1	1.2 PERSONAL PROTECTIVE EQUIPMENT
1	1.3 PRESSURE RELEASE
1	1.4 FIRE AND EXPLOSION
1	1.5 MOVING PARTS
2	1.6 HOT SURFACES, SHARP EDGES AND SHARP CORNERS
2	1.7 TOXIC AND IRRITATING SUBSTANCES
2	1.8 ELECTRICAL SHOCK
2	1.9 LIFTING

Section 2 DESCRIPTION

3	2.1 INTRODUCTION
3	2.2 THE PACKAGE
4	2.3 THE COMPRESSOR
4	2.4 THE CAPACITY CONTROL SYSTEM
6	2.5 THE LUBRICATION SYSTEM
27	2.6 THE ELECTRICAL CONTROL SYSTEM
41	2.7 CAPACITY CONTROLS

Section 3 SPECIFICATIONS

44	3.1 GENERAL SPECIFICATIONS
44	3.2 MODEL AND SERIAL NUMBERS
44	3.3 OPERATING LIMITS AND SWITCH SETTINGS
45	3.4 OIL SPECIFICATIONS
48	3.5 MOTOR SPECIFICATIONS

Section 4 INSTALLATION

49	4.1 GENERAL
49	4.2 START-UP SERVICE OUTLINE
49	4.3 STORAGE
49	4.4 FOUNDATION AND RIGGING
50	4.5 REFRIGERANT PIPING
50	4.6 COOLING WATER SUPPLY REQUIREMENTS
53	4.7 COOLING REFRIGERANT SUPPLY REQUIREMENTS
53	4.8 PRESSURE TEST FOR LEAKS
57	4.9 SYSTEM EVACUATION
58	4.10 COUPLING ALIGNMENT

Section 1 SAFETY

1.1 GENERAL

Sullair® Corporation designs and manufactures all of its products so they can be operated safely. However, the responsibility for safe operation rests with those who use and maintain these products. The following safety precautions are offered as a guide which, if conscientiously followed, will minimize the possibility of accidents throughout the useful life of this equipment.

The compressor should be operated only by those who have been trained and delegated to do so, and who have read and understood this Operator's Manual. Failure to follow the instructions, procedures and safety precautions in this manual can result in accidents and injuries.

NEVER start the compressor unless it is safe to do so. **DO NOT** attempt to operate the compressor with a known unsafe condition. Tag the compressor and render it inoperative by disconnecting and locking out all power at source or otherwise disabling its prime mover so others, who may not know of the unsafe condition, cannot attempt to operate it until the condition is corrected.

Install, use and operate the compressor only in full compliance with all pertinent OSHA regulations and all applicable Federal, State, and Local codes, standards and regulations.

DO NOT modify the compressor and/or controls in any way except with written factory approval.

While not specifically applicable to all types of compressors with all types of prime movers, most of the precautionary statements contained herein are applicable to most compressors and the concepts behind these statements are generally applicable to all compressors.

1.2 PERSONAL PROTECTIVE EQUIPMENT

Prior to installing or operating the compressor, owners, employers, and users should become familiar with, and comply with, all applicable OSHA regulations, Refrigerant and Oil Material Safety Data Sheets and any applicable Federal, State and Local codes, standards, and regulations relative to personal protective equipment, such as eye and face protective equipment, respiratory protective equipment, equipment intended to protect the extremities, protective clothing, protective shields and barriers and electrical protective equipment, as well as noise exposure, administrative and/or engineering controls and/or personal hearing protective equipment.

1.3 PRESSURE RELEASE

A. All relief valves are to be piped to an exhaust with sizing and locations per Code requirements and all other Federal, State and local codes.

B. The compressor is supplied with a pump-out valve. This shall be used to reduce the pressure in the compressor and preferably should be piped to

a pump-out compressor. If not piped to a pump-out compressor, provisions must be made to vent the gases in accordance with the required codes.

C. Whenever working on any piping, tubing or other connections, make sure that the compressor is blown down to atmospheric pressure. Even when blown down, caution must be followed when loosening connections as localized pressure pockets can still be present.

1.4 FIRE AND EXPLOSION

A. Clean up spills of lubricant or other combustible substances immediately, when such spills occur.

B. Shut off the compressor and allow it to cool. Then keep sparks, flames and other sources of ignition away and **DO NOT** permit smoking in the vicinity when checking or adding lubricant.

C. Disconnect and lock out all power at source prior to attempting any repairs or cleaning of the compressor.

D. Keep electrical wiring, including all terminals and pressure connectors, in good condition. Replace any wiring that has cracked, cut, or otherwise degraded insulation, or terminals that are worn, discolored or corroded. Keep all terminals and pressure connectors clean and tight.

E. Keep grounded and/or conductive objects such as tools away from exposed live electrical parts such as terminals to avoid arcing.

F. Keep suitable fully charged Class BC or ABC fire extinguisher or extinguishers nearby when servicing and operating the compressor.

G. Keep oily rags, trash, leaves, litter or other combustibles out of and away from the compressor.

H. **DO NOT** operate the compressor without proper flow of cooling air or water or with inadequate flow of lubricant or with degraded lubricant.

I. **DO NOT** attempt to operate the compressor in any classification of hazardous environment unless the compressor has been specially designed and manufactured for that duty.

1.5 MOVING PARTS

A. Keep hands, arms and other parts of the body and also clothing away from couplings, fans and other moving parts.

B. **DO NOT** attempt to operate the compressor with the coupling or other guards removed.

C. Wear snug fitting clothing and confine long hair when working around this compressor, especially when exposed to hot or moving parts.

D. Keep access doors, if any, closed except when making repairs or adjustments.

E. Make sure all personnel are out of and/or clear of the compressor prior to attempting to start or operate it.

Section 1 SAFETY

F. Disconnect and lock out all power at source and verify at the compressor that all circuits are de-energized to minimize the possibility of accidental start-up or operation, prior to attempting repairs or adjustments. This is especially important when compressors are remotely controlled.

G. Keep hands, feet, floors, controls and walking surfaces clean and free of oil, water or other liquids to minimize the possibility of slips and falls.

1.6 HOT SURFACES, SHARP EDGES AND SHARP CORNERS

A. Avoid bodily contact with hot oil, hot coolant, hot surfaces and sharp edges and corners.

B. Keep all parts of the body away from all points of gas discharge.

C. Wear personal protective equipment including gloves and head covering when working in, on or around the compressor.

D. Keep a first aid kit handy. Seek medical assistance promptly in case of injury. **DO NOT** ignore small cuts and burns as they may lead to infection.

1.7 TOXIC AND IRRITATING SUBSTANCES

A. Operate the compressor only in open or adequately ventilated areas.

B. Coolants and lubricants used in this compressor are typical of the industry. Care should be taken to avoid accidental ingestion and/or skin contact. In the event of ingestion, seek medical treatment promptly. Wash with soap and water in the event of skin contact.

1.8 ELECTRICAL SHOCK

A. This compressor should be installed and maintained in full compliance with all applicable Federal, State and Local codes, standards and regulations, including those of the National Electrical Code, and also including those relative to equipment grounding conductors, and only by personnel that are trained, qualified and delegated to do so.

B. Keep all parts of the body and any hand-held tools or other conductive objects away from exposed live parts of electrical system. Maintain dry footing, stand on insulating surfaces and **DO NOT** contact any other portion of the compressor when making adjustments or repairs to exposed live parts of the electrical system. Make all such adjustments or repairs with one hand only, so as to minimize the possibility of creating a current path through the heart.

C. Attempt repairs in clean, dry and well lighted and ventilated areas only.

D. **DO NOT** leave the compressor unattended with open electrical enclosures. If necessary to

do so, then disconnect, lock out and tag all power at source so others will not inadvertently restore power.

E. Disconnect, lock out, and tag all power at source prior to attempting repairs or adjustments to rotating machinery and prior to handling any ungrounded conductors.

1.9 LIFTING

A. Inspect points of attachment for cracked welds and for cracked, bent, corroded or otherwise degraded members and for loose bolts or nuts prior to lifting.

B. Make sure entire lifting, rigging and supporting structure has been inspected, is in good condition and has a rated capacity of at least the weight of the compressor. If you are unsure of the weight, then weigh compressor before lifting.

C. Make sure lifting hook has a functional safety latch or equivalent, and is fully engaged and latched on the bail or slings.

D. Use guide ropes or equivalent to prevent twisting or swinging of the compressor once it has been lifted clear of the ground.

E. **DO NOT** attempt to lift in high winds.

F. Keep all personnel out from under and away from the compressor whenever it is suspended.

G. Lift compressor no higher than necessary.

H. Keep lift operator in constant attendance whenever compressor is suspended.

I. Set compressor down only on level surfaces capable of safely supporting at least its weight and its loading unit.

J. When moving compressors by forklift truck, utilize fork pockets if provided. Otherwise, utilize pallet if provided. If neither fork pockets or pallet are provided, then make sure compressor is secure and well balanced on forks before attempting to raise or transport it any significant distance.

K. Make sure forklift truck forks are fully engaged and tipped back prior to lifting or transporting the compressor.

L. Forklift no higher than necessary to clear obstacles at floor level and transport and corner at minimum practical speeds.

M. Make sure pallet-mounted compressors are firmly bolted or otherwise secured to the pallet prior to attempting to forklift or transport them. **NEVER** attempt to forklift a compressor that is not secured to its pallet, as uneven floors or sudden stops may cause the compressor to tumble off, possibly causing serious injury or property damage in the process.

Section 2 DESCRIPTION

2.1 INTRODUCTION

Your new Sullair Refrigeration Screw compressor will provide you with improved reliability and reduced maintenance if installed, started, operated, and serviced according to this manual. As with all industrial compressors, only trained and authorized personnel should install, operate and maintain the Sullair compressor. Take special note of items marked "important", "danger", or "warning", as overlooking these can lead to compressor damage and/or hazardous situations. Should you have any questions which are not answered in this manual, contact the Sullair Refrigeration Department or their agents for assistance.

To ensure correct application the compressor package must be connected to a system designed and installed in accordance with good industrial practices such as described in the ASHRAE (American Society of Heating, Refrigerating, and Air Conditioning Engineers) "Systems Handbook", and the IAR (International Institute of Ammonia Refrigeration) "Equipment Design and Installation of Ammonia Mechanical Refrigeration System". System valves and controls should be installed according to the recommendations of the manufacturers or suppliers.

Immediately upon arrival of your new Sullair compressor, unpack all the crates and boxes and check the items against shipping lists for any possible shortages. Examine the compressor, package components and loose items for possible damage in transit. Notify the carrier of any shortages or damages and enter the appropriate claim with them.

Prior to proceeding any further, familiarize yourself with the compressor package components with the aid of Figures 2-1 and 2-2.

2.2 THE PACKAGE

Refer to Figures 2-1 and 2-2 for arrangement. The compressor package is factory-assembled and includes the following equipment:

- Sullair screw compressor unit
- Electric motor
- Coupling and guard
- Three stage oil separator
- Lubrication system with oil separator with either a shell and tube water-cooled oil cooler, shell and tube thermosiphon oil cooler, or a high pressure liquid refrigerant injection oil cooling system
- Suction strainer and suction check valve.
- Electrical Control System
- Oil pump

Figure 2-1 C Series Water-Cooled Rotary Screw Refrigeration Compressor

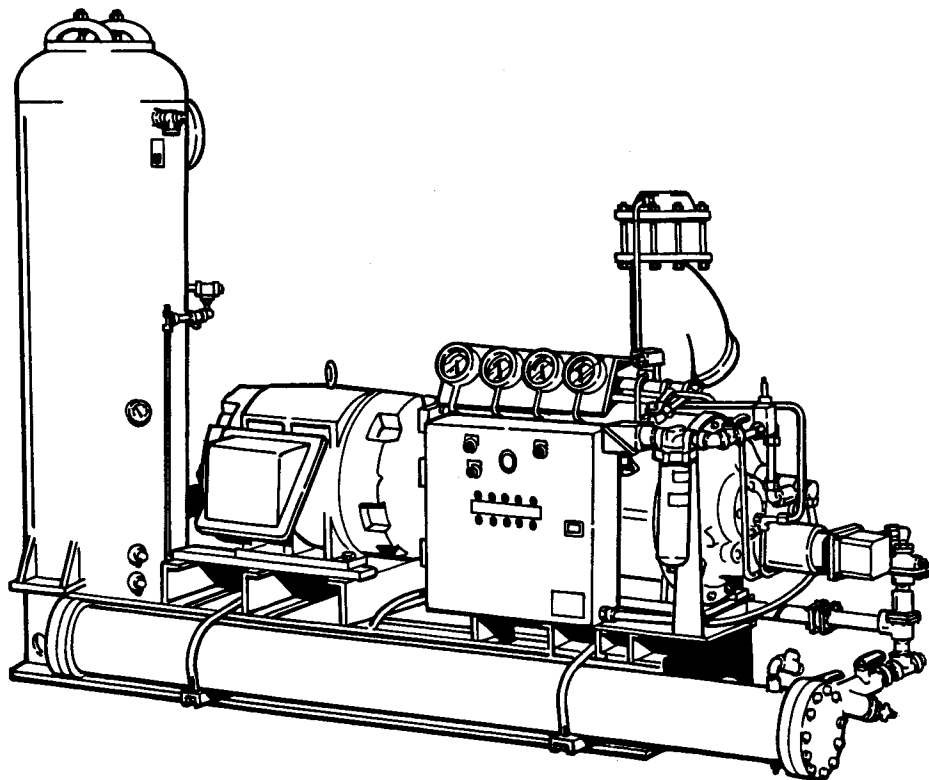

Section 2 DESCRIPTION

Figure 2-2 C Series Liquid Injection-Cooled Rotary Screw Refrigeration Compressor

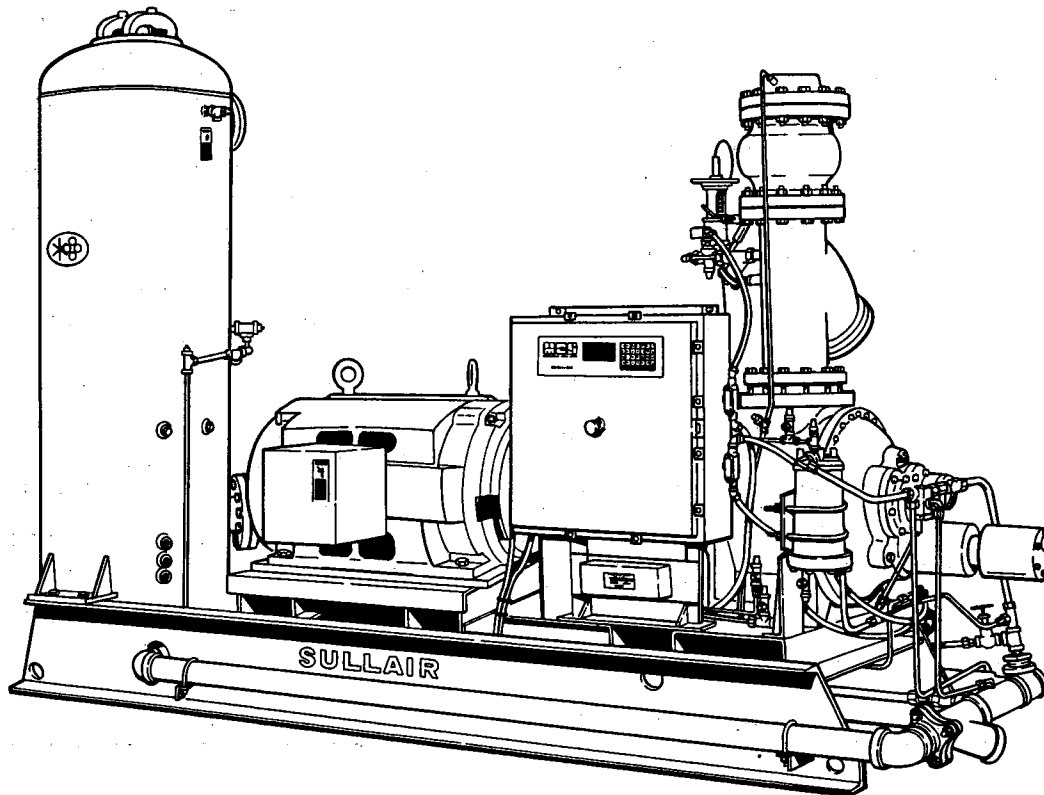

- 150 PSI (1.0MPa) booster and 300 PSI (2.1MPa) high stage design.

2.3 THE COMPRESSOR

The U.S. made Sullair Refrigeration Screw Compressor is an advanced design incorporating many years of experience in the screw compressor field. The single stage, positive displacement, pulse-free compressor includes the following design features:

- Non-symmetrical rotor profile
- 350 PSI (2.4 MPa) design casting
- Double wall, circular cast stator
- Internal, pilot operated hydraulic capacity control slide valve.
- Hard chrome plated journals and steel backed babbit main bearings.
- Angular contact ball thrust bearings.
- Positive displacement shaft driven oil pump.
- Oil flooded, carbon face shaft seal.

Oil is injected into the compressor unit and mixes directly with the refrigerant as the rotors turn, compressing the gas. The oil has three functions:

- As a coolant, it controls the rise of the gas temperature associated with the heat of compression.

- As a sealant, it seals the leakage paths between each rotor and the stator and also between the two rotors.
- As a lubricant, it acts as a lubricating film between the rotors allowing the male rotor to directly drive the female rotor.

The oil is separated from the refrigerant after the refrigerant/oil mixture is discharged from the compressor unit. The refrigerant passes into the system, and the oil is cooled in preparation for re-injection into the compressor.

The compressor capacity or displacement is varied according to the suction pressure by sliding a valve, which is a movable cusp section of the stator, in the rotor bore. When this slide valve is open, it allows the gas to return to suction rather than be compressed.

2.4 THE CAPACITY CONTROL SYSTEM

Refer to Figure 2-3. The capacity control slide valve is positioned by a single acting piston in a cylinder which uses hydraulic force to unload the compressor. Because of the gas pressure difference across the slide valve (suction on one side and discharge on the other) there is a large force tending to close the valve or to load the compressor. By the addition of high pressure oil behind the piston, the valve can be moved to any desired

Section 2 DESCRIPTION

Figure 2-3 Capacity Control Slide Valve

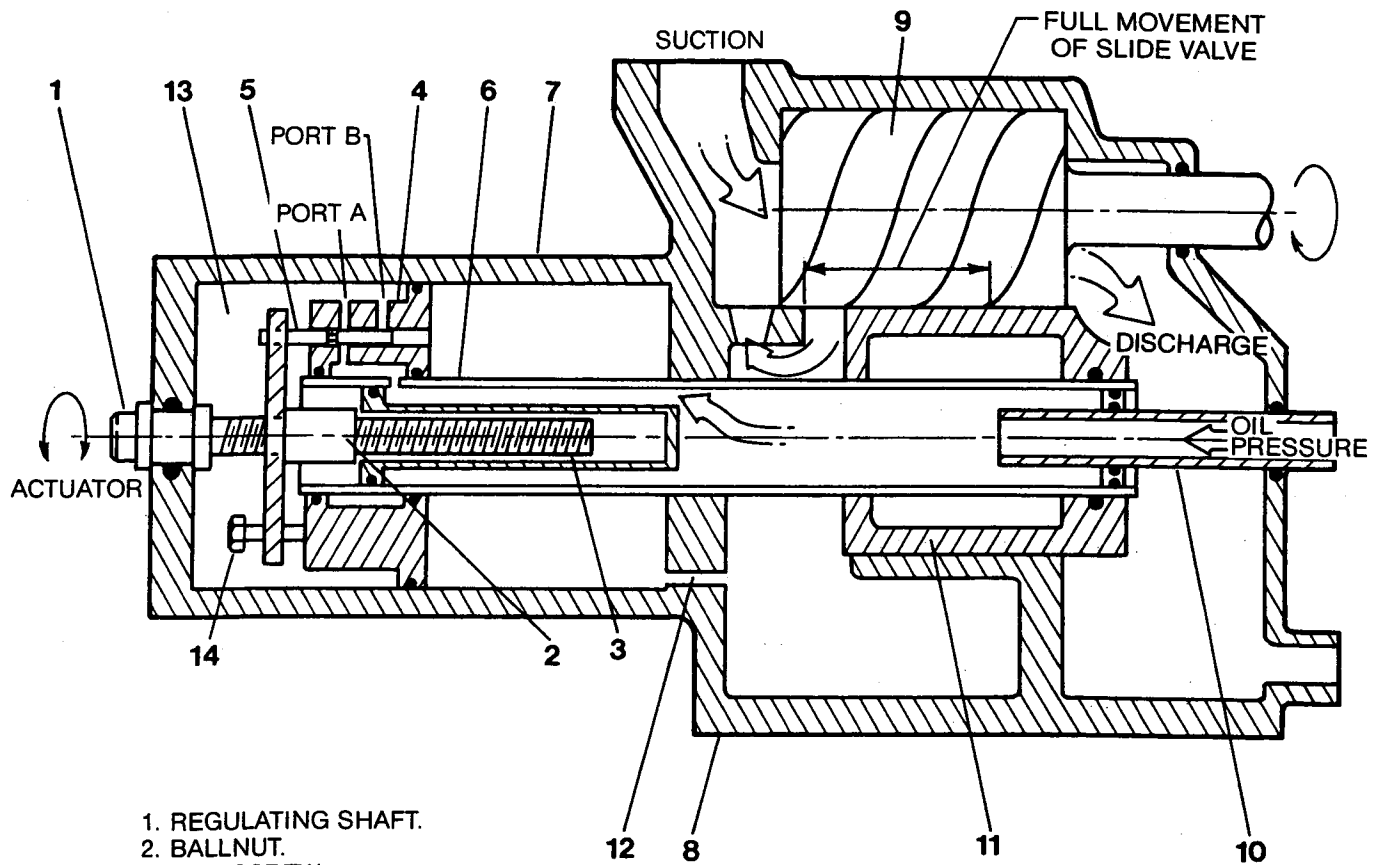

1. REGULATING SHAFT.
2. BALLNUT.
3. BALLSCREW.
4. PISTON WITH CHANNELS & PILOT VALVE BORE.
5. PILOT VALVE.
6. PISTON ROD.
7. CYLINDER.
8. COMPRESSOR HOUSING.
9. COMPRESSOR ROTORS.
10. HIGH PRESSURE OIL SUPPLY PIPE.
11. SLIDE VALVE.
12. CHANNEL BETWEEN LOW PRESSURE SIDE & CYLINDER.
13. OUTBOARD CHAMBER OF HYDRAULIC CYLINDER.
14. RETAINING SHOULDER BOLT.

LOAD ←
UNLOAD →

Not to scale. Schematic only.
Refer to Figure 6-16 for actual detail.

Section 2

DESCRIPTION

position in the unloading direction. By draining oil from the cylinder, the compressor can be loaded since the gas force will close the valve.

The Sullair capacity control system uses a pilot valve (5) to control the oil flow to position the slide valve. As the pilot valve is moved forward in the unloading direction the high pressure oil supply port A is opened allowing high pressure oil to flow from the oil supply tube (10) to the outboard chamber (13). This allows the oil to force the piston (4) and valve assembly (11) in the unloading direction.

As the pilot valve is moved in the loaded or reverse direction, the drain port B allows the oil to drain from the outboard chamber (13) and through the opening (12) from the low pressure side of the piston back to compressor suction. This loads the compressor as the gas force moves the piston (4) and valve assembly (11) to the loaded position.

Since the slide valve follows the pilot valve, the capacity can be regulated by positioning the pilot valve.

The pilot valve is positioned by a single ball nut (2) and ball screw assembly (3) which is rotated by a small motor in the electric valve actuator (EVA) mounted on the end of the hydraulic cylinder and connected to the regulator shaft (1). An electrical signal is obtained from a suction pressure or other sensor and translated through the EVA system into a clockwise or counterclockwise rotation of the ball screw. (See Section 2.6 for a detailed description of the electrical aspects of the capacity control system).

2.5 THE LUBRICATION SYSTEM

The standard lubrication schematics for the shell and tube cooled and liquid injection-cooled packages are shown in Figures 2-4 through 2-7.

The oil (from injection and the bearings) leaves the compressor discharge in a refrigerant/oil mixture and is separated from the refrigerant in the three stage oil separator. Sight glasses are installed in the sump portion of the separator to indicate oil level. A thermostatically controlled oil heater is installed in the oil separator to maintain oil temperature and prevent refrigerant condensation when the compressor is not running.

The oil is cooled with either water or refrigerant in a shell and tube oil cooler or by injection of high pressure liquid refrigerant directly into the compressor near the discharge port. In the water cooled system a valve senses oil temperature and varies the flow of water into the oil cooler to maintain a constant oil temperature. In the refrigerant-cooled system (thermosiphon), a 3-way valve senses mixed oil temperature and maintains

the oil temperature by mixing cooled oil from the cooler with hot oil from the separator sump. The liquid injection-cooled system includes a strainer, a low discharge temperature switch, a solenoid valve and a refrigerant regulating valve. When the discharge temperature rises above the low discharge temperature setting, the solenoid valve opens and feeds refrigerant to the refrigerant regulating valve. This refrigerant regulating valve senses the temperature in the discharge pipe and varies the flow of liquid refrigerant into the compressor to maintain a constant oil temperature. (A detailed description of the refrigerant injection-cooling system is in Section 4.7).

Oil for injection is circulated by the pressure difference between the oil reservoir in the oil separator which is at discharge pressure and the injection ports which are just above suction pressure. Before reaching the injection ports the oil is passed through a 100 mesh strainer.

The remainder of the oil is pumped by a gear pump driven directly off the female rotor shaft. It passes through a pressure relief valve and a very fine filter to the oil manifold. From the manifold it is distributed to the bearings, the capacity control slide valve, the shaft seal and to a pressure regulating valve. The oil pressure and oil temperature are monitored at the oil manifold.

The gas/oil mixture leaving the compressor discharge enters the oil separator/sump where the oil is separated. Sight glasses are installed in the sump portion of the separator to indicate oil level.

A thermostatically controlled oil heater is installed in the oil separator to maintain oil temperature when the compressor is not running. Oil cooling is accomplished by a shell and tube oil cooler for water and thermosiphon cooling or by direct injection of high pressure liquid refrigerant.

















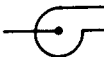

The water-cooled oil cooling system is furnished with a water regulating valve (shipped loose) which senses oil temperature and modulates the water flow to maintain oil temperature.

The thermosiphon oil cooling system is furnished with a 3-way thermostatically actuated control valve which bypasses hot oil around the cooler to maintain oil temperature.

The refrigerant-cooled system includes a strainer, low discharge temperature switch, solenoid valve and temperature control valve. Refrigerant is injected directly into the compressor near the discharge port. The low discharge temperature sensor is included to stop refrigerant flow at low discharge temperatures and to prevent refrigerant overfeed.

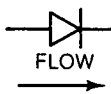
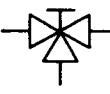
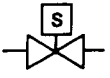
Section 2 DESCRIPTION

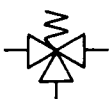
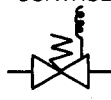
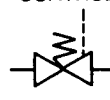
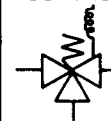
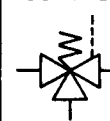
Figure 2-4 Legends for Figures 2-5 through 2-7

PRESSURE GAUGE 	TEMPERATURE GAUGE 	PRESSURE SWITCH 	TEMPERATURE SWITCH 	FILTER 	STRAINER 	ORIFICE 	SNUBBER 
PUMP 	COMPRESSOR 	MOTOR 	STOP VALVE 2 WAY 	GLOBE VALVE 	SIGHT GLASS 	CHECK VALVE 	STOP VALVE 3 WAY 
SOLENOID VALVE 	RELIEF VALVE 2 WAY 	RELIEF VALVE 2 WAY 	RELIEF VALVE 3 WAY 	REGULATING VALVE 2 WAY TEMPERATURE CONTROL 	REGULATING VALVE 2 WAY PRESSURE CONTROL 	REGULATING VALVE 3 WAY TEMPERATURE CONTROL 	REGULATING VALVE 3 WAY PRESSURE CONTROL 
ELECTRIC ACTUATOR 	DUPLEX VALVE 	INSIDE DASH-DOT LINE, INSTALLED AND/OR SUPPLIED BY CUSTOMER.					

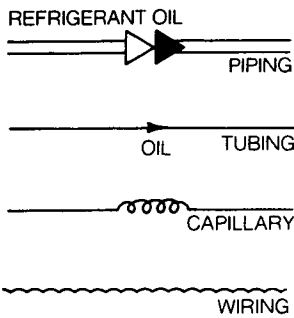

- X1 DISCHARGE TEMPERATURE
 - X2 DISCHARGE PRESSURE
 - X3 SUCTION PRESSURE
 - X4 SULLISTAGE INLET
 - X5 REFRIGERANT LIQUID INJECTION
 - X6 OIL TO BEARINGS-INLET END
 - X7 STATOR DRAIN
 - X8 OIL RETURN FROM MALE INLET BEARING / MALE BALANCE PISTON INLET
 - X9 OIL TO SHAFT SEAL
 - X10 OIL TO CAPACITY CONTROL VALVE ACTUATION
 - X11 OIL TO CAPACITY CONTROL VALVE LUBRICATION
 - X12 OIL TO MALE OUTLET BEARING
 - X13 OIL TO FEMALE OUTLET BEARING
 - X14 OIL INJECTION-MALE ROTOR
 - X15 OIL INJECTION-FEMALE ROTOR
 - X16 SHAFT SEAL DRAIN
- P NORMALLY PLUGGED

----- CONTROL TUBING

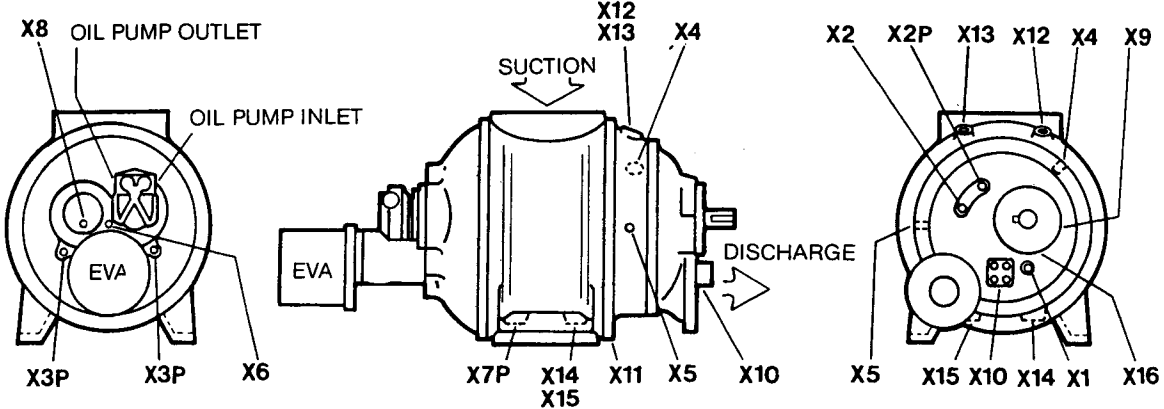

Section 2 DESCRIPTION

Figure 2-5A High Stage Water-Cooled Piping Schematic for Compressor Units Built Before 1-1-80

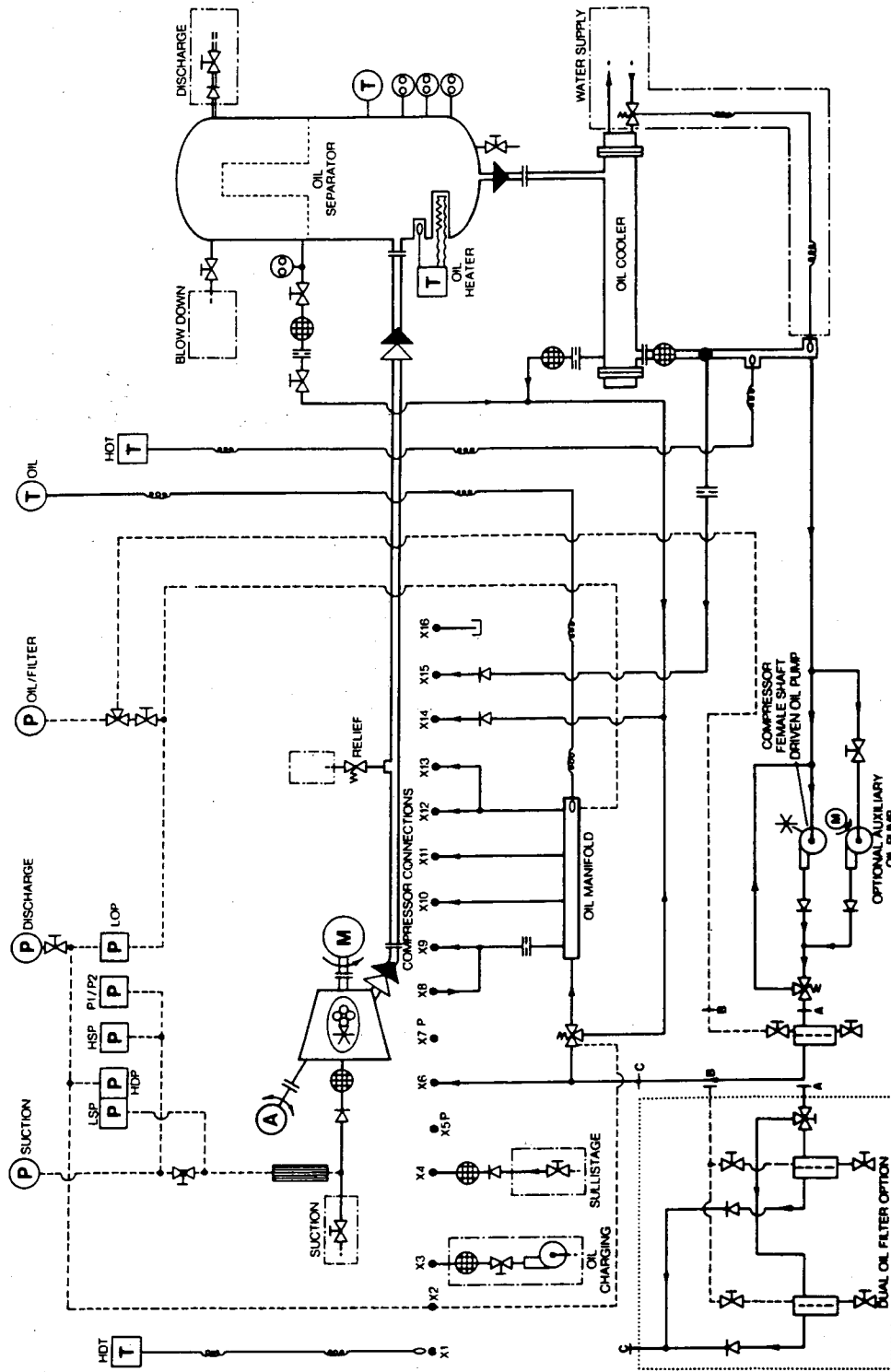

Section 2 DESCRIPTION

Figure 2-5B High Stage Water-Cooled Piping Schematic Compressor Units with 6XXXX-4XX Series Part Numbers

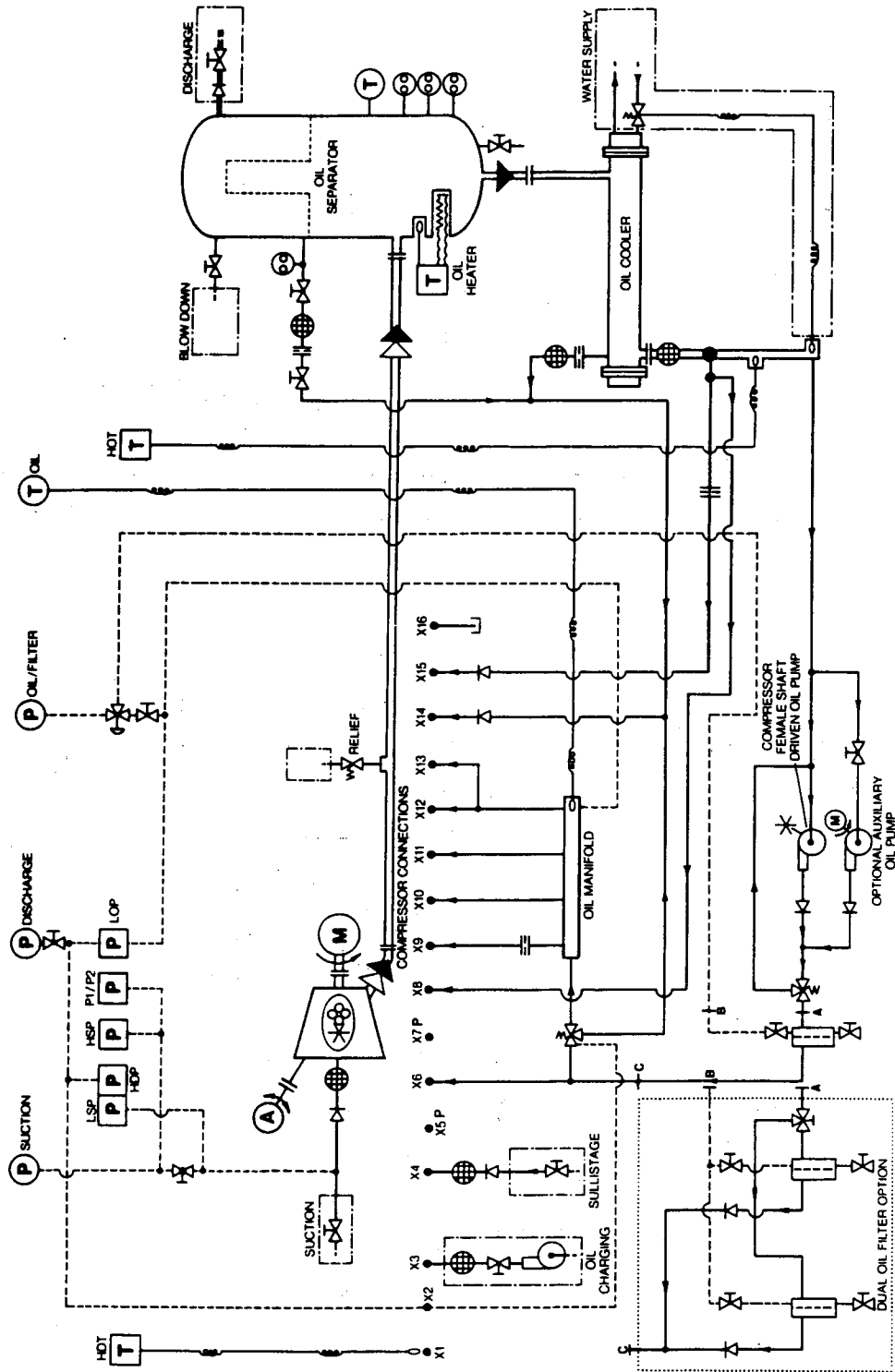

Section 2 DESCRIPTION

Figure 2-5C High Stage Water-Cooled Piping Schematic (C16 and C20) for Compressor Units with 6XXXX-5XX Series Part Numbers

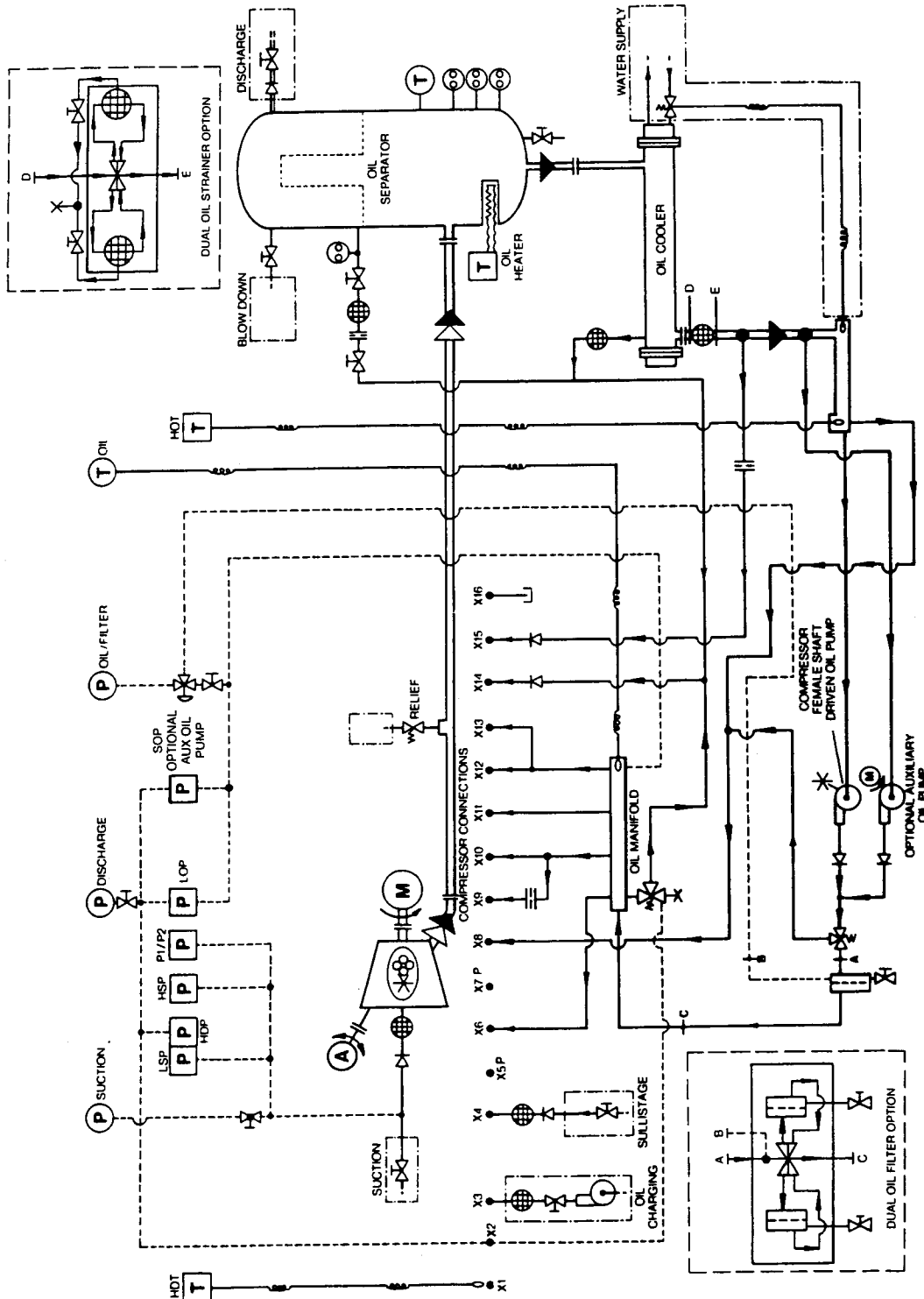

Section 2 DESCRIPTION

Figure 2-5D Booster Water-Cooled Piping Schematic (C16 and C20) for Compressor Units with 6XXXX-5XX Series Part Numbers

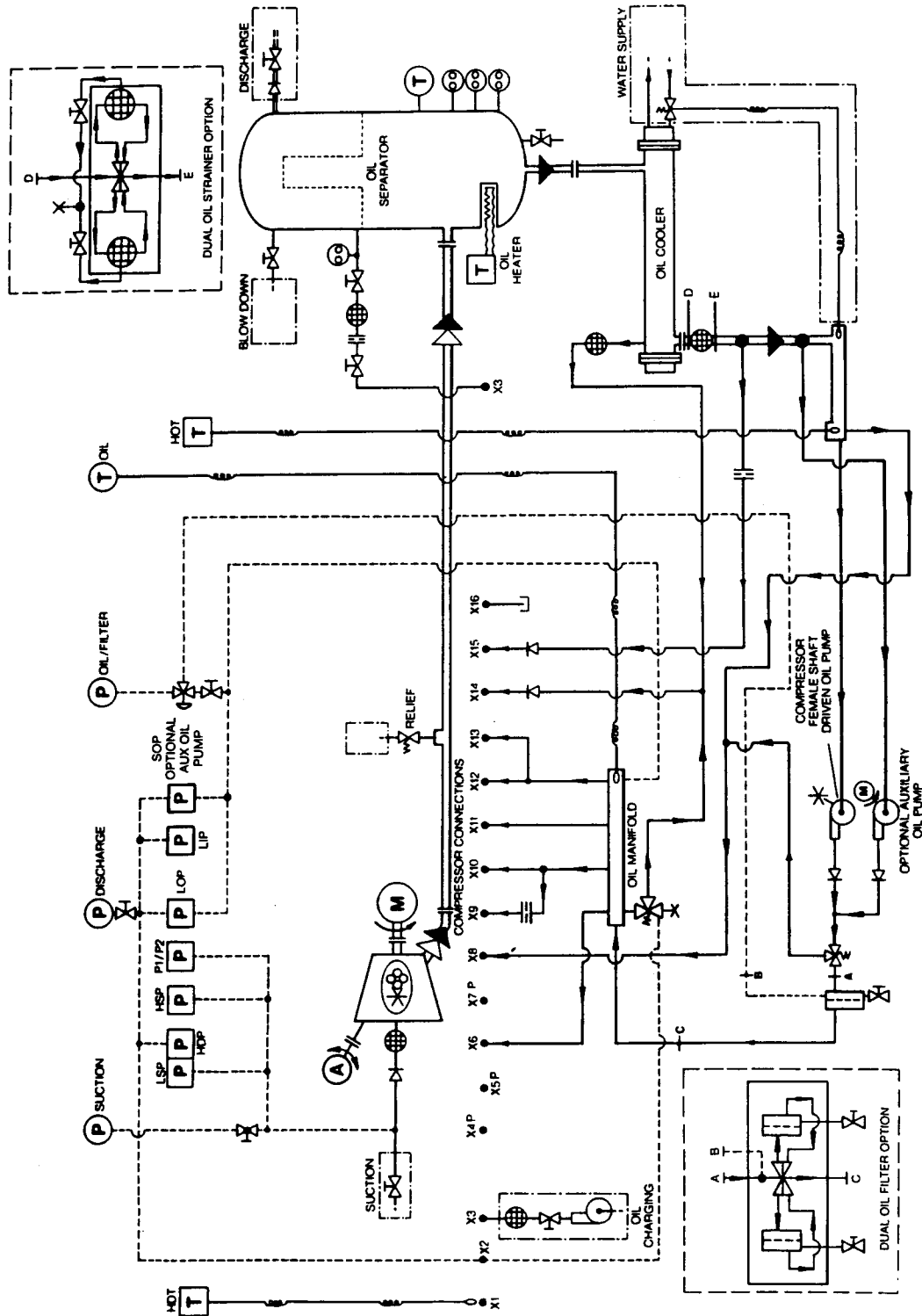

Section 2 DESCRIPTION

Figure 2-5E High Stage Water-Cooled Piping Schematic (C25S, C25M and C25L) for Compressor Units Built after 9-1-82 with 6XXXX-5XX Series Part Numbers

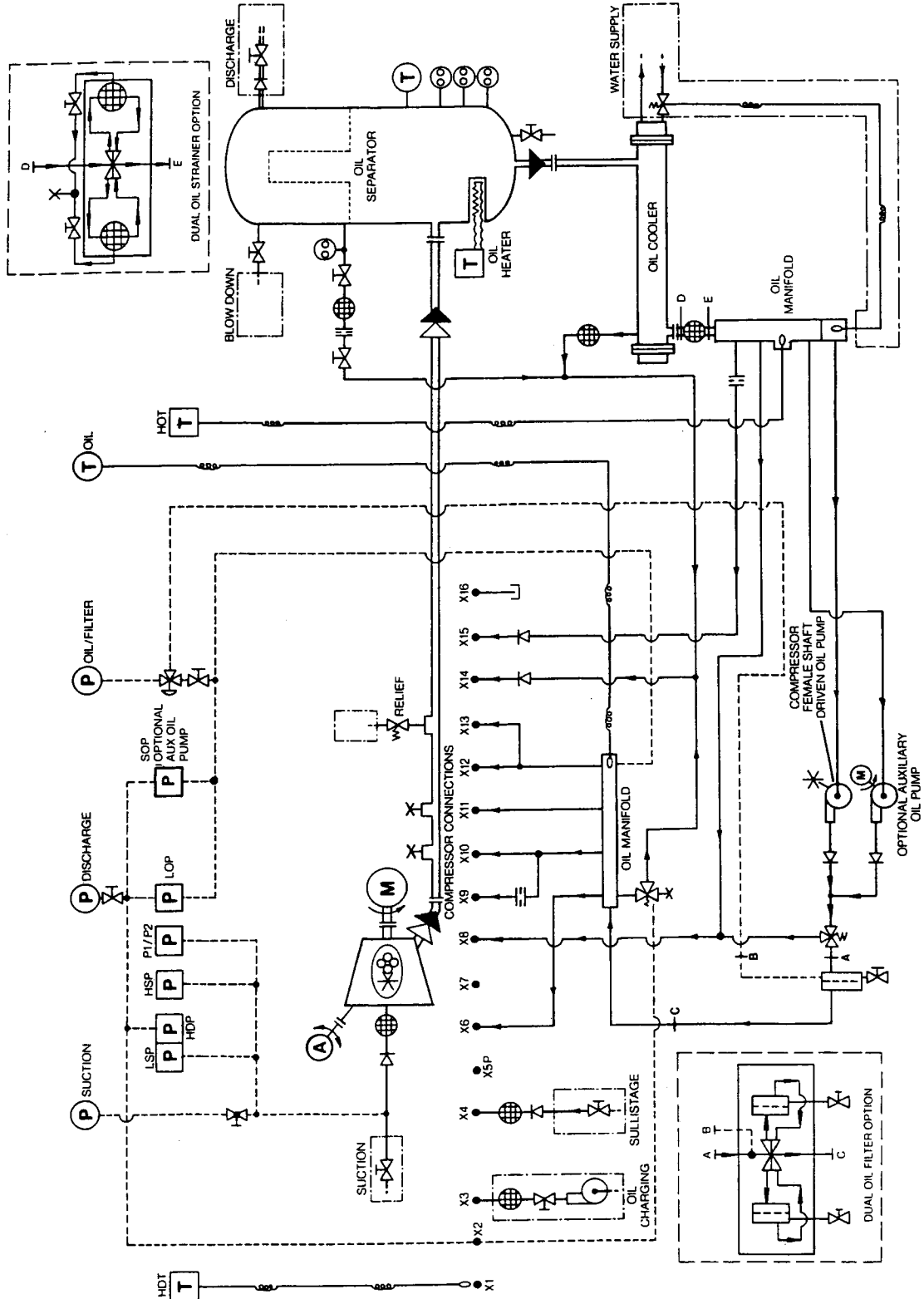

Section 2 DESCRIPTION

Figure 2-5F Booster Water-Cooled Piping Schematic (C25S, C25M and C25L) for Compressor Units Built after 9-1-82 with 6XXXX-5XX Series Part Numbers

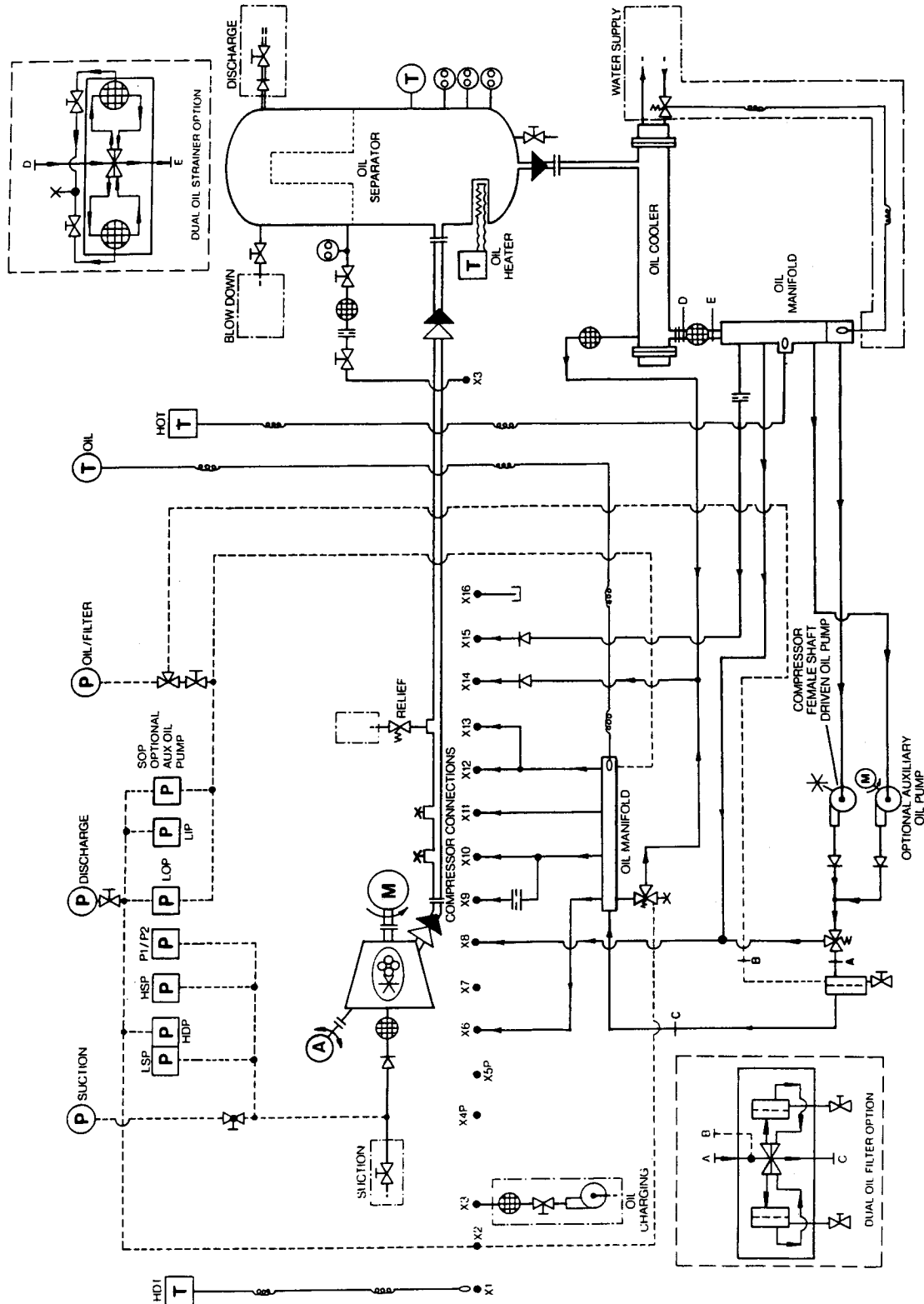

Section 2 DESCRIPTION

Figure 2-6A High Stage Liquid Injection Piping Schematic (except C25S and C25L) for Compressor Units Built Before 1-1-80

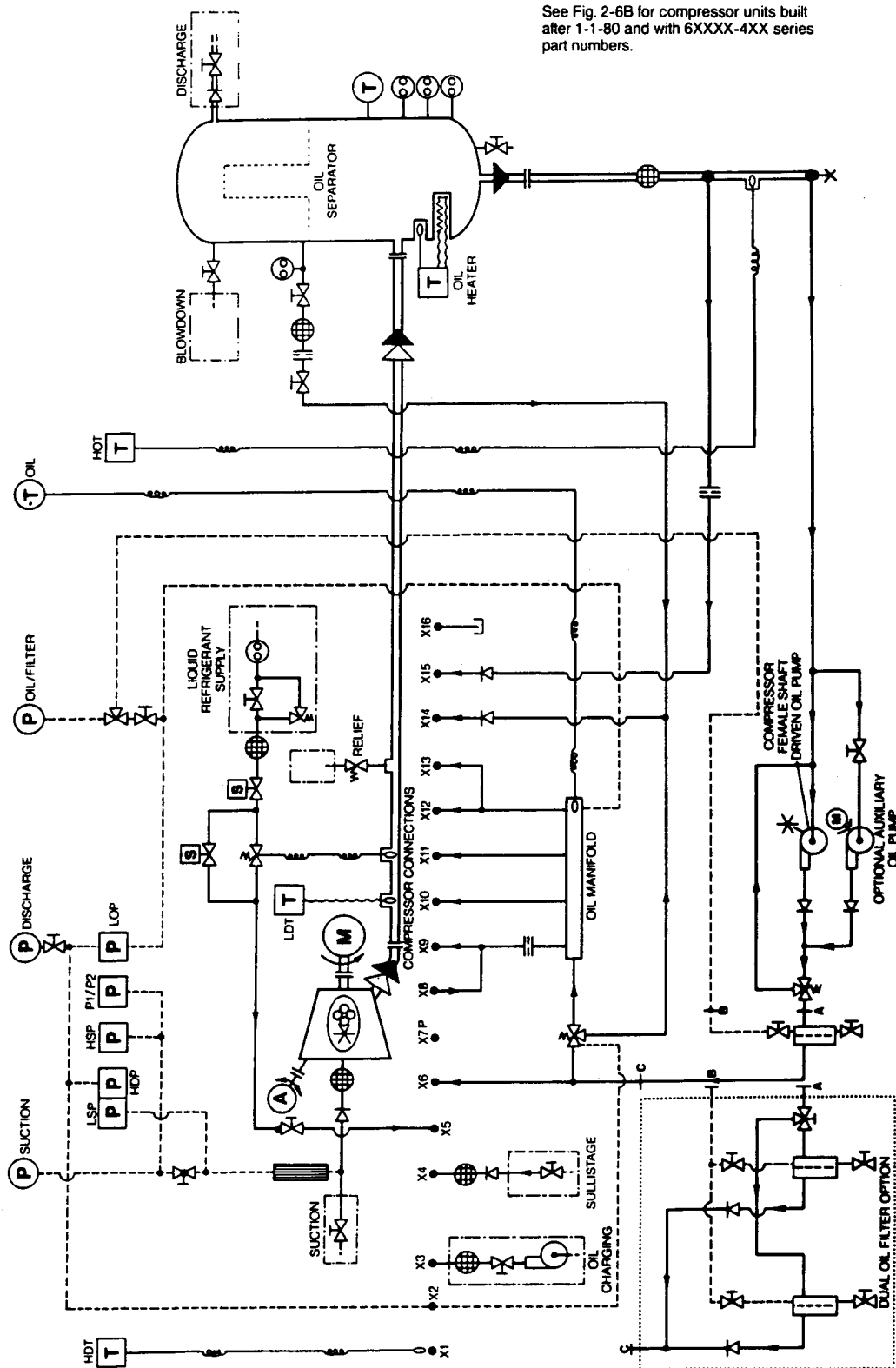

Section 2 DESCRIPTION

Figure 2-6B High Stage Liquid Injection Piping Schematic (except C25S and C25L) with 6XXXX-4XX Series Part Numbers

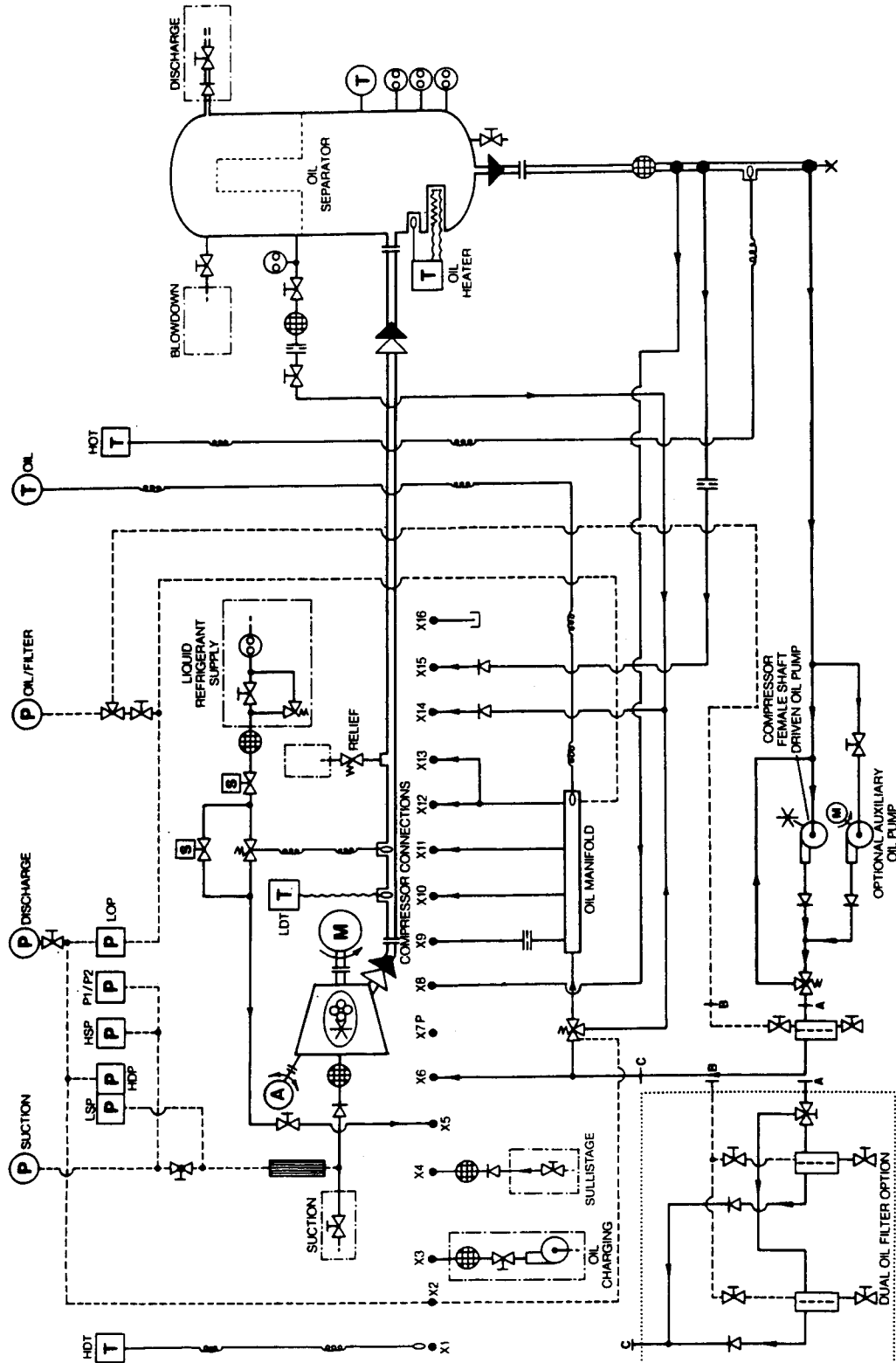

Section 2 DESCRIPTION

Figure 2-6C High Stage Liquid Injection Piping Schematic (C16 and C20) for Compressor Units with 6XXX-5XX Series Part Numbers

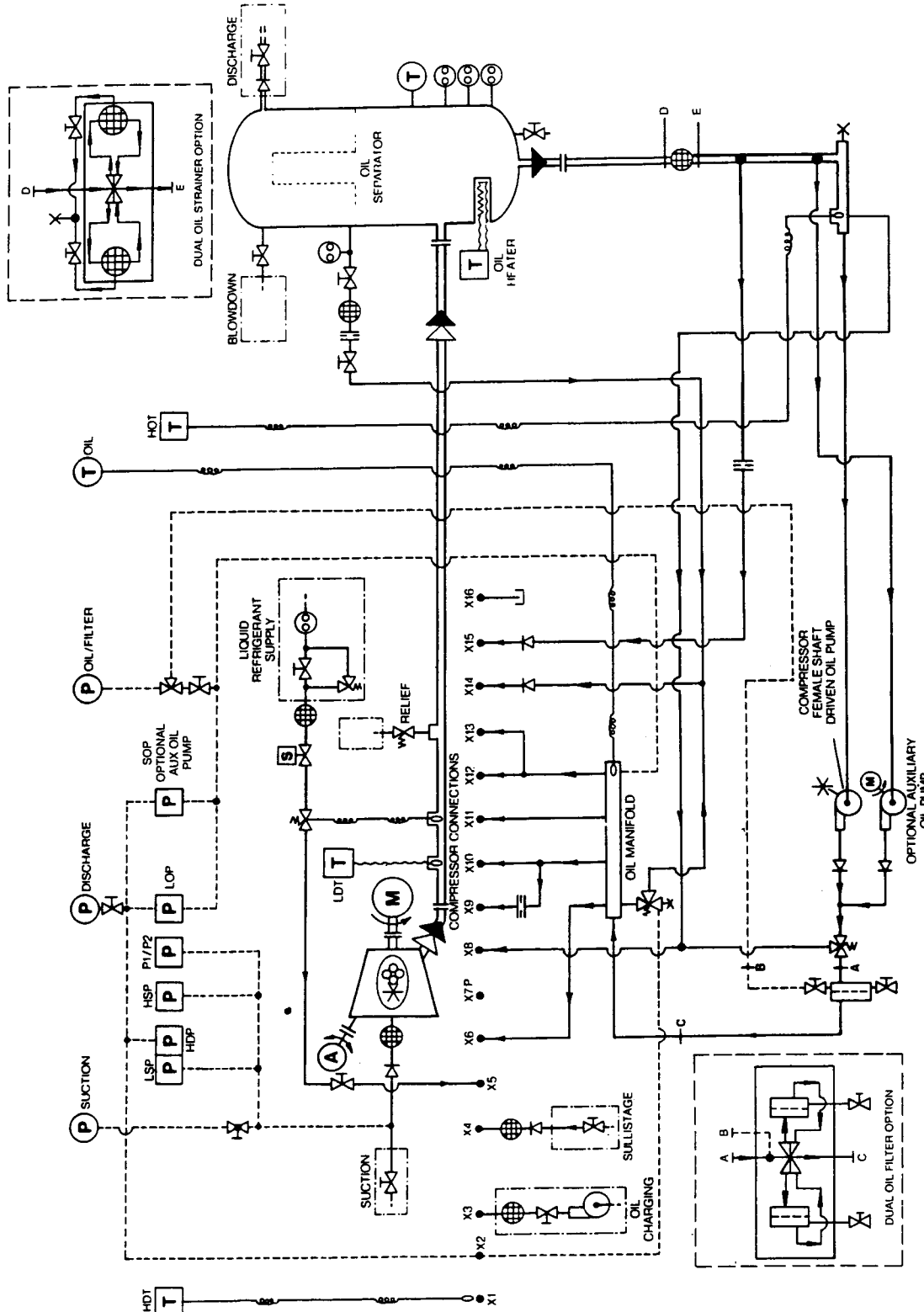

Section 2 DESCRIPTION

Figure 2-6D Booster Liquid Injection Piping Schematic (C16 and C20) for Compressor Units with 6XXX-5XX Series Part Numbers

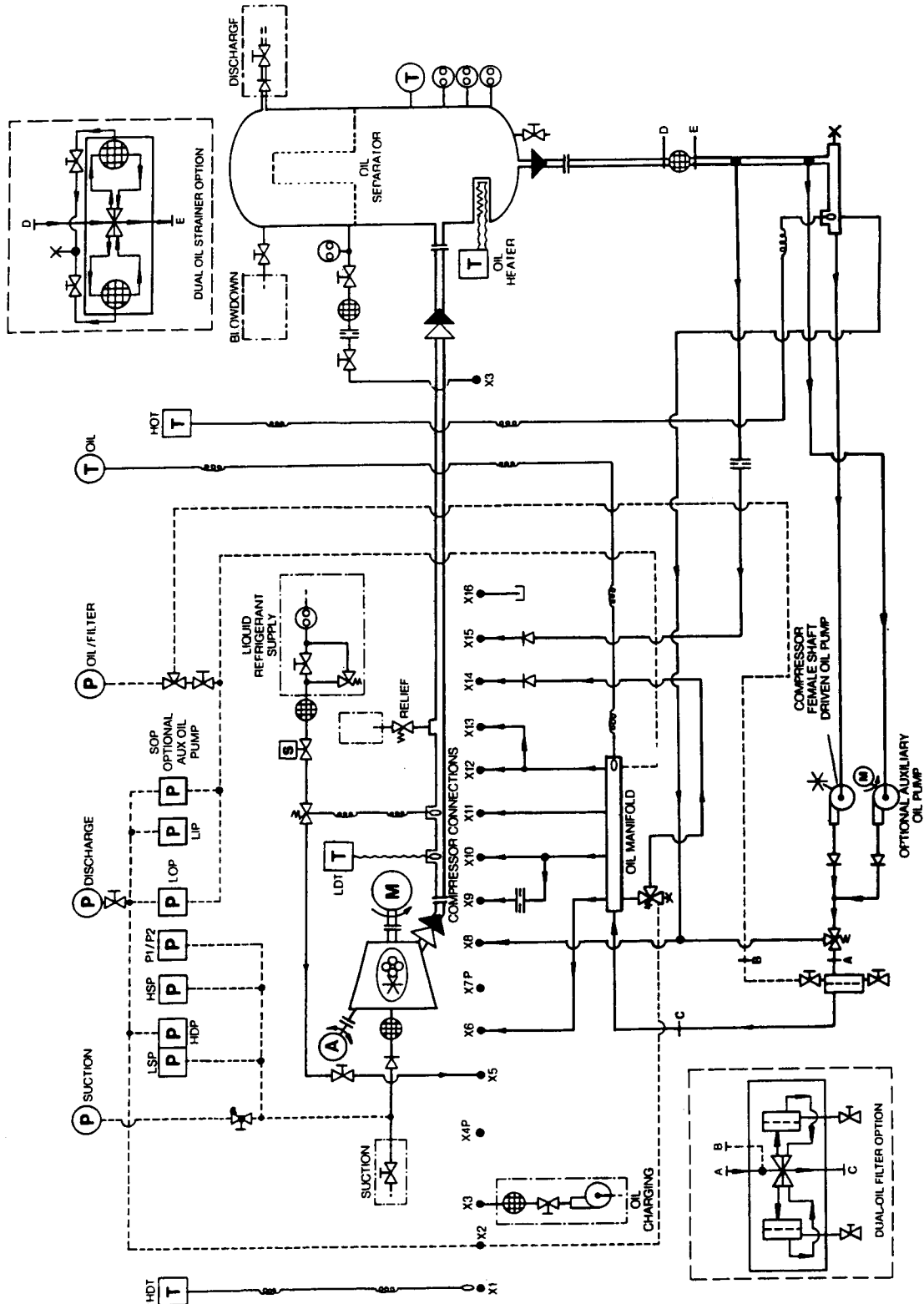

Section 2 DESCRIPTION

Figure 2-6E High Stage Liquid Injection Piping Schematic (C25S and C25L) for Compressor Units Built Before 1-1-80

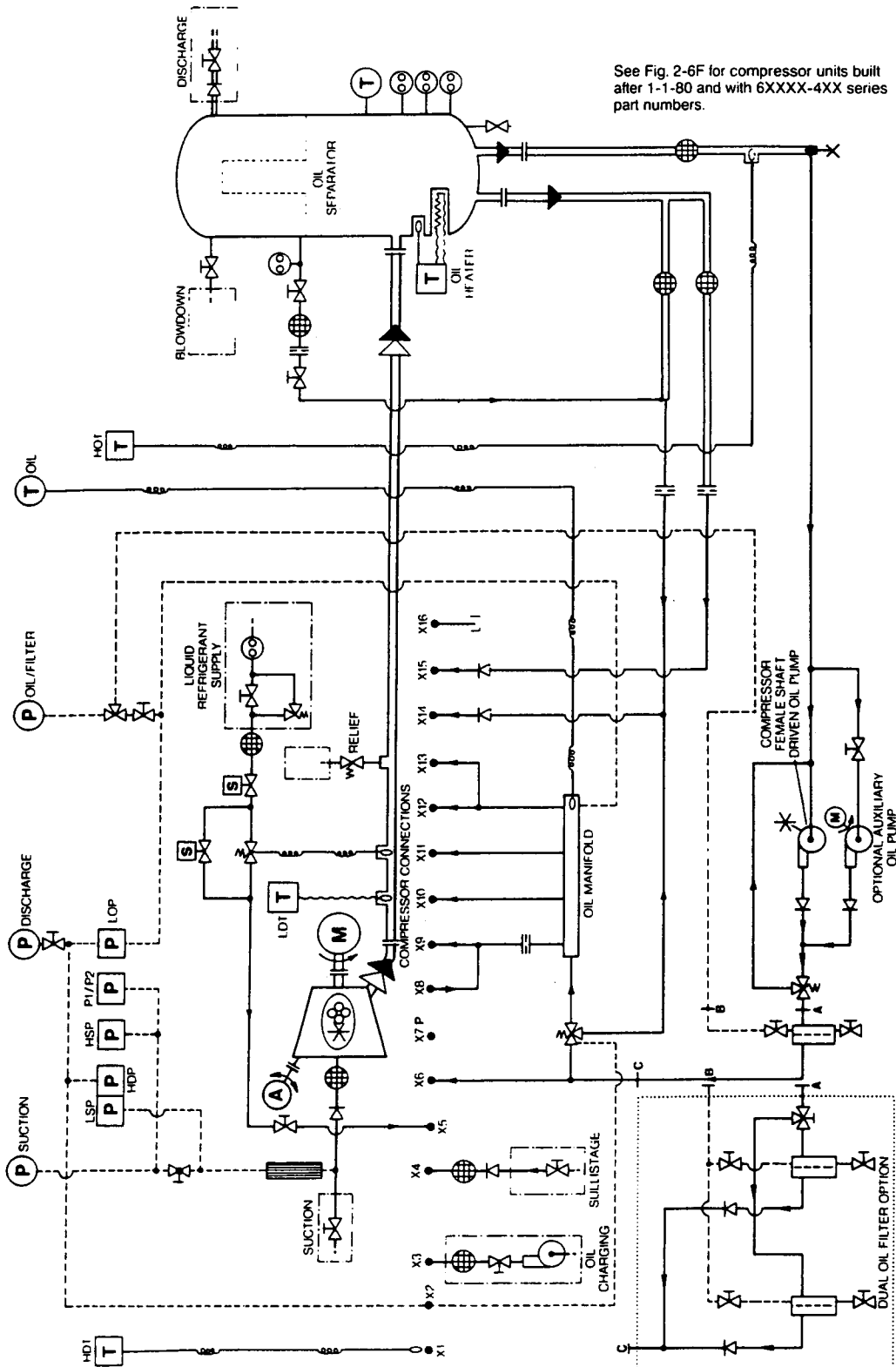

Section 2 DESCRIPTION

Figure 2-6F High Stage Liquid Injection Piping Schematic (C25S and C25L) with 6XXX-4XX Series Part Numbers for Compressors Built Between 1-1-80 and 9-1-82

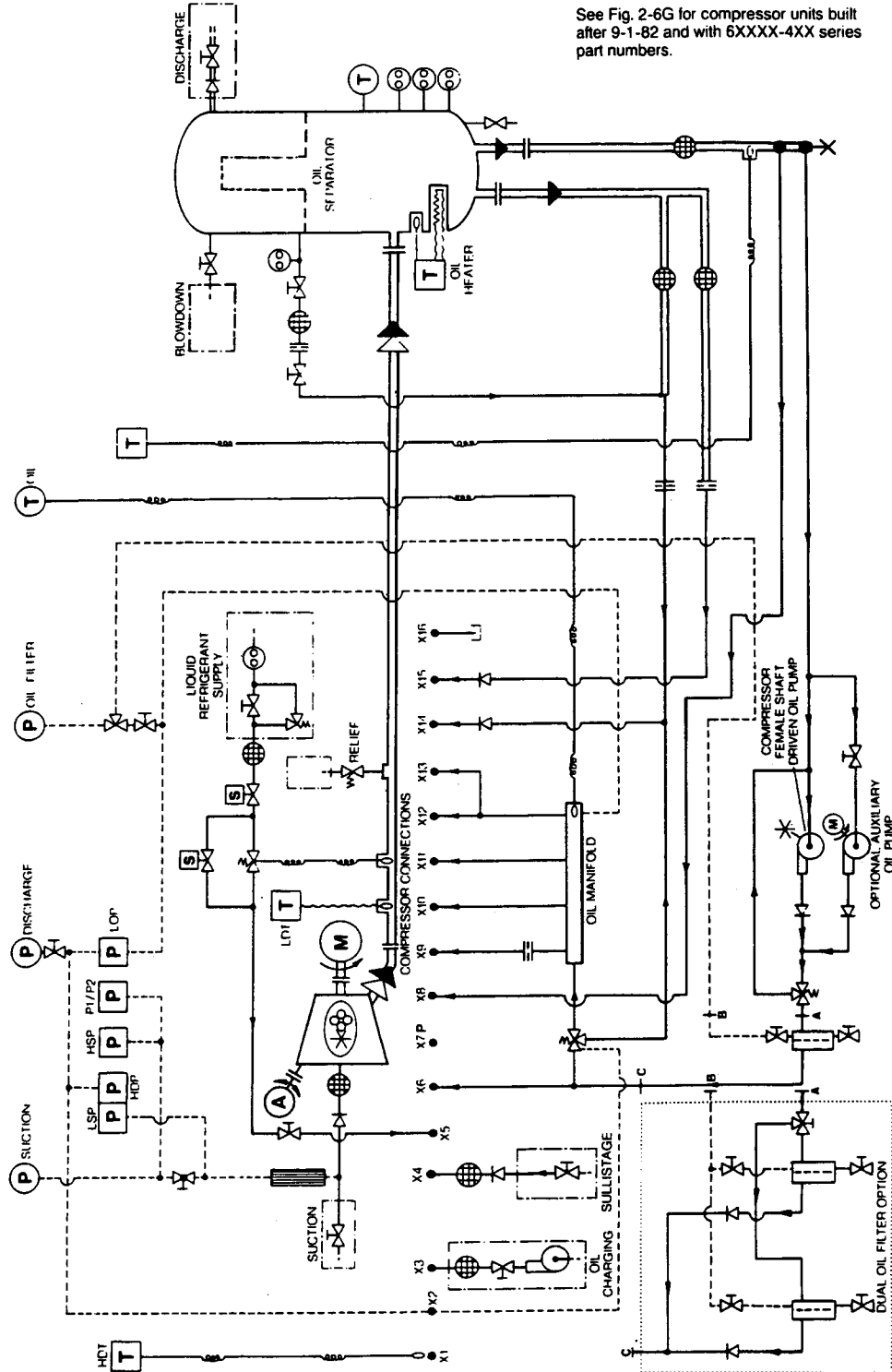

See Fig. 2-6G for compressor units built after 9-1-82 and with 6XXX-4XX series part numbers.

Section 2 DESCRIPTION

Figure 2-6G High Stage Liquid Injection Piping Schematic (C25S, C25M and C25L) for Compressor Units Built After 9-1-82 with 6XXX-4XX Series Part Numbers

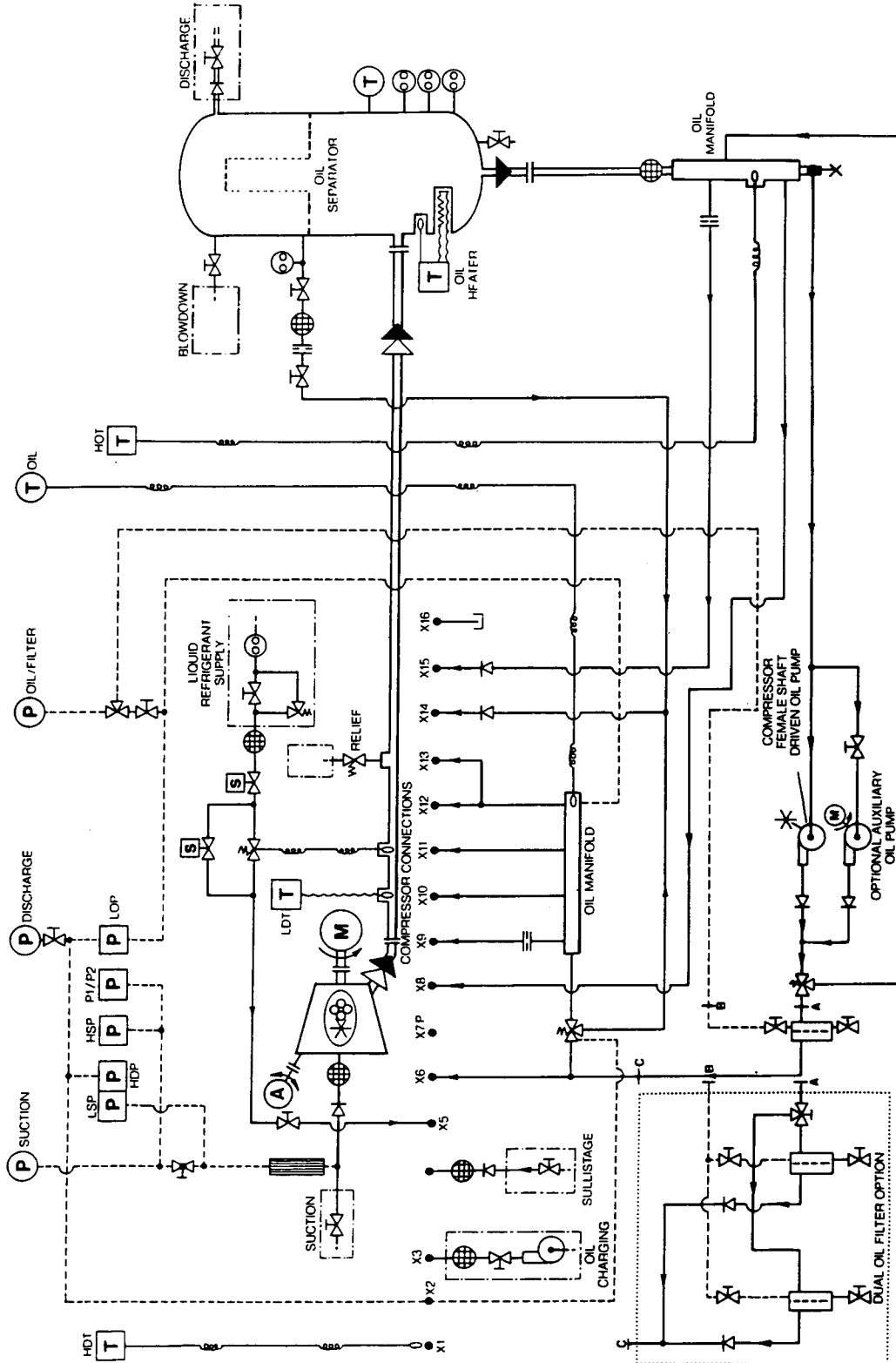

Section 2 DESCRIPTION

Figure 2-6H High Stage Liquid Injection Piping Schematic (C25S, C25M and C25L) with 6XXXX-5XX Series Part Numbers

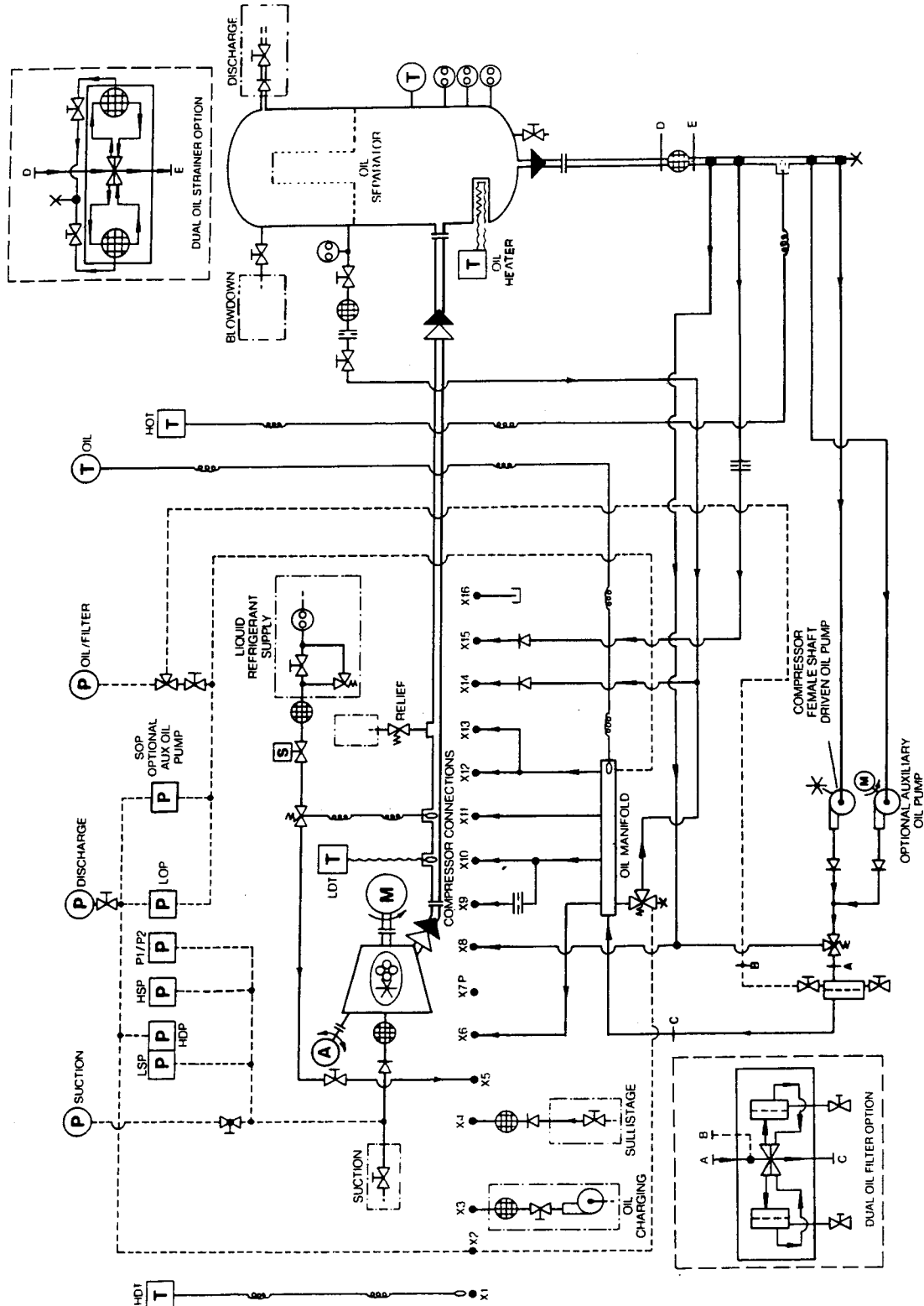

Section 2 DESCRIPTION

Figure 2-6J Booster Liquid Injection Piping Schematic (C25S, C25M and C25L) with 6XXXX-5XX Series Part Numbers

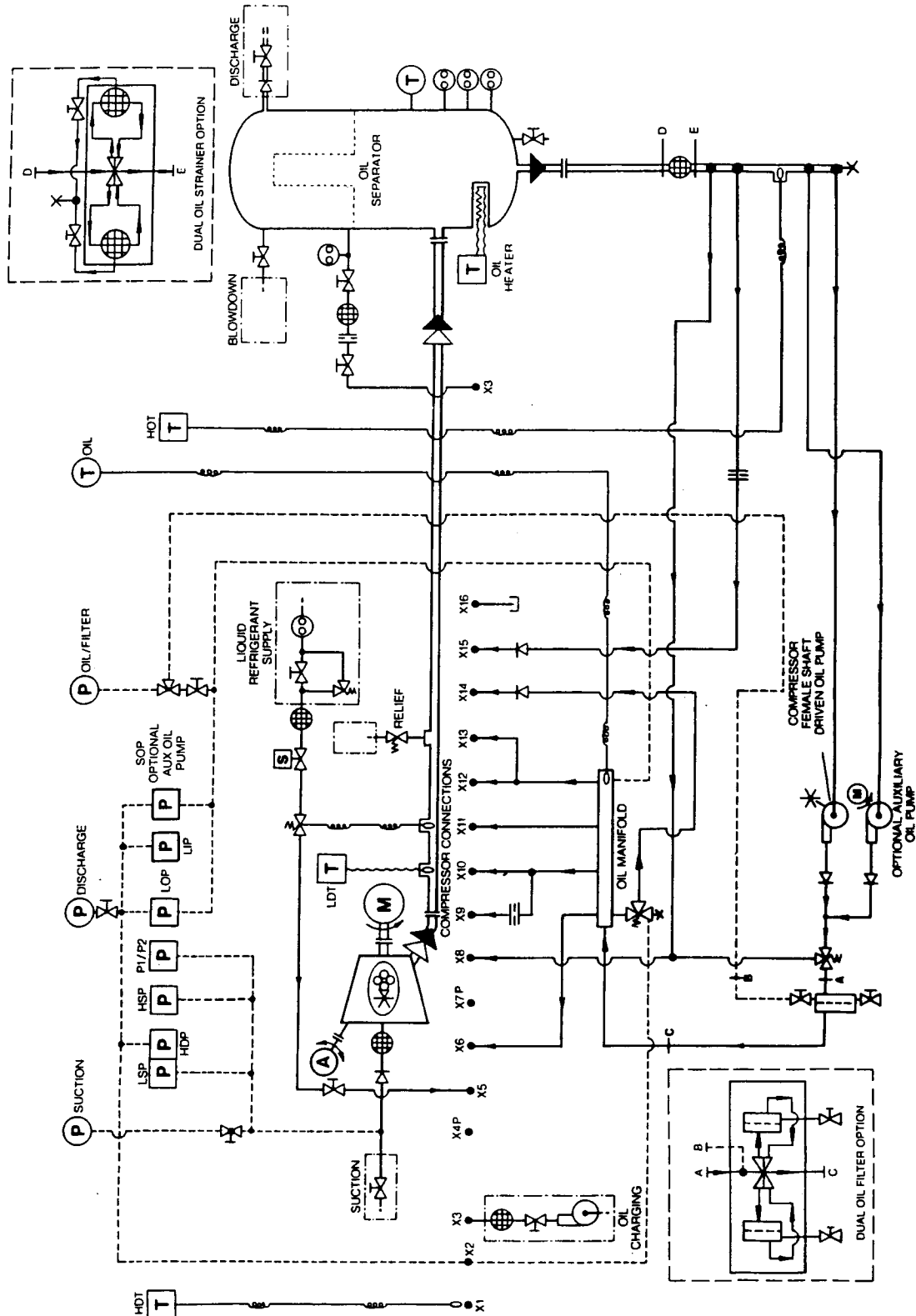

Section 2 DESCRIPTION

Figure 2-7A High Stage Thermosiphon Piping Schematic (C16 and C20) for Compressor Units with 6XXX-5XX Series Part Numbers

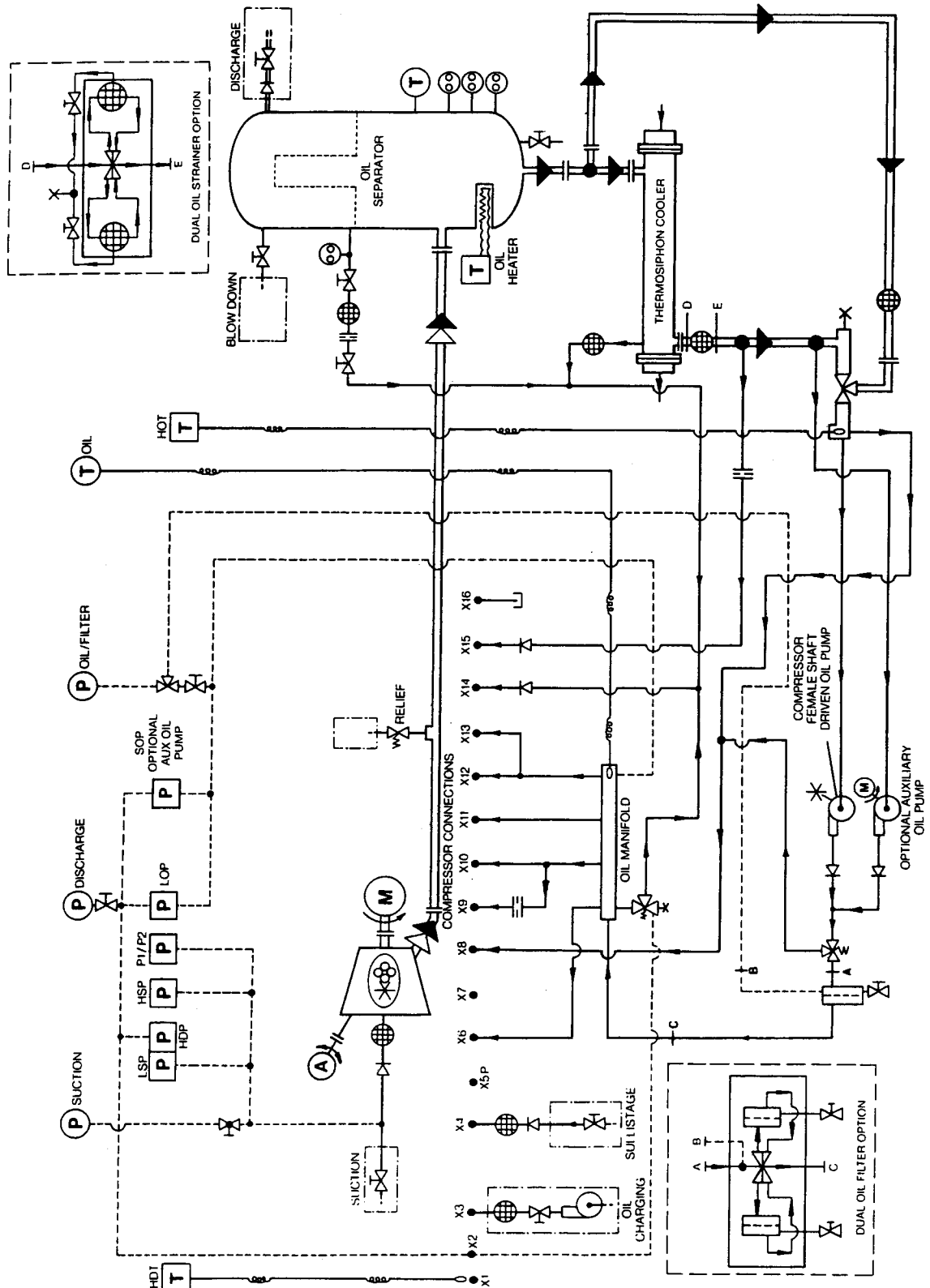

Section 2 DESCRIPTION

Figure 2-7B Booster Thermosiphon Piping Schematic (C16 and C20) for Compressor Units with 6XXX-5XX Series Part Numbers

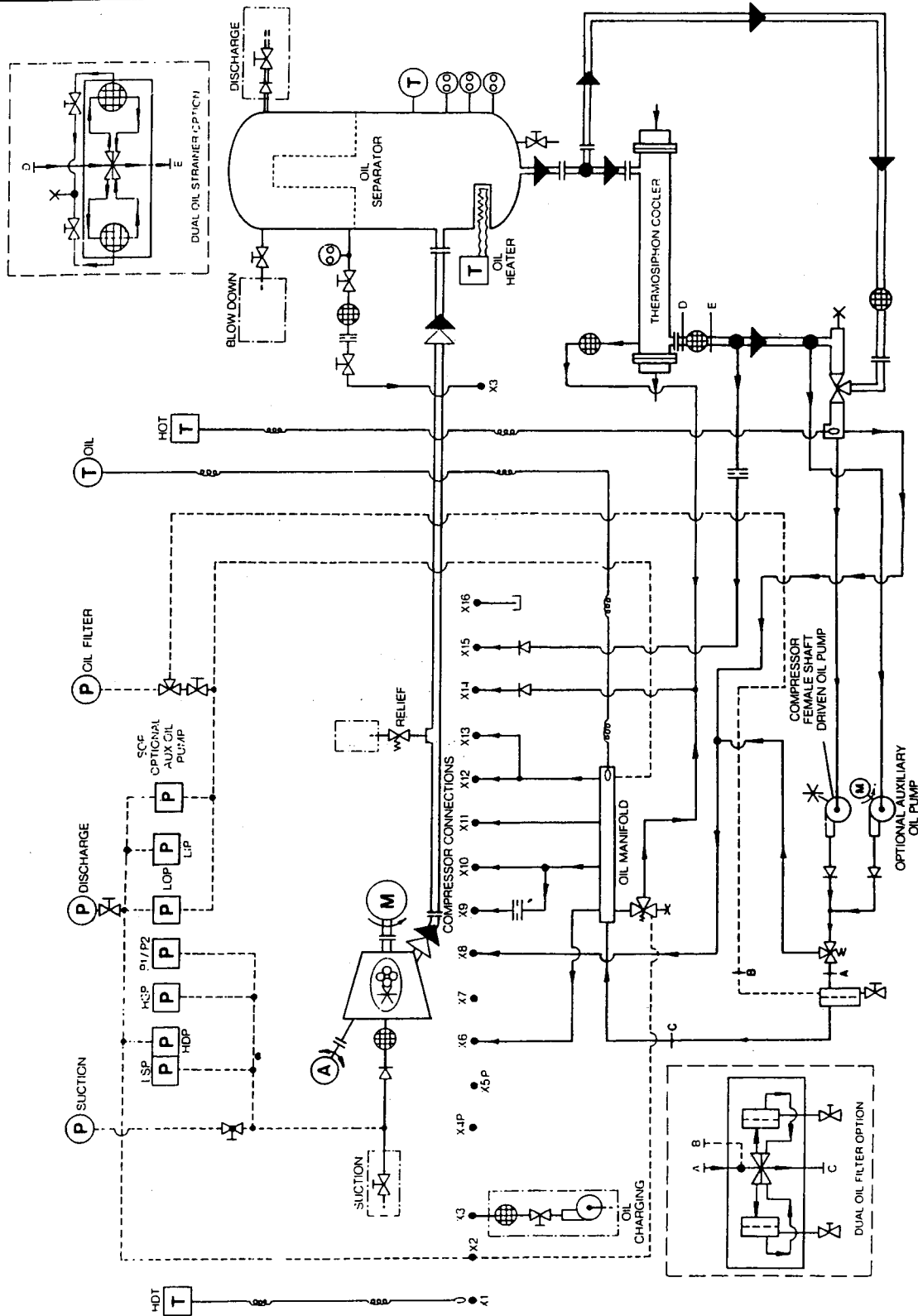

Section 2 DESCRIPTION

Figure 2-7C High Stage Thermosiphon Piping Schematic (C25S, C25M and C25L)
for Compressor Units with 6XXX-5XX Series Part Numbers

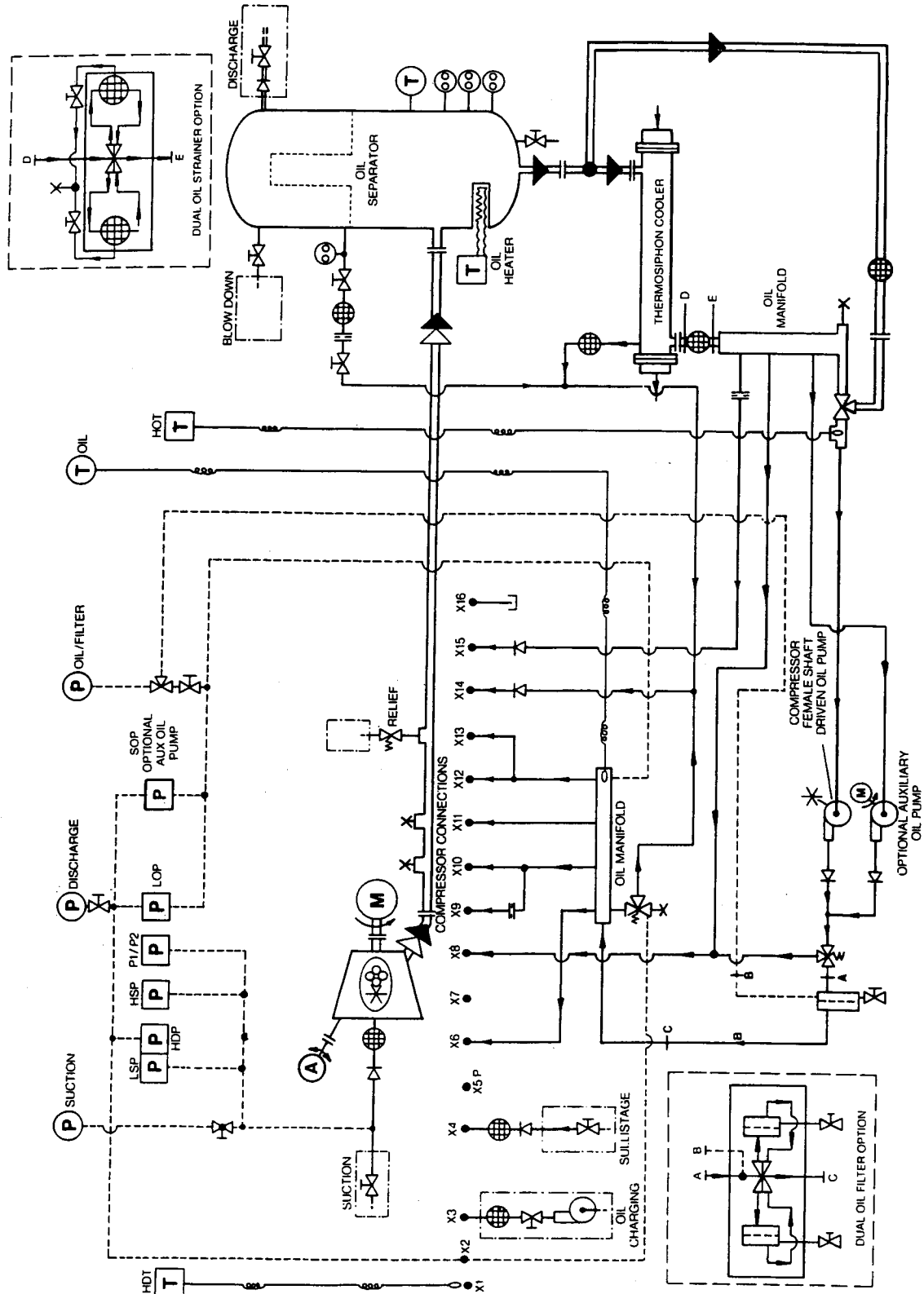

Section 2 DESCRIPTION

Figure 2-7D Booster Thermosiphon Piping Schematic (C25S, C25M and C25L)
for Compressor Units with 6XXX-5XX Series Part Numbers

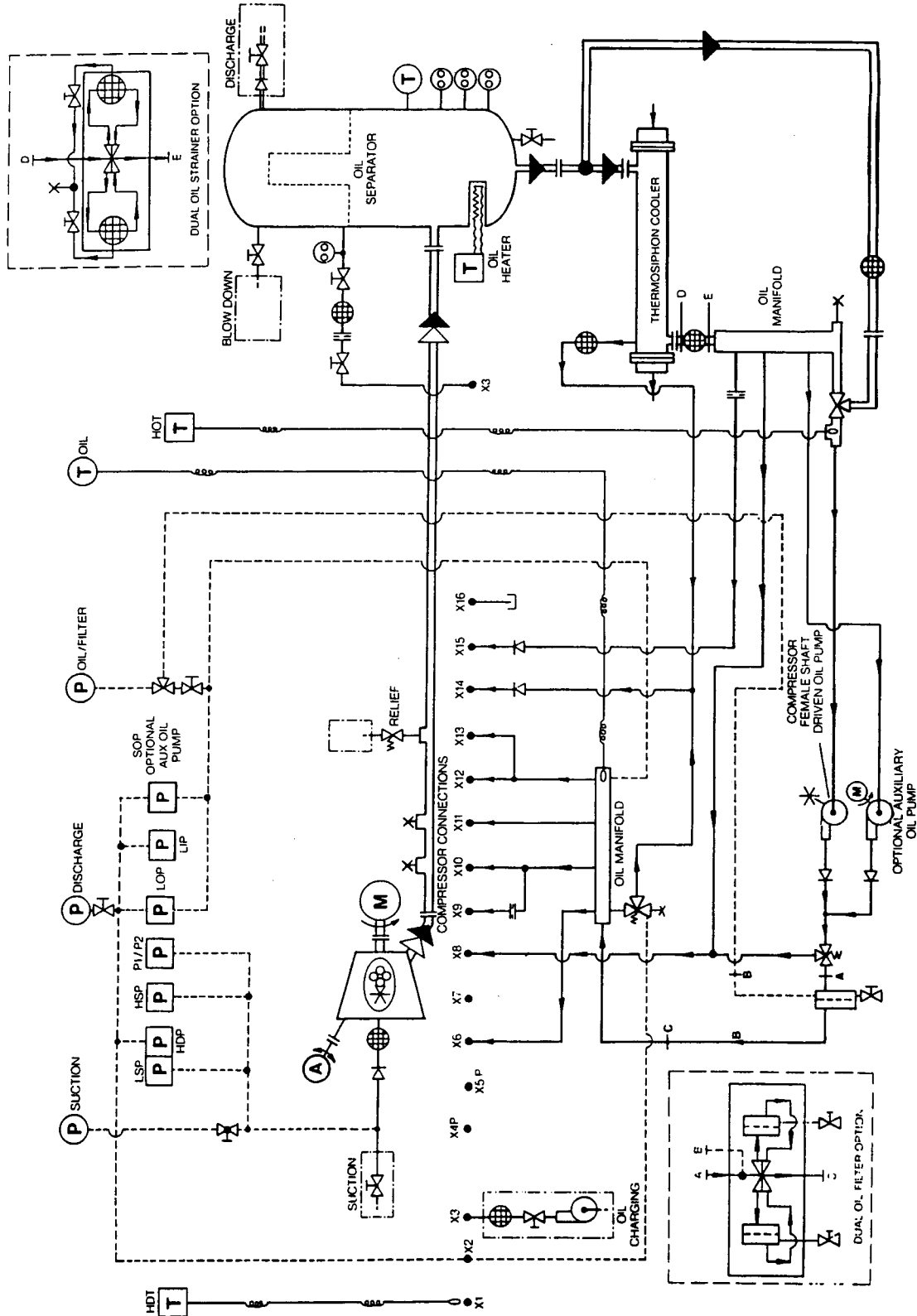

TABLE 1

TERMINOLOGY OF PRESSURE AND TEMPERATURE SWITCHES

First Letter: Function (high, low, system etc.)
 Second Letter: Sensed Point (suction, discharge, oil etc.)
 Third Letter: Pressure, Temperature

LSP	Low Suction Pressure Shutdown (Manual/Reset)
HSP	High Suction Pressure Start/Stop (Auto/Reset)
HDP	High Discharge Pressure Shutdown (Manual/Reset)
HDP/LSP	High Discharge Pressure Shutdown or Low Suction Pressure Shutdown (Manual/Reset)
LOP	Low Oil Pressure Shutdown (Manual/Reset)
SOP	Start-up Oil Pressure – Enables Compressor Start (Auto/Reset)
LDT	Low Discharge Temperature (Auto/Reset)
HOT	High Oil Temperature Shutdown (Manual/Reset)
HDT	High Discharge Temperature Shutdown (Manual/Reset)
LIP	Low Intermediate Pressure (Auto/Reset)
P1/P2	Capacity Control Pressure Switch (Auto/Reset)

2.6 THE ELECTRICAL CONTROL SYSTEM

The package is supplied with a complete electrical control system. All normal running, protective and capacity controls are included.

The control system is completely wired, tubed, and mounted to the package in a Nema 1 control cabinet. The controls operate on 115V, 1 phase, 60 Hz power supply of 500 VA capacity or 2.5 KVA if auxiliary oil pump is installed. See the standard wiring diagrams (Figures 2-8A thru 2-10C) for additional details and keys to the description below. These diagrams are only typical; see the wiring diagram for your compressor for specific details.

All Sullair Refrigeration wiring diagrams are drawn with relays de-energized and normal operating pressures and temperatures. The motor current transformer (CT) and the ampere relay have to be normally field wired and this is shown in dashed lines.

The terminology and graphics of the pressure switches and temperature switches are given in Tables 1 and 2.











The “Auto-Start”/“Manual-Reset” selector switch is a four function switch and the capacity control “Load/Auto/Unload” is a six function switch. In the wiring diagrams, the contacts of these multi-function pushbutton switches are shown with the switch in the left hand, center and right hand positions and the lower logic line shows the contact with the pushbutton depressed and the switch in the left hand, center and right hand positions. For example, to manually load the compressor, the capacity control selector switch should be turned to the “Load” position and the pushbutton depressed. When the pushbutton is released, the compressor stops loading.

The labeled wire numbers are shown on the wiring diagrams. The numbers on the far right hand side of the wiring diagrams refer to the line numbers where the contacts function. If the number is underlined, it refers to a normally closed contact.

Section 2

DESCRIPTION

TABLE 2
GRAPHICS OF PRESSURE AND TEMPERATURE SWITCHES

	N.O. (I)	No pressure applied or pressure lower than setpoint. Switch is reset (special case for HDP/LSP switch pressure higher than low setpoint and lower than high setpoint).
	N.C. (II)	
	N.O.	Pressure applied higher than setpoint. Switch is tripped (special case for HDP/LSP switch pressure higher than high setpoint or lower than low setpoint).
	N.C.	
	N.C.	Temperature lower than setpoint. Switch is reset.
	N.C.	Temperature higher than setpoint. Switch is tripped.
	N.O.	Some Switches have a common terminal
	N.C.	with a double contact.
	N.O.	
	N.C.	

(I) N.O. = Normally Open Contact
(II) N.C. = Normally Closed Contact

RUNNING CONTROLS

START SWITCH

The START pushbutton is a multi-function switch allowing the compressor to operate in manual or automatic starting modes and also serving as a protective circuit reset (1CR).

To start the compressor, the pushbutton is rotated to the "Auto/Start" position and pushed. The compressor may then start and stop in the automatic mode via the HSP switch. If manual operation is desired after the START button has been pushed, the pushbutton is rotated to the "Manual/Reset" position. In the Manual position, the compressor will load and unload as the "Load/Auto/Unload" switch requires, but start-up and shutdown must be manually initiated.

In "Auto/Start" position, the compressor will automatically start whenever the suction pressure rises above an adjustable high setpoint on the "Start/Stop" pressure switch (HSP).

The compressor can then load and unload as required by the load/auto/unload selector switch and will automatically shutdown whenever the suction pressure falls below the lower adjustable setpoint on the HSP switch. If the suction pressure rises again, above the higher setpoint, automatic restart will be initiated. Auto restart will not occur when the compressor shuts down for a protective function, power interruption, if the STOP button is pushed, if the anti-recycle timer is timing, or if the compressor is not at minimum position.

If the LOP switch was tripped or the power interrupted, then the START button must be rotated to the "Manual/Reset position". Depressing the button will then reset the LOP circuit.

After a LOP reset or any other protective switch shutdown, resetting the control system is accomplished by rotating the START button to the "Auto/Start" position and depressing the button. The compressor can then be started again as described above provided the particular shutdown device is reset.

STOP BUTTON

The STOP button is a red pushbutton which will shut down the compressor in any mode of operation when pushed. A manual start will be required.

HIGH SUCTION PRESSURE START/STOP SWITCH (HSP)

The dual setpoint high suction pressure switch (HSP) allows automatic starting and stopping of the compressor at set cut-in and cut-out suction pressures. The HSP is wired such that the protective circuit and the protective relay, 1CR, remain energized during HSP cut-out.

CAPACITY CONTROL SWITCH (P1/P2)

The dual setpoint P1/P2 pressure switch controls automatic loading and unloading when the load/auto/unload selector switch is in the auto mode. As the suction pressure rises above the high pressure setpoint, the switch calls for the compressor to load. As the suction pressure drops below the low pressure setpoint, the switch calls for the compressor to unload. For suction pres-

Section 2 DESCRIPTION

Figure 2-8A Water/Liquid-Cooled High Stage Unit with DC Electric Valve Actuator Built Before 1-11-77 Wiring Diagram

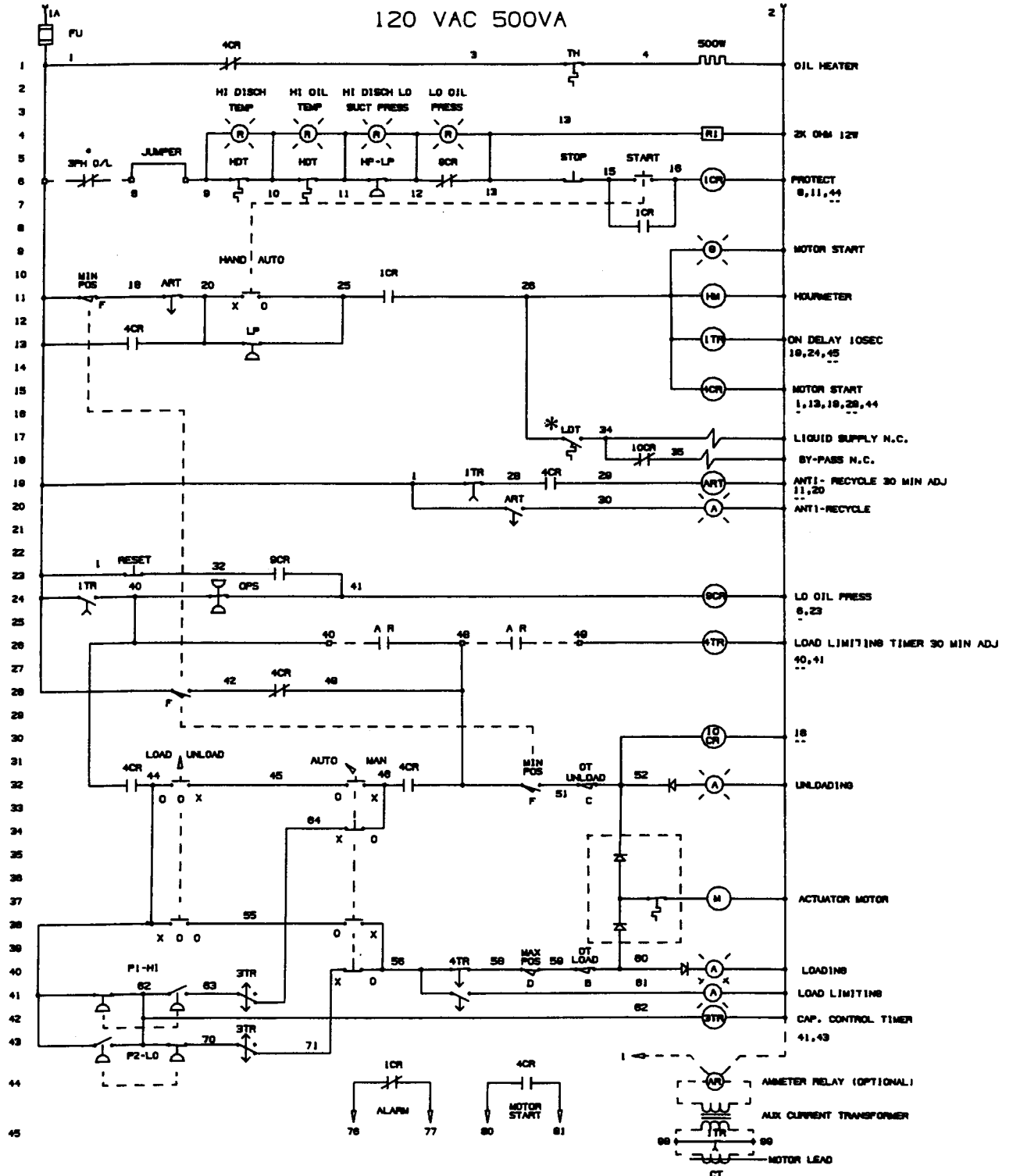

* Optional Liquid Injection Cooling

Section 2 DESCRIPTION

Figure 2-8C Liquid Injection High Stage Unit with DC Electric Valve Actuator Built Before 1-7-85
Wiring Diagram

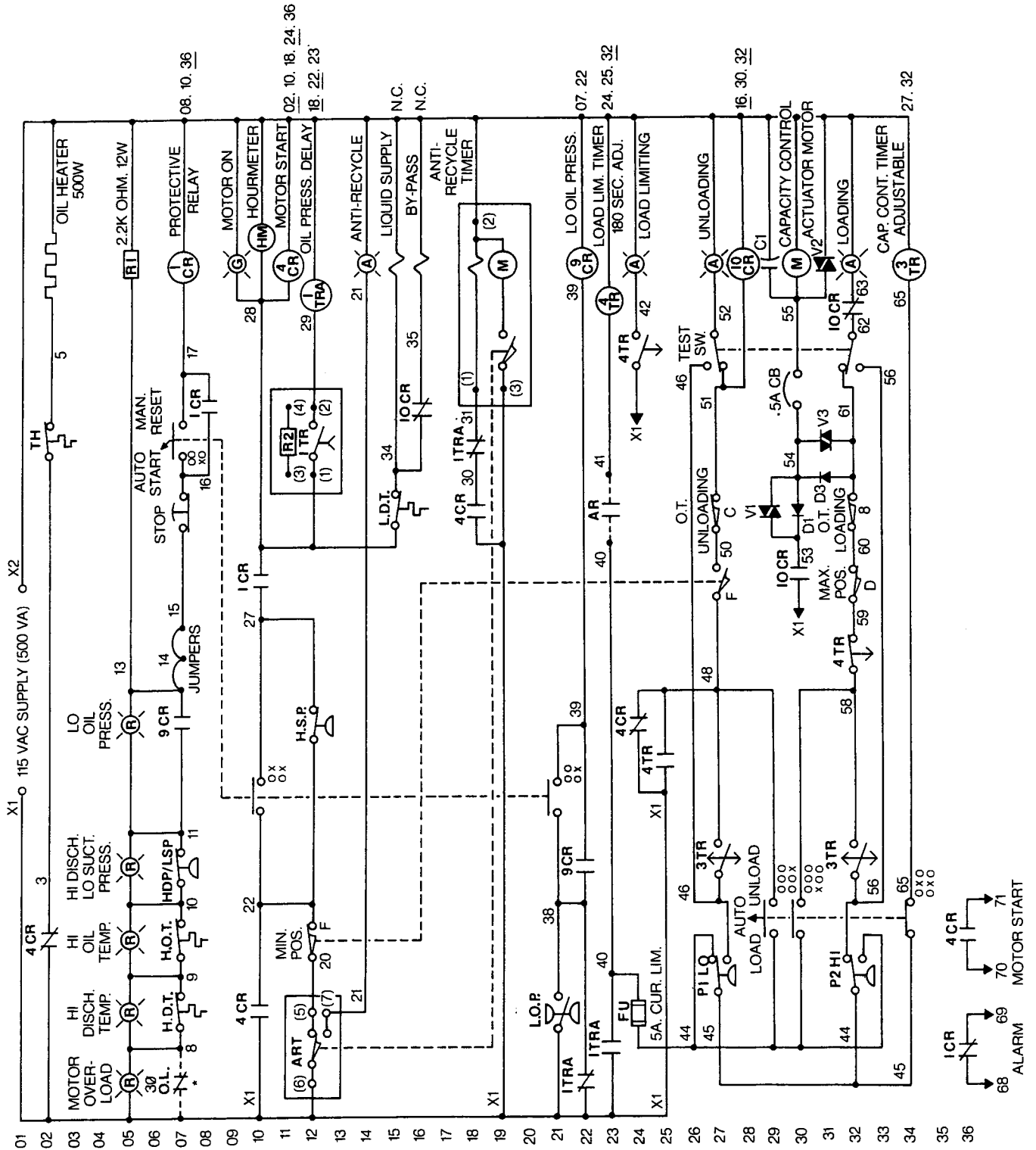

Section 2 DESCRIPTION

Figure 2-9A Water and Thermosiphon-Cooled High Stage Unit with AC Electric Valve Actuator Built Between 1-7-85 and 4-6-87 Wiring Diagram

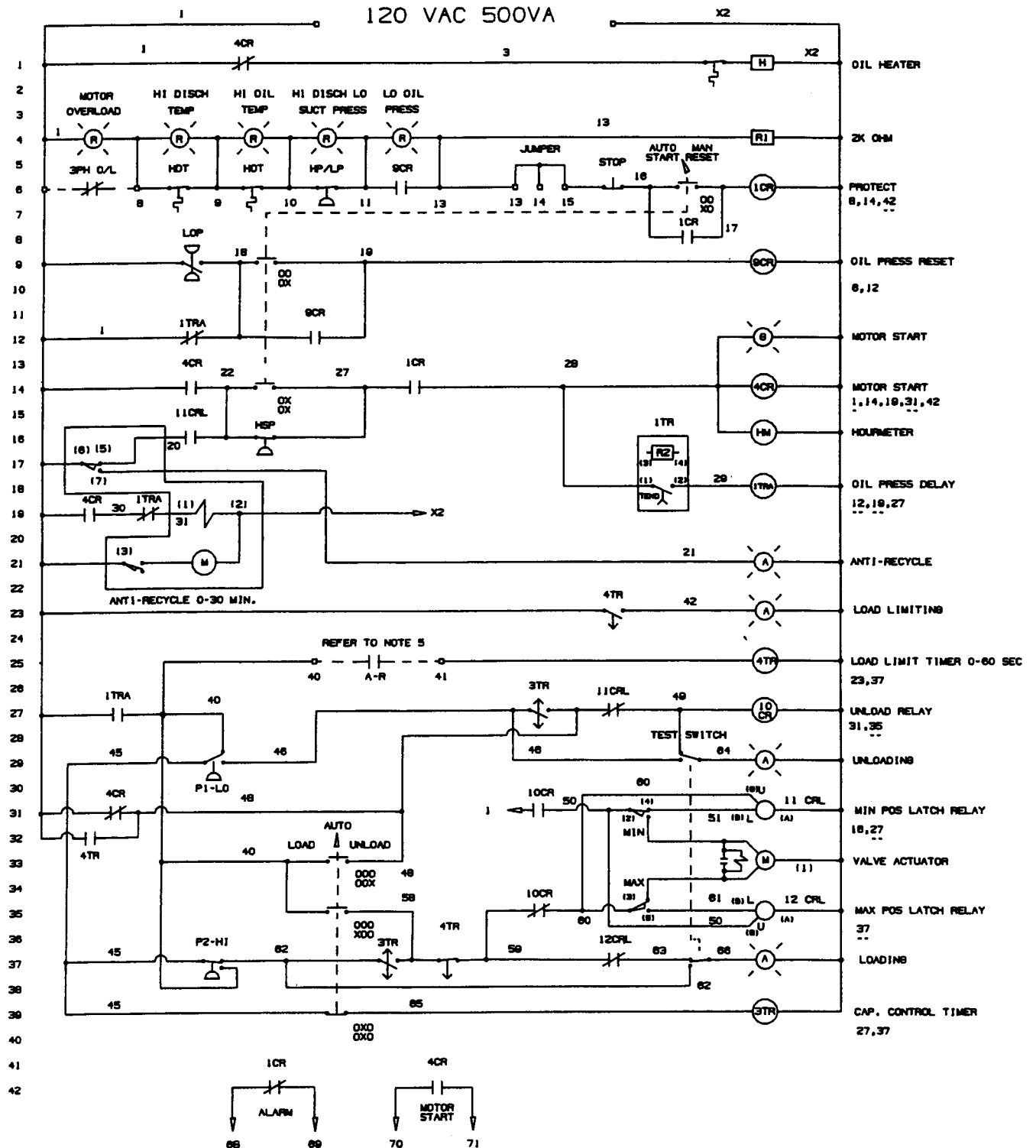

Section 2 DESCRIPTION

Figure 2-9D Liquid Injection Booster Unit with AC Electric Valve Actuator Built Between 1-7-85 and 4-6-87 Wiring Diagram

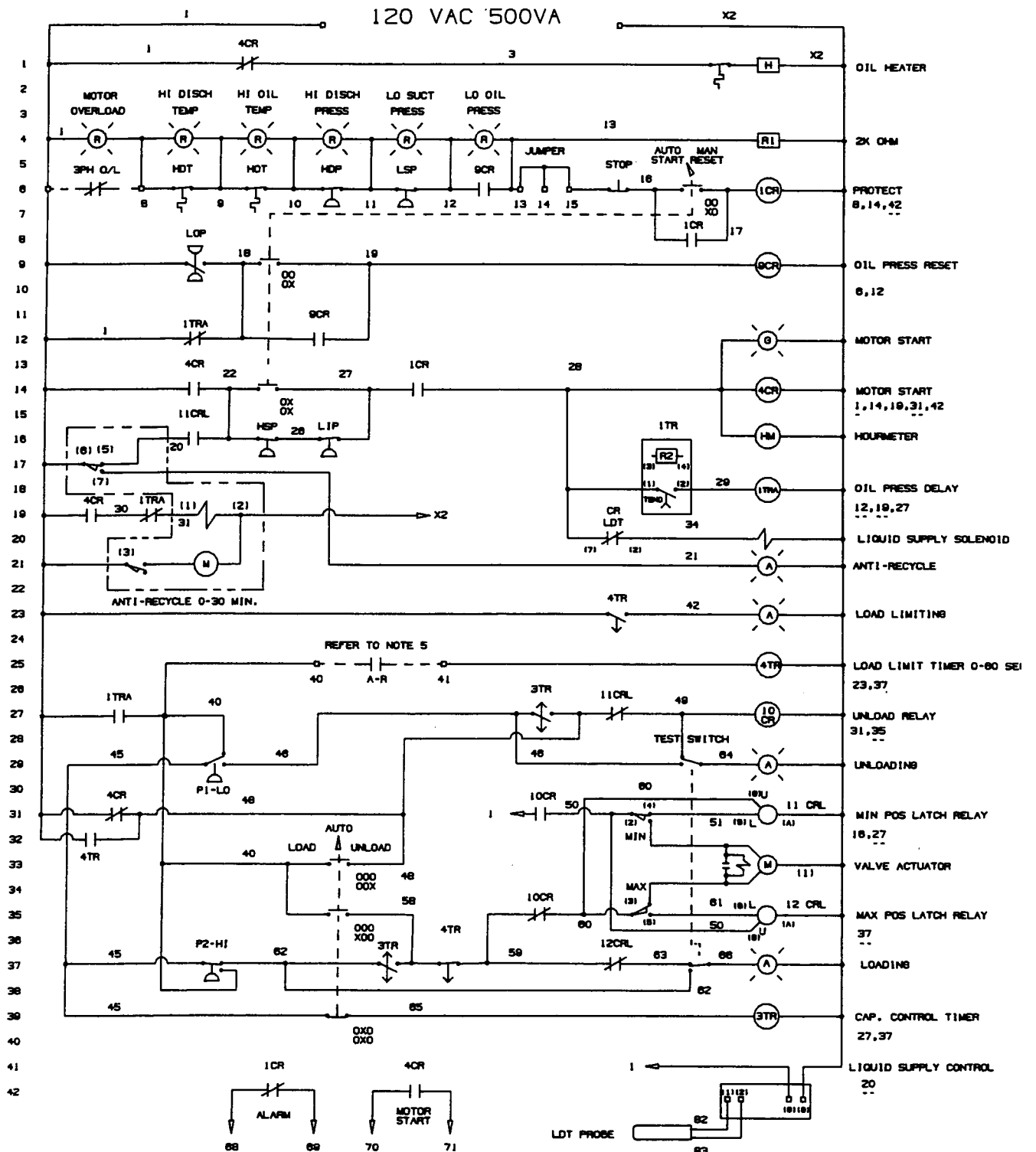

Section 2 DESCRIPTION

Figure 2-10 Water and Thermosiphon High Stage Unit with AC Electric Valve Actuator
Built After 4-6-87 Wiring Diagram

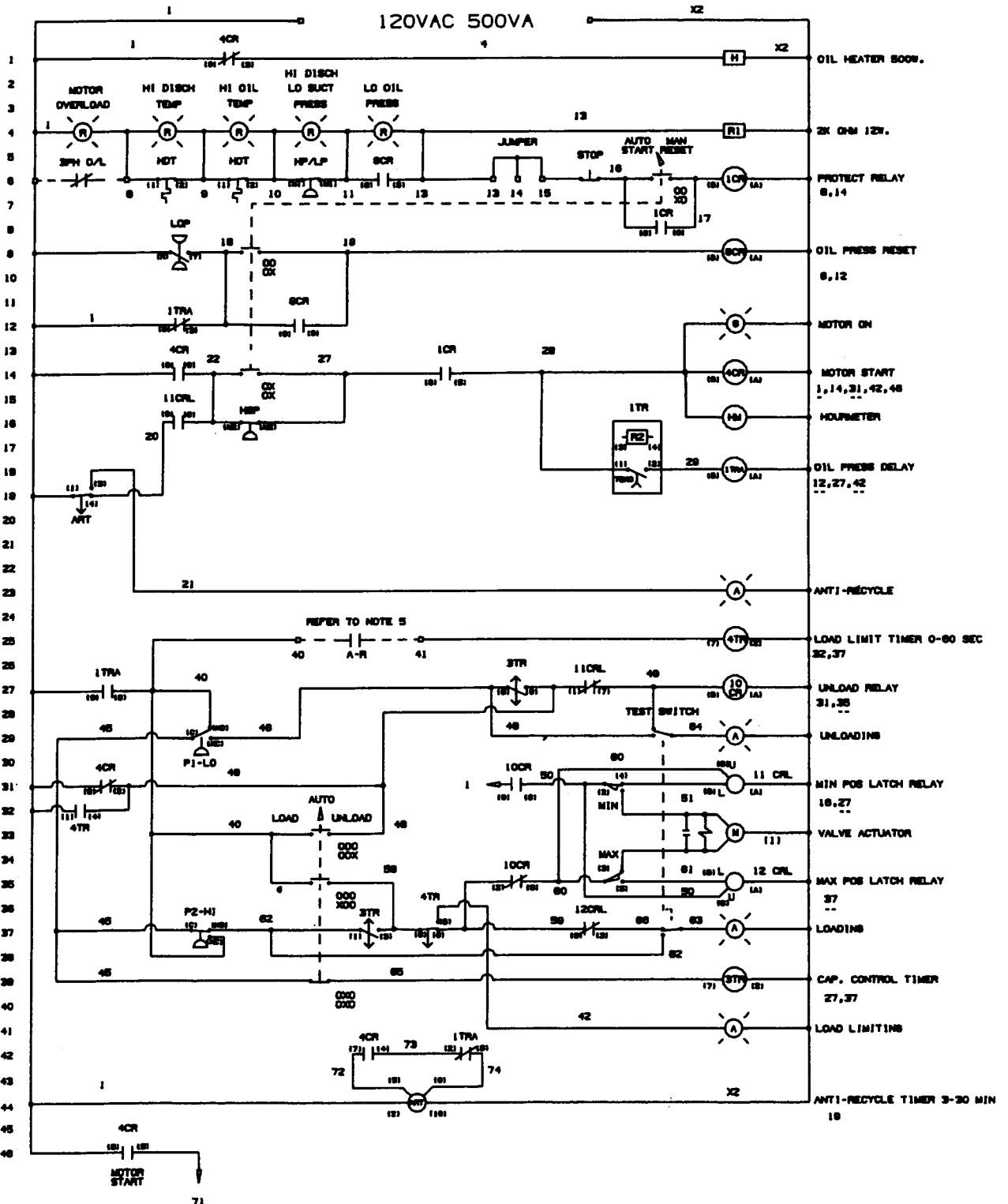

Section 2 DESCRIPTION

Figure 2-10B Water and Thermosiphon Booster Unit with AC Electric Valve Actuator Built After 4-6-87 Wiring Diagram

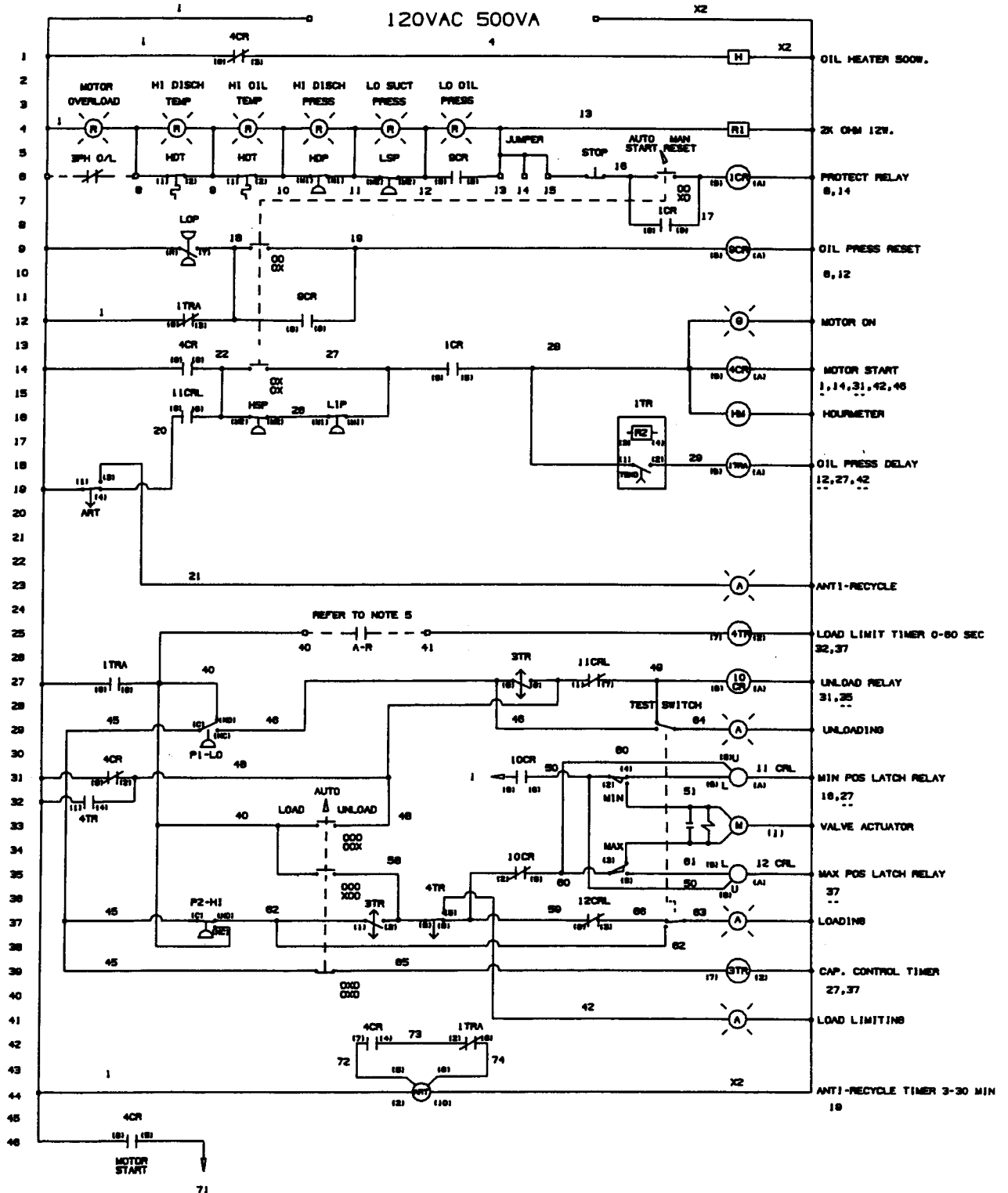

Section 2 DESCRIPTION

Figure 2-10C Liquid Injection Booster Unit with AC Electric Valve Actuator Built After 4-6-87
Wiring Diagram

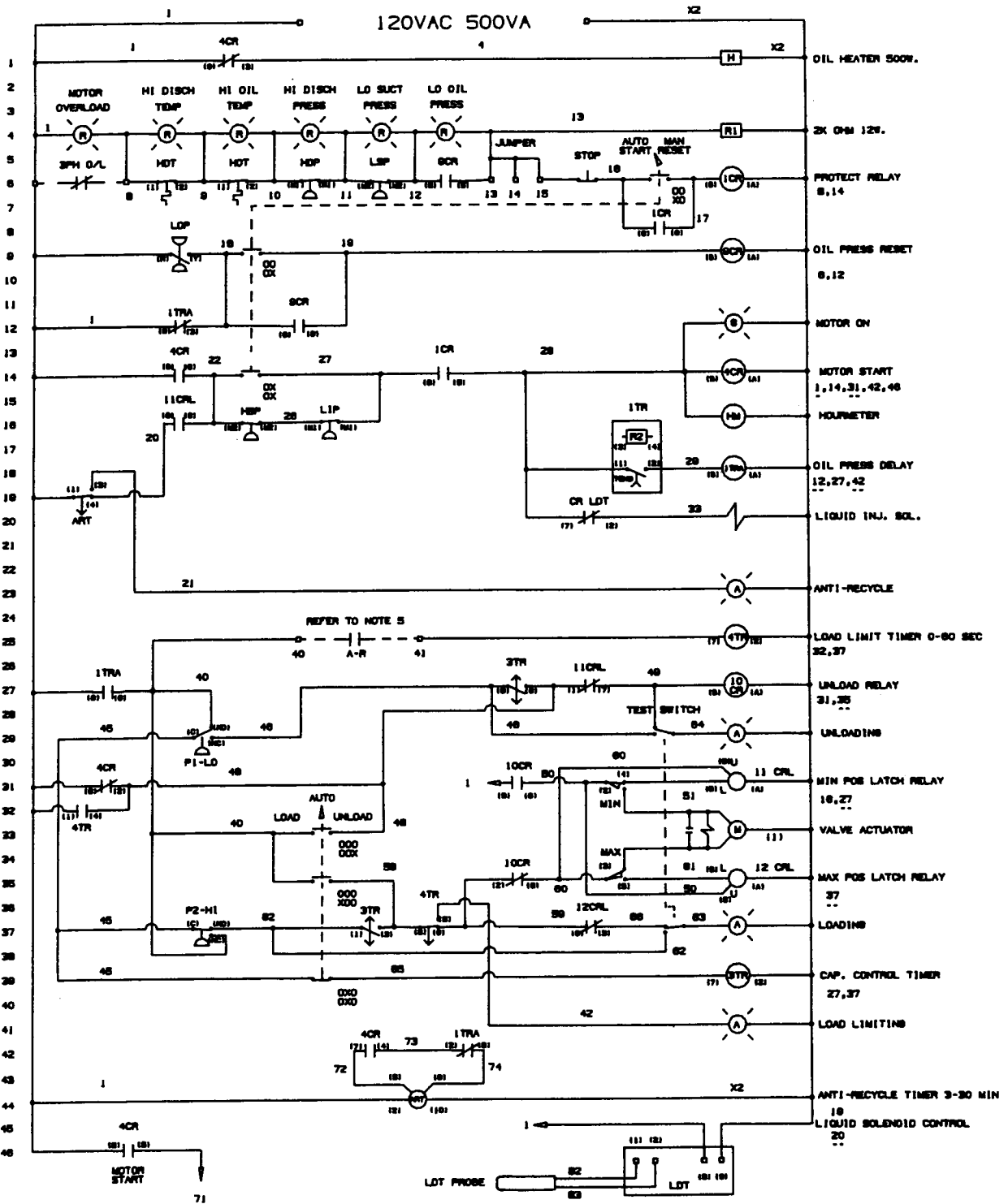

Section 2 DESCRIPTION

tures between the 2 setpoints, the switch calls for the compressor to maintain its capacity.

LOW DISCHARGE TEMPERATURE SWITCH (LDT)

On liquid injection-cooled compressors only, the low discharge temperature switch (LDT) prevents over feed of refrigerant to the oil cooling system. If the discharge temperature drops below the setpoint on the low discharge temperature switch, the main liquid line solenoid valve closes and stops the refrigerant flow to the compressor.

PROTECTIVE CONTROLS

LOW OIL PRESSURE SWITCH (LOP)

The low oil pressure circuit (LOP) consists of a pressure switch and a 10 second delay timer (1TR). During start-up, the low oil pressure switch is bypassed for ten seconds by 1TR to allow the compressor to build-up sufficient oil pressure to close the low oil pressure protective switch. The oil pressure relay (9CR) is energized during normal operation. If the oil pressure falls below the LOP setpoint, after the 10 second override by 1TR, the LOP shuts down the compressor immediately and lights up the red indicating light. The LOP is reset by resetting the protective circuit with the manual RESET pushbutton. A power failure will also result in a low oil pressure indication which must be reset when power is restored.

This switch senses the oil pressure above discharge pressure and is factory set to set points listed in Section 3.3.

HIGH DISCHARGE TEMPERATURE (HDT), HIGH OIL TEMPERATURE (HOT), HIGH DISCHARGE PRESSURE (HDP) AND LOW SUCTION PRESSURE (LSP)

These protective devices are connected in series with the protective relay, 1CR. If the setpoint is exceeded on any switch, the compressor will immediately shut down and light up the red pilot light indicating the malfunction or open circuit. Each must be manually reset on the respective switch after the protect condition has been cleared and then the protective circuit must be manually reset as described under Start Switch description. Refer to Section 4.15 for adjustment.

MOTOR OVERLOAD

A normally closed overload contact from the starter may be wired in series with the 1CR protective relay to shut down the compressor in a motor overload situation, if this protect function is incorporated into the circuit per the appropriate wiring diagram. If the contacts are opened, the protective circuit must be manually reset as described under Start Switch description.

EXTERNAL PROTECTIVE SHUTDOWNS

External shutdowns should be wired in to protect the compressor or systems. These shutdowns would be high level in low pressure receiver, low water or brine temperature or flow, low room tem-

perature etc. These can be installed by removing jumper from Terminals 13 to 14 or 14 to 15. The switch must be installed with closed contacts when in normal operating mode. The protective circuit must be manually reset as described under the Start Switch description.

ANTI-RECYCLE TIMER

The adjustable 0 to 30 minute timer prevents the motor from overheating by limiting the number of motor starts in a given period. It is energized every time the compressor starts and the compressor cannot be restarted until it has elapsed. If the START switch or HSP calls for a restart before the timer has timed out, the circuit will be in a standby condition and the compressor will automatically start when the set time has elapsed. An amber indicator light shows whenever the ART is timing.

The absence of control power will not allow the timer to time out. Control power must be restored to allow the timer to operate. If the compressor has been off for a period of time exceeding the time set on the timer, the timer may be reset to zero to allow immediate start-up, but it should be returned to the previous setting immediately.

After July 1987, the Eagle Signal timer was replaced by a Magnecraft plug-in timer. This timer has a range of 2 to 30 minutes and will automatically reset on power failure. All other functions perform as above.

LOAD LIMIT RELAY

The load limit relay will unload the compressor should the motor draw more than the current setpoint on the load limit relay. The load limit relay and current transformer are to be mounted in the motor starter. An amber indicator will be present when load limiting is in effect.

2.7 CAPACITY CONTROLS

The electric valve actuator (EVA) mounted on the end of the hydraulic cylinder contains a motor which rotates clockwise or counterclockwise and turns the ball screw via a system of gears. The rotation of this ball screw moves a ball nut axially which positions the pilot valve (and the capacity control slide valve as described in Section 2.4).

Limit switches actuated by cams, establish the maximum and minimum capacity positions of the EVA. Refer to Section 7.15 (f) A.C and 7.15 (h) D.C. for adjustment of the cams.

Before a compressor can be started, the capacity control valve must be at minimum position. Whenever the compressor is shutdown for any reason other than power failure, the capacity control valve automatically returns to the minimum position. If a power failure occurs, the capacity control valve will automatically return to the minimum position when power is restored.

The capacity control system is connected through a timer (1TR) such that the compressor cannot

Section 2

DESCRIPTION

load during the initial 10 seconds of running. Once the initial time delay is complete after the initial start, the compressor may load or increase capacity. The capacity control system has an "Auto/Manual" selector, providing for manual or automatic operation. In the "Manual" position (either side of "Auto"), push the button to attain the desired "Load" or "Unload" capacity control action.

A manual override is provided which can be used to vary the capacity control valve position manually without the electrical system. It can be used in the absence of electrical power or in the event of electrical component failure.

In the "Auto" position, the compressor capacity is controlled automatically from the suction pressure by a dual set point adjustable pressure switch (P1/P2). At the desired suction pressure which is between the two switch settings (or in the dead band) no control action occurs and the compressor remains in a constant capacity position. This adjustable dead band is approximately 2 PSI (15 kPa).

Above the high suction pressure setpoint, P2, the compressor loads. Below the low suction pressure setpoint, P1, the compressor unloads. Refer to Section 5.7 (A) or (B) for adjustment of these two pressure settings.

An automatic interrupter timer slows down the valve action so that the speed of response can be set to match individual system characteristics. This dual adjustment timer, 3TR, controls the "on" and "off" time of the capacity control actuator when there is either a load or unload signal. The actuator moves in a step-wise fashion such that the "on" time adjustment varies the length or per cent capacity of each step and the "off" time adjustment varies the number of steps in a given amount of time. Refer to Section 5.7 for adjustment of this timer.

OPTIONS:

Other types of remote pressure or temperature controllers may be adapted to the capacity control system provided the same contact function as described above for P1/P2 is maintained.

A proportional pressure controller is recommended whenever tight control of widely varying loads is required. The proportional capacity control option consists of a pressure transducer (and its power supply) which converts the suction pressure signal into an electrical signal and a solid state electronic controller, which converts the suction pressure signal into an electrical signal. The electronic controller processes this signal and initiates corrective action based upon the difference between the desired suction pressure and the actual suction pressure (pressure error). The magnitude of the control action is propor-

tional to the magnitude of this pressure error: the greater the pressure error, the longer the time the controller remains on and the further the capacity control valve moves. This is shown in Figure 5-2 in Section 5.8. Refer to Section 5.8 for adjustment.

A pneumatic valve actuator (PVA) can be supplied in place of the electric valve actuator.

Two additional cam positions are available for remote signaling.

A capacity meter indicator is available which uses a Wheatstone bridge with a potentiometer. This can be mounted in the control panel or shipped loose for field mounting.

SEQUENCING CONTROL

Refer to Figure 2-11 for a two compressor loading sequence.

In the standard multiple compressor sequence, each compressor will start, load, unload, and stop in a progressive sequence starting with the first or base compressor and adding other compressors as required. A base load transfer (BLT) switch is included to allow equalization of running times by selecting the order of operation, e.g. 1,2,3 or 2,3,1 or 3,1,2. Note that the sequence always remains the same.

With all compressors in "Auto/Start" and "Auto" capacity control, the base or lead compressor will start whenever the suction pressure exceeds a preset value on the "Start/Stop" pressure switch (HSP). Once started, the base compressor will load and unload automatically in response to system demand. If the system demand should be so low that even at minimum capacity the suction pressure falls to an undesirable low value, the HSP switch will stop the compressor and it will remain off until the suction pressure rises to the start-up value.

If the system demand is high and the base compressor is at maximum capacity for a given time (adjustable timer 6TR), the next compressor in the sequence will automatically start and load up to meet the system demand. Subsequent compressors are added in the same manner, each one starting from a maximum capacity signal with an adjustable time delay from the previous compressor in the sequence.

Only the last operating compressor in the sequence will vary in capacity until it is at minimum position.

If several compressors are on and the system demand drops, the last compressor will unload to minimum capacity but will not shutdown until the next to last compressor has unloaded to some adjustable point, usually 40% capacity. This overlapping shutdown sequence prevents unnecessary short cycling by requiring the system de-

Section 2 DESCRIPTION

mand to be well below the capacity of the last compressor before shutting it down.

Note that only the last operating compressor in the sequence will vary in capacity unless it has dropped to minimum capacity at which time the previous compressor will modulate. Only one compressor at a time responds to changes in system demand.

Protective circuit interlocks are provided such that if any compressor in a sequence should shut down due to a malfunction, the next compressor in the sequence will automatically start up and take over.

For more than three compressors in a sequence, a programmable controller is recommended.

REMAINING CONTROLS AND OPTIONAL CONTROLS

OIL HEATER

The oil heater and thermostat are connected through contacts of the starting relays (4CR and 1M) such that the oil heater circuit will be energized whenever the compressor and oil pump are shutdown and the control power is on. The heater is controlled by an integral thermostat (older packages used a separate thermostat). This heater prevents refrigerant from condensing in the oil and raises oil temperature for start-up. For operations outdoors or in unheated engine rooms, additional heat and/or insulation may be required.

PILOT LIGHTS

Pilot indicating lights are typically provided for the following:

1. Motor run (green)
2. Anti-recycle (amber)
3. Motor overload (red)

4. High discharge temperature (red)
5. High oil temperature (red)
6. High discharge pressure/low suction pressure (red) (two separate lights on boosters)
7. Low oil pressure (red)
8. Load (amber)
9. Unload (amber)
10. Load limiting (amber)

Protective device pilot lights are connected in parallel with each device and in series with resistor R1. An open contact causes a voltage difference across the pilot light which causes the light to come on.

HOURLMETER

An hourmeter is supplied to record compressor running time. Since the hourmeter is connected across relay 4CR, the recorded time advances only when the motor is running.

OPTIONAL METER TYPE LOAD LIMIT RELAY

A meter-type load limit relay is available for mounting in starter panel or control panel.

OPTIONAL AREA CLASSIFICATION

Optional electrical equipment is available for water-tight NEMA 4 and hazardous locations NEMA 7 (Class 1, Group D, Division 1 or 2) area classifications.

OPTIONAL CENTRAL CONTROL PANELS

Central control panels and special electrical systems are available as options.

OPTIONAL SYSTEM COMPONENTS

The following additional optional system components are available:

- Dual Filters
- Suction and Discharge Stop Valves
- Microprocessor Control Panel
- Sullistage Economizer

Figure 2-11 Two Compressor Loading Sequence

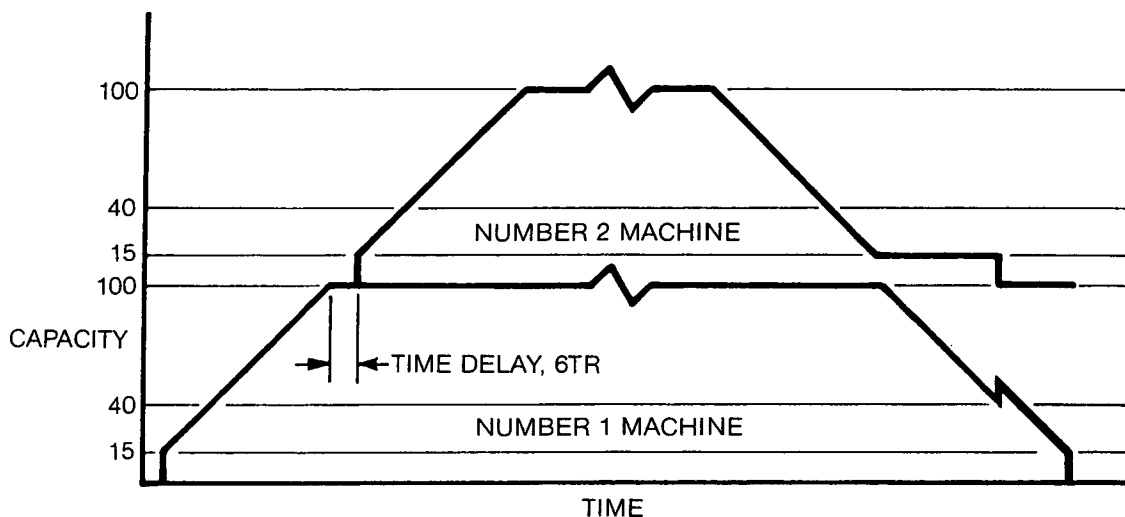

Section 3

SPECIFICATIONS

3.1 GENERAL SPECIFICATIONS

Figure 3-1 and Table 4 show the approximate dimensions, weights and oil capacities for the Sullair "C Series" rotary screw refrigeration compressor packages. Refer to the specific dimensional drawing and wiring diagram for exact details of the compressor furnished.

3.2 MODEL AND SERIAL NUMBERS

On newer packages, the package nameplate is located in the lower right hand corner of the control panel door. The package serial number consists of a five digit number preceded by an "056" or "056-R". The package model number is as shown in Figure 3-2 and is also located on the package nameplate.

On older packages, the package nameplate is located on the EVA side of the control panel.

The compressor unit nameplate is located either on the foot of the compressor or on the top of the discharge housing. The compressor serial number is on the compressor unit nameplate and consists of a series of numbers (006-88000 or 7C25-130) depending on the age of the compressor.

All three numbers are required to fully identify your screw compressor package to Sullair Refrigeration Service and Parts Departments.

The wiring diagram number is on the package nameplate on the electrical control panel door.

3.3 OPERATING LIMITS AND SWITCH SETTINGS

(II)	Anti Recycle Timer, Minimum (ART)	
	100 to 199 HP (75 to 149 kW)	10 Minutes
	200 to 299 HP (150 to 224 kW)	12 Minutes
	300 to 399 HP (225 to 299 kW)	15 Minutes
	400 to 499 HP (300 to 374 kW)	20 Minutes
	500 to 800 HP (375 to 600 kW)	30 Minutes
	Oil Pressure, Above Discharge Pressure	
	Normal	45 PSI to 50 PSI (310kPa to 345kPa)
(I)	Minimum (LOP)	25 PSI (173kPa)
	Maximum	60 PSI (414kPa)
	Oil Pressure Drop Across Filter, Maximum	30 PSI (207kPa)
(I)	Oil Pressure Delay Timer (1 TR)	10 Seconds
	Oil Temperature	
	Normal, Water Cooled	105°F to 115°F (40°C to 46°C)
	Normal, Liquid Injection Cooled	Same as or Slightly Below Discharge Temperature
	Absolute Minimum Before Starting	68°F (20°C) or 10°F (6°C) Above Saturation Temperature of Package Pressure Whichever is Higher
	Ideal Minimum Before Starting	80°F to 100°F (27°C to 38°C)
(II)	Maximum (HOT)	130°F (54°C)
	Oil Heater Thermostat (TH)	105°F (40°C)
	Discharge Pressure	
	Minimum Liquid Injection Cooled	100 PSI (700 kPag)
	Maximum Water Cooled	255 PSI (1.8 MPag)
	Maximum Liquid Injection Cooled	210 PSI (1.5 MPag)
(II)	Maximum (HDP)	20 PSI (150kPa) Below System Relief Valve
	Discharge Temperature	
(II)	Low, Liquid Injection Cooled (LDT)	105°F (40°C) or 10°F (6°C) Above Condensing Temperature Whichever is Higher
(II)	Maximum, Water Cooled (HDT)	195°F (90°C)
(II)	Maximum, Liquid Injection Cooled (HDT)	140°F (60°C)
	Normal,	118°F (48°C) to 122°F (50°C) or 10°F (5°C) Above Saturated Temperature at Discharge Pressure Whichever is Higher

Section 3 SPECIFICATIONS

Suction Pressure				
P1/P2 Setting				
P1 Unload, Below Desired Suction Pressure	1 PSI to 2 PSI (7kPa to 15kPa)		
P2 Load, Above Desired Suction Pressure	1 PSI to 2 PSI (7kPa to 15kPa)		
HSP Setting				
Low (Compressor Stop or Cut Out), Below P1 Pressure	5 PSI to 15 PSI (35kPa to 100kPa)		
High (Compressor Start or Cut In), Above P2 Pressure		2 PSI to 5 PSI (15kPa to 35kPa)		
LSP Setting				
(II) Minimum, Below Low Setting of HSP		2 PSI to 5 PSI (15kPa to 35kPa)		
Maximum	See Table 3		
Suction Temperature				
Maximum Superheat, Ammonia R12 or R22	20°F (7°C)		
Suction/Discharge Differential Pressure, Maximum		275 PSID (1.9 MPa)		
Water Temperature, Maximum Inlet Design		85°F (30°C)		
Ambient Compressor Room Temperature				
(III) Minimum	50°F (10°C)		
(IV) Maximum	104°F (40°C)		
Compressor Speed				
Model	C16	C20	C25	C40
Maximum RPM	5900	4700	3800	2300
Minimum RPM	2900	2900	2900	1200

NOTES

- (I) This is a factory preset and sealed to the above setting. Tampering with this device constitutes abuse of the compressor under the terms of the warranty.
- (II) Set all protective devices and control switches to the above values.
- (III) If the compressor is to be operated in an unheated room of 50°F (10°C) or lower, special modifications may be required (consult Sullair Refrigeration).
- (IV) If the compressor is to be operated in a machine room of 104°F (40°C) or higher, a motor having a higher class of insulation than Class B (standard) may be required (consult Sullair Refrigeration).

For halocarbon or hydrocarbon system or other special systems, special operating points may be required. Consult Sullair Refrigeration Service Department.

TABLE 3

VOLUME RATIO	MAXIMUM INLET OPERATING PRESSURE							
	2.2		2.6		3.5		5.0	
	PSIG	kPag	PSIG	kPag	PSIG	kPag	PSIG	kPag
Ammonia	-	-	100	690	65	450	40	275
R-22	120	830	110	750	75	520	47	325

3.4 OIL SPECIFICATIONS

The oil specified for use in Sullair Ammonia Refrigeration screw compressors is a refrigeration oil with a low pour point having a kinematic viscosity of 300 Saybolt Seconds Universal (SSU) at 100°F which is equivalent to 68 centistokes (cSt) at 40°C. The oil shall not contain anti-wear addi-

tives. Sullair Refrigeration Service Department maintains a list of approved oils. For halocarbon or hydrocarbon applications the oil will become diluted with the refrigerant. Therefore, oil selection must be verified with Sullair Refrigeration Department.

Section 3 SPECIFICATIONS

Figure 3-1 Package Dimensions

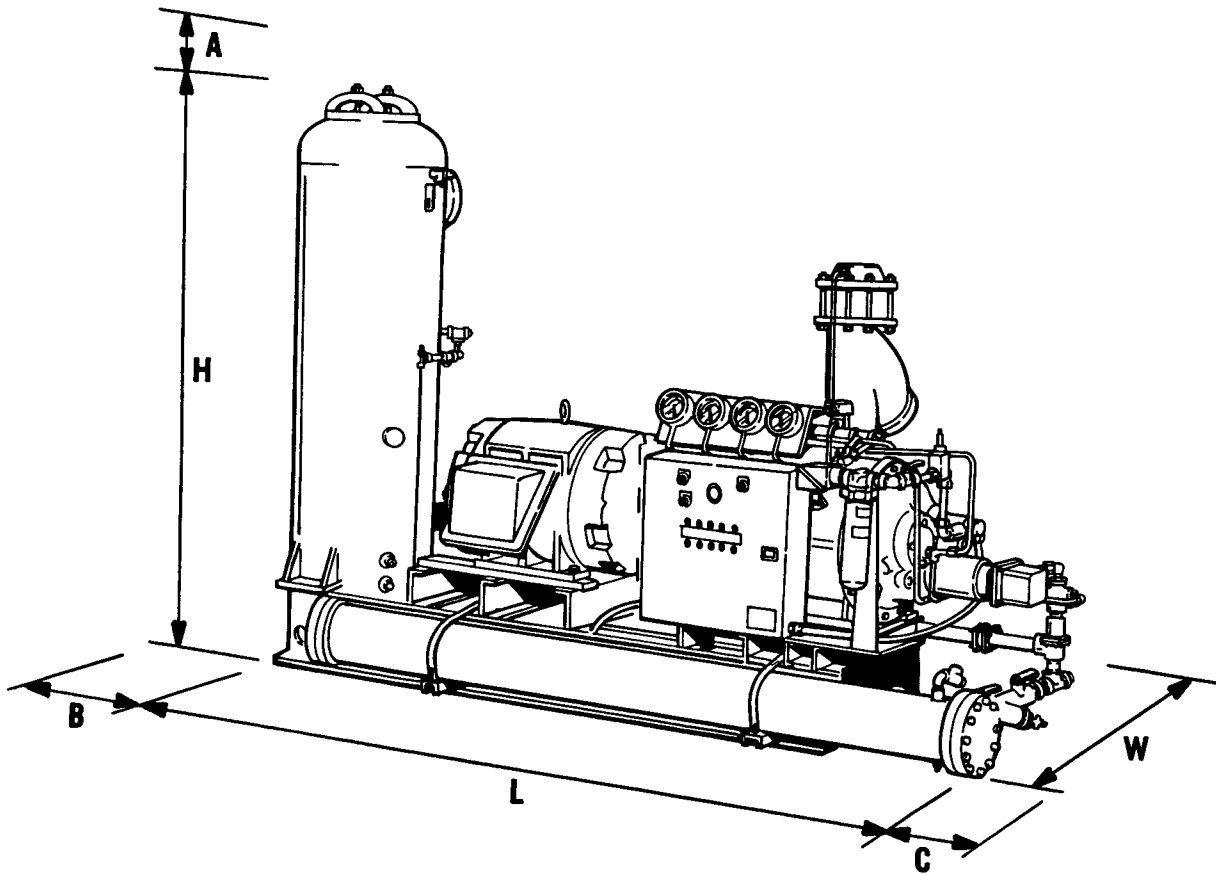

Figure 3-2 Model Number Nomenclature

<p>Rotor Diameter: 16, diameter 163mm 20, diameter 204mm 25, diameter 255mm 40, diameter 408mm</p>	<p>Type of Operation: A, high stage or single stage B, booster or low stage</p>	<p>Volume Ratio: 2.2, Ultra Low Compression Ratio 2.6, Low compression ratio 3.7, Intermediate compression ratio 4.8, High compression ratio</p>	
<p>Compressor: Series</p>	<p>Rotor Length: L, rotor $\frac{\text{length}}{\text{dia.}} = 1.7$ M, rotor $\frac{\text{length}}{\text{dia.}} = 1.25$ S, rotor $\frac{\text{length}}{\text{dia.}} = 1.15$</p>	<p>Refrigerant: 012, R12 022, R22 717, ammonia</p>	<p>Motor Power: 200, Motor HP</p>

Section 3 SPECIFICATIONS

TABLE 4
PACKAGE DIMENSIONS Refer to Figure 3-1.

MODEL	DIMENSIONS											
	LENGTH		WIDTH		HEIGHT		A (I)		B (II)		C (II)	
	in	m	in	m	in	m	in	m	in	m	in	m
C16LA	123	3.12	40	1.02	88	2.24	20	0.51	135	3.43	120	3.05
C16LB	123	3.12	40	1.02	88	2.24	26	0.66	135	3.43	120	3.05
C20SA	136	3.45	41	1.04	95	2.41	20	0.51	116	2.95	122	3.10
C20SB	123	3.12	41	1.04	95	2.41	20	0.51	108	2.74	132	3.35
C20LA	136	3.45	44	1.12	95	2.41	20	0.51	95	2.41	106	2.69
C20LB	127	3.23	41	1.04	95	2.41	26	0.66	108	2.74	132	3.35
C25SA	165	4.19	56	1.42	102	2.59	20	0.51	83	2.11	126	3.20
C25SB (III)	165	4.19	54	1.37	102	2.59	26	0.66	63	1.60	117	2.97
C25MA	165	4.19	57	1.45	102	2.64	20	0.51	80	2.03	126	3.20
C25MB (III)	165	4.19	54	1.37	102	2.59	26	0.66	63	1.60	117	2.97
C25LA	172	4.37	56	1.42	115	2.92	26	0.66	107	2.72	144	3.66
C25LB (IV)	172	4.37	56	1.42	115	2.92	33	0.84	38	0.96	105	2.67
C40LA	267	6.78	78	1.98	130	3.30	33	0.84	100	2.54	130	3.30
C40LB	243	6.17	78	1.98	130	3.30	33	0.84	100	2.54	130	3.30

(I) Height needed to remove oil separator elements.

(II) Clearance for oil cooler tube cleaning (need only one, as tubes can be cleaned from either end).

(III) Prior to 1987, dimension 165 (4.19) was 135 (3.43) and dimension 63 (1.60) was 102 (2.59).

(IV) Prior to 1987, dimension 172 (4.37) was 145 (3.68) and dimension 38 (0.96) was 90 (2.29).

MODEL	CONNECTIONS/VALVES (VI)								APPROX. WEIGHT WITH MOTOR (VIII)		NOMINAL FLUID CHARGE	
	REFRIGERANT (V)						WATER					
	SUCTION		DISCHARGE		LIQUID (VII)		OIL COOLER		lb	kg	gal	L
	in	mm	in	mm	in	mm	in	mm				
C16LA	5/4	127/102	3	76	1/2	13	2	51	5000	2300	30	114
C16LB	5/4	127/102	3	76	1/2	13	2	51	5000	2300	30	114
C20SA	6/5	152/127	4/3	102/76	3/4	19	2	51	6200	2800	35	132
C20SB	6/5	152/127	4/3	102/76	1/2	13	2	51	6200	2800	35	132
C20LA	6/5	152/127	4	102	3/4	19	2 1/2	64	6500	3000	40	151
C20LB	6/5	152/127	4	102	1/2	13	2	51	6500	3000	35	132
C25SA	6	152	5/4	127/102	3/4	19	2 1/2	64	10000	4500	60	227
C25SB	6	152	5/4	127/102	1/2	13	2 1/2	64	10000	4500	55	208
C25MA	6	152	5/4	127/102	3/4	19	2 1/2	64	11500	5200	60	227
C25MB	6	152	5/4	127/102	1/2	13	2 1/2	64	11500	5200	55	208
C25LA	8	203	5	127	1	25	2 1/2	64	11500	5200	90	341
C25LB	8	203	5	127	3/4	19	2 1/2	64	11500	5200	85	322
C40LA	10	254	6	152	1 1/4	32	3	76	23000	10500	120	454
C40LB	10	254	6	152	3/4	19	2 1/2	64	27000	12000	100	379

(V) Recommended customer minimum line sizes for Sullistage are:

C16L: 1 inch (25mm), C20S: 1 1/4 inches (32mm), C20L: 1 1/2 inches (38mm),

C25S: 2 inches (51mm), C25M: 2 inches (51mm), C25L: 2 inches (51mm), C40L: 3 inches (76mm)

(VI) Connection/Valve sizes are for NH₃ refrigerants. Sizes may vary for other refrigerants.

(VII) Recommended customer minimum line size. Sullair liquid injection size from customer line to compressor connection is 3/4 in (19mm) for all compressors except 1/2 inch (13mm) for C16LB and C20SB, and 1 inch (25mm) for C40L.

(VIII) Larger motors may increase weight 25%.

Section 3

SPECIFICATIONS

⚠ WARNING

Used or filtered oil should NEVER be added to a refrigeration screw compressor under any circumstance. Use only new oil from an oil manufacturer (any of the major oil companies or their approved dealers).

The oil must be changed every three months or 2000 hours unless the oil quality is assured by a qualified oil laboratory, or a synthetic oil is used with an approved extended life. See Section 6.5 for further details of oil analysis.

Should you have other types of compressors in your system, it is recommended that you investigate changing their oil grade to that of the screw compressor. The screw compressor oil is usually satisfactory in other types of compressors, but the compressor manufacturer must be consulted for approval. This will minimize any possibility of the incorrect grade being added to the compressor.

Sullair Refrigeration assumes no responsibility for the quality, performance, availability, viscosity or pour point of the recommended oil products.

3.5 MOTOR SPECIFICATIONS

All motors, whether Sullair supplied or customer supplied, are to be 3600 RPM (3000 RPM for 50 Hz

system) and of adequate starting power for operating conditions. The C40L requires an 1800 RPM motor (1500 RPM for 50 Hz). Operation at any other speeds must be approved by Sullair Refrigeration as special packaging may be required.

All motors must provide adequate torque to fully accelerate the compressor to full speed within time restrictions specified by the motor vendor. The motors (induction type) shall not exceed the following Nema Standard 7-16-1969 vibrational limits:

<u>SPEED, RPM</u>	<u>MAX. AMPLITUDE, IN. PK-PK</u>
3000 AND ABOVE	.001
1500-2999, INCL.	.002

Motors should have a minimum starting torque greater than the required operating torque at minimum capacity. A standard across-the-line starter normally meets this requirement. For other types of starting or where there are problems starting, consult Sullair Refrigeration Service for assistance.

Check that the power supply can provide the required starting current without causing excessive voltage drops in the supply grid. If there is any question of the availability of adequate starting torque, contact Sullair Refrigeration Service for a detailed speed torque analysis.

Section 4

INSTALLATION

4.1 GENERAL

This Section contains instructions for the proper installation of Sullair "C Series" Refrigeration Screw compressors. All items in this section must be completed by those with installation responsibility before the Sullair Refrigeration representative arrives for start-up. For answers to any specific questions about installation procedures, please contact Sullair Refrigeration Service Department.

4.2 START-UP SERVICE OUTLINE

The following items are tasks that must be completed before the Sullair Refrigeration Representative arrives at the job site.

1. The compressor is to be leveled, securely anchored to the foundation and grouted to assure stability of the coupling alignment as in Section 4.4.
2. All refrigeration piping is to be completed. Relief valves are to be properly vented.
3. All piping is to be supported so that it does not exert loads on the compressor or separator.
4. The water piping is to be completed with the water valve installed for water-cooled compressors as in Section 4.6.
5. The refrigerant piping is to be completed for the refrigerant-cooled compressors as in Section 4.7.
6. The system and the compressor package are to be pressure-tested for leaks as in Section 4.8.
7. The system is to be evacuated to remove air and moisture as in Section 4.9.
8. The coupling is to be aligned within the specifications in Section 4.10. The Sullair Refrigeration Representative will check the coupling alignment and rotation before starting the compressor, so the coupling should not be re-assembled after the alignment is completed.
9. The electrical wiring is to be completed as per wiring diagrams. **DO NOT** energize the compressor control panel until oil is added or the oil heater is disconnected.
10. The compressor is to be filled with the correct type (Section 3.4) and amount of lubricating oil (see Section 4.12).
11. The oil is to be warmed up per Section 4.13.
12. The control panel is to be energized to check the protective switches and the capacity control as in Sections 4.14, 4.15, 4.16 and/or 4.17.
13. The direction of rotation of the motor and pump are to be checked (see Section 4.18).
14. The motor is to be lubricated per Section 4.19.
15. Have available two dowel pins, drill and reamer for the motor. The motor will be dowel-pinned by the customer after the alignment is checked by the Sullair Refrigeration Representative.

The Sullair Refrigeration representative will supervise the following with customer-supplied labor:

1. Check the general installation.
2. Check the coupling alignment. Customer will then dowel-pin the motor.
3. Check all electrical protective controls.
4. Start the compressor for the first time and adjust all the package valves and controls.
5. Set capacity control actuator adjustment.
6. Explain compressor operation to the operating personnel.

4.3 COMPRESSOR STORAGE

The compressor package should be stored at all times in a dry location to prevent corrosion damage. The suction and discharge lines are covered for shipment and short term storage. If the unit is to be stored for a prolonged period of time, a holding charge of dry nitrogen must be installed to 4 or 5 PSI (28kPa or 35kPa) above atmospheric pressure. This will prevent corrosion from any moisture that might enter the compressor package.

Periodically the compressor package must be checked by:

1. Verifying the nitrogen has not leaked out.
2. Pumping a couple of gallons of oil through the filter to the bearings (using auxiliary oil pump or separate oil pump).
3. Lubricating the motor bearings per motor manufacturer's recommendation.
4. Installing a desiccant inside of the control panel and starter.
5. Rotating the motor and compressor to minimize bearing pressure.

4.4 FOUNDATION AND RIGGING

The compressor package can be mounted and secured to any hard rigid and level surface which is adequate to support the weight of the package. Since the screw compressor is a relatively vibration-free rotary compressor, it does not have to be mounted on an inertia block or pad.

Check the foundation anchor bolt spacings with the hole spacings in the package frame base.

Lift the package by placing slings under each end of the complete assembly. Use spreader bars or timber under the slings to prevent damage to the piping and components. **DO NOT** sling from the pipework, the suction strainer or the eyebolt holes in the motor. Eyebolts have been provided for lifting component pieces only and not the entire package. **DO NOT** fork lift the package without taking precautions against tipping as the package is top-heavy.

If the mounting surface is not level, use shims under the frame to level in both directions to distribute the weight evenly over the entire frame. Any major distortion of the frame when the anchor bolts are tightened will complicate the alignment of the compressor. In multiple compressor installations of 350HP (260Kw) or larger or in locations with excessive floor vibration, it may be necessary to mount the package on an inertia block or

Section 4

INSTALLATION

pad and isolate the package and pad from the floor.

Vibration isolation equipment can be effectively used only if flexible connectors are used in the piping and electrical conduit.

DO NOT overtighten or pin the oil separator to the package frame, since thermal expansion of the discharge line must not be restricted.

DO NOT grout the package frame to the foundation at this stage. Grouting with an expanding grout around the entire base is necessary after the refrigerant piping is connected and the compressor and motor are roughly aligned (approximately $\frac{1}{32}$ " [1mm] total indicated reading). The grouting will then minimize any base deflections that may affect the coupling alignment.

4.5 REFRIGERANT PIPING

All piping must conform to Federal, State and Local codes and good industrial practice (e.g. ANSI 31.5, ANSI/IIAR 74-2 and ASHRAE Systems Handbook). The customer must supply piping, fittings and equipment (as shown in Piping Schematics and Wiring Diagrams in Section 2) up to the terminating connections on the Sullair package. The size and location of the refrigerant suction, discharge, liquid and Sullistage and water connections can be found on the dimensional drawing of the package. For standard compressors, the sizes of the connections are given in Table 4.

The suction line and discharge line should be installed and supported such that there is no load exerted on the compressor frame from either static forces or vibration. External forces from the piping can distort the coupling alignment and cause major bearing and shaft seal problems.

GASKET JOINTS

When using flanges, a $\frac{1}{16}$ " (1.6mm) fiber gasket should be used. Prior to tightening flange bolts the pipe to be connected should be in parallel alignment, and the bolt holes should be in line. **DO NOT** use flanges as a means of straightening pipe as they may stress adjacent compressors, valves and controls.

Flange bolts should be drawn up evenly, when connecting flanges, to prevent flange breakage.

THREADED JOINTS

The use of litharge and glycerine for sealing threaded joints has been replaced by many commercially available compounds and sealing tapes designed for use with different refrigerants. Check for compatibility and follow instructions accompanying these compounds for method of application. **DO NOT** use excessive amounts or apply on female threads, because any excess could contaminate the system.

WELDED JOINTS

⚠ WARNING

Back-up weld rings should be used in all joints in the suction and discharge lines to minimize the amount of weld slag inside the system pipes.

All steel lines (especially suction, Sullistage, and liquid injection lines) should be thoroughly cleaned, for example, by power rotary wire brushing and blowing out with compressed air.

DO NOT ground through the compressor when arc welding.

4.6 COOLING WATER SUPPLY REQUIREMENTS

⚠ WARNING

A water supply temperature of 85°F (30°C) or lower is required unless special design considerations have been made. The Sullair Selection Guide gives the procedure for calculating the required water flow rate. To design the water piping and select the pump, allow a minimum pressure drop through the oil cooler and the 2-way valve of 20 PSI (138kPa) unless checked by Sullair Refrigeration.

The oil cooler will require water supply and drain lines with a control valve that will regulate the water flow to maintain the oil temperature. Figures 4-1 and 4-2 show typical piping arrangements for 2-way and 3-way water valves for the oil cooler system.

⚠ WARNING

To properly vent the cooler and prevent air buildup in the cooler, the water inlet should be piped into the lowest connection in the cooler head.

The 2-way water regulating valve supplied with the compressor should be installed on the inlet side of the cooler with the temperature-sensing bulb inserted into the bulbwell in the oil line leaving the oil cooler. 3-way regulating valves must be installed per valve manufacturer's recommendations.

⚠ WARNING

The bulb should be coated with aluminum paste or heat transfer grease before inserting it into the bulbwell to improve heat transfer between the bulb and the bulbwell.

Manual bypass valves are recommended to allow for water supply to the cooler in case the water

Section 4 INSTALLATION

Figure 4-1 Recommended Water Piping Schematics for Single Oil Cooler System

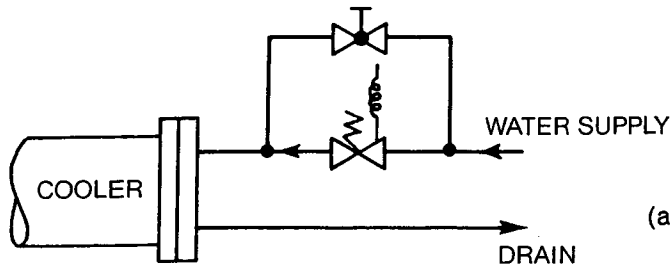

(a) 2-Way Valve with Manual Bypass Valve

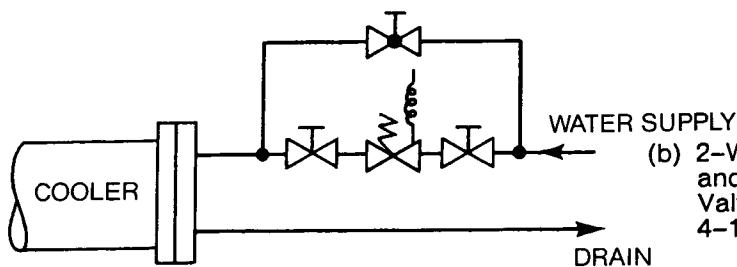

(b) 2-Way Valve with Maintenance Stop Valves and Manual Bypass Valve, Maintenance Stop Valves may also be Included in Figures 4-1(c), 4-1(d), 4-2(b) and 4-2(c).

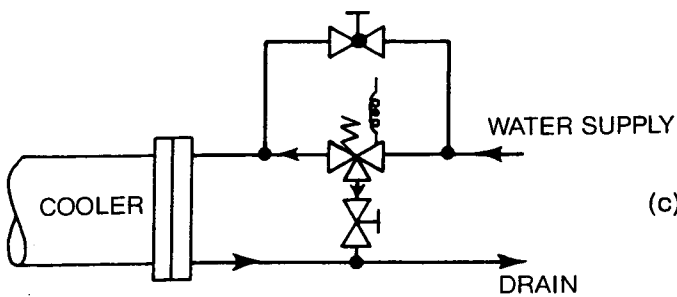

(c) 3-Way Diverting Valve with Balancing Valve and Manual Bypass Valve

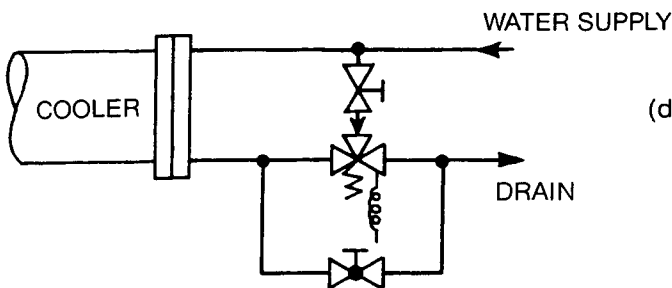

(d) 3-Way Mixing Valve with Balancing Valve and Manual Bypass Valve

Section 4 INSTALLATION

Figure 4-2 Recommended Water Piping Schematics for the Two Oil Cooler System

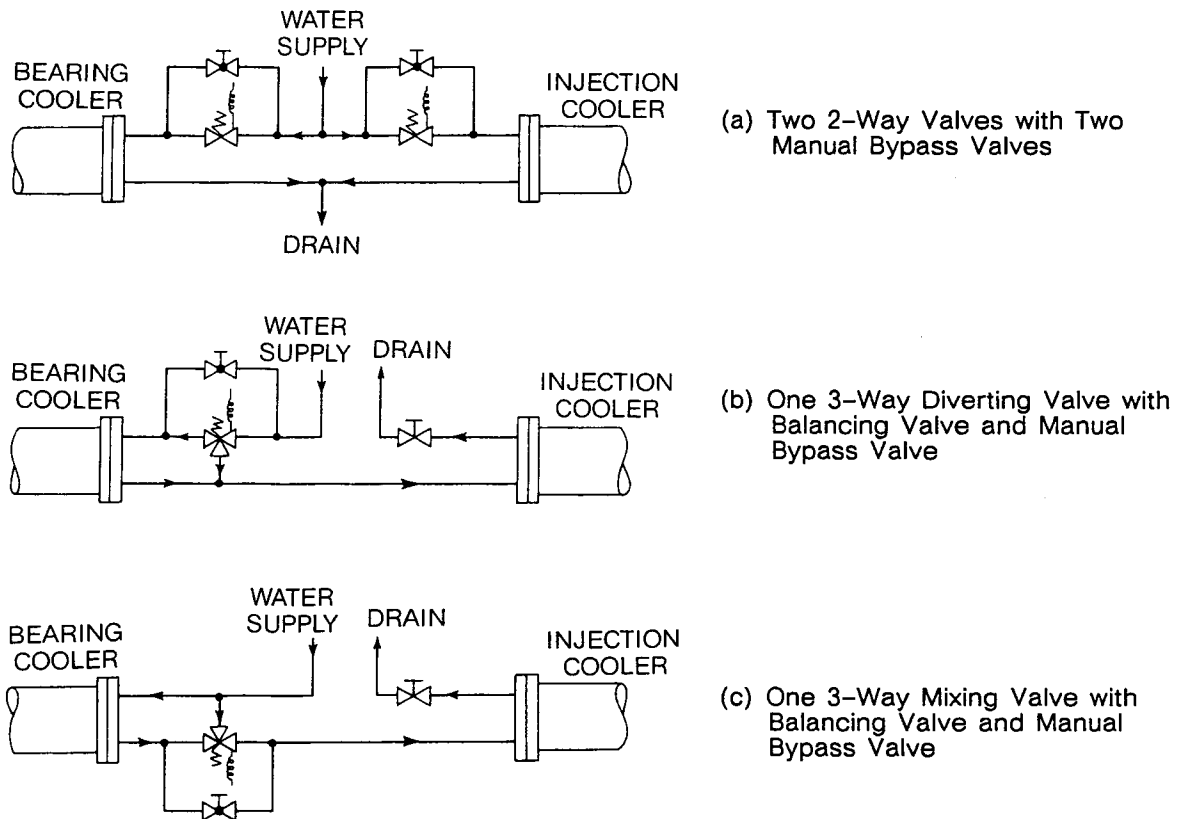

regulating valve becomes inoperative. A water solenoid valve is also recommended to stop the water flow upon shutdown.

Optional 3-way water regulating valves are available. If a 3-way valve is used, a manual pressure balancing valve is recommended in addition to a manual bypass valve and a water solenoid valve.

The water supply to the cooler should be treated to minimize fouling of the oil cooler due to scale, corrosion, algae growth, dirt etc. Additives, filtering and bleed-off should be used where necessary. If the water supply will not be reasonably treated, special consideration must be given to the oil cooler design (contact Sullair Refrigeration Service) and the water piping should be designed to maintain a high water velocity of approximately 10ft./sec. (3 m/s) to minimize fouling.

The alternative sources of cooling water for water-cooled compressors are outlined below:

OPEN CIRCUIT RECIRCULATED EVAPORATIVE CONDENSER PAN WATER

The most common source of cooling water for the oil cooler is from the evaporative condenser pan or a cooling tower pan. In most applications, the

condenser size is the same as for a comparably-sized reciprocating compressor. Contact Sullair Refrigeration or your condenser (or cooling tower) supplier for specific recommendations on loads and sizing.

This source of cooling water has the advantages of the lowest operating cost and simplicity.

The disadvantages of this method are that the cooling water is contaminated with dissolved or suspended air-borne particles and pollution which causes excessive scaling and fouls the oil cooler tubes, and the potential for winter freeze up is great in the colder climates.

CLOSED CIRCUIT RECIRCULATED EVAPORATIVE COOLING

By using a circuit of the evaporative condenser and circulating a captive charge of coolant to the oil cooler, scale build up and fouling of the tubes is minimized and the winter freeze hazard can be eliminated with the use of a glycol or brine.

The disadvantage of this method is the expense of the evaporative cooler and the possibility of an oversized oil cooler due to higher water (glycol) temperatures.

Section 4 INSTALLATION

ONCE THROUGH WELL OR CITY WATER

If a low cost source of water is available, it is possible to cool the oil and return the warm water to a drain. Special consideration must be given to the oil cooler design if the water will not be treated and cleaned.

4.7 COOLING REFRIGERANT SUPPLY REQUIREMENTS

Figure 4-3 is a schematic of direct liquid injection oil cooling and the components and connections supplied with the Sullair package. For refrigerant cooling of Sullair Refrigeration compressors by direct liquid injection, a reliable source of high pressure liquid must be supplied to the compressor by the owner. The system must be such that the cooling liquid supply is always available to the compressor whether or not liquid is present in the high pressure receiver. A minimum of a five minute supply of liquid should be available to the compressor cooling system after the high pressure receiver is empty for any reason. Table 5 gives line sizes and vessel sizes for the specific compressor. Note that the customer minimum line sizes are different from the Sullair line sizes. Contact Sullair Refrigeration for any additional information you may require.

Line lengths from the high pressure receiver to the compressor should be as short as possible to insure an adequate liquid supply at start-up. The piping must allow free venting of any vapor that may be created on shutdown.

To minimize evaporation of liquid in the supply line with consequent reduction in liquid flow through the refrigerant regulating valve, the line should be insulated if it passes through an area where the temperature is higher than the condensing temperature (e.g. in the open, under the hot sun, or inside warm rooms in cold climates).

Three methods are shown in Figure 4-3A.

System "A" consists of modifying the existing high pressure receiver or modifying the design of a new high pressure receiver such that two liquid supply lines are available; one to the evaporator and one for the cooling liquid supply. The connection must be situated such that the liquid will stop flowing to the evaporator before it stops flowing to the compressor. Again, a minimum of five minutes supply must be available to the compressor.

System "B" consists of a solenoid valve connected to the liquid supply line from the high pressure receiver to the evaporator. The solenoid valve is controlled by a level switch installed in the high pressure receiver and set such that the solenoid valve will close when the liquid level in the tank drops to a point where slightly more than five minutes of liquid remains in the tank.

System "C" consists of installing a small auxiliary high pressure vessel, sized to hold the five minute liquid supply.

THERMOSIPHON COOLING

Piping for thermosiphon cooling must be sized to supply adequate supply of liquid to the cooler and return the combination of gas and liquid to the pilot receiver. Lines must be sized to allow only a couple PSI pressure drop. Sullair Refrigeration should be contacted for assistance in sizing these lines.

4.8 PRESSURE TEST FOR LEAKS

The Sullair Refrigeration package components have all been pressure-tested prior to leaving the factory to the "Safety Code for Mechanical Refrigeration" ANSI B9.1, 1977. The compressor unit should, however, be leak-checked at the job site to detect leaks which may be present due to rough handling during shipment.

This test should be done simultaneously with the system pressure test and system leak check.

DO NOT add oil to the package prior to pressure testing.

⚠ WARNING

Whenever the compressor package is colder than the equivalent condensing temperature at the test pressure, then dry nitrogen or dry air should be used to bring the package up to the design pressure less 20% given in Table 6.

Before the system pressure test, check that the oil separator elements are seated correctly and that the gaskets are in the correct position. When the package is under pressure, tighten the oil separator manhole cover.

In the absence of an established pressure testing procedure, the following is a guide to good practice.

⚠ WARNING

To prevent premature leakage of relief valves, leak testing should be accomplished at 80% of the relief setting of the relief valves.

1. Open all interconnecting valves between the low and high pressure sides. Open solenoid valve, pressure regulating valves, check valves and other control valves by means of their manual lifting stems.
2. Pressure-test the entire system with dry nitrogen or dry air to the low side pressure given in Table 6 or 80% of the setting of the pressure relief device protecting the low side.

⚠ WARNING

If using an air compressor, a dryer must be used to reduce the moisture content.

Section 4 INSTALLATION

Figure 4-3 Ammonia Piping for Liquid Injection-Cooling

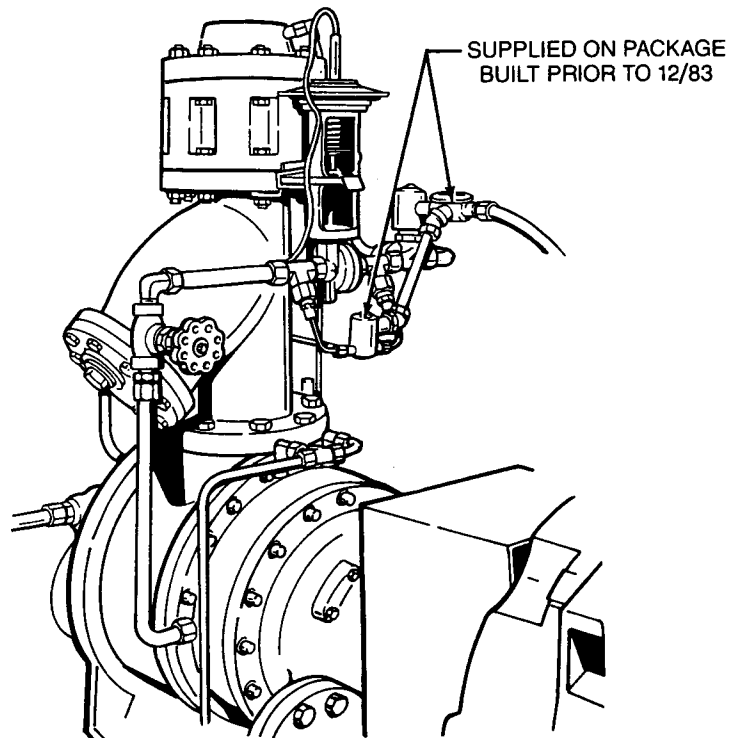
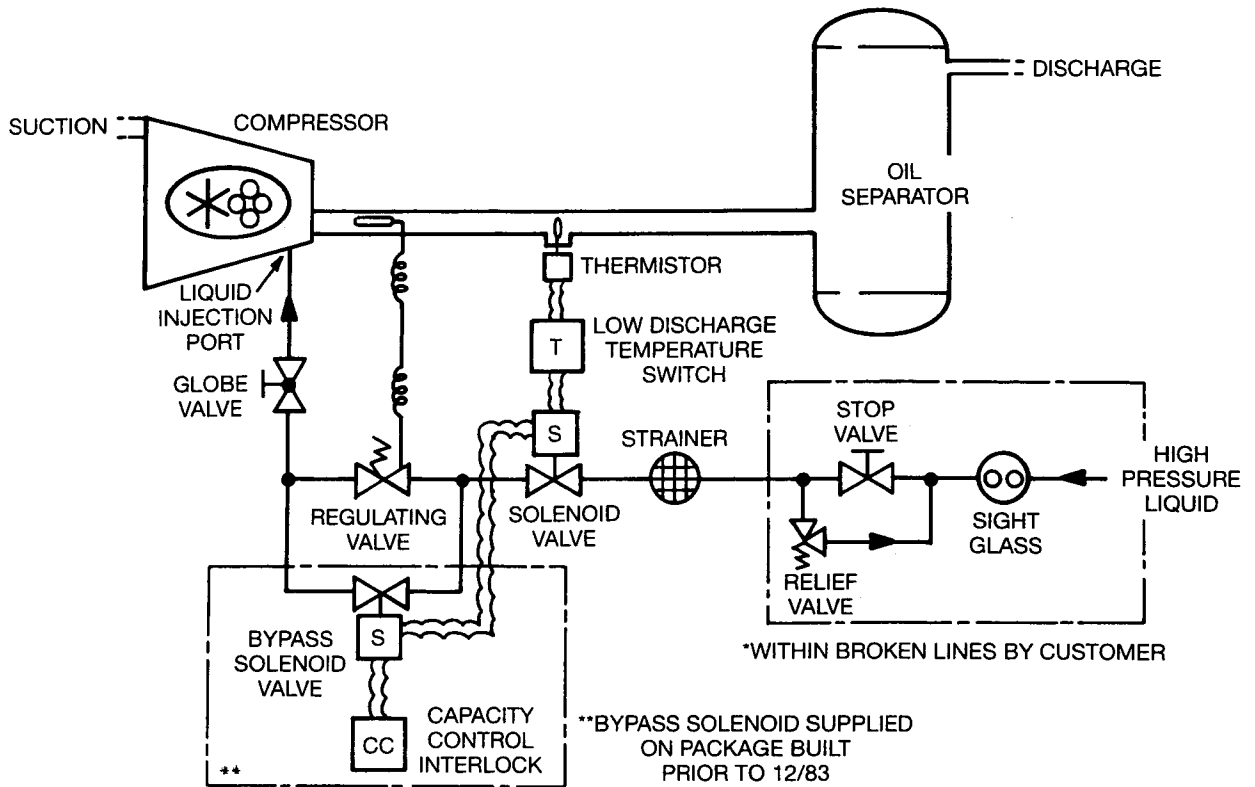

Section 4 INSTALLATION

Figure 4-3A Refrigerant Supply Methods for Liquid Injection-Cooling

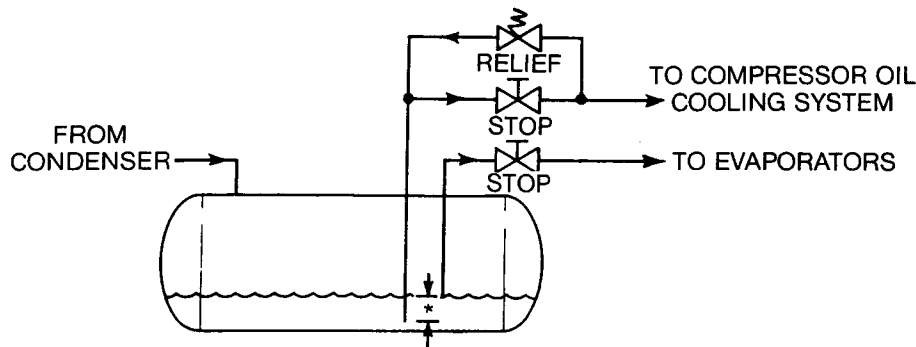

*Level difference to provide minimum of 5 minutes liquid supply for compressor oil cooling system.

(a) Modified High Pressure Liquid Receiver Method.

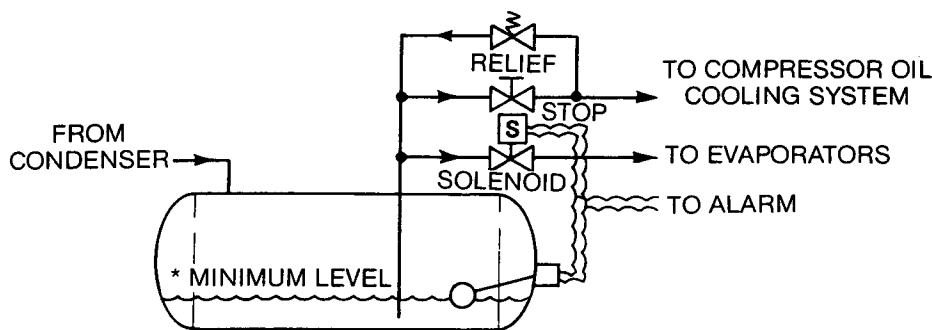

*Solenoid valve closes at this level. A minimum of 5 minutes liquid supply remains in the receiver for compressor oil cooling system

(b) Level Control And Solenoid Valve Method.

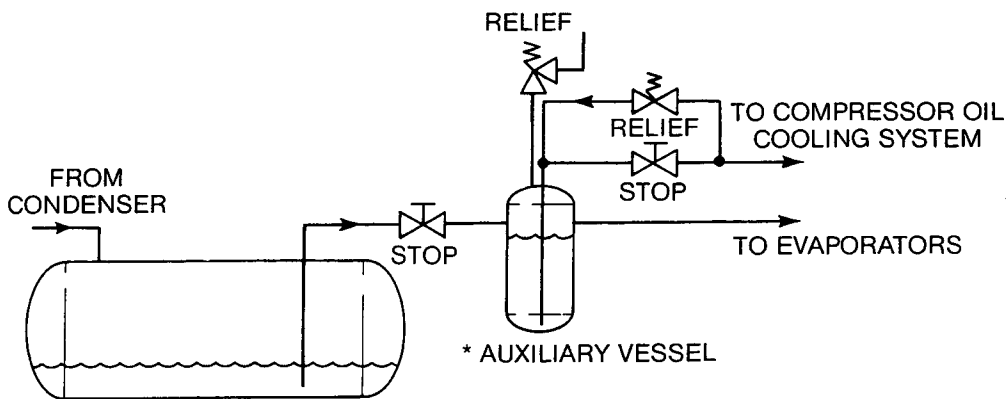

*Auxiliary vessel sized to provide minimum of 5 minutes liquid supply for compressor oil cooling system.

(c) Auxiliary Vessel Method.

Section 4 INSTALLATION

3. Blow down the system and repair any leaks.
4. Again, pressure-test the entire system to the low side pressure as in Step 2 but add 1% of the system refrigerant charge to aid leak detection.
5. If no leaks are found, record the pressure and the ambient temperature and hold the system pressurized for 12 hours (overnight). Note the system pressure and the ambient temperature after 12 hours. Correct the pretest pressure for temperature variation (as the absolute pressure is proportional to the absolute temperature) as in the example below. If the pretest temperature corrected pressure has not decreased by more than 0.5% of the test pressure, the low side system can be considered

leak-free for refrigeration purposes.

For example, consider a low side ammonia system where the pretest pressure was 150 PSIG (1034kPa) at an ambient temperature of 81°F (27°C) and the test pressure reduced to 144 PSIG (992kPa) at an ambient temperature of 61°F (16°C). The pretest pressure is corrected for the temperature variation as follows:

$$P_c = \frac{(61 + 459)}{(81 + 459)} \times (150 + 14.7)$$

$$= 159 \text{ PSIA (1096kPa)}$$

$$= 144.3 \text{ PSIG (992kPa)}$$

TABLE 5
AMMONIA LINE SIZING FOR LIQUID INJECTION COOLING

MODEL	SULLAIR LINE SIZE		CUSTOMER MINIMUM (I) LINE SIZE		MINIMUM LIQUID SUPPLY VOLUME	
	inches	mm	inches	mm	ft ³	L
C16LA	3/4	19	1/2	13	2	57
C16LB	1/2	13	1/2	13	1	28
C20SA	3/4	19	3/4	19	2	57
C20SB	1/2	13	1/2	13	1	28
C20LA	3/4	19	3/4	19	3	84
C20LB	3/4	19	1/2	13	1	28
C25SA	3/4	19	3/4	19	4	112
C25SB	3/4	19	1/2	13	1 1/2	42
C25LA	3/4	19	1	25	6	170
C25LB	3/4	19	3/4	19	2	57
C25MA	3/4	19	3/4	19	5	140
C25MB	3/4	19	1/2	13	1 1/2	42
C40LA	3/4	19	1 1/4	32	10	280
C40LB	3/4	19	3/4	19	4	112

(I) Larger sizes should be used when the calculated pressure drop of the liquid flow (in the piping within the dashed lines of Figure 4-3) exceeds 4 PSI (28kPa).

TABLE 6
MINIMUM DESIGN PRESSURES

REFRIGERANT	LOW SIDE		HIGH SIDE			
	PSIG	kPag	WATER-COOLED		AIR-COOLED	
			PSIG	kPag	PSIG	kPag
R12	100	700	150	1000	200	1400
R22	150	1000	300	2000	300	2000
R717	150	1000	250	1700	300	2000

Section 4 INSTALLATION

The minimum pressure of an acceptable leak-free system is 99.5% of P_c which is 143 PSIG (985kPa). As the system test pressure was 144 PSIG (992kPa) the low side is acceptable (see step 10 below for an SI unit example).

This assumes that the system air is at the same temperature as the ambient temperature and that the test mixture of air and refrigerant is a perfect gas.

6. Isolate the low side from the high side by closing all the interconnecting valves.
7. Pressure-test the high side of the system with dry nitrogen or dry air and 1% of the system refrigerant charge to the high side pressure given in Table 6 or 80% of the setting of the pressure relief device protecting the high side.
8. If leaks are found then blow down the high side and repair any leaks, otherwise go to Step 10.
9. Again, pressure-test the high side to the high side pressure as in Step 7.
10. If no leaks are found, record the pressure and the ambient temperature and hold the high side of the system pressurized for 12 hours (overnight). Note the system pressure and the ambient temperature after 12 hours and if the pressure has not decreased by more than 0.5% of the pretest temperature-corrected pressure, the high side can be considered leak-free for refrigeration purposes.

For example, consider a high side ammonia system where the pre-test pressure was 1700kPa gauge at an ambient temperature of 27°C and test pressure reduced to 1635kPa gauge at an ambient temperature of 17°C. The pre-test pressure is corrected for the temperature variation as follows:

The minimum pressure of an acceptable leak-free system is 99.5% of P_c which is 1632kPa gauge. As the system test pressure was 1635kPa gauge, the high side is acceptable (see Step 5 above for an English unit example).

$$P_c = \frac{(17 + 273)}{(27 + 273)} \times (1700 + 101)$$

$$= 1741\text{kPag abs.}$$

$$= 1640\text{kPa gauge}$$

4.9 SYSTEM EVACUATION

The system must be evacuated to remove both air and moisture according to good refrigeration practice. Any free moisture and air in a system will mix with the refrigerant and oil to form harmful organic contaminants in resinous sludge and wax-like forms which will plug the oil filters and strainers and damage the compressor.

This evacuation can be done with a high vacuum pump capable of reducing the absolute pressure to 1000 microns (1000 $\mu\text{m} = 1\text{mm}$) of mercury or less. As the internal pressure is reduced, the temperature at which the water boils (saturation temperature) is also reduced. As the water-boiling temperature is lowered below the external ambient temperature, heat is transferred into the system and vaporizes the water which is removed by the vacuum pump. With high ambient temperatures, dehydration occurs more quickly (see Table 7).

DO NOT evacuate with oil in the separator as the oil prevents any trapped moisture from boiling off.

The following procedure is recommended:

1. Ensure all leaks have been corrected by pressure-testing as in Section 4.8.
2. Blow the system down to atmospheric pressure.
3. As many commercial vacuum pumps contain brass, which is attacked by ammonia in the presence of moisture, remove any ammonia remaining in the system from the pressure test by adding dry nitrogen to a pressure of about 10 PSIG (70kPag). Again blow the system down to atmospheric pressure.

TABLE 7
PRESSURE - BOILING TEMPERATURE RELATION FOR WATER

MICRONS (μm) OF MERCURY	ABSOLUTE PRESSURE			BOILING TEMPERATURE	
	PSI	INCHES OF MERCURY	Pa	° F	° C
100	0.00193	0.004	13.3	-40	-40
200	0.00385	0.008	26.6	-28	-33
500	0.00964	0.020	66.4	-12	-24
1000	0.0193	0.039	132.9	+1	-17
2000	0.0385	0.078	265.8	+14	-10
5000	0.0964	0.197	664	+34	+1
10000	0.193	0.393	1329	+52	+11

Section 4

INSTALLATION

4. Open all the interconnecting valves between the low and high pressure sides.
5. Install a vacuum gauge at the oil filter drain valve or some other convenient system connection. Open the drain valve.
6. Attach the vacuum pump by hose to the blowdown valve on the oil separator.
7. Open the blowdown valve.
8. Start the vacuum pump and evacuate the system to 1000 microns of mercury absolute pressure 0.0193 PSIA (133 Pa). Depending on the internal volume of the system, the amount of air and water present, the ambient temperature and the size of the vacuum pump, this may take from half an hour to ten hours. Should the ambient temperature be less than 32°F (0°C), evacuate the system to 200 microns of mercury absolute pressure 0.00385 PSIA (27Pa).
9. Close the blowdown valve.
10. Stop the vacuum pump.
11. Record the system absolute pressure.
12. Wait two hours and repeat steps 6, 7, 8, 9, 10 and 11.
13. Wait two hours and read the system absolute pressure again. If the pressure has not increased, dehydration is complete. If the pressure has increased, repeat Steps 6, 7, 8, 9, 10 and 11.
14. If the vacuum fails to hold after several dehydration attempts, check the system for leaks and again repeat Steps 6, 7, 8, 9, 10 and 11.
15. Close the blowdown valve and the vacuum gauge valve.
16. Charge the system with refrigerant at the charging valve.

Even with the above procedure, small amounts of moisture located a long way from the vacuum pump may be difficult to remove. A filter-dryer (preferably with a replaceable element) should be installed in halocarbon systems in the liquid line downstream of the charging valve to remove this residual water. The circulating refrigerant brings the residual moisture to the dryer. The filter dryer element may have to be changed several times before the correct degree of dryness (as shown by a moisture indicator installed in the liquid line downstream of the filter-dryer) is obtained.

4.10 COUPLING ALIGNMENT

The compressor is supplied leveled and secured to the package base frame with dowel pins. DO NOT loosen the bolts or disturb the compressor. Tighten the compressor mounting bolts to the torque given in Table 11 in Section 7.3, as they may have loosened in shipment.

PREPARATION FOR ALIGNMENT

1. The compressor package should be leveled and securely anchored without base distortion as in Section 4.4.
2. Have available a supply of clean shim stock in various thicknesses from 0.001 to 0.020 inch

(0.025 mm to 0.508 mm) and slotted to fit the motor mounting bolts.

3. Check to make sure the motor feet and the package mounting pads are free of dirt and burrs.
4. Remove the coupling spacer and flexible elements, if fitted, by removing the nuts, bolts, and thin and thick washers. Note the orientation of the thin and thick washers with the bevel facing the flexible elements.
5. Tie a wire through one bolt hole of each flexible element pack to retain the original orientation of each element in the pack and to ensure that each flexible element pack contains the same number of elements.
6. If the hubs are not mounted on the compressor shaft and the motor shaft, assemble the hubs as in Section 7.6.
7. Have a crowbar or other strong lever available to raise the motor for access to the shims.

PRELIMINARY ALIGNMENT

Refer to Figure 4-4. Roughly align the motor to the compressor to get within dial indicator range (so the indicator is not damaged by being displaced out of its range) and to ensure that the motor shaft is lower than the compressor shaft (so that height increases are possible with shims).

1. Move the motor so the distance between the end of the compressor shaft and the end of the motor shaft is 5 inches (127 mm) for all models built prior to November, 1981, and 4.88 inches (124mm) on packages built after November, 1981, or the dimension required for your coupling.
2. Place a straight edge across the top of the rim of one hub flange to the rim of the other. Measure the gap between the straight edge and the rim of the second coupling with feeler gauge. Add or remove shims at each corner of the motor to raise or lower the motor by the measured amount so that the gap is reduced to about 1/32 inch (1 mm).
3. In a similar manner, measure the shaft offset from side to side and jack the motor from side to side to reduce the gap to about 1/32 inch (1 mm).
4. Loosen the motor mounting bolts and check that the motor feet are level by trying to rock the motor or move the shim packs by hand. Neither will be possible when the motor feet are level.
5. Place expanding grout around the entire base channel flanges to ensure stability of the coupling alignment.

FINAL ALIGNMENT

1. Attach two dial indicators together securely to either coupling hub using a chain block or a vise clamp as in Figure 4-5. Set one plunger on the top of the face of the opposite hub close to the rim or outside diameter (to measure the angularity) and set the other plunger on the top center of the rim (to measure the concentric-

Figure 4-4 Preliminary Alignment

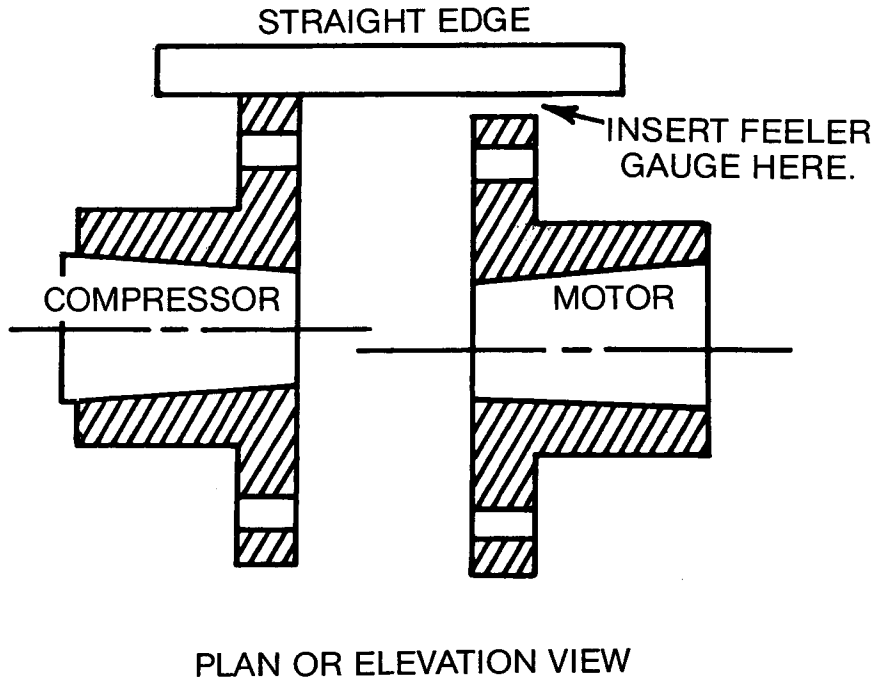

- ity). Make sure that the plunger point is on a clean unpainted surface. Position both indicators such that their plungers are approximately half depressed to allow movement of the pointer in either direction.
2. Set both dial faces to zero as in position N in Figure 4-5.
3. Make sure that the indicators are securely attached by rotating the compressor shaft and the motor shaft together 360 degrees or one complete revolution. The dial readings should return to zero. If the indicators do not return to zero check the mounting of the indicators and tighten the chain block or the vise clamps.
- 4.

⚠ WARNING

The maximum allowable coupling angularity or concentricity misalignment is 0.002 inch (0.05 mm) total indicator reading (T.I.R.). The total indicator reading is obtained by subtracting the lowest reading from the highest reading. Use care to observe the sign change when subtracting a negative reading eg: $0.003 - (-0.002) = 0.005$ and $0.003 - (+0.002) = 0.001$.

5. The adjustment for misalignment should be made in a specific sequence. The four positions of alignment described in Figure 4-7 are arranged in the recommended order.

6. The following example shows the recommended procedure for correcting coupling misalignment.
7. When making shim changes, use a small number of thick shims rather than a large number of thin shims to prevent excessive compression of the shim packs when the mounting bolts are tightened.
8. When making shim changes, change and secure one foot at a time. Tighten the bolt only enough to prevent the motor moving about while making shim changes. The next best procedure is to shim both inboard and outboard feet at the same time. This method helps to retain any correction already obtained.
9. Whenever shims are changed and the motor is moved, the mounting bolts should be tightened evenly in the sequence in Figure 4-7 to the same torque given in Table 11 in Section 7.3. This minimizes misalignment caused by the motor shifting when tightening the bolts and by the motor pads not being level.
10. Whenever shims are changed and the motor is moved and the mounting bolts are tightened, a continuing sequential record should be kept of each set of 8 indicator readings on a simple elliptical sketch as in Figure 4-5.
11. Set both dial indicators to zero (0.000 inch, 0.000 mm) in position N in Figure 4-5. Rotate both the compressor shaft and motor shaft together in 90° or quarter turn steps and record both indicator readings at each 90° step. Turn-

Section 4 INSTALLATION

Figure 4-5 Final Alignment Procedure

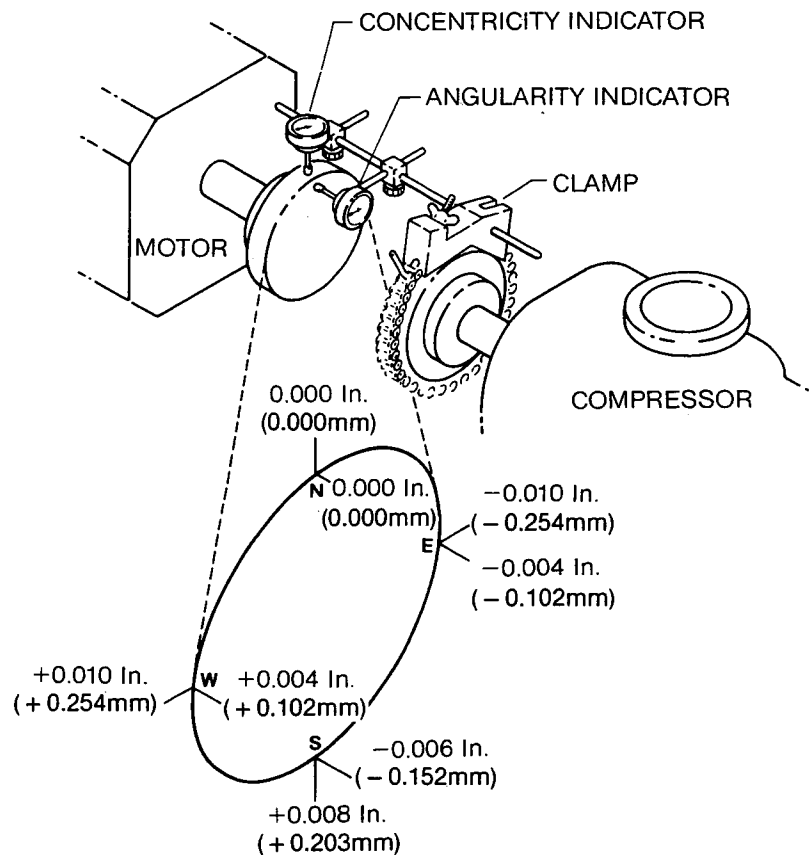

- ing both hubs together ensures that readings are recorded at the same point on each hub eliminating the effect of any irregularities on the rims or faces of the hubs. A mirror may assist in taking the readings. A sample set of readings is given in Figure 4-5.
12. Never accept a single reading. Look for repeatability by rotating both shafts together several times and check that the reading remains the same.
 13. The "angularity in elevation" misalignment from 0.000 inch (0.000 mm) at Point N to -0.006 inch (-0.152 mm) at Point S indicates that the rear of the motor is higher than the front in relation to the compressor. The T.I.R. is 0.006 inch (0.152 mm).
 14. Calculate the distance to move the motor feet as follows:
 - a. Measure the angularity indicator plunger circle diameter (a little smaller than the coupling hub diameter) (D), for example 6 inches (152 mm).
 - b. Measure the distance between the front and rear motor mounting bolts (L), for example 30 inches (762mm).
 - c. Let the angularity in elevation misalignment T.I.R. as measured in 13 above be (M).
 - d. Let the shim thickness to be added or removed be (S).
 - e. Then the shim thickness to be added or removed is calculated by dividing the bolt distance (L) by the coupling diameter (D), and multiplying the result by the misalignment (M).
 15.

$$S = \frac{LM}{D}$$

$$= \frac{30 \times 0.006}{6} = \frac{750 \times 0.152}{150}$$

$$= 0.030 \text{ inches} = 762\text{mm}$$

Remove 0.030 inch (0.76mm) of shim from the two rear motor feet. Use a crowbar or other strong lever to raise the motor for access to the shims.
 16. Tighten the mounting bolts to the torque given in Table 11 in Section 7.3.
 17. Recheck the angularity in elevation misalignment as in Steps 11 to 14 above. Record all 8 dial indicator readings. Note that the motor shaft can be above or below the compressor shaft (i.e. not concentric) and this will not affect the angularity in elevation calculation.

Section 4 INSTALLATION

Figure 4-6 Alignment Sequence

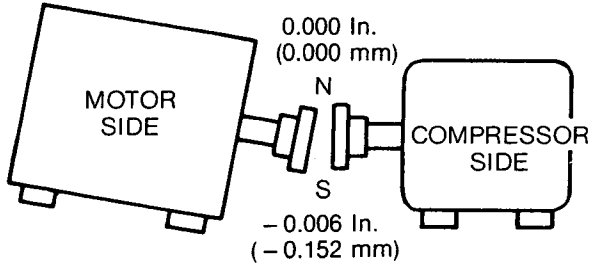

Step 1: Angularity in elevation—This alignment is adjusted with shims and is not readily lost in making the other adjustments.

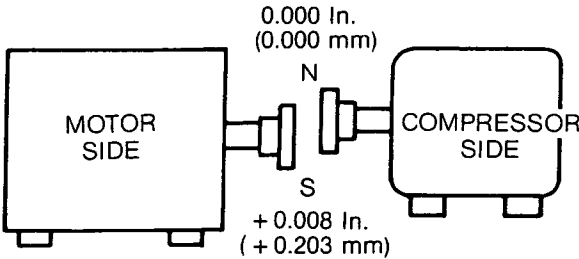

Step 2: Concentricity in elevation—This alignment is also made with shims, but it cannot be made while there is angular misalignment in elevation.

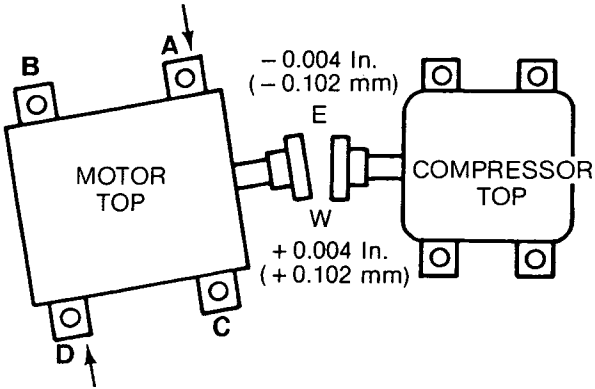

Step 3: Angularity in plan—This position can easily be lost if placed ahead of the two adjustments in elevation.

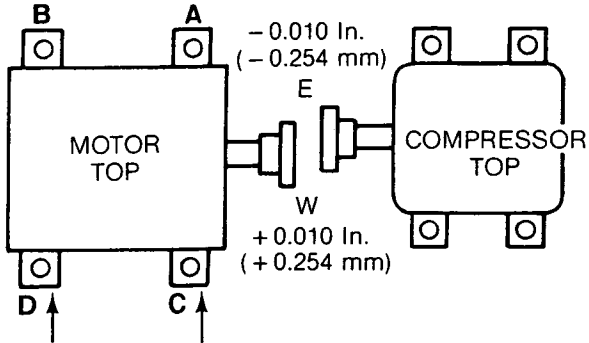

Step 4: Concentricity in plan—This adjustment cannot be made while there is still angular misalignment in plan, and can easily be lost if elevation adjustments are made.

Section 4 INSTALLATION

When this is checked, the motor shaft is parallel in elevation to the compressor shaft, completing Step 1 in Figure 4-6.

18. The "concentricity in elevation" misalignment in Figure 4-5 from 0.000 inch (0.000mm) at Point N to 0.008 inch (0.203mm) at Point S indicates that the motor is lower than the compressor. The T.I.R. is 0.008 inch (0.203mm).
19. The distance to move the motor feet is half of the concentricity in elevation misalignment T.I.R. This is 0.004 inch (0.102 mm) from 18 above.
20. Add 0.004 inch (0.102 mm) of shim to each of the four motor feet.
21. Tighten the mounting bolts to the torque given in Table 11 in Section 7.3.
22. Recheck the concentricity in elevation misalignment and record all 8 dial indicator readings. When this is checked the motor shaft is both level and parallel in elevation to the compressor shaft, completing step 2 in Figure 4-6. No more shims should need to be added or removed to the motor feet to complete the alignment.
23. The "angularity in plan" misalignment in Figure 4-6 from -0.004 inch (-0.102 mm) at Point E to 0.004 inch (0.102 mm) at Point W indicates that the motor is displaced clockwise in plan in relation to the compressor. The T.I.R. is 0.008 inch (0.203 mm).
24. Calculate the distance to move the motor feet in a similar manner to the "angularity in elevation" misalignment in Step 14, except (M) represents the "angularity in plan" misalignment T.I.R. and S is the distance the motor feet have to be moved from side to side.
- 25.

$$\begin{aligned}
 S &= \frac{LM}{D} \\
 &= \frac{30 \times 0.008}{6} = \frac{750 \times 0.203}{150} \\
 &= 0.040 \text{ inches} = 1.02 \text{ mm}
 \end{aligned}$$

Fit jack screws (supplied on most packages) to the frame at Points A and D in Figure 4-6. Bring the jack screw at Point A in contact with the motor frame and turn the jack screws at

Figure 4-7 Motor Bolts Tightening Sequence

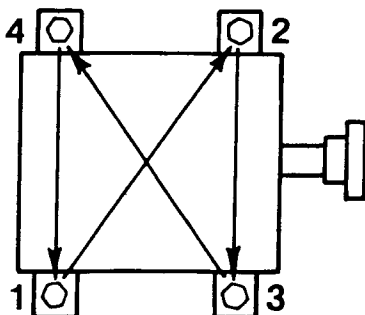

- Point D in the direction of the arrow to move the motor rear feet 0.040 inch (1.02mm) clockwise when viewed from above.
26. Tighten the motor mounting bolts to the torque given in Table 11 in Section 7.3.
27. Recheck the angularity in plan misalignment and record all 8 dial indicator readings as in Step 12 above. When this is checked the motor shaft is parallel to (in elevation and plan), and level with, the compressor shaft, completing Step 3 in Figure 4-6.
28. The "concentricity in plan" misalignment in Figure 4-6 from -0.010 inch (-0.254mm) at Point E to +0.010 inch (0.254mm) at Point W indicates that the motor is displaced in the direction of Point W. The T.I.R. is 0.020 inch (0.508mm).
29. The distance to move the motor feet is half of the concentricity in plan misalignment T.I.R. This is 0.010 inch (0.254 mm) from 28 above.
30. Fit jack screws to the frame at points C and D in Figure 4-6. Bring both jack screws into contact with the motor frame and then turn them in the direction of the arrows to move both feet 0.010 inch (0.254 mm).
31. Tighten the motor mounting bolts to the torque given in Table 11 in Section 7.3.
32. Recheck the concentricity in plan misalignment and record all 8 dial indicator readings as in Step 11 above. If necessary, readjust the motor as outlined in the preceding steps if either of the angularity or concentricity indicators exceeds the maximum allowable misalignment of 0.002 inch (0.051 mm). When this is checked, the motor shaft should be satisfactorily aligned within 0.002 inch (0.051 mm) angularity and concentricity from top to bottom (elevation) and from side to side (plan) to the compressor shaft.
33. Reverse the checking procedure by adjusting both dial indicators to zero at Point S. Again readjust the motor as in the preceding steps.
34. Check the spacing between the motor shaft and the compressor shaft to make sure there is sufficient room to accept the coupling spacer. This should be the hub spacing + 1/8 (1.6mm) per paragraph 1 of the Preliminary Alignment for all flexible disc models.
35. Finally, tighten the motor mounting bolts in the sequence in Figure 4-7 to the torque in Table 11 in Section 7.3.
36. Finally, recheck the alignment as in Step 33. If difficulty is experienced obtaining the alignment within the tolerance, proceed to Leveling the Motor Feet below, as the motor feet may not be sufficiently level.
37. Set the flange to flange spacing to the specified distance in Table 13 in Section 7.6. When setting coupling spacing on motors with sleeve bearings, it is mandatory that the motor armature be located on its magnetic center. Contact the motor manufacturer or Sullair Refrigeration Service for details.

Section 4 INSTALLATION

Figure 4-8 Angularity Alignment

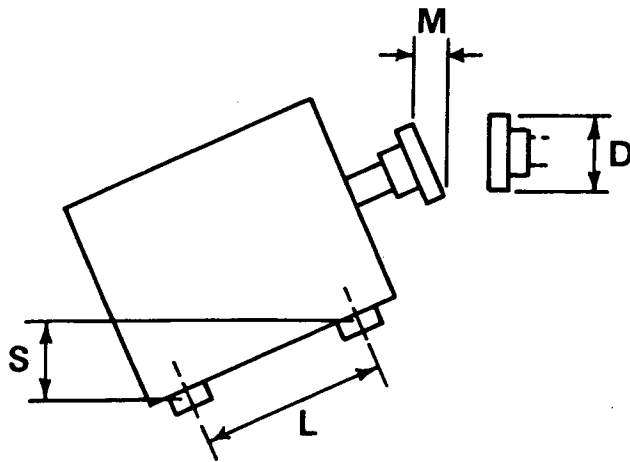

38. **DO NOT** assemble the coupling and dowel pin the motor to the frame until the alignment has been verified by a Sullair Refrigeration Representative. The Sullair Refrigeration Representative will be available to supervise these operations, but the customer must supply the dowel pins, drill reamer, drill bits and the labor.

LEVELING THE MOTOR FEET

All motor support feet must be in the same plane. If they are not level it makes exact alignment difficult. If one foot is higher, it stresses and springs the frame work and the motor or, if badly out of level, it can break the foot. Each time this foot is tightened it must be tightened to the same torque value, or a different indicator reading will result. The following procedure levels the motor feet in relation to the package base frame.

1. Tighten all mounting bolts evenly in the sequence in Figure 4-7 to the torque in Table 11 in Section 7.3.
2. Attach a dial indicator plunger on the top center of the rim (to measure the concentricity) in position "N" on Figure 4-6. Position the plunger so it is half depressed to allow movement of the pointer in either direction.
3. Set the dial face to zero.
4. Loosen one of the inboard feet and record the total movement on the indicator. Tighten the foot.
5. Loosen the adjacent inboard foot and record the total movement before tightening it.
6. If this reading is greater than the reading for the first foot, add shims to this second foot equal to the difference.
7. When the reading on the second foot is less than or equal to 0.003 inch (0.076 mm) re-

check the first foot. This will confirm that the inboard feet checked are level.

8. Repeat the procedure for the outboard pair of adjacent feet.
9. A reading on any foot less than or equal to 0.003 inch (0.076mm) when three bolts are tight and one is loose is an acceptable reading.
10. Finally, tighten the motor mounting bolts evenly in the sequence in Figure 4-7 to the torque in Table 11 in Section 7.3.

4.11 ELECTRICAL CONNECTIONS

⚠ DANGER

Lethal shock hazard inside.

Disconnect all power at source before opening or servicing.

⚠ WARNING

Use equipment grounding connector in accordance with the National Electrical Code, and all Federal, State and Local codes, to help avoid possible ground fault shock hazard.

The package is supplied with a completely wired electrical control system which requires a 115 volt, single phase, 60 hertz power supply of 500 VA capacity (2.5 KVA if auxiliary oil pump is installed) and some field connections at the terminal strip. For compressors with MCS panels, the power supply is 500 VA and a separate source of 2.0KVA must be supplied for the pump if installed. All electrical connections are to be made according to the wiring diagrams for your specific compressor. Make sure that electrical interfacing with the compressor complies with local, state and federal codes.

⚠ WARNING

Disconnect all power at source before attempting maintenance or adjustments.

Local codes may require a warning sign for automatically starting and stopping equipment.

⚠ WARNING

DO NOT supply power to the compressor control panel until oil has been charged into the oil reservoir. Failure to observe this caution will result in a burned out oil heater.

Section 4

INSTALLATION

4.12 INITIAL OIL CHARGE

▲ WARNING

Used or filtered oil should never be added to a refrigeration screw compressor under any circumstance. Use only new approved oil.

Before charging any oil into screw compressor package, see Section 3.4.

Sufficient oil should be charged into the oil separator reservoir to establish a level in the upper sight glass. See Table 4 of Section 3 for the nominal oil charge.

An additional 2 gallons (8 liters) of oil should be pumped into the filter through the valve in the bottom of the filter canister to assure adequate lubrication during the initial start-up.

Check that the bearings are prelubricated by loosening a nipple on the discharge journal bearing oil supply line at the compressor bearing and pump a small additional amount of oil until oil weeps at the loosened nipple. Make a final check by pumping further oil and noting the pressure increase on the oil pressure gauge.

See Section 3.4 for oil specifications.

4.13 INITIAL OIL WARM-UP

After installing the initial oil charge, connect the oil heater and supply power to the compressor panel before the arrival of the Sullair Refrigeration Service Representative. This will allow the oil in the oil reservoir to warm to operating temperature and will help facilitate a smooth start-up.

With power to the motor off, power supplied to the panel and the oil temperature below the thermostat setting of 105°F (41°C) verify that the oil heater is on by checking the current drawn. Alternatively check the heater element by noting the relative temperature of the separator at the element and the opposite side.

The compressor should **NEVER** be started until the oil is 68°F (20°C) or 10°F (6°C) above saturation temperature of the package pressure whichever is higher. Ideally, the temperature should be 80°F to 100°F (27°C to 38°C).

4.14 ELECTRICAL CHECK

Before attempting to start the compressor, the electrical control system, protective switches and capacity controls must be checked in a simulated operating condition. Be sure there is oil in the separator so the oil heater will not burn out. For compressors with MCS controls, the Sullair Refrigeration Service Representative will perform the electrical check. A separate manual is available for servicing the MCS.

The simplest and most reliable method of checking the electrical system is to feed the power supply to the control panel with the main drive motor power disconnected. This can be accomplished by disconnecting the motor power at the main power disconnect. If the control power is also supplied from the main disconnect, a separate temporary 115 volt, single phase, 60 hertz source should be obtained or the motor starter coil should be disconnected.

▲ CAUTION

The electrical check must be made with the main motor disconnected.

4.15 PROTECTIVE SWITCH CHECK

All switches are to be adjusted to values shown in Section 3.3.

LOW OIL PRESSURE PROTECTIVE SWITCH

With panel power on, simulate a start by pushing the START button to energize the main control relay, 4CR. After ten seconds, the time delay (1TR) will time out, de-energizing the main relay and causing the low oil pressure circuit to light up the pilot light on the control panel. This oil pressure switch is factory preset and sealed and requires no field adjustment. Tampering with this device constitutes abuse of the compressor under the terms of the warranty.

HIGH DISCHARGE PRESSURE/LOW SUCTION PRESSURE, HIGH DISCHARGE TEMPERATURE AND HIGH OIL TEMPERATURE PROTECTIVE SWITCHES

To check the remaining protective switches, jumper the low oil pressure switch, then readjust or manually manipulate each protective switch after simulating a start and note whether the main control relay 4CR drops out. Also, check that the appropriate pilot light on the panel door lights up.

ANTI-RECYCLE TIMER, MOTOR OVERLOAD AND LOAD LIMIT RELAY

Set the anti-recycle timer to the value in Section 3.3 according to the motor power. Check that the correct motor overloads are installed for the motor nameplate full load current. The load limit relay has to be set as in Section 5.10 after the compressor is running (and after the high discharge pressure switch has been set).

4.16 CAPACITY CONTROL ELECTRIC VALVE ACTUATOR CHECK FOR DC ACTUATOR

Refer to Section 7.15. With the main motor disconnected, the low oil pressure switch jumpered, and the control system energized to simulate operation, the following items should be checked.

1. Run the capacity control valve to the maximum position with the manual "Load" switch on the control panel. The capacity decal (4) on the end of the camshaft should read maximum in the vertical position (see Figure 7-20).

Section 4 INSTALLATION

2. Press the manual "Load" switch and manually trip the maximum position roller switch (8) (on the second cam away from the compressor). The shaft should rotate 1 to 1½ turns from the maximum position to the maximum position stop before the torque switch stops the motor.
 3. If there are more or less turns of the first gear and clutch assembly (20), adjust the maximum position cam as in Section 7.15 (H).
 4. Return the first gear and clutch assembly (20) to the maximum position from the maximum position stop.
 5. Mark the first gear and clutch assembly (20) with a pencil or felt pen.
 6. Check the minimum position cam (7) setting by rotating the capacity control motor (16) counterclockwise from the maximum position setting with the manual "Unload" switch on the control panel and counting the number of revolutions of the marked first gear and clutch assembly (20). Table 8 shows the correct number of revolutions of the first gear and clutch assembly (20) for the system to move the capacity control valve from the maximum to minimum position. Note the capacity decal may or may not read minimum when the number of turns is correct. The same decal is used on all models regardless of the number of turns from maximum to minimum.
 7. If there are more or less turns of the first gear and clutch assembly, adjust the minimum position cam (7) as in Section 7.15 (H).
 8. Again, run the capacity control valve to the maximum position with the manual "Load" switch.
 9. With the capacity control valve at the maximum capacity position push the red stop button and the capacity control should move to the minimum position. If it does not move to the minimum position, check the unloading wiring circuit.
 10. Check the operation of both torque switches. Run the capacity control valve in the "Load" and "Unload" directions and stop the shaft rotation with the hand crank. The motor should "torque out".
- 4.17 CAPACITY CONTROL ELECTRIC VALVE ACTUATOR CHECK FOR AC ACTUATOR**
Refer to Figure 7-19. For the AC motor driven EVA, the following steps should be followed:

⚠ WARNING

Disconnect 120V power before proceeding.

1. Remove manual hand operator knob (1) and valve actuator cover (3) (see Figure 7-19).
2. Loosen limit cams (33) located on the multi-turn gearbox assembly cam shaft. A 3/32nds Allen wrench is required.
3. Depress actuator brake solenoid (10) to release brake from brake disc (6). With an adjustable wrench manually turn the output shaft (see main gear box [17]) in a clockwise direction to the mechanical stop of the ball screw assembly. Upon reaching full maximum capacity position (mechanical stop) a slight bind will be felt. **DO NOT OVERTORQUE OR DAMAGE TO THE BALL SCREW ASSEMBLY WILL RESULT.**
4. Rotate the output shaft one full revolution counterclockwise and set the maximum position cam (limit switch actuated) (33). Mark the output shaft with a felt-tip pen. The maximum cam and limit switch are located closest to the actuator base (17) with the red wire.
5. Table 8 depicts the number of turns from maximum position to minimum based on the compressor model and built-in volume ratio. To determine your compressor model and built-in volume ratio, refer to the nameplate on the compressor control panel.

TABLE 8

REVOLUTIONS OF MAIN OUTPUT SHAFT OR FIRST GEAR AND CLUTCH ASSEMBLY TO MOVE THE CAPACITY CONTROL VALVE FROM MAXIMUM TO MINIMUM

COMPRESSOR MODEL	2.2, 2.6 & 3.7 BUILT-IN VOLUME RATIO (I)	4.8 BUILT-IN VOLUME RATIO (I)
C16L	25	18
C20S	19	14
C20L	30	23
C25S	25	18
C25M	25	18
C25L	38	29
C40L	54	40

(I) Volume ratio is given in the model number for each package, shown on the nameplate on the door of the control panel.

Section 4

INSTALLATION

6. Again, manually depress the actuator brake solenoid (10) and rotate the output shaft counterclockwise (unload) per the correct number of revolutions per Table 8 with respect to the mark placed on the output shaft in Step 4.
7. When the correct number of turns is met, set the minimum position cam (33) and limit switch (41) (limit switch actuated).
8. Loosen the turn indicator (30) and set to zero minimum capacity position and tighten indicator.

4.18 MOTOR ROTATION CHECK

Remove the coupling spacer if fitted.

Supply power to the motor starter and rotate the START button to the "Auto/Start" position. Bump the motor by pushing the START button then pushing the STOP button. Verify the motor rotation by observing the coupling.

⚠ WARNING

The motor shaft will rotate counterclockwise when facing the motor shaft end when motor rotation is correct.

If the motor rotates in the wrong direction, disconnect the power supply to the starter at the circuit breaker and reverse two of the three phases by

interchanging two of the three electrical lines at the starter or at the motor terminal box.

⚠ WARNING

DO NOT run the compressor in the reverse direction more than a few seconds. Failure to observe this caution could result in serious damage to the compressor.

Rotate the starting switch to the "Manual/Reset" position. Disconnect power from the motor starter.

4.19 MOTOR LUBRICATION

Lubricate the motor to the instructions given in the motor manual supplied with the motor. The following lubricating instructions apply only to standard ball or roller bearing grease lubricated motors. **DO NOT** overgrease.

1. Clean the exterior of the motor.
2. Remove both the grease plug and the relief plug (if supplied).
3. If the grease has hardened, run a wire a short distance into the grease to break it up.
4. Regrease the motor with the grease shown on the motor nameplate or specified in the motor manual. Use a low pressure grease gun.
5. The bearing chamber should not be more than three quarters full.
6. Run the motor for ten minutes.
7. Replace the grease plugs and relief plugs.

Section 5 OPERATION

5.1 START-UP

After all the installation functions covered in Section 4 have been completed, it will be possible for the Sullair Refrigeration Service Representative to perform start-up service. The Sullair Refrigeration Service Department should be notified a minimum of two weeks before a scheduled start-up to assure timely arrival of the Sullair Refrigeration Service Representative. It is necessary that key operating personnel be available to go through the start-up, since a great deal of knowledge can be obtained in this manner. The operations covered in this section will be performed at start-up under the supervision of a Sullair Refrigeration Service Representative.

NOTE

See Section 4.2 before scheduling the start-up.

5.2 COUPLING ALIGNMENT VERIFICATION

The Sullair Refrigeration Representative will verify that the coupling alignment has been achieved within the limits prescribed in section 4.10. When alignment has been verified, it will be necessary for those with installation responsibility to dowel pin the motor, assemble the coupling spacer and mount the coupling guard. See Sections 4.10 and 7.7 for coupling instructions. The Sullair Refrigeration Representative will be available to supervise these operations, but the customer must supply the dowel pins, drill, reamer, drill bits and the labor.

5.3 PRE-START CHECK LIST

The following section covers only the initial start of the compressor and not the remainder of the refrigeration system. Be sure that all necessary system valves are open and that the refrigeration system is ready for start-up. Use the following check list to guarantee that no items of importance regarding the compressor package have been overlooked.

1. Motor starter breaker disconnected from the electric supply line.
2. Low oil pressure protective switch reconnected.
3. Protective switches set to values in Section 3.3.
4. All protective switches verified for correct operation.
5. Oil temperature in the separator sump is 68°F (20°C) or 10°F (6°C) above the saturation temperature of the package pressure, whichever is higher, ideally 80°F to 100°F (27°C to 38°C).
6. Oil level established in upper sight glass.
7. Two gallons (8 liters) of oil pumped into filter to prelubricate the compressor bearings.
8. Cooling water to oil cooler turned on if water-cooled.

9. Liquid refrigerant supply to compressor turned on if refrigerant-cooled.
10. Stop valves to the pressure gauges are open.
11. Suction and discharge valves open.
12. Timer 3TR removed from socket.
13. Direction of motor rotation checked.
14. Motor bearings lubricated per manufacturer's specification.
15. Capacity control actuator indicator at minimum.
16. Capacity control selection switch not in "auto".
17. The "Auto-Start/Manual-Reset" selector switch in the "Manual/Reset" position.

When the above items are verified, the compressor is ready for the initial start.

5.4 INITIAL START-UP PROCEDURE

NOTE

The compressor shaft rotates clockwise when facing the compressor shaft end when the motor rotation is correct. DO NOT run the compressor in the reverse direction for more than a few seconds. Failure to observe this caution could result in serious damage to the compressor.

Connect the starter to the electric supply line at the main breaker. With one hand over the stop button and someone standing by the main breaker (in case the starter contacts fail to disengage), energize the protective circuit by rotating the start switch to the "Auto-Start" position and pushing the button. The compressor will start automatically provided the suction pressure is above the "cut in" pressure on the unadjusted "Start-Stop" pressure switch (HSP). After starting, rotate this switch to the "Manual-Reset" position so the compressor will not automatically stop and start. If the suction pressure is below the "cut in" pressure, start the compressor by rotating the start switch to the "Manual-Reset" position. Check rotation direction, oil pressure and noise and vibration and if any of these items are abnormal, immediately stop the compressor.

NOTE

The actual oil pressure is the pressure difference between the oil pressure gauge and the discharge pressure gauge.

If the oil pressure does not increase to more than 25 PSID (173kPa) within 10 seconds, the low oil pressure protective switch will stop the compressor. Check if the oil pressure relief line around the oil pump is warm indicating that the oil pressure relief valve is set too low and relieving too much oil. After any protective device stops the compressor, the failed protective switch must be

Section 5 OPERATION

manually reset at the switch and the protective switch circuit must be reset by rotating the start switch to the "Manual/Reset" position and pushing the button. Restart the compressor and run in manual start/stop as before. If the compressor again stops, loosen the locknut on the oil pressure relief valve (and/or the oil pressure regulating valve) and screw in the adjustment screw about five turns. Restart the compressor and if it again stops because of low oil pressure, clean the oil strainers and pump (if no auxiliary pump) one gallon (4 liters) of oil into the oil filter to prelubricate the compressor bearings. Restart the compressor and if it again stops because of low oil pressure, check the low oil pressure (Troubleshooting Section 6.7 under "Low Oil Pressure").

WARNING

DO NOT restart more than two times after stopping each time because of low oil pressure without pumping one gallon (4 liters) of oil into the oil filter to prelubricate the compressor bearings.

If the oil pressure gauge exceeds the discharge pressure gauge by 100 PSI (689kPa) or more, loosen the locknut on the oil pressure relief valve (and/or the oil pressure regulating valve) and back out the adjustment screw to relieve the excessive oil pressure to approximately 75 PSI (517kPa).

On liquid injection cooled compressors, the oil temperature adjustment (see Section 5.6) should be made during initial start-up. Water-cooled and thermosiphon compressors' adjustments can be made after compressor is loaded to maximum capacity as long as temperatures do not exceed maximum setpoints listed in Section 3.3.

Restart the compressor and run for five minutes in the minimum load position. Watch all the gauges: The suction pressure slowly falls (if the load is not too great), the discharge pressure slowly rises, the discharge temperature slowly rises and the oil temperature slowly rises. The actual oil pressure at the oil manifold (oil pressure gauge reading minus the discharge pressure reading) slowly falls as the oil temperature increases.

The oil filter pressure drop can be found by subtracting the manifold oil pressure from the filter inlet oil pressure. Both the oil pressure after oil filter (at the oil manifold), and the oil pressure before the oil filter (at the oil filter inlet) are read on the "Oil Pressure" gauge. The latter is obtained by pushing the button (or turning the 3-way valve on some models) below the oil pressure gauge. The oil filter pressure drop should be carefully watched for excessive build up during the first few hours of operation. Change the filter element if the pressure drop exceeds 30 PSI (207kPa).

Continue to run the compressor and slowly load the compressor by pressing the "Load" button in the capacity control switch intermittently. When the oil reaches its minimum operating temperature of 105°F (41°C), adjust the oil pressure relief and regulating valves as described under Oil Pressure Adjustment below. Stabilize the oil temperature by adjusting the controls as described under Oil Temperature Adjustment below. After the oil temperature has remained within the operating limits for fifteen minutes, make a final adjustment to the oil pressure if required.

5.5 OIL PRESSURE ADJUSTMENT

Before adjusting the oil pressure relief valve and the oil pressure regulating valve, make certain that the oil strainers are clean and oil temperature is at its normal operating temperature of 105°F to 115°F (41°C to 46°C) for water-cooled and thermosiphon-cooled or 118°F to 122°F (48°C to 50°C) for liquid injection-cooled.

1. Loosen the locknut on the relief valve and screw in the adjustment screw with an Allen wrench as far as it will go.
2. Loosen the locknut on the oil pressure regulator and screw in the adjustment screw with an Allen wrench until the oil pressure is 75 PSI (517kPa) above the discharge pressure.
3. Back out the adjustment screw on the oil pressure relief valve, while watching the oil pressure gauge, until the oil pressure begins to drop. This indicates the valve is starting to relieve and bypass oil at 75 PSI (517kPa). Tighten the locknut.
4. Back out the adjustment screw on the oil pressure regulator, while watching the oil pressure and discharge pressure gauges, until the oil pressure drops to 45 PSI to 50 PSI (310kPa to 345kPa) above discharge pressure. Tighten the locknut.

5.6 OIL TEMPERATURE ADJUSTMENT

WATER-COOLED COMPRESSORS

The normal operating oil temperature of 110°F (43°C) must be achieved by adjusting the water regulating valve. For Penn water valves, turn the spindle counterclockwise when viewed from above to increase spring loading on the diaphragm and increase the temperature. Allow a few minutes after each water valve adjustment to allow the oil temperature to stabilize. Note that the final temperature at stable operating conditions can be 105°F to 115°F (41°C to 46°C).

LIQUID INJECTION-COOLED COMPRESSORS

Refrigerant injection-cooled compressors require adjustment of both the low discharge temperature control switch (LDT) (controlling the refrigerant liquid feed solenoid valve) and the refrigerant regulating valve. Below the low discharge temperature of 105°F (41°C), the liquid solenoid valve is closed or de-energized and no refrigerant enters the compressor. When the low discharge temperature is exceeded, the solenoid

Section 5

OPERATION

valve opens and feeds liquid refrigerant to the refrigerant regulating valve. This regulating valve senses the oil temperature in the discharge pipe and varies the flow of refrigerant injected into the compressor discharge to maintain a constant discharge temperature of 118°F to 122°F (48°C to 50°C) or 10°F (6°C) above condensing temperature.

The low discharge temperature switch (LDT) also prevents refrigerant overfeed by sensing the low discharge temperature caused by cold oil at start-up or the unevaporated overfed liquid and immediately closes the solenoid valve which shuts off the supply of liquid refrigerant.

On early packages, a small bypass solenoid valve was installed. This valve was wired to open and close with the main liquid solenoid valve and with the unloading signal. This valve is no longer used and can be left in or removed from the piping and controls.

Adjustment of the low discharge temperature switch (LDT) is accomplished by adjusting the low temperature switch located in the control panel to 105°F (41°C). This switch is set by observing the discharge temperature gauge and setting the switch to open the solenoid as the temperature rises above 105°F (41°C) or as listed in Section 3.3.

The discharge temperature is sensed in the discharge line by a thermistor which acts through an electronic controller to control the liquid solenoid valve and bypass solenoid. Above 105°F (41°C), the controller opens both the main liquid solenoid valve and the bypass solenoid valve (if supplied on older units).

Adjustment of the low discharge temperature switch (LDT) involves turning the spindle on the electronic card in the control panel almost fully counterclockwise. The range of the matched thermistor and controller is 100°F (38°C), in the full counterclockwise position, to 375°F (191°C) in the full clockwise position.

The discharge temperature is sensed in the discharge line by the bulb of the self-contained refrigerant regulating valve. As the discharge temperature increases, a portion of the liquid in the sensing bulb is vaporized which increases the pressure on both the diaphragm and the adjustment spring to open the regulating valve and admit more refrigerant.

NOTE

The bulb of the refrigerant regulating valve should be coated with aluminum paste or heat transfer grease to improve heat transfer and must be installed with the "top" marking on the bulb in the up position.

Adjustment of the refrigerant regulating valve involves turning the adjusting wheel (see Figure 7-18 [5Y]) on the valve with the key supplied with the valve. Each quarter turn on the valve will cause a change in the valve control point temperature of approximately 1°F (0.6°C). The adjusting spring acts to close the valve.

Turning the collar counterclockwise when viewed from above, increases the temperature setpoint.

The recommended setting procedure for the liquid injection system is as follows:

1. Start the compressor and leave in manual capacity control and in minimum position (pull 3TR timer).
2. Close the hand globe valve (in the liquid line adjacent to the liquid injection port) and crack it open a quarter turn.
3. Turn the regulating valve adjusting wheel fully down (clockwise) to the jam nut (see Figure 7-18 [4Y]) so that the valve is wide open.
4. When the discharge temperature gauge (on the oil separator) is reading 104°F to 105°F (40°C to 41°C), adjust the low discharge temperature switch (in the control panel) to open the liquid feed solenoid valve.
5. Open the globe valve very slowly and regulate to obtain 120°F (49°C) so that expansion occurs at the globe valve. Allow time for temperatures to stabilize after each adjustment. Note that changes in suction or discharge pressure will vary the heat of compression and the discharge temperature.
6. Adjust the regulating valve adjusting wheel up (counterclockwise) again allowing for temperatures to stabilize until the discharge temperature rises above 120°F (49°C). When this occurs, the expansion is occurring at the regulating valve rather than the globe valve. Stabilize the discharge temperature at 118°F to 122°F (48°C to 50°C) or 10°F (6°C) above condensing temperature whichever is higher.
7. Open the globe valve fully so that the regulating valve takes full control. This must be done very slowly.

After the adjustments are made, check to see that the discharge temperature is being controlled by the refrigerant regulating valve and not by the low temperature switch. This condition will occur if the refrigerant regulating valve setpoint is lower than specified or if the low temperature switch (LDT) is set too high. Once the operation is verified and the compressor is allowed to operate for twenty to thirty minutes, a slight readjustment may be necessary. A further check should be made when the compressor is running at full load. The discharge temperature should always be more than 10°F (6°C) above the condensing temperature. Note that the final discharge temperature at stable operating conditions can be 118°F to 122°F (48°C to 50°C) or 10°F (6°C) above the condensing temperature, whichever is higher.

Section 5 OPERATION

During a start, the discharge temperature will rise near to the limits before the refrigerant regulating valve will respond. This is normal and should occur only on start-up.

THERMOSIPHON COMPRESSORS

Before starting the compressor, make sure that there is a good supply of liquid refrigerant to the tube side of the cooler. When the compressor is started, the oil will completely bypass the oil cooler through the 3-way temperature control valve until the oil temperature approaches the setpoint of the valve.

The valve will gradually open, mixing hot oil from the separator with cold oil from the oil cooler. There are no adjustments to be made at start-up.

5.7 PRESSURE BASED ON/OFF CAPACITY CONTROLLER ADJUSTMENT

After satisfactory adjustment of the refrigeration system has been established with manual control, the automatic capacity control pressure controller, P1/P2 can be adjusted.

A. SINGLE ADJUSTMENT CONTROLLER

The P1/P2 pressure controller consists of a single adjustment, dual pressure switch assembly with a factory set dead band of approximately 2 PSIG (14kPa). The dead band is satisfactory for the majority of refrigeration systems.

To set the controller to the desired system suction pressure carry out the procedure in Steps 1 to 8 below.

1. Utilize the test switch in the control panel to connect the load/unload pilot lights to the pressure switch (P1/P2) and to bypass the on/off timer (3TR) so that the capacity control actuator cannot operate automatically.
2. To set the controller to the desired system control pressure, place the capacity control in the manual mode.
3. With the manual load/unload switch, vary the compressor capacity until the desired suction pressure is obtained. In some systems, it may be necessary to throttle the suction valve to achieve the desired pressure.
4. When the desired suction pressure is reached and remains stable, adjust the P1/P2 controller by turning the central adjustment screw in the appropriate direction so that neither the loading nor unloading lights are on. If the load light is on, turn the adjustment screw clockwise (from above). If the unload light is on, turn the adjustment screw counterclockwise (from above).
5. To widen the dead band, lower the low pressure switch P1 (turn the adjusting threaded insert counterclockwise from above) and raise the high pressure switch P2 (turn the adjusting threaded insert clockwise from above). Widen the band evenly about the control point by making equal adjustments to both P1 and P2.

Conversely, the band can be narrowed by raising the low pressure switch P1 and lowering the high pressure switch P2.

6. Return the test switch to its original position so the pilot lights indicate when the capacity controller is loading or unloading.
7. Place the compressor in the automatic capacity control mode. It will then modulate capacity as required to maintain the desired control suction pressure.
8. Finish adjustment by setting 3TR as in Section 5.7(C).

B. DUAL ADJUSTMENT CONTROLLER

Some models were supplied with P1/P2 dual adjustment dual pressure switches without a factory set dead band. The two switches P1 and P2 can be individually adjusted as in Steps 1 to 13 below.

1. Utilize the test switch in the control panel to connect the load/unload pilot lights to the pressure switch (P1/P2) and to bypass the on/off timer (3TR), so that the capacity control actuator cannot operate automatically.
2. To set the controller to the desired system control pressure, place the capacity control in the manual mode.
3. With the manual load/unload switch, vary the compressor capacity until the desired suction pressure is obtained. In some systems, it may be necessary to throttle the suction valve to achieve the desired pressure.
4. Turn the low pressure switch P1 adjusting screw several turns counterclockwise (from above) so that the micro switch lowers toward its actuator pin. This ensures that the setting is well below the desired low pressure setpoint as shown in Figure 5-1.
5. Turn the high pressure switch P2 adjusting screw several turns clockwise (from above) so that the micro switch rises above its actuator pin. This ensures that the setting is well above

Figure 5-1 Suction Pressure and Capacity Adjustment Steps

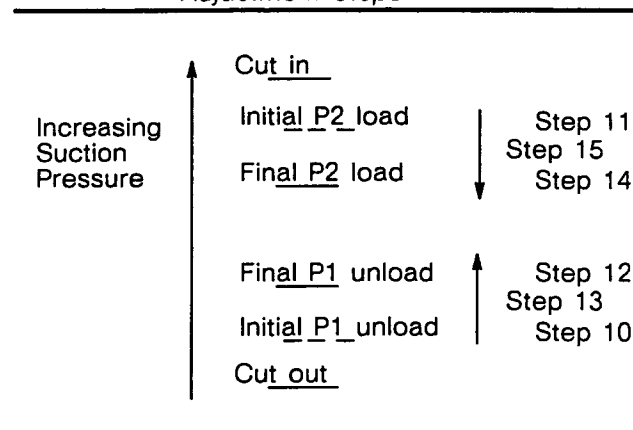

Section 5 OPERATION

the desired high pressure set point as shown in Figure 5-1.

6. Manually load the compressor until the desired low pressure setpoint is indicated on the suction pressure gauge. In some cases, the suction stop valve may have to be throttled to achieve the desired pressure. In this condition, the load pilot light should be off and the unload pilot light should be on.
7. When the pressure is stable at the low pressure point where it is desired to have the compressor unload, P1 may be adjusted by turning the P1 adjustment screw slowly clockwise until the unload pilot light goes off. P1 is now correctly adjusted.
8. Manually unload the compressor until the desired high pressure set point is indicated on the suction pressure gauge. In this condition, the load pilot light should be on and the unload pilot light should be off.
9. When the pressure is stable at the high pressure point where it is desired to have the compressor load, P2 may be adjusted by turning the P2 adjustment screw slowly counterclockwise until the load pilot light goes off. P2 is now correctly adjusted.
- 10.

NOTE

There must be a minimum pressure difference of approximately 2 PSIG (14kPa) between the settings of P1 and P2.

11. Return the test switch to its original position so the pilot lights indicate when the capacity controller is loading or unloading.
12. Place the compressor in the automatic capacity control mode. It will then modulate capacity as required to maintain the desired control suction pressure.
13. Finish adjustment by setting 3TR as in section Dual Cycle Timer (3TR) Adjustment below.

C. DUAL CYCLE TIMER (3TR) ADJUSTMENT

The response time of the capacity control system is adjusted by the settings on the dual recycling timer, 3TR.

The red center knob controls the "on" time, adjustable from 0.6 to 30 seconds, and the black outer knob controls the "off" time, adjustable from 1.2 to 120 seconds. Both increase time when turned clockwise. For adjustment, turn the black control fully clockwise and the red fully counterclockwise. Turn the red knob clockwise until the actuator moves a desirable distance. The longer the "on" time, the further the actuator will move (i.e. the increment or percentage load change at each movement will increase). The actuator moves in a stepwise fashion. The longer the "on" time, the greater percentage change per step. Turn the black knob counterclockwise

until the desired time from full load to minimum is achieved after several steps. The "off" time determines the number of steps in a given amount of time.

Experience has shown that on large refrigeration systems, the smoothest operation and the best control is achieved with slow compressor response (e.g. a short "on" time of one to two seconds and long "off" time of 120 seconds). Also, the best way to speed up the response is to slightly shorten the "off" time rather than increase the "on" time.

5.8 OPTIONAL PRESSURE BASED PROPORTIONAL CAPACITY CONTROLLER ADJUSTMENT

After satisfactory adjustment of the compressor has been established with manual control, the automatic capacity control pressure proportional controller can be adjusted.

The proportional capacity control system consists of a pressure transducer (and its power supply) which converts the suction pressure signal into an electrical signal and a solid state electronic controller, which processes this signal and initiates corrective action based upon the difference between the desired suction pressure and the actual suction pressure (pressure error). The magnitude of the control action is proportional to the magnitude of this pressure error: the greater the pressure error, the longer time the controller remains on and the further the capacity control valve moves. This is shown in Figure 5-2.

Referring to Figure 5-3, the setting procedure for the pressure-based proportional capacity controller is as follows:

1. Check connections between components and see that they are according to the wiring diagram.
2. Disconnect one of the 10V D.C. power supply leads going to the transducer.
3. Disconnect the pressure transducer from the system suction pressure and vent it to atmosphere so it senses 15 PSIA (103kPa).
4. Push down on the tab (1) to release the latch handle (2). Use the thumb spaces under the handle to pull the handle forward and up. The controller is moved forward by cams in the latch handle. Remove the controller from its housing.
5. Examine the left hand circuit board and make sure the red jumper is connected to Point D and not Point C. This increases the sensitivity and makes it much easier to find the zero output point indicated by neither the green loading light (7) nor the amber unloading light (6) coming on (DO NOT confuse these circuit board points with the Terminals C and D on the rear of the controller).
6. Turn the "Spread" control (on the front of the control under the metal cover plate [3]) with a screwdriver to full clockwise. This reduces the deadband to near zero.

Section 5 OPERATION

Figure 5-2 Proportional Capacity Control

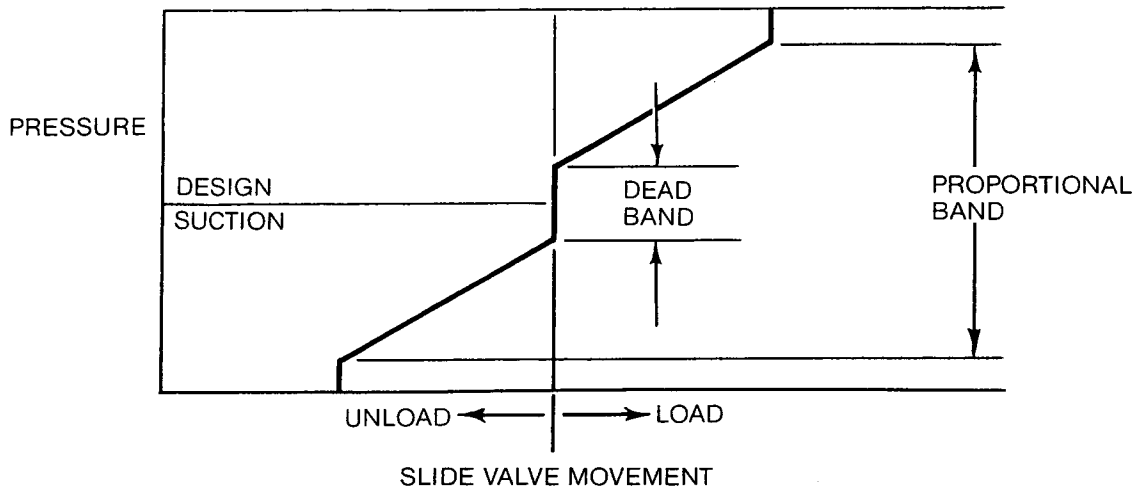
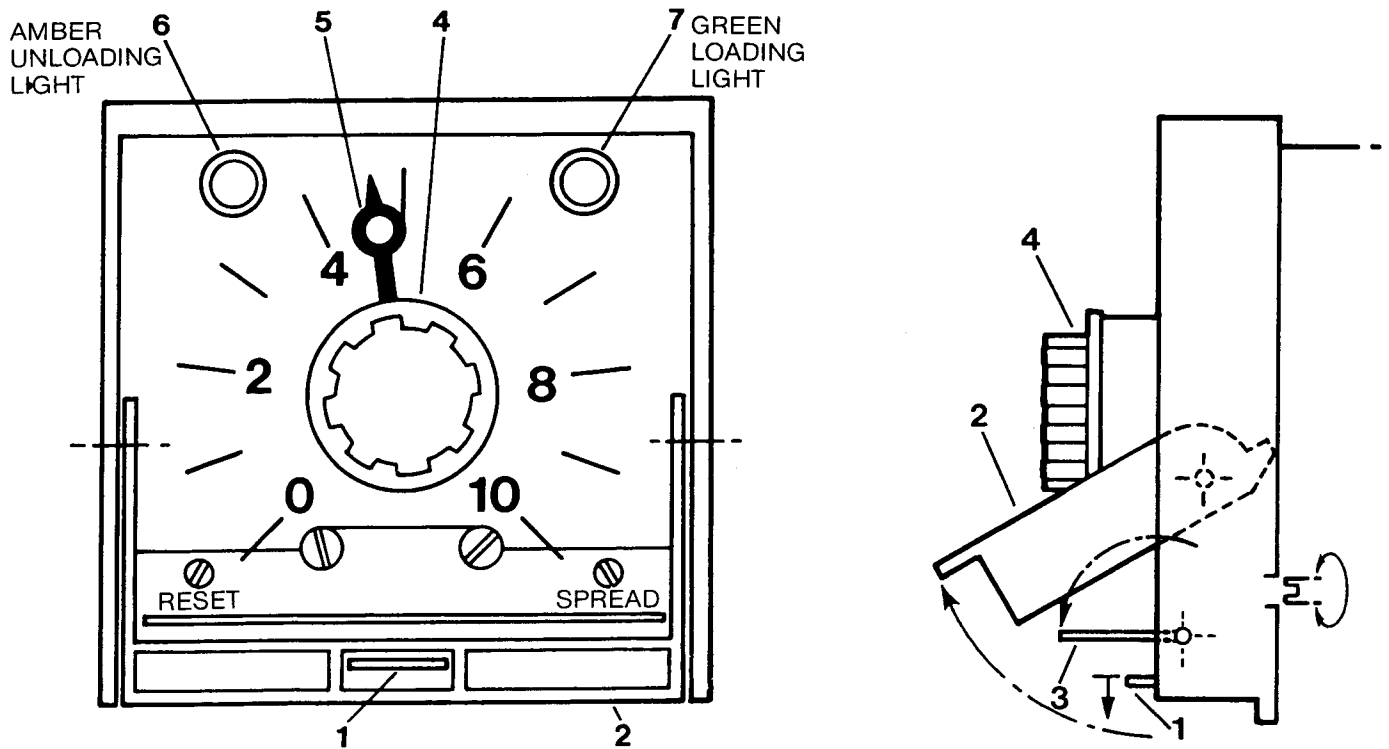

Figure 5-3 Pressure Proportional Capacity Controller



Section 5 OPERATION

7. Pull the "Setpoint" knob (4) and turn it to 0.
8. Energize the controller and adjust the "Reset" control (on the front of the control under the metal cover plate [3]) with a screwdriver so that neither the green loading light nor the amber unloading light comes on. Since the cycle time is 15 seconds, wait at least that long to make sure neither the loading nor unloading light is going to come on.
9. Reconnect the 10V D.C. power supply to the pressure transducer. The amber unloading light should come on continuously.
10. Pull the "Setpoint" knob (4) and turn it to 1.47. The 0 to 10 scale represents 0 to 100 PSIA so 1.47 represents 14.7 PSIA.
11. Adjust the power supply output voltage with a screwdriver until again neither the loading nor unloading light comes on.
12. Reconnect the pressure transducer to the system suction pressure.
13. Adjust the "Spread" control screw to achieve whatever deadband is required.

The system should need no further adjustments. The controller will now proportion the capacity control slide valve from a small movement to a large movement over a proportional band of about ± 3 PSIG (± 21 kPa) from the suction pressure control set point. If this is too tight a proportional band, it can be increased to ± 10 PSI (± 69 kPa) by moving the red jumper from Point C to point D.

Remember when setting the control point that the scale is PSI absolute times 10. So, for a control point of 20 PSI (138kPa), the setting would be $(20 + 14.7)/10 = 3.47$ or for a control point of 200 kPa, the setting would be $(200 + 101)/(10 \times 6.895) = 4.37$.

For servicing of the controller, refer to specific supplemental instructions available from Sullair Refrigeration Service.

5.9 AUTOMATIC START/STOP PRESSURE SWITCH ADJUSTMENT (HSP)

After stable automatic capacity control is achieved, the automatic "Start/Stop" switch or high suction pressure switch (HSP) may be adjusted to allow automatic starting and stopping of the compressor at set "cut-in" and "cut-out" pressures.

Set the "cut-in" pressure adjustment to the pressure where it is desired to have the compressor automatically start. This pressure may be set above the pressure at which the capacity control calls for loading, usually 2 PSI to 5 PSI (14kPa to 34kPa) above P2 setting.

Set the "cut-out" pressure adjustment at the pressure where it is desired to have the compressor automatically stop. This pressure should be set sufficiently below the pressure at which the

capacity control calls for unloading, usually 5 PSI to 15 PSI (34kPa to 103kPa) below P1 setting. If short cycling or frequent starts and stops occur at low conditions, this "cut-out" setting may have to be lowered.

Rotate the start switch to the "Auto/Start" position so that the compressor starts and stops automatically.

5.10 LOAD LIMIT RELAY ADJUSTMENT

Make sure that the high discharge pressure switch is set before adjusting the load limit relay.

The transformed current which activates the relay can be calculated by dividing full load current by the turns ratio of the current transformer. Set the load limit relay scale to this transformer current.

Artificially impose a high load on the motor until the motor ammeter indicates full load motor nameplate current by turning off condenser fans and water pumps one at a time. **DO NOT** throttle the discharge stop valve. Adjust the setting on the load limit relay until the unloading pilot light comes on. Check that the load limit relay at full motor load unloads the compressor until the excessive motor current is eliminated.

Set the 0 to 3 minute adjustable timer, 4TR, to approximately 3 minutes by turning the little white wheel to the maximum time position and then backing it off two full turns. This timer prevents the compressor loading until the time setting has elapsed. **DO NOT** leave the timer in the maximum position as this effectively prevents the timer from timing out. After July, 1987, the Allen Bradley timer was replaced by an Idec timer. This is a 0 to 100 second timer. Set the dial to maximum position. This timer will time out when set at maximum position. An amber load limiting light shows whenever an increase load signal cannot be satisfied due to the load limiting timer.

5.11 OPTIONAL DUAL OIL FILTER

Refer to Figures 5-4 and 5-5. In 1983, Sullair changed suppliers of dual filters. Changing of the filter element, or cartridge, is dependent on the type of filter installed on the package.

The newer dual filter is shown in Figure 5-4. It is a self-contained unit with an internal valve to provide uninterrupted oil flow.

Provided the ambient temperature is below the normal oil temperature, the operating oil filter is warmer to the touch than the standby filter.

To direct the flow from the operating filter to the standby filter, press the valve handle lock and turn the filter handle 180° clockwise or counter-clockwise. The filter handle will snap into position in front of the filter being used.

The standby filter element may be replaced (as in Section 7.4) with the compressor running.

Section 5 OPERATION

Figure 5-4 Dual Oil Filter – New Style

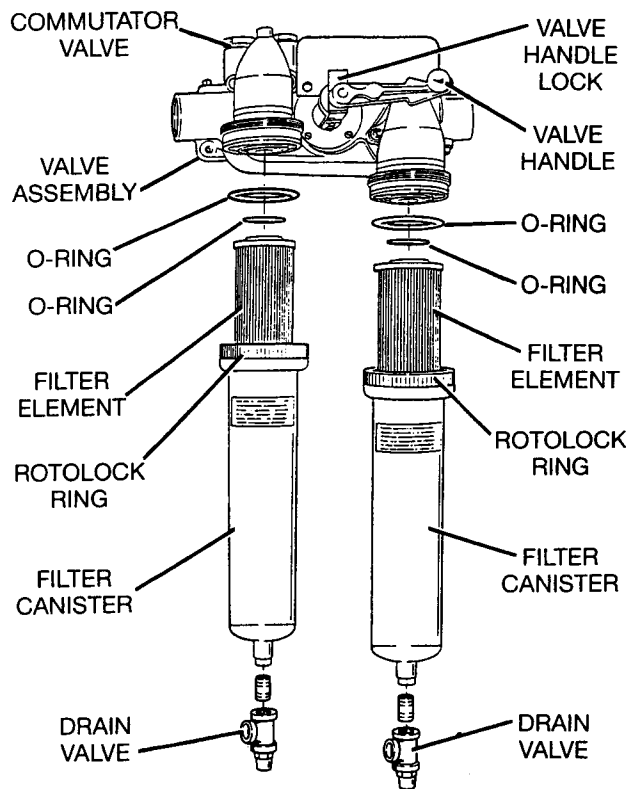
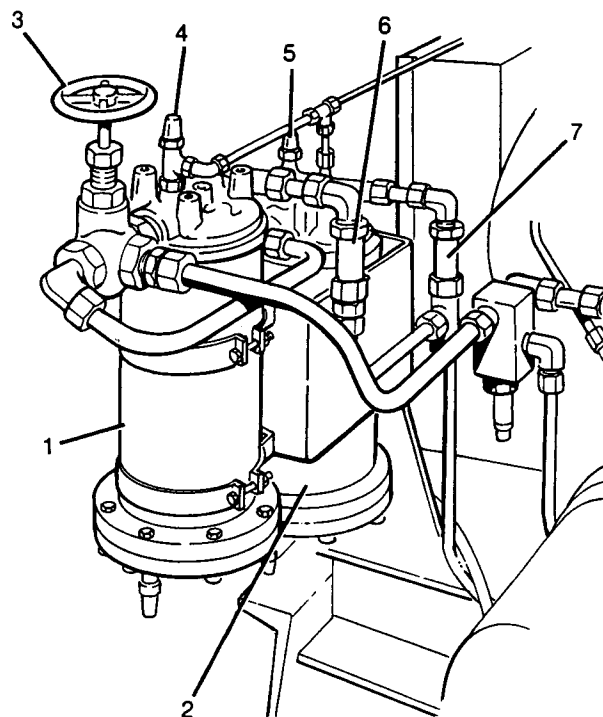

Figure 5-5 Dual Oil Filter – Old Style



The older style dual filter arrangement is shown in Figure 5-5 and consists of 2 (two) single unit (1&2) with a 3-way valve (3) to provide uninterrupted oil flow.

Provided the ambient temperature is below the normal oil temperature, the operating oil filter is warmer to the touch than the standby filter.

To direct the flow from the operating filter to the standby filter, turn the 3-way valve handle (3) slowly fully clockwise or fully counterclockwise.

Close the valve (4 or 5) to the oil pressure gauge and open the other valve (4 or 5).

The standby filter cartridge may be replaced (as in Section 7.4) with the compressor running provided the check valves (6&7) are in good condition.

See Section 7.4 (Oil Filter Element or Cartridge Replacement).

5.12 OPTIONAL DUAL OIL STRAINER

Refer to Figures 7-12 and 7-13. The optional dual strainer consists of two strainers in an integral unit interconnected by an internal 3-way valve to provide uninterrupted oil flow. The normal flow of oil is through the intake port, then through the upper port of the valve, through the inside of the strainer where all extraneous matter is trapped, through the bottom port of the valve and finally through the discharge port of the unit. To direct the flow from one strainer to the other, swing the valve handle to either of its extreme positions. The strainer in use is shown by the indicator which is cast as an integral part of the handle and which partially covers the strainer in use. The opposite chamber can then be opened and the strainer removed for cleaning. It is not necessary to drain the strainer chamber in order to remove the basket.

The dual strainers have tapered valve plugs which are adjusted at the factory. In operation, one side of the valve is exposed to the pressure developed on the chamber in use and the other side is exposed to a lower pressure. With the valve prop-

Section 5 OPERATION

erly adjusted, there will be little, if any, equalization of pressure through the valve, and consequently, the pressure on one side will tend to press the tapered plug against the low pressure side. If the pressure is great enough, this pressure causes the valve to operate stiffly. To remedy this condition, a bypass line and stop valve are provided.

When it is desired to shift operation from one strainer to the other, open the valve in the bypass line so that the pressure in both chambers is equalized. Then swing the valve with the handle toward the strainer to be put in operation. The handle will move easily when the pressure is equalized.

▲ WARNING

NEVER try to force the valve plug assembly through its cycle of operation. It should always move freely without extra leverage in addition to the valve handle.

Each valve plug is individually lapped on the valve seat to produce a leakproof fit. Therefore, never put any pressure on the top of the valve plug assembly as this could force the tapered plug more firmly onto its seat and damage the seat faces.

Refer to Section 7.11 to clean the strainers. Should the valve plug be jammed even after pressure equalization described above, refer to Section 7.11.

5.13 ELECTRIC MOTOR

After the compressor has run for twenty minutes, check the motor bearings for temperature and noise. If high temperatures exist, remove the bearing relief plug and run for a further ten min-

utes. If excessively greased, the excess will run out of the open relief plug. If the bearings are noisy, recheck the coupling alignment. Should these problems persist, consult the Electric Motor manual or contact Sullair Refrigeration Service.

5.14 START-UP DATA RECORD

After the compressor has run fully automatically for an hour and the pressures and temperatures have remained stable for 15 minutes, fill out the start-up data record (Figure 5-6). Send a copy to the Sullair Refrigeration Service Department for the permanent file which the Sullair Refrigeration Service Department maintains on your compressor.

▲ CAUTION

Whenever the compressor stops, it runs in the reverse direction for several revolutions. After the discharge check valve closes, the high pressure refrigerant in the oil separator expands back through the compressor to the closed suction check valve which causes the compressor to run in reverse until the pressures are equalized. It is a completely normal action and is no cause for alarm. Continued back spin for more than 5 seconds indicates excess leakage through the suction check valve. Consult Sullair Refrigeration Service Department.

5.15 AFTER START-UP MAINTENANCE

After the compressor has run for 24 hours, clean the suction strainer, oil strainers and change the oil filter if its pressure drop exceeds 30 PSI (207kPa).

Check the compressor shaft seal for excessive leakage of more than 10 drops per minute. If excessive, replace the seal as in Section 7.5.

Section 5
OPERATION

Figure 5-6 Start-up Data Record

START-UP DATA RECORD

CUSTOMER: _____ CONTRACTOR: _____

PERSONS CONTACTED: _____ PERSONS CONTACTED: _____

PHONE: _____ PHONE: _____

TELEX: _____ TELEX: _____

IDENTIFICATION (Section 3.2)

PACKAGE MODEL NO. _____

PACKAGE SERIAL NO. _____

COMPRESSOR SERIAL NO. _____

WIRING DIAGRAM NO. _____

OIL COOLING: LIQUID INJECTION / WATER / DX / THERMOSIPHON SULLISTAGE: YES / NO

PROTECTIVE SWITCH SETTINGS (Sections 3.3 and 4.15)

ANTI-RECYCLE TIMER _____ MINUTES

LOW OIL PRESSURE 25 PSID (175kPa) (FACTORY SET) HIGH OIL TEMPERATURE _____ °F / °C (MANUAL RESET)

LOW DISCHARGE TEMP. _____ °F / °C HIGH DISCHARGE TEMP. _____ °F / °C

LOW SUCTION PRESSURE _____ HIGH DISCH. PRESSURE _____ PSI / kPa
 PSI / in HG / kPag

CONTROL SWITCH SETTINGS (Section 3.3)

SUCTION PRESSURE: (HSP) CUT IN _____ PSI / in / Hg / kPag

CUT OUT _____ PSI / in / Hg / kPag

CAPACITY CONTROL PRESSURE: (P1/P2)

P1 UNLOAD _____ PSI / in / Hg / kPag

P2 LOAD _____ PSI / in / Hg / kPag

Section 5
OPERATION

Figure 5-6 Start-up Data Record

OIL HEATER THERMOSTAT _____ °F / °C (if adjustable)

AMPERE RELAY UNLOAD _____ AMPS

CURRENT TRANSFORMER RATIO _____

OIL PRESSURE DELAY, 1TR _____ SECONDS

CAPACITY CONTROL, 3TR ON _____ SECONDS

OFF _____ SECONDS

LOAD LIMITING, 4TR _____ MINUTES

AUTO, RESTART, 5TR _____ MINUTES (if supplied)

SEQUENCING DELAY, 6TR _____ MINUTES (if supplied)

START-UP OIL PUMP SHUTDOWN, 7TR _____ MINUTES (if supplied)

ELECTRICAL EQUIPMENT

MOTOR MANUFACTURER _____ SULLAIR SUPPLIED: YES / NO

MOTOR SERIAL NUMBER _____

FRAME _____

MOTOR RATED POWER _____ HP / kw

FULL LOAD CURRENT _____ AMP

ELECTRIC SUPPLY _____ VOLTS _____ HERTZ _____ PHASE

STARTER MANUFACTURER _____ SULLAIR SUPPLIED: YES / NO

TYPE _____

STARTER RATED POWER _____ HP / kw

MOTOR OVERLOAD _____ AMPS

CIRCUIT BREAKER _____ AMPS

OPERATIONAL DATA

REFRIGERANT _____

SUCTION PRESSURE _____ PSI / in HG / kPag

SUCTION TEMPERATURE _____ °F / °C

SULLISTAGE PRESSURE _____ PSI / in HG / kPag

Section 5 OPERATION

Figure 5-6 Start-up Data Record

SULLISTAGE TEMPERATURE _____ °F / °C

DISCHARGE PRESSURE _____ PSI / kPa

DISCHARGE TEMPERATURE _____ °F / °C

OIL PRESSURE _____ PSI / kPa

OIL TEMPERATURE _____ °F / °C

OIL FILTER PRESSURE DROP _____ PSI / kPa

OIL TYPE _____

WATER TEMPERATURE: INLET _____ °F / °C OUTLET _____ °F / °C

WATER SUPPLY: CONDENSER / COOLING
TOWER / TREATED / UNTREATED / MAINS / WELL / OTHER _____

CURRENT _____ AMPS AT ABOVE CONDITION WITH
CAPACITY CONTROL AT _____ %

COMMENTS: _____

SULLAIR REPRESENTATIVE SIGNATURE _____

DATE _____

Section 6 MAINTENANCE

6.1 GENERAL

Although the maintenance for your Sullair Refrigeration compressor is minimal, it must be carried out for long compressor life. The instrumentation and indicators provided will alert you of the first sign of a maintenance requirement. Observe these instruments and indicators at regular intervals and be certain that the compressor is performing properly. Become familiar with the normal operating sound of the compressor and if something does not sound just right, shut down the compressor. Excessive vibration is a good indication that something is wrong. This precaution may save the cost of a major repair.

▲ WARNING

Before commencing work on any item on the package, carry out the shutdown procedure in Section 7.2 for your own personal protection.

Keep the compressor package clean to minimize dirt entering the compressor whenever components are opened during routine maintenance.

Before cleaning a component with a solvent to remove gum or resin-like deposits, remove all the o-rings, as they can be chemically attacked. Alternatively, check the compatibility of the solvent with the o-rings which are neoprene or Buna-N. Unfortunately, those solvents which most readily remove carbon deposits (e.g. trichlorethylene) rapidly attack both neoprene and Buna-N. To ensure no traces of solvent will be left to react with the oil and refrigerant, thoroughly dry the component.

6.2 DAILY OPERATION

After a routine start has been made, observe the instrument panel and be sure the gauges indicate the correct reading for that particular phase of operation.

After the compressor has warmed up, check the overall compressor and instrument panel to make sure it is running properly. Particular attention should be given to the following:

- Oil Pressure Gauge
- Oil Temperature Gauge
- Discharge Temperature Gauge

Also check the setting of the suction, oil and discharge pressure protective switches. A log of the operating temperatures, pressures and service requirements can be invaluable in troubleshooting. It is strongly recommended that a log be kept of all readings at least every 8 hours as in Table 9.

While the compressor is running, each sight glass contains slowly churning oil and small vapor bubbles. When clear vapor appears in the top sight glass, the oil level may be low. The oil level can be accurately checked only when the compressor

has stopped and the oil has settled in the separator sump for about 10 minutes. The oil level should be visible in the bottom of the top sight glass.

▲ WARNING

Used or filtered oil should never be added to a refrigeration screw compressor under any circumstance. Use only new oil (as in Section 3.4) from an oil manufacturer (any of the major oil companies or their approved dealers).

Oil should preferably be added after the compressor has stopped or been shut down. Add sufficient oil into the oil separator to bring the oil level to the bottom of the top sight glass with a hand or electric pump capable of pumping oil against a pressure of 100 PSI (689kPa). When the compressor is running, use a hand or electric pump to add oil through a 100 mesh strainer into the normally plugged connection on suction housing of compressor (X3P) next to electric valve actuator (see Figure 2-4 for location of Port X3P).

If the addition of oil becomes too frequent, a problem may have developed causing this excessive loss. See Troubleshooting (Section 6.7) under High Oil Consumption for a probable cause and remedy.

6.3 MAINTENANCE AFTER THE INITIAL 200 HOURS OF OPERATION

After the initial 200 hours of operation, a few maintenance tasks are necessary to rid the system of foreign materials which may have accumulated during assembly and installation. Other procedures stated below are required to ensure that the initial operation of the compressor is correct.

1. Change the oil.
2. Replace the oil filter cartridge or element.
3. Clean all oil strainers.
4. Clean the gas suction strainer.
5. Check the settings of the capacity control cams.
6. Check the settings of the capacity control valve pressure switch (P1/P2).
7. Check the pressure gauge calibration (0 PSIG or 0 kPa) when open to atmosphere.
8. Tighten all bolts, especially motor and compressor mounting bolts.
9. Check compressor shaft seals for excessive leakage over 10 drops per minute. A small oil loss of 1 to 2 drops per minute is normal.
10. Check coupling alignment.
11. Check low oil pressure protective switch.
12. Check high oil temperature protective switch.
13. Check high discharge temperature protective switch.
14. Check start-up oil pressure switch (if supplied).
15. Restart and check all operating temperatures and pressures.

Section 6

MAINTENANCE

6.4 PROTECTIVE CONTROLS

The operations of all protective controls should be checked at least monthly (as in Section 4.15) as a protective switch failure can result in an expensive repair. It is especially important to regularly check the low oil pressure protective circuit for fusing of the switch or delay timer (1TR) contacts or failure of the delay timer coil. Carry out the following two checks after disconnecting the motor power supply, but with power supplied to the control panel.

1. Simulate a start by pushing the START button to energize the main control relay 4CR. After ten seconds, the delay timer 1TR will time out, de-energizing the main control relay and causing the low oil pressure circuit to light up the pilot light on the control panel.
2. Manually trip the low oil pressure switch and again simulate a start as in No. 1 above. After ten seconds, the pilot light should not come on. Remove the manual trip and the pilot light will immediately light up. Note that the low oil pressure switch's differential is factory preset and sealed and requires no field adjustment. Tampering with this device constitutes abuse of the compressor under the terms of the warranty.

6.5 OIL ANALYSIS PROGRAM

The oil injection screw compressor has proven to be a most reliable and successful compressor, but because of the washing action of the oil, the oil quality must be checked closely for maximum compressor life. Since it is impossible to look at the oil and determine its quality, chemical analysis by a qualified concern signifies when to change the oil. Oil analysis has proven to be of great value in preventing lubrication problems by diagnosing poor quality or contamination before significant damage has been done.

WHAT CAUSES THE OIL CONTAMINATION AND BREAKDOWN

Why oil breaks down or becomes contaminated is chemically complex and often cannot be easily evaluated. Several of the problems are:

1. **AMMONIA SALTS** – These are formed with water from oil cooler leaks and condenser leaks during low heat pressure operation, system shutdown, from low side leaks or while system is open for repairs.
2. **EXTERNAL DIRT FINES OR LIQUIDS** – Dirt comes from improperly cleaned new systems or old systems that contain used oil from reciprocating compressors.
3. **POOR OIL QUALITY** – Several systems have had problems with excessive oil breakdown, oil discoloration and/or incorrect oil viscosity. To avoid poor oil quality, purchase one of the Sullair Refrigeration approved oils.

▲ WARNING

Used or filtered oil should never be added to a refrigeration screw compressor under any circumstance. Use only new oil (as in Section 3.4) from an oil manufacturer (any of the major oil companies or their approved dealers).

4. HIGH OIL VISCOSITY – During normal operation, a small amount of oil will be lost from the compressor since the separator cannot be 100% efficient. The oil that escapes tends to be the more volatile constituent resulting in increased viscosity in the remaining oil and improper bearing lubrication.

5. LOW OIL VISCOSITY – If the system has other compressors using lower viscosity oils, the returning oil dilutes the oil and lowers its viscosity.

6. OXYGEN – The air, which is drawn in through valve glands, pinhole leaks in low temperature systems where the evaporating pressure is less than atmospheric pressure, or enters after servicing the system components, forms oxygenated organic compounds. These are a constituent of varnish.

WHAT AN OIL ANALYSIS CHECKS

A proper analysis will check the following basic properties of the oil:

1. Viscosity
2. Color
3. Quantity of particle contamination
4. Moisture content
5. Acid level
6. Chemical analysis of metal contamination including tin, sodium and other reactive metal ions.

Sullair Refrigeration strongly recommends an oil analysis for a new compressor after its initial operation to assist in evaluating potential problems during the early stages of its life. The initial oil analysis and follow up check have resulted in an early warning for many customers of oil contamination, breakdown and changes in viscosity, all of which can affect the lubricating quality of the oil and thus the compressor life.

In order to have this service work carried out most efficiently and effectively, Sullair Refrigeration has designated a laboratory to perform the oil analysis. Sullair Refrigeration Service Department will submit an evaluation of the analysis to you.

With each new compressor package, Sullair includes three (3) oil analysis service kits (P/N 013214). Each kit includes:

1. One (1) "Instructions for Oil Sampling" per kit.
2. One (1) "Oil Sample Bottle Cap" sticker per kit.
3. One (1) "Sullair Oil Sample" sticker per kit.
4. One (1) "Oil Sample Bottle" with cap per kit.

Section 6 MAINTENANCE

TABLE 9
COMPRESSOR LOG EXAMPLE

PLANT NAME _____

MODEL _____ SERIAL NO. _____

DATE _____ LOGGED BY _____ TIME RUN (HOURS) _____

ITEM	SYMBOLS	UNITS	NORMAL RANGE		TIME		
			FROM	TO	8AM	4PM	12PM
SUCTION PRESSURE	Ps	PSIG/in Hg/kPa					
SUCTION TEMPERATURE	Tx	°F/°C					
DISCHARGE PRESSURE	Pd	PSIG/kPa					
DISCHARGE TEMPERATURE	Td	°F/°C					
FLUID PRESSURE (AT MANIFOLD)	Po	PSID/kPa					
FLUID TEMPERATURE (AT MANIFOLD)	To	°F/°C					
FLUID PRESSURE (AT FILTER INLET)	Po-Pd	PSID/kPa					
FLUID PRESSURE (AT FILTER INLET)	Pf	PSIG/kPa					
FLUID FILTER PRESSURE DROP	Pf-Po	PSID/kPa					
WATER TEMPERATURE (AT COOLER INLET)	Ti	°F/°C					
WATER TEMPERATURE (AT COOLER OUTLET)	To	°F/°C					
FLUID LEVEL	-						
FLUID ADDED	-	GAL/L					
CAPACITY	-	%					
MOTOR CURRENT	I	AMP					
RECEIVER LIQUID LEVEL		FT/M					
REFRIGERANT ADDED		LB/KG					
MACHINE ROOM TEMP.		°F/°C					
OUTSIDE TEMPERATURE		°F/°C					
OUTSIDE WET BULB TEMPERATURE		°F/°C					

Section 6

MAINTENANCE

Figure 6-1 Oil Sample Bottle Cap

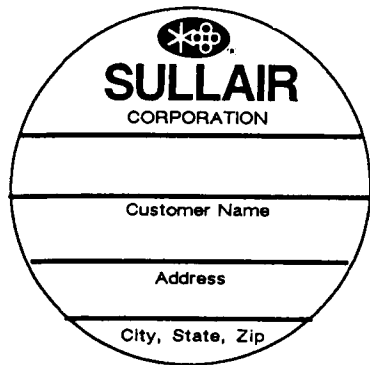

OIL SAMPLE BOTTLE CAP

5. One (1) "Oil Sample Mailer" per kit.

INSTRUCTIONS FOR SULLAIR'S OIL ANALYSIS

Refer to Figures 6-1, 6-2, and 6-3.

1. Oil samples are to be drawn from the oil drain valve on the oil separator sump while the oil is warm. Some oil should be allowed to flow to a waste container before the sample bottle is filled to ensure a representative sampling.
2. A label on the cap of the sample bottle has been provided for sample identification. This label must be properly filled out and attached to the sample bottle cap for the oil sample to be quickly processed (See Figure 6-1).
3. Fill out the "Sullair Oil Sample" form in Figure 6-2. Note that the package serial number from the control nameplate is important and must be included. Remove the backing paper from this tag and attach to sample bottle.
4. Fill out the "Oil Sample Information" sheet in Figure 6-3.
5. Draw the initial oil sample at 150 hours of compressor operation. A new oil sample from your unused stock should be taken at the same time to evaluate the quality of the new oil.
6. Place the 150 hour used sample and the new oil sample in the mailers provided along with

the "Sullair Oil Sample Form" and the "Oil Sample Information Sheet" and mail them First Class directly to the laboratory for prompt analysis.

7. You will receive by mail from Sullair Refrigeration Service Department a summary of the laboratory analysis of your 150 hour oil sample.

NOTE

Regardless of the findings of the 150 hour analysis, the oil must be changed after the initial 200 hours as described in Section 6.3.

8. Draw the second oil sample at 1000 hours of compressor operation.
9. The 1000 hour sample should be accompanied by a filled out "Oil Sample Information Sheet" and again mailed First Class directly to the laboratory for prompt analysis.
10. You will again receive by mail, from Sullair Refrigeration Service Department, a summary of the laboratory analysis of your oil. With the summary of your 1000 hour analysis will come a recommendation on the time interval for future oil checks.

INSTRUCTIONS FOR CONTINUATION OF OIL ANALYSIS SERVICE

After the two initial oil analyses have been completed, Sullair Refrigeration recommends that this oil analysis program be continued as part of a routine maintenance program. After the 150 hour and 1000 hour oil analyses, the following schedule is recommended for oil sample analyses:

1. Every 1000 hours of operation for the first 6000 hours.
2. Every 2000 hours thereafter or any time an unusual problem of discoloration, filter plugging or oil contamination occurs.

The cost of these oil analyses is insignificant when the value of a compressor is considered. It is recommended that your oil analysis program be continued with our designated lab to provide uniformity to the oil analysis, the oil analysis report and Sullair's interpretation of the analysis report. However, if you have had good experience with another laboratory or prefer dealing with your oil supplier, you can continue your oil analysis program with them. Be sure to send reports made by other labs to Sullair Refrigeration Service Department so we may assist you in analyzing the results of the test.

Figure 6-2 Compressor Identification Record



SULLAIR FLUID SAMPLE

MACHINE S/N: _____
HOURLMETER READING: _____
HOURS ON FLUID: _____
DATE SAMPLED: _____
FLUID ADDED: _____
FLUID TYPE: _____

Figure 6-3 Oil Sample Data Sheet

(Return this portion with Oil Sample)

OIL SAMPLE INFORMATION

CUSTOMER NAME _____
ADDRESS _____
CITY & STATE _____ **ZIP** _____
ATTN: _____ **PHONE** _____
SERIAL# _____ **MODEL#** _____
HOURLMETER _____ **HOURS** _____
HOURS SINCE LAST OIL DRAIN _____
OIL TYPE _____
DATE SAMPLE TAKEN _____

Section 6

MAINTENANCE

6.6 MAINTENANCE SCHEDULE

Table 10 is intended as a minimum maintenance schedule. Abnormal conditions may require more frequent action as determined by your daily log readings.

The yearly maintenance jobs should ideally be carried out before the start of the annual season.

TABLE 10

MAINTENANCE SCHEDULE

<u>OPERATION</u>	<u>SCHEDULING TIME PERIOD</u>
1. Check all operating indicators per Section 3.3 operating limits and switch settings.	
Net Oil pressure (equals oil pressure gauge reading minus discharge pressure gauge reading [or minus suction pressure for C40L])	DAILY
Oil Temperature	DAILY
Discharge Pressure	DAILY
Discharge Temperature	DAILY
Suction Pressure	DAILY
Oil Filter Pressure Drop	DAILY
Oil Level	DAILY
Motor Current	DAILY
2. Test all protective controls per Section 3.3 operating limits and switch settings and 4.14 electrical check and 4.15 protective switch check.	
Low Oil Pressure Protective Switch	MONTHLY
High Oil Temperature Protective Switch	MONTHLY
High Discharge Temperature Protective Switch	MONTHLY
High Discharge Pressure/Low Suction Pressure Protective Switch	MONTHLY
Anti-recycle Timer Setting	MONTHLY
Oil Heater	MONTHLY
Refrigerant Relief Valve Leakage	MONTHLY
3. Maintain oil quality per Section 6.5 oil analysis program.	
Sample Oil to Check Appearance and Run Oil Analysis	Every 1000 hours for first 6000 hours and every 2000 hours thereafter.
Change Oil	Every 3 months or 2000 hours unless using oil analysis. Maximum time is 6 months.
Change Oil Filter Cartridge or Element	Whenever oil is changed or when pressure drop across the filter exceeds 30 PSID (207kPa) or is less than 4 PSID (28kPa).
Clean All Oil And Gas Strainers	Whenever oil is changed.

Section 6 MAINTENANCE

OPERATION

4. General Maintenance

Check Noise Level	DAILY
Check Capacity Control Actuator Cam Settings	MONTHLY
Check Capacity Control Actuator Motor	MONTHLY
Check Electric Motor Bearings Temperature	Monthly or as recommended by motor manufacturer.
Lubricate Electric Motor Bearings	Yearly or as recommended by motor manufacturer
Clean Suction Strainer	YEARLY
Check Coupling Alignment and Tighten Coupling Bolts	YEARLY
Tighten Motor and Compressor Mounting Bolts	YEARLY
Inspect Rotor End Play	Every Six Months
Inspect Capacity Control Valve Guides	Every Three Years
Inspect Cleanliness of Oil Coolers	Every six months until required cleaning frequency is established. Intervals between cleaning depends on contamination in cooling water.

6.7 TROUBLESHOOTING

The information contained in the Troubleshooting Chart has been compiled from data gathered from field service reports and factory experience. It contains symptoms and usual causes for the service problems described, however, **DO NOT** assume that these are the only problems that may occur. All available data concerning the trouble should be **systematically analyzed** before undertaking any repairs or component replacement procedures.

With any problem, make a detailed visual inspection and look for heat damaged electrical parts (apparent by discoloration or burnt odor), loose wiring and damaged piping. Then analyze the problem logically step by step with the aid of the Troubleshooting Chart.

Should your problem persist after making the recommended checks, consult the Sullair Refrigeration Service Department.

Section 6 MAINTENANCE

TROUBLESHOOTING

SYMPTOM	PROBABLE CAUSE	REMEDY
COMPRESSOR WILL NOT START	One of the Protective Switches Tripped	Remove cause and reset. Check setting and reset.
	Recycle Timer Activated	Wait for timer to time out.
	No Power Supply to Control Circuit	Check power supply.
	Minimum Position Cam Slipped	Readjust per Section 7.15(F) 7.15(H) and tighten setscrew.
	Minimum Position Microswitch on EVA Defective	Readjust or replace.
	Optional Auxiliary Oil Pump Defective	Check that motor is running in correct direction. Repair.
	Optional Start-up Oil Pressure Switch Out of Adjustment or Defective	Adjust or repair.
COMPRESSOR SHUTS DOWN IMMEDIATELY AFTER STARTING	Low Oil Pressure	See Symptom "Low Oil Pressure" below.
	The Check Valve After Oil Pump Leaks Excessively Allowing Oil to Drain From Filter When Compressor Stops	Oil pump cannot replace drained oil and build-up pressure quickly enough before the low oil pressure protective switch stops the compressor. Replace check valve.
	High Discharge Pressure	Open discharge stop valves and check condenser fan, condenser water pump and purge non-condensables from refrigerant in condenser.
	Low Suction Pressure	Open suction valves. Check capacity control to see if it unloads automatically.
	High Oil or Discharge Temperature	See Symptoms "High Oil Temperature" and "High Discharge Temperature" below.
LOW OIL PRESSURE IMPORTANT DO NOT restart more than two (2) times without pumping one (1) gallon (4 liters) of oil into the oil filter to prelubricate the compressor bearings.	Oil Pressure Relief Valve and/or Oil Pressure Regulating Valve Out of Adjustment Or Defective	Adjust or repair.
	Plugged Oil Strainer	Clean strainer.
	Plugged Oil Filter	Replace cartridge or element. DO NOT clean.
	Low Oil Charge	Check oil level with compressor shut down.
	Broken Oil Pump Shear Pin. This is Indicated by Zero Oil Pressure	Replace.
	Worn Oil Pump	Replace.
	In Minimum Position, Discharge Pressure Too Low for Oil Circulation	Check EVA motor shaft turns from maximum to minimum and reset cams as in Section 7.15(F) or 7.15(H). Reset condenser controls to raise discharge pressure.

Section 6 MAINTENANCE

TROUBLESHOOTING (continued)

SYMPTOM	PROBABLE CAUSE	REMEDY
LOW OIL PRESSURE (cont'd.)	Liquid Refrigerant in Oil	Stop liquid carryover. Check oil heater and evaporator controls. On liquid injection compressors, check and adjust refrigerant regulating valve, solenoid valve and the LDT switch.
	Water in Oil	Change or install filter dryer.
	Low Oil Viscosity	Change oil. Investigate changing lower viscosity oils in other compressors on common system to screw compressor grade.
	Vapor in Oil Cooler	Check vent line on top of cooler.
	Leaking Check Valve on Optional Auxillary Pump Appears When Auxillary Pump Stops (on 7tr)	Repair check valve.
HIGH OIL PRESSURE	Oil Pressure Relief Valve and/or Oil Pressure Regulating Valve Out of Adjustment or Defective	Adjust or replace.
	Oil Temperature Too Low	See "Low Oil Temperature".
LOW OIL TEMPERATURE	Water Regulating Valve or Refrigerant Regulating Valve Out of Adjustment or Defective	Adjust or repair.
	Liquid Refrigerant in Oil	Check oil heater and evaporator controls. On liquid injection compressors, check and adjust refrigerant regulating valve, solenoid valve and the low discharge temperature protective switch. For refrigerant regulating valve, see Symptom "Erratic Oil Temperature".
	Three-way Oil Valve Defective	Clean and check or replace.
HIGH OIL TEMPERATURE	Water Regulating Valve or Refrigerant Regulating Valve Out of Adjustment or Defective or the Wrong Plate Seat (Cv).	Adjust or repair. The water regulating valve and the refrigerant regulating valve are self-contained temperature sensing valves that have a hermetically sealed thermal system. If the charge is lost, the valve will not open. Install a new thermal system.
	Inadequate Water Supply	Clean strainers and check pump.
	Dirty Oil Cooler	Clean tubes. Check water treatment.
	Refrigerant Supply Low (Liquid Injection Compressors)	Check liquid supply, installation and stop valves fully open (see "Erratic Oil Temperature" below).
	Oil in Liquid Refrigerant Supply	Drain oil from liquid receiver and check oil carryover from compressors (see Symptom "High Oil Consumption" below).
	Thermosiphon-Cooled	Three-way valve defective. No liquid supply. Oil in tube-side of oil cooler.

Section 6 MAINTENANCE

TROUBLESHOOTING (continued)

SYMPTOM	PROBABLE CAUSE	REMEDY
HIGH DISCHARGE TEMPERATURE	High Oil Temperature	See Symptom "High Oil Temperature" above.
	Plugged Oil Strainer	Clean strainer.
	Abnormal Operating Condition (e.g. Abnormally High Suction Pressure, High Suction Superheat or High Discharge Pressure)	Check system.
LOW SUCTION PRESSURE	Excessive Suction Line Pressure Drop	Check if system valves are open. Clean suction strainer.
	Capacity Control Not Modulating	See Symptom "Capacity Control Not Operating" below.
	Refrigerant Charge Low	Add refrigerant.
	Evaporators Starving of Refrigerant	Plugged liquid feed strainers. Clean.
HIGH SUCTION PRESSURE	Additional Refrigerating Load Added	Check heat loads.
	Capacity Control Not Modulating	See Symptom "Capacity Control Not Operating" below.
	Excessive Refrigerant in Evaporators	Check liquid feed valves for wear and repair.
	Liquid Refrigerant in Suction Vapor	Check evaporator controls. If problem persists, consider installation of suction liquid trap.
CAPACITY CONTROL NOT OPERATING	Pressure Switch P1/P2 Out of Adjustment or Defective	Adjust per Section 5.7 or replace.
	Timer 3tr Out of Adjustment or Defective	Adjust per Section 5.7 or replace.
	Capacity Control Actuator Out of Adjustment or Defective	Adjust per Section 7.15(F) or 7.15(H).
	EVA Motor Brushes Defective (DC actuator only)	Replace brushes. Brush holder restraining brushes from seating on commutator. File smooth if rough.
	Diodes Defective (DC actuator only)	Replace.
	Circuit Breaker Defective (DC actuator only)	Replace.
	5 amp Fuse Defective (DC actuator only)	Replace.
	No Power at Terminal 40, ITRA; Contact on Line 23 Open. Relay ITRA or Timer ITR Defective	Replace.
	EVA Motor Gears Defective	Replace.
	EVA Motor Defective	Replace.
	EVA Gears Slipping on Shaft	Tighten setscrews.
	EVA Gear Teeth Worn	Replace and lubricate.
	Shaft Bearings Worn; Gears 1 (20) and 2 (23) in Figure 7-14 Will Disengage Under Load When Bearings Worn (Dc actuator only).	Replace bearings.

Section 6 MAINTENANCE

TROUBLESHOOTING (continued)

SYMPTOM	PROBABLE CAUSE	REMEDY
CAPACITY CONTROL NOT OPERATING (cont'd.)	Cam Slipped	Reset per Section 7.15(F) or 7.15(H) and tighten set screw.
	Micro Switch Defective	Replace.
	AC EVA Thermal Overload Open	Automatically resets when overload removed. Check for binding or setting of limit switches.
ERRATIC OIL TEMPERATURE (I) Liquid injection-cooled only (II) Water-cooled only (III) Thermosiphon only	Erratic Liquid Refrigerant Pressure or Supply (I)	Install sight glass and pressure gauge. Add refrigerant or check for improper installation. Check if stop valves are fully open.
	Oil In Liquid Refrigerant Supply (I)	Drain oil from liquid receiver. Check oil carryover from compressors (see Symptom "High Oil Consumption" below).
	Low Condensing Pressure (I)	Turn off condenser fan or water pump.
	Liquid Solenoid Defective (I)	Check coil and valve seat. Repair or replace.
	Plugged Solenoid Strainer (I)	Clean.
	"Top" of Refrigerant Regulating Valve Bulb Not in Vertical Up ("Top" Stamped on End of Bulb Outside of Bulb Well) (I)	Reinstall correctly.
	Refrigerant Regulating Valve Bulb Not in Good Thermal Contact With Bulbwell (I)	Remove bulb and apply grease or aluminum paste.
	Defective Refrigerant Regulating Valve Thermal System (I)	Replace.
	Crushed, Kinked or Twisted Capillary (I)	Repair or replace entire thermal system.
	Foreign Matter in Valve Seat (I)	Clean.
	Valve Stroke Out of Adjustment (I)	Adjust.
	Oversized Port in Valve (I)	Check per Section 7.14 (Table 14) and Sullair Refrigeration Service.
	Valve Plate and Sliding Disc Upside Down in Valve (I)	Turn both 180°; disc arrow to point toward scribe mark.
	Low Discharge Temperature Switch Controlling Discharge Temperature Instead of Regulating Valve (I)	Adjust LDT per Section 5.6.
	Throttle Adjustment Screw in Bypass Solenoid Valve (if supplied) (I)	The expansion screw should be half way open.
Liquid Refrigerant Carryover Entering Compressor Suction (I)	Remove cause for carryover. Verify by placing liquid injection under hand globe valve control with refrigerant regulating valve cranked down to lowest control temperature. If discharge temperature fluctuates under stable suction pressure conditions, liquid carryover is probable.	

Section 6 MAINTENANCE

TROUBLESHOOTING (continued)

SYMPTOM	PROBABLE CAUSE	REMEDY
ERRATIC OIL TEMPERATURE (cont'd.) (I) Liquid injection-cooled only (II) Water-cooled only (III) Thermosiphon only	Packing Too Tight on Regulating Valve (I)	Repack and reset.
	Water Regulating Valve Malfunctioning (II)	Check. Repair or replace.
	Water supply erratic (II)	Air in system. Fluctuations in flow.
	Three-way oil valve erratic (III)	Clean. Repair or replace.
	Erratic refrigerant flow (III)	Check oil fouling of cooler or liquid supply and return lines to cooler.
HIGH OIL CONSUMPTION	Oil Not Returning to Compressor From Final Stage of Oil Separator	Check oil return sight glass at oil separator. If abnormal level shows, clean orifice and/or strainer. Check for any other obstruction in oil return line.
	Oil Separator Element and Gaskets are Incorrectly Seated and Sealed or Defective	Reseat and seal or replace.
	Excessive Oil Charge	Check oil level with compressor off and drain excess oil.
	Liquid Refrigerant in Suction Vapor	Check evaporator controls. If problem persists, consider installation of suction liquid trap. Check suction liquid trap controls.
	Oil Sump Heater Defective Allowing Refrigerant To Condense During an Off Cycle	Replace heater.
	Suction Check Valve Defective e.g. Broken Spring or Missing Seat	Repair or replace. Piston should just close or be slightly open under its own weight.
	Economiser Check Valve Defective	Repair or replace.
	Discharge Pressure Heavily Fluctuating	Adjust condenser controls.
MOTOR RUNS HOT	Too Many Starts in a Short Period	Check the anti-recycle timer. Replace if defective.
	Excessive Current Draw	Check ampere unloading relay and thermal overload. Replace if defective
	Low Voltage	Check voltage at the motor starter and the plant supply. Check the power supply utilities (the voltage at the motor should never be less than 90% of the nameplate rating at the normal full load motor speed).
	Unequal Phase Voltages	Check at the motor starter and the plant supply. Check with power supply utilities.
	Blocked Ventilation Ports	Clean.
	High Ambient Temperature (Above 105°F [40°C]).	Reduce compressor room temperature.

Section 6 MAINTENANCE

TROUBLESHOOTING (continued)

SYMPTOM	PROBABLE CAUSE	REMEDY
MOTOR RUNS HOT (cont'd.)	Motor Internal Centrifugal Fan Backwards	Contact motor supplier.
	Insufficient or excessive grease in bearings	Add or remove grease.
	Bearings defective	Replace or contact motor supplier.
COMPRESSOR VIBRATING OR NOISY	Liquid Refrigerant in Suction Vapor	Check evaporator controls. If problem persists, consider installation of suction liquid trap.
	Coupling Out of Alignment	Realign.
	Rotor End Play Excessive	See Section 7.18. Contact Sullair Refrigeration Service with results.
	Rotor Hitting Slide Valve	Check capacity control valve guide adjustment (see Section 7.20). Readjust.
	Any Other Persistent Vibration or Noise, Contact Sullair Refrigeration Service	

6.8 SEASONAL OR LONG TERM SHUTDOWN

To shut down a compressor for four months or longer, tightly shut both the suction and discharge stop valves, the liquid injection globe valve (if liquid injection cooled) and the Sullistage stop valve (if fitted with Sullistage) enclosing refrigerant at low pressure along with the used oil. Disconnect the power source from the compressor drive motor and the electrical control panel.

Place a moisture-absorbing compound (e.g. a desiccant such as silica gel) inside the control panel and the electric valve actuator. If water-cooled, close the cooling water supply valves and drain the water from the oil cooler. If thermosiphon, close the cooling refrigerant supply valves and evacuate the refrigerant from the oil cooler.

Place warning tags on the electrical system and all closed stop valves. Those who do not know the

compressor is shut down for a long term must not attempt to start the compressor until it is ready for normal operation.

Every month while the compressor is shut down, turn the compressor and motor over several turns.

Prior to starting up after a shutdown, change the oil and pump down the compressor. Before pushing the START button, check items in Section 5.3 noting Items 5 and 7 as shown below.

5. The oil in the separator sump is above 68°F (20°C) or 10°F (6°C) above the saturation temperature of the package pressure, whichever is higher; ideally 80°F to 100°F (27°C to 38°C).
7. Two gallons (8 liters) of oil pumped into the filter to prelubricate the compressor bearings.

Section 7

SERVICING

7.1 GENERAL

The following paragraphs outline the various servicing procedures for the standard Sullair Refrigeration C Series compressors. Special packages may contain parts which do not appear in this manual.

For assistance with any detail of service or servicing of an item not covered by this manual, please consult Sullair Refrigeration Service Department or their agents. Sullair Service Technicians are available from Sullair Refrigeration who will assist on any servicing procedure.

To prevent needless downtime, have available on site all parts that may be needed to carry out the repair before commencing any work.

To prevent dirt from entering opened components, keep the surroundings clean and cover the exposed working areas with plastic whenever possible.

Before cleaning a component with a solvent to remove gum or resin-like deposits, remove all the o-rings, as they can be chemically attacked. Alternatively check the compatibility of the solvent with the o-rings which are neoprene or Buna-N. Unfortunately, those solvents which most readily remove carbon deposits (e.g. trichlorethylene) rapidly attack both neoprene and Buna-N. To ensure no traces of solvent will be left to react with the oil and refrigerant, thoroughly dry the component.

7.2 SHUTDOWN PROCEDURE

WARNING

DO NOT remove caps, plugs and/or other components when compressor is running or pressurized. Stop the compressor and relieve all internal pressure before removing caps, plugs and/or other components.

WARNING

Before commencing work on any item on the package, ensure that the following are carried out for your own personal protection.

1. Whenever the compressor is to be shut down for service, place warning tags on the electrical system and the line valves. Others who do not know the compressor may be faulty or being repaired must not attempt to start the compressor until the servicing is complete and it is ready for normal operation. Exposed electrical wiring must always carry a warning tag even though it is disconnected from the power supply.

2. Stop the compressor with the STOP button on the control panel.
3. Disconnect the starter from the power supply and lock out the disconnect.
4. Disconnect and lockout the control power from the 115V power supply.
5. Close compressor suction stop valve and discharge stop valve.
6. If the compressor is liquid injection cooled and fitted with a relief valve (between the main solenoid valve and the stop valve, relieving to the inlet of the stop valve), close the liquid feed stop valve. **DO NOT** trap liquid refrigerant between valves in a liquid line. If it is not fitted with a relief valve, then make sure liquid refrigerant is bled from the pipe by manually opening the solenoid valve and/or breaking the flanges.
7. If the compressor is fitted with a Sullistage port, close the Sullistage stop valve.
8. Relieve the gas pressure in the package by opening the blowdown valve on the oil separator to either a pump out compressor or other approved means of discharging gas. If using a pump out compressor, pull the package pressure to atmospheric pressure (0 PSIG [0kPa] on the suction pressure gauge) and open the blowdown valve on the separator to the atmosphere.
9. Leave the blowdown valve open to the atmosphere all the time while working on the package.

7.3 BOLT TIGHTENING TORQUES

The tightening torques for servicing the various bolts used in the package are given in Table 11. All fasteners (e.g. the ferryhead screws) used in the compressor unit, are high tensile Grade 8 only and they must always be torqued to Condition B when the compressor is serviced. The fasteners on the package (e.g. flange screws) are medium tensile Grade 5 and the tightening torques in Table 11 may be used as a guide.

Screws of different grades may be distinguished by the number of slashes on the hexagonal head, (e.g. Grade 5 screws have three slashes and Grade 8 screws have six slashes per Table 11). All ferryhead screws are Grade 8.

When a torque wrench is not available, it is possible to approximate these values by using an ordinary wrench or piece of pipe on wrench. For example, to obtain 100 ft./lbs. wrench torque, pull 100 pounds at 1 foot distance from center of pull to center of screw, or pull 50 pounds at a 2 feet distance, etc. in direction perpendicular to the line connecting the center of the screw and the center of pull.



7.4 OIL FILTER CARTRIDGE OR ELEMENT REPLACEMENT

Whenever the oil pressure drop over the filter exceeds 30 PSID (207kPa), the oil filter cartridge or element should be discarded (not cleaned) and

TABLE 11

TIGHTENING TORQUES FOR THREADED BOLTS

FASTENER		TIGHTENING TORQUES: Lb _{ft} in top line Nm in bottom line									
		GRADE 5					GRADE 8				
Diameter	Pitch	Condition (I)					Condition (I)				
Inch	Thread Inch	A	B	C	D	E	A	B	C	D	E
1/4"	20"	8.0 10.8	6.0 8.1	5.5 7.5	4.0 5.4	7.2 9.8	12 16.3	9.0 12.2	8.0 10.8	6.0 8.1	11 14.9
5/16"	18"	17 23	13 17.6	11.5 15.6	8.5 11.5	15.3 21	25 34	18 24	17 23	12.5 16.9	22.5 31
3/8"	16"	30 41	23 31	20 27	15 20	27 37	45 61	35 47	31 42	22.5 31	40 54
1/2"	13"	75 102	55 75	50 68	38 52	68 92	110 149	80 108	74 100	55 75	99 134
5/8"	11"	150 203	110 149	100 136	75 102	135 183	220 298	170 230	147 199	110 149	198 268
3/4"	10"	260 353	200 271	174 236	130 176	234 317	380 515	280 380	255 346	190 258	342 464
7/8"	9"	430 583	320 434	288 390	215 291	387 525	600 813	460 624	402 545	300 407	540 732
1"	8"	640 868	480 650	429 582	320 434	576 781	900 1220	680 922	603 818	450 610	810 1098

GRADE	IDENTIFICATION MARK	TENSILE STRENGTH		YIELD STRENGTH		DIAMETER PSI
		PSI	MPa	PSI	MPa	
5		105,000	725	81,000	560	All Sizes
8		150,000	1035	130,000	900	All Sizes

(I) CONDITIONS

- A - Non-lubricated solvent-cleaned and dry
- B - Lubricated with rust preventative or cadmium or zinc plated
- C - Lubricated with oil or grease
- D - Lubricated with dry lube film or graphite/oil mixture
- E - Lubricated with loctite or sealants

Section 7 SERVICING

Figure 7-1 Oil Filter – New Style

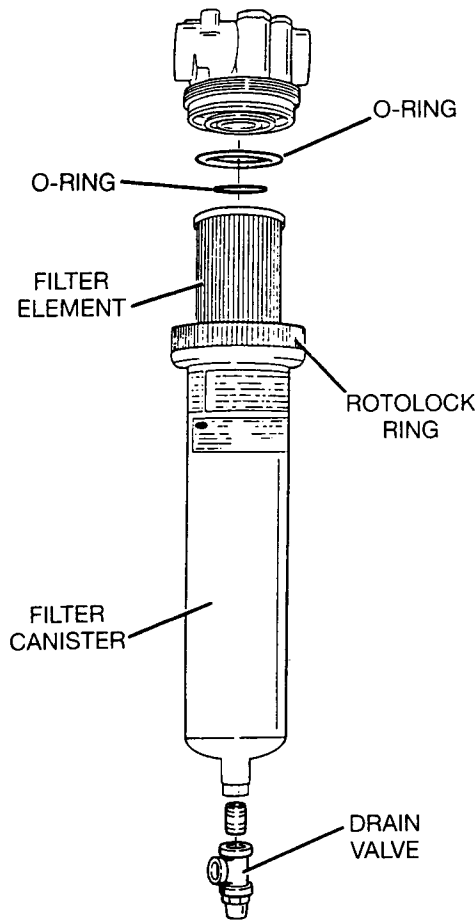

replaced with a new filter cartridge or element. If the oil pressure drop is less than 4 PSID (28kPa), the filter may be defective and should be replaced immediately. In recent years, Sullair has used a new filter. If the filter needs to be replaced, locate the figure which represents the filter mounted on your package (refer to Figures 7-1 through 7-4).

SINGLE FILTER – NEW STYLE

Refer to Figure 7-1.

REMOVAL

1. Carry out the shutdown procedure Section 7.2.
2. Open the drain valve on the bottom of the filter to drain the filter oil and reduce pressure to atmospheric.
3. Loosen the filter canister by turning the rotolock ring. This can normally be turned by hand when the pressure inside the filter has been reduced to atmospheric pressure.
4. As the rotolock ring is turned, it will pry off the filter canister and the ejection spring will loosen the filter element.
5. Discard filter element and clean the filter canister.

INSTALLATION

NOTE

Ensure that the replacement element is Sullair P/N 250008-955 and is labeled.

1. Replace large o-ring.
2. Assemble the filter element into the filter canister with opening in filter element up. Make sure small o-ring is installed properly in the filter element.
3. Set assembly up to the filter manifold and make sure that filter element pushes ejector ring up as rotolock ring is tightened. Hand-tighten rotolock ring only.
4. Pump one (1) gallon (4 liters) of oil through the oil drain valve into the oil filter to replenish the filter chamber.
5. Shut the oil drain valve.
6. Open the compressor suction and discharge stop valves.
7. If the compressor is liquid injection cooled, open the liquid refrigerant stop valve.
8. If the compressor is fitted with a Sullistage port, open the Sullistage stop valve.
9. Reconnect the control panel to the 115V supply line.
10. Reconnect the starter to the electrical supply line.
11. Start the compressor.

SINGLE FILTER – OLD STYLE

Refer to Figure 7-2.

REMOVAL

1. Carry out the shut down procedure in Section 7.2.
2. Open the drain valve on the bottom of the filter to drain the filter oil.
3. Remove the hex socket screws (4) from the bottom plate (1) on the filter body.
4. Remove the large center cap nut (2) and fiber washer (3).
5. Remove the bottom plate (1).
6. Remove the o-ring (5) from the groove in the bottom of the filter body.
7. Remove both felt washers (6) and withdraw the cartridge assembly (7).

INSTALLATION

NOTE

Ensure that the replacement cartridge, Sullair P/N 042712, is labeled AF-450D-Y15.

1. The new cartridge must be rolled prior to installation. The end seams should be directly opposite each other when the cartridge is ready for installation.
2. Insert the cartridge up into the filter body (8) with the central open tube (containing a trian-

Section 7 SERVICING

Figure 7-2 Oil Filter – Old Style

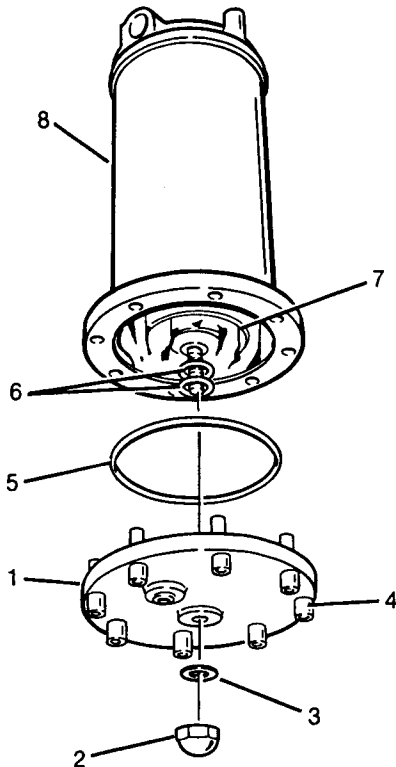

- gular support) inserted first. Push the cartridge filter frame (7) firmly up into the filter head and replace both small felt washers (6) on the bottom of the filter bolt. **DO NOT** place the small felt washers on the top of the filter.
3. Install the new o-ring (5) on the groove in the bottom of the filter body, after smearing it with grease to keep it in place.
4. Place the bottom plate (1) on the filter bolt.
5. Install the hex socket screws (4) and tighten them evenly to 100 lb_ft. (135Nm).
6. Mount the fiber washer (3) on the filter bolt.
7. Install the large center cap nut (2) on the filter bolt and tighten it to 50 lb_ft. (70Nm).
8. Pump one gallon (four liters) of oil through the oil drain valve into the oil filter to replenish the filter chamber.
9. Shut the oil drain valve.
10. Close the blowdown valve.
11. Open the suction stop valve and discharge stop valve.
12. If the compressor is liquid injection cooled, open the liquid refrigerant stop valve(s).
13. If the compressor is fitted with a Sullistage port, open the Sullistage stop valve.
14. Reconnect the control panel to the 115V supply line.

15. Reconnect the starter to the electric supply line.
16. Start the compressor.
17. After the compressor has run long enough for the oil to reach its normal operating temperature, adjust the oil pressure if necessary as explained in Section 5.5.

DUAL FILTER – OLD STYLE (OPTIONAL)

Refer to Figure 7-3.

The old style dual filter arrangement consists of two (2) filter housings, two (2) check valves and a 3-way valve.

The dirty filter element can be changed while the compressor is running.

CAUTION

Proceed carefully when opening filter while compressor is pressurized in the event the check valves or 3-way valve leak.

1. Rotate the 3-way valve so oil is flowing through the clean filter.
2. Remove and replace the filter cartridge as above for the single filter.

Figure 7-3 Dual Filter – Old Style

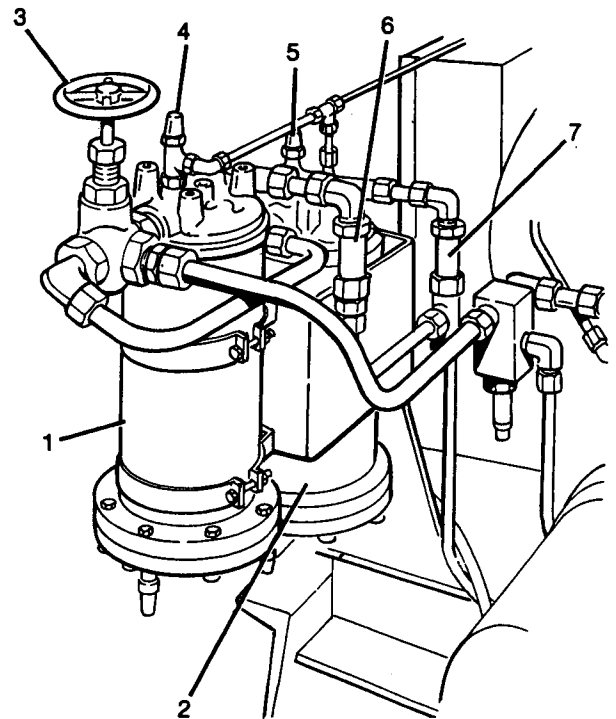

Section 7 SERVICING

Figure 7-4 Dual Filter – New Style

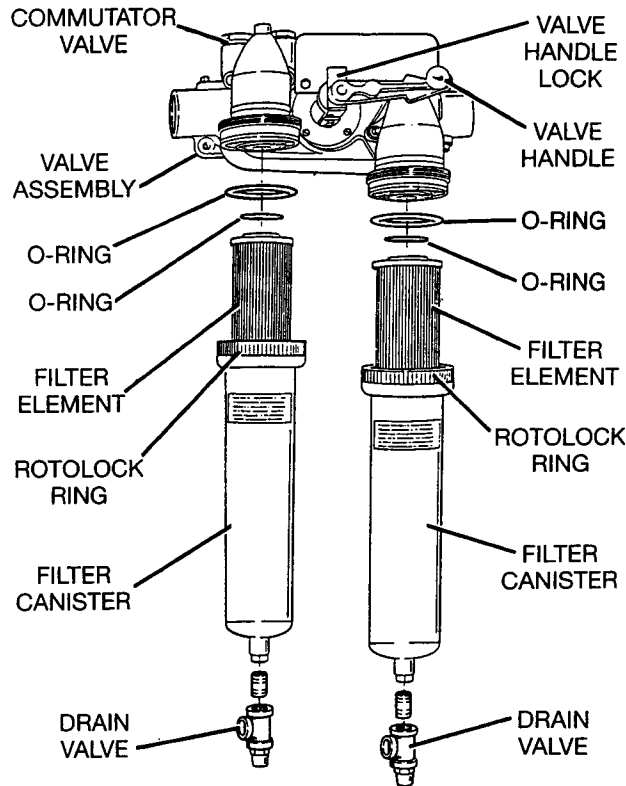

DUAL FILTER – NEW STYLE (Optional)

Refer to Figure 7-4. If your compressor is equipped with the optional dual filter, the filter canister can be replaced while the compressor is running.

CAUTION

As compressor is pressurized, all steps must be performed with extreme caution in the event of leakage around the filter seals, and the resultant possibility of high pressure gas being present.

REMOVAL

1. Make sure commutator valve is open.
2. Slowly rotate valve handle to point to clean filter.
3. Close commutator valve.
4. Open the drain valve on the bottom of the dirty filter to drain the oil and reduce canister pressure to atmospheric.
5. Loosen the filter canister by turning the rotolock ring. This can normally be turned by hand when the pressure inside the filter has been reduced to atmospheric pressure.

6. As the rotolock is turned, it will pry off the filter canister and the ejector spring will loosen the filter element.
7. Discard the filter element and clean the filter canister.

INSTALLATION

NOTE

Make sure that the replacement element is Sullair P/N 250008-955 and is labeled.

1. Replace large o-ring.
2. Assemble the filter element into the filter canister with opening in the filter element up. Make sure that the small o-ring is installed properly in the filter element.
3. Set the assembly up to the filter manifold and make sure that the filter element pushes the ejector ring up as the rotolock ring is tightened. Hand tighten the rotolock ring only.
4. Close the oil drain valve.
5. Slowly open the commutator valve to allow clean oil into the filter.

7.5 SHAFT SEAL REPLACEMENT

Refer to Figures 7-5 and 7-6.

1. Carry out the shutdown procedure in Section 7.2.
2. Remove the coupling guard, coupling spacer and coupling hub from the compressor shaft as in Section 7.6.
3. Disconnect oil supply line and drain line from the shaft seal cover.
4. Loosen evenly the four bolts (2) between the shaft seal cover and the outlet housing.
5. Remove the shaft seal cover (1). The flange can be broken loose by tapping with a rubber hammer.
6. Remove the seal housing (6). Use screws in the three tapped holes to remove the housing easily.
7. Remove the rotating seal (4) by pulling it off the shaft by hand.

PREPARATION

1. The seal has a secondary teflon seal which seals against the shaft. Check that this secondary seal lip is uniform around its periphery even though the seal is brand new. This teflon seal is kept unloaded by four clips mounted on the outside of the seal which keep the springs compressed and thereby the teflon seal unloaded.
2. Place the seal on a clean flat surface with the carbon face up.
3. Remove one clip and braise (or tie) the end of a six inch (152 mm) wire to it as in Figure 7-6. (This is done so the clip will not be lost inside the compressor when it is later removed from the seal when the seal is mounted on the

Section 7 SERVICING

Figure 7-5 Shaft Seal Assembly

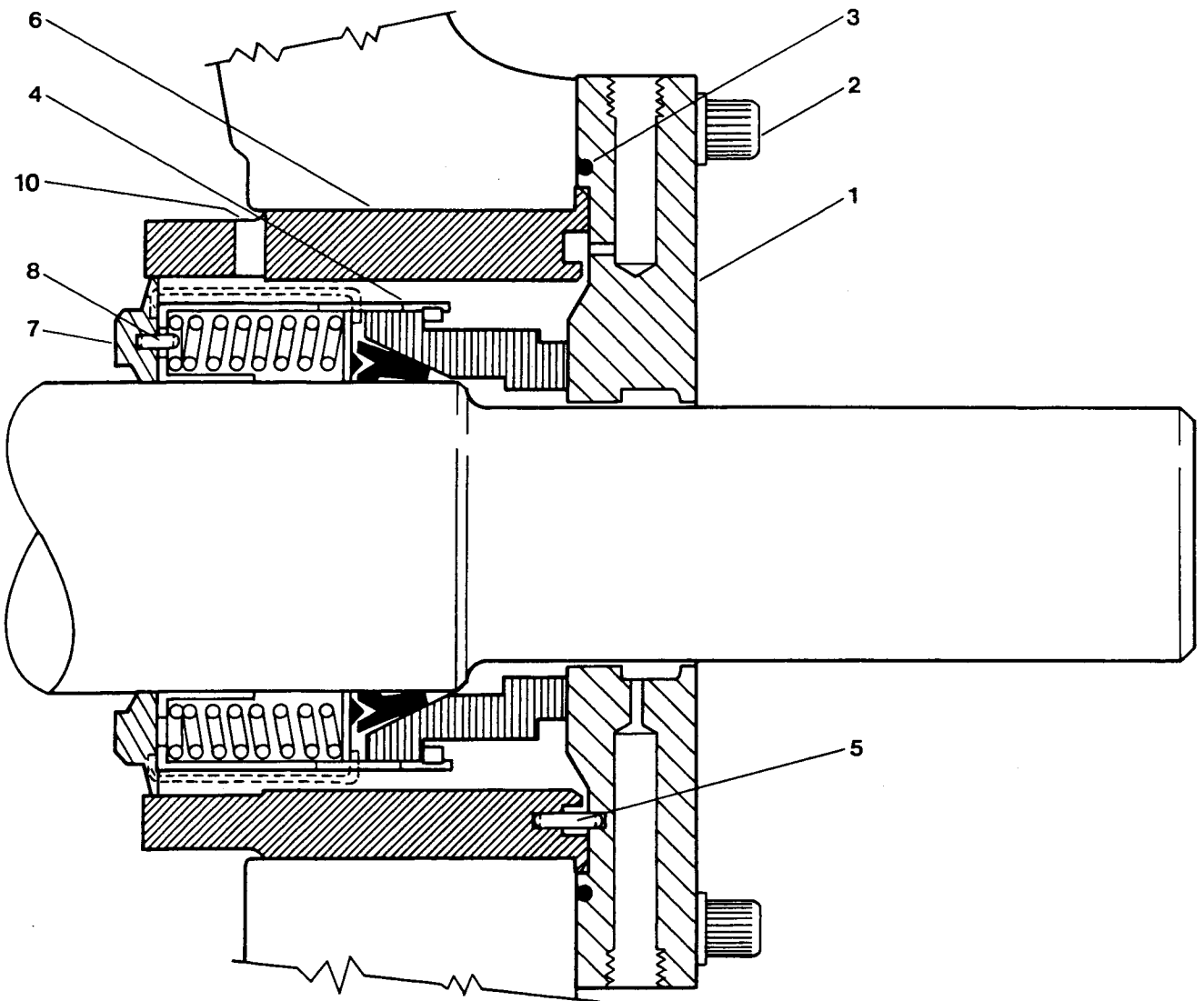

- shaft). **DO NOT** braze the clip while on the seal body.
4. Replace the clip on the seal with the wire pointing to the carbon.
 5. Repeat Steps 3 and 4 for each of the remaining clips one at a time.
 6. Check the shaft for any burrs or sharp edges which could cut the seal when it is later slid over the shaft. Remove all burrs and break all sharp edges.

CAUTION

Be careful not to let any material get into the bearing area.

7. Inspect and clean the shaft where the seal is going to be mounted especially in the vicinity of the teflon secondary seal. Remove carbon deposits with a light solvent (such as mineral or methylated spirits).

Section 7 SERVICING

Figure 7-6 Shaft Seal Assembly

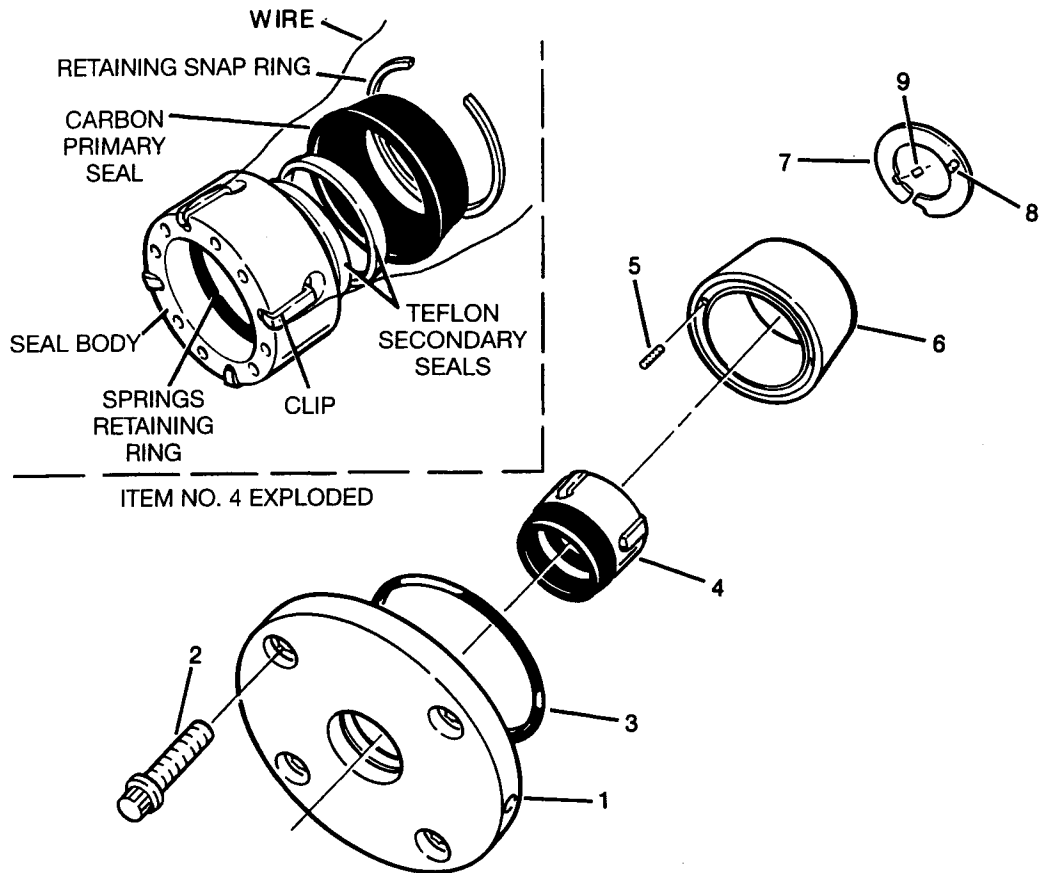

8. Clean all parts thoroughly. Wipe off any foreign material and use a light solvent to remove carbon deposits.
9. Make sure both the oil supply orifice and the oil drain line in the new cover (1) are open and the threads are clean.
10. Oil the shaft and the inside of the rotating seal member (4) with clean refrigeration oil. Check that the carbon face is absolutely clean with no surface scratches.

⚠ WARNING

The seal assembly must be started squarely over the shaft by hand force. If the seal assembly becomes locked on the shaft, remove and start again. Excessive force should not be necessary. Extreme caution must be exercised not to damage the lapped carbon surface and to keep it clean. DO NOT bend or tear the teflon rings.

INSTALLATION

⚠ WARNING

The seal is kept unloaded by four clips mounted on the outside of the seal. These clips must not be taken off until the seal is in its operating position.

1. Install the rotating seal member on the shaft. Slide the seal down the shaft until it contacts the drive disc (7). Make sure that the drive pin (8) enters either the U slot or one of the holes in the back face of the seal.

If the teflon secondary seal is a tight fit, there could be difficulty sliding the seal over the shaft and bottoming on the drive disc (7). If this is the case, remove the seal from the shaft and, taking care not to accidentally dislodge the clips, remove the retaining snap ring and the two teflon secondary seals from the seal cage (4).

Reinstall the empty seal cage on the shaft. Slide the seal cage down the shaft until it contacts the drive disc (7) and the drive pin (8) enters either the U slot or one of the holes in the back face of the seal.

Install the teflon wedge on the shaft as in Figure 7-6. Oil the inside of the teflon secondary

Section 7 SERVICING

seal and slide it down the shaft using care not to damage the thin sealing lip. Install the carbon face and snap retaining ring, again taking care not to accidentally dislodge the clips.

2. With fingers spread equally around the carbon face, press the carbon face lightly against the springs and gently remove the clips in opposite pairs. Keep the clips with their attached wires for a future seal service.

⚠ WARNING

Ensure that the clips are not dropped into the compressor. If a clip does drop into the compressor it must be recovered.

3.

⚠ WARNING

Tap very lightly and evenly with a blunt punch or large screwdriver around the seal body casing to move the seal up against the drive ring. Use care not to hit the carbon.

4. Make sure that the roll pin (5) is mounted in the seal housing (6).
5. Mount the seal housing (6) making sure that the overflow hole (10) is pointing upwards.
6. Inspect the new stationary seal cover (1) for any surface imperfections and oil the surface with clean refrigeration oil.

NOTE

Some early models have a stationary seal member mounted with an o-ring in a cover plate. Ensure that the bore is clean and has a smooth surface before oiling the o-ring and mounting together.

7. Replace the o-ring (3) in the cover plate (1) with a new one.
- 8.

⚠ WARNING

Always install a new seal cover plate (1) with a new seal assembly (4).

Mount the new seal cover plate, aligning it with the roll pin (5), and tighten the screws (2) diagonally and evenly so as not to crack the carbon. Tighten the 1/2 inch screws to a torque to 80 lb·ft. (108 Nm).

9. Connect the oil supply tube and the drain line.
10. Pump one gallon (four liters) of oil into the oil filter to replenish the seal housing.
11. Turn the compressor shaft a few turns by hand.
12. Close the blowdown valve.

13. Open the suction stop valve slowly to pressurize the package.
14. Check that the seal is not leaking.
15. Open the discharge stop valve.
16. If the compressor is liquid injection cooled, open the liquid injection stop valve.
17. If the compressor is fitted with a Sullistage port, open the Sullistage stop valve.
18. Mount the coupling hub, coupling spacer and coupling guard (see Section 7.6 on coupling servicing).
19. Reconnect the control panel to the 115V supply line.
20. Reconnect the starter to the electric supply line.
21. Start the compressor.

7.6 COUPLING SERVICING

Refer to Figures 7-7, 7-8 and 7-9. The non-lubricated flexible element shaft coupling requires no service other than alignment or replacement of the flexible elements.

COUPLING REMOVAL

1. Carry out the shutdown procedure in Section 7.2.
2. Remove the coupling guard.
3. Remove the coupling spacer (5) and flexible elements (4) by removing the nuts, bolts, and thin and thick washers. Note the orientation of the thick and thin washers with the bevel facing the element pack.
4. Tie a wire through one bolt hole of each element pack to retain the original orientation of each element in the pack and to ensure that each element pack contains the same number of elements.

REMOVAL OF HUB WITH TAPERED BUSHING

1. Mark the hub, bushing and shaft with a felt pen to give the correct angular orientation for reassembly.
2. Remove all the screws from the hub.
3. Oil the thread and point of setscrews, or if capscrews are used, oil their threads and under their heads.
4. Loosen the bushing in the hub by inserting screws in the holes that are threaded on the bushing side (as shown in Figures 7-7, 7-8 and 7-9). Note that one screw in each hub is left over and is not used in this loosening operation.
5. If the bushing does not readily loosen, tap on the hub.

REMOVAL OF HUB WITHOUT TAPERED BUSHING

1. Mark the hub and shaft with a felt pen to give the correct angular orientation for reassembly.
2. Remove the setscrew from the hub if fitted.
3. Remove the hub by evenly pulling on the hub by hand or using a gear puller.
4. If the hubs were mounted with an interference fit, gently heat the hub evenly with a soft open

Section 7
SERVICING

Figure 7-7 Formsprag QD Coupling

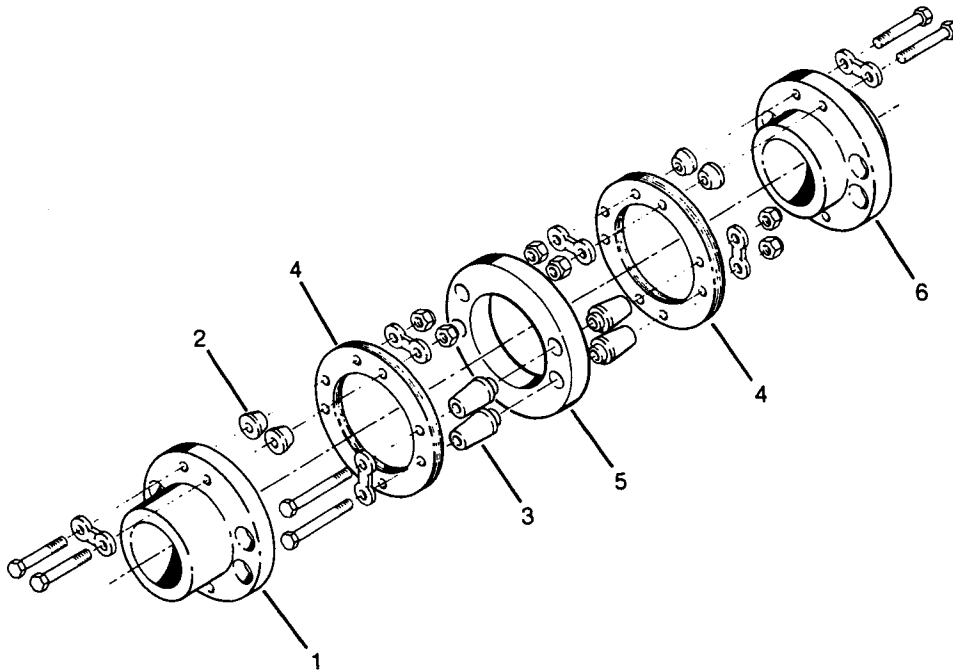

Figure 7-8 Formsprag Taperlock Coupling

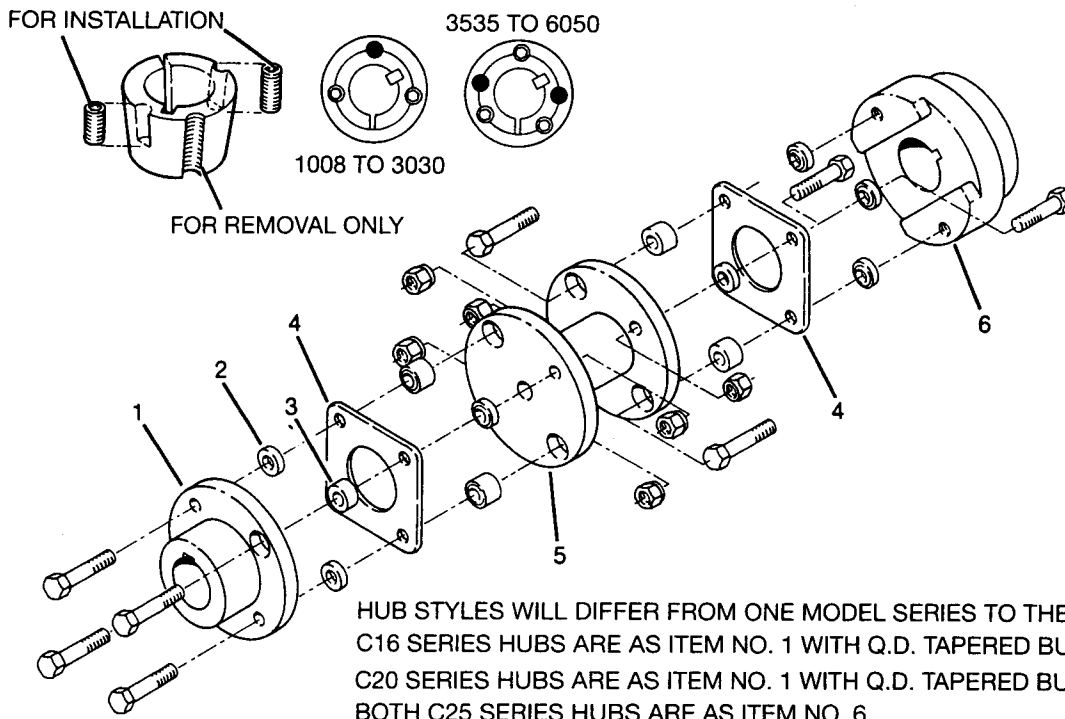

Figure 7-9 Thomas Coupling

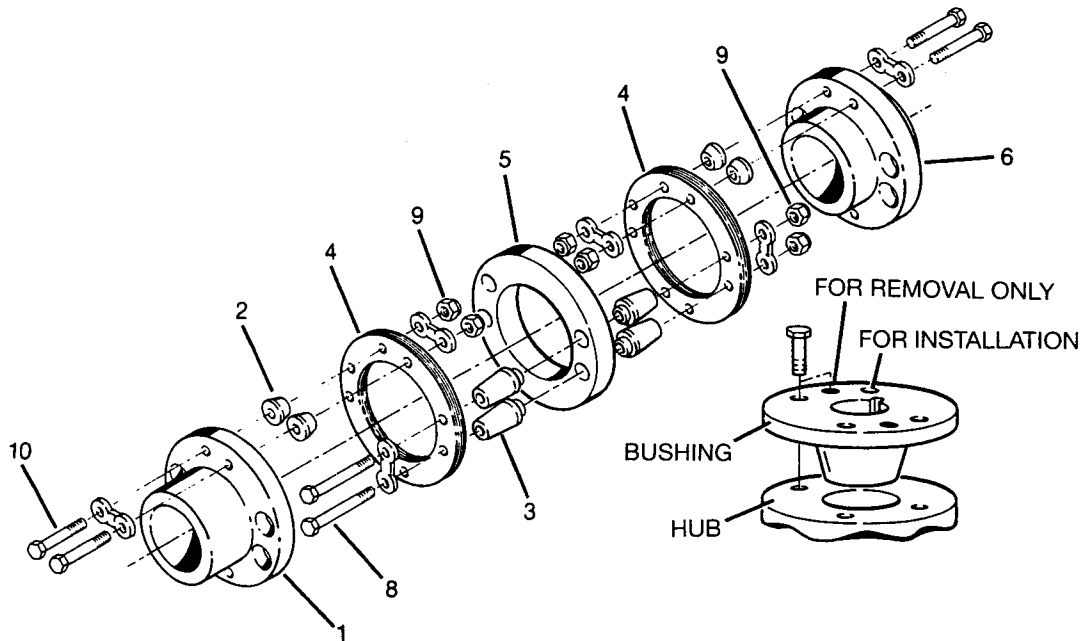

TABLE 12
TAPERLOCK BUSHING TIGHTENING TORQUES

BUSHING NO.	SCREWS	TORQUE	
		lb.·in.	Nm
1008, 1108	¼" Set Screws	55	6
1210, 1215, 1310	⅜" Set Screws	175	20
1610, 1615	⅜" Set Screws	175	20
2012	⅞" Set Screws	280	30
2517, 2525	½" Set Screws	438	50
3020, 3030	⅝" Set Screws	800	90
3535	½" Cap Screws	1000	115

Section 7 SERVICING

flame to expand the hub and remove as in Steps 2 and 3 above.

ASSEMBLY OF HUB WITH TAPERED BUSHING

1. Clean the shaft including the keyway, the bore and the outside of the bushing and the bore of the hub (taking bushing from the hub if already assembled). Remove any oil, lacquer, dirt or burrs.
2. Place the bushing in the hub and match the half holes to make complete holes. Note each component hole will be threaded on one side only on taperlock bushing.
3. Oil the threads and points of setscrews, or if capscrews are used, oil their threads and under the heads.
4. Place screws loosely in the holes that are threaded on the hub side as shown in Figures 7-7, 7-8 and 7-9.
5. Fit the key in the shaft keyway such that the end of the key is flush with the end of the shaft.
6. Make sure the bushing is free in the hub. Install the assembly onto the shaft and locate so that the distance between the two flanges is that given in Table 13, and the felt pen angular marks line up.
7. Tighten the screws alternately and evenly until pulled up tightly to the torque given in Table 12.
8. Tap against the large end of the bushing with a lead hammer to avoid damage. The screws can usually be turned a little more using the specified torque. Repeat this alternate hammering and retightening until the specified torque no longer turns the screws after hammering.

ASSEMBLY OF HUB WITHOUT TAPERED BUSHING

1. Clean the shaft including the keyway and the bore of the hub. Remove any oil, lacquer, dirt or burrs.

2. Fit the key in the shaft keyway such that the end of the key is flush with the end of the shaft.
3. Mount the hub on the shaft. Alternatively, if the hubs have been bored for an interference fit, heat the hubs in an oil bath at 200°F (93°C) for 15 minutes and then quickly mount on the shaft.
4. Locate the hub such that the distance between the two hub flanges is that given in Table 13, and the felt pen angular marks line up.
5. Tighten the hub setscrew if fitted.

COUPLING ASSEMBLY

1. Align the coupling as in Section 4.10.
2. Hold or support the coupling spacer and one element pack in position.
3. Insert the bolts through the washers and the element pack.

⚠ WARNING

Ensure that both the thick and thin washers are oriented with the bevel or radius facing the element pack.

4. Alternately and evenly tighten each locknut to the torques given in Table 13. It is preferable to turn the locknut and not the bolt to prevent scoring of the fine-turned bolt.
5. Install the coupling guard.
6. Close the blowdown valve.
7. Open the suction stop valve and discharge stop valve.
8. If the compressor is liquid injection cooled, open the liquid refrigerant stop valve.
9. If the compressor is fitted with a Sullistage port, open the Sullistage stop valve.
10. Reconnect the control panel to the 115V supply line.
11. Reconnect the starter to the electric supply line.
12. Start the compressor.

TABLE 13

COUPLING INSTALLATION DETAILS

COUPLING MAKE	COMPRESSOR MODEL	FLANGE CENTER (inch)	DISTANCE (mm)	TIGHTENING TORQUE		USUAL BUSHING NUMBER	SULLAIR NUMBER
				lb./ft.	Nm		
Formsprag Taperlock	C16 (I)	5" ± 0.03	127 ± 0.76	40	54	2012	240040
	C20 (I)	5" ± 0.05	127 ± 1.27	40	54	2525	240041
	C25	5" ± 0.06	127 ± 1.52	80	108	3030	046001
Thomas Taperlock	C16 (I)	5" ± 0.03	127 ± 0.76	43	58	2012	240040
	C20 (I)	5" ± 0.05	127 ± 1.27	95	129	2525	240041
	C25 (II)	5" ± 0.06	127 ± 1.52	175	237	3030	046001
Formsprag QD	C16	4 7/8" ± 0.03	124 ± 0.76	42	57	SF	408999
	C20	4 7/8" ± 0.05	124 ± 0.76	42	57	SF	408999

(I) Part Number 240040 and 240041 supplied on packages built prior to January 1, 1982.
 (II) Thomas taperlock supplied on packages built prior to January 1, 1982.

Section 7 SERVICING

7.7 OIL PRESSURE RELIEF AND REGULATING VALVE SERVICING

Refer to Figures 7-10 and 7-11.

1. Carry out the shutdown procedure in Section 7.2.
2. Replace the entire valve with a new valve.
3. Close the blowdown valve.
4. Open the suction stop valve and discharge stop valve.
5. If the compressor is liquid injection cooled, open the liquid refrigerant stop valve.
6. If the compressor is fitted with a Sullistage port, open the Sullistage stop valve.
7. Reconnect the control panel to the 115V supply line.
8. Reconnect the starter to the electric supply line.
9. Start the compressor.
10. Run the compressor until the oil is at its normal operating temperature as in Section 3.3.
11. Adjust both the oil pressure relief valve and the oil pressure regulating valve as in Section 5.5.

7.8 WATER-COOLED OIL COOLER CLEANING

The internal diameter of the $\frac{5}{8}$ " (15.8mm) tubes in the standard cooler is 0.402" (10.2mm).

The internal diameter of the $\frac{3}{8}$ " (9.5mm) tube cooler is 0.300" (7.6mm).

1. Disconnect the starter from the electric supply line and lockout the disconnect.
2. Disconnect the control panel from the 115V electric supply line.
3. Close water supply and return stop valves.
4. Remove the connecting water pipework from the cooler head(s).
5. If mechanical tube cleaning is desired, proceed to Steps 7, 8, 9, 10 and 11.
6. Fit the necessary hose and fittings to the cooler head and flush through a proprietary chemical according to the manufacturer's instructions. Alternately flush through a mild 4% sulfamic acid solution for 15 minutes or until no more scale exists in the outlet acid. As a last resort use a very weak 2% sulfuric acid solution with care as tube damage may result.
7. Remove the cooler heads from each end.

NOTE

To retain the correct angular orientation of the cooler heads make two marks adjacent to each other on the cooler head and the cooler with a punch or a file.

8. With a rotary wire brush mechanically brush each tube in turn ensuring that the brush reaches the far end. Make sure all tubes are cleaned, otherwise the flow may be partially blocked in some tubes causing overheating or cooling which results in severe expansion stresses, loosened tube joints and fractured tubes.

Figure 7-10 Oil Pressure Relief Valve

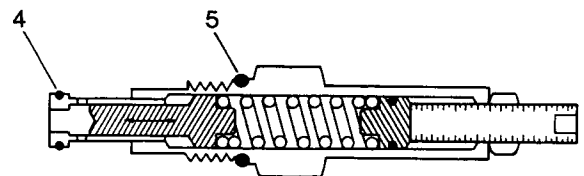
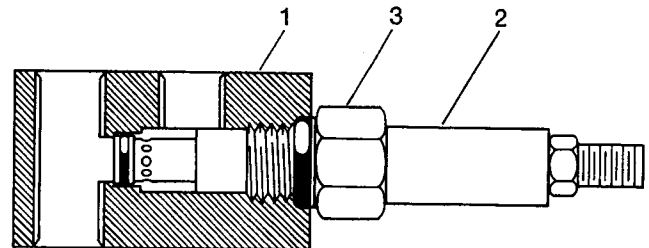
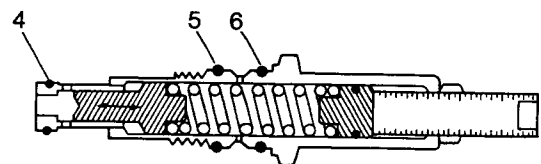
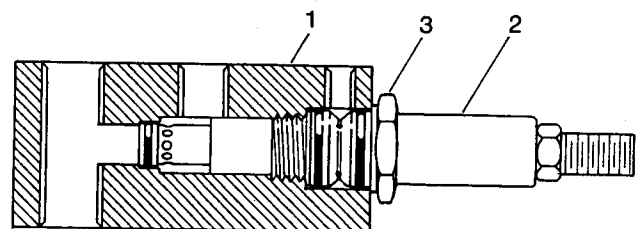

Figure 7-11 Oil Pressure Regulating Valve



Section 7

SERVICING

9. Clean the heat exchanger and cooler heads.
10. Mount both cooler heads with new gaskets. Align cooler heads with marks on cooler head and cooler. Tighten the cooler head bolts in a uniform, diametrically staggered pattern.
11. Thoroughly flush the cooler with clean water and dispose of this effluent properly.
12. Reconnect the water pipework to the cooler head(s).
13. Open the water supply and return stop valves.
14. Reconnect the control panel to the 115V electric supply.
15. Reconnect the starter to the electric supply line.
16. Start the compressor.
17. After running for 15 minutes adjust the water regulating valve if necessary to achieve an operating oil temperature per Section 3.3.

7.9 THERMOSIPHON COOLER CLEANING

This cooler should never need cleaning under normal use. However, the refrigerant used for cooling will carry oil with it. This oil may tend to remain in the cooler as the refrigerant. Therefore this oil will have to be drained from the cooler on a periodic basis.

7.10 OIL STRAINER SERVICING

The strainers in standard packages are shown per the schematics (Figures 2-5, 2-6, and 2-7).

1. Carry out the shutdown procedure as in Section 7.2.

⚠ WARNING

If a pump out compressor is used to evacuate refrigerant from the package, **DO NOT** lower the package pressure to less than atmospheric and be sure to open the blowdown valve on the separator to the atmosphere. If this is not done, when the strainer plugs are removed, the sudden inrush of air to break the vacuum will backflush the foreign matter from the strainers into the lines. After reassembling the apparently clean strainers and running the compressor, the strainers will again plug up.

2. Loosen the hexagonal screw-in plug in the end of the strainer until the plug is held by about two threads.
3. Place a receptacle underneath the strainer to catch oil.
4. Unscrew the plug by hand, quickly remove the strainer screen from the recess in the plug and screw the plug about two threads into the empty strainer body.

⚠ CAUTION

Be careful to avoid being burned by the hot oil. Use rags or waste cloths for protection.

5. Remove any foreign matter from inside the strainer screen (e.g. fibers) and clean the strainer screen with a light solvent (e.g. mineral spirits).
6. Again, unscrew the plug by hand, and quickly insert the strainer screen into the plug recess. Renew the plug gasket, if necessary, and screw the plug into the strainer body. Tighten the plug.
7. While the compressor package is blown down, clean all of the oil strainers as in Steps 2 through 6.
8. Close the blowdown valve.
9. Open the suction stop valve slowly to prevent compressor shaft rotation and then open discharge stop valve.
10. With the package pressurized, check that none of the strainers are leaking and, if necessary, tighten the plug(s) further.
11. If the compressor is liquid injection cooled, open the liquid refrigerant stop valve.
12. If the compressor is fitted with Sullistage port, open the Sullistage stop valve.
13. Reconnect the control panel to the 115V supply line.
14. Reconnect the starter to the electric supply line.
15. Start the compressor.

DUAL OIL STRAINER SERVICING

It is necessary to shut the compressor down as in Section 7.2 only to repack the valve stuffing box as described below. The dual strainers have tapered valve plugs which are factory assembled. In operation, one side of the valve is exposed to the pressure developed on the strainer chamber in use and the other side is exposed to a lower pressure. With the valve properly adjusted, there will be little, if any, equalization of pressure through the valve and consequently, the pressure on one side will tend to press the tapered plug against the low pressure side. If the pressure is great enough, this pressure causes the valve to operate rather stiffly. To remedy this condition, a bypass line and stop valves are provided.

When it is desired to shift operation of the strainer from one chamber to the other, open the valves in the bypass line so that the pressure in both chambers is equalized. Then swing the valve, using the handle provided, toward the chamber to be put in operation. The handle will move easily when the pressure is equalized. Finally, close the valve in the bypass line before opening the cover of the strainer chamber.

⚠ WARNING

NEVER try to force the valve plug assembly through its cycle of operation. It should at all times move freely without the aid of any additional leverage other than that provided through the mechanical advantage of the valve handle.

Figure 7-12 Dual Oil Strainer - Old Style

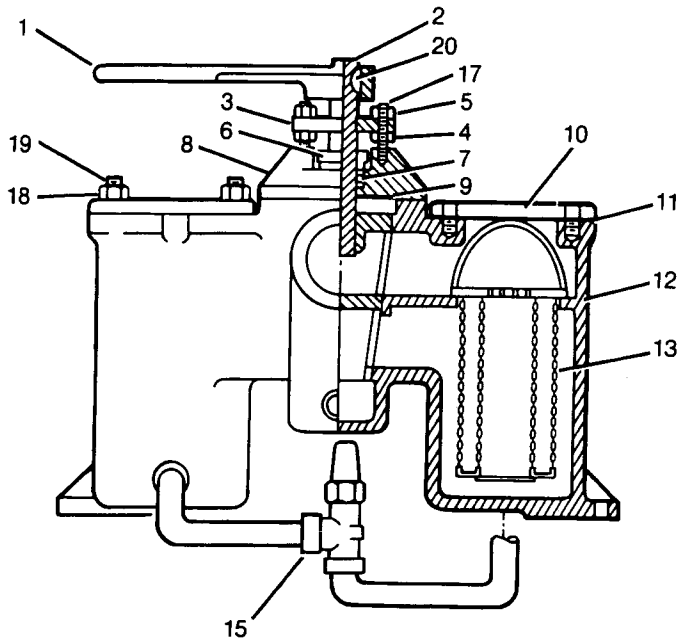

Each valve plug is individually lapped on the valve seat to produce a leakproof fit. Therefore, never put any pressure on the top of the valve plug assembly, as this could force the tapered plug more firmly onto its seat and could result in damaged the seat faces.

ADJUSTMENT OF VALVE PLUG (OLD STYLE ONLY)

Refer to Figure 7-12. Remove the strainer baskets as described below. It is possible, even after pressure equalization as described above, that the valve plug may be jammed at the valve seat faces because of unequal expansion of adjacent parts. Raise the plug slightly off its tapered seat by turning the lifting jack nut $\frac{1}{8}$ of a turn counter-clockwise and turning the valve handle. If still jammed, adjust the valve plug.

1. Loosen hex nuts (5) slightly and be sure the set screw in the handle hub (1) is tight. Place a piece of flat stock under the handle hub (1) and using locking flange stud (17) as a fulcrum, pry firmly so that the valve plug assembly (2) is lifted in a vertical direction while the valve housing casting is tapped with a hammer.

2. To readjust the valve, tighten hex nuts (5) evenly and a very little amount at a time. While doing this constantly, try the action of the valve plug assembly (2) by moving the valve handle (1) through its cycle of operation. When the valve action just begins to feel tight or snug, the valve is in its proper position.
3. To determine whether or not the valve is bypassing liquid, remove the cover (10) of the chamber not in use and if the level of the liquid in this chamber continues to rise, it will be necessary to further position the plug. Adjust until the liquid level remains stationary.
4. To hold the plug in position, bring the hex jam nuts (4) up against the underside of the locking flange (3).

STRAINER BASKET REMOVAL AND INSTALLATION - OLD STYLE

Refer to Figure 7-12.

1. Equalizing valve (15) must be closed.
2. Loosen the stud nuts (18) a few turns and carefully pry up the cover (10) to relieve the pressure. **DO NOT** remove the stud nuts until the chamber is depressurized.

▲ CAUTION

Be careful to avoid being burned by the hot oil. Use rags or waste cloths for protection.

3. Remove the stud nuts (18) and cover (10) of the strainer chamber not in use.
4. Lift out the strainer basket (13) and clean.
5. Clean the cover seat and cover (10).
6. Install the clean strainer basket (13).
7. Replace the cover (10) and stud nuts (18). As the studs are screwed down, the strainer basket handle is compressed, holding the strainer basket firmly in place.
8. Re-open equalizing valve (15) to recharge the cleaned strainer basket with clean oil.

▲ CAUTION

Be sure equalizing valve is closed while removing basket.

STRAINER BASKET REMOVAL AND INSTALLATION - NEW STYLE

Refer to Figure 7-13.

1. Open equalizing valve at bottom of strainer to be removed.
2. Remove plug slowly from tee to relieve pressure from basket area.

▲ CAUTION

Be sure valve at bottom of strainer that is being used is closed while removing basket that is not being used.

Section 7 SERVICING

Figure 7-13 Dual Oil Strainer – New Style

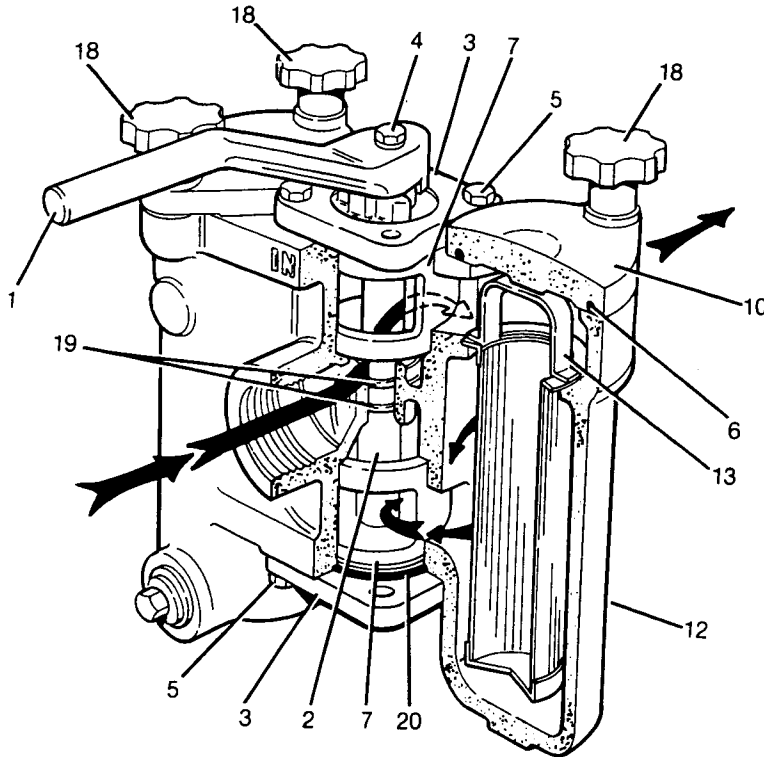

- Loosen knobs (18) a few times and carefully pry up the cover (10) to relieve the pressure. **DO NOT** remove the knobs until the chamber is depressurized.

⚠ CAUTION

Be careful to avoid being burned by the hot oil. Use rags or waste cloths for protection.

- Remove the knobs (18) and cover (10) of the strainer chamber not in use.
- Lift out the strainer basket (13) and clean.
- Clean the cover seat and cover (10) and o-ring groove.
- Install the clean strainer basket (13) with clean o-ring (6).
- Replace the cover (10) and knobs (18). As the knobs are screwed down, the strainer basket handle is compressed holding the strainer basket firmly in place.
- Install plug into tee and tighten.
- Open both valves in bottom of the strainer to re-charge cleaned strainer with clean oil.

PACKING REPLACEMENT (OLD STYLE ONLY)

Refer to Figure 7-12.

- Carry out the shut down procedure in Section 7.2.
- Remove the valve handle (1) and woodruff key (20).
- Remove the hex nuts (5) or hex bolts (5). Remove the locking flange (3).
- Remove the hex head capscrews (not shown) from the gland (6).
- Remove the gland (6).
- Remove old packing (7) and repack with a good grade of $\frac{1}{4}$ " (6mm) square graphited asbestos valve stem packing.
- Install the gland (6) and the hex head capscrews (not shown).
- Install locking flange (3) and hex nuts (5).
- Install woodruff key (20) and valve handle (1).
- To start up the compressor, reverse the shut down procedure in Section 7.2.

O-RING REPLACEMENT (NEW STYLE ONLY)

Refer to Figure 7-13.

- Carry out the shut down procedure in Section 7.2.
- Remove the hex screw and washer (4). Remove the handle (1).
- Remove the four hex screws (5). Remove the diverter cover (3) with o-ring at top of strainer assembly.
- Remove top half of shaft (2) and top diverter plug (7).
- Remove the hex screws (5). Remove the diverter cover (3) with o-ring at bottom of strainer assembly.
- Remove bottom half of shaft (2) and bottom diverter plug (7).
- Replace o-rings (19) on shaft (2) and o-rings (20) at diverter covers (3).
- Install diverter plug (7) onto the bottom shaft (2) and onto the bottom diverter cover (3) and install into strainer assembly.
- Install bottom diverter cover (3) with four hex screws (5) into bottom of strainer assembly.
- Install top shaft (2) onto top of strainer assembly.
- Install top diverter cover (3) with the four hex screws (5) and hex screw and washer (4) onto top of strainer assembly.

⚠ CAUTION

Top shaft must fit over and onto flats of bottom shaft for proper installation. Shaft projections must fit into slots of diverter plugs for proper installation. Bottom diverter plug must fit to bottom diverter cover for proper installation.

- To start up the compressor, reverse the shut down procedure in Section 7.2.

7.11 OIL SEPARATOR ELEMENT SERVICING

Refer to Figure 7-14. On some early packages, this element was not replaceable.

Figure 7-14 Oil Separator Element

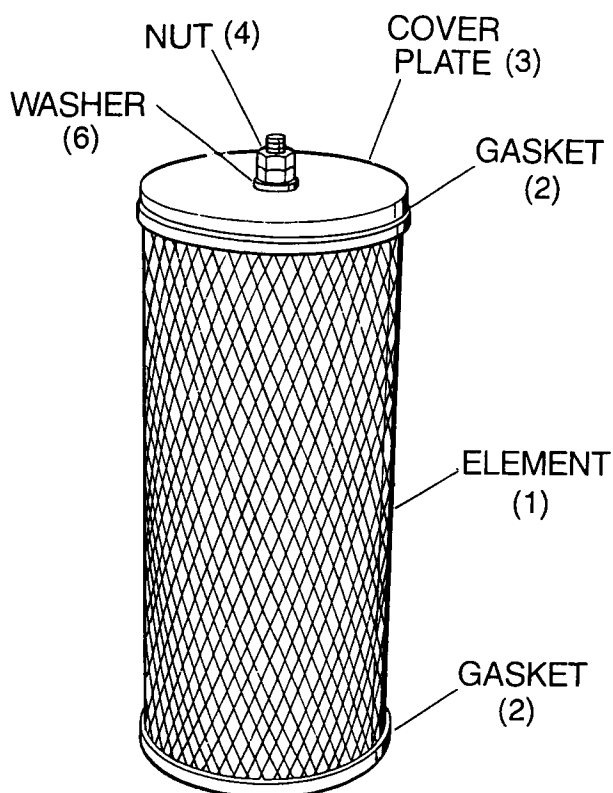

INSPECTION

1. Carry out the shut down procedure as in Section 7.2.
2. Remove access cover on the top of the separator.
3. Inspect the element gaskets (2) for tightness. If the gaskets are blown on either end, they must be replaced. If the gaskets had been replaced recently and they are blown again, the element is dirty and the gaskets and element(s) have to be replaced.

REMOVAL

1. Remove double nut (4), flat washer (6) and cover plate (3).
2. Remove element (1).
3. Scrape old gaskets from both ends of the element if the elements are to be reused.

▲ WARNING

DO NOT clean element screens with air blast or solvents of any kind.

4. Thoroughly clean the gasket surfaces, cover plate and the bulkhead in the separator.

INSTALLATION

1. Cement new gaskets to the element (1) using Loctite 404 (available from Sullair Refrigeration).

2. Replace element (1), cover plate (3), flat washer (6) and double nut (4).
3. Tighten nuts (4) on the cover plate.
4. Replace the access cover on the oil separator using a new gasket if necessary.
5. Close the blowdown valve.
6. Open the suction stop valve slowly to prevent compressor shaft rotation and open the discharge stop valve.
7. If the compressor is liquid injection cooled, open the liquid refrigerant stop valve.
8. If the compressor is fitted with a Sullistage port, open the Sullistage stop valve.
9. Reconnect the control panel to the 115V supply line.
10. Reconnect the starter to the electric supply line.
11. Start the compressor.
12. After compressor comes up to temperature, check and tighten access cover.

7.12 OIL PUMP SERVICING

Refer to Figure 7-15.

REMOVAL

1. Carry out the shut down procedure in Section 7.2.
2. Remove the connecting oil lines on either side of the pump (2).
3. Remove the oil pump by removing the two bolts (8). The pump should come out with the drive hub (4) and connector (5) assembled.
4. If shear pin (6) has broken, remove the adaptor (7) and thoroughly clean out the oil pump area.
5. Use a suitable punch to remove an unbroken shear pin.
6. Inspect all parts for wear and replace if necessary.

INSTALLATION

1. Center-punch the countersunk screws in the oil pump face.
2. Install connector (5) to drive hub (4) using the shear pin (6).
3. Center-punch hub (4) at shear pin hole on both ends to secure the shear pin.
4. Mount the drive hub (4) on the oil pump shaft near the end of the pump shaft. Use care to avoid interference. **DO NOT** tighten the drive hub setscrew (1).
5. Assemble the pump to the compressor adaptor without the o-ring (3). Push-fit by hand until firm to position the drive hub on the shaft.
6. Remove the oil pump taking care not to move the drive hub along the shaft.
7. Move the drive hub (4) $\frac{1}{16}$ inch (1.59 mm) along the shaft towards the oil pump and tighten the drive hub setscrew (1). Check that there is a minimum gap of $\frac{1}{32}$ inch (.79 mm) between the end of the oil pump shaft and the connector (5).
8. Install new o-ring (3).

Section 7 SERVICING

Figure 7-15 Oil Pump Drive Assembly

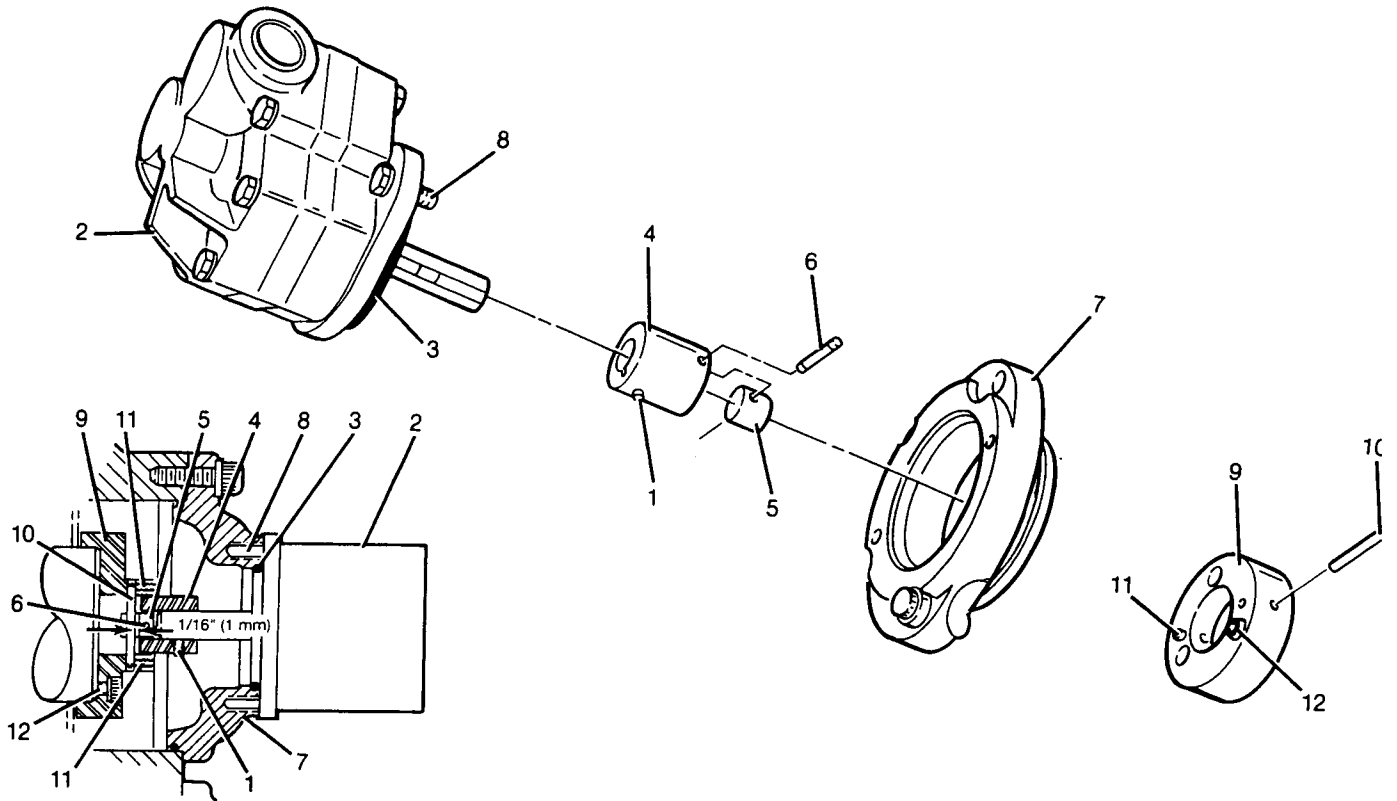

9. Install pump to compressor ensuring the connector (5) engages dowel pin (10) properly.
10. Tighten bolts (8) evenly.
11. Reconnect the oil lines on either side of the pump.
12. Close the blowdown valve.
13. Open the suction stop valve and discharge stop valve.
14. If the compressor is liquid injection cooled, open the liquid refrigerant stop valve.
15. If the compressor is fitted with a Sullistage port, open the Sullistage stop valve.
16. Reconnect the control panel to the 115V supply line.
17. Reconnect the starter to the electric supply line.
18. Start the compressor.

7.13 AUXILIARY OIL PUMP SERVICING

Refer to Figures 7-16 and 7-17.

REMOVAL OF OIL PUMP

1. It is not necessary to shut the compressor down to service the auxiliary oil pump, provided the stop valve before the pump and the check valve after the pump are in good condition. If the valves are not in good condition, or

if there are no valves, carry out the shut down procedure in Section 7.2.

▲ DANGER

DO NOT touch the motor wiring unless the power is disconnected from the oil pump motor.

2. Close the stop valve on the auxiliary pump inlet, if supplied.
3. Remove the connecting oil lines.
4. Remove the three bolts (18) from pump flange.
5. Withdraw the pump from the motor.

REPLACEMENT OF SHAFT SEAL

1. Unscrew the housing plug (10) with its o-ring (9) from the pump housing (6).
2. Remove the steel face (11) and o-ring (12).
3. Remove the seal assembly (13,14,15,16 and 17).
4. Clean the pump shaft (7) and the housing plug (10) with solvent.
5. Inspect the new carbon face and ensure it is clean with no cracks, nicks or scratches. Also check the new steel face for scratches.

Figure 7-16 Auxiliary Oil Pump Servicing

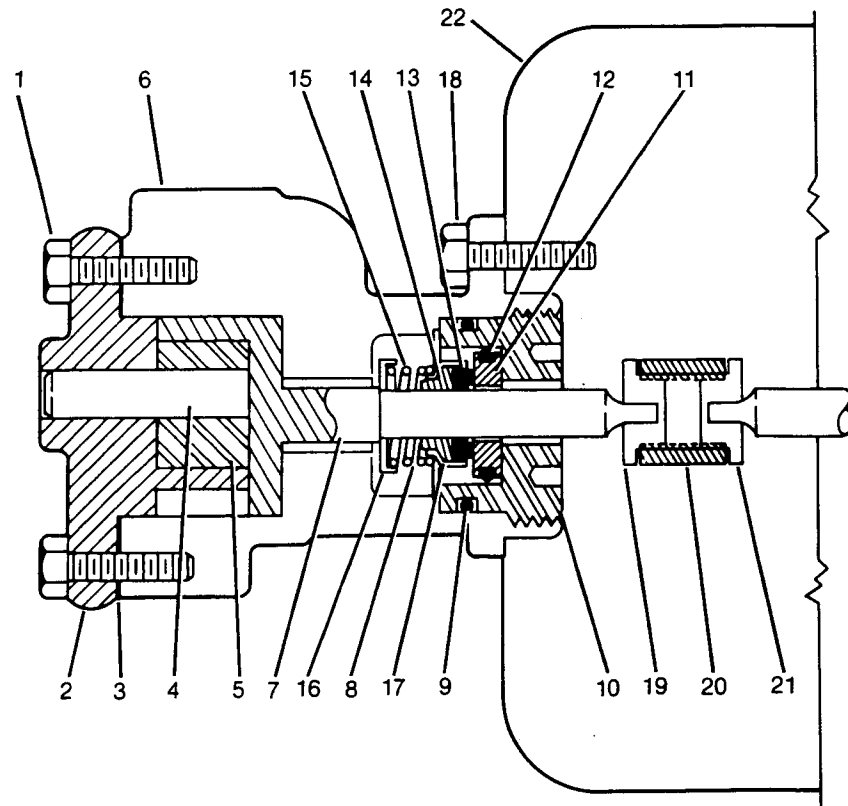

6. Mount the new seal assembly (13,14,15,16 and 17) on the pump shaft.
7. Place a new o-ring (12) on the replacement steel face (11). This may be already mounted on the new face.
8. Immerse the steel face in some clean refrigeration oil.
9. Insert the steel face into the housing plug (10).
10. Mount a new o-ring (9) on the housing plug (10).
11. Screw the housing plug into the pump housing (6).

REPAIR OF OIL PUMP RELIEF VALVE

Refer to Figure 7-17.

1. Remove relief valve cover (1).
2. Back out relief valve adjusting screw (2).
3. Remove valve cap (5), valve cap gasket (6) and inspect relief valve (9) and relief valve spring (8).
4. Inspect relief valve housing.
5. Replace spring (8) and valve (9), cap (5) and gasket (6).
6. Replace adjusting screw (2) and turn in until only enough threads are exposed to allow mounting of the relief valve cover (1).

Figure 7-17 Auxiliary Oil Pump Relief Valve

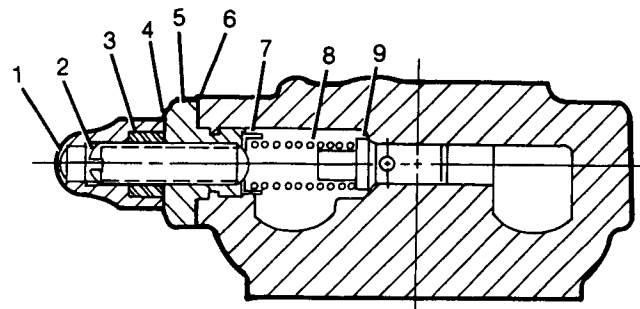

Section 7 SERVICING

7. Replace relief valve cover (1).

INSTALLATION OF THE OIL PUMP

Refer to Figure 7-16.

1. Line up the delrin splined cap (19) on the pump shaft with the centered iron splined coupling (21) and the delrin splined cap (20) on the motor shaft.
2. Mount the oil pump on the motor.
3. Install the mounting bolts (18) into pump flange.
4. Install the connecting oil lines.
5. Open the stop valve on the pump inlet, if supplied.
6. If the compressor was shut down, start up by reversing the shut down procedure in Section 7.2.

7.14 LIQUID INJECTION REGULATING VALVE SERVICING

Refer to Figure 7-18.

A. THERMAL SYSTEM

The thermal system (1A) is a hermetically sealed unit consisting of a sensing bulb, capillary tubing, protective armor and an actuator assembly. This unit contains the thermostatic charge that operates the valve.

The thermal system (1A) can be tested with the valve in place by removing the bulb (1B) from the bulbwell (2B) and placing it in a container which can be heated with hot water or cooled with cold water. Note the bulb working temperature range is normally 80°F to 140°F (27°C to 60°C) and the maximum temperature that the thermal system will withstand without damage caused by a build up of excess pressure is 240°F (116°C). Check the tag on the valve to verify that the range is not different from above.

Observe the valve stem (9Y) while alternatively heating and cooling the bulb. A 10°F (6°C) bulb temperature change at the control temperature will cause the valve to fully stroke. An approximate 5°F (3°C) temperature change from a stable temperature will cause the valve to fully close or fully open the port. If the stem does not move, it is likely that the thermal system has lost its charge or that the valve is locked up. Remove connector assembly (10Y, 11Y and 12Y). Repeat the above thermal system test. If the actuator stem (9Y) moves then the valve may be locked. If the actuator stem does not move, then the thermal system (1A) must be replaced. As the thermal system is hermetically sealed, the thermal system must be replaced with a complete new system.

B. THERMAL SYSTEM REPLACEMENT

The thermal system can be replaced with the valve in place.

1. Stop the compressor with the stop button.

Figure 7-18 Refrigerant Regulating Valve

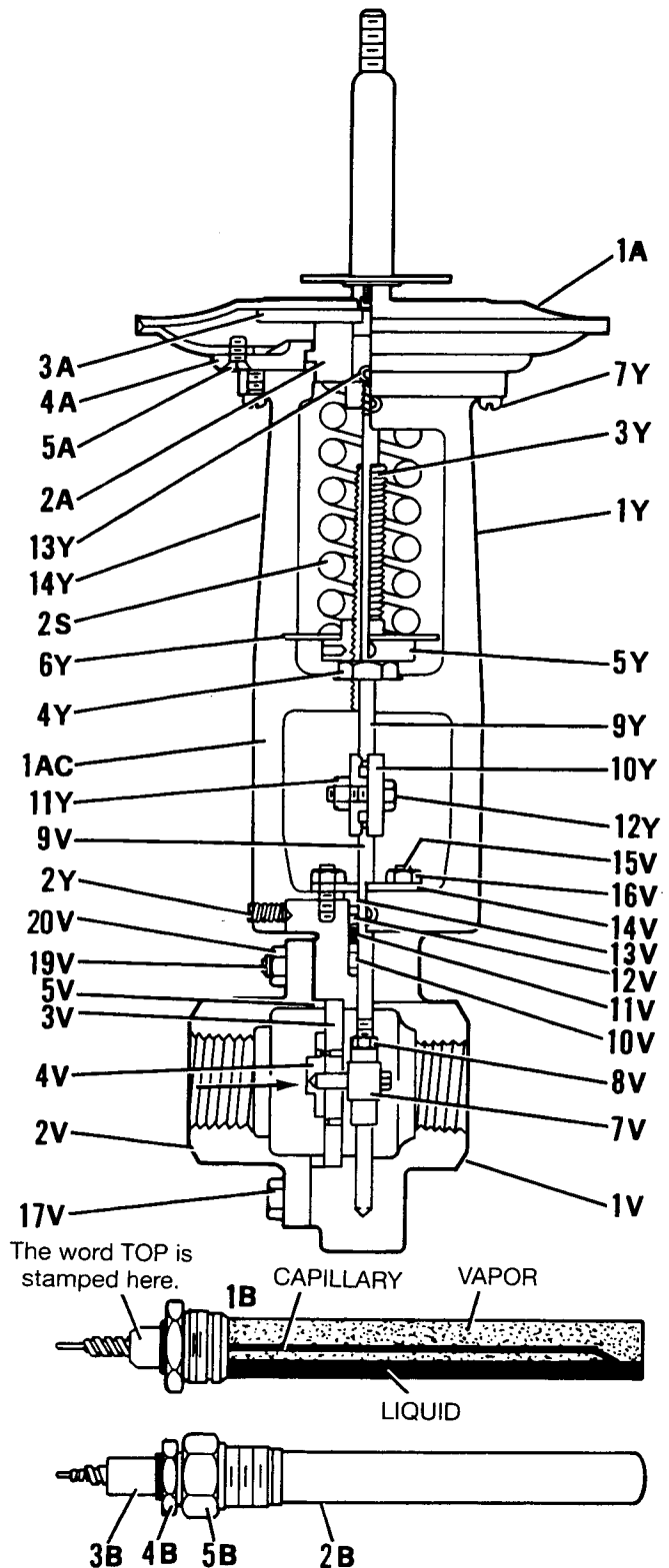

Section 7 SERVICING

2. Turn the start button to the "Manual/Reset" position to prevent the compressor from starting automatically and locking the main motor breaker in the open position.
3. Remove the bulb (1B) from the bulbwell (2B) leaving the bulbwell mounted in the discharge pipe.
4. Remove the thermal system (1A) by rotating the adjusting wheel (5Y) downwards to release the spring compression and remove the four screws (7Y).
5. **DO NOT** remove the adapter plate (4A).
6. To reassemble, place the replacement thermal system onto the valve yoke (1Y) and reinsert the four screws (7Y).
7. Replace connector (10Y) if removed.
8. Coat the bulb (1B) with aluminum paste or grease to improve the heat transfer.
9. Replace the bulb (1B) in the bulbwell (2B), turning the bulb so that the word "top" stamped on the adapter (3B) faces upward.
10. The valve stroke adjustment will not be affected if the above steps have been followed.
11. The compressor can be re-started and the liquid injection valve must be readjusted per Section 5.6; Liquid Injection-Cooled Compressors.

C. REGULATING VALVE ISOLATION

1. Stop the compressor with the stop button.
2. Turn the START button to the "Manual/Reset" position to prevent the compressor from starting automatically.
3. Close the globe valve and the stop valve on either side of the regulating valve.
4. Open the solenoid valve by removing the cap nut at the bottom of the solenoid valve and turn the jacking stem up towards the valve to lift the seat. If this is not done, liquid refrigerant can be trapped between the solenoid valve and the upstream stop valve.
5. Carefully loosen the solenoid strainer cap or a tube fitting to allow liquid refrigerant in the line to boil off.

⚠ WARNING

Be very careful to avoid being sprayed with liquid refrigerant.

6. After all the liquid refrigerant has evaporated, carefully remove the strainer cap. Leave the strainer open to the atmosphere all the time while working on the regulating valve.

D. PACKING REPLACEMENT

The packing can be replaced with the valve and the thermal system in place.

1. Isolate the regulating valve as in (C) above.
2. Remove connector assembly (10Y, 11Y and 12Y).
3. Remove both packing flange nuts (16V).
4. Remove packing flange (14V) and packing follower (13V).
5. Should packing spring (10V) not eject packing set (12V), a slight amount of downstream pressure might be necessary to remove the packing set. Use care to avoid being sprayed by any liquid refrigerant that may be present.
6. Remove packing retainer (11V) and packing spring (10V).
7. Clean packing bore with solvent and blow out thoroughly.
8. Assemble in reverse order and tighten packing flange nuts (16V) so that packing follower (13V) bottoms out on top of valve body (14V).
9. Engage valve stem (9V) and actuator stem (9Y) with connector (10Y). Tighten connector nut and bolt (11Y and 12Y).
10. No stroke adjustment is required.

E. VALVE SEATS DISASSEMBLY

See Table 14 for the standard valve seat Cv sizes. This number is stamped on the outlet side of the seat. Cv is defined as the flow of water in US gallons per minute across the fully opened valve for a pressure drop of 1 PSI.

1. Isolate the regulating valve as in (C) above.
2. Remove the tubing piece upstream from the regulating valve.

TABLE 14

STANDARD REFRIGERANT REGULATOR VALVE SEAT SIZES

HIGH STAGE MODEL	Cv	LOW STAGE MODEL	Cv
C16LA	.42	C16LB	.21
C20SA	.42	C20SB	.21
C20LA	.84	C20LB	.42
C25SA	.84	C25SB	.42
C25MA	.84	C25MB	.42
C25LA	1.6	C25LB	.84
C40LA	2.5	C40LB	.84

Section 7

SERVICING

- Note the scribe line on the side of the valve body (1V) and cap (2V). Remove the capscrews (17V, 20V) and the cap (2V). Note that there is an index pin secured in the valve cap (2V) that fits into the index pin hole in the valve plate (3V). This index pin is on the same side as the scribe line on the valve cap and body and it positions the valve plate in the valve body.

WARNING

The valve seats are lapped to a light band flatness. Maintenance of such tolerances is important for excellent control and tight shut-off. **DO NOT** use metallic objects in removing the seats. Improper handling of the seats will result in leakage and improper control.

- Check the valve disc (4V) for a stamped arrow before removing. This arrow points to the scribed line and the index pin hole in the valve plate. Since the disc can be rotated 180° in some sizes without affecting the stroke adjustment, there may be no arrow on the valve disc. Remove the valve disc.
- Remove the pressure ring (5V).
- Remove the valve plate (3V).

WARNING

DO NOT rotate the disc pin (7V) when disassembling, cleaning, or reassembling, since this affects the stroke adjustment of the valve.

- Clean all the parts of the body and cap with solvent. The valve disc and plate may then be cleaned. If the parts are scarred they must be replaced. **DO NOT** attempt to relap them.
- If no work has to be done on the disc pin, proceed to (H) to reassemble the valve seats.

F. DISC PIN REPLACEMENT

- Isolate the regulating valve as in (C) above.
- Disassemble the valve seats as in (E) above.
- Loosen the stem connector nut (11Y) and bolt (12Y) and remove connector assembly (10Y).
- Back out the four allen head screws (2Y) which will allow the valve body (1V) to be separated from the valve yoke (1Y).
- Loosen the stem locknut (8V) and rotate the disc pin (7V) counterclockwise, pulling the valve stem (9V) upward while doing so. **DO NOT** remove the valve stem completely but raise it sufficiently so that the disc pin may be removed by pulling up and out.
- Replace the disc pin and reassemble in reverse order.
- Adjust the stroke as in (G) below.

G. VALVE STROKE ADJUSTMENT

- Isolate the regulating valve as in (C) above.

- Disassemble the valve seats as in (E) above.
- Stroke the actuator stem (9Y) fully downwards by either loosening the spring (2S) completely and pulling down on the stem or heating the bulb so that the actuator moves the stem downwards.
- Loosen the disc pin locknut (8V) and the stem connector bolt (12Y) and connector nut (11Y).
- Reassemble the valve seats as in (H) below.
- Orifices of the disc (4V) and plate (3V) must align perfectly in the full open position. Adjust the position of the disc on the plate by rotating the valve stem (9V) (clockwise to raise and counterclockwise to lower) until the seats are in the fully opened position. Note the stem will rotate in the stem connector if the connector bolt and nut is loosened slightly. Proper positioning of the valve stem and actuator stem must be maintained during adjustment of the seats.

H. VALVE SEATS REASSEMBLY

- Disassemble the valve seats as in (E) above.
- Place the valve plate (3V) in the body seat recess, ensuring that the index pin hole is on the same side as the scribe line on the valve body. Align the disc pin so that it is centered in the body bore and protrudes through the center slot of the valve plate (3V).
- Place the valve disc (4V) on the valve plate (3V), engaging the disc pin. Be sure that the arrow which is stamped on the disc points to the scribe line on the valve body (1V).
- Note that the pressure ring (5V) has one lapped surface. In replacing the pressure ring, make certain that the lapped surface faces the valve plate (3V).
- Replace the valve cap (2V). Note that the scribe line on the valve cap is aligned with the scribe line on the valve body and the index pin is aligned with the index pin hole in the valve plate. Normally, a slight rotation of the valve cap is sufficient to obtain proper alignment.
- Install the capscrews (17V) and hex nuts (20V) and tighten uniformly diagonally from each other, to a torque of 9 lb./ft. (12 Nm).

I. VALVE INSTALLATION

- Replace and tighten tube and fittings.
- Replace the strainer cap and tighten the cap bolts.
- Return the solenoid valve to automatic operation by turning the jacking stem down away from the valve.
- Coat the bulb (1B) in the bulbwell (2B), turning the bulb so that the word "top" (stamped on the adapter[3B]) faces upward.
- Open the globe valve and the stop valve on either side of the regulating valve.
- Check for refrigerant leaks around the disturbed valve and tubing.
- Adjust the regulating valve per the setting procedure in Section 5.6; Liquid Injection-Cooled Compressors.

Figure 7-19 AC Type Electric Valve Actuator (EVA)

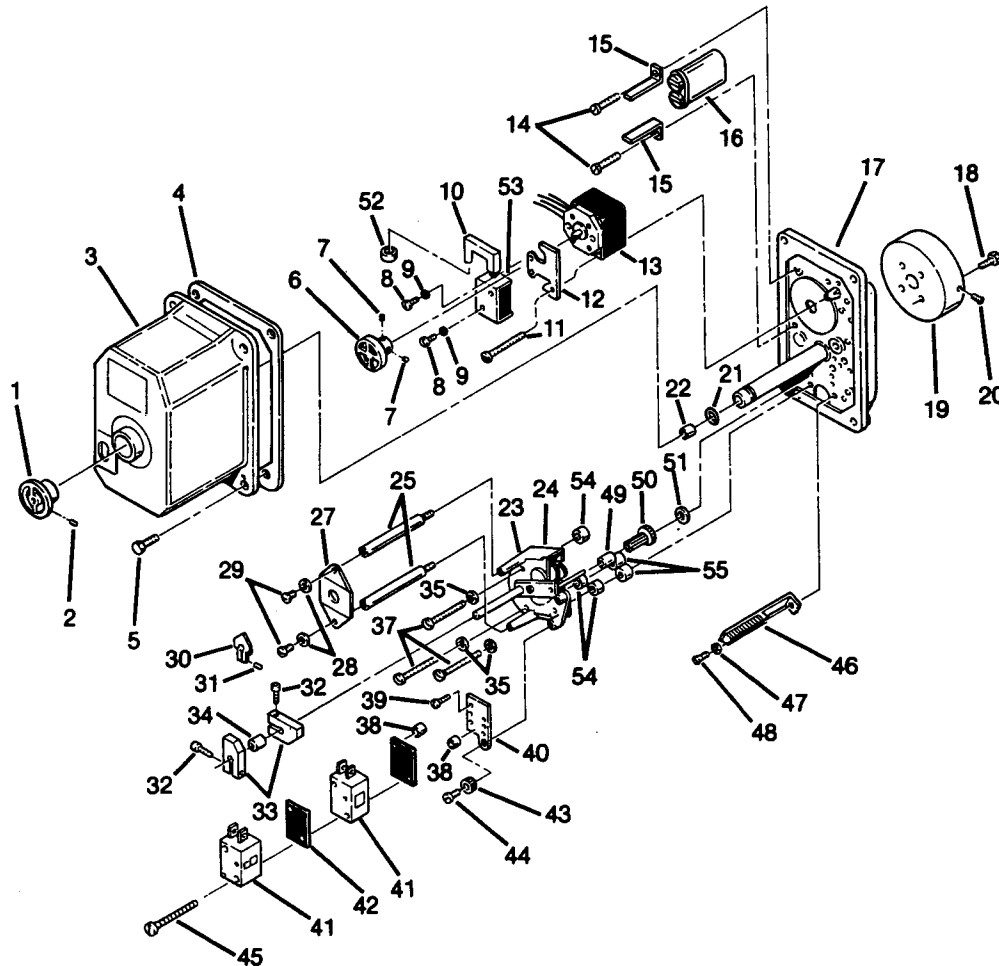

7.15 ELECTRIC VALVE ACTUATOR SERVICING

Refer to Figures 7-19 and 7-20. Since 1981, Sulair has used a new valve actuator. Compare Figures 7-19 and 7-20 to determine which actuator is mounted on your compressor.

AC TYPE ELECTRIC VALVE ACTUATOR (EVA)

Refer to Figure 7-19.

A. INSPECTION

1. Stop the compressor with the stop button on the control panel.
2. Loosen setscrew (2) and remove the manual operation knob (1) and its spacer (22).
3. Remove all four screws (5) and release the EVA cover (3).
4. Inspect visually accessible bearings and gears for wear, proper gear engagement, and check the condition of the solenoid-operated brake (10).

B. REMOVAL AND INSTALLATION OF ELECTRIC MOTOR AND BRAKE ASSEMBLY

1. Disconnect the control panel from the 115V power supply and compressor motor power.
2. Loosen setscrews (7) and remove brake wheel (6).
3. Disconnect electric motor power leads from capacitor (16) and connector strip (46). Note lead connection points and colors. Cut-off plastic wire wraps as needed to free motor leads.
4. Remove all four screws (11) securing the electric motor (13) and the brake assembly mounting bracket (12) to the main gear box (17).
5. If necessary, the brake assembly (10, 12) may now be removed from the electric motor (13) after disconnecting its power leads from the capacitor (16). Note wire connection points and colors, otherwise hold brake assembly

Section 7

SERVICING

aside and pull the electric motor (13) straight out from the main gear box (17).

- Reverse the order of Disassembly Steps and install the electric motor; note that electrical leads shall be retied and routed away from mashing components.

C. REMOVAL AND INSTALLATION OF CAPACITOR

- Loosen screws (14) to release clamps (15) over the edge of capacitor body lip and disconnect power leads; note wire connection points and colors.
- Reverse the order of disassembly steps to install the capacitor.

D. REMOVAL AND INSTALLATION OF LIMIT SWITCHES AND SECONDARY GEAR BOX

- Loosen screws (45) and pull limit switches (41) away from mounting plate (40) and recover spacers (38). If necessary either or both limit switches may be replaced by dismantling switch/gasket sandwich and disconnecting power leads from switch terminals; note lead connection's points and colors.
- Remove screw (39 and 44), adjustment knob (43) and mounting plate (40) from the secondary gear box (24).
- Remove all three screws (37) and pull the secondary gear box (24) straight out from the main gear box (17). Recover spacers (54, 55).
- Loosen setscrew (31) and remove turn indicator (30) from drive shaft on secondary gear box (24).
- Remove screws (29) washers (28) and turn indicator dial plate (27) from extension posts (25).
- Remove extension posts (25) from secondary gear box (24).
- Loosen setscrews (32) and turn limit switch activation cams (33) from drive shaft on secondary gear box (24); recover spacer (34). At this point, no further gear box disassembly is recommended. If wear and tear render the gear box inoperable, replace with a new gear box assembly.
- Reverse the order of disassembly steps to install the secondary gear box and limit switches. To ease the installation of the secondary gear box (24) on the main gear box (17), it is recommended that a small amount of heavy lube grease be applied to gears within secondary gear box (24) to keep them from shifting from the main gear box face and the secondary gear box idler shaft, respectively, during installation. Care must be taken while engaging the idle gear within the gear box against its mating component inside the main gear box (17).

E. REMOVAL AND INSTALLATION OF PRIMARY GEAR BOX

Disassembly of the main gear box (17) is not recommended. If wear and tear render the drive in-

operable, replace complete EVA assembly with a new unit.

F. MULTI-TURN VALVE ACTUATOR LIMIT SWITCH ADJUSTMENT

NOTE

Disconnect 120 Volt power before proceeding.

- Remove manual operation knob (1) and valve actuator cover (3).
- Loosen limit cams (33) located on the multi-turn gearbox assembly cam shaft. A 3/32nds Allen wrench is required.
- Depress actuator brake solenoid (10) to release brake from brake disc (6). With an adjustable wrench, manually turn the output shaft (see main gear box [17]) in a clockwise direction to the mechanical stop of the ball screw assembly. Upon reaching full maximum capacity position (mechanical stop) a slight bind will be felt. **DO NOT OVERTORQUE OR DAMAGE TO THE BALL ASSEMBLY WILL RESULT.**
- Rotate the output shaft one full revolution counterclockwise and set the maximum position cam (33) to activate limit switch (41). The maximum position cam and limit switch pair is located closest to the main gear box (17) connected to the red wire.
- With a felt tip pen or marker, mark the top of the output shaft. This mark is to reference the number of revolutions from maximum to minimum load position (refer to Table 15).
- Table 15 depicts the number of turns from maximum position to minimum based on the compressor model and built-in volume ratio. To determine your compressor model and built-in volume ratio, refer to the nameplate on the compressor control panel.
- Again, manually depress the actuator brake solenoid (10) and rotate the output shaft counterclockwise (unload) per the correct number of revolutions per Table 15 with respect to the mark placed on the output shaft.
- When the correct number of turns is met, set the minimum position cam (33) to actuate limit switch (41). The minimum position cam and limit switch pair is located furthest from main gear box (17), connected to black wire.
- Loosen the turns indicator (30) and set to 0 at a minimum capacity position.

G. REMOVAL AND INSTALLATION OF EVA

If the EVA assembly was removed from the compressor or a new EVA is installed, the following procedure should be followed:

- Mount the assembly to the seal holder (9 in Figure 7-22) making sure that the drive pin (14 in Figure 7-22) is properly engaged in the ball screw shaft.
- Tighten the three set screws (20 in Figure 7-19).

Section 7 SERVICING

Figure 7-20 DC Type Electric Valve Actuator (EVA)

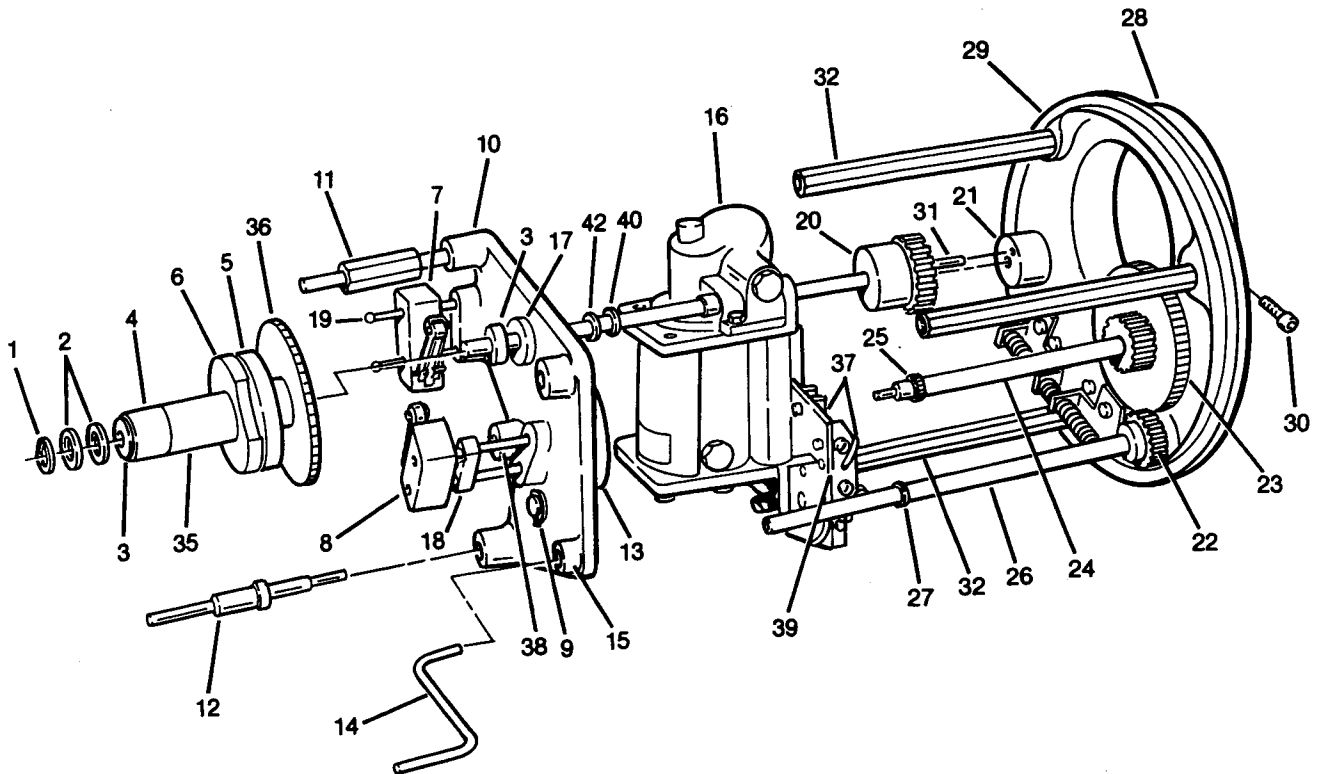

3. If electrical wires were disconnected, reconnect the wires per the appropriate wiring diagram.
4. Reset the limit switches per Section 7.15(F).

D.C. TYPE ELECTRIC VALVE ACTUATOR (EVA)
Refer to Figure 7-20.

A. INSPECTION

1. Stop the compressor with the stop button on the control panel.
2. Remove the three (3) acorn nuts and remove the electric valve actuator cover.
3. Remove the cover o-ring (29).
4. Inspect all bearings and gears for wear and for proper engagement of gears.

TABLE 15

COMPRESSOR MODEL	2.2, 2.6 & 3.7 BUILT-IN VOLUME RATIO (I)	4.8 BUILT-IN VOLUME RATIO (I)
C16L	25	18
C20S	19	14
C20L	30	23
C25S	25	18
C25M	25	18
C25L	38	29
C40L	54	40

(I) Volume Ratio is given in the model number for the package shown on the nameplate on the side of the control panel.

Section 7

SERVICING

B. REMOVAL OF ELECTRIC MOTOR

1. Disconnect the control panel from the 115V power supply.
2. Remove the roller switches (7 and 8) by removing the threaded rod mounts (19). Leave the wires attached to the roller switches.
3. Disconnect the wires to the motor (16). Note the colors of the wires.
4. Disconnect the wires to the torque switches (37) at the switch terminals.
5. Open up the retaining ring (40) on the motor shaft and move the ring along with the flat washer (42) back against the motor.
6. Push the motor shaft through the cam shaft (35) until the front retaining ring (1) can be reached.
7. Remove the front retaining ring (1) and flat washers (2).
8. Slide the camshaft (35) off the motor shaft.
9. Remove the two spacer bolts (11) and the pilot spacer bolt (12).
10. Remove the entire motor package including the bearing plate (10), cams (5, 6), gears (13, 36, 38), slip clutch (20) and torque switches (37). Note the gears (22, 23, 25), crankshaft (26), primary reduction shaft (24) and distance pins (32) remain attached to the motor shaft support (28).
11. Remove the coupling (21) from the end of the EVA motor shaft.
12. Pull the motor shaft out of the bearing plate (10).
13. Remove the rear retaining ring (40) and the flat washer (42).
14. Remove the motor bracket (39) from the motor (16).
15. Drive out the tension pin (8 in Figure 7-21) and remove the first gear and slip clutch assembly (20) from the motor shaft.
16. To service the first gear and slip clutch assembly proceed to (D) below. Otherwise proceed to (G) below.

C. REMOVAL OF FIRST GEAR AND SLIP CLUTCH ASSEMBLY

1. Disconnect the control panel from the 115V power supply.
2. Remove the three acorn nuts and remove the electric valve actuator cover.
3. Remove the cover o-ring (29).
4. Loosen the two socket head capscrews (30) and remove the complete electric valve actuator assembly. The flexible electrical conduit should allow the EVA to be moved enough without disconnecting the conduit.
5. Drive out the tension pin (8 in Figure 7-21) and remove the first gear and slip clutch assembly (20) from the motor shaft.

D. DISASSEMBLY OF FIRST GEAR AND SLIP CLUTCH ASSEMBLY

Refer to Figure 7-21.

1. Remove the first gear and slip clutch assembly as in (C) above. Alternatively remove the first

Figure 7-21 First Gear and Slip Clutch Assembly

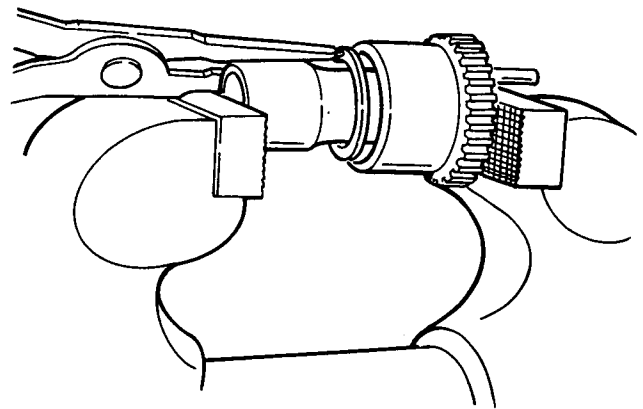

A

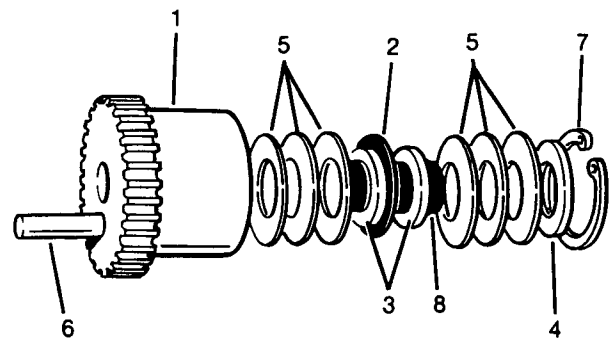

B

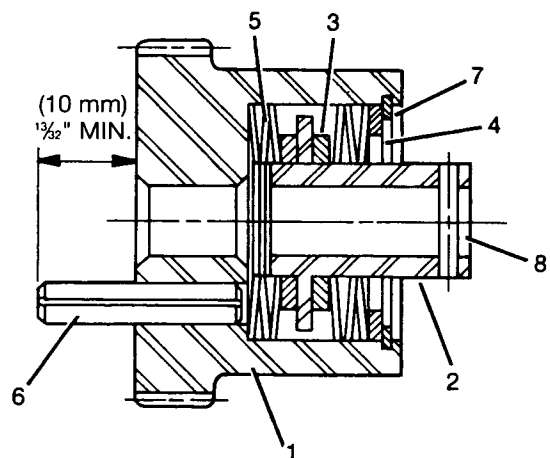

C

gear and slip clutch assembly in addition to the electric motor as in (B) above.

2. Insert a sleeve (e.g. 1-1/2" 12 point, thin wall socket) over the end of the coupling half (2) and clamp the entire assembly in a vise (shown in A). Tighten the vise enough to remove the tension against the internal snap ring.
3. Remove the internal snap ring (7).
4. Release the vise tension slowly.
5. Clean all internal components in solvent and inspect them for abnormal wear.
6. Replace the parts as necessary.

E. REASSEMBLY OF FIRST GEAR AND SLIP CLUTCH ASSEMBLY

Refer to Figure 7-21.

1. Disassemble the first gear and slip clutch as in (D) above.
2. Coat all internal components with light machine oil. Apply a liberal coat of molybdenum disulfide grease (e.g. Dow Corning Molykote "G") to both surfaces of all friction discs (3).
3. Reassemble the slip clutch in the order shown in Figure 7-21.

▲ WARNING

Make certain the spring washers (5) are oriented as shown in Figure 7-21. When correct, the outer face of the washer (4) will be flush with the face of the first gear (1) prior to inserting the internal snap ring (7). If not correct, disassemble and recheck the orientation of the spring washers (5). If necessary, replace the spring washers.

4. Insert the sleeve over the coupling half (2) and clamp the assembly in a vise (shown in A). Apply enough tension to compress the spring washers far enough to insert the internal snap ring (7).
5. Insert the internal snap ring. Make sure the snap ring is properly seated and release the vise tension slowly.

F. INSTALLATION OF FIRST GEAR AND SLIP CLUTCH ASSEMBLY

Refer to Figure 7-20.

1. If the electric motor was also removed (as in (B) above), proceed to (G) below to install the first gear and slip clutch assembly.
2. Slide the first gear and slip clutch assembly onto the motor shaft such that the shaft protrudes approximately 1/4" (6mm) past the face of the gear. Line up the hole in the coupling half of the first gear and slip clutch assembly with the hole in the motor shaft.
3. Insert the tension pin (8 in Figure 7-21) to secure the first gear and slip clutch assembly to the motor shaft.

4. Replace the coupling (21 in Figure 7-20) on the end of the EVA motor shaft and engage the tension pin (31 in Figure 7-20).
5. Mount the electric valve actuator using care to align the pin (14 in Figure 7-22) in the coupling (13 in Figure 7-22) with the slot in the end of the ball screw shaft.
6. Install the two socket head capscrews (30) to secure the EVA assembly to the compressor unit.
7. Adjust the electric valve actuator cams etc. as in (H) below.

G. INSTALLATION OF ELECTRIC MOTOR

1. Slide the first gear and slip clutch assembly (20) onto the motor shaft such that the shaft protrudes approximately 1/4" (6mm) past the face of the gear. Line up the hole in the coupling half of the first gear and clutch with the hole in the motor shaft.
2. Insert the tension pin (8 in Figure 7-21) to secure the first gear and slip clutch assembly to the motor shaft.
3. Mount the switch bracket (39) to the motor.
4. Place the rear retaining ring (40) and washer (42) on the motor shaft next to the motor.
5. Insert the motor shaft through the bearing plate (10).
6. Place the coupling (21) on the end of the EVA motor shaft.
7. Mount the motor package to the bearing plate (10) using care to align the pin in the coupling with the slot in the end of the ball screw shaft.
8. Install the three spacer bolts (11, 12).
9. Mount the cam shaft (35) on the end of the motor shaft.
10. Replace the front retaining ring (1) and two washers (2) on the motor shaft.
11. Slide the motor shaft back into place towards the compressor.
12. Slide the rear retaining ring (40) and shim washer (42) into place against the bearing plate.
13. Be sure that the fifth and sixth gears (36, 38) mesh properly. If they do not, the end play is too great and additional shim washers should be placed before the front retaining ring on the motor shaft.
14. Connect the wires to the torque switches (37) at the switch terminals.
15. Reconnect the wires to the motor making sure the wires are the same color as those taken off when removing the motor.
16. Mount the roller switches (7, 8).
17. Check that the EVA motor is mounted on the compressor in the vertical position for proper torque switch operation. The line between the motor shaft centerline and the bottom space bolt should be vertical.

H. ADJUSTMENT OF ELECTRIC VALVE ACTUATOR

Refer to Figure 7-20.

Section 7

SERVICING

1. Carry out the inspection procedure as in (A) above.
2. Check to see that all gears are aligned properly. Adjust the axial position of a gear by loosening the setscrew in the gear hub.
3. Move the capacity control slide valve to the maximum (or fully closed or fully loaded) position by turning the hand crank (14) on the capacity control actuator clockwise until it stops at the maximum position stop.
4. Turn the hand crank counterclockwise to rotate the first gear and slip clutch assembly (20) 1½ revolutions counterclockwise back from the maximum position stop.
5. Mark the hub on the first gear and slip clutch assembly (20) with a pencil or a felt pen.
6. If the maximum position cam (6) is loose on the camshaft or is suspected of having moved relative to the camshaft, carry out Steps 7, 8 and 9. Otherwise carry out Steps 10, 11, 12, 13, and 14.
7. Loosen the setscrew on the maximum position cam (6) (the second cam away from the compressor) with an Allen wrench.
8. Rotate the maximum position cam (6) clockwise on the shaft until the roller switch (8) just opens. Listen for a click or check electrical continuity with an ohmmeter.
9. Tighten the setscrew in the maximum position cam very tightly to prevent loosening. The capacity decal (4) on the end of the camshaft should read maximum in the vertical up position.
10. Loosen the hex nut (9).
11. Disengage the variable ratio gear (38) from the sixth gear (36).
12. Rotate the sixth gear and the camshaft so the capacity decal reads maximum in the vertical up position.
13. Re-engage the variable ratio gear (38) with the sixth gear (36).
14. Tighten the hex nut (9).
15. Move the capacity control slide valve to the minimum for fully open or fully unloaded position by turning the hand crank counterclockwise to rotate the first gear and slip clutch assembly counterclockwise the number of revolutions given in Table 15 above.
16. Loosen the setscrew on the minimum position cam (5) (the cam nearest the compressor) with an Allen wrench.
17. Rotate the minimum position cam (5) counterclockwise on the shaft until the roller switch (7) just opens. Listen for a click or check electrical conduits with an ohmmeter.
18. Tighten the setscrew in the minimum position cam (5) very tightly to prevent loosening.
19. Check that the roller switches touch only their respective cams.
20. Reconnect the control panel to the 115V supply line.
21. Check the above adjustments with power to the electric valve actuator as in Section 4.16.
22. Replace the EVA cover o-ring (29).
23. Mount the EVA cover and install the three acorn nuts.
24. Start the compressor.

I. REMOVAL AND INSTALLATION OF EVA

If the EVA assembly was removed from the compressor or a new EVA is installed, the following procedure should be followed:

1. Mount the assembly to the seal holder (9 in Figure 7-22) making sure that the drive pin (14 in Figure 7-22) is properly engaged in the ball screw shaft.
2. Tighten the three set screws (Figure 7-20).
3. If electrical wires were disconnected, reconnect the wires per the appropriate wiring diagram.
4. Reset the limit switches per Section 7.15(H).

7.16 CAPACITY CONTROL SHAFT SEAL SERVICING

Refer to Figure 7-22.

REMOVAL

1. Carry out the shut down procedure in Section 7.2.
2. Remove the EVA per Section 7.15(I).
3. Remove the three capscrews (10) from the seal holder (9).
4. Withdraw the seal holder, using care to prevent scratching the seal lip on the shaft.
5. Remove the two seals (15) from the seal holder.
6. Examine the seals for wear, cracks and deformities in the sealing lips.

INSTALLATION

1. Remove any burrs from the seal holder (9).
2. Smear thread sealer on the outside diameters of the seals (15) to prevent leakage. Be sure to place the seals back to back as shown in Figure 7-22 so they will seal against either a positive pressure or a vacuum. Press the new seals (15) into the seal holder (9) using care not to deform or bend the seals.
3. Check to see that the shaft is clean and free from burrs to prevent damage to the seals.
4. Replace the o-ring (16) in the seal holder (9) groove.
5. Mount the seal holder over the shaft and push into place, taking care not to damage the sealing lips.

WARNING

Table 15 shows the correct number of revolutions of the first gear and slip clutch assembly for the system to move the capacity control slide valve from maximum to minimum position. DO NOT exceed this number for correct unloaded operation. Note these revolutions are not the number of revolutions of the hand crank. Note the capacity decal may or may not read minimum at this point. The same decal is used on all models regardless of the number of turns from maximum to minimum.

Figure 7-22 Capacity Control Shaft Seals and Pilot Valve Assembly

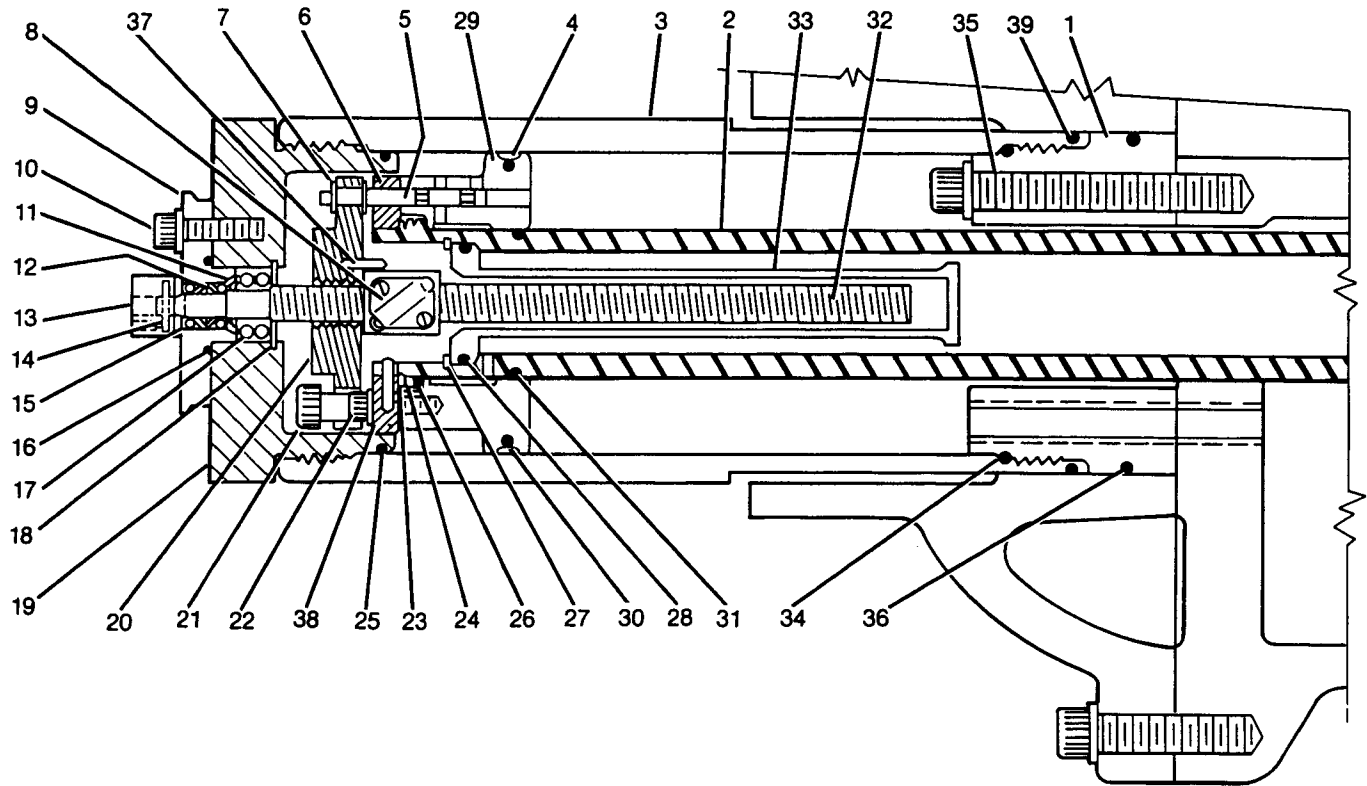

6. Tighten the three cap screws (10).
7. Close the blowdown valve.
8. Replace the EVA per Section 7.15(G) or 7.15(I).
9. Open the suction stop valve and discharge stop valve.
10. Check the region of the replaced seals for leaks.
11. If the compressor is liquid injection-cooled, open the liquid refrigerant stop valve.
12. If the compressor is fitted with a Sullistage port, open the Sullistage stop valve.
13. Reconnect the control panel to the 115V supply line.
14. Operate the EVA manually to check its operation as in Section 4.16. If the limit switches do not stop the motor at the minimum or maximum position, the cams must be reset as in Section 7.14 (AC - F and DC - H).
15. Reconnect the starter to the power supply.
16. Start the compressor.

7.17 CAPACITY CONTROL PILOT VALVE ASSEMBLY
Refer to Figure 7-22.

A. REMOVAL OF PILOT VALVE ASSEMBLY

1. Carry out the shutdown procedure in Section 7.2.
2. Check that the capacity control valve has returned to the minimum or fully unloaded position on shut down by examining the decal on the end of the electric valve actuator. This moves the pilot valve assembly away from the end cover (19), which is a requirement for Step 10 below.
3. Loosen the 2 or 3 socket head cap screws (20 in Figure 7-19 or 30 in Figure 7-20), and remove the EVA. The flexible electrical conduit should allow the EVA to be moved out of the way without disconnecting the conduit.
4. Remove the three cap screws (10) from the seal holder (9).
5. Withdraw the seal holder using care to prevent scratching the sealing lips on the shaft.
6. Examine the sealing lips for wear, cracks and deformities and if necessary replace the seals as in Section 7.16.
7. Insert two $\frac{3}{8}$ "-16 UNC 2 inch long screws into the tapped holes for the cap screws (10).

Section 7

SERVICING

8. Use a bar between the capscrews and unscrew the end cover (19) from the capacity control cylinder (3). Use care not to damage the ball screw shaft.
9. When the end cover (19) is loose from the capacity control cylinder, pull the end cover by hand away from the compressor. The pilot valve assembly, consisting of valve plate (20), pilot valve (5), piston (29) and ball nut (8) is pulled toward the maximum or fully loaded position in the end of the hydraulic cylinder by the ball screw (which is attached at one end to the ball nut and at the other end to the end cover). Pull the end cover far enough for access to the three shoulder screws (21) on the valve plate (20) or until the piston comes to a stop against the retaining ring (23) attached to the hydraulic cylinder (2).
10. Remove the three shoulder screws (21) with an Allen wrench, using care not to bend or damage the pilot valve (5) connected to the valve plate (20).
11. With the valve plate and pilot valve loose from the piston, remove the end cover (19) and ball screw complete with the subassembly of valve plate, pilot valve and ball nut. The piston (29) and locating plate (6) will remain behind in the end of the cylinder.
12. Remove the o-ring (25) from the end cover.

B. DISASSEMBLY OF PILOT VALVE ASSEMBLY

1. Remove the snap ring (18).
2. Remove the ball screw (32) with attached bearing (17) from the end cover (19). Support the end cover on wooden supports with the ball screw hanging down and tap the end of a screwdriver inserted into the end slot of the ball screw.
3. Remove the retaining snap ring (12) and support ring (11) from the ball screw.
4. Remove the bearing (17) from the ball screw by supporting the outer race and lightly hitting the end of the shaft.
5. Remove the E-rings (7) from the pilot valve (5).
6. Remove the pilot valve from the valve plate (20).
7. Remove the roll pin (37) from the valve plate.
8. Unscrew the valve plate from the ball nut.

WARNING

DO NOT attempt to unscrew the ball screw shaft from the ball nut.

9. If it is not required to remove the hydraulic cylinder and piston, proceed to (E) below.

C. REMOVAL OF HYDRAULIC CYLINDER AND PISTON

1. Remove the pilot valve assembly as in (A) above.

2. Loosen the cylinder (3) by turning it counter-clockwise with a strap wrench. Remove it carefully.
3. Remove the slide ring (4) and back up o-ring (30) from the piston (29).
4. Remove the three screws (22) holding the locating plate (6) to the piston (29).
5. Remove the locating plate (6).
6. Remove the internal retaining snap ring (23).
7. Slide the piston off the capacity control valve rod (2). The piston rod shim (24) and the o-ring (26) behind the retaining ring will be pushed out by the piston.
8. Remove the o-ring (31) from the piston rod (2).

D. INSTALLATION OF HYDRAULIC CYLINDER AND PISTON

1. Clean and inspect all the parts and replace as necessary. Examine the hydraulic cylinder for any unevenness in the sliding surface.
2. Mount a new o-ring (31) on the piston rod (2).
3. Mount the piston (29) on the piston rod.
4. Install a new o-ring (26), piston rod shim (24) and retaining ring (23).
5. Mount the piston locating plate (6) on the piston with the roll pin (38) in the end slot at the bottom of the piston rod.
6. Install and tighten the three screws (22) holding the locating plate to the piston. Use Loctite 242 on the screw threads.
7. Mount a new o-ring (30) and slide ring (4) on the piston (29). Lightly oil the o-ring and adjacent surfaces.
8. On C25 compressors only, install a new o-ring (39) on the cylinder (3). Lightly oil the o-ring.
9. Screw the cylinder (3) into place using care not to scratch or cut the slide ring (4).

E. ASSEMBLY OF PILOT VALVE

1. Clean and examine the ball screw (32) for wear (including the end slot) and if necessary replace both the ball screw and ball nut (8).
2. Clean and examine the remaining parts and replace as necessary.
3. Screw the valve plate (20) onto the ballnut (8).
4. Drill a hole $\frac{3}{16}$ " diameter, $\frac{1}{4}$ " deep in the valve plate adjacent to the ball nut and insert a roll pin (37) to prevent the ball nut, rotating and unscrewing from the valve plate.
5. Mount the pilot valve (5) in the valve plate.
6. Secure the pilot valve with E-rings (7) on either side of the valve plate.
7. Install the bearing (17) on the ball screw shaft. A light press is required on the bearing inner race.
8. Lock the bearing on the shaft with a support ring (11) and a retaining snap ring (12).
9. Install the bearing into the end cover (19) with a light press fit.
10. Secure the bearing with the retaining snap ring (18).

Section 7 SERVICING

F. INSTALLATION OF PILOT VALVE ASSEMBLY

1. Mount a new o-ring (25) on the end cover (19).
2. Insert the pilot valve (5) through the locating plate (6) into its bore in the piston and mount the valve plate (20) to the piston.
3. Install the three shoulder screws (21), using care not to bend or damage the pilot valve (5). Use Loctite 242 on the screw threads.
4. Screw the end cover (19) into the hydraulic cylinder.
5. Tighten the end cover (19) with a bar between the two $\frac{3}{8}$ "-16 UNC 2" long screws inserted into the tapped holes for the capscrews (10). Use care not to damage the ball screw shaft.
6. Mount the seal cover (9) complete with the two back to back seals (15) and the o-ring (16) as in section 6.15.
7. Mount the electric valve actuator as in Section 7.15(G) or 7.15(I).
8. Jumper the low oil pressure switch.
9. With the main motor power disconnected, and the control panel energized to simulate operations, check the electric valve actuator switch settings as in Section 4.16.
10. Close the blowdown valve.
11. Open the suction stop valve and discharge stop valve.
12. Remove the jumper from the low oil pressure switch.
13. If the compressor is liquid injection-cooled, open the liquid refrigerant stop valve.
14. If the compressor is fitted with a Sullistage port, open the Sullistage stop valve.
15. Reconnect the control panel to the 115V supply line.
16. Reconnect the starter to the electric supply line.
17. Start the compressor.

7.19 ROTOR END PLAY INSPECTION

The condition of the thrust bearing can be determined by a vibration log or by measuring the actual movement of the rotors when a predetermined force is applied to the end of each shaft.

7.20 VIBRATION LOG

If equipment is available for measuring and charting vibration velocities, a vibration log is the better method of observing the condition of the compressor.

Because of the many types of vibration monitoring equipment used by industry, only broad guidelines can be given regarding its use.

Before any data is taken and evaluated, it is absolutely necessary to acquire a thorough understanding of the equipment's limitations.

To determine a compressor's conditions from its vibration requires that the vibration be measured at several carefully selected points and directions and that the signal be analyzed into the basic

7.18 SUCTION CHECK VALVE REPLACEMENT

1. Carry out the shut down procedure in Section 7.2.
2. Remove the insulation from the check valve.
3. Remove the check valve flange bolts.
4. With a come-along or light crane, take the weight of the suction line off the check valve.
5. Remove the check valve.

TABLE 16
COMPRESSOR VIBRATION LIMITS

COMPRESSOR MODEL	VIBRATION RANGES							
	NORMAL		ACCEPTABLE		ABNORMAL		SHUTDOWN	
	in./sec.	mm/sec.	in./sec.	mm/sec.	in./sec.	mm/sec.	in./sec.	mm/sec.
C16L	<.23	<5.84	.23◇.37	5.84◇9.40	.37◇.58	9.40◇14.7	>.58	>14.7
C20S,L	<.25	<6.35	.25◇.39	6.35◇9.91	.39◇.62	9.91◇15.75	>.62	>15.75
C25S,M,L	<.26	<6.60	.42◇.66	10.67◇16.76	.42◇.66	10.67◇16.76	>.66	>16.76
C40L	<.30	<7.62	.30◇.48	7.62◇12.19	.48◇.75	12.19◇19.05	>.75	>19.05

Section 7

SERVICING

components that make up the complex, raw waveform.

A common method for judging vibration severity is to establish baseline signatures for a compressor known to be in good operating condition and to monitor changes in those signatures with time.

It is important that vibration data always be taken at the same points and load conditions, preferably full load and same operating conditions. It must also be realized that so called "identical" compressors will generate their own unique signatures. Attention should be paid to those frequencies that can be identified with a source and with changes in the overall signature with time.

The type and location of vibration transducers is based on the specific compressor and range of characteristics to be monitored. One important thing to remember when locating transducers is that they not only measure the effect of the forces transmitted through the structure, but also the mobility of the structure at the point of measurement. In other words: a combination of high force and low mobility at a given frequency will result in a suppressed vibration peak. Our type of compressor which generates a wide range of frequencies requires a sensor with broad dynamic ranges and frequency response (approximately 10–1000Hz for direct driven compressors).

The low casing-to-rotor weight ratio and the anti-friction bearings, which severely limit relative motion between shafts and casing, cause most of the linear dynamic force developed by the rotors to be transmitted into the structure where it is dissipated as casing motion. This will permit a casing mounted accelerometer to collect representative health characteristics within the frequencies of interest.

On the other hand, a large sleeve bearing motor with a high casing-to-rotor weight ratio and little meaningful high frequency activity are generally monitored most effectively with shaft displacement procedures.

Generally speaking, the proportion of total dynamic force contributed by the displacement velocity and acceleration terms will change with frequency, which means that displacement dominates at the low end of the frequency band and acceleration becomes important at very high frequencies. For our type of machinery which generates important frequencies somewhere in the middle of the band, velocity measurements are recommended. Another important reason is that velocity measurements generally will give the flattest spectrum in the frequency range of interest.

Many methods are used and are under continuous development to deal with complex vibration spectra: statistical analysis, demodulating techniques, spectral alarm band specifications, track-

ing order analysis, ultrasonic analysis for early detection of anti-friction bearing flaws, etc. These methods plus torsional vibration analysis are too complex to adequately cover in this manual.

When taking a set of readings, the following steps should be followed:

1. Load compressor to maximum position by shutting additional compressors off.
2. Record a complete set of operating conditions as in Table 9.
3. Make a strip chart recording in the horizontal, vertical and axial positions on the compressor and motor. Vibration probe must be mounted as shown in Figures 7-23, 7-24, 7-25, and 7-26.
4. If any readings have changed or exceed the limits in Table 16, shut the compressor down and check motor alignment per Section 4.10.
5. If, after motor alignment, vibration is still in the abnormal range, then a physical end play check and possibly a check of the capacity control valve guides should be made. A physical end play check cannot be performed on a C40L due to bearing design.

7.21 ROTOR END PLAY MEASUREMENT SPRING LOADED BEARINGS (Except C40)

Since approximately September, 1988, Sullair has supplied the C16, C20 and C25 compressors with spring loaded thrust bearings. These thrust bearings are designed to maintain a preload on the bearings at all times. Rotor end play inspection should be performed per Section 7-22.

If both readings are less than 0.003 inches (0.0762mm), the bearings will be in acceptable condition. If either reading is greater than 0.003 inches (0.0762mm), contact the Sullair Refrigeration Service Department after taking readings on both rotors. The Service Department will have to have the compressor serial number 006-XXXXXXXXXX or 007-XXXXXXXXXX With this serial number, they will check the assembly records for the discharge end clearance which was set at the factory. If the end play is 0.001 inches (0.0254mm) less than the factory set end clearance, the compressor can continue to run, but replacement may be required in the near future. If bearings have been changed in the field, then the set discharge end clearance must be recorded and compared to the end play, as the factory set will no longer be valid.

ROTOR END PLAY MEASUREMENT NON-SPRING LOADED BEARINGS (Except C40)

Before approximately September, 1988, Sullair supplied the C16, C20 and C25 compressors with thrust bearings (pre-loaded). A smaller end play with these bearings could allow skidding of the balls in the unloaded bearing thus resulting in bearing failure. When doing an end play, check on a compressor which has these pre-loaded bearings; a force must be applied which will only

Figure 7-23 Vibration Probe Locations - Discharge End

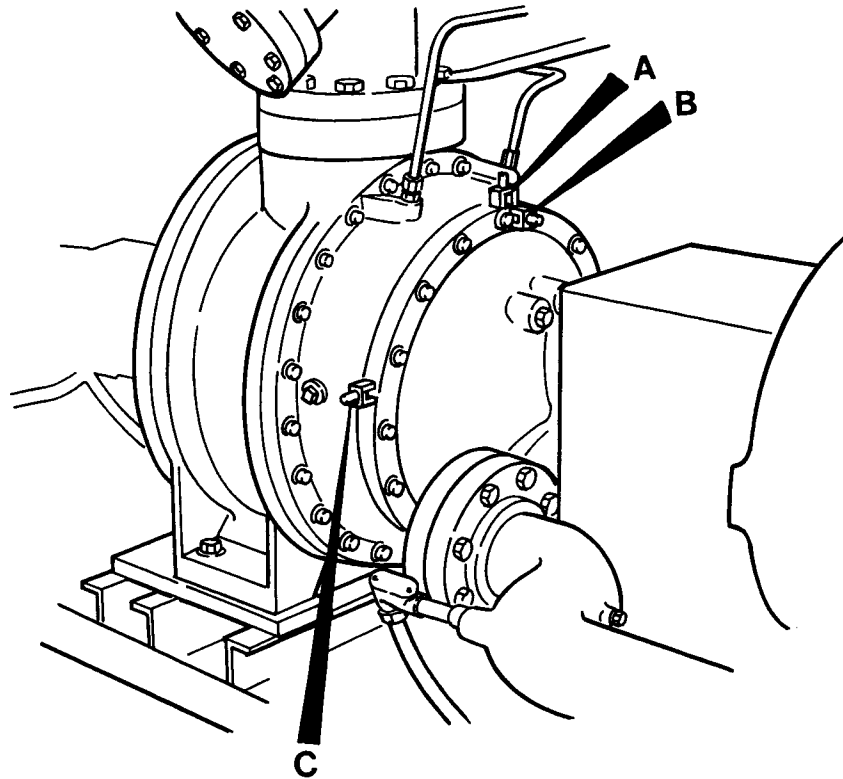
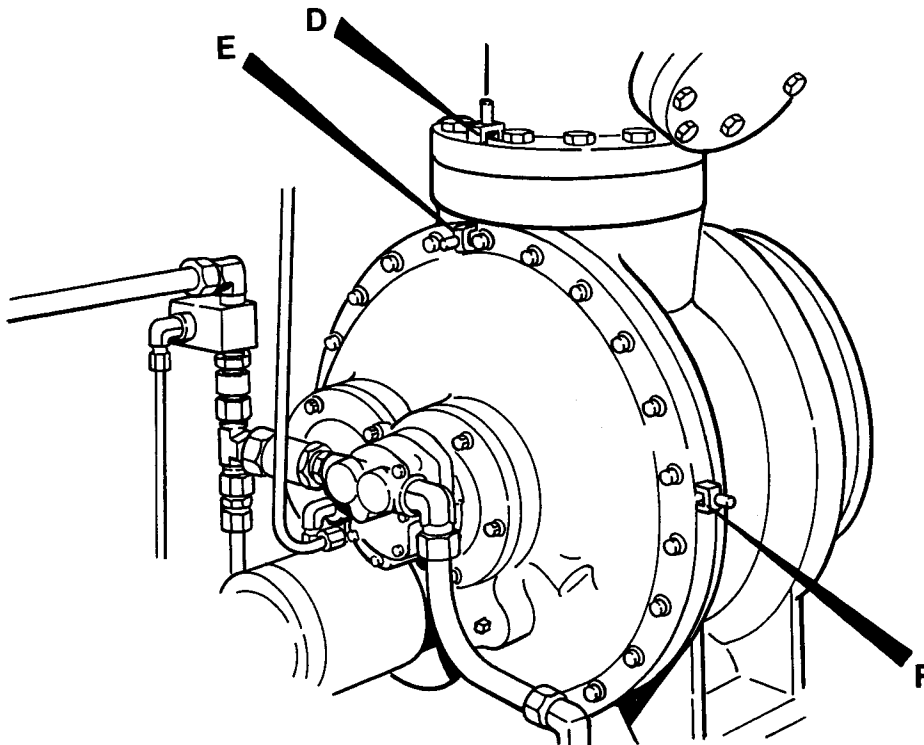

Figure 7-24 Vibration Probe Locations - Inlet End



Section 7
SERVICING

Figure 7-25 Vibration Probe Locations – Drive End of Motor

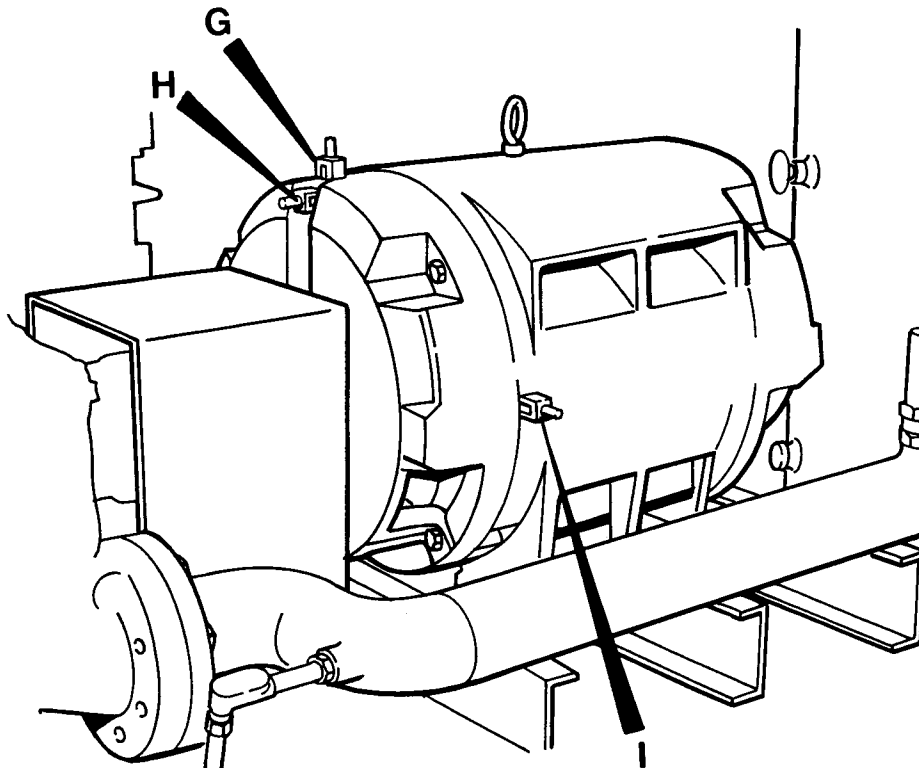

Figure 7-26 Vibration Probe Locations – Drive End of Motor

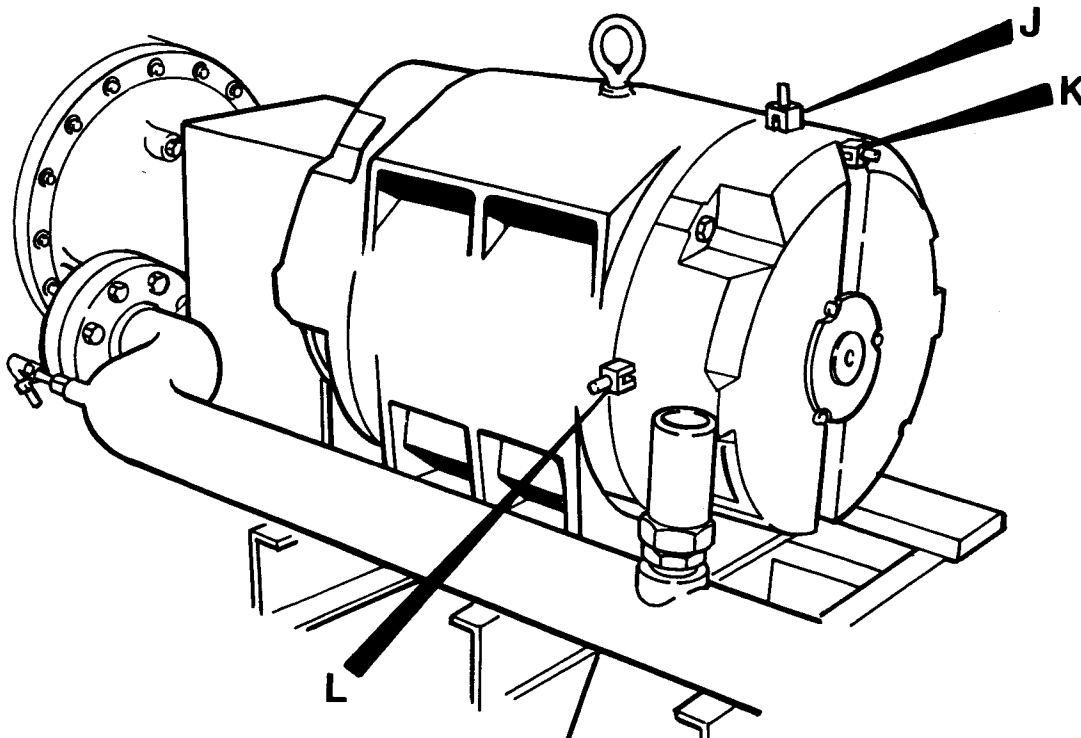
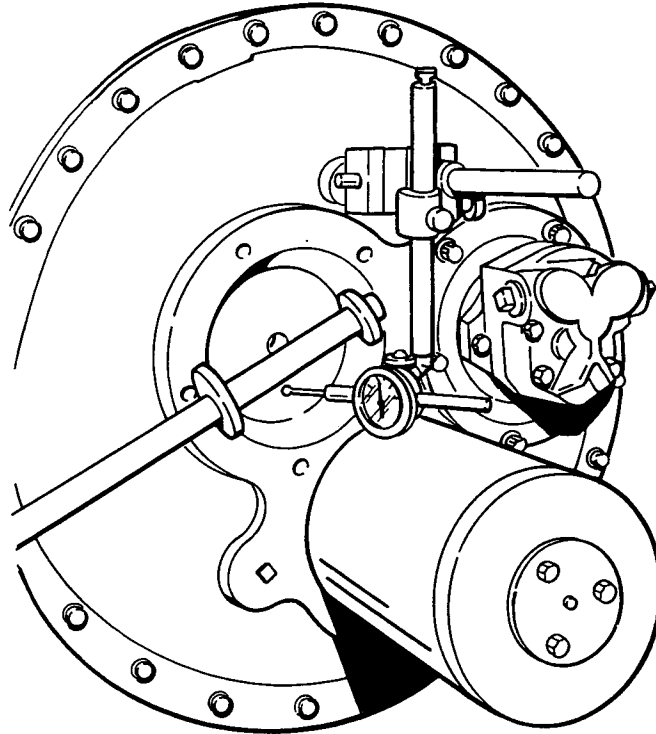

Figure 7-27 Measurement of Rotor End Play



move the rotors and reset the bearing balls and races. The allowable end plays for these bearings are listed in Table 17.

7.22 ROTOR END PLAY INSPECTION PROCEDURE (Except C40L)

1. Carry out the shutdown procedure listed in Section 7.2.
2. Remove the connection piping around the oil pump.
3. Referring to Section 7.13 and Figure 7-15, remove the oil pump by removing the two bolts (8). The pump should come out with the drive hub (4) and connector (5) assembled.
4. Again referring to Figure 7-15, remove the adapter (7). Use a screwdriver to part the adapter from the inlet housing.
5. Referring to Figure 7-27, remove the male rotor inlet bearing cover. Use a screwdriver to part the cover from the inlet housing.
6. Remove one of the three screws (12 in Figure 7-15) holding the oil pump drive disc (9 in Figure 7-15) or the balance piston (Figure 7-27).
7. Install an eye bolt per Table 18 in place of this screw.
8. Install a second eye bolt per Table 18 into the inlet housing.
9. Using a magnetic base mounted to the inlet housing flange, mount a dial indicator touching the end of the male rotor or the oil pump disc on the female rotor, depending on which rotor is being checked.
10. Set the dial indicator reading to zero.
11. With a $\frac{3}{4}$ " (19mm) diameter by 1 foot (305mm) long bar placed through both eye bolts, and by using the eye bolt in the inlet housing as a fulcrum, apply hand force (approximately 50 pounds (220N) using a back and forth movement to create end play (see Figure 7-27 for a typical set-up).
12. Read the end play movement on the dial indicator when the hand force is applied and held in both directions.
13. Compare the rotor end play with the tolerances in Table 17 or Section 7.21; Rotor End Play Measurement Spring Loaded Bearing.
14. After one rotor is checked, follow the same procedure for the second rotor.
15. Reassemble the parts with new gaskets and o-rings (e.g. cover oil pump, adapter, male rotor inlet bearing).
16. Tighten the ferry head screws to the torques for Grade 8, Condition B fasteners in Table 11 in Section 7.3.

Section 7

SERVICING

TABLE 17
ROTOR END PLAY TOLERANCES

MEASURED END PLAY inch (mm)	CONDITION AND ACTION
0.0005 TO 0.0010 (0.0127 TO 0.0254)	Bearings are sound.
0.0010 TO .0020 (0.0254 TO 0.0508)	Bearings are questionable. Remove the coupling, piping, shaft seal and outlet cover as in Section 6.19. Inspect the outboard bearing raceway and rolling elements for visible damage (e.g. pit marks, scoring or loose cages). Reinspect every 1,000 hours if no sign of pitting or scoring.
0.0020 and above (0.0508 and above)	Remove the coupling, piping, shaft seal and outlet cover as in Section 6.19. Inspect the outboard bearing raceway and rolling elements for visible damage (e.g. pit marks, scoring or loose cages). Push the rotor by hand (50 lb. or 220 N on the lever) to the discharge end of the compressor. Measure the clearance between the end face of the rotor and the discharge housing by inserting feeler gauges through the discharge port with the capacity control slide valve in the maximum position. This clearance should be 0.002 inches to 0.005 inches (0.0508mm to 0.127mm) for all models. Contact Sullair Refrigeration with the measurements of both the end play and the rotor axial clearance and the compressor serial number, as the thrust bearings may have to be replaced.

17. Close the blowdown valve.
18. Open the suction stop valve and discharge stop valve.
19. Open the oil cooling (e.g. liquid injection, water lines or thermosiphon feed).
20. If equipped with Sullistage, open the Sullistage stop valves.
21. Reconnect the control panel to the 115V supply lines.
22. Reconnect the starter to the electric supply line.
23. Check for any leaks.
24. Start the compressor.

7.23 THRUST BEARING INSPECTION

From approximately December, 1986 to June, 1990, Sullair installed a bearing shield on the thrust bearings. Therefore, unless a bore scope is available, inspection of the thrust bearings will be impractical on these compressors. When the discharge pipe is removed, a visual inspection of the bearings through the discharge opening will verify if the bearings are equipped with the shields.

REMOVAL OF OUTLET END COVER

Refer to Figure 7-28.

1. Carry out the shutdown procedure in Section 7.2.
2. Place the capacity control slide valve in the maximum position by manually loading to max-

imum position. This prevents the capacity control slide valve from being knocked by the outlet end cover in Step 20.

3. Remove the coupling guard.
4. Remove the coupling as in Section 7.6.
5. **DO NOT** move either the compressor or the motor.
6. If the compressor is liquid injection-cooled, remove the refrigerant regulating valve bulb from the bulbwell in the discharge pipe. Remove the thermistor from the discharge pipe.
7. Disconnect the relief valve and pipework from the discharge pipe.
8. Remove the discharge pipe between the compressor and the oil separator.
9. Remove the discharge pressure control tubing from the outlet cover.
10. Remove the high discharge temperature thermostat bulb from the outlet cover using care not to kink the capillary tubing.
11. Loosen evenly the bolts (2 in Figure 7-5) between the shaft seal cover and the outlet housing.
12. Remove the shaft seal cover (1 in Figure 7-5). Break the flange loose with a rubber hammer.
13. Remove the seal housing (6 in Figure 7-5). Use screws in the three tapped holes to remove the housing if necessary.
14. Remove the rotating seal (4 in Figure 7-5) by pulling it off the shaft by hand.

TABLE 18
EYEBOLT DETAILS

MODEL	ROTOR EYEBOLT			HOUSING EYEBOLT		
	Thread Diameter	Pitch	Shank Length	Thread Diameter	Pitch	Shank Length
	inch	thread/in.	inch	inch	thread/in.	inch
C16	5/16	18	3.5	1/2	13	1.5
C20	3/8	16	4.0	1/2	13	1.5
C25	3/8	16	5.0	5/8	11	1.75

NOTE: All threads UNC

15. Remove the oil supply line to the square cap which supplies oil to actuate the capacity control slide valve.
16. Remove the four ferry head capscrews from the square cap. Twist (to break any binding of the oil supply tube so it can come out with the cap) and remove the square cap.
17. The oil supply tube may come out attached to the cap. If not, pull out the oil supply tube from the compressor by hand through the discharge port.
18. Remove the ferry head screws from the circumference of the outlet cover including the screw(s) in the discharge port.
19. Jack the outlet cover away from the discharge housing using three screws in the specially provided tapped holes in the flange on the outlet cover.
20. Maintain the outlet end cover as parallel to the outlet end as possible to prevent damage to the dowel pin holes in the cover.
21. Remove the outlet cover using care to avoid any contact between the outlet cover and the male rotor shaft. Lift the cover away from the compressor through the coupling space between the compressor shaft and the motor shaft.
22. Prevent dirt from entering the compressor by covering the discharge end with plastic or a clean cloth.

Figure 7-28 Removal of Outlet End Cover

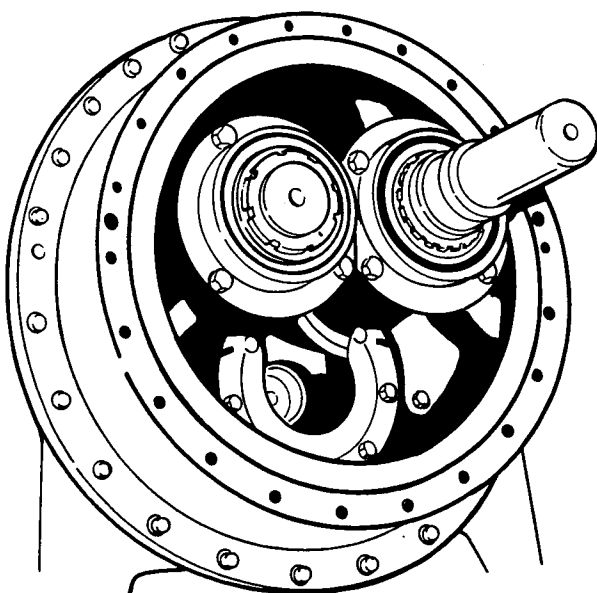

INSPECTION OF THRUST BEARINGS

Refer to Figure 7-29.

1. Inspect the raceway and rolling elements of the outboard bearings for pit marks or scoring and loose cages. Use a flashlight and mirror as necessary.
2. Examine the raceway and rolling elements of the inboard bearings using a flashlight and mirror. Although these inboard bearings are difficult to examine visually, **DO NOT** remove the locknuts and outboard bearings for better access.
3. Contact Sullair Refrigeration, if at all in doubt, about the condition of the thrust bearings.
4. Inspect the capacity control valve guides as in Section 7.24 (A. Inspection).

INSTALLATION OF THE OUTLET END COVER

1. Make sure the discharge end of the compressor is clean and no dirt has entered the compressor.
2. Clean the outlet cover flange and the outlet bearing housing or discharge housing.
3. Install a new o-ring into the groove in the flange of the discharge housing. Keep the o-

Section 7

SERVICING

- ring in place by applying a little grease in the o-ring groove.
4. Smear a film of Loctite 515 on the flange face of the outlet cover.
 5. Lift the outlet cover into place avoiding any contact with the male rotor shaft.
 6. Secure the outlet cover with two ferry head screws in the top half of the outlet cover.
 7. Install the dowel pins.
 8. Install the screws around the circumference of the outlet cover and tighten to the torque for Grade 8, Condition B bolts in Table 11 in Section 7.3.
 9. Make sure new bolt seals are used under the head of the screws which are mounted through the discharge port of the outlet cover.
 10. Install a new o-ring on the oil supply tube.
 11. Insert the oil supply tube into the compressor.
 12. Install a new o-ring in the square cap.
 13. Install the square cap with the four ferry head screws.
 14. Install the oil supply line to the square cap.
 15. Prepare the shaft seal parts and the shaft as in Section 7.6.
 16. Install the shaft seal as in Section 7.5.
 17. Install the discharge temperature thermostat bulb in the outlet cover.
 18. Install the discharge pressure control tubing in the outlet cover.
 19. Install the discharge pipe with new flange gaskets.

Figure 7-29 Inspection of Thrust Bearings

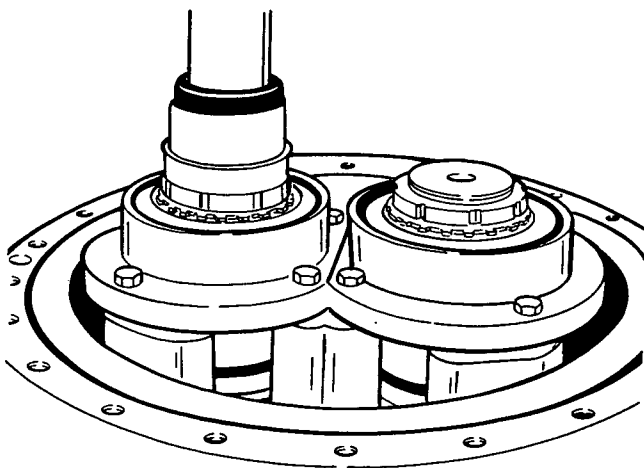

20. Connect the relief valve and pipework to the discharge pipe.
21. If the compressor is liquid injection-cooled, install the refrigerant regulating valve bulb into the bulbwell in the discharge pipe. Turn the bulb so that the word "top" stamped on the bulb faces upward before tightening. Also, install the thermistor into its coupling in the discharge pipe.
22. Install the coupling as in Section 7.6.
23. Install the coupling guard.
24. Close the blowdown valve.
25. Open the suction stop valve and discharge stop valve.
26. If the compressor is liquid injection-cooled, open the liquid refrigerant stop valve.
27. If the compressor is fitted with a Sullistage port, open the Sullistage stop valve.
28. Reconnect the control panel to the 115V supply line.
29. Reconnect the starter to the electric supply line.
30. Start the compressor.

7.24 CAPACITY CONTROL VALVE GUIDES INSPECTION

Refer to Figure 7-30. The capacity control valve is positioned and kept from rotating and therefore touching the rotors by a capacity control valve guide. There are two basic designs for valve guides in use. The first design valve guide is a machined surface of the discharge housing on each side of the discharge port. The later design is a separate valve guide mounted loose on the end of the stator and has two machined shoes supporting each upper side of the valve. The piston also assists in positioning the slide valve. The bore through which the piston is moving is machined to very close clearance and therefore prevents the valve from moving vertically upwards into the rotor.

A. INSPECTION

1. Carry out the shut down procedure in Section 7.2.
2. Place the capacity control valve in the maximum position per Section 7.15. This prevents the capacity control valve from being knocked when the outlet end cover is removed.
3. Remove the coupling, piping, discharge pipe, shaft seal and outlet end cover as in Section 7.23.
4. Return the capacity control valve to the minimum or fully unloaded position per Section 7.15. This moves the capacity control slide valve out from underneath the rotors for visual inspection.
5. Examine the capacity control slide valve for wear and contact marks from the rotor. If there has been any contact between the rotors and the valve it will appear as contact marks on either or both of the top surfaces of the valve. If there are any contact marks on the valve, the valve guides (4) will have to be readjusted, or if the compressor was built prior to serial num-

Section 7 SERVICING

Figure 7-30 Capacity Control Valve Guide

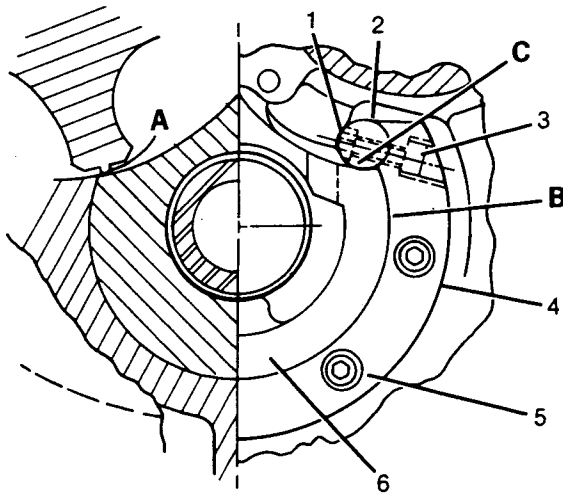
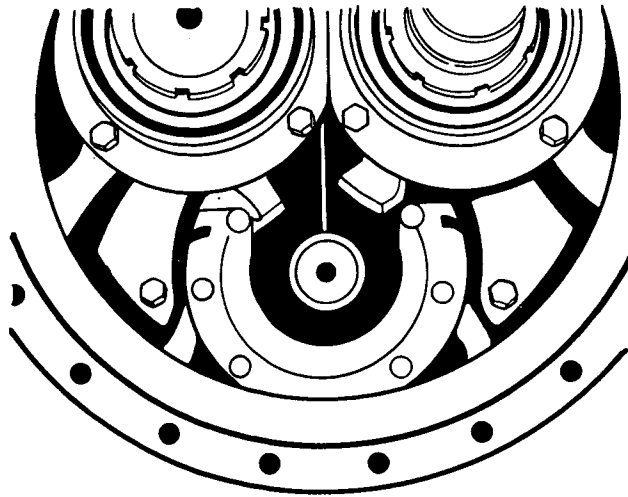

bers 6C16-21, 6C20-30 or 6C25-21, a separate valve guide should be installed and adjusted.

6. In compressors where a separate valve guide is already installed, check the clearance between the valve guide and the capacity control valve. Insert equal thicknesses of feeler gauges on each side of the valve between the valve guide surface and the valve as close to the outside edge of the valve as possible. This is shown as position C in Figure 7-30. If the clearance exceeds 0.0025" (0.0635mm) on each side, the valve guide has to be adjusted.

B. INSTALLATION AND ADJUSTMENT OF SEPARATE VALVE GUIDES

1. Remove the valve guide, if fitted, by unscrewing the four capscrews (5 in Figure 7-30).
2. Clean the face of the valve guide where it mounts on the stator.
3. Rotate the rotors such that both the male (not shown) and the female lobes (shown) are near the outer edges of the capacity control valve.
4. Insert equal shim thicknesses (e.g. feeler gauges) through the discharge port between the valve and the outside diameter of each of the rotors, to rotate the capacity control valve to the correct angular position relative to the rotors.
5. Place Loctite 515 on the valve guide surface that will be mounted on the stator.
6. Mount the separate valve guide (4).
7. Place Loctite 242 on the threads of the capscrews (5).
8. Install and snug up the capscrews (5) by hand.
9. Insert feeler gauges of 0.002" (0.0508mm) between the stator and each side (near the top) of the valve to center the valve in the stator. This is shown as Position B.
10. Insert feeler gauges of 0.001" (0.0254mm) between each guide shoe (2) and the surface of the valve. This is shown as Position C.
11. Press down evenly with one hand on top of each guide shoe (2) to make sure that the guide shoes are seated in full contact with the 0.001" (0.0254mm) feeler gauges and (in turn) the valve surface.
12. Tighten the capscrews (5) gradually and evenly. This will minimize any shifting of the valve guides as the screws are tightened.
13. With the valve guide in place, remove all the shims and all the feeler gauges from positions A, B and C.
14. Move the capacity control valve by hand to ensure it moves freely. Make sure that the circular portion of the valve does not hit the guide.
15. Install the outlet cover, shaft seal, piping and coupling and start the compressor as in Section 7.23.

7.25 ELECTRICAL CONTROLS SERVICING

Use the wiring diagram for the specific compressor to assist in locating a defective electrical component (the wiring diagram number is on the Sulair logo inside the electrical control panel). Re-

Section 7

SERVICING

place defective controls with the new standard industrial controls.

DO NOT attempt to repair electrical components.

7.26 COMPRESSOR UNIT REPLACEMENT

Should replacement of the Sullair compressor unit be necessary, the following procedures will ensure correct replacement and minimize down time. It is recommended that Sullair Refrigeration Service Department be involved in the decision to change compressor units.

They will also assist in the ordering of the new unit and scheduling of a Sullair Service technician if required.

REMOVAL

1. Carry out the shut down procedure in Section 7.2.
2. Remove tubing in large subassemblies. This will save time and confusion when installing the new unit. Avoid bending the tubing assemblies. In most cases, the assemblies will fit the new unit.
3. When removing the old unit, install temporary pipe hangers to facilitate installation of the new unit.
4. Return the old unit to Sullair Corporation in the same crate in which the replacement was shipped.

INSTALLATION

1. Change the oil filter element and thoroughly clean every oil strainer.
2. Thoroughly clean all tubing and piping with solvent and brush before refitting to compressor.

3. Reconnect the tubing and piping as in a standard unit or per Replacement instruction.
4. Follow the pressure test procedure as in Section 4.8.
5. Follow the evacuation procedure as in Section 4.9.
6. Follow the alignment procedure in Section 4.10.
7. Drain and discard all the oil from the package by opening the drain valve on the bottom of the oil separator, and then removing the drain plug from the bottom of the oil cooler (if water-cooled or thermosiphon) or loosening the oil tubing, whichever allows draining of low spots in oil piping.
8. Flush the package with clean oil through the discharge temperature connection on the oil separator.
9. Replace the drain plugs, close the oil separator drain valve and charge the system with new oil as in Section 4.12.
10. Warm the oil as in Section 4.13.
11. Check the electrical system as in Section 4.14.
12. Check the protective switches as in Section 4.15.
13. Check the capacity control as in Section 4.16 or 4.17.
14. Follow the pre-start check list as in Section 5.3.
15. Follow the initial start-up procedure as in Section 5.4.
16. Follow the initial maintenance procedures as for a new compressor as in Sections 6.2 and 6.3.

NOTES

NOTES



WORLDWIDE SALES AND SERVICE

SULLAIR CORPORATION

A SUBSIDIARY OF SUNDSTRAND CORPORATION

3700 E. Michigan Blvd. Michigan City, Indiana 46360-9990
Telephone (219) 879-5451 Telex 4946922



Part No.



252666

Printed in U.S.A. SP

Specifications Subject To
Change Without Prior Notice