

Original User Manual

GD PILOT
electronics for stationary
rotary screw compressor

German basis BA ZS1054346 / 04

Valid as of software version DPro-L-1.xx

We reserve the right to modifications relating to technical advances.

Contents

1	Operator controls / arrangement	3
1.1	Keys	3
1.2	Status indicator (display / light signals)	3
1.2.1	Status messages in display	4
1.3	Menu structure (values are examples)	5
1.4	Displaying / changing values	6
1.4.1	Selecting values	6
1.4.2	Changing values	6
2	Default settings	7
2.1	Selecting language	7
2.2	Setting network pressure	7
2.3	Setting time/date (timer)	7
3	Operations	8
3.1	Starting the unit	8
3.2	Emergency off button	8
3.3	Switching off the unit	8
3.4	On-load/off-load	8
3.5	Acknowledging warning/fault messages	8
3.5.1	Warning messages	8
3.5.2	Fault messages	8
4	Maintenance ([MAINTENANCE SCHED.] sub-menu)	9
4.1	Maintenance	9
4.2	Programming maintenance intervals	9
4.3	Total/load hours counter	9
5	Extended functions	10
5.1	[CONTROL MENU] sub-menu	10
5.1.1	Operating modes	10
5.1.2	Second pressure range (F ₂)	10
5.1.3	Dryer pre-run	10
5.1.4	RS 485 communication	10
5.1.5	Automatic re-start	11
5.1.6	Unlimited autom. re-start after power loss	11
5.2	[FAULT MEMORY] sub-menu	12
5.3	[TIMER CONTROL] sub-menu	12
5.3.1	Setting for timer units	12
5.3.2	Pressure changeover setting	13
5.4	[Limit values] sub-menu	14
5.5	[OPTIONAL IN-/OUTPUTS] sub-menu	15
5.5.1	Inputs	15
5.5.2	Outputs	16
5.6	Locking / unlocking code	16
5.7	Replacing the GD PILOT (SETUP-CODE)	17
5.8	Remote control	18
5.8.1	Remote control for pressure changeover	18
5.8.2	On-load/off-load remote control	19
5.8.3	Remote start / stop	20
6	Error rectification	21
6.1	Warnings	21
6.2	Faults	21
6.3	Checklist	21
6.4	Table of faults / warnings	21

1. Operator controls / arrangement

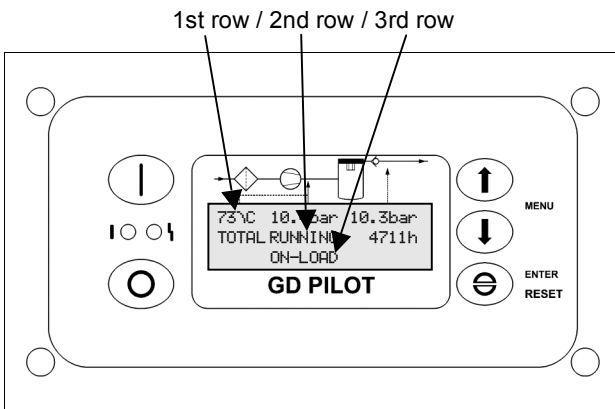

1.1 Keys

- ⏻ Switch on unit
- ⏻ Switch off unit

The three keys on the right next to the display have a dual function:

- ⏻ + ⏻
at the same time Call up or exit menu, exit menu / sub-menu
- ⏻ Switch to next sub-menu / menu item, or reduce a value
- ⏻ Switch to previous sub-menu / menu item, or increase a value
- ⏻ Acknowledgement key,
if you are in a menu / sub-menu, the acknowledgement key functions as an Enter key [↵].

1.2 Status indicator (display / light signals)

The control system is fitted with a three-row display.

1st row:

The final compression temperature, final - compression pressure and network pressure are permanently displayed here.

Final compression temperature: is the temperature measured downstream of the compressor stage.

Final compression pressure: is the pressure measured downstream of the compressor stage.

Network pressure: is the pressure within the system connected downstream of the compressor.

The following symbols may also be used in the 1st row:

- F₂ Second pressure range / timer active
- ⚡ Remote start / stop activated

2nd row:

The second row is reserved for the menu. You can view values like the total service hours and set values like the nominal pressure in the menu.

3rd row:

The third row shows status, fault and warning - messages.

Light signals

The GD PILOT is fitted with two light signals (red, green).

Red light signal:

- Flashing slowly: warning, maintenance due
- Flashing rapidly: fault, unit is stopped until fault has been rectified

The red light signal only goes out once the warning or fault has been remedied properly.

Green light signal:

- Flashing: system is ready, i.e. the motor may start up automatically at any time.

Lit up permanently: the drive motor is running

1. Operator controls / arrangement

1.2.1 Status messages in display

The status messages are shown in the 3rd row of the display. With longer texts, the indication may 'alternate'.

Status messages:

READY TO START

The unit is ready to start and can be switched on (see section 3.1).

WARNING START WITH ...

alternating with

... DE-PRESSURISE

The unit has been switched on and is ready. The unit starts automatically following the pressure requirement from your system.

WARNING START WITH ...

alternating with

... DE-PRESSURISE

The unit has been switched on and is ready. However the internal unit pressure is above the start-up protection level. Once the unit has been de-pressurised, the compressor starts automatically.

WARNING START WITH ...

alternating with

... TIMER CONTROL

The unit has been switched on and is ready. The compressor is now waiting for start approval from the timer (see section 5.3)

WARNING START BY ...

alternating with

... REMOTE OPERATION

The unit has been switched on and is ready. Remote unit operations have been activated in the control menu. The unit starts via a remote signal (see section 5.8).

WARNING START IN xx s

alternating with

... AFTER POWER LOSS

A power loss has caused the unit to shut down. The 'automatic restart' function has been selected in the control menu. The unit now starts automatically after a previously set time (see section 5.1.5)

WARNING START IN

alternating with

... AFTER DRYER PRE-RUN

The unit has been switched on and is ready. The unit starts automatically after the dryer pre-run (see section 5.1.3).

MOTOR START PHASE

The unit has been switched on and the motor is starting

SOFT STOP TIME in xx s

The system has been switched off. The unit stops after the soft-stop time of xx seconds.

FAULT: <fault text>

The unit has been shut down due to a fault. You will find explanations of the fault texts in section 6.

WARNING <warning text>

There is a warning in place. Ignoring a warning may result in a fault and shut down the compressor. You will find explanations of the warning texts in section 6.

MAINTENANCE ELAPSED

A maintenance interval is about to lapse or has already done so, you will find more details in section 4.

ON-LOAD

The compressor is on-load (see section 3.4).

OFF-LOAD

The compressor is off-load (see section 3.4).

RUN-ON TIME xx s

The unit has been switched off and is now in off-load for xx seconds. After xx seconds the unit automatically shuts down and is ready to start again.

1. Operator controls / arrangement

1.3 Menu structure (values are examples)

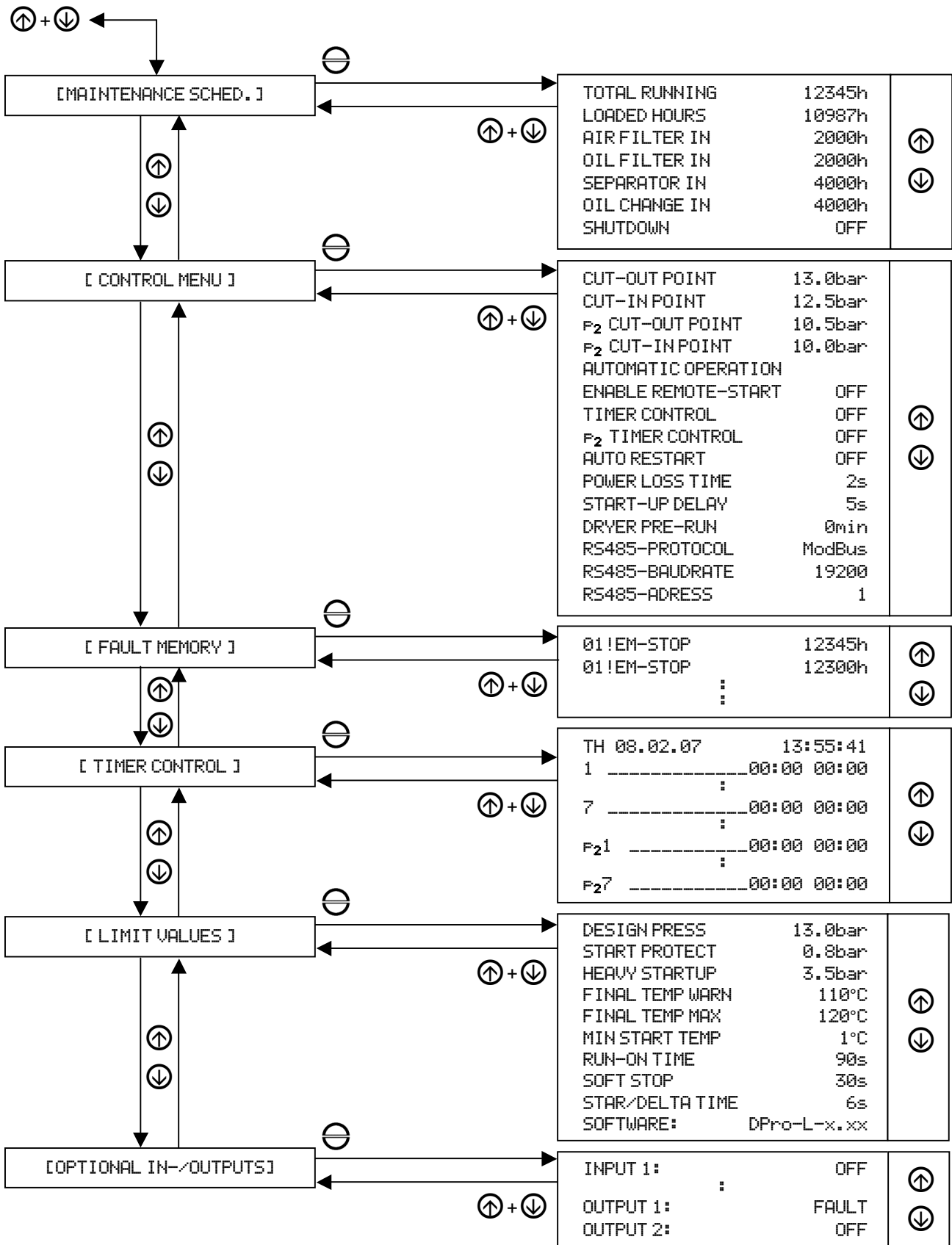

1.4 Displaying / changing values

1.4.1 Selecting values

You can display values, e.g. total hours, and set the control system, e.g. cut-in and cut-out times, in the sub-menu.

To reach the main menu, you must press the ⏪ + ⏩ keys at the same time.

You can use the ⏪ or ⏩ keys to switch between the following sub-menus:

```
[MAINTENANCE SCHED.]  
[ CONTROL MENU ]  
[ FAULT MEMORY ]  
[ TIMER CONTROL ]  
[ LIMIT VALUES ]  
[OPTIONAL IN-/OUTPUTS]
```

Enter a sub-menu by pressing the ⏴ key.

Again here you can use the ⏪ or ⏩ keys to go to a menu item.

To exit the sub-menu, you must press the ⏪ + ⏩ keys at the same time.

To then fully exit the main menu, you must again press the ⏪ + ⏩ keys at the same time.

1.4.2 Changing values

Enter the sub-menu and then the menu item containing the value you wish to change.

Then press the ⏴ key, the value flashes. You can now press ⏪ or ⏩ to change the value. You must then press the ⏴ key again to confirm the value.

2. Default settings

2.1 Selecting language

You can change the language by pressing the \ominus + \oplus or \ominus + \odot keys. Press these keys at the same time until the right language appears.

2.2 Setting network pressure

The compressor is controlled using an electronic pressure switch. In the [CONTROL MENU] menu you have to set the minimum network pressure switching point (CUT-IN POINT) and the maximum network pressure switching point (CUT-OUT POINT).

When the maximum network pressure switching point is reached, the machine switches to off-load.

The minimum network pressure switching point then specifies when the machine is switched back into on-load.

Example:

CUT-OUT POINT	10.0bar
CUT-IN POINT	9.8bar

When the network pressure reaches 10.0 bar, the machine switches to off-load.

If the network pressure then falls to 9.8 bar, the machine is switched back into on-load.

Max. network pressure:

The network pressure is set in the [CONTROL MENU] sub-menu. The \oplus + \odot keys have to be pressed at the same time to do this. You are then taken to the main menu. Use \odot to switch to the [CONTROL MENU] sub-menu. Then please press the \ominus key.

The CUT-OUT POINT menu item now appears on the display. Again pressing the \ominus key causes the value to flash. You can now correct (increase or decrease) this value using \oplus or \odot . Then confirm the value set by pressing the \ominus key.

Note

The control system checks whether the value set can be used. The maximum network pressure CUT-OUT POINT must be at least 0.2 more than the minimum network pressure CUT-IN POINT. You may therefore have to first set the minimum network pressure point. To prevent your compressor suffering from excess wear, the difference between the CUT-OUT POINT and CUT-IN POINT should not be too small.

Min. network pressure:

In the [CONTROL MENU] sub-menu please use \odot to go to the CUT-IN POINT menu item.

Pressing the \ominus key causes the value to flash.

You can now correct (increase or decrease) this value using \oplus or \odot . Then confirm the value set by pressing the \ominus key.

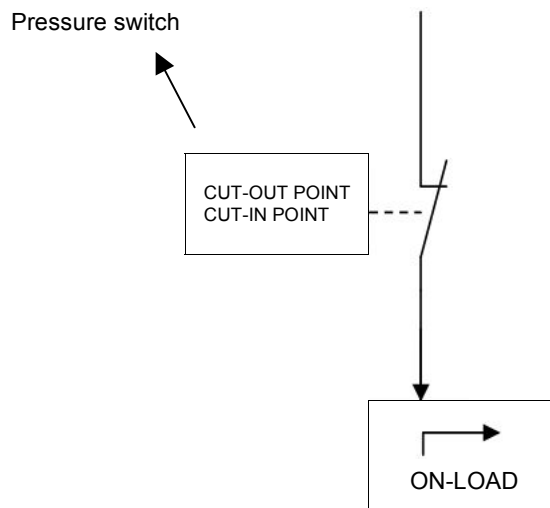

Fig. 1 Block diagram

2.3 Setting time/date (timer)

The GD PILOT accumulator can bridge a loss of power lasting between around two to three weeks. If power is lost for longer periods, the timer's time and date are lost and have to be entered anew.

Press the \oplus + \odot keys at the same time. Use \odot to go to the [TIMER CONTROL] sub-menu and press the \ominus key. The date and time are displayed there in the following format:

TU 30.10.07 12:10:34

If you press the \ominus key, the left-hand value (day of the week) starts to flash. You can now use the \oplus or \odot keys to set this. Then confirm the value by pressing the \ominus key.

All values can now be set in succession using this procedure. When the last value (seconds) has been set, the timer is fully set and you can exit the menu by twice pressing the \oplus + \odot keys at the same time.

3. Operations

3.1 Starting the unit

Danger

If the unit is ready, i.e. the green LED is flashing, the compressor may automatically start at any time.

Use the main switch to switch the unit on.

If warning or fault messages appear in the third row of the display, these first have to be rectified and confirmed using the  key.

Then start the unit by pressing the  key on the GD PILOT.

3.2 Emergency off button

The emergency off button is located above the GD PILOT. It is used to immediately shut down the unit. Only use the emergency off button to shut down the unit in emergencies. When shutting down normally, always use the  key.

3.3 Switching off the unit

The unit is switched off by pressing the  key on the GD PILOT. However the unit will only stop after a 30-second soft-stop.

The soft-stop is preset to protect the compressor.

Note

The unit may only be shut down using the emergency off button in real emergencies. When shutting down normally, please use the  key.

3.4 On-load/off-load

Descriptions of the CONTINUOUS OPERATION and AUTOMATIC OPERATION modes can be found in section 5.1.1.

OFF-LOAD:

If there is no network pressure requirement from the compressed air system and the unit is in CONTINUOUS OPERATION, it switches to OFF-LOAD. This means that the motor and compressor stage run but no air is pumped into the compressed air system.

The unit behaves differently if in AUTOMATIC OPERATION mode. If there is no network pressure requirement, the compressor switches to OFF-LOAD. The unit is switched off after a run-on time that is shown on the display. If there is another pressure requirement during the run-on time, the unit is automatically switched on.

ON-LOAD:

If the unit is in ON-LOAD, air is pumped into the compressed air system.

3.5 Acknowledging warning/fault messages

Warning and fault messages are shown in the third row of the display. The red light signal flashes at the same time.

You will find a table containing the messages and - suggestions for how to remedy them in section 6.4.

3.5.1 Warning messages

When there are warnings, the red light signal flashes slowly. The unit does not automatically shut down when there are warnings. However ignored warnings may cause faults.

Rectify what is causing the warning and press the  key to hide the warning.

3.5.2 Fault messages

Fault messages result in the unit automatically shutting down or do not permit the unit to be started.

Once you have rectified the problem, you still have to confirm by pressing the  key.

4. Maintenance ([MAINTENANCE SCHED.] sub-menu)

4.1 Maintenance

The maintenance intervals are preset when the compressor is supplied. You will find more information in the unit's overall operating instructions.

It may however be necessary for the maintenance - intervals to be adjusted individually to your ambient conditions. For example, the air filter's level of contamination depends on the compressor's intake conditions.

The GD PILOT allows the operator to program various maintenance intervals (see section 4.2).

If there is a maintenance interval at 200h (hours), the compressor is not automatically shut down. The MAINTENANCE ELAPSED message appears on the display.

If you want the compressor to automatically shut down when a maintenance interval is due, you have to set this function. To do this, please go to the [Times] sub-menu. Go to the last SHUTDOWN OFF menu item. Now press the \ominus key. The OFF value now starts to flash. By pressing the \oplus key you can change the value to ON. Finally you need to confirm using \ominus .

The compressor now automatically shuts down when the 100h maintenance interval is displayed.

Once maintenance has been carried out, the maintenance interval should be reprogrammed. The maintenance message can be acknowledged using the \ominus key.

4.2 Programming maintenance intervals

To program a maintenance interval, please go to the [MAINTENANCE SCHED.] sub-menu. Here you can program the maintenance intervals for:

AIR FILTER IN	2000h
OIL FILTER IN	2000h
SEPARATOR IN	4000h
OIL CHANGE IN	4000h

Go to the menu item required. Please press the \ominus key. The value then starts to flash. You can use \oplus or \ominus to now set the value to an interval of 0...9999. Confirm your entry with the \ominus key.

If you do not want the maintenance intervals to be monitored, program the intervals to more than 9999 hours in the various menu items. ---- appears on the display. The maintenance interval is then blocked.

Note

The values shown are examples only. The values used in your unit may be different.

4.3 Total/load hours counter

You will find the total/load hours counters in the [MAINTENANCE SCHED.] sub-menu. To do this, please press the \oplus + \ominus keys at the same time. You are then taken to the main menu. Then please press the \ominus key. You are now in the [MAINTENANCE SCHED.] sub-menu. You can use the \oplus or \ominus keys to now go to the various menu items.

The total hours counter states the time for which your unit has been in on-load and off-load.

The load hours counter states the time for which your unit has been in on-load.

Note

The total and load hours are lost when the GD PILOT is replaced.

5. Extended functions

5.1 [CONTROL MENU] sub-menu

The most important parameters of the [CONTROL MENU] menu have already been explained in section 2 Default settings. This section simply contains an overview and explanation of additional (extended) functions.

5.1.1 Operating modes

Go to the [CONTROL MENU] sub-menu and use the \odot key to go to the AUTOMATIC OPERATION menu item. If you press the \ominus key, the AUTOMATIC OPERATION value starts to flash. You can use the \oplus key to now switch to CONTINUOUS OPERATION. Confirm a set value by pressing the \ominus key.

You can choose from two operating modes:

AUTOMATIC OPERATION

AUTOMATIC OPERATION is the most economical of your compressor's operating modes. If there is no need for compressed air in your system, the compressor is shut down after the RUN-ON TIME. The control system automatically recognises when compressed air is needed again. The unit then starts up straight away.

CONTINUOUS OPERATION

CONTINUOUS OPERATION is only needed for some special applications. When in this operating mode, the motor is not shut down if there is no longer any need for pressure. The compressor stage now runs continually in off-mode when there is no need for pressure.

5.1.2 Second pressure range (F₂)

The range between the maximum and minimum network pressure is called the pressure range. The second pressure range function allows you to use another pressure range in addition to the pressure range already set (see section 2.2). This could be used to for example implement night-time lowering.

You will find the settings for the second pressure range function in the [CONTROL MENU] sub-menu. The relevant menu items there are:

F ₂ CUT-OUT POINT	10.5bar
F ₂ CUT-IN POINT	10.0bar
F ₂ TIMER CONTROL	OFF

You can use F₂CUT-OUT POINT and F₂CUT-IN POINT to set the network pressure switching points. Use the F₂TIMER CONTROL On menu item to activate the timer for the second pressure range.

You can activate / deactivate the second pressure range using an external potential-free contact (see section 5.5).

Section 5.3.2 contains a description of how to set the timer for the second pressure range.

Note

The values shown are examples only. The values used in your unit may be different.

5.1.3 Dryer pre-run

If you are using an external dryer, you can provide the compressor with a specified pre-run time. The compressor is then only started after this pre-run time.

To set the pre-run time, please go to the [CONTROL MENU] sub-menu. From there use the \odot key to go to the DRYER PRE-RUN \ominus min menu item. Once you have pressed the \ominus key, the \ominus min value starts to flash. You can now use the \oplus or \ominus keys to set the pre-run time you want. Then confirm your entry using the \ominus key.

5.1.4 RS 485 communication

You can perform the settings for RS 485 communication in the [CONTROL MENU] sub-menu. The

RS485-PROTOCOL	ModBus
RS485-BAUDRATE	19200
RS485-ADDRESS	1

menu items are of relevance.

The GD PILOT has a serial RS485 interface. This interface can be used with the ModBus RTU protocol.

ModBus interfaces and drivers are available from many of the well-known manufacturers of programmable logic controllers (PLC).

You can set the baud rate you want in the RS485-BAUDRATE menu item.

You can set the participant number you want in the RS485-ADDRESS menu item.

Note

The values shown are examples only. The values used in your unit may be different.

5. Extended functions

5.1.5 Automatic re-start

Danger

In this operating mode, the compressor may start automatically at any time and after an unlimited - length of power loss.

Always fit the compressor with warning signs, lock the room containing the compressor and instruct your staff.

Fit the main switch specified by EN60204 and fit the appropriate warning signs on it.

After a power loss that has not exceeded the preset time, the unit can re-start automatically.

The settings needed must be undertaken in the [CONTROL MENU] sub-menu. The relevant menu items are:

AUTO RESTART	OFF
POWER LOSS TIME	Xs
START-UP DELAY	Xs

Use the AUTO RESTART ON menu item to activate the automatic re-start.

You can state the time for which a power loss may last and after which the compressor is to automatically start up in the POWER LOSS TIME menu item. The time can be set within a period of 2 - 999 seconds. If the power loss lasts longer than the time you have set, the unit does not automatically re-start. The POWER LOSS. fault message then appears on the display

You can also program a start-up delay of 1 – 60 seconds. This is set in the START-UP DELAY menu item and ensures a staggered start-up if the unit features several compressors. This in turn ensures that the power supply is not loaded unnecessarily.

5.1.6 Unlimited autom. re-start after power loss

The control system can perform an automatic re-start after any power loss period.

For this to be done, you must have read the following safety notices and submit the approval for the unlimited automatic re-start by entering a code.

Please request the required code from the Gardner Denver customer service.

Danger

In this operating mode, the compressor may start automatically at any time and after an unlimited - length of power loss. Check the safety notices (e.g. EN1012-1, EN60204) that apply in your country to find out whether you can run an unlimited autom. re-start and what safety precautions must be taken.

Always fit the compressor with warning signs, lock the room containing the compressor and instruct your staff.

Fit the main switch specified by EN60204 and fit the appropriate warning signs on it.

To approve the unlimited automatic restart, proceed as follows:

1. Press the \ominus key for 5 seconds.
2. Use the \odot or \ominus keys to enter the code
3. Press the \ominus key to transfer the set code

After approval, the menu item for the max. power loss time can also be programmed to [POWER LOSS TIME \rightarrow s]. This is the setting for an unlimited automatic re-start.

If you re-enter the code, you cancel the approval.

Note

You will find more details about the code in section 5.6

5. Extended functions

If there are no days of the week selected in the switching unit line, the switching unit is not active. The switching unit only becomes active when the day of the week is set. When the \ominus is pressed, the first underscore $_$ starts to flash. You can now use the \oplus key to set the first day of the week (Sunday). Then use the \ominus key to confirm the day of the week. The next underscore $_$ then starts to flash. If you do not want to confirm a day of the week as set, please immediately press \ominus . You can run through all seven days of the week in this way. Once you have confirmed the last day of the week (Saturday), the first unit of the switch-in - point starts to flash. You can either set this using \oplus or \ominus . Once the last unit of the switch-out point has been confirmed, the whole timer unit is activated.

The next step is to go to the [CONTROL MENU] sub-menu and then the TIMER CONTROL menu item. You will now see the default setting TIMER CONTROL OFF. If you press the \ominus key, the OFF value starts to flash. You can now use the \oplus key to change the value to ON. Then please press the \ominus key again to confirm the entry. The timer is now switched on.

To improve your understanding of this function, the timer unit setting is explained below using various examples.

Example 1:

Switching unit 1 not active:

```
1 _ _ _ _ _ 00:00 00:00
```

Example 2:

The unit should run Monday to Friday between 7.30 am and 4.15 pm.

```
2 _MTWTF_ 07:30 16:15
   ↓       ↓       ↓
   a)      b)      c)
```

- a) Days of the week Monday to Friday
- b) Switch-in point
- c) Switch-off point

Example 3:

The unit is to run from Sunday 10 pm through continuously to Saturday 2 pm. However during the daily break (12 midday to 12.30 pm), the unit is to be shut down.

You will now have to use various switching units. The following settings would be needed in this case:

```
1 S_ _ _ _ _ 22:00 00:00 → a)
2 _MTWTF5 00:00 12:00 → b)
3 _MTWTF_ 12:30 00:00 → c)
4 _ _ _ _ _S 12:30 14:00 → d)
5 _ _ _ _ _ 00:00 00:00
6 _ _ _ _ _ 00:00 00:00
7 _ _ _ _ _ 00:00 00:00
```

- a) Start of operating period
- b) Operating period up until lunch break
- c) Start of operation after lunch break
- d) End of operating period

5.3.2 Pressure changeover setting

Please go to the [TIMER CONTROL] sub-menu. There you can use \oplus or \ominus to select between various timer units. The timer units of the 2nd (F₂) pressure range are in the menu under the normal timer units.

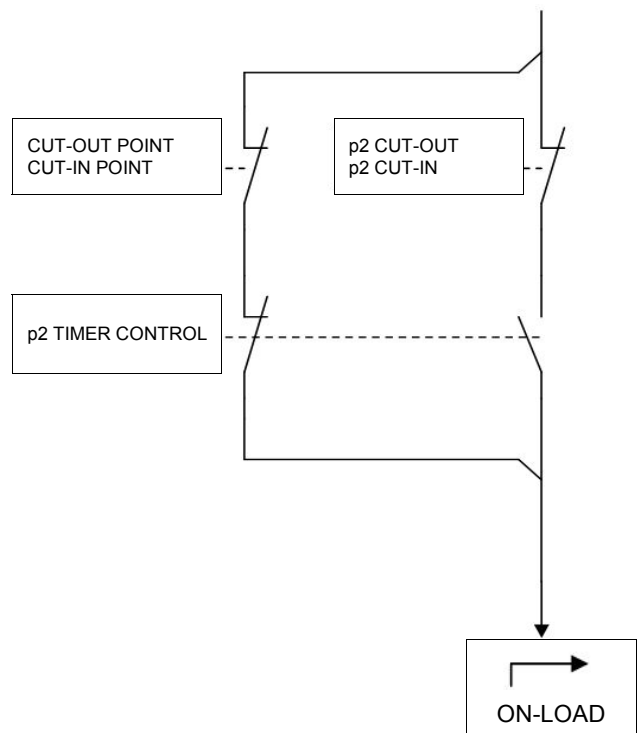

Fig. 2 Pressure changeover block diagram

5. Extended functions

Seven timer units are again available here for the setting (programming). The values that you have set for the second pressure range supersede the values for CUT-OUT POINT and CUT-IN POINT as soon as a switching unit is active. The 1st row on the display then shows the F_2 symbol in front of the final compression temperature. If the switching unit becomes inactive, the values for CUT-OUT POINT and CUT-IN POINT are again used.

The status line of each switching unit is as follows:

a) b) c) d) e)
 F_2 1 _ _ _ _ 00:00 00:00

- a) 2nd pressure range
- b) Unit no.
- c) Days of the week [SMTWTFSS] = Sunday, Monday...
- d) Switch-in point
- e) Switch-out point

When the \ominus is pressed, the first underscore _ starts to flash. You can now use the \oplus key to set the first day of the week (Sunday). Then use the \ominus key to confirm the day of the week. The next underscore _ now flashes. If you do not want to confirm a day of the week as set, immediately press \ominus . You can run through all seven days of the week in this way. Once you have confirmed the last day of the week (Saturday), the first unit of the switch-in point starts to flash. You can either set this using \oplus or \ominus . Once the last unit of the switch-out point has been confirmed, the whole switching unit is activated.

Go to the [CONTROL MENU] sub-menu and then the F_2 TIMER CONTROL menu item. You will now see the F_2 TIMER CONTROL OFF default setting. If you press the \ominus key, the OFF value starts to flash. You can now use the \oplus key to change the value to ON. Then please press the \ominus key again to confirm the entry. The timer is now switched on for the second pressure range. Please refer to section 5.1.2 for how to set the parameters for the 2nd pressure range.

5.4 [LIMIT VALUES] sub-menu

The [LIMIT VALUES] sub-menu is for information only. Here you can access the parameters set in the factory. The following are shown:

a)	DESIGN PRESS	13.0bar
b)	START PROTECT	0.8bar
c)	HEAVY STARTUP	3.5bar
d)	FINAL TEMP WARN	110°C
e)	FINAL TEMP MAX	120°C
f)	MIN START TEMP	1°C
g)	RUN-ON TIME	90s
h)	SOFT STOP	30s
i)	STAR/DELTA TIME	6s
j)	SOFTWARE:	DPro-L-x.xx

Note

The values shown are examples only. The limit values in your unit may be different.

- a) This is your unit's operating pressure. This is also stamped on the compressor's name plate.
- b) To protect the compressor stage, the compressor only starts up when the compressor's internal pressure is less than or equal to the set value. If the compressor's internal pressure is higher when starting up, the following appears in the display's third row:

WARNING START AFTER ...

 alternating with

... DE-PRESSURISE
- c) If the internal pressure builds up too quickly when the compressor starts up, there is an error in the unit. To protect the motor in the case of an error, the machine shuts down if pressure builds up too quickly. FAULT HEAVY STARTUP appears in the third row on the display.
- d) If the final compression temperature reaches 110 °C, WARNING HIGH TEMP appears in the display's third row.
- e) If the final compression temperature reaches 120 °C, the compressor shuts down. FAULT COMP TEMP then appears in the third row on the display
- f) If the temperature in the compressor station is below 1 °C, the machine cannot start up.
- g) If the compressor is in automatic mode and there is no network pressure requirement, the RUN-ON TIME xxxs indication appears and the machine goes into off-load. After the run-on time (xxx), the compressor automatically shuts down and is ready to start again. If using the timer or the remote start / stop function, the run-on time is also used.

5. Extended functions

- h) In order to protect the compressor stage, once the \ominus key (shut down system) has been pressed, the compressor is only switched off 30 seconds later.
- i) During the start-up phase, a change is made from star to delta (contactors in switch panel) following the set value.
- j) You can find the software currently loaded on your unit here.

5.5 [OPTIONAL IN-/OUTPUTS] sub-menu

5.5.1 Inputs

Attention

Only potential-free contacts may be connected to the terminal strip. External voltages will destroy the GD PILOT.

The potential-free contacts must not be more than 20 metres away from the terminal strip. If necessary coupling relays must be fitted in the control cabinet.

The GD PILOT has five programmable inputs. These inputs can be assigned (programmed) various functions. The various functions are listed below. Each input can be programmed with each function.

The inputs are programmed in the [OPTIONAL IN-/OUTPUTS] sub-menu. Please go to the [OPTIONAL IN-/OUTPUTS] sub-menu. Then go to the \ominus INPUT 1: FREE menu item.

If you press the \ominus key, the function starts to flash. By pressing the \oplus or \ominus key, you can now change the function. Once you have set the function you want, this has to be confirmed using the \ominus key. The input is now programmed.

You access all other programmable inputs by pressing the \oplus or \ominus key.

Explanation of functions:

FREE

Input is not assigned (programmed).

EXT FAULT

If the contact is opened, the EXT FAULT fault message appears on the display and the unit is shut down (shutting down is delayed by 1sec.).

EXT WARNING

If the contact is opened, the EXT WARNING warning message appears on the display (the indication is delayed by 1sec.). This function does not result in the unit shutting down.

DRYER FAULT

If the contact is opened, the DRYER FAULT fault message appears on the display and the unit is shut down (shutting down is delayed by 1sec.).

DRYER WARNING

If the contact is opened, the DRYER WARNING warning message appears on the display (the indication is delayed by 1 sec.). This function does not result in the unit shutting down.

(BEKOMAT FAULT

If the network pressure is ≥ 1.0 bar and the contact is opened for at least 250sec., (BEKOMAT FAULT appears on the display. This function results in the unit shutting down.

BEKOMAT WARN.

If the network pressure is ≥ 1.0 bar and the contact is opened for at least 250sec., BEKOMAT WARN. appears on the display. This function does not result in the unit shutting down.

ENAB. REM. LOAD

For use and examples, see section 5.8.2.

REMOTE LOAD

For use and examples, see section 5.8.2.

2nd PR. RANGE (2nd pressure range)

If the contact is closed, the system changes over to the second pressure range. Also refer to section 5.1.2.

RTC OVERRIDE

The timer can be overridden using this input.

Example: The compressor has been shut down by the timer. If the contact is now closed, the compressor starts up.

ENABLE REMOTE-START

For use and examples, see section 5.8.3.

5. Extended functions

5.5.2 Outputs

Attention

The maximum connected loads for the programmable outputs (relay contacts) are 1A / 240V.

The GD PILOT has two programmable outputs. Output 1 is a relay with changeover contact and output 2 is a relay with NO contact. You can assign (program) various functions to the outputs.

The outputs are programmed in the [OPTIONAL IN-/OUTPUTS] sub-menu. Please go to the [OPTIONAL IN-/OUTPUTS] sub-menu. Then go to the \odot OUTPUT 1: FAULT menu item

If you press the \ominus key, the function starts to flash. By pressing the \odot or \oplus key, you can now change the function. Once you have set the function you want, this has to be confirmed using the \ominus key. The output is now programmed.

You access the other programmable output by pressing the \odot key.

When supplied, output 1 is programmed with the 'FAULT' function. Output 2 is not programmed upon delivery. Each of the two outputs can be programmed with any of the functions listed below. You will also find an overview of the inputs and associated functions in the machine's circuit diagram.

Explanation of functions:

FREE

Output is not programmed.

OPERATING

The output (relay) is activated when the compressor's motor is switched on or when the compressor is ready.

ON-LOAD

The output (relay) is activated when the compressor is in on-load.

OFF-LOAD

The output (relay) is activated when the compressor is in off-load.

FAULT

The output (relay) is activated when there are no faults on the compressor.

WARNING

The output (relay) is activated when there are no warnings on the compressor.

MAINT. ELAPSED

The output (relay) is activated when there are no maintenance messages on the compressor.

WARNING/MAINT.

The output (relay) is activated when there are no warnings and no maintenance messages on the compressor.

WARN/MA/FAULT

The output (relay) is activated when there are no warnings, no maintenance messages and no faults on the compressor.

REM. STARTABLE

The output (relay) is activated when the compressor is ready for the remote start.

RUNNING

The output (relay) is activated when the compressor's motor is running (is switched on).

2nd PR. RANGE

The output (relay) is activated when the 2nd pressure range is applicable.

TIMER

The output (relay) is activated when the compressor is switched on by the internal timer.

5.6 Locking / unlocking code

Settings (sub-menus) can be locked using a code to prevent unauthorised programming.

Limit values cannot be changed by the operator.

Locking

If the code is to be locked, this is done using the \ominus key. Please press this key for 5 seconds. The following message then appears on the display:

CODE: UNLOCK (for 1 second)

CODE INPUT 0000 (0000 value flashes)

If the code: 3022 is entered, the following message appears:

CODE: LOCK (for 1 second)

The sub-menus are now locked and cannot be changed.

If the wrong code is entered, the following message appears:

CODE: UNLOCK (for 1 second)

The display then automatically jumps back to where it started from.

Unlocking

If the code is to be unlocked again, this is either done by:

- * pressing (for 5 seconds) the \ominus key when not in the menu or
- * pressing (for 5 seconds) the \ominus key when attempting to change a protected value in a sub-menu.

5. Extended functions

The code prompt then appears:

CODE: LOCK (for 1 second)

CODE INPUT 0000 (0000 value flashes)

Here you must enter the code: 3022.

If the code is entered correctly, the following message appears:

CODE: UNLOCK (for 1 second)

If the code is entered incorrectly, the following message appears:

CODE: LOCK (for 1 second)

The display then automatically jumps back to where it started from.

5.7 Replacing the GD PILOT (SETUP-CODE)

Once the new GD PILOT has been fitted in your compressor, switch the main switch back on.

The following now appears on the display:

```
GARDNER DENVER  
SETUP-CODE 1: 0000
```

You will find the setup codes on a sticker (see Fig. 3) in the compressor switch panel (see Fig. 4). You can now use the \downarrow or \uparrow keys to enter the first setup code. Please confirm your entry using the \ominus key. The whole process now has to be repeated twice for codes 2 and 3.

If you have entered a code incorrectly, the indication immediately jumps back to code 1. You then have to re-enter all three codes.

If you have correctly entered the codes, the machine will have automatically been switched to its delivery status.

The language has now been reset to English. If you need a different language, please set this as described in section 2.1.

You now have to set the maximum and minimum supply pressure. You will find the precise description for this process in the Default settings section.

You then have to repeat the individual programming for the inputs and outputs. Consult your compressor's circuit diagram for this. It contains information about how the inputs and outputs were programmed.

The Menu section [OPTIONAL IN-/OUTPUTS] contains an accurate description of how to program inputs and outputs.

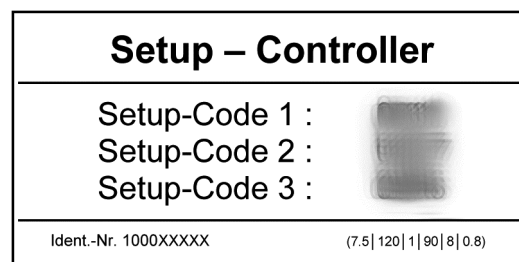

Fig. 3 Setup code sticker

Sticker

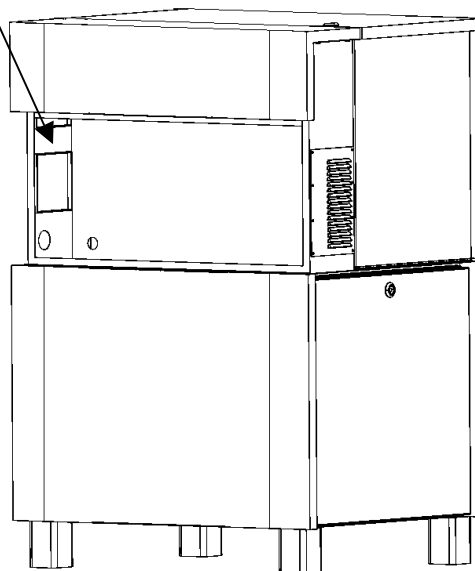

Fig. 4 Compressor with open switch panel

5.8 Remote control

5.8.1 Remote control for pressure changeover

Danger

In this operating mode, the compressor may start automatically at any time.

Attention

Only potential-free contacts may be connected to the terminal strip. External voltages will destroy the GD PILOT.

The potential-free contacts must not be more than 20 metres away from the terminal strip. If necessary coupling relays must be fitted in the control cabinet.

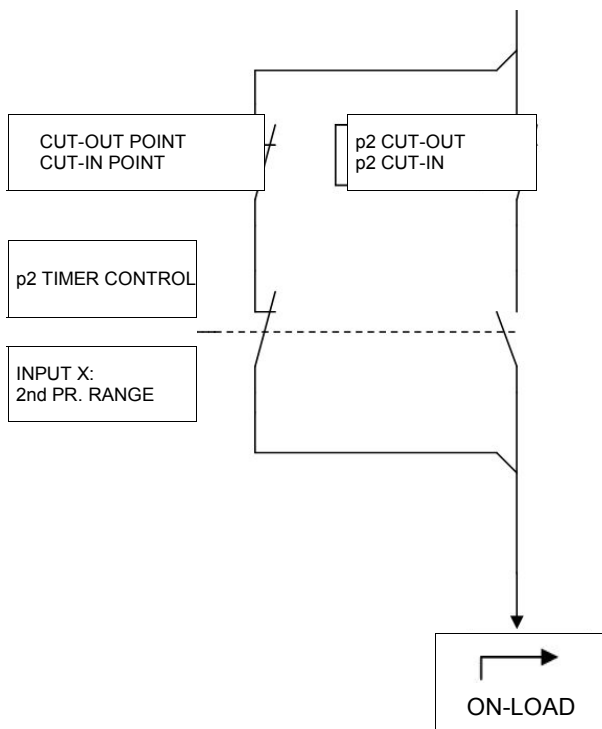

Fig. 5 Circuit diagram for pressure changeover.

Sections 5.1.2 and 5.3.2 contain explanations of how to set the second pressure range and the possibility of - timer operations with the second pressure range.

But you can also activate the second pressure range remotely. This is done using a digital input (input X in Fig. 5) on the GD PILOT (see section 5.5.1 and circuit diagram).

In the [OPTIONAL IN-/OUTPUTS] menu you have to program the inputs using the 2nd PR. RANGE function.

A potential-free contact can now be connected to the terminal strip of the programmable input. If this contact is closed, the system changes over to the second pressure range.

You can also use this contact to take the programmed timer for the second pressure range out of service.

5. Extended functions

5.8.2 On-load/off-load remote control

Danger

In this operating mode, the compressor may start automatically at any time.

Attention

Only potential-free contacts may be connected to the terminal strip. External voltages will destroy the GD PILOT.

The potential-free contacts must not be more than 20 metres away from the terminal strip.

If necessary coupling relays must be fitted in the control cabinet.

The GD PILOT control system allows the operator to switch the compressor into on-load or off-load from a remote point through the connection of two potential-free contacts. This function is needed when using an external control for example.

To do this, go to the [OPTIONAL IN-/OUTPUTS] menu where you must program one input with the ENAB. REM. LOAD function and another with the

REMOTE LOAD function. The unit can now be switched to on-load or off-load using these two inputs.

You will find a circuit diagram in Fig. 6. In our explanation, we have assigned the inputs as follows:

INPUT 1: ENAB. REM. LOAD

INPUT 2: REMOTE LOAD

You can of course program the inputs any way you choose.

If input 1 is activated, the unit can only be switched into on-load or off-load by remote control. Both pressure ranges and time control mode are interrupted (decoupled). If input 2 is now activated, the machine is in on-load. If input 2 is not activated, the machine is in off-load.

If the supply pressure exceeds the preset operating pressure of 0.5 bar, the WARNING LINE PRESS indication appears on the display. Remote control is deactivated at the same time. The unit now runs again using one of the preset pressure ranges until the WARNING LINE PRESS is acknowledged.

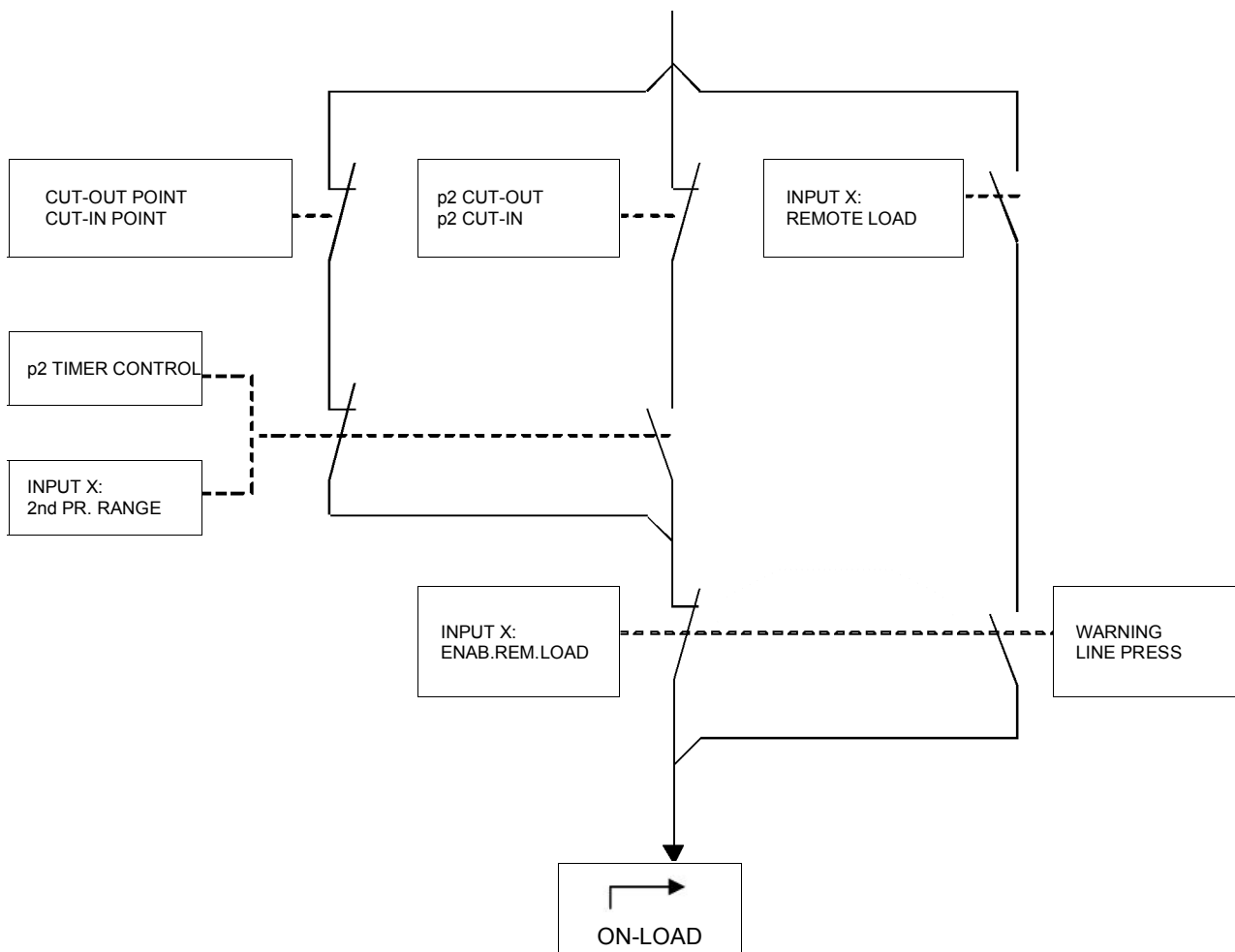

Fig. 6 On-load/off-load remote control circuit diagram

5. Extended functions

5.8.3 Remote start / stop

Danger

In this operating mode, the compressor may start automatically at any time.

Attention

Only potential-free contacts may be connected to the terminal strip. External voltages will destroy the GD PILOT.

The potential-free contacts must not be more than 20 metres away from the terminal strip. If necessary coupling relays must be fitted in the control cabinet.

This function allows the operator to externally switch the compressor on and off. You have two ways of implementing this function. The remote start / stop function is permanently programmed. This relates to terminals X2:1 and X2:3 (see circuit diagram).

The unit continues to run while the potential-free contact is closed. If the contact is opened, the soft-stop is undertaken and the unit stops.

Note

The unit is controlled using the remote start / stop function. If the unit is shut down during operations, e.g. due to power loss, it does not automatically start up when the power is restored. The potential-free contact must first be re-opened and then closed to restart the unit.

1st option

The compressor is to be activated using a potential-free contact.

You activate this function in the [CONTROL MENU] sub-menu. Please go to the ENABLE REMOTE-START menu item. Once you have pressed the \ominus key, the OFF value starts to flash. You can now use the \oplus key to change the value to ON. The \otimes symbol appears in the first display row.

Please connect the potential-free contact that you need for the remote start / stop function to the X2:1 and X2:3 terminals. This input is permanently programmed for the remote start / stop function.

If the remote start / stop function is activated, you can no longer control the machine using the On \odot and \odot keys on the GD PILOT. Only the emergency off button remains activated. The machine can now only be switched on and off using the potential-free contact.

2nd option

A control room is to decide whether the enable for the remote start / stop function is issued. The function for the enable is implemented using a digital input. If the enable is issued, the compressor can only be switched on and off using the external potential-free contact (X2:1 and X2:3). If the enable is not issued, the compressor can only be switched on and off on the GD PILOT.

Please connect the potential-free contact that you need for the remote start / stop function to the X2:1 and X2:3 terminals. This input is permanently programmed for the remote start / stop function.

In the [OPTIONAL IN-/OUTPUTS] menu you now have to program one input with the ENAB.REM-START function (see section 5.5.1).

The \otimes symbol appears in the first display row. In the [CONTROL MENU] sub-menu behind the ENABLE REMOTE-START menu item, EXT. appears.

If the input is closed, the unit can only be switched on and off using the potential-free contact.

If the input is opened, the unit can only be switched on and off using the GD PILOT.

6. Error rectification

6.1 Warnings

Warning messages are shown in the 3rd display row. The red light signal on the GD PILOT also flashes slowly.

Warning messages do not result in the compressor shutting down. However ignored warnings may cause faults.

6.2 Faults

In order to protect the unit, all detected faults result in the compressor shutting down immediately or do not permit the compressor to be started.

The faults are shown in the third display row. The red light signal on the GD PILOT also flashes quickly.

Faults have to be rectified before the start and then acknowledged using the \ominus key. The unit can now be started again.

6.3 Checklist

Loose connections, connection plugs, defective power supplies or non-observance of the installation notes generally result in a large number of error patterns. It is therefore not unusual for the errors shown to be traced back to another cause.

Please therefore always observe the following checklist:

1. The unit's supply voltage must be within the permissible limits.
2. The control transformer must be set to any local - deviating mains voltages (see circuit diagram).
3. The switch panel temperature must not exceed 55 °C.
4. All remote controls fitted at a later date (remote On/Off) must be managed without a connection relay at max. 20 metres from the control cabinet.
5. When commissioning and carrying out maintenance work, check that all connections screws and plugs are tight.
6. The power supply must have an adequate cross-section. When designing the cable, please therefore note the type of routing, cable length and the conductor temperatures expected.
7. When retrofitting switching devices, the control transformers must never be 'tapped' as they could be overloaded.

8. Only ever use genuine Gardner Denver spare parts.
9. Do not connect up extra switching or measurement - devices without the consent of Gardner Denver.
10. Do not route any measurement recorders out of the unit.
11. If you have any technical queries, have the following information to hand to assist with a quick and specific fault rectification:
 - Unit type / product number
 - Order number
 - Circuit diagram drawing no. and ID
 - Information about the unit's operating conditions
 - Information about the accessories your fitted later on (remote controls etc.)
 - Other conversions/add-ons on your unit undertaken later on
 - An accurate description of the fault that has occurred.

6.4 Table of faults / warnings

The next few pages contain the fault table for the GD PILOT, the possible causes of faults and suggestions on how to remedy them.

6. Error rectification

[Indication] / Problem	Possible cause	Remedy
FAULT POWER LOSS	Power loss	Find cause
	Voltage dip	Find cause
	Cabling damaged	Check, repair if necessary
	Loose terminals	Check that all connecting terminals and plugs are tight, retighten if necessary
FAULT EM-STOP	Emergency off is being/has been activated	Unlock
	Emergency off switch defective	Check, replace if necessary
	Cabling damaged	Check, repair if necessary
FAULT MOTOR TEMP	Motor has been started too often	Limit number of starts/hour
	Insufficient motor cooling	Improve
	Excessive power consumption	Check, find cause
	Defective power supply	Check, find cause
	Motor defective	Check, replace if necessary
	Contactor-type star delta starter defective	Check, repair if necessary
FAULT COMP TEMP	Final compression temperature exceeded ⁽¹⁾	Find cause
WARNING HIGH TEMP	Approach temperature too high	Improve
	Defective cooling	Improve
	Unit being operated with enclosure open	Close enclosure
	Oil injection volume/temperature too low/high	Check, find cause
	Incorrect oil grade/viscosity	Check, replace oil if necessary
	R2 temperature sensor defective (indication too high)	Check, replace if necessary
FAULT START TEMP	Start attempt at too low a temperature ⁽¹⁾	Heat up compressor room
	R2 temperature sensor defective (indication too low)	Check, replace if necessary
WARNING HIGH PRESS	Operating pressure exceeded by 1.0 bar / 14 psi ⁽¹⁾	
FAULT OVER PRESS	Operating pressure exceeded by 1.5 bar / 21 psi ⁽¹⁾	
	Pressure losses in the system too high	Check, find cause
	Network pressure switching points ⁽⁴⁾ too high	Correct
	External pressure requirement too high	Check remote on-load/off-load switching points
	Intake controller not closing	Check, find cause
	Pressure sensor B1 or B2 defective (incorrect indication)	Check, replace if necessary
FAULT SENSOR B1	Faulty supply pressure sensor	
	Pressure and/or temperature sensor defective	Check, replace if necessary
	Cabling to sensor damaged	Check, replace if necessary

6. Error rectification

[Indication] / Problem	Possible cause	Remedy
FAULT SENSOR B2	Faulty final compression pressure sensor Pressure and/or temperature sensor defective Cabling to sensor damaged	Check, replace if necessary Check, replace if necessary
FAULT SENSOR R2	Faulty final compression temperature sensor Pressure and/or temperature sensor defective Cabling to sensor damaged	Check, replace if necessary Check, repair if necessary
FAULT DIRECT ROT	Drive motor running in wrong direction (see circuit diagram)	Connect up correct phase sequence
FAULT MAINT PER	Shutdown maintenance ⁽²⁾ activated and maintenance interval exceeded by 100 hours ⁽²⁾	Carry out maintenance and reprogramme interval
FAULT HEAVYSTART	Final compression pressure too high during motor's start phase ⁽¹⁾ .	Check whether intake controller is closing in sealed manner.
FAULT EXT FAULT	Shutdown resulting from external fault (monitored by INPUT: EXT FAULT ⁽³⁾)	Check, find cause.
WARNING EXT WARNING	Warning from external device (monitored by INPUT: EXT WARNING ⁽³⁾)	Check, find cause
FAULT BEKOMAT FAULT	Connected condensate drain valve (Bekomat) defective ⁽³⁾ .	Check, find cause.
WARNING BEKOMAT WARN.	Connected condensate drain valve (Bekomat) defective ⁽³⁾ .	Check, find cause.
WARNING DRYER WARNING	There is an external dryer error ⁽³⁾	Check dryer
FAULT DRYER FAULT	There is an external dryer error ⁽³⁾	Check dryer
FAULT GD PILOT	GD PILOT hardware error	Replace GD PILOT electronics
WARNING TIMER	The real timer's accumulator is flat	The real timer must be reset (see section 2.3).
WARNING INPUT 1 WARNING INPUT 2 WARNING INPUT 3 WARNING INPUT 4 WARNING INPUT 5	One of the reserve inputs 1..5 has been activated, but is programmed as FREE.	Check the assignment of the input in question. ⁽³⁾
GARDNER DENVER SETUP-CODE 1:____?	GD PILOT hardware error	GD PILOT electronics must be replaced, as an emergency remedy: enter setup codes, check all settings and reset if necessary ⁽²⁾⁽³⁾⁽⁴⁾⁽⁵⁾
A fault/warning cannot be acknowledged	Fault/warning still in place	Find cause and remedy
No indication on the display	Machine not energised	Check fuses, replace if necessary
Unit not automatically starting after power loss	AUTO RESTART function not activated Power loss lasted too long ⁽⁴⁾	Activate ⁽⁴⁾

6. Error rectification

[Indication] / Problem	Possible cause	Remedy
Unit runs continuously in off-load without independently switching to readiness (standby)	CONTINUOUS OPERATION operating mode selected ⁽⁴⁾ Very brief pressure requirements during the run-on time	Select AUTOMATIC OPERATION operating mode
No compressed air requirements within the switching points set ⁽⁴⁾	Pressure changeover by timer or external contact active ⁽⁵⁾	

- (1) Unit-specific setting: see 5.4 [LIMIT VALUES] menu
(2) Individual setting: see section 4 [MAINTENANCE SCHED.] menu
(3) Individual setting: see section 5.5 [OPTIONAL IN-/OUTPUTS] menu
(4) Individual setting: see section 5.1 [CONTROL MENU] menu
(5) Individual setting: see section 5.3 [TIMER CONTROL] menu



**Gardner Denver Compressor Division,
1800 Gardner Expressway, Quincy, Illinois 62305**

**Telephone: (800) 682-9868
Fax: (217) 224-7814**

**Gardner Denver Deutschland GmbH
Argenthaler Str. 11
55469 Simmern
Deutschland**

**Tel. ++49 (0)6761 832-0
Fax ++49 (0)6761 832-409**