



General Pneumatics

Installation, Operating and Maintenance Manual

TKF SERIES REFRIGERATED AIR DRYERS

Air-Cooled Models

**TKF200A
TKF250A
TKF325A
TKF400A
TKF500A
TKF600A
TKF800A
TKF1000A
TKF1200A
TKF1500A**

Water-Cooled Models

**TKF200W
TKF250W
TKF325W
TKF400W
TKF500W
TKF600W
TKF800W
TKF1000W
TKF1200W
TKF1500W**

**This instruction manual must be read by everyone
who installs or works with this equipment.**

TABLE OF CONTENTS

INTRODUCTION	1
SAFETY	1
Safety Instructions	1
Safety Labels	1
Data Plate	1
RECEIVING AND INSPECTION	1
Handling	2
Returns to Manufacturer	2
INSTALLATION	2
Ambient Air Temperature	2
Location and Clearance	2
System Arrangement	2
Piping and Connections	2
Cooling Water Piping	2
Cooling Water	3
Water Quality Recommendations	3
Air-Cooled Models	4
Condensate Drain	4
Field Power Supply	4
HOW IT WORKS	5
Airflow	5
Refrigeration System	5
ELECTRONIC SYNOPTIC CONTROLLER	5
Indicators	5
Key Pad Buttons	6
Display Screens	6
Configuring the Controller	6
Warning Messages	7
Alarm Messages	7
Additional Delay Times	7
Remote Communication	7
OPTIONS	7
START-UP AND OPERATION	7
Preliminary Start-Up	7
Start-Up (Air-Cooled Units Only)	8
Start-Up (Water-Cooled Units Only)	9
High Altitude Dryer Hot Gas Bypass Valve Adjustment Procedure	9
SHUTDOWN	10
MAINTENANCE	10
Condensate Drain Valve	10
Air-Cooled Condenser Coil	11
Compressed Air Prefilter	12
Refrigeration	12
TROUBLESHOOTING	17
ELECTRICAL SCHEMATICS	19
REPLACEMENT PARTS	24

INTRODUCTION

TKF refrigerated air dryers use mechanical refrigeration to dry compressed air to pressure dew points as low as 33°F - 39°F. They deliver the required dew point at specified inlet air temperature, pressure and airflow. Any change in these operating conditions may affect performance. See Tables VII and VIII (page 22) for rated capacity and other dryer specifications.

Compressed air systems commonly require filters to remove compressor oils, particulates, condensed liquids and other contaminants. When an oil-removal filter is used, install the filter downstream of the TKF dryer. At this location, the life of the replaceable filter element is prolonged since some of the entrained oil is removed by the dryer and drained through the separator.

To ensure continuing good performance and safe operation of the dryer, everyone who installs, uses or maintains the dryer must read and carefully follow the instructions in this manual.

SAFETY

TKF refrigerated air dryers are designed and built with safety as a prime consideration; industry-accepted safety factors have been used in the design. Each dryer is checked at the factory for safety and operation. All necessary adjustments are made before shipment.

Follow the maintenance schedules outlined in this manual for good performance and safe operation. Maintenance should be done only by qualified personnel with proper tools.

Carefully read the following safety rules before proceeding with installation, operation or maintenance. The rules are essential to ensure safe dryer operation. Failure to follow these rules may void the warranty or result in dryer damage or personal injury.

1. Do not install or try to repair a dryer that has been damaged in shipment. See Receiving and Inspection for instructions.
2. Compressed air and electricity have the potential to cause personal injury or equipment damage. Before doing any work on the dryer, be sure the electrical supply has been locked and tagged and the internal pressure of the dryer has been vented to the atmosphere.
3. Do not operate the dryer at pressures or temperatures above the maximum conditions shown on the data plate.
4. Always supply electrical power that complies with the voltage shown on the data plate.

5. Do not readjust the dryer without factory authorization.
6. Work on the refrigeration system must be done only by a competent refrigeration mechanic.
7. Use only manufacturer's genuine replacement parts. The manufacturer bears no responsibility for hazards caused by the use of unauthorized parts.

Safety Instructions

Safety instructions in this manual are boldfaced for emphasis. The signal words **DANGER**, **WARNING** and **CAUTION** are used to indicate hazard seriousness levels as follows:

DANGER—Immediate hazard which **WILL** result in severe injury or death.

WARNING—Hazard or unsafe practice which **COULD** result in severe injury or death.

CAUTION—Hazard or unsafe practice which **COULD** result in minor injury or in product or property damage.

Safety Labels

Dryer labels provide important safety information. If any label is damaged, contact your local distributor to request a replacement.

Data Plate

The dryer data plate contains critical safety and identification information. If the data plate is missing or damaged, contact your local distributor and request a replacement.

RECEIVING AND INSPECTION

Inspect the dryer closely when it is received. Record any indication of damage on the delivery receipt, especially if the dryer will not be immediately uncrated. Obtain the delivery person's signed agreement to recorded damages to facilitate future insurance claims.

Since the dryer is shipped F.O.B. New Castle, Delaware, the manufacturer's responsibility for the shipment ceases when the carrier signs the bill of lading.

If goods are received short or in damaged condition, notify the carrier and insist on a notation of the loss or damage across the face of the freight bill. Otherwise no claim can be enforced against the carrier.

If concealed loss or damage is discovered, notify your carrier at once and request an inspection. This is absolutely necessary. Unless you do this the carrier will not consider any claim for loss or damage. The carrier will

make an inspection and may grant a concealed damage notation. If you give the carrier a clear receipt for goods that have been damaged or lost in transit, you do so at your own risk and expense.

The manufacturer is willing to assist you in collecting claims for loss or damage. Willingness does not make the manufacturer responsible for collecting claims or replacing material. Claim filing and processing is your responsibility.

Handling

The dryer is mounted on a base to facilitate moving it with a forklift. Forks should extend all the way through the forklift channels provided to reduce stress on the dryer frame. If slings are used to move the dryer, use spreader bars to prevent damage to the sides of the dryer.

Returns to Manufacturer

If a dryer or dryer component must be returned to the manufacturer, first call your local distributor for a return authorization number and shipping address. Your distributor will inform you whether the dryer or only a component must be returned. Mark the package with the return authorization number and ship freight prepaid as directed by the distributor.

INSTALLATION

Ambient Air Temperature

Locate the dryer indoors where the ambient air temperature will be between 40°F and 100°F. Intermittent operation at ambient temperatures up to 120°F will not damage the dryer but may result in a higher dew point or dryer shutdown due to high refrigerant discharge pressure (see Field Service Guide). Call your local distributor if prolonged operation at ambient temperatures above 100°F or below 40°F is unavoidable.

Do not operate air-cooled dryers at ambient air temperatures below 40°F. Such operation may result in low suction pressure, causing freeze-up.

Do not operate dryers with the "K" (weatherproof) option outdoors in ambient temperatures below 40°F.

Location and Clearance

Mount the dryer on a level base and bolt it down if the base vibrates. Install the dryer in a clean, well ventilated area to reduce fouling of the condenser coils with dirt and dust. Allow 24 inches clearance on the sides and front of the dryer for cooling airflow and for service access.

System Arrangement

Liquid water adversely affects dryer performance. To prevent "slugging" the dryer with liquid water, locate the dryer downstream of an aftercooler and a mechanical separator. Install drain valves to discharge condensate that collects in these areas.

If the airflow is relatively constant and will not cause short term overloading of the dryer, it is recommended that the dryer be located downstream of the receiver tank. If the nature of the application is such that the air demand regularly exceeds the dryer flow rating, it is recommended that the dryer be located upstream of the receiver.

For safety and convenience, install inlet and outlet shut-off valves and depressurization valves. These valves allow the dryer to be isolated and depressurized for servicing. Bypass piping may be installed around the dryer for uninterrupted airflow when the dryer is serviced. If the compressed air operation cannot tolerate undried air for short periods, install a second dryer in the bypass line.

Piping and Connections

Piping must be furnished by the user unless otherwise specified. Connections and fittings must be rated for the maximum operating pressure given on the dryer data plate and must be in accordance with applicable codes. Support all piping; do not allow the weight of any piping to stress the dryer or filters. Proper sizing of piping should be determined using good engineering practice. See page 22 for dryer inlet and outlet connections.

All TKF air dryer air-in and air-out connections are clearly marked. When piping in, flexible connections (vibration isolators) or union joints are recommended to avoid piping stresses and vibration transmission.

The primary function of your dryer is the removal of water from your compressed air system in order to attain the required dew point. This is best accomplished with clean internal heat exchanger surfaces. Although the TKF dryer heat exchanger has been designed to minimize fouling, the installation of a coalescing prefilter located ahead of the dryer is strongly recommended. The prefilter with automatic drain valve will remove oil, dirt, scale, etc., which may be present in the compressed air before it reaches the dryer, thereby minimizing overall dryer operating costs.

Cooling Water Piping

All TKF water-cooled units are factory piped for city water and supplied with an automatic water regulating valve which must be set on location, with constant wa-

ter pressure to maintain proper head pressure under all load conditions.

Water supply pressure should be maintained at no less than 25 psig.

Cooling Water

Required water flow rate depends on water temperature (refer to Table I). The valve supplied with the dryer automatically adjusts the flow to compensate for variations in water temperature, water pressure and dryer air load.

Operating the dryer with inadequate condenser cooling water (temperatures above or pressures below those in Table I) will cause a rise in dew point unless the dryer inlet air flow is reduced. The refrigerant discharge pressure control will shut down the refrigerant compressor if cooling water is inadequate.

If the cooling water is dirty, install a strainer ahead of the condenser inlet. Install shut-off valves so that the strainer can be drained and cleaned at regular intervals.

Table I
COOLING WATER REQUIREMENTS

DRYER MODEL	WATER CONN. (inches NPT)	COOLING WATER REQUIRED ^a (gpm)				
		60°F	70°F	80°F	85°F	90°F
TKF200W	3/8	0.6	0.8	1.1	1.5	2.0
TKF250W	3/8	0.4	0.7	1.1	1.5	2.1
TKF325W	3/8	0.7	1.0	1.6	2.3	3.5
TKF400W	3/8	0.6	1.0	2.1	2.7	4.2
TKF500W	1/2	1.6	2.0	2.8	3.8	5.5
TKF600W	1/2	1.6	2.0	2.8	3.8	5.5
TKF800W	1/2	1.5	2.0	3.7	5.4	10.0
TKF1000W	1/2	2.5	3.0	4.5	5.7	9.0
TKF1200W	1	6.0	7.0	8.0	10.0	12.0
TKF1500W	1	8.0	9.0	11.0	14.0	16.0

^a Minimum water pressure is 25 psig for city water and 35 psig for tower water. Maximum water pressure is 150 psig.

Water Quality Recommendations

Water quality is often overlooked when the cooling system of a water cooled dryer is examined. Water quality determines how effective the heat transfer rate and flow rate will remain during the operation life of the dryer. The quality of water used in any cooling system does not remain constant during the operation of the system. The water makeup is affected by evaporation, corrosion, chemical and temperature changes, aeration, scale and

biological formations. Most problems in a cooling system show up first in a reduction in the heat transfer rate, then in a reduced flow rate and, finally, with damage to the system.

If the cooling water is dirty, install a strainer ahead of the condenser inlet. Install shutoff valves so that the strainer can be drained and cleaned at regular intervals. There are many constituents in the water system that must be balanced to have a good stable system. The following are the major components that should be monitored:

Corrosion

Corrosion problems may be caused by: chlorides, low pH levels and high levels of dissolved oxygen. These conditions should be monitored and treated as necessary to prevent corrosion.

Scale

Scale formation will help to prevent corrosion. Therefore, a thin uniform coating of calcium carbonate is desired on the inner surfaces of the cooling system. However, in excess, scale formation will inhibit effective heat transfer.

One of the largest contributors to scale formation is the precipitation of calcium carbonate out of the water. This is dependent on temperature and pH. The higher the pH value, the greater the chance of scale formation. Scale can be controlled with water treatment.

Fouling

Biological and organic substances (slime) can also cause problems, but in elevated temperature environments such as cooling processes they are not a major concern. If they create problems with clogging, commercial shock treatments are available.

To ensure continuing good operation and performance of the dryer cooling system, the recommended acceptable ranges for different water constituents are shown in Table II.

Table II
Water Quality Requirements

PARAMETER	CONCENTRATION	FREQUENCY OF ANALYSIS
Corrosivity (Hardness, pH, total dissolved solids, temperature at inlet, alkalinity)	Langelier Index 0 to 1	Monthly If stable for 3 to 4 months, analyze quarterly
Iron	<2 ppm	Monthly
Sulfate	<50 ppm	Monthly
Chloride	<50 ppm	Monthly
Nitrate	<2 ppm	Monthly
Silica	<100 ppm	Monthly
Dissolved oxygen	0 ppm (as low as possible)	Daily If stable for several days, analyze weekly
Oil and grease	<5 ppm	Monthly
Ammonia	<1 ppm	Monthly

Air-Cooled Models

Cooling air must be drawn from a clear, well-ventilated area to reduce dust and dirt accumulation on the condenser coils. Air temperature should not exceed 100°F. Required air flow rates are shown in Table III.

Table III
COOLING AIR REQUIREMENTS

MODEL	COOLING AIR (cfm)
TKF200A	1,400
TKF250A	1,400
TKF325A	1,400
TKF400A	3,000
TKF500A	2,700
TKF600A	2,700
TKF800A	5,200
TKF1000A	4,800
TKF1200A	5,000
TKF1500A	5,800

Condensate Drain

Condensate must be drained from the dryer to prevent its reentrainment. Dryers are equipped with timed electric drains. A condensate hose is coiled and secured inside the dryer cabinet for shipping. Uncoil the hose and run it to a waste disposal collection system that meets

applicable regulations. Pipe or copper tubing ½-inch or larger is recommended for condensate discharge lines. Do not use ¼-inch or ⅝-inch O.D. Flexible tubing unless the discharge line is shorter than 10 feet. Install the discharge lines so that condensate can be seen as it drains.

Prior to start-up, ensure that the drain is properly connected and that the manual ball valve is open.

Note
After first 24 hours of initial operation, inspect and clean the strainer and drain.

Even newly installed air systems contain dirt and oil which could clog the strainer or foul the drain valve. Left unchecked, this situation would prevent proper separator operation.

Without proper separator operation, water cannot be removed from the compressed air stream. Therefore, the drain and strainer should be inspected regularly. (See Maintenance.)

Field Power Supply

All TKF units use copper conductors (only) and should be sized in accordance with the customer supplied horsepower rated fuse. Check your local codes to provide the appropriate disconnect switch (or breakers).

Note
Use proper load rated components as approved by NEC, NEMA, CSA, UL, etc., as required according to local and municipal codes. All installations and connections must be in accordance with recognized electrical codes in effect.

All field power wiring and connections must be terminated inside the main electrical enclosure. Remove right side panel and electrical enclosure cover to gain access to terminal strip. Customer terminal strip is clearly marked "ITS." Installation of all conduit and connectors to the dryer is the responsibility of the customer.

All TKF dryers are equipped with prewired crankcase heaters as a standard feature. The crankcase heater should be energized for a minimum of 12 hours prior to initial start-up or after any prolonged shutdown.

CAUTION
Operation of dryers with improper line voltage constitutes abuse and could affect dryer warranty.

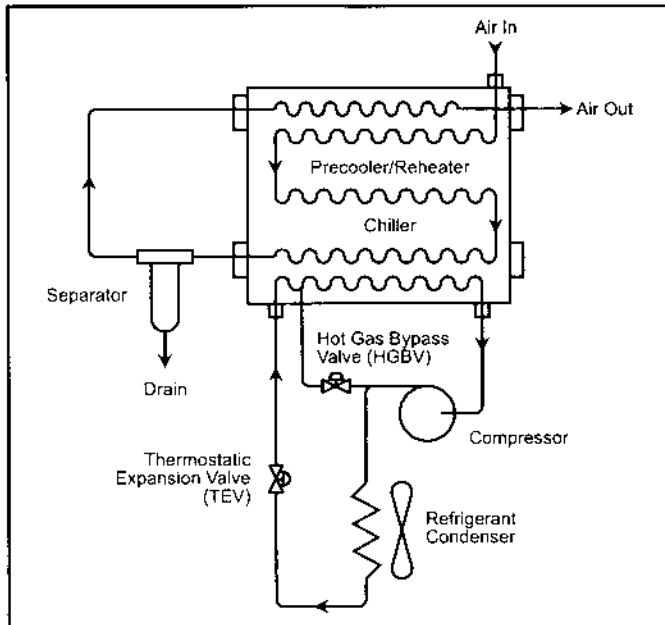

Figure 1
Air and refrigerant flow schematic

Note

The dryer field power wiring **MUST** be independent of the air compressor so it does not cycle off/on in conjunction with the compressor. Consult factory for any special conditions or requirements.

All three (3) phase units should have a phase protector installed on power supply to unit.

Chassis must be properly earth grounded. Only qualified electricians should connect dryer to customer power.

HOW IT WORKS

Airflow

TKF dryers use refrigeration cooling to condense entrained moisture out of the airstream (refer to Figure 1). Warm saturated air enters the heat exchanger where it is cooled by outgoing cold air. The inlet air is further cooled by refrigeration causing water vapor to condense to a liquid so it can be removed. Condensate is removed by a centrifugal separator and an automatic drain.

Refrigeration System

The refrigeration system is designed and fabricated in accordance with recognized commercial/industrial practices. It consists of a compressor and the controls, safety

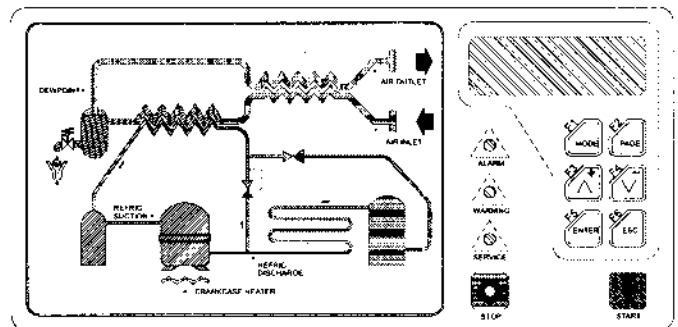

Figure 2
Electronic Synoptic Controller Display Panel

interlocks and associated equipment necessary for safe performance.

The refrigerant valves are adjusted at the factory; operation is fully automatic.

ELECTRONIC SYNOPTIC CONTROLLER

TKF dryers are equipped with a fiber optic Electronic Synoptic Controller. The controller manages all operations of the dryer, monitors all dryer functions, diagnoses machine faults and protects the unit by shutting down the dryer in the event of a major problem.

The controller has an LCD (alphanumeric display), status indicators (alarm, warning, and service) and a touch sensitive keypad. These features provide:

- access to critical dryer operating conditions for monitoring and diagnosing
- adjustment of the condensate drain valve on the separator
- operating, warning, alarm and service indicators.
- Refer to the Troubleshooting section on page 15 for controller troubleshooting information.

Indicators

The following indicators are provided on the controller (refer to Figure 2).

ALARM

The red ALARM indicator lights indicating a need for immediate attention. The alarm message will display on the LCD. The dryer will shut down until the alarm condition is corrected. The dryer must be manually restarted after recovering from an alarm condition.

WARNING

The yellow WARNING indicator lights indicating a problem condition is occurring. The warning message

will display on the LCD. It is not necessary to manually reset the dryer.

SERVICE

The yellow SERVICE indicator lights indicating service is due. The LCD will display the service information.

Key Pad Buttons

The functions of the key pad buttons on the controller are as follows:

F1(MODE)

The MODE key is used to view (scroll through) the first page of each of the display screens described in the Display Screens section.

F2(PAGE)

The PAGE key is used to view the next page of the selected display screen.

F3(+) and F4(-)

The minus and plus keys are used to adjust a value, such as the drain cycle time. Press F5(ENTER) to display the cursor. Then use F3(+) or F4(-) to adjust the value.

Note

To cancel the change and restore to the original value, press the F6(ESC) key while the cursor is flashing.

F5(ENTER)

The ENTER key is used to display the cursor when changing a value and to save the changes when complete.

F6(ESC)

The ESC key will cancel changes and restore the original value. If the cursor is not flashing, press the ESC key to return to the first status screen.

START

The START key can be used to start dryer operation.

STOP

The STOP key can be used to stop dryer operation.

Display Screens

The screens can be displayed in English, French and Spanish. Use the configure screen to change the display screen language.

Status

The status display screen displays the current operating information, such as normal operation, warming up, warning, alarm, or service condition.

Temperatures

The temperature display screens show the dew point, air inlet, air outlet, refrigerant suction and crankcase heater temperatures. Temperatures can be displayed in Fahrenheit or Celsius.

Pressures

The pressure display screens (if the pressure package is installed) show the air outlet, air inlet, refrigerant suction and refrigerant discharge pressures. Pressures can be displayed in psi, kPa or bar.

Drain

The drain display screens show the drain cycle time and the drain purge time. Press the F4(-) key to manually operate the drain valve and verify proper operation.

To adjust the drain times:

1. Press the F5(ENTER) key to show the cursor.
2. Use the F3(+) and F4(-) keys to adjust the value.
3. Press the F5(ENTER) key again to save the new value. Note: Pressing the F6(ESC) key will cancel the change and restore the original value.

History

The history display screens show the alarm and warning history, the total run-time and the power on time for the dryer. The alarm history can be cleared (refer to "Configuring the Controller").

Service

The service display screens show the number of effective use hours left on the filter and the number of hours left before a service call is due. The service representative information is also displayed. A controller LED test can also be performed from this screen by pressing F5(ENTER).

Configure

The configure display screens can be used to change the following:

- service representative information that will display when an alarm or warning condition occurs
- display language (English, Spanish or French)
- temperature unit (Fahrenheit or Celsius)
- pressure units (psi, kPa or bar)
- baud rate (300, 1200, 2400 or 4800) and RS232/485 if remote communication is being used.

Configuring the Controller

To restore all values to the default values:

1. Shut down the dryer.

2. Press and hold the F1(MODE) and F4(-) keys simultaneously while starting the dryer. This performs a “first start.”
3. Release the buttons after the first menu appears on the display.

To clear the alarm history:

1. Go to the History screen.
2. Press F1(MODE) and F4(-) simultaneously.

To reset the filter and service times to zero:

1. Press F3(+) and F4(-) simultaneously to clear the currently displayed service screen.
2. Repeat step 1 for each service screen to reset the desired service times.

To change the display language, temperature unit, pressure unit, or baud rate:

1. From the Configure screen, press the F5(ENTER) key. This will show the cursor.
2. Press the F3(+) key or the F4(-) key to change the selection to the desired unit.
3. Once the correct unit is displayed, press the F5(ENTER) key to save the change.

Warning Messages

When a warning occurs, the yellow warning indicator on the controller will light and the display will show the warning message.

An ice warning condition will temporarily shut down the compressor until the dew point temperature returns to normal range. It is NOT necessary to manually restart the dryer.

Refer to Table IV for a description of the warning messages.

Alarm Messages

When an alarm occurs, the red alarm indicator on the controller will light and the display will show the alarm message.

Alarm conditions will shut down the compressor. Once the condition is corrected, the START button must be pressed to restart the dryer.

Refer to Table IV for a description of the alarm messages.

Additional Delay Times

Additional conditions that will cause a delay are:

- If the compressor is shut down for any reason – one minute compressor cycle delay.
- Initial time between drains – 30 second delay

Remote Communication

Installing the Remote Communication

The 9-pin serial connection (P22) is located at the bottom left side of the low voltage board.

To access the low voltage board:

1. Remove the front panel screws to allow the front panel to tilt forward.
2. Remove four 8-32 nuts to access the low voltage board in the display enclosure.
3. For RS-485, plug adapter (P/N 1259190) into P22.
4. Plug adapter power wire into P27, marked 5V.

Configuring the Remote Communication

The following are the RS-232 pin connections for P22:

- Pin 3 — data signal to remote receiver
- Pin 5 — data to logic board from remote transmitter
- Pin 7 — ground

OPTIONS

C Option – Cold Coalescing (adds an OM Series coalescing prefilter)

F Option – Ambient filter (protects condenser face from ambient particulate matter)

K Option – Outdoor; weatherproof

P Option – Pressure package

R Option – Remote contacts for alarm conditions

S Option – Remote start/stop relay

START-UP AND OPERATION

Preliminary Start-Up

The dryer should always be started before the air compressor!

It is highly recommended that initial start-up of water-cooled units be performed by a factory-trained representative of General Pneumatics. Failure to perform proper start-up adjustments will void the factory warranty.

The following procedure is intended as a guide only and should not be considered a substitute for intimate sys-

tem knowledge. These instructions should be read in their entirety prior to any attempt to start the dryer.

Before starting the dryer the operator should:

1. Ensure there is an unobstructed flow of air over the face of the condenser (air-cooled units only).
2. Ensure cooling water is connected and shut-off valves, including the drain, are in the "OPEN" position (water-cooled units only).

6. Ensure the drain is discharging into an open system (container, funnel, etc.) to allow visual verification of proper function.

Start-Up (Air-Cooled Units Only)

Note
The section on the Electronic Synoptic Controller (ESC) should be read thoroughly before starting the dryer.

Provided the ambient temperature is within specified limits (refer to Installation), you are ready to start the dryer. Turn the main power disconnect switch to the "closed" position to energize the circuit to the dryer.

To start the unit, press the "On" button. Upon doing so, the display will indicate a warm-up or normal operating condition and the condenser fan(s) will begin to cycle (on air-cooled units only).

By opening the inlet and outlet valves and then closing the dryer bypass valve, the dryer is placed "on-stream."

Note
Water-cooled units require a minimum 25 psig water pressure, city or tower connection.

3. Ensure the relief valve on the water-cooled condenser is piped to a safe area.
4. Ensure the appropriate voltage (as specified on the data plate) is connected to the dryer and the ON/OFF switch (where applicable) is in the "OFF" position.
5. Ensure all electrical panels are replaced and secured.

Table IV Warnings and Alarms		
Message	Description	Delay Time
Warnings		
High Dewpoint ¹	Dew point temperature has exceeded 60°F	60 seconds
Ice Condition	Dew point temperature fell below 33°F (Temporarily shuts down the compressor). The dew point must reach 40°F to recover from an ice condition (the compressor will restart)	5 minutes
High Inlet Temperature ²	Inlet air temperature exceeded 120°F	60 seconds
High Suction Temperature	Refrigerant suction temperature exceeded 75°F	15 minutes
High Delta P	Filter element differential pressure exceeded; filter element needs to be changed	15 minutes
Alarms		
Low Refrigerant Pressure	Refrigerant suction pressure fell below 35 psig	15 minutes
Very High Suction Temperature	Refrigerant suction temperature exceeded 90°F	60 seconds
High Refrigerant Pressure	Refrigerant suction pressure exceeded 375 psi	—
Thermocouple Failure	Thermocouple temperature exceeded 243°F	—

¹ The displayed dew point is actually the evaporator outlet air temperature which closely follows the dew point (within 3 to 5 degrees) at full air load. At reduced air flows, this temperature may be as much as 15 degrees higher than the actual dew point. If dew point is critical, a dew point monitor should be considered.

² If inlet air temperatures fall outside the normal range, the dryer may fail to achieve the required dew point. Check the compressor aftercooler and adjust the aftercooler operation to ensure the specified inlet air temperature to the dryer.

For those units equipped with the “pressure package,” the readings (for R-22) should be:

Dew Point Temperature	33°F - 39°F*
Refrigerant Suction Temperature	38°F - 54°F
Air In Temperature	100°F (max.)
Air Out Temperature	75°F or above
Refrigerant Suction Pressure	58 - 64 psig
Refrigerant Discharge (High-Side) Pressure	190 - 295 psig
Air In Pressure	100 psig (max.)

* Dew point may be higher at less than full load.

Note

The readings obtained will be affected by volume of air flow (scfm), air temperature, condenser cooling air temperature, and ambient conditions.

Increase (decrease) capacity 6% for each 10°F lower (higher) ambient temperature or condenser air temperature. As the load increases, air-cooled units will cycle their fan(s) almost constantly and the water-cooled units will require their rated flows.

If the inlet air temperature and/or the cooling air for the condenser exceeds maximum rated temperature (100°F), the dew point at maximum air flow may exceed rated conditions.

After a period of time, condensate will be discharged from the drain.

Start-Up (Water-Cooled Units Only)

Note

The Electronic Synoptic Controller (ESC) section should be read thoroughly before starting the dryer.

1. Perform the procedure “Before starting the dryer the operator should...” on page 8.
2. Turn on the main power to the dryer at the main disconnect.
3. Ensure that the cooling water main supply valve is fully open.
4. Adjust the dryer cooling water control valve until coolant just begins to flow through the condenser.

5. Connect a refrigerant gauge manifold to the high side and low side service ports of the compressor per the manifold manufacturer’s instructions.
6. Push the “START” button on the display panel. The refrigerant compressor should now be running unless additional warm-up time is needed.
7. Adjust the dryer cooling water control valve until the refrigerant high side pressure indicates 225 psig.
8. Allow 15 minutes for the system to stabilize. View the Temperature Screen on the control panel. The panel display should indicate 38°F to 54°F.
9. Verify that the refrigerant suction pressure is 58 to 64 psig.
10. Open the air supply valves to the dryer and close the dryer bypass valves. The dew point reading will gradually drop until the dryer indicates that proper dew point has been reached by showing “run” on the display panel.
11. View the Drain Screen and press the F4(–) key on the control panel to verify proper drain valve operation.

After a period of time, condensate will be discharged from the drain.

CAUTION

Minimum water pressure at the water control valve is 25 psig. Upon installation and start-up, the water control valve is adjusted if necessary to maintain high side pressure between 215 psig and 225 psig.

High Altitude Dryer Hot Gas Bypass Valve Adjustment Procedure

Because the dryer may be installed at elevations exceeding 4000 feet above sea level, an adjustment procedure has been established to guide the installer in resetting the hot gas bypass.

The purpose of the Hot Gas Bypass Valve (HGBV) is to prevent evaporator freeze-up at low dryer loads. Hot gas metering, and therefore suction pressure, is established by the valve-spring preload at atmospheric pressure. A drop in atmospheric pressure will therefore create a corresponding drop in minimum suction pressure. To prevent evaporator freeze-up at elevations above 4000 feet, the minimum suction pressure must be increased by 2 psig.

Tools: The following tools are needed to adjust dryer suction pressure:

1. Refrigerant gauge manifold.
2. Six-inch adjustable wrench.
3. 5/16" Allen wrench.
4. Refrigeration valve service wrench.

Procedure:

Note

The following procedure must be performed by a certified refrigeration technician only. Failure to do so could void the factory warranty.

1. Gain access to the suction-line access fitting and remove the dust cap.
2. Making sure the suction valve on the refrigerant gauge manifold is closed, connect the suction pressure hose to the access fitting.
3. Start the dryer and allow the suction pressure to reach its minimum balance point. Note the minimum pressure indicated.
4. Gain access to the hot gas adjusting screw by either removing the brass cover (Sporlan) or loosening the lock nut (all others).
5. Using the appropriate tool, turn the adjusting screw in (clockwise) until the minimum suction pressure increases by 2 psig over the pressure noted in step 3.
6. When adjusted, replace cover or tighten lock nut on the valve as appropriate.
7. Disconnect gauge manifold and replace dust cap on suction access fitting.
8. Replace any access panels removed in step 1.

The proper adjustment is now complete and the dryer is ready for service. It may also now be shut down by pushing the "STOP" button.

SHUTDOWN

When dry compressed air is no longer required, you can shut down the compressor. Upon doing so, shut down the dryer by depressing the "STOP" button.

Provided no error conditions have been encountered, the dryer can now be safely left unattended until plant air is once more required.

Note

Power must be supplied to the electronic controller at all times to ensure the crankcase heater is energized while unit is in the off mode. This will allow immediate start-up of the machine after extended downtime.

MAINTENANCE

DANGER

Disconnect dryer from electrical power and lock out/tag out power supply before performing any maintenance. Some circuits in the dryer remain energized when the dryer is turned off.

Your unit, if properly installed, will operate efficiently and require very little care to provide years of dependable service. A simple routine maintenance program, consisting of several check points is all that is required.

Condensate Drain Valve

A reliable drain is critical to the design and operation of the dryer. As such, the strainer and drain should be inspected and cleaned on a regular basis. While the frequency of inspections will vary dependent upon the environmental conditions in which the machine is operating, the drain discharge should be inspected daily.

Even newly installed air systems contain contaminants such as dirt and oil. Bearing this in mind, the strainer and drain should be inspected within 24 hours of initial start-up, and cleaned if necessary. After initial start-up, the strainer and drain should be disassembled and cleaned when required.

Disassembly and Servicing

All TKF dryers have a solenoid drain valve. The valve body is mounted on the frame bottom with a Y-strainer and shut-off valve; a hose connects the assembly to the separator.

DANGER

Dismantling or working on any component of the compressed air system under pressure may cause equipment failure and serious personal injury. Before dismantling any part of the dryer or compressed air system, vent the internal pressure to atmosphere.

Routine service of the strainer can be accomplished by closing the ball valve and venting pressure by manually operating the drain valve. The strainer plug may then be removed to clean the strainer screen.

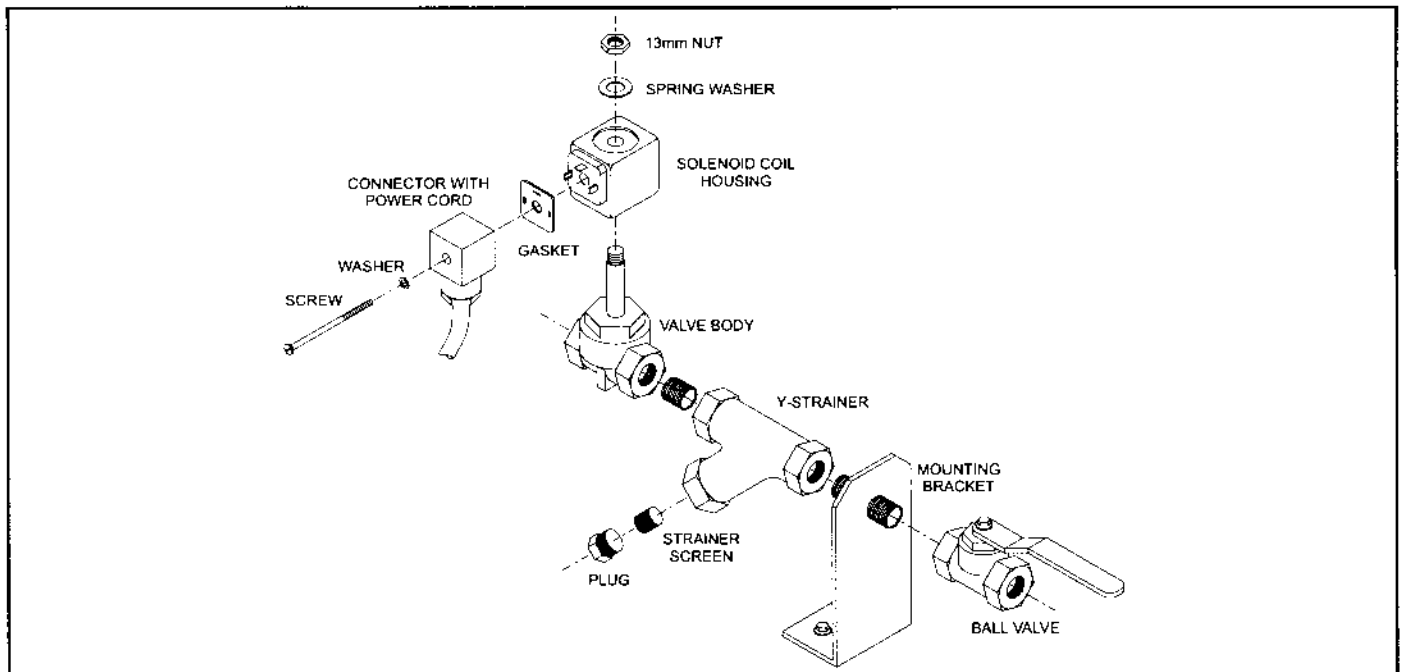

Figure 3
Drain Valve Components

The drains discharge condensate through a full-port drain opening. The valve body may need to be cleaned under conditions of gross particulate contamination.

To disassemble the drain valve body for cleaning or other maintenance:

1. Turn power switch off.
2. Disconnect main power supply to dryer.
3. Lock out and tag power supply in accordance with OSHA requirements.

WARNING

If power supply is not disconnected before disassembly, serious personal injury and valve damage may result.

4. Remove drain hose that connects the drain valve to the outlet panel.
5. Remove screw and washer from front of the drain valve.
6. Remove the power supply connector and gasket (with the timer assembly if attached) from the solenoid coil housing. Do not damage or lose the gasket.
7. Remove 13mm nut and spring washer from top of solenoid coil housing.
8. Lift solenoid coil housing off solenoid core in valve body.

9. Unscrew solenoid core from valve body.

Once the drain valve is disassembled, the following maintenance can be performed:

1. Inspect diaphragm; clean or replace as required.
2. Remove debris from valve body.
3. Wipe solenoid core components with a clean cloth or blow out debris with compressed air from an OSHA-approved air nozzle that limits its discharge pressure to 30 psig.
4. Check that small port in diaphragm is clear and solenoid coil moves freely in housing. Viton diaphragm seals are compatible with commonly used synthetic lubricants.

To reassemble the drain valve, reverse the sequence of the preceding steps. After the drain valve is reassembled, connect the main power supply to the dryer. When the dryer is returned to service, check the drain valve for air or condensate leaks; tighten connections as required to correct leaks. Check the drain cycle; adjust if necessary.

Air-Cooled Condenser Coil

The refrigeration condenser coil should be inspected and cleaned on a regular basis. As the unit runs, dirt and dust will accumulate on and between the fins as the air is drawn across and through the condenser. The result is reduced condenser efficiency due to fouling, and increased head pressure as a consequence. The resulting

increase in compressor load thus created could eventually lead to compressor damage.

The condenser should be inspected on a monthly basis when the unit is installed in a clean environment; more frequently when in a dirty environment.

When the condenser becomes fouled, compressed air should be used to remove the deposits which have accumulated on/and between the fins. To clean, carefully blow compressed air from the back side (fan side), through and towards the front of the condenser.

Note

Always EXERCISE CAUTION when using compressed air.

BE SURE TO WEAR safety glasses or an appropriate face shield when using compressed air for cleaning.

Compressed Air Prefilter

Refrigerated compressed air dryers are neither intended nor designed to remove excess oil and/or contaminants from compressed air lines. Therefore, it is recommended that a coalescing prefilter be installed on the inlet air line to the dryer.

Consult the nearest General Pneumatics Authorized Service Center if problems arise.

Refrigeration

Only authorized refrigeration technicians (using manufacturer's instructions and data) should undertake maintenance on the refrigeration section of the unit. Failure to comply with this stipulation may void the warranty.

(Please consult the nearest General Pneumatics Authorized Service Center for assistance.)

FIELD SERVICE GUIDE

Problems most frequently encountered with refrigerated dryers are water downstream of the dryer and excessive pressure drop. Most causes can be identified and remedied by following this guide.

DANGER

Closed refrigeration systems are potentially dangerous. Work done on the refrigeration system must be done only by a competent refrigeration mechanic.

Do not release fluorocarbon refrigerants to the atmosphere; do not discharge liquid refrigerants into floor drains. All refrigerants must be recovered per EPA requirements.

Do not smoke while working on the refrigeration system or when a refrigeration leak is suspected. Burning materials may decompose refrigerants, forming toxic gas or acids that may cause serious injury and property damage.

Dismantling or working on any component of the compressed air system under pressure may cause equipment failure and serious personal injury. Before dismantling any part of the dryer or compressed air system, completely vent the internal pressure to the atmosphere.

The refrigerant valves are adjusted at the factory with the refrigerant system operating and no air flow through the dryer. While the dryer is operating, the suction pressure/temperature may fluctuate slowly with changes in the refrigeration load. To determine the suction pressure/temperature, a refrigeration mechanic should attach a set of gauges to the unit. Gauge readings should be as follows:

**Table V
SUCTION PRESSURE/TEMPERATURE**

REFRIGERANT	WITHOUT AIR FLOW	WITH AIR FLOW
R-22	58 psig / 33°F	68 psig / 40°F

Do not adjust refrigerant valves without factory authorization. Adjustments must be made only with no air flow into the dryer.

**Table VI
REFRIGERANT PRESSURE CONTROL SETTINGS**

FAN CYCLE CONTROL Pressure Switch Settings (psig)		
MODEL	ON	OFF
TKF200A	275	195
TKF250A		
TKF325A		
TKF400A		
TKF500A		
TKF600A		
TKF800A		
TKF1000A		
Fan 1		
TKF1200A	275	190
TKF1500A		
Fan 2		
TKF1200A	295	255
TKF1500A		

REFRIGERANT COMPRESSOR CONTROL Pressure Switch Setting (psig)		
SENSOR LOCATION	CUT OUT	CUT IN
Compressor Discharge	375	275
Compressor Suction	35	60

FIELD SERVICE GUIDE

Problem	SYMPTOM(S)	POSSIBLE CAUSE	REMEDY
Water downstream of dryer.	No discharge from drain valves.	Drain valve failure or accumulation of dirt in drain valve.	Dismantle drain valve; clean, repair or replace. See Maintenance section.
	Inlet air temperature is outside normal range or reaches alarm set point.	Aftercooler malfunction.	Check aftercooler discharge temperature. Reduce temperature to 120°F max.; reduce airflow if temperature is above 100°F
	Liquid water entering dryer.	Aftercooler drain valve malfunction.	Dismantle aftercooler drain valve; clean, repair or replace.
	Excessive airflow (may also cause high pressure drop).	Dryer improperly sized.	Check airflow and dryer capacity (see Tables VII and VIII). Reduce airflow or resize and replace dryer.
	Refrigerant compressor cut out by high refrigerant discharge pressure control.	1. Condenser fouled or clogged.	1. Clean condenser coils (see Maintenance).
		2. Fan motor stopped.	2. Repair or replace fan motor.
		3. Inlet air temperature too high.	3. Check aftercooler discharge temperature. Reduce temperature to 120°F max.; reduce airflow if temperature is higher than 100°F (see Airflow section).
		4. Air in refrigeration system.	4. Have refrigeration mechanic locate and repair leak. Recharge. Refer to data plate for refrigerant type and quantity.
		5. Ambient air temperature too high for air-cooled compressor.	5. Vent compressor room to outside.
		6. Aftercooler coolant air blowing on air-cooled condenser.	6. Baffle or vent to outside air.
	Compressor cuts out on internal overload.	1. Inadequate ventilation of air-cooled compressor.	1. Ensure adequate ventilation of the condensing unit (see Location and Clearance). Motor will restart automatically when compressor is cool.
		2. Insufficient cooling water for water-cooled compressor.	2. Ensure adequate cooling water. Motor will restart automatically when compressor is cool. Note: Inadequate cooling water may also affect dew point performance.
		3. Leak in refrigeration system.	3. Locate leak. Repair and recharge. Motor will restart automatically when compressor is cool.
		4. Incorrect adjustment of refrigeration control valves.	4. Call your local distributor.
	Compressor windings read open or shorted.	Compressor burned out.	Have refrigeration mechanic check and replace.
	Suction temperature higher than 65°F.	1. Improper adjustment of HGBV.	1. Remove cap from HGBV and screw out HGBV ½ turn with an allen wrench to lower suction pressure to the level listed in Table V. THIS ADJUSTMENT MUST BE MADE WITH NO AIR FLOW THROUGH THE DRYER.
		2. Inlet air temperature higher than 130°F.	2. Reduce aftercooler discharge temperature to design conditions (130°F max.).
		3. Excessive airflow.	3. Check airflow and system capacity. Reduce airflow or resize and replace system.
		4. Leak in refrigeration system.	4. Locate leak; repair and recharge.

FIELD SERVICE GUIDE (Continued)

Problem	SYMPTOM(S)	POSSIBLE CAUSE	REMEDY
Water downstream of dryer (continued).	Refrigerant discharge temperature lower than 140°F.	Low ambient temperature.	Consult your local distributor.
	Refrigerant discharge temperature higher than 250°F.	1. Condenser fouled or clogged.	1. Clean or replace condenser.
		2. Fan motor inoperative.	2. Replace fan motor.
		3. Incorrect fan cycling switch setting.	3. Consult your local distributor.
		4. Inlet air temperature too high.	4. Check temperature of inlet air. Reduce to design conditions.
	5. High ambient temperature.	5. Ventilate area.	
High pressure drop across dryer.	Inlet air temperature lower than 40°F.	Low ambient temperature.	Turn off dryer until ambient temperature exceeds required pressure dew point.
	Excessive airflow (may also cause water downstream of dryer).	Dryer improperly sized.	Check airflow and dryer capacity (see Tables VII and VIII). Reduce airflow or resize and replace dryer.
	Dryer icing up.	Suction temperature lower than 32°F.	Adjust HGBV clockwise to raise the suction pressure to the level listed in Table V. THIS ADJUSTMENT MUST BE MADE WITH NO AIR FLOW THROUGH THE DRYER.
	Intermediate air temperature below 32°F.	Dryer icing up.	1. Adjust operating conditions to meet sizing conditions. 2. Adjust HGBV to raise suction pressure to the level listed in Table V. THIS ADJUSTMENT MUST BE MADE WITH NO AIR FLOW THROUGH THE DRYER.
High suction temperature.	Intermediate air temperature too high. Frosting of compressor or no cooling. Refrigerant suction temperature too high.	1. Loss of refrigerant charge. Refrigerant compressor cycles on low pressure control.	1. Locate leak. Repair and recharge.
		2. Refrigerant filter/dryer plugged up.	2. Replace filter/dryer.
	Refrigerant discharge temperature higher than 220°F. Refrigerant suction temperature higher than 65°F.	Water in refrigeration system. Leak in chiller or water-cooled condenser.	Locate leak. Repair leak or replace chiller or condenser.
Intermediate air temperature too high.	High suction temperature.	1. Loss of refrigerant charge. Refrigerant compressor cycles on low pressure control.	1. Locate leak. Repair and recharge.
		2. Refrigerant filter/dryer plugged up.	2. Replace filter/dryer.
No condensate from automatic drain valve (ADV).	Valve continuously venting.	1. Clogged diaphragm.	1. Clean diaphragm.
		2. Short in electrical component.	2. Check and replace connector or timer assembly.

FIELD SERVICE GUIDE (Continued)

Problem	SYMPTOM(S)	POSSIBLE CAUSE	REMEDY
No discharge from drain	Valve not cycling.	1. No electrical power.	1. Check and replace connector or timer assembly.
		2. Timer malfunction.	2. Replace timer assembly.
		3. Solenoid coil malfunction.	3. Replace solenoid coil.
		4. Clogged ports.	4. Clean ports.
	No response when test button is pushed.	1. No electrical power.	1. Check and correct power supply and connections.
		2. Timer malfunction.	2. Replace timer assembly.
RS-232 Communication does not work	Remote communication does not work	1. JP4 (1½ inches above the RS-232 connector) is configured incorrectly	1. For RS-232 output, pins 1 & 2 should be jumped. For fiber communication (DET4), pins 3 & 4 should be jumped.
		2. Loose connections	2. Make sure connectors are completely pushed in.
		3. Incorrect wire for length of run	3. RS-232 is only suitable for wire runs under 30 feet. Use RS-485 for wire runs 30 to 4,000 feet.
		4. Incorrect configuration	4. Wiring must be configured to correspond with the logic board's data communication ports.

TROUBLESHOOTING

Troubleshooting Guide

Problem	Possible Cause	Remedy							
LCD Screen is blank and not lit	No electrical power	1. On the logic board, the green power on indicator (L1) should be on.							
		2. Check fuse F1. If the fuse is blown, the red LED (L23) located next to the fuse will be lit.							
		3. Verify power supply and connections. Fuse F1 will blow if the 12 Volt supply is wired with reversed polarity.							
		4. Verify high voltage board has power. <ul style="list-style-type: none"> • P10 on the logic board should have 12 Volts coming in from the high voltage board. Pin 1 is positive 12 Volt red wire, pin 2 is negative black wire. • The green LED (L1) on the high voltage board should be lit. 							
		5. Check for blown fuse. Three neon lamps on the board light when a fuse blows: <table border="0" style="margin-left: 20px;"> <tr> <td>LP1</td> <td>Fuse F1</td> <td>L1 115 Volts</td> </tr> <tr> <td>LP2</td> <td>Fuse F2</td> <td>Neutral 115 Volts</td> </tr> <tr> <td>LP3</td> <td>Fuse F3</td> <td>Fuse for all of the 115 Volt outputs of P3 and P4</td> </tr> </table>	LP1	Fuse F1	L1 115 Volts	LP2	Fuse F2	Neutral 115 Volts	LP3
LP1	Fuse F1	L1 115 Volts							
LP2	Fuse F2	Neutral 115 Volts							
LP3	Fuse F3	Fuse for all of the 115 Volt outputs of P3 and P4							
Thermocouple Failure The red LED L2 located on the upper left side of the high voltage board is blinking.	Temperature out of range	1. Push F1(MODE) key on the controller keypad to view the temperature screens. 2. Scroll through the temperature screens using the F2(PAGE) key looking for a temperature reading that is out of bounds, such as 999°F.							
	Loose thermocouple connection	Verify the plug is firmly in the socket and the wires are secure within the plug. The holding screw should be against the wire and not the insulation of the wire.							
	Faulty thermocouple	If the L2 is still blinking after checking 1 thru 3 above, pull out the thermocouple plug and short the two pins in the socket. If L2 turns off, the thermocouple is faulty. If L2 stays lit, there is a logic board problem							
Compressor will not start	One minute delay	There is a standard one minute delay before the compressor will start after being shut down. The display screen will say "normal operation." If there are no problems, the compressor will energize once the minute has passed.							
	Crankcase heater temperature below suction temp.	If the crankcase heater temperature is below the refrigerant suction saturation temperature, the compressor will not start. The screen will display "Pending start, warm up." The compressor will start once the crankcase temperature is 4°F above the suction temperature.							
	Pressure is out of range or faulty pressure switch	1. On the high voltage board, verify fiber optic emitters A and B are on.							
		2. If fiber optic emitter A on the high voltage board is not on (yellow LED), there is excessive discharge pressure or the discharge pressure switch has failed.							
		3. If fiber optic emitter B on the high voltage board is not on (blue LED), the suction pressure is too low or the suction pressure switch has failed.							
Bad connection	4. If the pressure package is enabled, verify the pressures by pressing F1(MODE) to display the pressure screens. Press F2(PAGE) to view screen 2 of 2.								
	1. Verify L2 (red LED) on the high voltage board is on. If not, this indicates the compressor is not receiving the "on" signal from E1 on the logic board over the fiber cable.								
	2. Check P1 on connectors P3 and P4 for 115 Volt output. Test with a device that has a load, such as an incandescent light or a solenoid.								
		3. If L2 (red LED) is on, and P3 & P4 have 115 Volts, verify contactor is closed.							

Troubleshooting Guide

Problem	Possible Cause	Remedy
Drain Solenoid will not work	Logic board problem	When the drain valve is time activated and fiber optic emitter E2 on the logic board does not turn on, there is a problem with the board.
	Faulty device	If a demand drain system is used, such as a float or capacitance sensor, and fiber optic emitter E2 does not turn on, check the device for proper operation.
	Drain delay	There is a standard initial 30 second delay between each drain energized when 2 or 3 drains are used.
	Bad connection or cable	If E2 does turn on and the solenoid is not energized, check the following: <ul style="list-style-type: none"> • Check fiber optic cable #1 for light. • Verify L3 (red LED) on high voltage board is lit. • Check the high voltage output on P3 and P4 at pins 2 (DO NOT USE VOLTMETER). • Check the solenoid coil for continuity.
Alarm relay does not energize	Faulty device or connection	1. Verify red LED L4 is off. If there is no active alarm, fiber optic emitter E3 turns on and transmits light down fiber optic cable #3 to detector FO3 on the high voltage board.
		2. Verify pins 3 on connectors P3 and P4 on the high voltage board have 115 Volts. If there is 115 Volts, then the alarm relay is faulty
RS-232 communication does not work	Configured incorrectly	1. Verify the RS-232 connections of P22: <ul style="list-style-type: none"> • Pin 3 is the data signal out to a remote receiver • Pin 5 is data into the logic board from a remote transmitter • Pin 7 is ground
		2. Locate connector J4 (1½ inches above the RS-232 connector). <ul style="list-style-type: none"> • For RS-232 output, the jumper should be on pins 1 and 2. • For fiber communications, the jumper should be on pins 2 and 3.
		3. Verify the connectors are completely pushed in.
		4. Verify wiring is configured to correspond with the logic board's data communication ports.
Fan will not run	Faulty device	1. Verify compressor contactor is energized.
		2. Check fan pressure switch.
		3. Check fan capacitor (if used).
		4. Check fan motor.

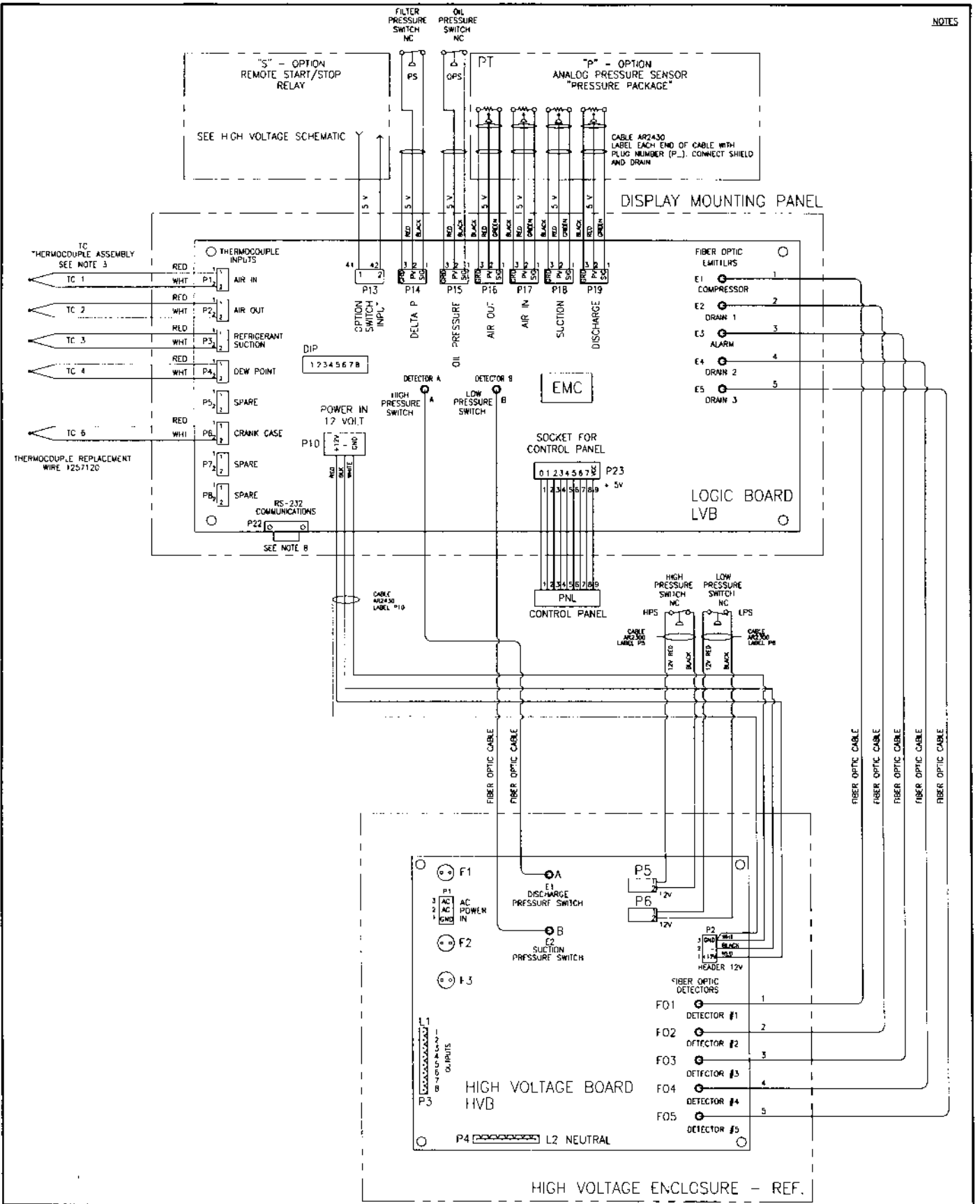

Electrical Schematic - Electronic Synoptic Controller

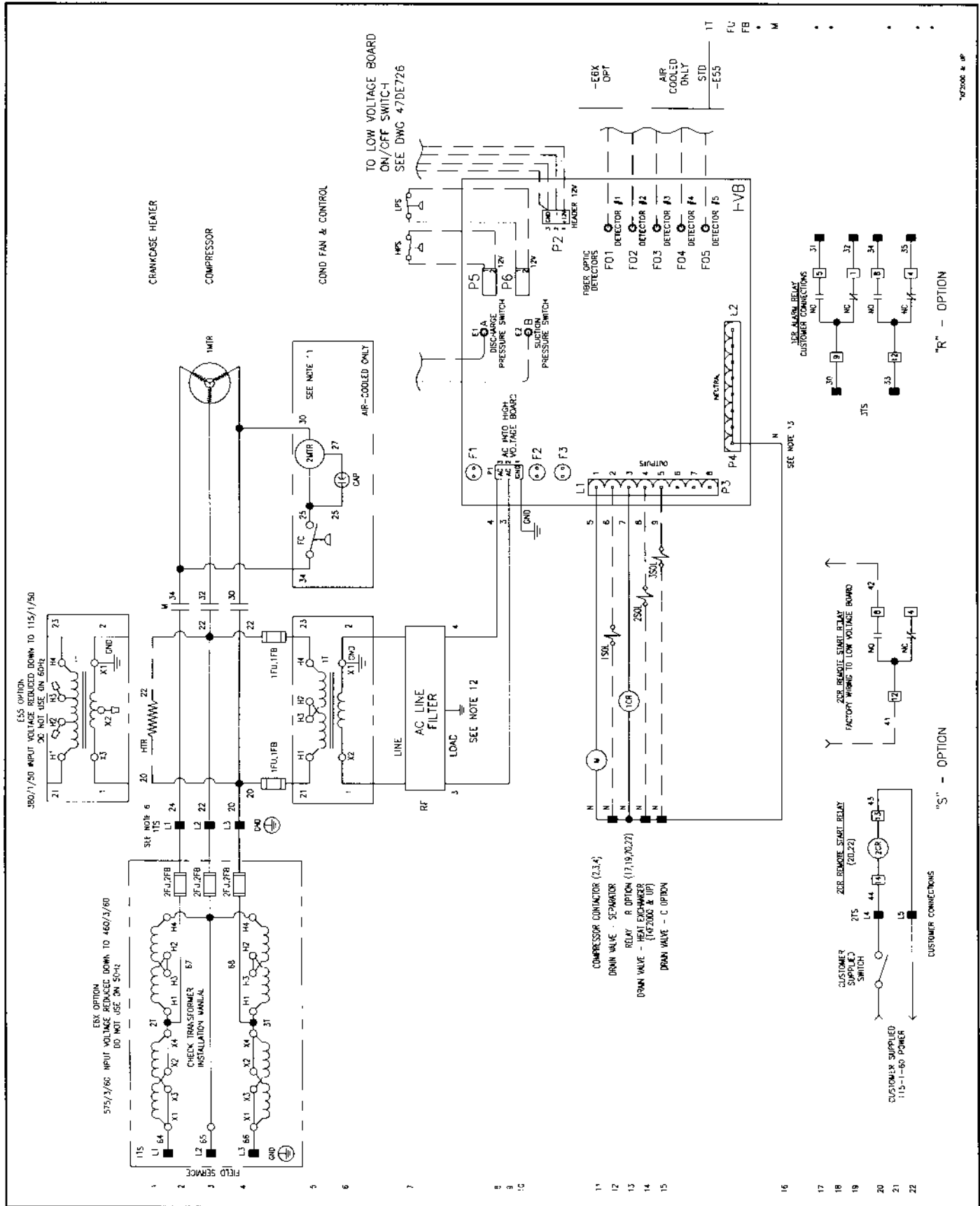

Electrical Schematic - TKF250 thru TKF1500

Table VII
AIR-COOLED DRYER SPECIFICATIONS

MODEL	FLOW CAPACITY (scfm)	MAXIMUM WORK PRESSURE (psig)	REFRIGERANT		VOLTAGE (V/Ø/Hz)	INPUT POWER (kW)	FULL LOAD AMPS	MAXIMUM HEAT REJECTION (Btu/hr)	MAXIMUM PRESSURE DROP (psig)	AIR INLET AND AIR OUTLET CONNECTION (inches NPT) ³	SEPARATOR DRAIN CONNECTION (inches NPT)	UNIT WEIGHT LBS (KG)
			Type ²	Unit hp								
TKF200A	200	250	R-22	1	208-230/1/60* 460/3/60 575/3/60	2.0 3.9	8.7 4.9	12,125	5.0	1½	¼	366 (166)
TKF250A	250	250	R-22	1½	208-230/1/60 208-230/3/60 460/3/60* 575/3/60	2.7 3.5 3.1	11.6 8.8 3.9	15,156	5.0	1½	¼	431 (196)
TKF325A	325	250	R-22	1½	208-230/1/60 208-230/3/60 460/3/60* 575/3/60	2.7 3.5 3.1	11.6 8.8 3.9	19,703	5.0	1½	¼	448 (203)
TKF400A	400	250	R-22	2	208-230/3/60 460/3/60* 575/3/60	4.3 4.1 5.3	10.8 5.2 5.4	24,250	5.0	1½	¼	675 (306)
TKF500A	500	250	R-22	3	208-230/3/60 460/3/60* 575/3/60	4.8 4.6 5.9	12.1 5.8 5.9	30,313	5.0	2½	¼	750 (340)
TKF600A	600	250	R-22	3	208-230/3/60 460/3/60* 575/3/60	4.8 4.6 5.9	12.1 5.8 5.9	36,375	5.0	2½	¼	775 (352)
TKF800A	800	250	R-22	4	208-230/3/60 460/3/60* 575/3/60	5.2 7.1 9.4	13.0 9.0 9.5	48,500	5.0	3	¼	850 (386)
TKF1000A	1,000	250	R-22	5	208-230/3/60 460/3/60* 575/3/60	9.2 9.0 11.9	23.2 11.3 11.9	60,625	5.0	3	¼	1,050 (477)
TKF1200A	1,200	250	R-22	5	460/3/60* 575/3/60	9.0 11.8	11.3 11.8	72,750	5.0	3	¼	1,310 (594)
TKF1500A	1,500	250	R-22	7	460/3/60* 575/3/60	10.2 13.4	12.8 13.4	90,938	7.5	3	¼	1,370 (621)

¹ Rating conditions, in accordance with Recommended Standard NFPA/T3.27.2-1981 (ANSI B93.45M) and CAGI Standard No. ADF-100 for 33°F -39°F pressure dew point, are 100°F inlet temperature, 100% inlet relative humidity, 100°F ambient temperature and 5 psi maximum pressure drop.

² Refer to the dryer data plate for the refrigerant charge.

³ Compression fitting to be customer supplied.

* Denotes standard voltage.

Table VIII
WATER-COOLED DRYER SPECIFICATIONS

MODEL	FLOW CAPACITY (scfm) ¹	MAXIMUM WORK PRESSURE (psig)	REFRIGERANT		VOLTAGE (V/Ø/Hz)	INPUT POWER (kW)	FULL LOAD AMPS	MAXIMUM HEAT REJECTION (BTU/hr)	MAXIMUM PRESSURE DROP (psig)	INLET/OUTLET CONNECTION (inches NPT)			SEPARATOR DRAIN CONNECTION (inches NPT)	UNIT WEIGHT LBS (KG)
			Type ²	Unit hp						AIR IN	AIR OUT	WATER IN		
TKF200W	200	250	R-22	1	208-230/1/60*	1.4	6.1	12,125	5.0	1 1/2	1 1/2	3/8	1/4	366 (166)
					460/3/60	3.4	4.3							
					575/3/60									
TKF250W	250	250	R-22	1 1/2	208-230/1/60	2.1	9.0	15,156	5.0	1 1/2	1 1/2	3/8	1/4	431 (196)
					208-230/3/60	2.5	6.2							
					460/3/60*	2.6	3.3							
TKF325W	325	250	R-22	1 1/2	208-230/1/60	1.9	9.9	19,703	5.0	1 1/2	1 1/2	3/8	1/4	448 (203)
					208-230/3/60	2.1	6.2							
					460/3/60*	2.6	3.3							
TKF400W	400	250	R-22	2	208-230/3/60	3.5	8.8	24,250	5.0	1 1/2	1 1/2	3/8	1/4	675 (306)
					460/3/60*	3.3	4.2							
					575/3/60	4.3	4.2							
TKF500W	500	250	R-22	3	208-230/3/60	4.0	10.1	30,313	5.0	2 1/4	2 1/2	1/2	1/4	750 (340)
					460/3/60*	3.8	5.0							
					575/3/60	4.9	4.9							
TKF600W	600	250	R-22	3	208-230/3/60	4.0	10.1	36,375	5.0	2 1/2	2 1/2	1/2	1/4	775 (352)
					460/3/60*	3.8	5.0							
					575/3/60	4.9	4.9							
TKF800W	800	250	R-22	3 1/2	208-230/3/60	4.1	10.2	48,500	5.0	3	3	1/2	1/4	850 (386)
					460/3/60*	6.0	8.1							
					575/3/60	7.8	9.9							
TKF1000W	1,000	250	R-22	4 1/2	208-230/3/60	8.1	20.4	60,625	5.0	3	3	1/2	1/4	1,050 (477)
					460/3/60*	7.8	9.9							
					575/3/60	10.5	10.5							
TKF1200W	1,200	250	R-22	5	460/3/60*	7.3	9.1	72,750	5.0	3	3	1	1/4	1,283 (582)
					575/3/60	9.6	9.6							
					460/3/60*	8.5	10.6							
TKF1500W	1,500	250	R-22	7	460/3/60*	8.5	10.6	90,938	7.5	3	3	1	1/4	1,312 (595)
					575/3/60	11.2	11.2							
					460/3/60*	11.2	11.2							

¹ Rating conditions, in accordance with Recommended Standard NFPA/T3.27.2-1981 (ANSI B93.45M) and CAGI Standard No. ADF 100 for 33°F - 39°F pressure dew point, are 100°F inlet temperature, 100% inlet relative humidity, 100°F ambient temperature and 5 psi maximum pressure drop.

² Refer to dryer data plate for refrigerant charge.

* Indicates standard voltage.

TKF200A - TKF400A FLOW SCHEMATIC

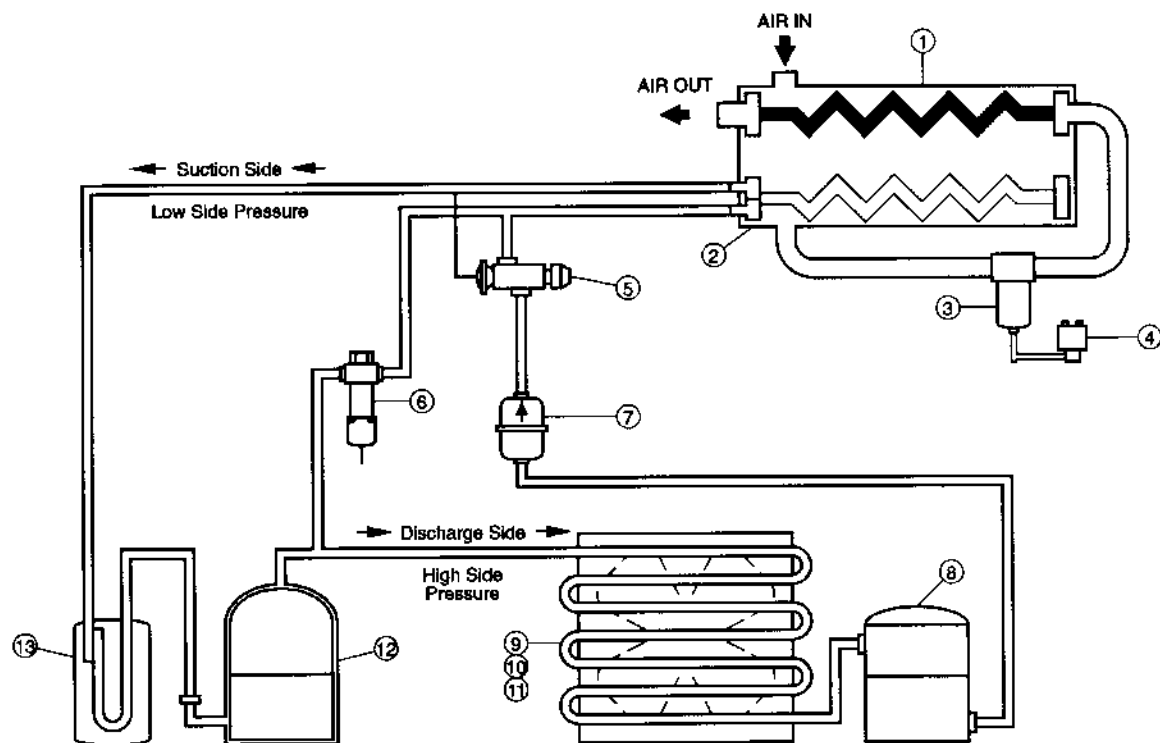

TKF200A - TKF400A REPLACEMENT PARTS*

No.	Description	TKF200A	TKF250A	TKF325A	TKF400A
1-2	Air to Air Heat Exchanger/Evaporator	7DE127QK	7DE127QL	7DE127QM	7DE127QN
3	Separator	7DE220FM	7DE220FM	7DE220FQ	7DE220FQ
4	Drain Valve	7DE345NP	1247890	1247890	1247890
5	Thermal Expansion Valve	7DE305ED	7DE305ED	7DE305ED	7DE305ET
6	Hot Gas Bypass Valve	7DE315AE	7DE315AE	7DE315AE	7DE315AF
7	Refrigerant Filter/Dryer	7DE30AP	7DE30AP	7DE30AP	7DE30AP
8	Receiver Tank	7DE50NV	7DE50NV	7DE50NV	7DE50NW
9	Condenser	42DE5044A	42DE5044A	42DE5044A	42DE5122A
10	Fan Motor	7DE41VD	7DE41CZ	7DE41CZ	7DE41VN
11	Fan Blade	7DE41VG	7DE41VG	7DE41VG	7DE41VP
12	Compressor	7DE40HB	7DE40LT	7DE40LT	7DE40HD
13	Refrigerant Accumulator	N/A	N/A	N/A	7DE5S
	Fan Cycle Switch	7DE60EN	7DE60EN	7DE60EN	7DE60EP
	High Pressure Cutout	7DE60DK	7DE60DK	7DE60DK	7DE60DK
	Electronic Synoptic Controller	Consult Factory			
	Fuse F1, F2 (High Voltage Board)	1259189	1259189	1259189	1259189
	Fuse F3 (High Voltage Board)	1236719	1236719	1236719	1236719
	Fuse F1 (Low Voltage Board)	1242350	1242350	1242350	1242350

* Replacement parts shown are for standard voltage only.

TKF500A - TKF1000A FLOW SCHEMATIC

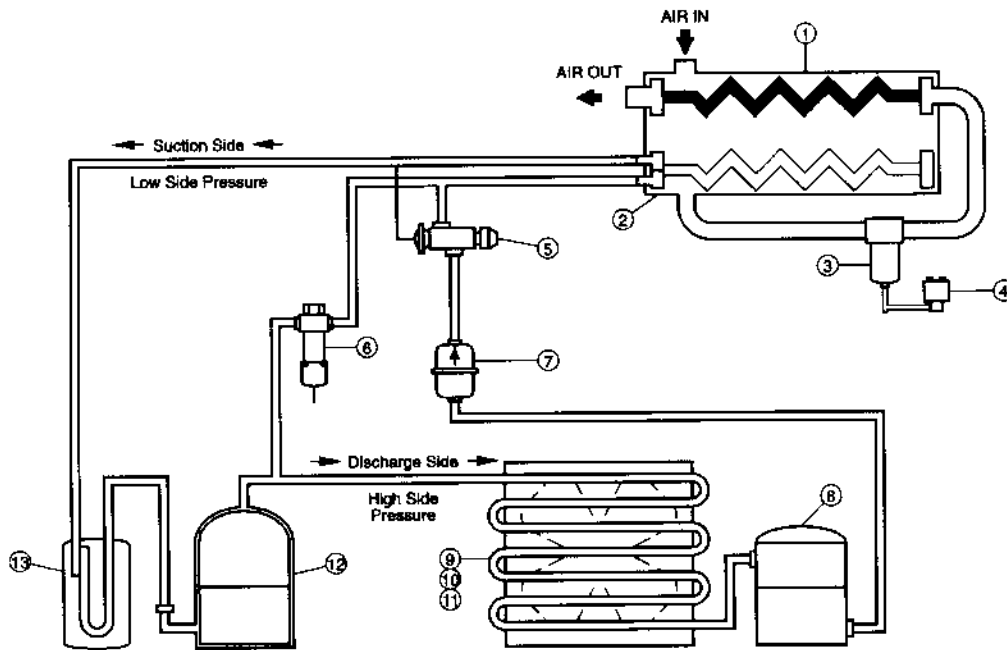

TKF500A - TKF1000A REPLACEMENT PARTS*

NO.	DESCRIPTION	TKF500A	TKF600A	TKF800A	TKF1000A
1-2	Air to Air Heat Exchanger/Evaporator	7DE127QP	7DE127QQ	7DE127QR	7DE127QS
3	Separator	1266442	1266442	1266442	1266442
4	Drain Valve	1247890	1247890	1247890	1247890
5	Thermal Expansion Valve	7DE305BW	7DE305BW	7DE305EE	7DE305EE
6	Hot Gas Bypass Valve	7DE315AF	7DE315AF	7DE315AF	7DE315AF
7	Refrigerant Filter/Dryer	7DE30AP	7DE30AP	7DE30AQ	7DE30AQ
8	Receiver Tank	7DE50NW	7DE50NW	7DE50NX	7DE50NX
9	Condenser	42DE5125A	42DE5125A	42DE5127A	42DE5127A
10	Fan Motor	7DE41VN	7DE41VN	7DE41VR	7DE41VR
11	Fan Blade	7DE41VP	7DE41VP	7DE41VQ	7DE41VQ
12	Compressor	7DE40KF	7DE40KF	7DE40HF	7DE40LQ
13	Refrigerant Accumulator	7DE5S	7DE5S	7DE5S	7DE5X
	Fan Cycle Switch	7DE60EP	7DE60EP	7DE60EP	7DE60EP
	High Pressure Cutout	7DE60DK	7DE60DK	7DE60DK	7DE60DK
	Electronic Synoptic Controller	Consult Factory			
	Fuse, Low Voltage Board; F1	1242350	1242350	1242350	1242350
	Fuse, High Voltage Board; F1, F2	1259189	1259189	1259189	1259189
	Fuse, High Voltage Board; F3	1236719	1236719	1236719	1236719

* Replacement parts are listed at standard voltage. For optional voltages, consult distributor.

TKF1200A - TKF1500A FLOW SCHEMATIC

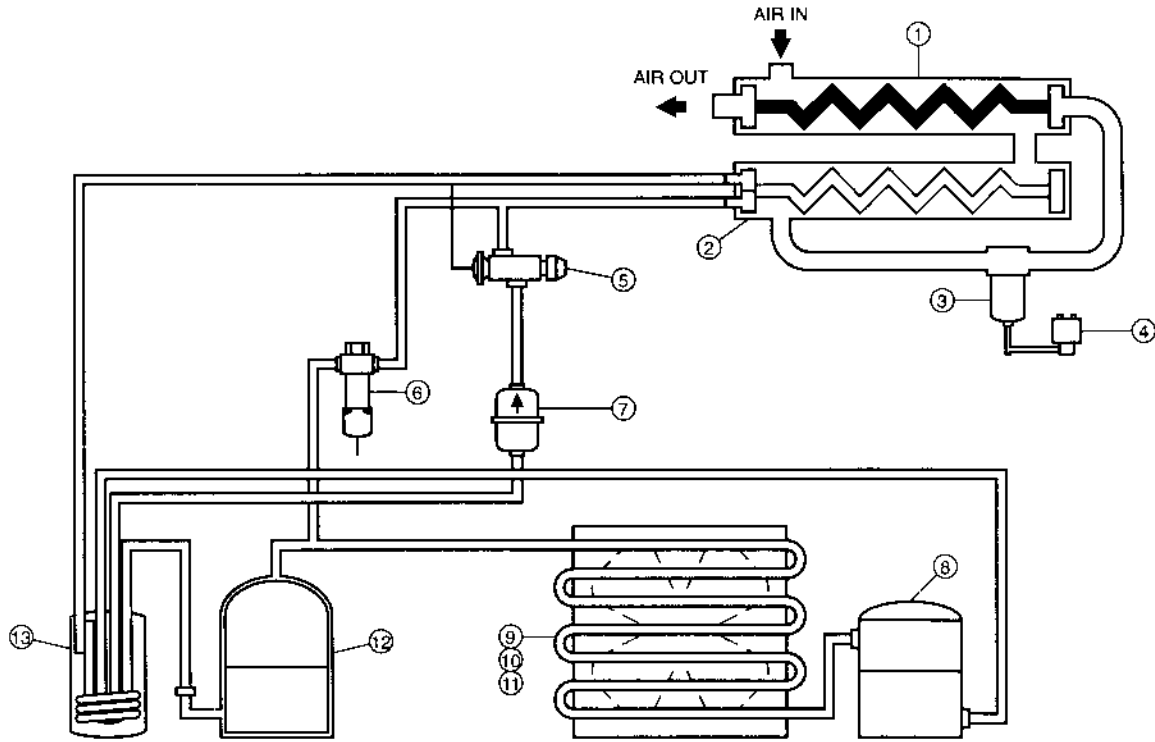

TKF1200A - TKF1500A REPLACEMENT PARTS*

NO.	DESCRIPTION	TKF1200A	TKF1500A
1	Air to Air Heat Exchanger Assembly	1242550	1242550
2	Evaporator	1242506	1242506
3	Separator	1266442	1266442
4	Drain Valve	1247890	1247890
5	Thermal Expansion Valve	1226569	1226569
6	Hot Gas Bypass Valve	1227318	1227318
7	Refrigerant Filter/Dryer	1226969	1226969
8	Receiver Tank	1226479	1226479
9	Condenser	1242345	1242345
10	Fan Motor	1229496	1229496
11	Fan Blade	1228135	1228133
12	Compressor	1243958	1227192
13	Refrigerant Accumulator	1226555	1226555
	Fan Cycle Switch	1227310	1227310
	High Pressure Cutout	1227312	1227312
	Electronic Synoptic Controller	Consult Factory	
	Fuse, Low Voltage Board; F1	1242350	1242350
	Fuse, High Voltage Board; F1, F2	1259189	1259189
	Fuse, High Voltage Board; F3	1236719	1236719

* Replacement parts are listed at standard voltage. For optional voltages, consult distributor.

TKF200W - TKF400W FLOW SCHEMATIC

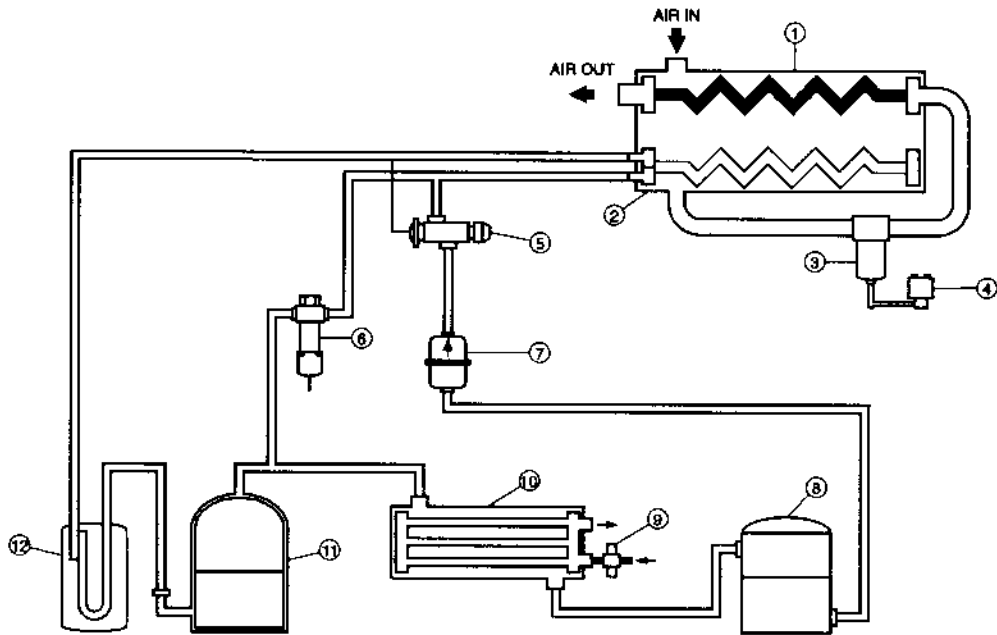

TKF200W - TKF400W REPLACEMENT PARTS*

No.	Description	TKF200W	TKF250W	TKF325W	TKF400W	TKF500W	TKF600W
1	Air to Air Heat Exchanger/Evaporator	7DE127QK	7DE127QL	7DE127QM	7DE127QN	7DE127QP	7DE127QQ
3	Separator	7DE220FQ	7DE220FQ	7DE220FQ	7DE220FQ	1266442	1266442
4	Drain Valve	7DE345NP	7DE345NL	1247890	1247890	1247890	1247890
5	Thermal Expansion Valve	7DE305ED	7DE305ED	7DE305ED	7DE305ET	7DE305BW	7DE305BW
6	Hot Gas Bypass Valve	7DE315AE	7DE315AE	7DE315AE	7DE315AF	7DE315AF	7DE315AF
7	Refrigerant Filter/Dryer	7DE30AP	7DE30AP	7DE30AP	7DE30AP	7DE30AP	7DE30AP
8	Receiver Tank	7DE50NV	7DE50NV	7DE50NV	7DE50NW	7DE50NW	7DE50NW
9	Water Regulating Valve	31DE138A	31DE138A	31DE138A	31DE138A	31DE138A	31DE138A
10	Condenser	7DE50NS	7DE50NT	7DE50NT	7DE50MZ	7DE50NA	7DE50NA
11	Compressor	7DE40HB	7DE40LT	7DE40LT	7DE40HD	7DE40KF	7DE40KF
12	Refrigerant accumulator	N/A	N/A	N/A	7DE5S	7DE5S	7DE5S
	Electronic Synoptic Controller	Consult Factory					
	Fuse F1, F2 (High Voltage Board)	1259189	1259189	1259189	1259189	1259189	1259189
	Fuse F3 (High Voltage Board)	1236719	1236719	1236719	1236719	1236719	1236719
	Fuse F1 (Low Voltage Board)	1242350	1242350	1242350	1242350	1242350	1242350

* Replacement parts shown are for standard voltage only.

TKF500W - TKF1000W FLOW SCHEMATIC

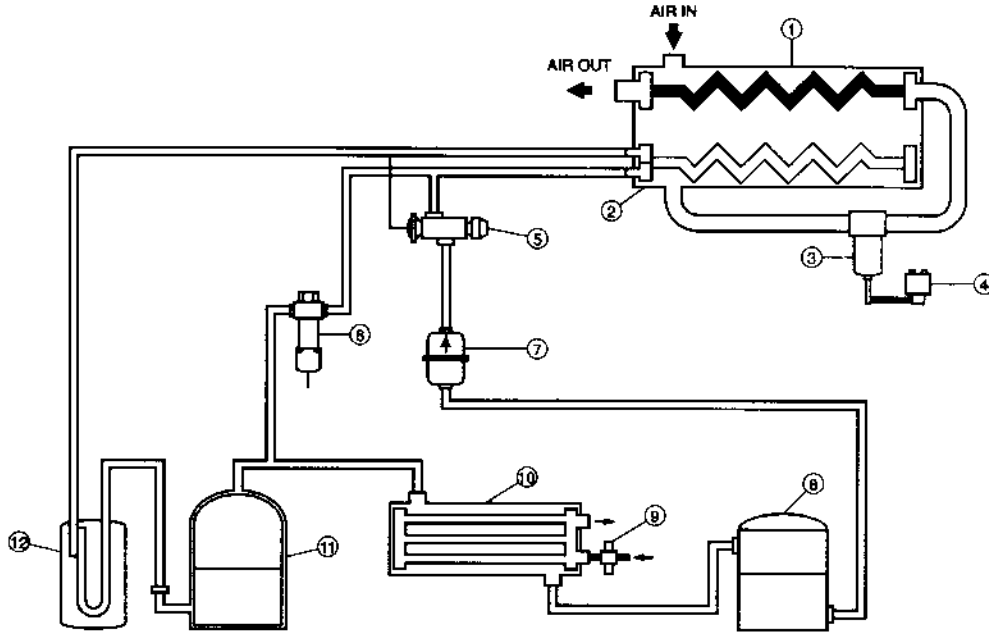

TKF500W - TKF1000W REPLACEMENT PARTS*

NO.	DESCRIPTION	TKF500W	TKF600W	TKF800W	TKF1000W
1-2	Air to Air Heat Exchanger/Evaporator	7DE127QP	7DE127QQ	7DE127QR	7DE127QS
3	Separator	1266442	1266442	1266442	1266442
4	Drain Valve	1247890	1247890	1247890	1247890
5	Thermal Expansion Valve	7DE305BW	7DE305BW	7DE305EE	7DE305EE
6	Hot Gas Bypass Valve	7DE315AF	7DE315AF	7DE315AF	7DE315AF
7	Refrigerant Filter/Dryer	7DE30AP	7DE30AP	7DE30AQ	7DE30AQ
8	Receiver Tank	7DE50NW	7DE50NW	7DE50NX	7DE50NX
9	Water Regulating Valve	31DE138A	31DE138A	31DE138B	31DE138B
10	Condenser	7DE50NA	7DE50NA	7DE50MK	7DE50MV
11	Compressor	7DE40KF	7DE40KF	7DE40HF	7DE40LR
12	Refrigerant Accumulator	7DE5S	7DE5S	7DE5S	7DE5X
	Electronic Synoptic Controller	Consult Factory			
	Fuse, Low Voltage Board; F1	1242350	1242350	1242350	1242350
	Fuse, High Voltage Board; F1, F2	1259189	1259189	1259189	1259189
	Fuse, High Voltage Board; F3	1236719	1236719	1236719	1236719

* Replacement parts are listed at standard voltage. For optional voltages, consult distributor.

TKF1200W - TKF1500W FLOW SCHEMATIC

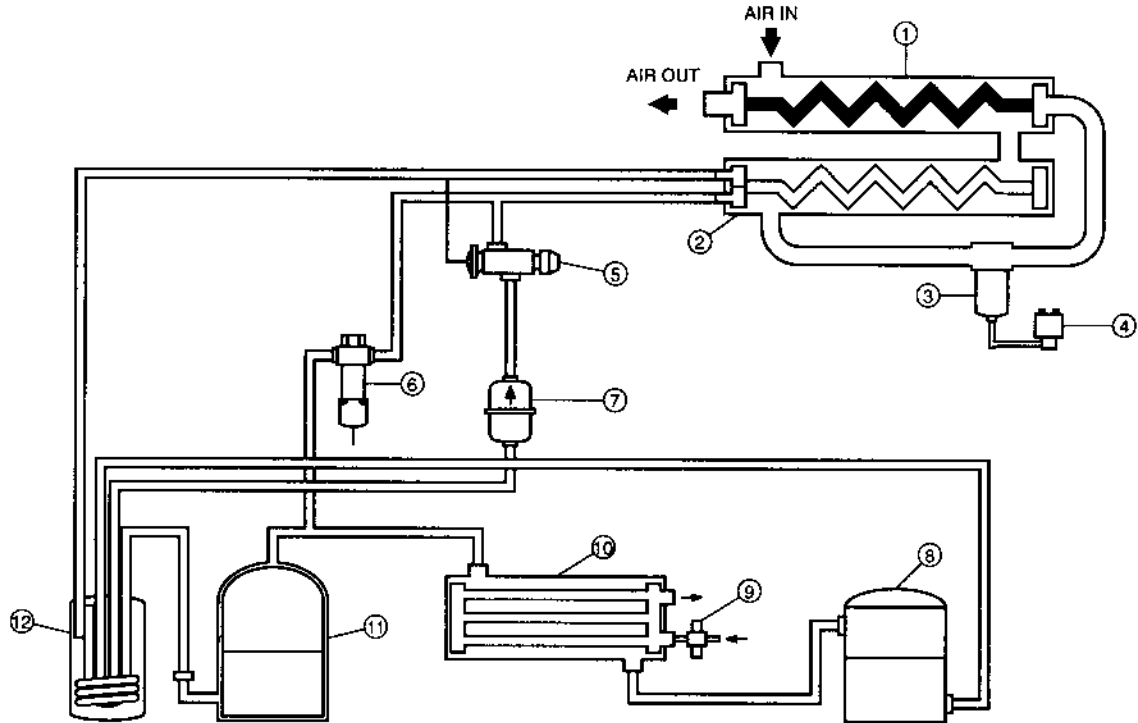

TKF1200W - TKF1500W REPLACEMENT PARTS*

NO.	DESCRIPTION	TKF1200W	TKF1500W
1	Air to Air Heat Exchanger Assembly	1242550	1242550
2	Evaporator	1242506	1242506
3	Separator	1266442	1266442
4	Drain Valve	1247890	1247890
5	Thermal Expansion Valve	1226569	1226569
6	Hot Gas Bypass Valve	1227318	1227318
7	Refrigerant Filter/Dryer	1226968	1226969
8	Receiver Tank	1226479	1226479
9	Water Regulating Valve	1227308	1227307
10	Condenser	1226585	1266441
11	Compressor	1243958	1227192
12	Refrigerant Accumulator	1226555	1226555
	Electronic Synoptic Controller	Consult Factory	
	Fuse, Low Voltage Board; F1	1242350	1242350
	Fuse, High Voltage Board; F1, F2	1259189	1259189
	Fuse, High Voltage Board; F3	1236719	1236719

* Replacement parts are listed at standard voltage. For optional voltages, consult distributor.



General Pneumatics

A United Dominion Company

Flair Industrial Air

4647 SW 40th Avenue • Ocala, FL 34474-5799
Telephone 352-237-4145 • Fax 352-237-2943

U.S. FACILITIES

New Castle, Delaware
Ocala, Florida
Stanley, North Carolina
Kenbridge, Virginia
Rich Creek, Virginia

CANADIAN FACILITIES

Brockville, Ontario
Blainville, Québec
Tel. 800-893-5247 • Fax 800-318-0952

EUROPEAN FACILITIES

Horndean Hants, England
Dortmund, Germany
Killarney, Ireland
Etten-Leur, The Netherlands

ASIAN FACILITIES

Toyko, Japan
Pusan, Korea