

Installation & Operation Manual

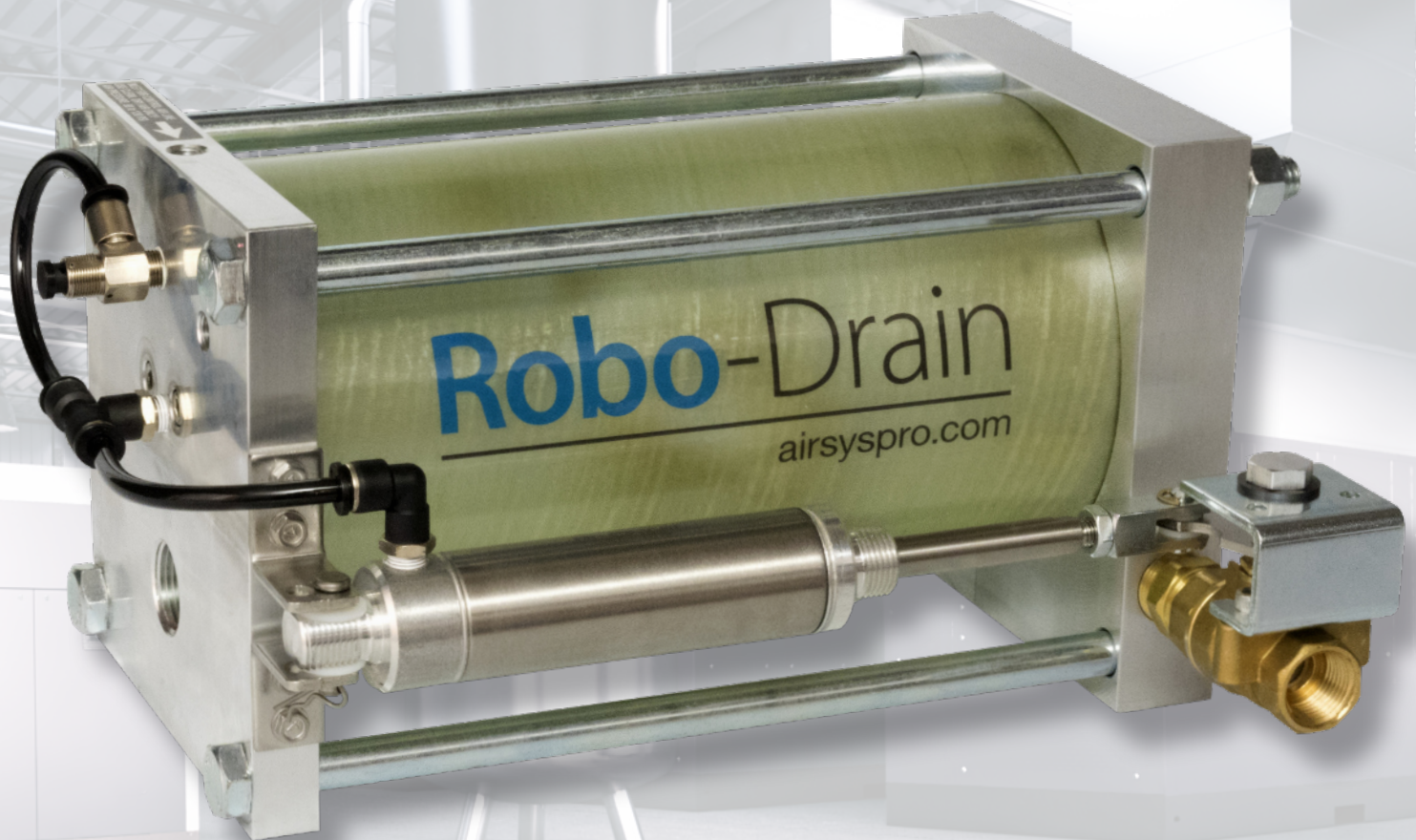

TABLE OF CONTENTS

GENERAL INFORMATION	3
SAFETY	3
WARRANTY	3
INSTALLATION	4
PRODUCT INFORMATION	
INSTALLATION	4
POST-INSTALLATION CHECK.....	4
TROUBLESHOOTING.....	4
OPTIONS.....	4
INSTALLATION CONSIDERATIONS	5
RECEIVER.....	5
FILTER AND AFTERCOOLER SEPARATOR	5
REFRIGERATED DRYER	5
INTERCOOLERS	5
BALANCE LINE	5
GENERAL SPECIFICATIONS	6
DIMENSIONAL DRAWING	7
EXPLODED PARTS DRAWING	8
PARTS LIST	9
MAINTENANCE	9

GENERAL INFORMATION

SAFETY

Locate, read, understand and follow all Danger, Warning, Caution, and Operating Instructions on the product and in all Manuals. Failure to comply with safety precautions described in the manuals supplied with the product this manual or any of the labels and tags attached to the product may result in death, serious injury or property damage.

Check that all labels, tags and data (name) plates are in place and legible. It is your responsibility to ensure this information available to others.

If you have any questions about safety or procedures not included in this manual, ask your distributor or contact Air System Products, LLC.

GENERAL DESCRIPTION

For the condensate to properly enter the Robo-Drain reservoir, the condensate line to the Robo-Drain must always be installed below the source to be drained. It is equally important to provide a means, such as a balance line, for the air in the reservoir to be displaced as condensate enters the drain. If the air cannot be displaced, the condensate will not enter the reservoir. Please review the following suggestions that might best fit your installation. The use of unions and shut-off valves are recommended for both the condensate line and the balance line.

WARRANTY

The Robo-Drain is warranted to be free from defects in workmanship and materials for a period of two years from the date of shipment. The liability of the manufacturer is limited to repair or replacement of the drain at its option. In no event shall the manufacturer be liable for special or consequential damages or for delay in performances of this warranty.

The Robo-Drain is designed for trouble-free operation. When installed and operated properly, the Robo-Drain will provide years of reliable service collecting and discharging condensate, along with pipe scale and other contaminants typically found in a compressed air system.

INSTALLATION



Before installing the drain, ensure the source vessel is isolated from the interconnecting piping to the drain.

Confirm the air system pressure will not exceed the 250 PSI (17 bar) rating of the drain and the inlet temperature should not exceed 180 °F (82 °C).

Connecting drain should be done by using one of the recommended installation diagrams shown on following page. The installation of a pre-strainer is not required or recommended.

Install the drain on a level surface and as close to the source to be drained as possible. Since the Robo-Drain uses gravity to fill the reservoir, the entire drain must be installed below the source when using the top inlet. It isn't recommended that flexible tubing be used on the discharge to prevent it from whipping causing damage or injury.

If the drain is to be installed where the temperatures can fall below 32°F (0 °C), special precautions are needed, including but not limited to heat tracing pipelines and the optional immersion heater.

The Robo-Drain will accept condensate from either the upper or the lower inlet connections. The upper inlet connection is preferred. The inlet port not used must be plugged by using a standard plug.

A balance line is highly recommended to avoid an air-lock condition. The balance line should be connected to the source device to prevent a flow path for system air or condensate.

The drain has a 1/8" NPT vent connection to permit easy installation of a balance line. Use a non-galling pipe sealant on all joints.

The use of isolation valves and bypass piping will permit quick and easy routine maintenance.

The Robo-Drain uses compressed air to drive (control) a drain cycle. **ONLY CLEAN DRY AIR MUST BE USED!** The required control air pressure for the standard models, irrespective of system pressure is 60-130 PSIG (4.1-9.0 barg) Any of the Robo-Drain models can be supplied as an LP variant and will model should be between 40 and 130 PSIG (2.8 and 9.0 barg). The Robo-Drain is supplied with a filter for installation on the control head. The use of unfiltered air can result in failure and can void the product warranty.

Once installed and control air supplied, the drain is ready to be placed in service.

CHECKING THE OPERATION

After installation is complete and the drain is in service, a check should be made that the drain is functioning properly.

1. Ensure that condensate is properly entering the reservoir. This can be easily done looking through the translucent reservoir
2. Press the test button to ensure the drain valve opens and closes when the button is released.
3. Inspect for any air or condensate leaks. Correct as necessary.

TROUBLESHOOTING

If condensation is not entering the reservoir, check for the following:

1. Check that any valves between the source and drain are open.
2. Check that the balance line is open and properly installed. Alternatively, that the vent valve is cracked open.

If the drain is not emptying:

1. Press the test button to force a manual drain cycle. If the air actuator does not open the valve, check that the control air supply is at least the minimum pressure required.
2. If the valve opens, but the drain does not empty quickly, no more than 20 seconds, ensure that there is system pressure.
3. If still not emptying, check the downstream piping from the drain valve to ensure there isn't a closed valve or an obstruction.
4. If the drain is still not draining, suggest contacting the factory.

OPTIONS

High Level Alarm
Mechanical Cycle Counter
Digital Cycle Counter

INSTALLATION CONSIDERATIONS

For the condensate to properly enter the drain reservoir, the condensate line to the drain must always be installed below the bottom of the vessel to be drained. It is equally important to provide a means for the air that is contained in the reservoir to escape (vent) as the condensate enters the reservoir. If the air cannot escape, the condensate will not enter the reservoir. Below are suggestions on how to best install the drain on typical types of vessels that have to be drained of condensate. However, it is possible to install the drain without a balance line (Dwg. not shown), providing the condensate enters the top inlet and the flow rates are less than 9 GPH (750 SCFM for an aftercooler or 1,500 SCFM dryer) for a 1/2" drain line and 19 GPH (1,500 cfm for an aftercooler or 3,000 SCFM dryer) for a 3/4" line. The use of unions and shut-off valves are recommended for both the condensate line and the balance line.

RECEIVER TANK

The preferred installation for this drain on a receiver tank is having the condensate enter the top inlet port and having the balance line go back to the tank at a position that is above the level of the condensate. (See Dwg. 1).

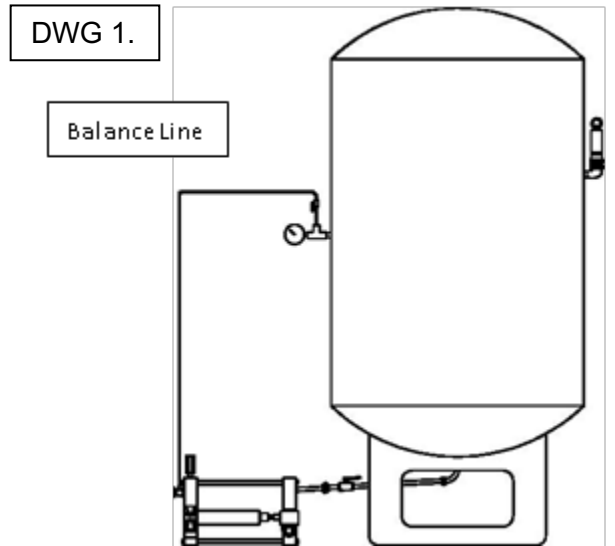

FILTER and AFTERCOOLER MOISTURE SEPARATOR

If a cyclone separator or filter has pipe plugs located in the top of the head, the plug closest to the discharge pipe should be removed and the balance line should be installed (Dwg. 2). If there is no provision on the cyclone separator or filter for a balance line, install it in the discharge side of the pipeline and as close to the cyclone separator as possible.

REFRIGERATED DRYER

If a balance line is required, it must be connected to the port located on top of the separator that is closest to the discharge side (Dwg. 2), or between the separator and the air-to-air heat exchanger. If a port is not available as described above, then venting to atmosphere is recommended. When venting to atmosphere, the condensate should enter through the bottom entry port on the drain. The bleed or needle valve is installed on the 1/8" NPT vent port and allows the air in the drain reservoir to escape to the atmosphere (Dwg 3). The bleed valve (not included) should be adjusted so that only 3 to 5 bubbles per second are visible. It is not recommended to install a vent line downstream from the dryer. The vent line can be a conduit for transferring moisture from the drain to the previously dried air. This can result in unwanted moisture being sent down stream.

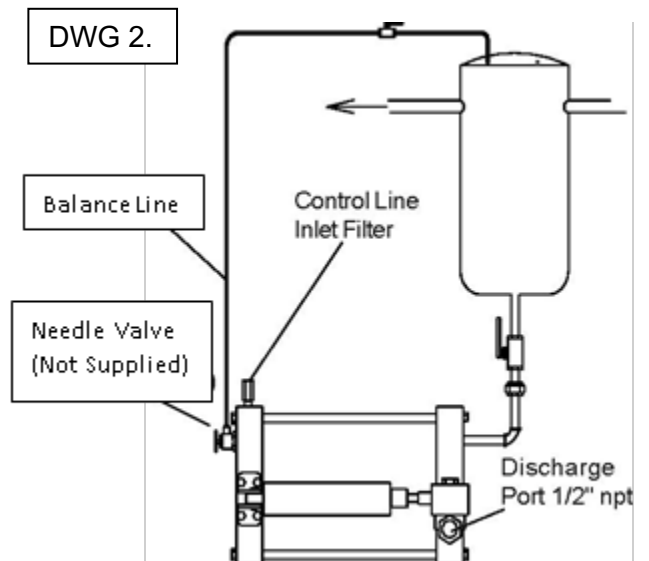

INTERCOOLERS

Install the condensate drain line into the upper port only. This will prevent the possibility of condensate being drawn back into the intercooler on some systems. It is important that the vent line be installed on the same stage that is being drained or to atmosphere.

BALANCE LINE

As mentioned above, both the use and the placement of a balance line is very important. Most drain failures are the result of an improper balance line installation. The balance line should be 1/4" tubing or larger, and installed on top of a pipe or vessel, not the bottom. A needle valve is recommended for controlling the air flow. Avoid having any loops or low areas in the balance line that might allow moisture to collect in the line and prevent the passage of air from the drain's reservoir.

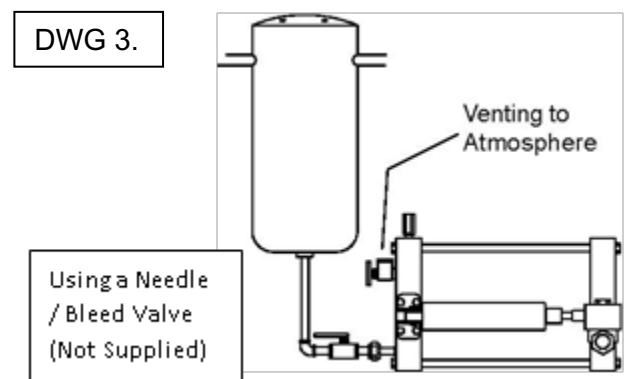

GENERAL SPECIFICATIONS

Inlets: Two (2) 3/4" NPT (BSPP Optional)
 Outlet: 1/2" NPT (BSPP Optional)
 Power: Clean, Dry Air: 60 - 130 PSI (Standard Design)
 40 – 130 PSI (Low Control Pressure Design Option)
 Operating Pressure: 0 to 250 PSI
 Vacuum and High Pressure Designs Available
 Operating Temperature: 32° to 180° F.
 Optional Immersion Heater Available
 Weight: 17 lbs. (Shipping)
 26 lbs. Filled & Installed
 Discharge: 24 ounces per cycle
 Capacity: 6,600 SCFM at aftercooler*
 *Capacity may be more or less depending on application

MATERIALS

Reservoir: Aluminum and Composite
 Stainless Steel and Nickel-plated Optional
 Drain Valve: Bronze w/SS Ball and Stem (Full SS Optional)
 Trigger Float: Stainless Steel
 Trigger Seat: Stainless Steel
 Trigger Seal: Viton®
 Control Tubing: Nylon 66
 Stainless Steel Tubing and Fittings Optional

MODEL CONFIGURATION

RD11	- LP	T	- A	- H	- V	- SSV SSE SS	NPT BSPP
------	---------	---	--------	--------	--------	-----------------------	-------------

EXAMPLE: RD13-T-NPT

LEGEND:

- LP** - Low Control Pressure Design (40-130 PSIG)
- T** - Test Button (Standard)
- A** - High Level Alarm
- H** - Heater
- V** - Valve Open Indicator
- SSV** - Stainless-Steel Valve
- SSE** - Stainless-Steel Valve and Control Tubing and Fittings
- SS** - Complete Stainless-Steel Construction
- NPT** - NPT Process Connections
- BSPP** - BSPP Process Connections

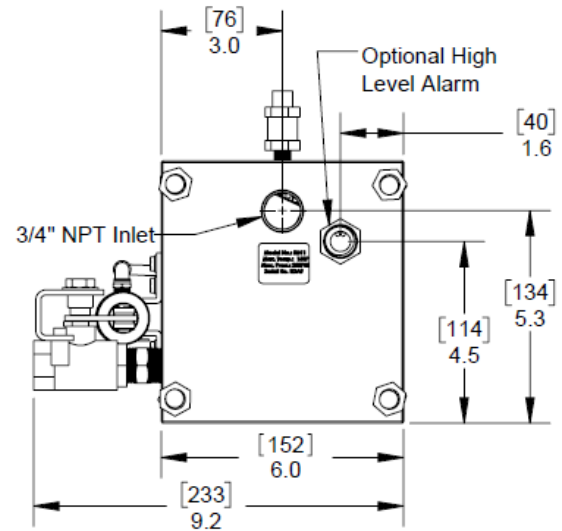
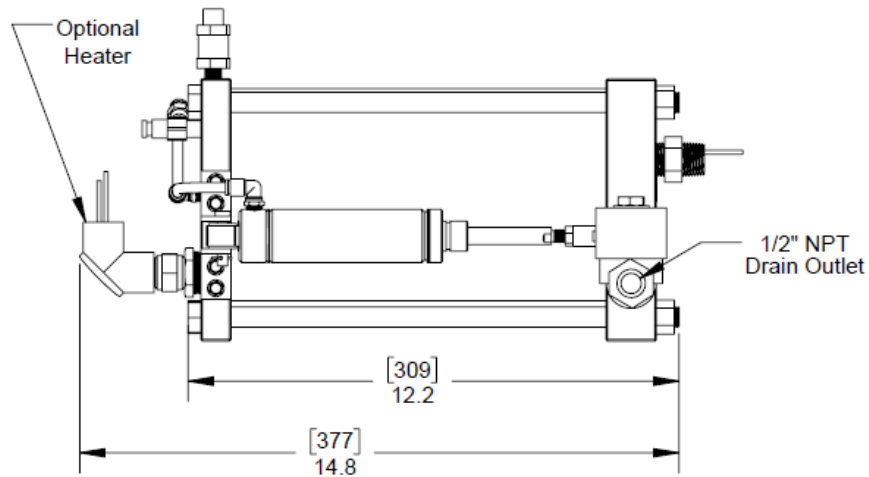
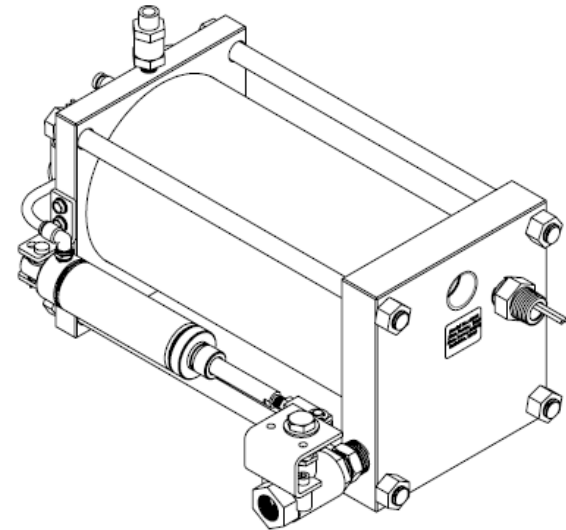
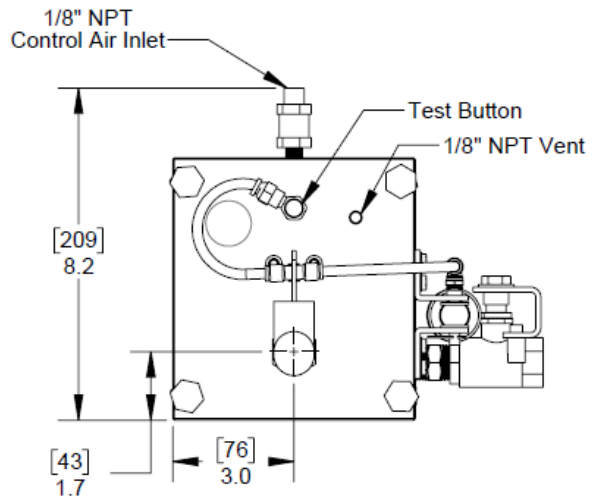

DRAWN BY: WDN	AIR SYSTEM PRODUCTS
DATE: 10/13/20	Lancaster, NY 14086 USA
	www.airsyspro.com
TITLE: Robo-Drain RD11-T-NPT	
Dimensional Drawing	
DWG.: RD11-T-A-H-NPT	REV. -

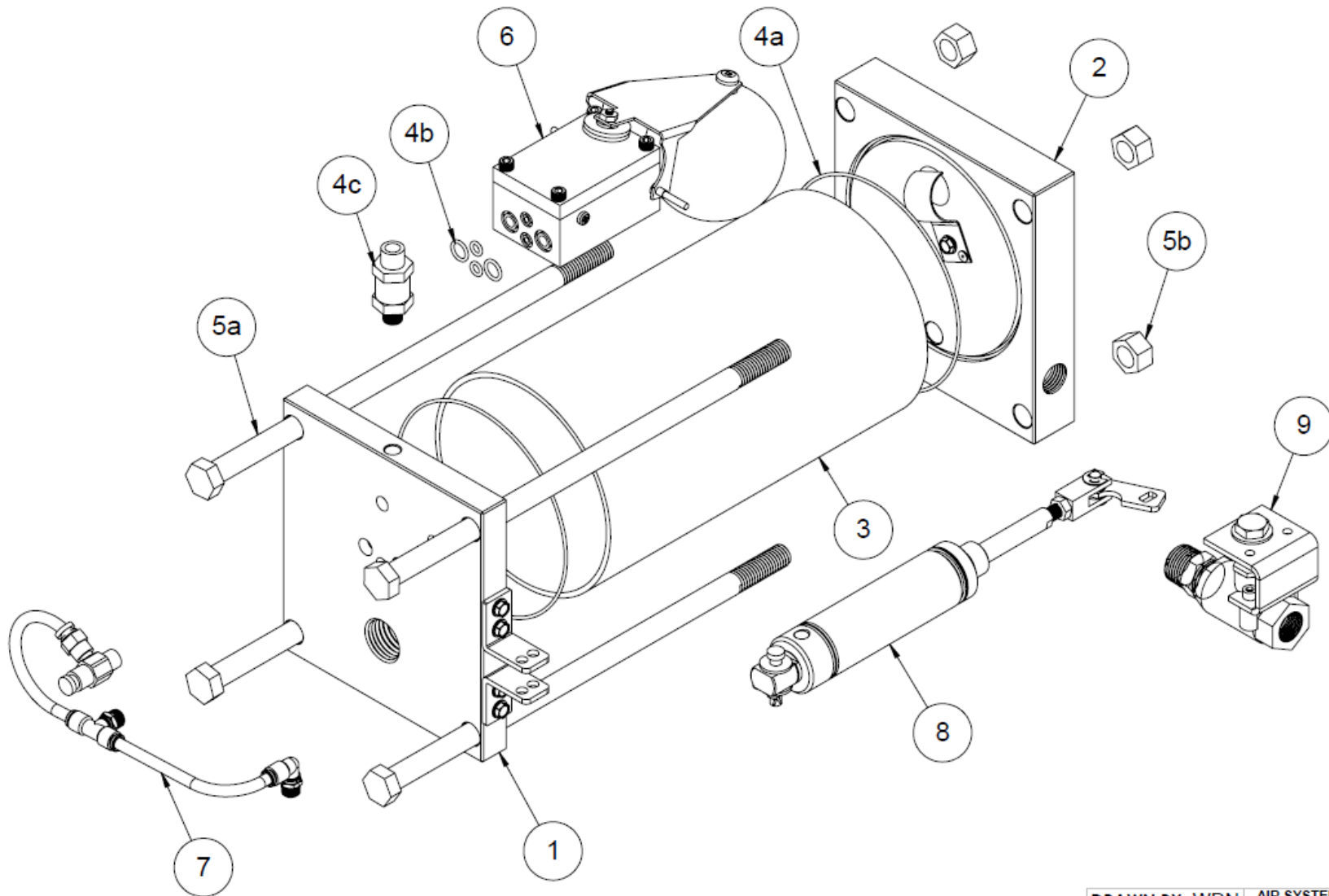

DRAWN BY: WDN	AIR SYSTEM PRODUCTS
DATE: 10/13/20	Lancaster, NY 14086 USA
	www.airsyspro.com
TITLE: RD11-T Exploded Parts Drawing	
DWG.: RD11-T-NPT-EXP REV. -	

SPARE PARTS

(Refer to RD11-T-NPT-EXP drawing on previous page.)

Item No.	Qty.	Part No.	Description
1	1	RDP-H2-KIT	Control Head Assembly
2	1	RDP-H1-KIT	Inlet Head Assembly
3	1	SSP-COCYL	Translucent Cylinder
4a	2	ED-G	Cylinder O-Rings
4b	2/2	RDP-VHG2, RDP-VHG3	Trigger Assembly O-Rings
4c	1	RDP-FILTER	Control Air Inlet Filter
5a,b	4/16	RDP-BOLT-KIT	Bolt/Nut Kit
6	1	RD11-FA1	Float and Trigger Block Assembly
7	1	RDP-FIT-KIT	Control Tubing Assembly
8	1	RDP-AC-KIT	Air Actuator Assembly
9	1	RDP-BV-KIT	Ball Valve Assembly

MAINTENANCE

The Robo-Drain has been designed and continuously improved to provide many years of trouble-free service. Most Robo-Drains outlast the life of the compressor that it is serving.

Still, the Robo-Drain is a mechanical device and routine inspection and maintenance are important and recommended.

Weekly/Monthly

1. Use the test button to ensure the drain valve opens and closes.
2. Inspect interconnecting piping and tubing to ensure there are no leaks or damage.

Annually

1. Use the test button to ensure the drain valve opens and closes.
2. Inspect interconnecting piping and tubing to ensure there are no leaks or damage.
3. Replace Control Air Inlet Filter.
4. Check the four body bolts to ensure tight.
5. On the standard Robo-Drain with the translucent vessel, if the condensate level isn't visible due to vessel coated with contamination, it is recommended to remove the drain from service and follow the simple disassembly instructions to permit the vessel to be thoroughly cleaned.
6. With the drain disassembled, exercise the float assembly to ensure it moves freely.
7. Again, with the drain disassembled, ensure the float is securely attached to the float bracket.



AIR SYSTEM PRODUCTS

51 Beach Avenue
Lancaster NY USA
P: +1 716-683-0435
www.airsyspro.com