



an EnPro Industries company

QGD Series

Direct Drive Air Compressors



Instruction Manual

This manual contains important safety information and should be made available to all personnel who operate and/or maintain this product. Carefully read this manual before attempting to operate or perform maintenance on this equipment.

Manual No. 65113-1A

May 2009 Edition

Table of Contents

Section I - General Information

Safety Alert Symbols	1
Safety Precautions	2
Spare Parts Ordering Information	3
Serial/Model Identification Plate	3
Royal Blue Warranty	4

Section II - Description

General Description	6
The Compression Cycle	6
Air Flow	7
Cooling System	7
Air-cooled Fluid Coolers	7
Aftercoolers	7
Moisture Separator.....	7
Capacity Control System.....	8
Controller Options.....	8
Standard Control Lights, Indicators & Gauges.....	9
Operating Modes.....	10
Electrical System.....	11

Section III - Installation

Receiving	12
Moving the Unit to the Installation Site.....	12
Location.....	13
Shipping Supports.....	14
Piping Connections	14
Piping Fit-up.....	14
Pressure Vessels	14
Relief Valves	15
Electrical	15
Pneumatic Circuit Breakers or Velocity Fuses	16
Guards.....	16
Manual Vent and Shutoff Valve	16
Compressor Rotation	17
Fan Rotation	17

Section IV - Operating Procedures

Prior to Starting	18
Starting the Compressor	19
Stopping the Compressor.....	19
Emergency	19
HMI Control Panel Operation	20

Table of Contents

Section V - Servicing

Preparing for Maintenance or Service	26
Safety	26
Maintenance Schedule	27
Water Removal	28
Air/Fluid Separator	28
Air Filter	28
Changing the Compressor Fluid	29
Shaft Seal.....	30
Differential Pilot Valve	32
Pressure Setting.....	32
Electronic Control.....	33
Air and Fluid Tubing.....	33

Section VI - Compressor Fluids

Fluid Specifications.....	36
Lubrication.....	37
Fluid Level	37
Fluid Filter	38
Factors Affecting Fluid Life.....	38
Fluid Analysis Program - General	39
QuinSyn Plus	40
QuinSyn PG	41
QuinSyn XP.....	42
QuinSyn F	43
QuinSyn Flush.....	43
Cleaning and Flushing With QuinSyn Flush	44
Converting to QuinSyn PG	45
Converting to QuinSyn XP	46
Converting to QuinSyn Plus	46
Sampling Procedures	47
Understanding the Analysis Report.....	49
Fluid Parameters	50

Section VII - Troubleshooting

Troubleshooting	52
-----------------------	----

Appendix A - Dimensional Drawings

QGD 20/25/30	58
QGD 20/25/30 (tank mounted)	59
QGD 40/50.....	60

Appendix B - Technical Data

QGD-20.....	62
QGD-25.....	63
QGD-30.....	64
QGD-40.....	65
QGD-50.....	66

- Safety Alert Symbols
- Safety Precautions
- Spare Parts Ordering Information
- Serial/Model Identification Plate
- Standard Warranty

Safety Alert Symbols

IMPORTANT!

Throughout this manual we have identified key hazards. The following symbols identify the level of hazard seriousness:



DANGER!

This symbol identifies immediate hazards which ***will*** result in severe personal injury, death or substantial property damage.



WARNING!

This symbol identifies hazards or unsafe practices which ***could*** result in personal injury, death or substantial property damage.



DANGER!

This symbol identifies life threatening electrical voltage levels which ***will*** result in severe personal injury or death. All electrical work ***must*** be performed by a qualified electrician.



CAUTION!

Identifies hazards or unsafe practices which ***could*** result in minor personal injury or property damage.



CAUTION!

This symbol identifies hot surfaces which ***could*** result in personal injury or property damage.

 **NOTICE!**

Identifies important installation, operation or maintenance information which is not hazard related.

Section I - General Information

Safety Precautions

Read this manual and follow all instructions prior to installing or operating the compressor.

Listed below are some, but not all, safety precautions that must be observed with compressors and compressed air systems.



WARNING!

Failure to follow any of these precautions may result in severe personal injury, death, property damage and/or compressor damage.

- ◆ Air from this compressor will cause severe injury or death if used for breathing or food processing. Air used for these processes must meet OSHA 29 CFR 1910.134 or FDA21XDE178.3570 regulations.
- ◆ Disconnect and lockout all power supplies to the compressor plus any remote controllers prior to servicing the unit.
- ◆ Never assume it is safe to work on the compressor because it is not operating. Many installations have automatic start/stop controls and the compressor may start at any time.
- ◆ This compressor is designed for use in the compression of normal atmospheric air only. No other gases, vapors or fumes should be exposed to the compressor intake, nor processed through the compressor.
- ◆ Relieve all pressure internal to the compressor prior to servicing. Do not depend on check valves to hold system pressure.
- ◆ A properly sized pressure relief valve must be installed in the discharge piping ahead (upstream) of any shutoff valve (block valve), heat exchanger, orifice or any potential blockage point. Failure to install a pressure relief valve could result in the rupturing or explosion of some compressor component.
- ◆ Do not change the pressure setting of the pressure relief valve, restrict the function of the pressure relief valve, or replace the pressure relief valve with a plug. Over pressurization of system or compressor components can occur, resulting in death, severe personal injury or property damage.
- ◆ Never use plastic pipe, rubber hose, or soldered joints in any part of the compressed air system. Failure to ensure system compatibility with compressor piping is dangerous.
- ◆ Never use a flammable or toxic solvent for cleaning the air filter or any parts.
- ◆ Do not remove any guards or cabinet panels or attempt to service any compressor part while the compressor is operating.
- ◆ Do not operate the compressor at pressures in excess of its rating.
- ◆ Observe control panel displays daily to ensure compressor is operating properly.
- ◆ Follow all maintenance procedures and check all safety devices on schedule.
- ◆ Never disconnect or tamper with the high air temperature (HAT) sensors.
- ◆ Compressed air is dangerous, do not play with it.

Spare Parts Ordering Information

- ◆ Use the correct fluid at all times.
- ◆ Do not rely on the discharge air line check valve.
- ◆ Do not override any safety or shutdown devices.
- ◆ Keep the doors closed (on an enclosed unit) during operation and stay away from an unenclosed compressor in operation. The operating temperature of some components is sufficient to burn the skin.

NOTICE!

These instructions, precautions and descriptions cover standard Quincy manufactured QGD™ Series air compressors. As a service to our customers, we often modify or construct packages to the customers specifications. This manual may not be appropriate in those cases.

NOTICE!

Every effort has been taken to ensure complete and correct instructions have been included in this manual, however, possible product updates and changes may have occurred since this printing. Quincy Compressor® reserves the right to change specifications without incurring any obligation for equipment previously or subsequently sold. Not responsible for typographical errors.

Quincy Compressor maintains replacement parts for Quincy compressors and accessories. A repair parts list is shipped with all new machines. Order parts from your Authorized Quincy distributor. Use only genuine Quincy replacement parts. Failure to do so may void warranty.

Serial/Model Identification Plate

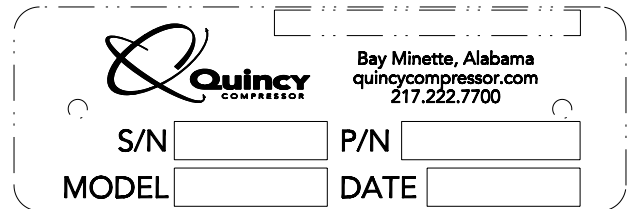

The image shows a rectangular identification plate with rounded corners and a dashed border. At the top left is the Quincy Compressor logo, which consists of a stylized 'Q' followed by the word 'Quincy' in a bold font and 'COMPRESSOR' in a smaller font below it. To the right of the logo, the text reads 'Bay Minette, Alabama', 'quincycompressor.com', and '217.222.7700'. Below this information are four input fields arranged in a 2x2 grid. The top row contains 'S/N' followed by a rectangular box and 'P/N' followed by a rectangular box. The bottom row contains 'MODEL' followed by a rectangular box and 'DATE' followed by a rectangular box.

Reference to the machine MODEL, SERIAL NUMBER and DATE OF ORIGINAL START-UP must be made in all communication relative to parts orders. A model/serial number plate is located on the frame or in the upper right corner of the control panel door.

Section I - General Information



Royal Blue Warranty

Quincy Compressor®

Industrial Screw Products

QGD™ - Rotary Screw Air Compressors

Seller warrants products of its own manufacture against defects in workmanship and materials under normal use and service, as follows:

QGD™ Packaged Compressors - Twelve (12) months from date of start-up or twenty-four (24) months from date of shipment from the factory, whichever occurs first.

Airend on Packaged Compressors (for service at full-load pressure at or below 150 psig) - Ten years (120 months) from date of startup (not to exceed 126 months from date of shipment from the factory).

Airend on Packaged Compressors (for service at full-load pressure above 150 psig) - Twelve (12) months from date of start-up or twenty-four (24) months from date of shipment from the factory, whichever occurs first.

Air/fluid Reservoir Tank - Five years (60 months) from date of start up (not to exceed 66 months from date of shipment), including parts and labor. In the event of a reservoir tank failure, the parts and labor coverage is limited to the reservoir tank itself and does not cover the separator element(s) or loss of fluid.

Air and Fluid Heat Exchangers - Five years (60 months) from date of start up (not to exceed 66 months from date of shipment), including parts and labor for the first twelve (12) months, parts only after twelve (12) months. In the event of a heat exchanger failure, the parts and labor coverage is limited to the heat exchanger itself and does not cover the loss of fluid.

Drive Motor - Five years (60 months) from date of start up (not to exceed 66 months from date of shipment), including parts and labor. Royal Blue warranty does not cover medium voltage (above 575 volt, 3 phase) motors. Before any motor repairs or replacements are performed, the factory must be contacted at the time of failure in order to approve any further action.

Drive Coupling Element - Five years (60 months) from date of start up (not to exceed 66 months from date of shipment), including parts and labor. (Machine must be installed and operated in accordance with the Operator's Manual.)

Variable Speed Drives (if applicable) - Five years (60 months) from date of start up (not to exceed 66 months from date of shipment), including parts & labor for the first year (12 months), parts only for the remainder of the warranty period. Unit must be installed indoors in a well ventilated environment & a line reactor purchase (from Quincy Compressor) is required.

Remanufactured Airend - Twelve (12) months from date of shipment from the factory.

Parts - Ninety (90) days from date of Distributor sale or one (1) year from date of factory shipment.

With respect to products not manufactured by Seller, Seller will, if practical, pass along the warranty of the original manufacturer.

The terms of coverage for the Royal Blue Warranty are listed below. Failure to follow the terms will invalidate the Royal Blue Warranty.

AUTHORIZED START-UP REQUIRED:

A properly completed start-up report and the Royal Blue Warranty registration form must be submitted by an authorized Quincy distributor to the Quincy Compressor Bay Minette office within thirty (30) days of start-up. Start-up reports must be submitted on Q-Serv.

GENUINE PARTS AND FLUIDS

The compressor must be maintained with QuinSyn-PG (8,000 hours maximum), QuinSyn-XP (12,000 hours maximum), QuinSyn-Plus (8,000 hours maximum) or QuinSyn-F fluid (4,000 hours maximum). Maximum fluid change intervals are noted per fluid. Actual fluid change interval is to be determined by fluid sampling report, not to exceed maximum fluid change interval. Fluid samples must be taken every 2,000 hours or as directed by the analysis report.

Only genuine Quincy Compressor maintenance and replacement parts may be used on the compressor.



Royal Blue Warranty

Quincy Compressor®

Industrial Screw Products

QGD™ - Rotary Screw Air Compressors

Normal rules of warranty apply regardless of coverage length. Inlet valves, fluid pumps and shaft seals are covered by the standard (1 year) warranty terms and are not included in the Royal Blue Warranty program. The Royal Blue Warranty is non-transferable.

The customer and/or Quincy Distributor must keep copies of all maintenance records, parts purchases and sampling reports. The following records will be required for warranty air end replacement and/or warranty claim consideration and should be submitted to the Quincy Compressor Customer Service Department:

- ◆ A completed Air end Failure Information form.
- ◆ A copy of the Royal Blue Warranty Registration/ Agreement form.
- ◆ Copies of all maintenance logs for the unit.
- ◆ Proof of purchase of genuine Quincy parts and fluids.
- ◆ Copies of all fluid analysis reports.

Notice of the alleged defect must be given to Seller in writing with all identifying details including serial number, model number, type of equipment and date of purchase, within thirty (30) days of the discovery of same during the warranty period.

Seller's sole obligation on this warranty shall be, at its option, to repair, replace or refund the purchase price of any product or part thereof which proves to be defective. If requested by Seller, such product or part thereof must be promptly returned to Seller, freight collect for inspection.

Seller warrants factory repaired or replaced parts of its own manufacture against defects in material and workmanship under normal use and service for ninety (90) days or for the remainder of the warranty on the product being repaired, whichever is longer.

This warranty shall not apply and Seller shall not be responsible nor liable for:

- a) Consequential, collateral or special losses or damages;
- b) Equipment conditions caused by fair wear and tear, abnormal conditions of use, accident, neglect or misuse of equipment, improper storage or damages resulting during shipment;
- c) Deviation from operating instructions, specifications, or other special terms of sales;
- d) Labor charges, loss or damage resulting from improper operation, maintenance or repairs made by person(s) other than Seller or Seller's authorized service station.
- e) Improper application of product.

In no event shall Seller be liable for any claims, whether arising from breach of contract or warranty of claims of negligence or negligent manufacture, in excess of the purchase price.

NOTICE!

Quincy Compressor reserves the right to modify or withdraw this Royal Blue Warranty program at any time on units not already covered by this ROYAL BLUE WARRANTY program.

Section II - Description

- General Description
- The Compression Cycle
- Air Flow
- Cooling System
- Capacity Control System
- Controller Options
- Standard Control Lights, Indicators & Gauges
- Operating Modes
- Electrical System

The Compression Cycle

The compression cycle of a rotary screw compressor is a continuous process from intake to discharge with no reciprocating mechanisms starting and stopping as found in reciprocating compressors. The compressor consists of two rotors in constant mesh, housed in a cylinder with two parallel adjoining bores. The male drive rotor has four or five lobes that mesh with six flutes in the female rotor. All parts are machined to exacting tolerances.

As the rotors rotate, (male-clockwise as viewed from the power input end) air is drawn into the cylinder through the inlet port located at the power input end. A volume of air is trapped as the rotor lobes pass the inlet cut off points in the cylinders. Compression occurs as the male rotor rolls into the female flute, progressively reducing the space thereby raising the pressure. Compression continues until the lobe and flute pass the discharge port. The compressed air is then discharged into the air/fluid reservoir. There are four or five complete compression cycles for each complete rotation of the male rotor.

General Description

The QGD™ line of rotary screw compressors covers a horsepower range of 20 to 50. These truly direct drive compressors have standard full load pressure ratings of 100, 125 and 150 PSIG. The large, 120/127mm rotors allow Quincy to operate these compressors at lower speeds than competitive makes.

The compressor is a single stage, positive displacement, fluid-flooded rotary screw type unit, consisting of two precision-machined rotors. The male rotor is driven through a coupling arrangement.

All components are attached to a heavy-duty steel frame. Controls and indicators are arranged on a control panel. Acoustical cabinets are standard on QGD compressors. QGD-20, 25 and 30 horsepower units are available mounted on a 120 gallon receiver tank.

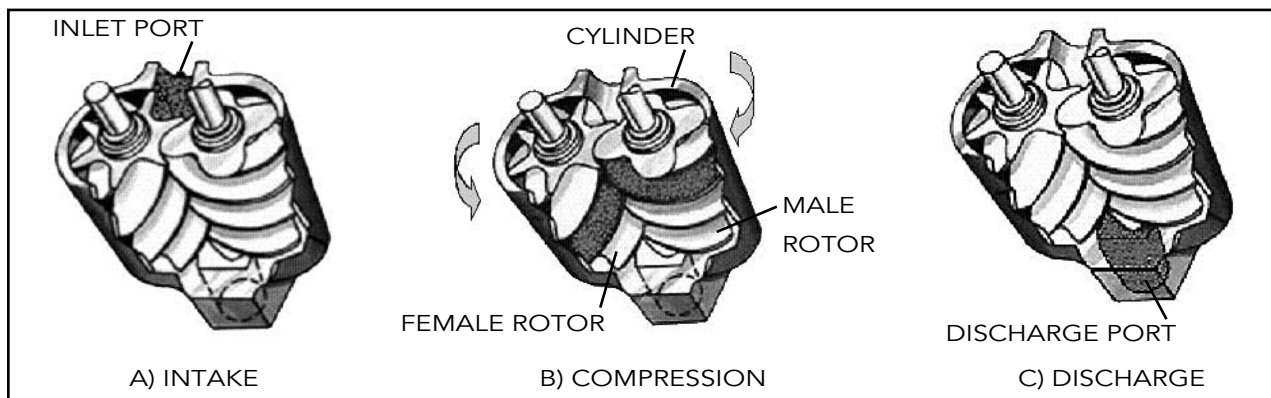

Compression Cycle

Air Flow

When the compressor is operating, a partial vacuum is produced at the compressor inlet. Air entering via the air filter flows through the inlet valve into the rotor housing where it is compressed,

then discharged into the air/fluid reservoir. Compressed air passes through the air/fluid separator, then through a minimum pressure check valve, through the aftercooler and moisture trap to the service connection.

Cooling System

Air-cooled Fluid Coolers

The air-cooled fluid cooler and aftercooler are finned aluminum plate design. QGD 20, 25 and 30 horsepower models use a one-piece combination cooler/aftercooler, while QGD 40 and 50 horsepower models use a two-piece design. Ambient air is induced through the fins by a centrifugal fan, cooling the fluid and air in the plates. To maintain proper compressor operation, the ambient air temperature should not exceed the temperatures listed in Appendix B - Technical Data. The cooler fins must be kept clean at all times. Fluid leaving the receiver passes through a thermal mixing valve before traveling on to the cooler. The purpose of the thermal valve is to maintain a minimum fluid discharge temperature at the compressor of approximately 180°F.

Aftercoolers

Aftercoolers reduce the amount of water in the discharge air. They are used to lower the temperature of the discharge air thereby condensing water vapor from the compressed air. This allows most of the contained water to be trapped and expelled from the unit, reducing water related problems downstream.

Moisture Separator

A combination moisture separator and water trap is provided for collecting and expelling water to the customer's drain.

Section II - Description

Capacity Control System

As the motor starts driving the compressor rotors, air is drawn in, compressed and discharged into the system downstream. When the air pressure at the service connection exceeds the set point of the pilot valve (normally 100 PSIG), the valve opens and passes a controlled volume of air to the inlet valve air cylinder.

The air forces a piston to move within the cylinder, closing the inlet valve. The compressor will continue to run, matching air demand with air delivery by constantly adjusting the position of the inlet valve. The inlet valve regulates compressor capacity between 100% and nearly 0% of rated delivery.

When maximum pressure (typically 15 PSIG above normal full load pressure) has been obtained in the air system, complete compressor unloading occurs. The pressure switch located in the control panel sends a signal to the control and the solenoid valve opens, venting the residual pressure through the blowdown valve. At the same time, control air from the reservoir check valve is directed through the solenoid to the inlet valve air cylinder. The inlet valve is held in a closed position preventing the intake of air into the compressor and serving as a check valve preventing reverse air/fluid flow through the inlet valve and air filter.

Controller Options

Standard QGD™ compressors are equipped with either an electronic controller with an HMI control panel which utilizes a microprocessor to control the

compressor or standard controls with a selector switch for setting the operating mode and lights, indicators and gauges for monitoring compressor operation.

Standard Control Lights, Indicators & Gauges

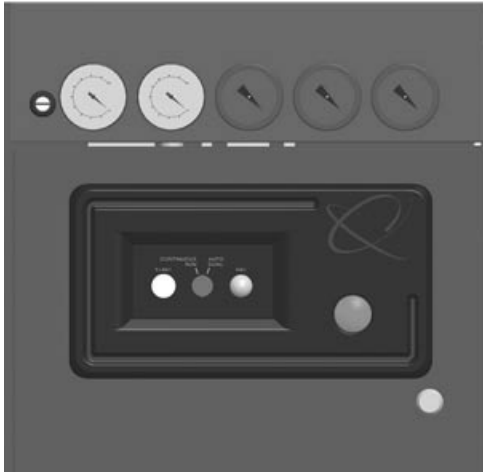

Main Power on Light

Indicates when power from the main disconnect switch has been turned on and there is live power at the compressor starter and control panel. This light will remain on as long as there is power to the unit, regardless of the position of the selector switch.



CAUTION!

Always check power supply disconnect. The power on light may be inoperable.

High Discharge Air Temperature Light

Indicates when the unit has sensed an unusually high discharge temperature.

Separator Gauge

This gauge indicates excessive pressure differential across the air/fluid separator element. It is used to determine separator element change intervals.

Air Filter Gauge

This gauge indicates excessive pressure differential across the air filter element. It is used to determine air filter element change intervals.

Hourmeter

Indicates actual hours of operation on the compressor.

Air Pressure Gauge

This gauge indicates air pressure available for distribution to the service line.



CAUTION!

Gauge may not register when the unit is unloaded or off. Make certain all air pressure is relieved prior to servicing.

Percent Capacity Gauge

This gauge is graduated in percent of the total capacity of the unit. Readings taken from this gauge give an indication of the amount of air being used.

Discharge Temperature Gauge

This gauge indicates the temperature of the air/fluid mixture as it discharges from the compressor. The normal reading is 180-200°F.

Section II - Description

Operating Modes



WARNING!

Never assume it is safe to work on a compressor because it is not operating. It may be in standby mode and could restart at any time. Follow all safety instructions in Section V - Maintenance or Service Preparation.

Auto Dual

With the controller set to run in auto dual mode, a solid state timer is activated when the unload pressure is reached. This timer is adjustable within a ten (10) minute range. When the timer reaches the end of its delay period, the compressor will automatically shut down and assume a standby mode. Upon a drop in system air pressure (to the load set point), the compressor will restart automatically. The timer should be set during unit start-up to a minimum of six (6) minutes.

During the unloaded/timing mode, if plant pressure drops, the compressor will continue to operate, resetting the timer and instructing the inlet valve to reopen.

Continuous Run

When set to run in Continuous Run mode, the compressor operates continuously, matching air demand as a differential pilot valve controls the position of the inlet valve. When maximum system pressure is reached, the compressor unloads, venting the air/fluid reservoir and, although the compressor continues to run unloaded, no air is compressed.

Load/No Load

In the Load/No Load mode, the compressor does not modulate the inlet valve. The valve is either fully open or it is closed. If system demands include regular periods of air usage at less than full load, a large compressed air storage capability is required with this type of control. Without adequate storage, rapid cycling may occur. This will cause wide system pressure fluctuations that may affect the performance of equipment using the compressed air. Load/No Load works with Auto Dual control to turn the compressor off during extended periods of no demand.

Electrical System

Electrical system diagrams are shown in the parts manual sent with the compressor. The appropriate diagram is also included in the control panel on all Quincy QGD™ compressors.

NOTICE!

Due to continuous product improvements and updates, it is suggested that the wiring diagram included in the control panel be used when servicing the electrical control.

Standard QGD drive motors are open, drip proof (ODP), 3600 RPM motors with a maximum ambient temperature rating of 104°F (40°C).

QGD™ series compressors utilize 460V incoming power through a full voltage (across the line) starter. A dual output transformer in the control panel reduces the voltage to 120/24 VAC for the various controls on the unit. These controls include the PLC, HMI, high air temperature safety switch and solenoid. Other incoming line voltages and a wye-delta starter are available as options. The compressor is provided with a NEMA 4 enclosure.



DANGER!

High voltage could cause death or serious injury. Disconnect all power supplies before opening or servicing the electrical enclosure.

High Air Temperature Switch

A high air temperature (HAT) switch is standard on QGD™ units. The HAT is located on the air/fluid reservoir and protects the unit by sensing unusually high temperatures and shutting the unit down. The HAT is set to trip at approximately 235°F and is nonadjustable.



WARNING!

Never remove, bypass or tamper with the HAT switch. Failure to provide this safety feature could cause death or serious injury and property damage. If the compressor is shutting down due to high temperature, contact a qualified service technician immediately.

Section III - Installation

- Receiving
- Moving the Unit to the Installation Site
- Location
- Shipping Supports
- Piping Connections
- Pressure Vessels
- Relief Valves
- Electrical
- Pneumatic Circuit Breakers or Velocity Fuses
- Guards
- Manual Vent and Shutoff Valves
- Compressor Rotation
- Fan Rotation

Receiving

Upon receipt, immediately inspect the compressor for any visible damage that may have occurred during shipment. If visible damage is found, the delivering carrier should make a notation on the freight bill and the customer should request a damage report. If the shipment is accepted and damage is found later, it is classified as concealed damage. Concealed damage should be reported to the delivering carrier within 15 days of delivery. The delivering carrier must

prepare a damage report. Itemized supporting papers are essential to filing a claim.

Read the compressor nameplate to be sure the compressor is the model and size ordered and that optionally ordered items are included.

Check the reservoir and pressure relief valves to be sure they are adequate for the pressure at which you intend to operate.

Moving the Unit to the Installation Site

Forklift slots are provided on both sides of the main frame. Use of chains and slings should be limited to the main frame. Do not attempt to lift the unit by attaching to any components. Optional lifting eyes are available.

NOTICE!

See Appendix A and B for detailed technical information and dimensions.



CAUTION!

Improper lifting may result in component, system damage or personal injury. Follow good shop practices and safety procedures when moving the unit.

Location

Locate the compressor on a level surface in a clean, well-lit and well-ventilated area. Allow sufficient space (four feet of clearance on all sides and top of the compressor) for safe and proper daily inspection and maintenance. The entire length of the frame base must be supported. Shim where necessary but do not use wood.



WARNING!

Under no circumstances should a compressor be installed in an area exposed to a toxic, volatile or corrosive atmosphere, nor should toxic, volatile or corrosive agents be stored near the compressor.

Ambient temperature should not exceed 110°F. High ambient temperatures may result in a high air temperature shutdown. All models are intended for indoor installation, however, it is possible, with certain modifications, to accommodate some outdoor locations. Cabinet models are water-resistant but not water tight. Sheltering from rain, snow and freezing temperatures is mandatory.



WARNING!

Do not operate in temperatures below 34°F or above the limits outlined in Appendix B - Technical Data.

Do not locate the unit where the hot exhaust air from other compressors or heat generating equipment may be drawn into the unit. Never restrict the flow of exhaust air from the fluid cooler or cooling fan. Heated exhaust air must be exhausted outside to prevent high temperature conditions in the compressor room. If the room is not properly ventilated, compressor operating temperatures will increase and cause a high temperature shutdown.



CAUTION!

Clean, fresh air, of sufficient quantity, is required for proper compressor operation.

In high humidity areas, avoid placing the compressor in a basement or other damp locations. Control the compressor temperatures and monitor compressor fluid for signs of water contamination. Fluid and filter changes may need to be increased, and/or fluid may need to be changed to QuinSyn-PG in high humidity areas.

Quincy QGD™ compressors are essentially vibration free, however, some customers may choose to bolt the unit to the floor to prevent the accidental breakage of piping or electrical connections as a result of being bumped. Use only lag bolts to secure the unit. Do not pull the bolts down tight. Overtightening the lag bolts may place the frame in a twist or bind causing breakage of fluid coolers, piping and reservoirs.



WARNING!

Removal or painting over safety labels will result in uninformed conditions. This could result in personal injury or property damage. Warning signs and labels shall be provided with enough light to read, conspicuously located and maintained for legibility. Do not remove any warning, caution or instructional material attached.

Section III - Installation

Shipping Supports

Shipping supports are used to secure the motor and airend during shipping to prevent damage to the motor, airend, reservoir and the connections to these components.

The shipping supports are painted red and are located near the motor support.

NOTICE!

Once the compressor has been located and secured at the installation site, the shipping supports must be removed before operating the unit.

To remove the shipping supports, remove the screws attaching them to the airend and to the base.

Piping Connections

Never join pipes or fittings by soldering. Lead-tin solders have low strength, a low creep limit, and may, depending on the alloy, start melting at 360°F. Silver soldering and hard soldering are forms of brazing and should not be confused with lead-tin soldering. Never use plastic, PVC, ABS pipe or rubber hose in a compressed air system.

Piping Fit-up

Care must be taken to avoid assembling the piping in a strain with the compressor.

Piping should line up without having to be sprung or twisted into position. Adequate expansion loops or bends should be installed to prevent undue stress at the compressor resulting from the changes between hot and cold conditions. Pipe supports should be mounted independently of the compressor and anchored, as necessary, to limit vibration and prevent expansion strains. Piping should never be of smaller size than the connection on the compressor unit.

Pressure Vessels

Air receiver tanks should be in accordance with ASME Boiler and Pressure Vessel Code Section VIII.



CAUTION!

ASME coded pressure vessels must not be modified, welded, repaired, reworked or subjected to operating conditions outside the nameplate ratings. Such actions will negate code status, affect insurance status and may cause death, serious injury and property damage.

Relief Valves



Pressure relief valves are sized to protect the system. Never change the pressure setting or tamper with the valve. Only the relief valve manufacturer or an approved representative is qualified to make such a change.



DANGER!

Relief valves are to protect system integrity in accordance with ANSI/ASME B19 safety standards. Failure to provide properly sized relief valves will result in death or serious injury.

Relief valves are to be placed ahead of any potential blockage point that includes, but is not limited to, such components as shutoff valves, heat exchangers and discharge silencers. Ideally, the relief valve should be threaded directly into the pressure point it is sensing, not connected with tubing or pipe and pointed away from any personnel. Always direct discharge from relief valves to a safe area away from personnel.

Electrical

Before installation, the electrical supply should be checked for adequate wire size and capacity. During installation, a suitable fused disconnect switch or circuit breaker should be provided. Any unreasonable voltage unbalance (5%) between the legs must be eliminated and any low voltage corrected to prevent excessive current draw. The installation, electric motor, wiring and all electrical controls must be in accordance with National Electric Code, and all state and local codes. A qualified electrician should perform all electrical work. **Air compressors must be grounded in accordance with applicable codes.** See control panel for the proper wiring diagram.

Quincy would like to emphasize the importance of providing adequate grounding for air compressors. The common practice of grounding units to building structural steel may not actually provide adequate grounding protection, as paint and corrosion buildup may exist.



CAUTION!

NEMA electrical enclosures and components must be appropriate to the area in which they are installed.

Section III - Installation

Pneumatic Circuit Breakers or Velocity Fuses

Pneumatic safety devices are designed to prevent hoses from whipping, which could result in a serious or fatal accident.

The Occupational Safety and Health Act, Section 1926.303 Paragraph 7 published in Code of Federal Regulations 29 CFR 1920.1 (revised 07/01/1982), states "all hoses exceeding 1/2" inside diameter shall have a safety device at the source of supply or branch line to reduce pressure in case of a hose failure."

Guards

All mechanical action or motion is hazardous in varying degrees and needs to be guarded. Guarding shall comply with OSHA Safety and Health Standards 29 CFR 1910.219 in OSHA manual 2206 (revised 11/07/1978) and any state or local codes.



WARNING!

Cabinet panels and drive guards must be fastened in place before starting the machine and never removed before lock out/tag out of the main power supply.

Manual Vent and Shutoff Valve

Install a manual valve to vent the compressor and the compressor discharge line to atmosphere. If the air receiver tank services a single compressor, the manual valve can be installed in the receiver. When a manual shutoff valve (block valve) is used, a manual valve should be installed upstream from the valve, and a pressure relief valve installed upstream from the manual vent valve. These valves are to be designed and installed to permit maintenance to be performed in a safe manner. Never substitute a check valve for a manual shutoff valve (block valve) if the purpose is to isolate the compressor from a system for servicing.



WARNING!

Relieve compressor and system air pressure by opening the appropriate manual relief valve prior to servicing. Failure to relieve all system pressure could result in death or serious injury and property damage.

Compressor Rotation

Compressor rotation must be checked prior to start-up. Proper rotation is clockwise (as viewed from the power-input end). The power-input end of the compressor is marked with an arrow noting the proper rotation. Operating the compressor in incorrect rotation will result in extreme damage to the compressor

and warranty coverage will be voided. To check for proper rotation, jog the starter button, allowing the motor to turn 2 or 3 revolutions. Observe the drive element for correct direction. If incorrect rotation is observed, lock out power supply, reverse electrical leads L_1 and L_3 at the motor starter. Recheck for correct rotation.

Fan Rotation

QGD compressors use a centrifugal fan. Fan rotation is checked through the arrow shaped observation hole above the fan motor. The fan must rotate in the direction indicated by the arrow.

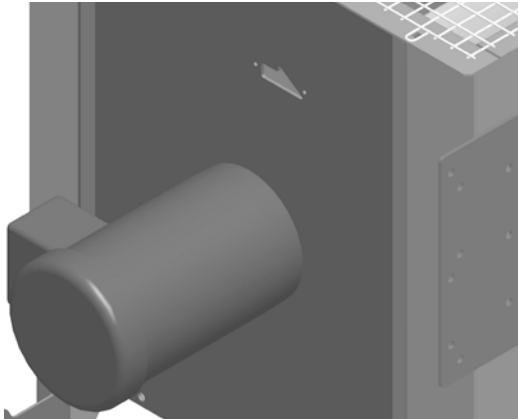

NOTICE!

Always check the fan rotation by the observation hole. Never assume the fan rotation is correct based on the induced air flow across the coolers. A centrifugal fan can pull the airflow across the coolers when rotating in either direction, however, incorrect rotation will cause a high discharge temperature.

Section IV - Operating Procedures

- Prior to Starting
- Starting the Compressor
- Stopping the Compressor
- HMI Control Panel Operation

Prior to Starting



CAUTION!

Provisions should be made to have the instruction manual readily available to the operator and maintenance personnel. If, for any reason, any parts of the manual become illegible or if the manual is lost, have it replaced immediately. The instruction manual should be read periodically to refresh one's memory. This may prevent a serious accident.

Before starting the compressor, review Sections II and III of this manual. Be certain that all installation requirements have been met and that the purpose and use of the controls are thoroughly understood. Before placing the compressor into operation, do the following:

- ◆ Remove all loose items and tools from around the compressor.
- ◆ Check fluid level in the air/fluid reservoir. See Compressor Fluid Section.
- ◆ Check the fan and fan mounting for tightness.
- ◆ Manually rotate the compressor through enough revolutions to be certain there are no mechanical interferences.
- ◆ Check all pressure connections for tightness.
- ◆ Check to make sure all relief valves are in place.
- ◆ Check to make sure all panels and guards are in place and securely mounted.
- ◆ Check fuses, circuit breakers and thermal overloads for proper size.
- ◆ Close the main power disconnect switch and jog the starter switch button to check the rotational direction of the compressor.
- ◆ Check the fan rotation.
- ◆ Remove the red shipping brackets.

Starting the Compressor

- ◆ Secure all enclosure panels on compressor.
- ◆ Open the service valve to the plant air distribution system.
- ◆ Select the mode of operation and start the compressor.
- ◆ Watch for excessive vibration, unusual noises or air/fluid leaks. If anything unusual develops, stop the compressor immediately and correct the condition.
- ◆ Control settings have been adjusted at the factory; however, they should be checked during start-up and readjusted, if necessary. Some applications may require a slightly different setting than those provided by the factory. Refer to Section VI - Servicing. Never increase air pressure settings beyond factory specifications.
- ◆ Observe compressor operation closely for the first hour of operation and frequently for the next seven hours. Stop and correct any noted problems.

Stopping the Compressor

Normal Operation

Close the service valve to the plant air distribution system. Allow the pressure to build within the reservoir and the compressor to fully unload. Press the stop button.

NOTICE!

Always close the service valve when the compressor is not being used to prevent the system's air pressure from leaking back into the compressor if the check valve leaks or fails.

Emergency

Press the emergency stop button or cut the power at the main disconnect switch or panel.

Section IV - Operating Procedures

HMI Control Panel Operation

The main display (HOME) shows the current status of the compressor.

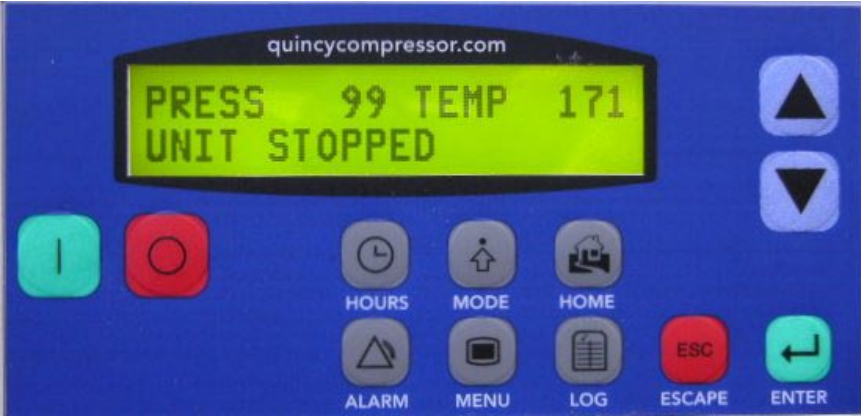

quincycompressor.com
PRESS 99 TEMP 171
UNIT STOPPED

START STOP HOURS MODE HOME ALARM MENU LOG ESCAPE ENTER

▲ ▼

Press START to start the compressor. If the pressure is above the load point, the compressor will enter an A/D (auto-dual) standby mode and will not start until the pressure lowers.

Press STOP to stop and blowdown the compressor.

Main Display (HOME)

HOURS:

Press this button to view the time remaining on the various filter elements, separators and fluid.



SE Hr8000 FF Hr1000
AF Hr2000 FL Hr8000

SE is the separator element, FF is the fluid filter, AF is the air filter and FL is the fluid.

When any of these times reaches zero (0), a message will be displayed on the main display. Press ENTER to clear the message and reset the counter to the preset values (these are set in the MENU section).

Press HOURS, then ▲ or ▼ to display the loaded, unloaded and total running hours of the compressor.



LOADED Hr 0
UNLOADED Hr 0

TOTAL HOURS: 0

ALARM:



Press the ALARM button to access the alarm log which shows the cause of the current shutdown.



Press ENTER to remove the alarm once the condition that caused the alarm has been corrected.

NOTICE!

All shutdown alarms must be cleared before the compressor will load. Press ALARM, then ENTER to clear an alarm.



NO ALARMS ACTIVE indicates that all conditions which would inhibit starting the compressor have been cleared.



Many of the following menus require a password to allow alteration of the values. If the screen shown to the left is displayed, enter password '0000'. Once entered, the password is active, allowing changes to be made without re-entering the password. If no operator input occurs for 2 minutes, the password is released.

MODE:



Press the MODE button to access the operating conditions of the compressor. There are six (6) menus in this section. Press MODE, then ▲ or ▼ to scroll through the menus. To change the values on any of these menus, press ENTER, then ▲ or ▼ to set the value, then ENTER again.

NOTICE!

If the ▲ or ▼ buttons are pressed and held, the selected value will change very rapidly. If a value is set outside the acceptable range, it will automatically revert to the default setting when ENTER is pressed.



AUTO-DUAL TIME is the time (in minutes) that the compressor will run unloaded before the motor will shutdown. When the motor shuts down, the compressor will be in standby mode and will restart when the pressure falls to the LOAD point.

AUTO_RESTART restarts the compressor following a power interruption. A setting of 0.0 turns this feature off. This timer is in seconds and can be set from 60 to 120 seconds.



Use this menu to set the load and unload pressure settings (psig) for auto-dual or continuous run mode. There must be at least 10 psi difference between these pressure settings.

Section IV - Operating Procedures



```
Net Unload: 115
Load: 105 Step: 1
```

Use this menu to set the load and unload pressure settings (psig) for compressors in network mode. *(These values should be 0 if the compressor is not running in network mode.)*

The values entered are for the base or lead compressor. The pressure settings for each compressor in the network sequence will be reduced (step down) by the step value. The step value can be set from one (1) to ten (10) psig.



```
Network Rotation
Time: 24 (hrs)
```

In network mode, use this menu to set the time period for auto-rotation of the compressors. At the end of the selected time period, the current lead compressor will be placed at the end of the operating sequence list.

NOTICE!

The accuracy of this timer depends on the accuracy of the PLC's internal clock.



```
OPERATING SEQUENCE
ABCDEF Edit: A
```

An operating sequence must be entered for compressors to run properly in network mode. The first compressor ID in the sequence is the BASE load compressor, and the last compressor ID in the sequence is the trim compressor.

Acceptable values for this menu are 'A' to 'F'. *If a value less than 'A' is entered, the last letter in the sequence is deleted and 'A' is placed in the edit space. If a value greater than 'F' is entered, 'F' will be placed in the edit location.*



```
Network Run Mode 0
0=LIFO 1=AutoRotate
```

There are two operating modes in network mode: LIFO and AutoRotate.

Select zero (0) for LIFO (last in, first out), which is a fixed sequence type. The networked compressors operate in the selected sequence.

Select one (1) for AutoRotate, which activates a rotation timer. When the timer reaches zero (0), the current base compressor is moved to the trim position.

MENU:



Press this button to access the setup menus for the compressor. There are 8 menus in this section. These include the service intervals, sensor calibration etc. Press MENU, then ▲ or ▼ to scroll through the menus. To change the values on any of these menus, press ENTER, then ▲ or ▼ to set the value, then ENTER again.



There are three operating modes available: auto-dual, continuous run and network mode. Select zero (0) for auto-dual mode, one (1) for continuous run mode, or two (2) for network mode.

Service hours are preset to default values but can be changed here, if desired.



These are count down timers and are used as service reminders. A message will be displayed on the main running menu when any of these timers reaches zero.



The pressure transducer range is 0 to 300 psi. To calibrate the pressure transducer, disconnect the pressure line to the sensor, and vent to atmosphere to zero (the number on the screen has no effect on the calibration; it is just a dummy value. Press ENTER to set the zero).



The standard temperature scale is 0 to 300°F.



To calibrate the temperature, press ENTER, then ▲ or ▼ to match the temperature at the probe.

Shutdown temperature is a preset value. During start-up, the compressor will automatically raise this setting to 250° for 2 minutes to handle overshoots.



The shutdown temperature can be altered at this menu, however, this should only be done as a last resort.

The Y/D time is the time (in seconds) that the motor remains in reduced voltage start mode before transitioning to run mode. Too large a value can cause the motor to bog-down on start. A correct value, will give a fairly smooth transition to run mode.



Each compressor in the network must have a compressor ID (a unique letter of 'A' to 'F') to run in network mode.

The HP setting, along with other compressor data, is transmitted to other compressors on the network.

Section IV - Operating Procedures

HOME:



Press the HOME button to return to the main display from any screen.

LOG:



Press the LOG button, then ▲ or ▼ to view a log of recent faults or messages. This log records up to eight messages/faults with the most recent being 1 and the oldest 8.

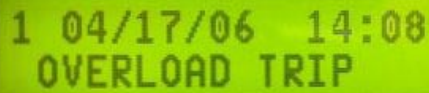

1 04/17/06 14:08
OVERLOAD TRIP



2
NO FAULT/EMPTY

Advanced Operations

ESC:



Use the ESC button to access the control panel setup menus. These menus allow adjusting the time clock and other parameters that affect the control panel operation.



MAIN
TIMES

From this screen, press ESC again to access the internal menus. ENTER will return to the main screen (HOME).



DISPLAY ALARMS
OPERATOR MENU

Once at this screen, use ▲, ▼ and ENTER to navigate through these menus. (ESC will return to the previous menu.)

Use the OPERATOR MENU to set the control panel clock and the display language (English or Spanish).

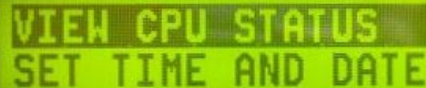

VIEW CPU STATUS
SET TIME AND DATE



SET TIME AND DATE
SELECT LANGUAGE

Communication parameters are set in the DIAGNOSTIC MENU, with respect to the PLC. If the PLC of the control panel is changed, the settings need to agree in order for them to communicate.



OPERATOR MENU
DIAGNOSTIC MENU

Press ENTER to go to the DIAGNOSTIC MENU, then ENTER again at TD 200 SETUP.



TD 200 SETUP
VIEW MESSAGES

Press ▼, then ENTER to access the BAUD RATE section.



The BAUD Rate should be 187K, for communications with the PLC.



NOTICE!

If a new control panel is being installed, the default BAUD RATE may not match and will need to be set. The keypad layout is 'soft', so the keys on the new control panel are not in the same locations as shown on page 20. Use the keypad overlay that comes with the replacement control panel to assist in the setup. Once communication is established with the PLC, the keypad will match the proper key locations.

Network Connections

Be sure to set the compressor ID (page 23) for each compressor in the network before connecting the compressors with a network cable.

Next, verify the time and date settings. If they need to be changed, follow the instructions on page 24. If operating in a network, the time and date must be set on each compressor. Time and date are only used to date stamp errors for the shutdown logs.

NOTICE!

If power is removed from the PLC for more than 120 days, verify the time and date settings, and reset if lost. No other data will be lost due to periods of inactivity, as they are stored in EEPROM.

Once each compressor in the network has been configured, the PROFIBUS cable may be connected. The maximum recommended cable length is 150 feet. That distance may be extended only if the compressor's PLC's are 'bonded' with an eqi-potential wire in addition to the networking cable (the 'M' terminals of the PLC's should be connected to balance the DC connections).

Greater lengths may be connected using isolated repeaters. Network connection can be extended up to 3000' with their use.

All network parameters should be entered through the 'A' compressor. This will be the main 'master'. For communications, the PLC's take the 'master' position briefly to send data to the others, then relinquish the network, giving the appearance of a multi-master system.

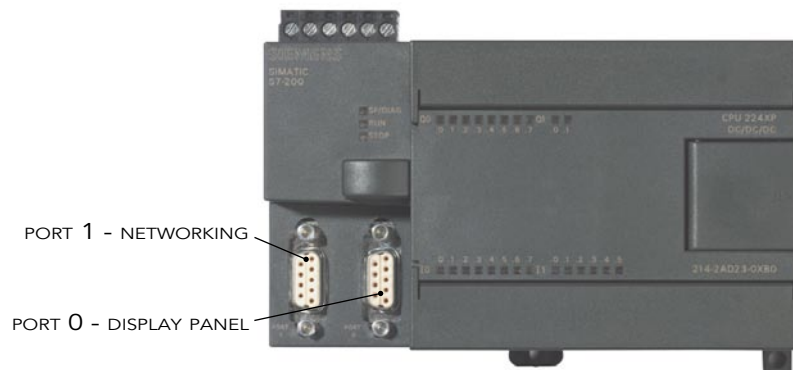

Section V - Servicing

- Preparing for Maintenance or Service
- Safety
- Maintenance Schedule
- Water Removal
- Air/Fluid Separator Element
- Air Filter
- Changing the Compressor Fluid
- Shaft Seal
- Differential Pilot Valve
- Pressure Setting
- Electronic Control
- Air and Fluid Tubing
- O-ring Fittings

Preparing for Maintenance or Service

The following procedure should be followed for maximum safety when preparing for maintenance or service:

- 1) Disconnect and lockout the main power switch and hang a sign at the switch of the unit being serviced.
- 2) Close shutoff valve (block valve) between receiver and plant air system to prevent any backup of air flow into the area to be serviced. NEVER depend upon a check valve to isolate the system.
- 3) Open the manual vent valve and wait for the pressure in the system to be completely relieved before starting service. DO NOT close the manual vent valve at any time while servicing.



WARNING!

Never assume the compressor is ready for maintenance or service because it is stopped. The automatic dual control may start the compressor at any time. Death or serious injury could result.

Safety



NOTICE!

Maintenance should be performed by trained and qualified technicians only.

Safety procedures while servicing the compressor are important to both the service personnel and to those who may be around the compressor and the system it serves. Listed below are some, but not all, procedures that should be followed:

- ◆ Wait for the unit to cool before starting service. Temperatures may exceed 200°F when the compressor is operating.
- ◆ Clean up fluid spills immediately to prevent slipping.
- ◆ Loosen, but do not remove, flange or component bolts. Carefully pry apart to be sure there is no residual pressure before removing bolts.
- ◆ Never use a flammable solvent such as gasoline or kerosene for cleaning air filters or compressor parts.
- ◆ Safety solvents are available and should be used in accordance with their instructions.



CAUTION!

Unusual noise or vibration indicates a problem. Do not operate the compressor until the source has been identified and corrected.

Maintenance Schedule

This Schedule is intended to be used as a guideline only. Depending on the specific operating conditions of your QGD compressor, maintenance requirements may vary. The instructions in this section will give more details about determining when specific service should be performed.

PERIODICALLY/DAILY (8 HOURS MAXIMUM):	MONITOR ALL GAUGES AND INDICATORS FOR NORMAL OPERATION. CHECK FLUID LEVEL. DRAIN WATER FROM AIR/FLUID RESERVOIR. OBSERVE FOR FLUID LEAKS. OBSERVE FOR UNUSUAL NOISE OR VIBRATION.
MONTHLY:	REPLACE AIR FILTER. (DAILY OR WEEKLY SERVICE MAY BE REQUIRED UNDER CERTAIN CONDITIONS.) CLEAN FLUID COOLER FINS (AIR-COOLED). WIPE DOWN ENTIRE UNIT TO MAINTAIN APPEARANCE.
EVERY 6 MONTHS OR 1000 RUNNING HOURS:	TAKE FLUID SAMPLE. REPLACE FLUID FILTER. INSPECT CONTROL LINE FILTER(S) AND REPAIR AS NEEDED.
PERIODICALLY/YEARLY:	REPLACE AIR/FLUID SEPARATOR. CHECK ALL BOLTS FOR TIGHTNESS. LUBRICATE MOTORS. CHECK SAFETY (HAT) SHUTDOWN SYSTEM. TEST PRESSURE RELIEF VALVE FOR PROPER OPERATION. CONTACT A QUALIFIED SERVICEMAN.
EVERY 8000 RUNNING HOURS (OR AS INDICATED BY FLUID ANALYSIS):	REPLACE FLUID.



Unusual noise or vibration indicates a problem. Shutdown the compressor and do not restart until the source has been identified and corrected.

NOTICE!

Reference pages 28 thru 33 for more specific instructions on performing general maintenance. Reference Section VII - Compressor Fluids for instructions regarding taking fluid samples and selecting an appropriate fluid for your machine.

NOTICE!

Failure to follow these maintenance and service recommendations may adversely affect your warranty. Maintain accurate and complete maintenance records to ensure warranty compliance.

Section V - Servicing

Water Removal

Water vapor may condense in the reservoir and must be removed. The frequency with which water must be removed is determined by the ambient air conditions. During hot and humid conditions, water should be drained off the bottom of the reservoir daily. In cold and dry conditions, water may only need to be drained weekly. To drain water from the reservoir, turn the compressor off and let sit for at least 5 minutes. Then open the drain valve.

Water is heavier than the compressor fluid and will collect at the bottom of the reservoir. When the drain is first opened some compressor fluid may come out before the water starts to flow. Close the valve when the water flow changes to compressor fluid. Make certain that there is no pressure in the reservoir before opening the drain valve. Water content in the compressor fluid in excess of 200 PPM could cause bearing damage and air end failure.

Air/Fluid Separator

The air/fluid separator is a spin on, full flow unit. Replacement requires spinning off the cartridge and replacing it with a new one.

The air/fluid separator should be replaced as indicated in the maintenance schedule or as follows:

- ◆ If excessive fluid carryover is observed.
- ◆ 4000 hours maximum or as indicated by differential pressure indicator.
- ◆ As indicated by the gauge (if equipped).

Air Filter

The standard QGD™ air filter is a single stage, dry type element attached to the inlet valve. The filter media is pleated and will stop particles of 10 microns in size. This element is replaceable and should not be cleaned. Service intervals of the air filter element depends on ambient conditions and should be established by checking regular intervals until a pattern for servicing is found. Daily maintenance of the filter element is not uncommon in dirty conditions. If dirty conditions exist, it is advisable to relocate the intake air to an outside source. Each time the filter is serviced, inspect the filtered air side of the air cleaner canister and the suction manifold for dirt. If dirt is found, determine the cause and correct. Always make

sure all gaskets, threaded connections, flange connections, and hose connections between the air filter and air compressor are airtight. Dirty filters result in reduced airflow and can distort the element and allow dirt to bypass the filter element.

NOTICE!

Intake filtration equipment supplied from the factory may not be adequate for extremely dirty applications or some forms of dust or vapors. It is the customer's responsibility to provide adequate filtration for those conditions. Warranty will be voided if inadequate filtration causes a failure.

Changing the Compressor Fluid

QGD series compressors utilize a pressurized fluid drain. Use the following procedure to drain and replace the compressor fluid.

- ◆ Press the emergency stop button and remove the right side cabinet panel (if applicable).
- ◆ Check the pressure on the pressure reservoir pressure gauge and wait until the pressure in the reservoir tank drops to approximately 40 psig.

- ◆ Close the 1/4 turn valve on the blowdown valve.
- ◆ Remove the drain plug and attach the 1/4" NPT barb fitting and drain tube (supplied with the unit) to the drain on the reservoir.



- ◆ Slowly open the 1/4 turn valve on the reservoir drain. The pressure remaining in the tank will force the fluid out. When air begins to escape from the tank, close the valve.

- ◆ After closing the valve, remove the tubing and barb fitting and reinstall the drain plug.
- ◆ Remove the plug from the fluid fill port and refill the reservoir with the appropriate amount and type of fluid.

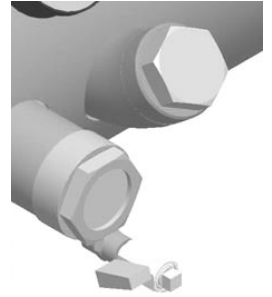

NOTICE!

Reference section VI for more information regarding compressor fluids.

- ◆ Open the 1/4 turn valve on the blowdown valve and restart the compressor.

NOTICE!

The 1/4 turn valve on the blowdown valve **MUST** be open for the unit to blowdown during regular unit operation.

Section V - Servicing

Shaft Seal

Compressor shaft seals are wear items that may eventually have to be replaced. Special tools and a complete understanding of the installation procedure are required for a successful seal replacement. Ask your Quincy distributor for complete illustrated instructions (available as a Service Alert) at the time you order the seal and special tools, if you decide to replace the seal yourself. If your distributor does not have a copy of these instructions, they can be ordered from Quincy Compressor® at no charge.

QGD™ compressors incorporate a fluid scavenge system to complement the use of a triple lip seal assembly. Any complaint of shaft seal leakage requires that the scavenge system be inspected for proper operation prior to the replacement of the shaft seal. Proper inspection consists of the following:

- ◆ Assure that the scavenge line itself is not plugged.
- ◆ Inspect the performance of the scavenge line check valve by removing the fitting located at the bottom of the motor adapter. Remove the check ball and inspect for wear. If the check valve is stuck open, fluid can backflush from the airend into the seal cavity and appear as a leak. If the check valve is stuck closed the seal cavity will not scavenge. Replace if necessary.
- ◆ Remove the four bolts securing the seal adapter to the suction housing.
- ◆ Insert two of the seal adapter retaining bolts into the seal adapter jack holes and turn clockwise (pushing the seal adapter away from the suction housing).

- ◆ After the seal adapter outer o-ring has cleared the seal adapter bore, remove the adapter for inspection.
- ◆ Disassemble the seal adapter as follows:
 - a. With the face of the seal adapter up, insert two small, flat screwdrivers under the outer lip of the fluid slinger and pop the slinger from the seal adapter bore.
 - b. Using a brass drift, tap the shaft seal assembly from the seal bore.
 - c. Inspect both seal lips for excessive wear, lip flaws or damage.
 - d. Inspect the outer o-ring on the fluid slinger for cuts or nicks.
 - e. Inspect the outer o-ring on the seal adapter for cuts and nicks.
 - f. Slide the wear sleeve removal tool over the end of the shaft and allow the jaws of the tool to snap on the backside of the wear sleeve. Tighten the outer shell of the tool down over the inner jaws.
 - g. Using a ratchet and socket, turn the puller jack screw clockwise in against the end of the compressor shaft to remove the seal wear sleeve.



CAUTION!

Do Not use an impact wrench with this tool.

Preparation for New Seal Installation

- ◆ Inspect the compressor shaft for burrs or deep scratches at the wear sleeve area. Using a 100 grit emery cloth, lightly sand horizontally any rust or Loctite™ on the shaft. Using a fine file or emery cloth, deburr the key area of the rotor shaft. Cover the keyway with masking tape to prevent damage to the new seal during installation.
- ◆ Clean the seal adapter with fast drying solvent. Assure that the scavenge drain in the seal adapter is clean and open. Place the outer face of the seal adapter on a flat, hard surface.
- ◆ Remove the new triple lip seal from the package and inspect for damage or imperfections on the seal lips.
- ◆ Apply a thin coat of Loctite™ 290 to the outer steel case of the seal and position the seal in the seal adapter bore.
- ◆ Insert the proper seal driver over the seal. Insert the proper wear sleeve driver in the seal driver and tap the new seal into the bore with a medium sized hammer.
- ◆ Preheat the wear sleeve (in a small oven) to 350°F. **Do not preheat in warm oil.**
- ◆ Apply a thin film of Loctite™ to the inner diameter of the wear sleeve and immediately install on the compressor shaft using the proper wear sleeve driver. Drive the wear sleeve on the shaft until the driver bottoms on the shaft shoulder.

Seal Installation

- ◆ Apply a thin coat of compressor fluid to the outer face of the wear sleeve and seal lip.
- ◆ Slide the proper seal installation sleeve against the wear sleeve with the taper toward the end of the rotor shaft.
- ◆ Install a new o-ring on the seal adapter and lubricate with compressor fluid.
- ◆ Install a new o-ring around the scavenge port (use petroleum jelly to hold the o-ring on the seal adapter face during installation).
- ◆ Carefully slide the seal adapter with the new seal installed over the end of the rotor shaft and up against the adapter bore.
- ◆ Using care not to damage the o-ring, evenly draw the adapter into the bore, install the four retaining bolts and tighten to the specified torque.
- ◆ Remove the installation sleeve.
- ◆ Apply a thin film of compressor fluid to the o-ring and seal lip of the outer fluid slinger.
- ◆ Install the outer slinger over the end of the rotor shaft and push into the scavenge bore using both thumbs.

Section V - Servicing

Differential Pilot Valve



WARNING!

Never adjust the pressure higher than the factory setting. Death or serious injury and compressor or property damage could result.

Open a manual vent valve to allow the compressor to exhaust air to the outside and start the unit. By manual regulation, slowly close the valve, allowing the unit to build air pressure to the desired modulation point and hold (100 PSIG standard). Adjust the screw on the bottom of the differential pilot valve so that a slight stream of air can be felt coming from the orifice adjacent to the adjustment screw.

When the air is felt, air is beginning to pass through the pilot valve to the air cylinder

on the inlet valve, causing the valve to modulate toward its closed position, thereby reducing the volume of air being compressed.

To raise the pressure, turn the adjusting screw in (clockwise). To lower the pressure, turn the screw out (counter clockwise).

Maximum full load pressure is 125 PSIG for standard QGD™ units. Minimum full load pressure with modulation and standard controls is 100 PSIG.



NOTICE!

Although temporary operation pressure can be as low as 75 psig, continuous operation below 100 psig will cause an increase in fluid carryover.

Pressure Setting

The pressure setting determines what pressure the compressor will load and unload. Standard factory settings are listed in the QGD Specifications. If a lower setting is desired, adjust the differential pilot valve first and set the pressure cut-out point to 15 PSIG over the desired full load pressure. Refer to HMI Control Panel

Operation in Section IV for instructions on adjusting the pressure settings. The pressure settings should unload the compressor by the time it reaches the 20% load point. Raising the pressure without changing the compressor speed above factory settings will result in high amp draw and drive belt failures. Consult your parts book for proper sheave and belt part numbers.

Electronic Control

Prior to attempting any repairs of the electronic control or related components, disconnect and lock out all power supplies to the compressor plus any remote controllers. Assure yourself that power is removed from the compressor by checking for any AC voltage at the line side of the motor starter.

Replacing the HAT or Transducer

To replace the temperature switch (HAT probe), remove the probe from the reservoir. Install a new probe into the reservoir. Connect the wires of the new probe to the existing wires. Perform HAT tests to assure that the system functions correctly.

To replace the pressure transducer: The pressure transducer is located at the minimum pressure check valve. Remove the connector at the back of the transducer, replace the transducer and reinstall the connector.

Replacing Electronic Control

Prior to replacing electronic control, gather and record information regarding total running hours, separator hours, air filter hours, fluid filter hours and fluid service/sample hours.

To replace the electronic control, remove the screws attaching control to the panel. Remove and discard wire tie-wraps.

NOTICE!

Prior to removing any wiring from the electronic control, identify individual wire location. Refer to the electrical wiring diagram.

Install new electronic control panel and install wiring in accordance with electrical wiring diagram. Attach to the panel using existing hardware. Install new wire tie-wraps to secure wiring to wire bundle.

Operational Test

Remove tag and lock out tools. Restore power to unit. If electronic control was replaced, refer to the Program Setup Menu to program the replacement electronic control. Once completed, perform an operational test to assure unit is operating correctly.

Air and Fluid Tubing

Flareless tubing is used in the air piping to eliminate pipe joints and provide a cleaner appearance. Replacement tubing and fittings are available; however, special installation procedures must be followed. Your authorized distributor has the necessary instructions and experience to perform these repairs.



WARNING!

Failure to install flareless tubing or fittings correctly may result in the tubing coming apart under pressure. Serious injury and property damage may result.

Section V - Servicing

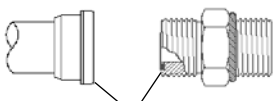
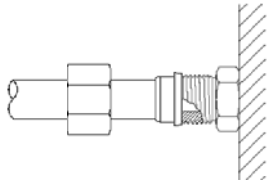
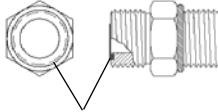
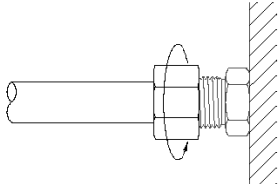
ASSEMBLING THE FACE SEAL END	
<p>1) CHECK SEALING SURFACES</p>  <p>CHECK SEALING SURFACE AND GROOVE FOR DAMAGE OR MATERIAL BUILDUP.</p>	<p>3) POSITION TO FITTING</p>  <p>ENSURE THAT O-RING IS PROPERLY SEATED IN THE GROOVE.</p> <p>POSITION AND HOLD FLAT SEALING FACE AGAINST O-RING.</p>
<p>2) INSTALL O-RING</p>  <p>CORRECTLY SIZED O-RING IS 0.070" THICK AND ITS O. D. TOUCHES THE OUTSIDE EDGE OF THE GROOVE.</p>	<p>4) THREAD ON NUT BY HAND & 5) WRENCH TIGHTEN</p>  <p>IF PROPERLY ALIGNED, THE NUT SHOULD THREAD ON EASILY BY HAND.</p> <p>WRENCH TIGHTEN TO RECOMMENDED TORQUE FOR FACE SEAL END.</p>

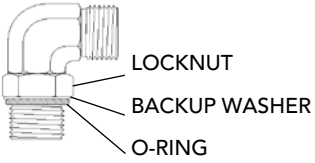
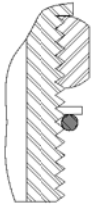
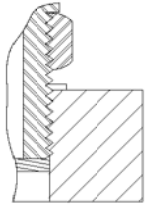
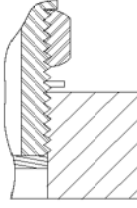
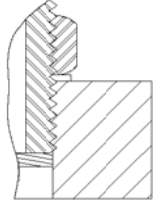
ASSEMBLING ADJUSTABLE END TO PORT			
<p>1) CHECK SEALING SURFACES & INSTALL O-RING</p>  <ul style="list-style-type: none"> • INSPECT FITTING FOR DAMAGE • USE O-RING INSTALLATION TOOL TO INSTALL O-RING • APPLY SMALL AMOUNT OF LUBRICANT TO O-RING 			
<p>2) BACK OFF NUT</p>  <p>BACK OFF LOCKNUT TO ITS UPPERMOST POSITION</p>	<p>3) THREAD INTO PORT</p>  <p>THREAD FITTING INTO THE PORT UNTIL THE BACKUP WASHER CONTACTS THE SURFACE</p>	<p>4) BACK OFF FOR ALIGNMENT</p>  <p>POSITION FITTING FOR ATTACHING LINE BY UN-THREADING UP TO 360°</p>	<p>5) WRENCH TIGHTEN</p>  <p>WRENCH TIGHTEN LOCKNUT</p>

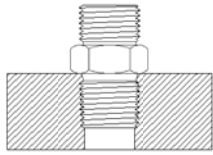
ASSEMBLING NON-ADJUSTABLE PORT END	
	<ul style="list-style-type: none"> • INSPECT SEALING SURFACES FOR DAMAGE • INSTALL O-RING • THREAD FITTING INTO PORT AND WRENCH TIGHTEN

SEAL-LOK ASSEMBLY TORQUES (IN LBS)								
DASH SIZE	4	6	8	10	12	16	20	24
FACE SEAL	220	320	480	750	1080	1440	1680	1980
END	(+/-) 10	(+/-) 25	(+/-) 25	(+/-) 35	(+/-) 45	(+/-) 90	(+/-) 90	(+/-) 100

Section VI - Compressor Fluids

- Fluid Specifications
- Lubrication
- Fluid Level
- Fluid Filter
- Factors Affecting Fluid Life
- Fluid Analysis Program - General
- QuinSyn Plus
- QuinSyn PG
- QuinSyn XP
- QuinSyn Fluids
- QuinSyn Flush
- Cleaning and Flushing With QuinSyn Flush
- Converting to QuinSyn PG
- Converting to QuinSyn XP
- Converting to QuinSyn Plus
- Sampling Procedures
- Understanding the Analysis Report
- Fluid Parameters

The three functions of compressor fluid are:

- ◆ • to lubricate the bearings and rotors
- ◆ • to remove heat from the air as it is being compressed thus lowering the compressed air discharge temperature
- ◆ • to seal the rotor clearances

Fluid Specifications

We recommend that all Quincy rotary screw compressors be filled with one of the following synthetic fluids:

- QuinSyn PG** - Standard fill.
- QuinSyn XP** - Standard fill for high pressure applications.
- QuinSyn Plus** - Extended life fluid.
- QuinSyn F** - Food grade applications.
- QuinSyn IV** - 4000 hour alternative fluid.

A fluid tag is attached to each Quincy rotary screw compressor indicating the type of fluid provided in the initial fill. All of the above fluids are available from any authorized Quincy distributor.



CAUTION!

Do not mix different grades or types of fluid. Do not use inferior grades of fluids.



NOTICE!

Failure to follow these fluid recommendations will adversely affect your warranty.

Lubrication

QGD model air compressors use pressure differential to circulate the fluid. Positive pressure maintained in the reservoir forces the fluid throughout the machine.

Each Quincy compressor is filled at the factory with the correct amount of one of the synthetic fluid listed in the Fluid Specifications. Mineral oil

can be requested and used in specific applications. The use of other brands or types of fluid may reduce the design life of the compressor or cause problems with filtration or carryover. Consult the Quincy Service Department before changing brands of fluid.

Fluid Level

Fluid level is monitored by a sightglass while in operation. Fluid level should completely fill the sight gauge. **DO NOT OVERFILL.**

Each unit comes equipped with a fluid level sight gauge, fluid fill opening, and a fluid drain in the reservoir. The fill plug is drilled to allow some pressure to escape before the plug is completely removed. Should you hear pressurized air venting through the hole, immediately screw the plug back into the reservoir. Relieve the pressure in the machine before proceeding.



CAUTION!

Hot fluid under pressure could cause death or serious injury. Do not remove the fluid fill plug and attempt to add fluid to the reservoir while the compressor is in operation or when the system is under pressure. Be sure that the compressor's red mushroom stop button is pushed in and locked and that the main power disconnect switch is in the off position and locked out to assure that the compressor will not start automatically.

Section VI - Compressor Fluids

Fluid Filter

The fluid filter is a spin on, full flow unit. Replacement of the filter requires spinning off the cartridge and replacing it with a new one.

NOTICE!

Use genuine Quincy replacement filters only.



The initial filter change should occur after the first 500 hours of operation. During normal service, the filter cartridge should be replaced under the following conditions, **whichever occurs first**:

- ◆ • as indicated by the fluid filter maintenance indicator when the fluid is at normal operating temperature
- ◆ • every 1,000 hours
- ◆ • every fluid change

NOTICE!

The fluid filter maintenance indicator may read high upon start up on cool mornings due to sluggish fluid creating higher than normal differential pressures. Monitor indicator after the fluid warms up.

Factors Affecting Fluid Life

To protect your investment, check for the following, which can affect the long life of QuinSyn:

- 1) High operating temperatures
- 2) Contaminants:
 - a. Other fluids
 - b. Strong Oxidizers such as:
 - acids
 - sulfur
 - chlorine
 - burnt fuel -
i.e. exhaust from: forklifts, boilers, jet aircraft
 - nitrogen oxides
 - ozone
 - welding fumes
 - plastic molding fumes
 - c. Ammonia
 - d. Solvent fumes:
 - chlorinated degreasers
 - ink solvents
 - e. Airborne dust and particles
 - f. Paper digester fumes

Locate your compressor in the coolest area possible. For every 18°F above 195°F, the operating life of any fluid is reduced to about half that at 195°F. Some mineral oils begin to form varnish at temperatures above 200°F. QuinSyn fluids are more forgiving than mineral oil at high temperatures. QuinSyn XP is designed to operate at sustained temperatures above 200°F. The life of other QuinSyn fluids will be shortened at high temperatures.

Air intake should provide contaminant-free, cool air. A Quincy heavy-duty intake filter will reduce the risk of abrasion and increased wear. An air filter does not eliminate reactive gases. Inspect your filter monthly and replace as required.

Fluid Analysis Program - General

Quincy's fluid analysis program is offered to all customers using QuinSyn fluids in Quincy Compressor® Rotary Screw Compressors. This service provides optimum drain intervals for compressors operating on QuinSyn fluids. Monitoring of the total acid number (TAN), barium level and/or viscosity throughout the life of the fluid provides maximum protection to your machine, while best utilizing the extended life features of QuinSyn.

The fluid analysis provides historical information, detailing items such as hours on the fluid, viscosity and total acid number (TAN). Should results appear unusual or suspicious, a detailed analysis can pinpoint specific contaminants. A detailed report is furnished to you, your Quincy Distributor and the Quincy Compressor® factory upon completion of the fluid analysis.

Although QuinSyn fluids are rated by hours of life expectancy under normal operating conditions, it is recommended that fluid samples be taken every 500 to 2000 hours

and sent to Quincy Compressor® Fluid Analysis until a history of performance in a specific compressor application is established. Once the appropriate drain interval is established, the frequency of the fluid analysis can be reduced unless operating conditions change.

NOTICE!

All Quincy Compressor® extended airend warranty programs require that fluid samples be sent to Quincy Compressor® Fluid Analysis a minimum of every 2,000 hours.

The depletion of antioxidants, change of viscosity, barium and acid levels all occur with time. It is extremely important to change QuinSyn before the antioxidants are completely depleted. If the fluid is left in the compressor beyond its useful life, removing all of the spent fluid is difficult. The oxidation products remaining can considerably shorten the life of the new fill of QuinSyn fluid.

Section VI - Compressor Fluids

QuinSyn Plus

QuinSyn Plus is the factory fill for Quincy rotary screw compressors.

QuinSyn Plus is an ISO 46 viscosity fluid with an 8,000 hour life under normal operating conditions (exact fluid life is determined by the fluid analysis program). It is a synthetic hydrocarbon/ester fluid.

QuinSyn Plus is totally compatible with QuinSyn. Machines currently running with QuinSyn fluid can be topped off with QuinSyn Plus with no adverse effects.

Some advantages of QuinSyn plus are:

- Superior demulsability (ability to separate from water)
- Less susceptible to varnish
- Extremely low volatility
- Excellent corrosion protection
- Outstanding low temperature properties
- Exceptional thermal stability
- Excellent oxidative stability
- Better gas-fluid separation

Typical Properties of QuinSyn Plus ISO 46

Viscosity @ 100°F ASTM D445	46.0 cSt.
Viscosity @ 210°F ASTM D445	7.5 cSt.
Viscosity Index ASTM D2270	127
Specific Gravity 60/60	0.89
Flash Point ASTM D92	475°F
Fire Point ASTM D92	540°F
Pour Point	-58°F

Applications

QuinSyn Plus is suited for use in rotary screw air compressors operating in harsh service conditions where the fluid is exposed to higher temperatures for extended periods of time. Fluid thermostat temperature settings can be elevated to assist in reducing water content in the fluid in high humidity applications. Please consult Quincy Service Department for any thermostat changes.

Disposal

QuinSyn Plus is considered nonhazardous waste. Disposal of this fluid should be done in accordance with Local, State, and Federal regulations. Should condensate need to be treated, Quincy's QIOWA fluid/water separators are required.

Fluid Analysis Program

QuinSyn Plus fluid is included in Quincy's fluid analysis program.

NOTICE!

To maintain extended warranty compliance, fluid samples of QuinSyn Plus must be sent to Quincy Compressor® Fluid Analysis a minimum of every 2,000 hours.

QuinSyn PG

QuinSyn PG is a custom blended polyalkylene glycol/ester (PAG). QuinSyn PG is an ISO 46 viscosity fluid with an 8,000 hour life under normal operating conditions (exact fluid life is determined by the fluid analysis program). Under extended warranty conditions QuinSyn PG fluid life is rated at 8,000 hours or one year, whichever occurs first.

<u>Typical Properties of QuinSyn PG</u>	<u>ISO 46</u>
Viscosity @ 100°F ASTM D445	52.4 cSt.
Viscosity @ 210°F ASTM D445	9.4 cSt.
Viscosity Index ASTM D2270	163
Specific Gravity 60/60	0.98
Flash Point ASTM D92	485°F
Fire Point ASTM D92	525°F

Applications

QuinSyn PG is the recommended fluid in high humidity applications due to its ability to hold water. QuinSyn PG is best suited for applications where high humidity exists and the machine cannot be shut down to drain water from the reservoir.

Disposal

QuinSyn PG is considered nonhazardous waste. Disposal of this fluid should be done in accordance with Local, State, and Federal regulations. Separation of

this fluid from condensate will require those separators designed to handle fluid emulsions. The QCS fluid/water separator is suitable for separation of fluid emulsions such as QuinSyn PG. Please contact Quincy's Service Department for more details.

Fluid Analysis Program

The fluid sampling for QuinSyn PG has been extended to 2,000 hours because of the superior quality and forgiving nature of this fluid. The new five-year extended warranty with QuinSyn PG requires 2,000 hour sampling as a condition of maintaining the warranty.

NOTICE!

To maintain warranty compliance, fluid samples of QuinSyn PG must be sent to Quincy Compressor® Fluid Analysis a minimum of every 2,000 hours.

Primary concerns with this fluid are the total acid number (TAN) and barium levels. QuinSyn PG will not be condemned on water percentage nor antioxidants but will be condemned on low barium and high TAN values. The barium in the fluid acts as a corrosion inhibitor, therefore we have set low limits for this additive (see page 48 for limits).

Section VI - Compressor Fluids

QuinSyn XP

QuinSyn XP is the factory fill for high pressure units (defined as units over 125 psig full flow). QuinSyn XP replaces QuinSyn HP 68 as our high pressure fluid and is totally compatible with QuinSyn HP 68 (the fluids can be mixed together with absolutely no problems). Aftermarket pail and drum orders for QuinSyn HP 68 will be filled with QuinSyn XP.

QuinSyn XP is a custom blended polyolester (POE) fluid ideally suited for rotary screw air compressors. QuinSyn XP is an ISO 68 viscosity fluid with a 12,000 hour life at 100 & 125 psig full flow under normal operating conditions and 8,000 hours as a high pressure fluid (exact fluid life is determined by the fluid sampling program).

<u>Typical Properties of QuinSyn XP</u>	<u>ISO 68</u>
Viscosity @ 100°F ASTM D445	60.0 cSt.
Viscosity @ 210°F ASTM D445	9.8 cSt.
Viscosity Index ASTM D2270	131
Specific Gravity 60/60	0.95
Flash Point ASTM D92	570°F
Fire Point ASTM D92	645°F

Applications

QuinSyn XP is designed for applications where the fluid is exposed to elevated

temperatures for extended periods of time. Fluid thermostat temperature settings can be elevated to assist in reducing water content in the fluid in high humidity applications. Consult Quincy's Service Department before making thermostat changes.

Disposal

QuinSyn XP is considered nonhazardous waste. Disposal of this fluid should be done in accordance with Local, State, and Federal regulations. Should condensate need to be treated, Quincy's QIOWA fluid/water separators are required.

Fluid Analysis Program

QuinSyn XP will be analyzed similar to QuinSyn although the primary concern is the total acid number (TAN). Supplemental "on site" TAN kits will be applicable to this fluid as well as QuinSyn PG.

NOTICE!

To maintain extended warranty compliance, fluid samples of QuinSyn XP must be sent to Quincy Compressor® Fluid Analysis a minimum of every 2,000 hours.

QuinSyn F

QuinSyn F is Quincy's food grade fluid, suitable in applications where there may be incidental food contact. Compliant with FDA 21 CFR 178.3570 (Lubricants With Incidental Food Contact), QuinSyn F is authorized by the USDA with an H-1 rating for use in federally inspected meat and poultry plants. Since the fluid is viewed as a possible indirect food additive, the limit for food contact is 10 ppm. Near white in color and low in volatility, QuinSyn F is ideal for clean service. A five-year extended warranty is available with the use of QuinSyn F.

Typical Properties of QuinSyn F

Viscosity @ 100°F ASTM D445	43.0 cSt.
Viscosity @ 210°F ASTM D445	7.5 cSt.
Viscosity Index ASTM D2270	139
Flash Point ASTM D92	495°F
Fire Point ASTM D92	560°F
Pour Point	-76°F
Specific Gravity 60/60	0.83
Color*	Water white/White

*Changes to color will occur during operation.

Disposal

QuinSyn F is considered nonhazardous under the OSHA Hazard Communication Standard 21 CFR 1910.1200. They carry no hazardous labels or warnings under that standard.

QuinSyn Flush

QuinSyn Flush is a specially formulated synthetic fluid capable of dissolving varnish and solubilizing sludge from lubricating systems while they are operating. QuinSyn Flush contains oxidation and rust inhibitors, and can be used as a short-term fluid (for a maximum of 500 hours). It is fully compatible with mineral oils and QuinSyn synthetic fluids, and is highly recommended for use as a flushing fluid when converting to QuinSyn PG from QuinSyn Plus or QuinSyn XP.

Applications

Cleaning fluid for removal of varnish, dirt and oxidized fluid from compressor fluid systems.

Flushing fluid when changing from other fluids to QuinSyn fluids.

Typical Properties of QuinSyn Flush

Viscosity @ 100°F ASTM D445	43.3 cSt.
Viscosity @ 210°F ASTM D445	5.6 cSt.
Viscosity Index	65
Flash Point ASTM D92	444°F
Fire Point ASTM D92	520°F
Pour Point	-45°F
Specific Gravity 60/60	0.965

Section VI - Compressor Fluids

Cleaning and Flushing With QuinSyn Flush

Normal Machines

Flushing **clean** machines presently using:

A. Mineral Oils -

Drain compressor thoroughly while hot including all the low areas. Shut down and lockout the machine. Detach lines and drain. Inspect machine; if clean, change filters and separator elements and proceed as follows:

Fill with QuinSyn Flush and run machine until it reaches normal operating temperature. Drain and refill with a fresh charge of the QuinSyn fluid selected for your machine. Send a fluid sample to Quincy Compressor® Fluid Analysis at 200 hours.

B. Polyalkylene glycols (PAG) or Silicone -

Drain compressor thoroughly as in (A). Fill machine with QuinSyn Flush and run for 500 hours. Send a fluid sample to Quincy Compressor® Fluid Analysis. Flush may need to be repeated several times. Analysis will determine if further flushes are needed.

Fill with the QuinSyn fluid selected for your machine. Send a fluid sample to Quincy Compressor® Fluid Analysis at 200 hours.

Varnished Machines

Always clean **slightly varnished** machines using mineral oils or PAO fluids with QuinSyn Flush using the following procedure:

Drain thoroughly as in (A) and fill with QuinSyn Flush. Run the machine for 300 hours and take a fluid sample. Send fluid sample to Quincy Compressor® Fluid Analysis to determine if further flushes are needed. Continue compressor operation until results of fluid analysis are reported. Drain or continue operation as advised by fluid analysis.

Always clean **medium to heavily varnished** machines using mineral oils or PAO fluids with QuinSyn Flush using the following procedure:

Drain thoroughly as in (A) and fill with QuinSyn Flush. Run the machine for 300 hours and take a fluid sample. Send fluid sample to Quincy Compressor® Fluid Analysis to determine if further flushes are needed. Run the flush for an additional 300 hours. Drain thoroughly as in (A) and inspect the compressor. If clean, flush with another half charge of QuinSyn Flush and run for 30 minutes. Drain completely. Change filters and separator elements and fill with a fresh charge of the QuinSyn fluid selected for your machine. Send fluid sample to Quincy Compressor® Fluid Analysis at 200 hours.

Extremely varnished machines should not be put back into service until mechanically or chemically cleaned. After proper cleaning, fill with a fresh charge of the QuinSyn fluid selected for your machine. Send fluid sample to Quincy Compressor® Fluid Analysis at 200 hours.

Converting to QuinSyn PG

Normal Machines

Flush **clean** machines presently using QuinSyn Plus or QuinSyn XP before converting them to QuinSyn PG.

Drain compressor thoroughly while hot, including all the low areas, fluid lines and fluid cooler. Fill with QuinSyn Flush and run compressor until it reaches normal operating temperatures. Shut down and lockout the machine. Drain all the QuinSyn Flush and discard in accordance with all local, state and federal disposal regulations. Change the separator and all the filters on the compressor. Refill the reservoir and system with a full charge of QuinSyn PG.

NOTICE!

If all the previous fluid is not removed from the compressor, excessive foam may be visible in the fluid level sightglass. If this occurs, repeat the flushing procedure.

Varnished Machines

Flush **varnished** machines presently using QuinSyn Plus or QuinSyn XP (following the procedures outlined on page 42) before converting them to QuinSyn PG.

Drain compressor thoroughly while hot, including all the low areas, fluid lines and the fluid cooler. Fill with QuinSyn Flush and run for 300 hours. Take a fluid sample and send to Quincy Compressor® Fluid Analysis to determine if further flushing is

needed. Continue operating compressor until the results of fluid analysis are known. Drain or continue to run compressor as advised by the fluid analysis report.

NOTICE!

More than one flush may be required to remove varnish buildup and reduce the TAN to an acceptable level. It may be necessary to change the fluid filter more frequently while the machine is being cleaned.

If advised to refill with another charge of QuinSyn Flush, run compressor until it reaches normal operating temperature. Shut down and lockout the machine. Drain all of the original charge of the QuinSyn Flush and discard in accordance with all local, state and federal disposal regulations. Refill with a fresh charge of QuinSyn Flush and change the fluid filters. Run compressor for 300 hours. Take a fluid sample and send to Quincy Compressor® Fluid Analysis to determine if further flushing is needed. Proceed as instructed by the fluid analysis report.

If advised to drain the QuinSyn Flush, run compressor until it reaches normal operating temperature. Shut down and lockout the machine. Drain the QuinSyn Flush and discard in accordance with all local, state and federal disposal regulations. Change the separator and fluid filters on the compressor and refill with a full charge of the QuinSyn PG.

Section VI - Compressor Fluids

Converting to QuinSyn XP

Normal Machines

- A. Any QuinSyn fluid - No flush required. Drain Compressor thoroughly while hot, including all the low areas, fluid lines and the fluid cooler. Shut down and lockout the machine. Change the separator and all the filters on the compressor. Refill the reservoir and system with a full charge of QuinSyn XP.
- B. Mineral Oils - Drain compressor thoroughly while hot including all the low areas. Shut down and lockout the machine. Detach lines and drain. Inspect machine; if clean, change filters and separator elements. Fill with QuinSyn Flush and run machine until it reaches normal operating temperature. Drain and refill with a fresh charge of new QuinSyn XP. Send a fluid sample to Quincy Compressor® Fluid Analysis at 200 hours.

Varnished Machines

For **slightly to extremely varnished** machines using mineral oils or PAO fluids, flush the compressor with QuinSyn Flush following the procedures outlined on page 42.

Converting to QuinSyn Plus

Normal Machines

- A. Any QuinSyn fluid (**except QuinSyn PG**) - No flush required. Drain Compressor thoroughly while hot, including all the low areas, fluid lines and the fluid cooler. Shut down and lockout the machine. Change the separator and all the filters on the compressor. Refill the reservoir and system with a full charge of QuinSyn Plus.
- B. Mineral Oils and QuinSyn PG - Drain compressor thoroughly while hot including all the low areas. Shut down and lockout the machine. Detach lines and drain. Inspect machine; if clean, change filters and separator elements. Fill with QuinSyn Flush and run machine until it reaches normal operating temperature. Drain and refill with a fresh charge of new QuinSyn Plus. Send a fluid sample to Quincy Compressor® Fluid Analysis at 200 hours.

Varnished Machines

For **slightly to extremely varnished** machines using mineral oils or PAO fluids, flush the compressor with QuinSyn Flush following the procedures outlined on page 42.



Sampling Procedures

Preferred sample location is the fluid filter. If unable to take sample from fluid filter, proceed as follows:

1. Shutdown and lockout compressor.
2. Relieve pressure in reservoir.
3. Remove plug from reservoir drain line.
4. Drain water from reservoir and discard in approved manner.
5. Fill sample bottle with fluid.
6. Close valve and replace plug in drain line.
7. Return compressor to service and check fluid level during operation. Service with fluid as required.

Using fluid filter sample valve, proceed as follows:

1. Open valve, drain 2-4 ounces of fluid from filter and discard in an approved manner.
2. Fill sample bottle.
3. Close valve.

After collecting sample from either of the above methods:

1. Fill out information label completely.*

Be certain to provide all information as to possible hazards related to a given sample. If this situation exists, all information shall be clearly marked on the sample bottle label.

2. Attach Sample Bottle Label to the bottle and put bottle in mailer.
3. Place Shipping Label on the outside of the mailer and send it by UPS.

FROM: _____ Customer Fax # _____
Model No. _____ Serial No. _____
Fluid _____ Sample Date _____
Hours on Fluid _____ Hours on Machine _____
Distributor _____
Sample From <input type="checkbox"/> Reservoir <input type="checkbox"/> Filter

Sample Bottle Label

FROM:
TO:  Quincy Compressor Fluid Analysis 2300 James Savage Road Midland, MI 48642-6535

Shipping Label

Note: A fluid sample valve kit is available from Quincy Compressor. Contact the Service Department and ask for part number 143286.

Section VI - Compressor Fluids



PRODUCT ANALYSIS REPORT

(a)

(b)

Customer	(d)
Comp. Mfr.	(e)
Fluid Type	(f)
Serial Number	(g)
Model Number	(h)
Hrs. on Fluid	(i)
Hrs. on Machine	(j)
Sample Date	(k)
I.D. #	

(c)

Evaluation: (1)

Physical Properties* Results (m)

Water by Karl Fischer (ppm)	Viscosity 40° C (cSt)	TAN Total Acid #	Particle Count								ISO Code	Antioxidant Level
			5 um	10 um	15 um	20 um	25 um	30 um	35 um	40 um		

* Property values, not to be construed as specifications

Spectrochemical Analysis (n)

Sample Date (Fluid Hours)	Values below are in parts per million (ppm)																	
	Silver (Ag)	Alum. (Al)	Chrom (Cr)	Copp. (Cu)	Iron (Fe)	Nickel (Ni)	Lead (Pb)	Tin (Sn)	Titan (Ti)	Vanad (V)	Bari (Ba)	Calc. (Ca)	Mag. (Mg)	Mol. (Mo)	Sod. (Na)	Phos. (P)	Sili. (Si)	Zinc (Zn)

Quincy Compressor Fluid Analysis
 2300 James Savage Road
 Midland, MI 48642-6535

Thank you for this opportunity to provide technical assistance to your company. If you have any questions about this report please contact us at 1-800-637-8628 or fax 1-517-496-2313.

*means this parameter not tested

Accuracy of recommendations is dependant on representative fluid samples and complete correct data on both unit and fluid.

CC List

--

Understanding the Analysis Report

Reference the page 46 for a copy of a blank analysis report.

- a) REPORT DATE - The date that the fluid was analyzed.
- b) REPORT NUMBER - The assigned number to this report.
- c) CUSTOMER ADDRESS - The name and address of person that this report is being mailed to. This information is being taken from the sample bottle as it is received.
- d) CUSTOMER - The owner of the unit that sample came from.
- e) COMPRESSOR MANUFACTURER - Brand of compressor sample taken from.
- f) FLUID TYPE - This should always be one of the fluids listed in the previous section.
- g) SERIAL NUMBER - The unit serial number of the Quincy compressor the fluid sample was taken from.
- h) MODEL NUMBER - The model number of the Quincy compressor that the fluid sample was taken from.
- i) HOURS ON FLUID - These are the actual hours that the QuinSyn fluid has been in the unit since the last fluid change.
- j) HOURS ON MACHINE - This is the total hours on the compressor hourmeter.
- k) SAMPLE DATE - The date that the sample was taken from the compressor.

NOTICE!

Items c) through k) are information provided by the service person supplying the fluid for analysis. Incomplete or incorrect information will affect the report's accuracy.

- l) EVALUATION - This is a brief statement made by the technician performing the actual fluid analysis. This statement addresses the condition of the fluid and filter. This statement will also note any problems that need attention.
- m) PHYSICAL PROPERTIES RESULTS - Particle size is measured in microns. See Fluid Parameters on pages 48-49.
- n) SPECTROCHEMICAL ANALYSIS - See Fluid Parameters on pages 48-49.

Section VI - Compressor Fluids

FLUID PARAMETERS QuinSyn PG, QuinSyn XP & QuinSyn Plus

PROPERTY	UNITS	TEST METHOD	FLUID TYPE	NEW FLUID	MARGINAL	UNACCEPTABLE
VISCOSITY 40°C	cSt	ASTM D-445	QUINSYN PG	45-55	41,61	<41, >61 (1)
			QUINSYN XP	58-75	50, 85	<50, >85 (1)
			QUINSYN PLUS	42-51	38, 56	<38, >56 (1)
ACID No. TAN	MG KOH/GM	ASTM D-947	QUINSYN PG	<0.2	0.7-0.9	>1 (1)
			QUINSYN XP	<0.2	3-4	>4 (1)
			QUINSYN PLUS	<0.2	1.7-1.9	>2.0 (1)
ADDITIVE METALS						
BARIUM	PPM	PLASMA EMISSION	QUINSYN PG	375-550	150	<10 (1)
			QUINSYN XP	0	5-20	>20
			QUINSYN PLUS	0	5-20	>20
CALCIUM	PPM	PLASMA EMISSION	ALL	0	5-20	>20
MAGNESIUM	PPM	PLASMA EMISSION	ALL	0	5-20	>20
MOLYBDENUM	PPM	PLASMA EMISSION	ALL	0	5-20	>20
SODIUM	PPM	PLASMA EMISSION	QUINSYN PG	0	40-50	>100
			QUINSYN XP	0	40-50	>100
			QUINSYN PLUS	0	5-20	>20
PHOSPHORUS	PPM	PLASMA EMISSION	QUINSYN PG	0	5-20	>20
			QUINSYN XP	<50	5-20	0
			QUINSYN PLUS	0	5-20	>20
ZINC	PPM	PLASMA EMISSION	ALL	0	100-200	>200
WEAR METALS						
SILVER	PPM	PLASMA EMISSION	ALL	0	5-10	>10
ALUMINUM	PPM	PLASMA EMISSION	ALL	0	5-10	>10
CHROMIUM	PPM	PLASMA EMISSION	ALL	0	5-10	>10
COPPER	PPM	PLASMA EMISSION	ALL	0	5-10	>10
IRON	PPM	PLASMA EMISSION	ALL	0	5-10	>10
NICKEL	PPM	PLASMA EMISSION	ALL	0	5-10	>10
LEAD	PPM	PLASMA EMISSION	ALL	0	5-10	>10
TIN	PPM	PLASMA EMISSION	ALL	0	5-10	>10
TITANIUM	PPM	PLASMA EMISSION	ALL	0	5-10	>10
VANADIUM	PPM	PLASMA EMISSION	ALL	0	5-10	>10
OTHER						
SILICON	PPM	PLASMA EMISSION	ALL	0	10-15	>15
WATER	PPM	KARL FISHER	QUINSYN PG	<2000	NOT REPORTED	
			QUINSYN XP	<800	NOT REPORTED	
			QUINSYN PLUS	<800	NOT REPORTED	
ANTIOXIDANT	%	HPCL	ALL	95% MIN.	NOT REPORTED	

(1) THE FLUID WILL BE CONDEMNED BASED ON THESE PARAMETERS.

FLUID PARAMETERS

QuinSyn F

PROPERTY	UNITS	TEST METHOD	NEW FLUID	MARGINAL	UNACCEPTABLE
VISCOSITY 40°C	cSt	ASTM D-445	41-51	39, 56	<39, >56 (1)
ACID No. TAN	MG KOH/GM	ASTM D-947	0.2	0.8-0.9	>1 (1)
ADDITIVE METALS					
BARIUM	PPM	PLASMA EMISSION	0	5-20	>20
CALCIUM	PPM	PLASMA EMISSION	0	5-20	>20
MAGNESIUM	PPM	PLASMA EMISSION	0	5-20	>20
MOLYBDENUM	PPM	PLASMA EMISSION	0	5-20	>20
SODIUM	PPM	PLASMA EMISSION	0	5-20	>20
PHOSPHORUS	PPM	PLASMA EMISSION	0	5-20	>20
ZINC	PPM	PLASMA EMISSION	0	100-200	>200
WEAR METALS					
SILVER	PPM	PLASMA EMISSION	0	5-10	>10
ALUMINUM	PPM	PLASMA EMISSION	0	5-10	>10
CHROMIUM	PPM	PLASMA EMISSION	0	5-10	>10
COPPER	PPM	PLASMA EMISSION	0	5-10	>10
IRON	PPM	PLASMA EMISSION	0	5-10	>10
NICKEL	PPM	PLASMA EMISSION	0	5-10	>10
LEAD	PPM	PLASMA EMISSION	0	5-10	>10
TIN	PPM	PLASMA EMISSION	0	5-10	>10
TITANIUM	PPM	PLASMA EMISSION	0	5-10	>10
VANADIUM	PPM	PLASMA EMISSION	0	5-10	>10
OTHER					
SILICON	PPM	PLASMA EMISSION	0	10-15	>15
WATER	PPM	KARL FISHER	<100	200	>200
PARTICLE COUNT	MICRONS	HIAC ROYCO	ISO CODE X/20		
ANTIOXIDANT	%	LIQUID CHROMATOGRAPHY	95	NOT REPORTED	

(1) THE FLUID WILL BE CONDEMNED BASED ON THESE PARAMETERS.

Section VII - Troubleshooting

Failure to Start:

POWER NOT TURNED "ON"	TURN THE POWER "ON" BY CLOSING THE MAIN DISCONNECT SWITCH OR CIRCUIT BREAKER.
BLOWN CONTROL CIRCUIT FUSE	REPLACE FUSE. FIND AND CORRECT CAUSE.
SAFETY CIRCUIT SHUTDOWN RESULTING FROM HIGH DISCHARGE AIR TEMPERATURE	CORRECT THE SITUATION IN ACCORDANCE WITH THE INSTRUCTION IN THE "HIGH DISCHARGE AIR TEMPERATURE" SECTION OF THIS TROUBLESHOOTING GUIDE. RESTART THE COMPRESSOR.
THERMAL OVERLOAD RELAYS TRIPPING	CORRECT THE CAUSE OF THE OVERLOADED CONDITION, RESET OVERLOAD RELAY AND PRESS THE START BUTTON.
LOW VOLTAGE	ASK THE POWER COMPANY TO MAKE A VOLTAGE CHECK AT YOUR ENTRANCE METER, THEN COMPARE THAT READING TO A READING TAKEN AT THE MOTOR TERMINALS. USE THESE TWO READINGS AS A BASIS FOR LOCATING THE SOURCE OF LOW VOLTAGE.
FAULTY START SWITCH	CHECK THE SWITCH FOR MALFUNCTION OR LOOSE CONNECTIONS.
POWER FAILURE	CHECK POWER SUPPLY TO THE UNIT.
LOOSE WIRE CONNECTIONS	CHECK ALL WIRING TERMINALS FOR CONTACT AND TIGHTNESS.
FAULTY CONTROL RELAY	REPLACE THE RELAY.
FAULTY HIGH AIR TEMPERATURE (HAT) SWITCH	CHECK HAT SWITCH. CONTACT A QUALIFIED SERVICE TECHNICIAN FOR REPAIRS.
FAULTY TRANSFORMER	CHECK SECONDARY VOLTAGE ON TRANSFORMER.

Unscheduled Shutdown:

HIGH DISCHARGE AIR TEMPERATURE	CORRECT THE SITUATION IN ACCORDANCE WITH THE INSTRUCTION IN THE "HIGH DISCHARGE AIR TEMPERATURE" SECTION OF THIS TROUBLESHOOTING GUIDE. RESTART THE COMPRESSOR.
THERMAL MOTOR OVERLOAD RELAYS TRIPPING	CORRECT THE CAUSE OF THE MOTOR OVERLOADED CONDITION, RESET THE OVERLOAD RELAY AND PRESS THE RESET BUTTON.
POWER FAILURE	CHECK POWER SUPPLY AND TRANSFORMER FUSES.
LOOSE WIRE CONNECTIONS	CHECK ALL WIRING TERMINALS FOR CONTACT AND TIGHTNESS.
FAULTY HAT SENSORS	CONTACT A QUALIFIED SERVICE TECHNICIAN FOR REPAIRS.
FAULTY CONTROL RELAY	REPLACE RELAY.

Thermal Overload Relays Tripping:

EXCESSIVE DISCHARGE PRESSURE	LOWER FULL LOAD PRESSURE SETTING AT CONTROL PANEL.
LOW VOLTAGE	CHECK VOLTAGE AND AMPERAGES WHILE OPERATING AT FULL LOAD PRESSURE.
LOOSE OVERLOAD CONNECTION	TIGHTEN MOUNTING SCREWS ON THERMAL OVERLOAD.
INCORRECT THERMAL OVERLOAD RELAY SETTING	CHECK MOTOR NAMEPLATE AND COMPARE TO OVERLOAD RELAY SETTING.
LOOSE MOTOR OR STARTER WIRING	CHECK ALL CONNECTIONS FOR TIGHTNESS.
FAULTY MOTOR	CHECK MOTOR STARTER WIRING BEFORE REMOVING MOTOR. REMOVE MOTOR AND HAVE TESTED AT MOTOR MANUFACTURER REPAIR CENTER.

Low Air Delivery:

PLUGGED AIR INTAKE FILTER ELEMENT	CLEAN AIR FILTER ELEMENT OR REPLACE WITH NEW ELEMENT.
EXCESSIVE LEAKS IN THE SERVICE LINES	CHECK SERVICE LINES FOR LEAKS WITH SOAP SUDS. REPAIR AS NECESSARY.
INLET VALVE NOT FULLY OPEN	CHECK FOR BUILD UP OR GUMMING OF SHAFT.
RESTRICTED FLUID FLOW	CHECK FLUID FILTER FOR PLUGGING.

Low Receiver Pressure:

EXCESSIVE AIR DEMAND	REEVALUATE AIR DEMAND. INSTALL ADDITIONAL COMPRESSORS AS NEEDED.
EXCESSIVE LEAKS IN THE SERVICE LINES	CHECK SERVICE LINES FOR LEAKS WITH SOAP SUDS. REPAIR AS NECESSARY.
INLET VALVE NOT FULLY OPEN	CORRECT IN ACCORDANCE WITH THE INSTRUCTIONS IN "INLET VALVE NOT OPENING OR CLOSING IN RELATION TO AIR DEMAND" SECTION OF TROUBLESHOOTING GUIDE.
PLUGGED AIR INTAKE FILTER	REPLACE AIR FILTER ELEMENT.
DIFFERENTIAL PILOT VALVE NOT SET CORRECTLY	ADJUST DIFFERENTIAL PILOT VALVE TO ACHIEVE DESIRED MODULATION RANGE.
AIR PRESSURE SETTING NOT SET CORRECTLY	ADJUST AIR PRESSURE SWITCH TO ACHIEVE DESIRED CUT-IN AND CUT-OUT PRESSURE.
FAULTY RECEIVER PRESSURE GAUGE OR SENSOR	CHECK AND REPLACE AS NECESSARY.

High Receiver Pressure:

AIR PRESSURE SETTING NOT SET CORRECTLY	ADJUST AIR PRESSURE SETTING TO ACHIEVE DESIRED CUT-IN AND CUT-OUT PRESSURE. ENSURE UNLOAD PRESSURE DOES NOT EXCEED MAXIMUM OPERATING PRESSURE.
INLET VALVE NOT CLOSING AT LOWER AIR DEMAND	CORRECT IN ACCORDANCE WITH INSTRUCTION ON "INLET VALVE NOT OPENING OR CLOSING IN RELATION TO AIR DEMAND" SECTION OF THIS TROUBLESHOOTING GUIDE.
BLOWDOWN VALVE NOT RELIEVING RECEIVER PRESSURE	CHECK CONTROL SOLENOID AND BLOWDOWN VALVE.

Section VII - Troubleshooting

High Discharge Air Temperature and/or High Fluid Injection Temperature:

INADEQUATE CIRCULATION OF COOLING AIR AT THE COOLER	CHECK LOCATION OF COOLER AND ASSURE NO RESTRICTION TO FREE CIRCULATION OF COOLING AIR. CHECK COOLER FIN AND CLEAN AS NECESSARY.
LOW FLUID LEVEL IN RESERVOIR	ADD FLUID TO RECOMMENDED LEVEL. CHECK FLUID SYSTEM FOR LEAKS.
CABINET PANELS REMOVED	REPLACE ALL PANELS, ENSURE ALL SEALING SURFACES AND MATERIALS ARE SATISFACTORY.
COOLER PLUGGED	CLEAN COOLER, FIND AND CORRECT CAUSE OF CONTAMINATION.
FLUID FILTER PLUGGED	REPLACE FLUID FILTER ELEMENT(S).
EXCESSIVE AMBIENT TEMPERATURES	MAXIMUM AMBIENT FOR PROPER OPERATION IS LISTED IN DATA SHEET. VENTILATE ROOM OR RELOCATE COMPRESSOR.
INCORRECT FAN ROTATION	CORRECT ROTATION IS WITH THE FAN PUSHING THE AIR THROUGH THE COOLER. REVERSE MOTOR STARTER LEADS L1 AND L2.
IMPROPER FLUID	USE RECOMMENDED FLUIDS ONLY. REFER TO "COMPRESSOR FLUIDS" SECTION OF THIS MANUAL.

High Discharge Air Temperature and/or High Fluid Injection Temperature (continued):

CLOGGED AIR FILTER	CLEAN OR REPLACE AS NECESSARY.
FAULTY THERMAL VALVE	REPAIR OR REPLACE AS NECESSARY.
FAULTY SENSORS	CHECK AND REPLACE AS NECESSARY.
AIREND FAILURE	CONTACT AN AUTHORIZED QUINCY DISTRIBUTOR.

Frequent Air/Fluid Separator Clogging:

FAULTY AIR FILTER OR INADEQUATE FILTER FOR THE ENVIRONMENT	IF FAULTY AIR FILTER ELEMENTS, REPLACE THEM. IF AIR FILTER IS INADEQUATE FOR THE ENVIRONMENT, RELOCATE THE INTAKE AIR TO A CLEAN SOURCE.
FAULTY FLUID FILTER	REPLACE FLUID FILTER ELEMENT.
FLUID BREAKDOWN	CORRECT IN ACCORDANCE WITH THE INSTRUCTION IN "FLUID BREAKDOWN" SECTION OF THE TROUBLESHOOTING GUIDE.
INCORRECT FLUID SEPARATOR ELEMENT	USE GENUINE QUINCY REPLACEMENT ELEMENTS ONLY.
EXTREME OPERATING CONDITIONS SUCH AS HIGH COMPRESSOR DISCHARGE TEMPERATURES, HIGH AMBIENT TEMPERATURE WITH HIGH HUMIDITY AND HIGH RESERVOIR PRESSURE	OPERATE COMPRESSOR AT RECOMMENDED RESERVOIR PRESSURE AND DISCHARGE AIR TEMPERATURE.
MIXING DIFFERENT GRADES OR TYPES OF FLUIDS	DO NOT MIX DIFFERENT GRADES OR TYPES OF FLUID. DO NOT MIX FLUIDS FROM DIFFERENT MANUFACTURERS.
INCORRECT FLUID	FOLLOW FLUID SPECIFICATIONS AS DESCRIBED IN "COMPRESSOR FLUIDS" SECTION OF THIS MANUAL.
CONTAMINATED FLUID	CHANGE FLUID. SERVICE AIR FILTER AND FLUID FILTER IN ACCORDANCE WITH THE RECOMMENDED MAINTENANCE SCHEDULE.

Fluid Discharge Out Blowdown Valve:

TOO HIGH FLUID LEVEL IN RESERVOIR	ADJUST FLUID LEVEL TO RECOMMENDED FLUID LEVEL BY DRAINING THE RESERVOIR. USE FLUID LEVEL GAUGE AS A GUIDE.
AIR/FLUID RESERVOIR BLOWS DOWN TOO FAST	CHECK FOR PROPER BLOWDOWN VALVE SIZE.
INLET VALVE NOT CLOSING COMPLETELY	CORRECT IN ACCORDANCE WITH INSTRUCTIONS IN "INLET VALVE NOT OPENING OR CLOSING IN RELATION TO AIR DEMAND" SECTION OF THIS TROUBLESHOOTING GUIDE

Frequent Fluid Filter Clogging:

FAULTY INDICATOR	REPLACE INDICATOR ASSEMBLY.
INCORRECT FLUID FILTER	USE GENUINE QUINCY REPLACEMENT FILTERS ONLY.
FAULTY, INCORRECT OR INADEQUATE AIR FILTER	REPLACE AIR FILTER ELEMENT.
FLUID BREAKDOWN	SEE FLUID BREAKDOWN SECTION OF THIS TROUBLESHOOTING GUIDE.
SYSTEM CONTAMINATION	CHECK AND CLEAN SYSTEM OF ALL DIRT, CORROSION AND VARNISH.

Excessive Fluid Consumption:

TOO HIGH FLUID LEVEL IN THE RECEIVER	ADJUST FLUID LEVEL TO RECOMMENDED FLUID LEVEL BY DRAINING THE RESERVOIR. USE FLUID LEVEL GAUGE AS A GUIDE.
PLUGGED SCAVENGE LINE	CLEAN SCAVENGER LINE ORIFICE AND TUBE.
HIGH DISCHARGE TEMPERATURE	CORRECT IN ACCORDANCE WITH THE INSTRUCTIONS IN "HIGH DISCHARGE AIR TEMPERATURE" SECTION OF THIS TROUBLESHOOTING GUIDE.
LOW RESERVOIR PRESSURE WITH FULLY OPEN INLET VALVE	RESERVOIR PRESSURE SHOULD NOT FALL BELOW 50 PSIG WHEN RUNNING LOADED. CHECK SYSTEM CFM REQUIREMENT AND MINIMUM PRESSURE CHECK VALVE.
FAULTY OR DAMAGED SEPARATOR	CHANGE AIR/FLUID SEPARATOR.
LEAK IN FLUID LINES	CHECK FOR LEAKS AND CORRECT.
SEAL FAILURE, LEAKS	REPLACE SEAL ASSEMBLY AND O-RINGS.
INCORRECT FLUID	USE RECOMMENDED FLUIDS ONLY. SEE COMPRESSOR FLUID SECTION.

Frequent Air Cleaner Clogging:

COMPRESSOR OPERATING IN HIGHLY CONTAMINATED ATMOSPHERE	USE REMOTE AIR INTAKE MOUNTING.
AIR CLEANER NOT ADEQUATE FOR CONDITIONS	USE SPECIALIZED AIR FILTER. CONTACT AN AUTHORIZED QUINCY DISTRIBUTOR.

Section VII - Troubleshooting

Inlet Valve Not Opening Or Closing In Relation To Air Demand:

IMPROPER PRESSURE SETTING OR FAULTY SENSOR	ADJUST AIR PRESSURE SETTING OR REPLACE SENSOR, IF FAULTY.
EXCESSIVE MOISTURE IN CONTROL AIR LINE AT AIR CYLINDER	SERVICE CONTROL AIR LINE FILTER DAILY.
IMPROPER FUNCTIONING OF INLET VALVE PISTON	CHECK PISTON AND CYLINDER BORE. REPAIR OR REPLACE AS NEEDED.
JAMMED AIR INLET VALVE ASSEMBLY	CHECK AIR INLET VALVE BUSHING AND SHAFT. CHECK PISTON AND CYLINDER BORE. REPAIR OR REPLACE AS NEEDED.
FAULTY SOLENOID VALVE	REPAIR OR REPLACE AS NECESSARY.
FAULTY SHUTTLE VALVE	REPAIR OR REPLACE AS NECESSARY.
LOOSE WIRING CONNECTIONS AT SOLENOID VALVE/PRESSURE SWITCH	CHECK AND TIGHTEN WIRING TERMINALS.
BROKEN SPRING IN AIR INLET VALVE	REPLACE SPRING.

Compressor Does Not Unload When There Is No Air Demand:

INCORRECT AIR PRESSURE SETTING	ADJUST TO PROPER SETTING.
FAULTY AIR PRESSURE SENSOR	REPLACE SENSOR.
FAULTY BLOWDOWN VALVE	REPAIR OR REPLACE AS NECESSARY.
FAULTY SOLENOID VALVE	REPAIR OR REPLACE AS NECESSARY.
FAULTY DIFFERENTIAL PILOT VALVE	REPAIR OR REPLACE AS NECESSARY.
LEAKS IN CONTROL LINES	CHECK ALL CONTROL LINE FITTINGS AND TUBING.
LEAKS IN SERVICE LINES	CHECK LINES BEFORE MPC VALVE.

Compressor Does Not Revert To Load When Service Line Pressure Drops To Reset Pressure:

FAULTY AIR PRESSURE SENSOR	REPAIR OR REPLACE AS NECESSARY.
LOOSE WIRING CONNECTION	CHECK AND TIGHTEN WIRING TERMINALS.
JAMMED AIR INLET VALVE ASSEMBLY	CHECK AND REPAIR AIR INLET VALVE.
FAULTY SOLENOID	REPAIR OR REPLACE AS NECESSARY.
FAULTY DIFFERENTIAL PILOT VALVE	ORIFICE PLUGGED. CLEAN OR REPLACE AS NECESSARY.

Compressor Will Not Time-out Or Shut Down When Unloaded (Auto/Dual Only):

LEAKS IN CONTROL LINES	CHECK AND REPAIR ANY LEAKS.
LEAKS IN SERVICE LINES	CHECK PLANT AIR DISTRIBUTION SYSTEM FOR LEAKS.
FAULTY AIR PRESSURE SENSORS	REPLACE AS NECESSARY.

Excessive Water in Plant Air Distribution System:

CLOGGED MOISTURE SEPARATOR/TRAP	CLEAN OR REPLACE AS REQUIRED.
INSTALLATION/APPLICATION	CHECK OTHER COMPRESSORS ON SAME SYSTEM.
FAULTY COOLER/LEAKS	REPLACE COOLER.

Pressure Relief Valve Exhausting:

DIFFERENTIAL PRESSURE REGULATOR NOT SET CORRECTLY	ADJUST DIFFERENTIAL PRESSURE REGULATOR TO OBTAIN DESIRED MODULATION RANGE.
AIR PRESSURE NOT SET CORRECTLY	READJUST AIR PRESSURE SWITCH SO THAT THE COMPRESSOR UNLOADS AT THE DESIRED PRESSURE.
AIR INLET VALVE NOT CLOSING PROPERLY IN RELATION TO AIR DEMAND	CORRECT IN ACCORDANCE WITH THE INSTRUCTION IN "INLET VALVE NOT OPENING OR CLOSING IN RELATION TO AIR DEMAND" SECTION OF THIS TROUBLESHOOTING GUIDE.
PLUGGED SEPARATOR	REPLACE WITH NEW AIR/FLUID SEPARATOR.
FAULTY RECEIVER PRESSURE GAUGE	CHECK GAUGE FOR ACCURACY AND REPLACE IF NECESSARY. ADJUST CONTROL SETTINGS.
FAULTY PRESSURE RELIEF VALVE	CHECK PRESSURE RELIEF VALVE FOR CORRECT PRESSURE SETTING. IF VALVE IS STILL LEAKING, REPLACE IT.

Excessive Water Content In Fluid:

WATER DRAIN INTERVALS	DRAIN WATER AS NEEDED TO REDUCE WATER CONTENT IN FLUID BELOW 200 PPM.
DISCHARGE TEMPERATURE TOO LOW	CHECK OPERATION OF THERMOSTATIC VALVE OR WATER REGULATING VALVE. IF CONDITION CONTINUES, CONSULT QUINCY SERVICE DEPARTMENT.

Appendix A - Dimensional Drawings

QGD 20/25/30

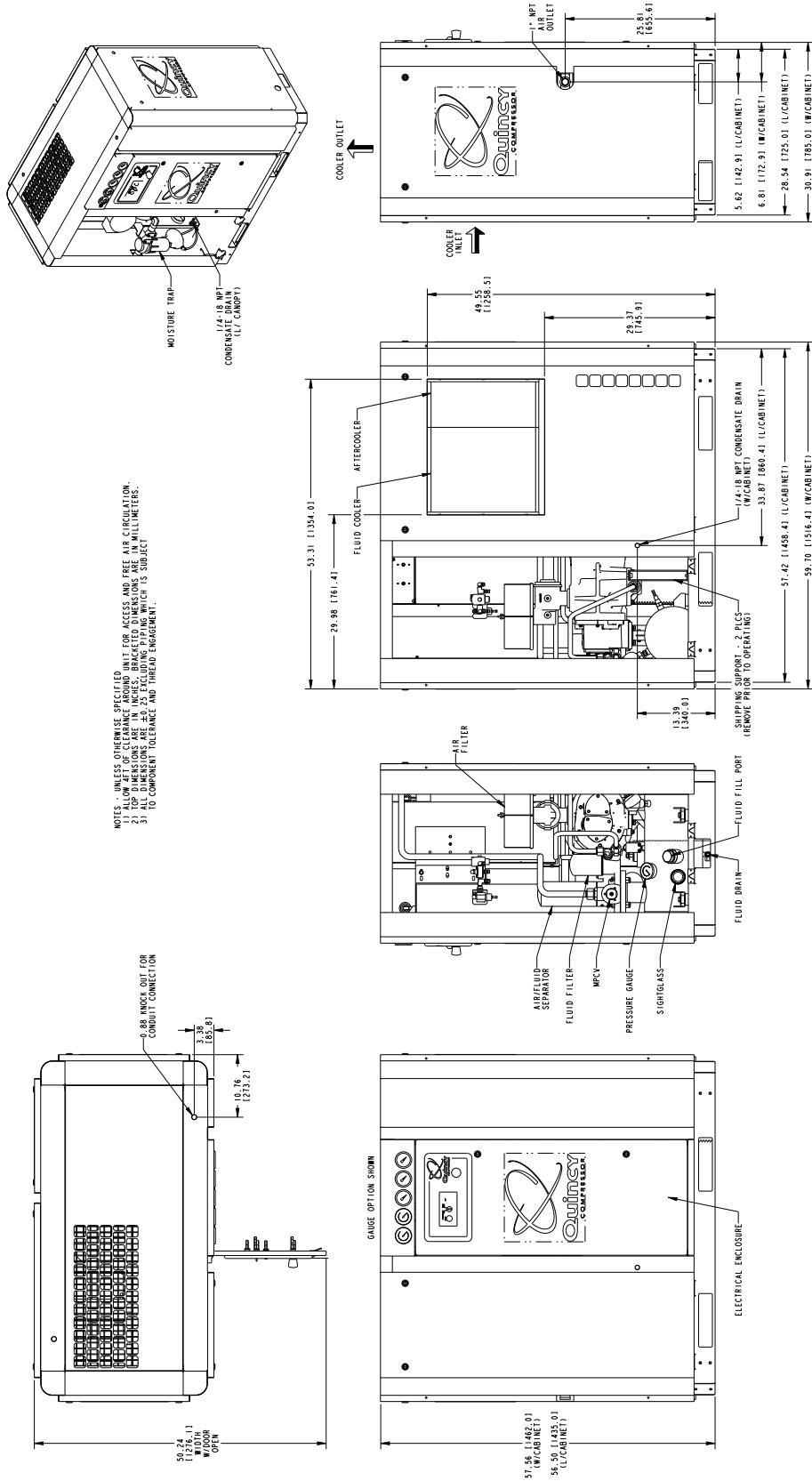

QGD 20/25/30 (tank mounted)

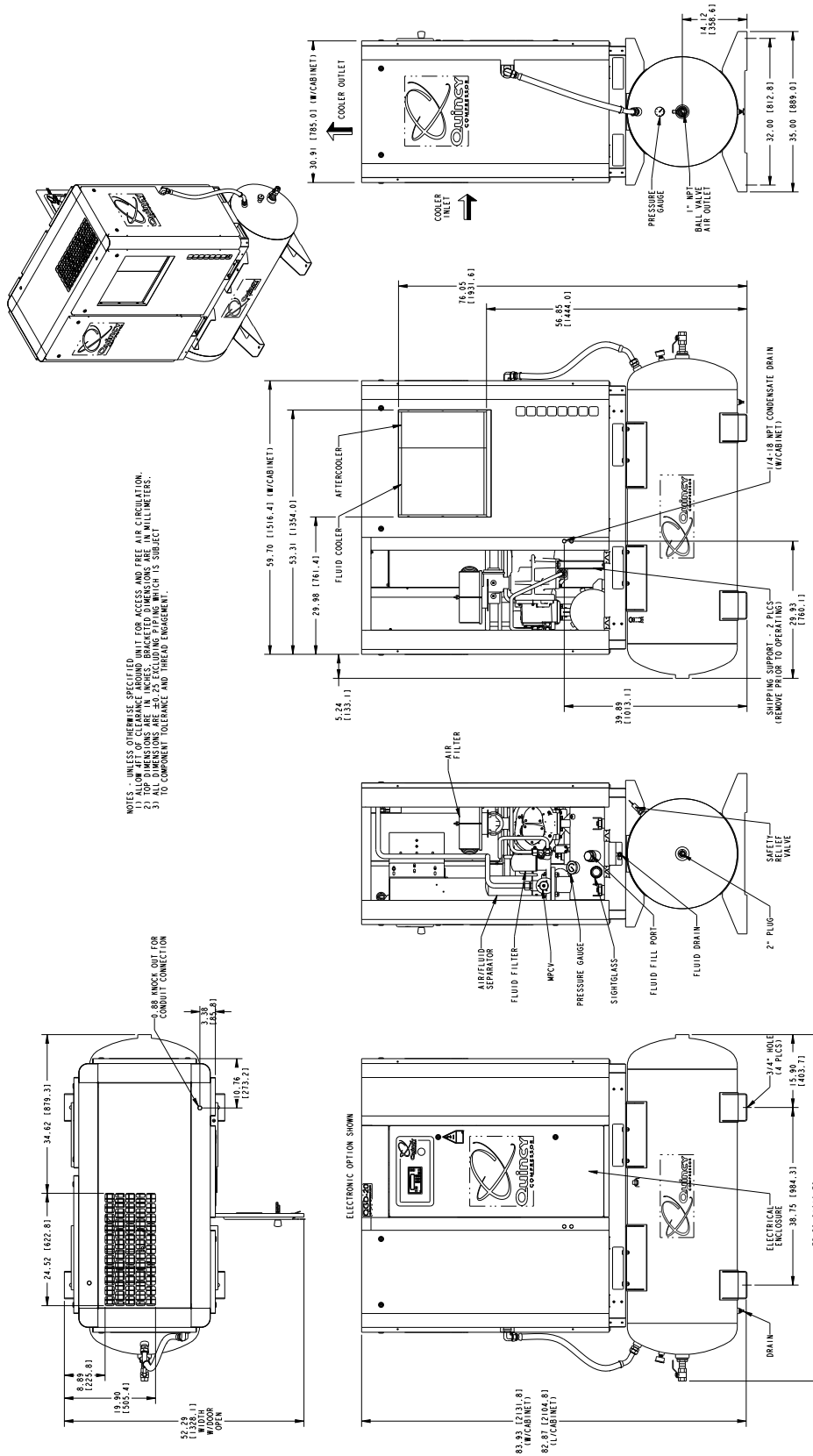

Appendix A - Dimensional Drawings

QGD 40/50

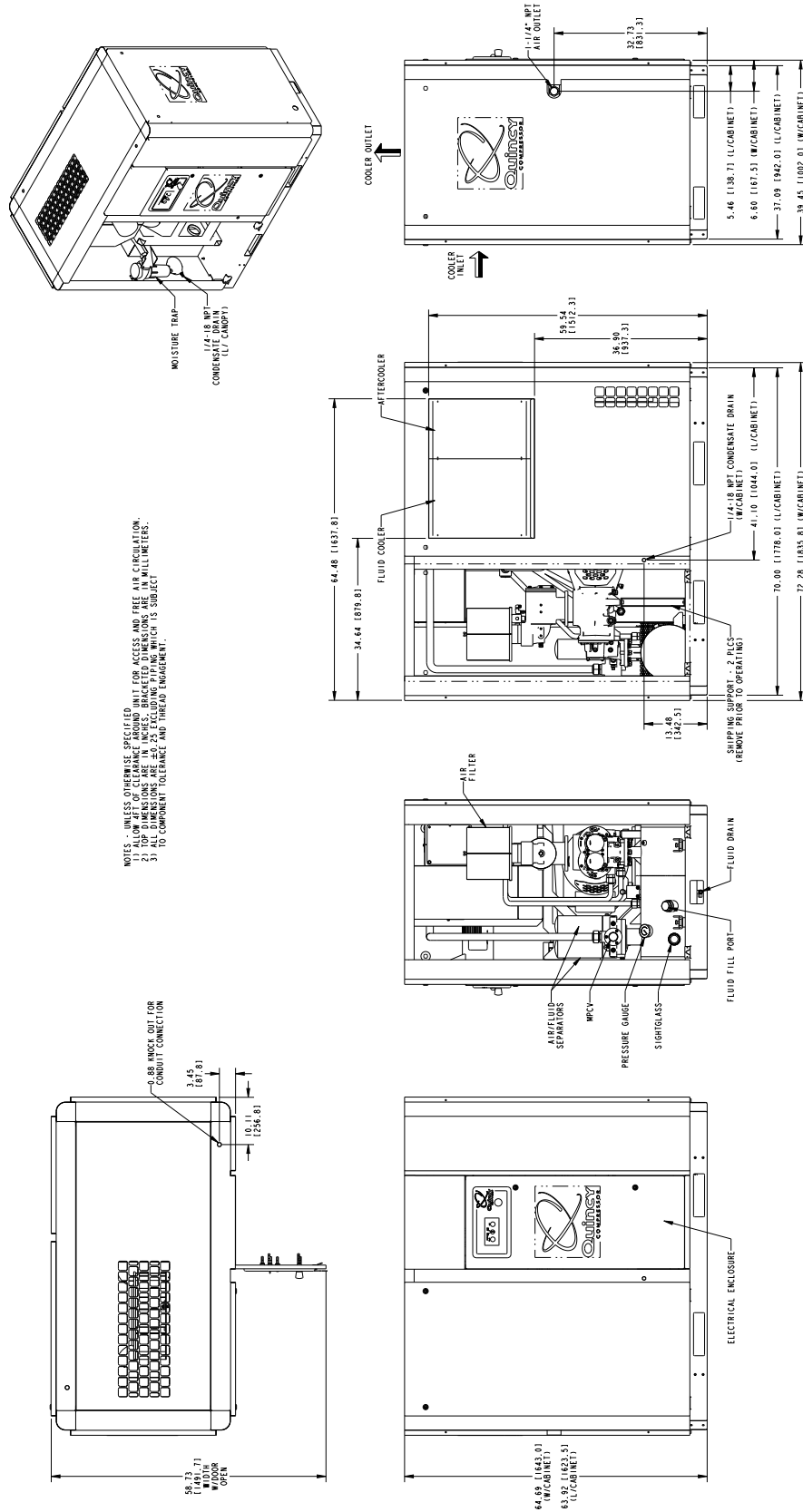

Appendix B - Technical Data

QGD-20

Full Load Operating Pressure		psig	100	125
Maximum Operating Pressure	psig		115	140
Minimum Operating Pressure	psig		75	
Maximum Ambient Operating Temperature	°F		110	
Minimum Ambient Operating Temperature	°F		34	
Compressor Drive Motor	nameplate HP		20	
Inlet Capacity	acfm		89.5	88
Service Line Connection Size	in (npt)		1	
Rotor Diameter	mm		120.5	
Driven Rotor Speed	rpm		3600	
Aftercooling Data				
Heat Rejection - Fluid Cooler	btu/min		806	
Aftercooler	btu/min		198	
Aftercooler Approach to Cooling Air (@ std. conditions)	°F		≤7	
Maximum Static Backpressure	in/H ₂ O		0.125	
Fan Motor	nameplate HP		1	
Fan Motor	rpm		1200	
Fan Flow	cfm		2300	
Compressor Fluid Data				
Fluid Flow	gpm		10.2	11.5
Total Fluid Capacity	gal		4	
Reservoir Fluid Capacity	gal		3	
Normal Airend Discharge Temperature	°F		190	
Sound Data (at 1 meter)				
Unenclosed	dB(A)		77	
Standard Enclosure	dB(A)		70	
Energy Consumption (air-cooled)				
Full Load Drive Motor Power	Bhp		22.23	25.24
Unloaded Drive Motor Power	Bhp		7.3	7.4
Fan Motor Power	Bhp		0.60	
Full Load Drive Motor Consumption	kW		17.74	20.63
Full Load Fan Motor Consumption	kW		0.59	
Total Package Consumption	kW		18.62	21.51
Total Package Specific Power	kW/100 cfm		20.79	24.40
Airend Specific Power	bhp/100 cfm		24.82	28.63
Dimensions				
Length (w/cabinet/l/cabinet/tank mounted)	in		59.7/57.4/75.6	
Width (w/cabinet/l/cabinet/tank mounted)	in		30.9/28.5/35.0	
Height - less tank (with cabinet/less cabinet)	in		57.6/56.6	
Height - with tank (with cabinet/less cabinet)	in		83.9/82.9	
Weight - less tank (with cabinet/less cabinet)	lbs		1078/1300	
Weight - with tank (with cabinet/less cabinet)	lbs		1509/1731	

QGD-25

Full Load Operating Pressure		psig	100	125	150
Maximum Operating Pressure	psig		115	140	160
Minimum Operating Pressure	psig		75		
Maximum Ambient Operating Temperature	°F		110		
Minimum Ambient Operating Temperature	°F		34		
Compressor Drive Motor	nameplate HP		25		
Inlet Capacity	acfm		118	115	87.5
Service Line Connection Size	in (npt)		1		
Rotor Diameter	mm		120.5		
Driven Rotor Speed	rpm		3600		
Aftercooling Data					
Heat Rejection - Fluid Cooler	btu/min		1007		
Aftercooler	btu/min		247		
Aftercooler Approach to Cooling Air (@ std. conditions)	°F		≤7		
Maximum Static Backpressure	in/H2O		0.125		
Fan Motor	nameplate HP		1		
Fan Motor	rpm		1200		
Fan Flow	cfm		2300		
Compressor Fluid Data					
Fluid Flow	gpm		11	12.3	12.2
Total Fluid Capacity	gal		4		
Reservoir Fluid Capacity	gal		3		
Normal Airend Discharge Temperature	°F		190		
Sound Data (at 1 meter)					
Unenclosed	dB(A)		77		
Standard Enclosure	dB(A)		70		
Energy Consumption (air-cooled)					
Full Load Drive Motor Power	Bhp		27.68	30.66	28.23
Unloaded Drive Motor Power	Bhp		8.5	8.1	7.6
Fan Motor Power	Bhp		0.60		
Full Load Drive Motor Consumption	kW		22.30	25.09	22.91
Full Load Fan Motor Consumption	kW		0.59		
Total Package Consumption	kW		23.17	25.82	23.67
Total Package Specific Power	kW/100 cfm		19.63	22.44	27.05
Airend Specific Power	bhp/100 cfm		23.46	26.65	32.26
Dimensions					
Length (w/cabinet/l/cabinet/tank mounted)	in		59.7/57.4/75.6		
Width (w/cabinet/l/cabinet/tank mounted)	in		30.9/28.5/35.0		
Height - less tank (with cabinet/less cabinet)	in		57.6/56.6		
Height - with tank (with cabinet/less cabinet)	in		83.9/82.9		
Weight - less tank (with cabinet/less cabinet)	lbs		1128/1350		
Weight - with tank (with cabinet/less cabinet)	lbs		1559/1781		

Appendix B - Technical Data

QGD-30

Full Load Operating Pressure		psig	100	125	150
Maximum Operating Pressure	psig		115	140	160
Minimum Operating Pressure	psig		75		
Maximum Ambient Operating Temperature	°F		110		
Minimum Ambient Operating Temperature	°F		34		
Compressor Drive Motor	nameplate HP		30		
Inlet Capacity	acfm		132	121	110
Service Line Connection Size	in (npt)		1		
Rotor Diameter	mm		120.5		
Driven Rotor Speed	rpm		3600		
Aftercooling Data					
Heat Rejection - Fluid Cooler	btu/min		1209		
Aftercooler	btu/min		296		
Aftercooler Approach to Cooling Air (@ std. conditions)	°F		≤7		
Maximum Static Backpressure	in H2O		0.125		
Fan Motor	nameplate HP		1		
Fan Motor	rpm		1200		
Fan Flow	cfm		2300		
Compressor Fluid Data					
Fluid Flow	gpm		11.2	13	13.4
Total Fluid Capacity	gal		4		
Reservoir Fluid Capacity	gal		3		
Normal Airend Discharge Temperature	°F		190		
Sound Data (at 1 meter)					
Unenclosed	dB(A)		77		
Standard Enclosure	dB(A)		70		
Energy Consumption (air-cooled)					
Full Load Drive Motor Power	Bhp		31.8	35.0	33.9
Unloaded Drive Motor Power	Bhp		9.5	9.7	8.2
Fan Motor Power	Bhp		0.6		
Full Load Drive Motor Consumption	kW		26.00	28.80	27.78
Full Load Fan Motor Consumption	kW		0.59		
Total Package Consumption	kW		26.48	29.38	28.74
Total Package Specific Power	kW/100 cfm		19.11	20.29	24.49
Airend Specific Power	bhp/100 cfm		22.95	25.95	28.88
Dimensions					
Length (w/cabinet/l/cabinet/tank mounted)	in		59.7/57.4/75.6		
Width (w/cabinet/l/cabinet/tank mounted)	in		30.9/28.5/35.0		
Height - less tank (with cabinet/less cabinet)	in		57.6/56.6		
Height - with tank (with cabinet/less cabinet)	in		83.9/82.9		
Weight - less tank (with cabinet/less cabinet)	lbs		1178/1400		
Weight - with tank (with cabinet/less cabinet)	lbs		1609/1831		

QGD-40

Full Load Operating Pressure		psig	100	125	150
Maximum Operating Pressure	psig		115	140	165
Minimum Operating Pressure	psig		75		
Maximum Ambient Operating Temperature	°F		110		
Minimum Ambient Operating Temperature	°F		34		
Compressor Drive Motor	nameplate HP		40		
Inlet Capacity	acfm		190	161	137
Service Line Connection Size	in (npt)		1.50		
Rotor Diameter	mm		127.5		
Driven Rotor Speed	rpm		3600		
Aftercooling Data					
Heat Rejection - Fluid Cooler	btu/min		1412		
Aftercooler	btu/min		314		
Aftercooler Approach to Cooling Air (@ std. conditions)	°F		≤5		
Maximum Static Backpressure	in/H2O		0.25		
Fan Motor	nameplate HP		1.5		
Fan Motor	rpm		1200		
Fan Flow	cfm		3218		
Compressor Fluid Data					
Fluid Flow	gpm		19	21	22
Total Fluid Capacity	gal		7.5		
Reservoir Fluid Capacity	gal		6		
Normal Airend Discharge Temperature	°F		190		
Sound Data (at 1 meter)					
Unenclosed	dB(A)		79		
Standard Enclosure	dB(A)		72		
Energy Consumption (air-cooled)					
Full Load Drive Motor Power	Bhp		40.5	45.5	44.3
Unloaded Drive Motor Power	Bhp		9.8	9.5	9.5
Fan Motor Power	Bhp		0.8		
Full Load Drive Motor Consumption	kW		32.99	37.05	36.09
Full Load Fan Motor Consumption	kW		0.77		
Total Package Consumption	kW		34.89	38.99	37.06
Total Package Specific Power	kW/100 cfm		18.48	21.42	24.20
Airend Specific Power	bhp/100 cfm		21.45	25.02	28.93
Dimensions					
Length (with cabinet/less cabinet)	in		72.2/70		
Width (with cabinet/less cabinet)	in		39.3/37		
Height (with cabinet/less cabinet)	in		64.7/64		
Weight (with cabinet/less cabinet)	lbs		1493/1780		

Appendix B - Technical Data

QGD-50

Full Load Operating Pressure		psig	100	125	150
Maximum Operating Pressure	psig		115	140	160
Minimum Operating Pressure	psig		75		
Maximum Ambient Operating Temperature	°F		110		
Minimum Ambient Operating Temperature	°F		34		
Compressor Drive Motor	nameplate HP		40		
Inlet Capacity	acfm		225.90	220.70	184.10
Service Line Connection Size	in (npt)		1.50		
Rotor Diameter	mm		143		
Driven Rotor Speed	rpm		3600		
Aftercooling Data					
Heat Rejection - Fluid Cooler	btu/min		1765		
Aftercooler	btu/min		393		
Aftercooler Approach to Cooling Air (@ std. conditions)	°F		≤5		
Maximum Static Backpressure	in/H2O		0.25		
Fan Motor	nameplate HP		1.5		
Fan Motor	rpm		1200		
Fan Flow	cfm		3218		
Compressor Fluid Data					
Fluid Flow	gpm		18.3	21	23
Total Fluid Capacity	gal		7.5		
Reservoir Fluid Capacity	gal		6		
Normal Airend Discharge Temperature	°F		190		
Sound Data (at 1 meter)					
Unenclosed	dB(A)		76		
Standard Enclosure	dB(A)		69		
Energy Consumption (air-cooled)					
Full Load Drive Motor Power	Bhp		50.7	56.3	51.5
Unloaded Drive Motor Power	Bhp		12.0	11.9	10.4
Fan Motor Power	Bhp		0.8		
Full Load Drive Motor Consumption	kW		40.95	45.42	41.61
Full Load Fan Motor Consumption	kW		0.77		
Total Package Consumption	kW		41.47	45.59	43.98
Total Package Specific Power	kW/100 cfm		18.36	20.66	23.89
Airend Specific Power	bhp/100 cfm		22.44	25.51	27.97
Dimensions					
Length (with cabinet/less cabinet)	in		72.2/70		
Width (with cabinet/less cabinet)	in		39.3/37		
Height (with cabinet/less cabinet)	in		64.7/64		
Weight (with cabinet/less cabinet)	lbs		1593/1880		

STANDARD TERMS AND CONDITIONS

QUINCY COMPRESSOR AND ORTMAN FLUID POWER DIVISIONS

LEGAL EFFECT: Except as expressly otherwise agreed to in writing by an authorized representative of Seller, the following terms and conditions shall apply to and form a part of this order and any additional and/or different terms of Buyer's purchase order or other form of acceptance are rejected in advance and shall not become a part of this order.

The rights of Buyer hereunder shall be neither assignable nor transferable except with the written consent of Seller.

This order may not be canceled or altered except with the written consent of Seller and upon terms which will indemnify Seller against all loss occasioned thereby. All additional costs incurred by Seller due to changes in design or specifications, modification of this order or revision of product must be paid for by Buyer.

In addition to the rights and remedies conferred upon Seller by this order, Seller shall have all rights and remedies conferred at law and in equity and shall not be required to proceed with the performance of this order if Buyer is in default in the performance of such order or of any other contract or order with seller.

TERMS OF PAYMENT: Unless otherwise specified in the order acknowledgment, the terms of payment shall be net cash within thirty (30) days after shipment. These terms shall apply to partial as well as complete shipments. If any proceeding be initiated by or against Buyer under any bankruptcy or insolvency law, or in the judgment of Seller the financial condition of Buyer, at the time the equipment is ready for shipment, does not justify the terms of payment specified, Seller reserves the right to require full payment in cash prior to making shipment. If such payment is not received within fifteen (15) days after notification of readiness for shipment, Seller may cancel the order as to any unshipped item and require payment of its reasonable cancellation charges.

If Buyer delays shipment, payments based on date of shipment shall become due as of the date when ready for shipment. If Buyer delays completion of manufacture, Seller may elect to require payment according to percentage of completion. Equipment held for Buyer shall be at Buyer's risk and storage charges may be applied at the discretion of Seller.

Accounts past due shall bear interest at the highest rate lawful to contract for but if there is no limit set by law, such interest shall be eighteen percent (18%). Buyer shall pay all cost and expenses, including reasonable attorney's fees, incurred in collecting the same, and no claim, except claims within Seller's warranty of material or workmanship, as stated below, will be recognized unless delivered in writing to Seller within thirty (30) days after date of shipment.

TAXES: All prices exclude present and future sales, use, occupation, license, excise, and other taxes in respect of manufacture, sales or delivery, all of which shall be paid by Buyer unless included in the purchase price at the proper rate or a proper exemption certificate is furnished.

ACCEPTANCE: All offers to purchase, quotations and contracts of sales are subject to final acceptance by an authorized representative at Seller's plant.

DELIVERY: Except as otherwise specified in this quotation, delivery will be F. O. B. point of shipment. In the absence of exact shipping instruction, Seller will use its discretion regarding best means of insured shipment. No liability will be accepted by Seller for so doing. All transportation charges are at Buyer's expense. Time of delivery is an estimate only and is based upon the receipt of all information and necessary approvals. The shipping schedule shall not be construed to limit seller in making commitments for materials or in fabricating articles under this order in accordance with Seller's normal and reasonable production schedules.

Seller shall in no event be liable for delays caused by fires, acts of God, strikes, labor difficulties, acts of governmental or military authorities, delays in transportation or procuring materials, or causes of any kind beyond Seller's control. No provision for liquidated damages for any cause shall apply under this order. Buyer shall accept delivery within thirty (30) days after receipt of notification of readiness for shipment. Claims for shortages will be deemed to have been waived if not made in writing within ten (10) days after the receipt of the material in respect of which any such shortage is claimed. Seller is not responsible for loss or damage in transit after having received "In Good Order" receipt from the carrier. All claims for loss or damage in transit should be made to the carrier.

STANDARD TERMS AND CONDITIONS

QUINCY COMPRESSOR AND ORTMAN FLUID POWER DIVISIONS

TITLE & LIEN RIGHTS: The equipment shall remain personal property, regardless of how affixed to any realty or structure. Until the price (including any notes given therefore) of the equipment has been fully paid in cash, Seller shall, in the event of Buyer's default, have the right to repossess such equipment.

PATENT INFRINGEMENT: If properly notified and given an opportunity to do so with friendly assistance, Seller will defend Buyer and the ultimate user of the equipment from any actual or alleged infringement of any published United States patent by the equipment or any part thereof furnished pursuant hereto (other than parts of special design, construction, or manufacture specified by and originating with Buyer), and will pay all damages and costs awarded by competent court in any suit thus defended or of which it may have had notice and opportunity to defend as aforesaid.

STANDARD WARRANTY: Seller warrants that products of its own manufacture will be free from defects in workmanship and materials under normal use and service for the period specified in the product instruction manual. Warranty for service parts will be ninety (90) days from date of factory shipment. Electric Motors, gasoline and diesel engines, electrical apparatus and all other accessories, components and parts not manufactured by Seller are warranted only to the extent of the original manufacturer's warranty.

Notice of the alleged defect must be given to the Seller, in writing with all identifying details including serial number, type of equipment and date of purchase within thirty (30) days of the discovery of the same during the warranty period.

Seller's sole obligation on this warranty shall be, at its option, to repair or replace or refund the purchase price of any product or part thereof which proves to be defective. If requested by Seller, such product or part thereof must be promptly returned to seller, freight prepaid, for inspection.

Seller warrants repaired or replaced parts of its own manufacture against defects in materials and workmanship under normal use and service for ninety (90) days or for the remainder of the warranty on the product being repaired.

This warranty shall not apply and Seller shall not be responsible or liable for:

- (a) Consequential, collateral or special losses or damages;
- (b) Equipment conditions caused by fair wear and tear, abnormal conditions of use, accident, neglect or misuse of equipment, improper storage or damage resulting during shipping;
- (c) Deviation from operating instructions, specifications or other special terms of sale;
- (d) Labor charges, loss or damage resulting from improper operation, maintenance or repairs made by person(s) other than Seller or Seller's authorized service station.

In no event shall Seller be liable for any claims whether arising from breach of contract or warranty or claims of negligence or negligent manufacture in excess of the purchase price.

THIS WARRANTY IS THE SOLE WARRANTY OF SELLERS AND ANY OTHER WARRANTIES, WHETHER EXPRESS OR IMPLIED IN LAW OR IMPLIED IN FACT, INCLUDING ANY WARRANTIES OF MERCHANTABILITY AND FITNESS FOR PARTICULAR USE ARE HEREBY SPECIFICALLY EXCLUDED.

LIABILITY LIMITATIONS: Under no circumstances shall the Seller have any liability for liquidated damages or for collateral, consequential or special damages or for loss of profits, or for actual losses or for loss of production or progress of construction, whether resulting from delays in delivery or performance, breach of warranty, negligent manufacture or otherwise.

ENVIRONMENTAL AND OSHA REQUIREMENTS: At the time of shipment of the equipment from the factory, Quincy Compressor / Ortman Fluid Power will comply with the various Federal, State and local laws and regulations concerning occupational health and safety and pollution. However, in the installation and operation of the equipment and other matters over which the seller has no control, the Seller assumes no responsibility for compliance with those laws and regulations, whether by the way of indemnity, warranty or otherwise.



an EnPro Industries company

Quincy Compressor Products: 217.222.7700

E-mail: info@quincycompressor.com

Website: www.quincycompressor.com



© 2009 Quincy Compressor, an EnPro Industries company
All Rights Reserved. Litho in U.S.A.