

namao



NXC series cycling refrigerated air dryer
user guide

Experience.

Our team is comprised of and supported by individuals spanning all disciplines from research & development, engineering & manufacturing, marketing & sales and service & support. Our backgrounds are in air and gas purification and our experience in this field spans a wide range of industries. We combine this knowledge and experience to ensure our products and services are designed and provided to meet the objectives and expectations of you - our Customer.



Customer.

We recognize that our Customers are not only our valuable distribution partners who sell and support our products or the machine builders who depend on them as protection for their equipment. They are the contractors who install them, the manufacturers who use them in their processes and the service people who maintain them. At nano we have developed our products, packaging and support materials to ensure they exceed all of our Customers' expectations.



Service.

At nano we recognize that world-class customer service is the most important component to any successful business. Your business needs to exceed your customers' expectations to stand out from your competitors and our service must positively impact your business so you can be successful in doing so. Our commitment is simple... we will stand behind our products and ensure that our customer service is unrivaled in the industry.



Experience. Customer. Service.



table of contents

| section | description | page |
|----------------|--|-------------|
| 1 | 1.1 general information | 4 |
| | 1.2 manufacturers details and support | |
| | 1.3 document introduction | |
| | 1.4 warranty guidelines | 5 |
| | 1.5 general warnings | |
| | 1.6 basic safety rules | |
| | 1.7 qualified operators | 7 |
| | 1.8 safety | 8 |
| | 1.9 storage | 9 |
| | 1.10 transport and handling | |
| 2 | 2.1 compressed air installation principle | 11 |
| | 2.2 machine code identification | |
| | 2.3 operating principle of the dryer | 12 |
| | 2.4 installation | 13 |
| | 2.5 by pass | 15 |
| | 2.6 operation | 16 |
| | 2.7 use | 17 |
| | 2.8 controller instructions | 18 |
| | 2.9 safety system | 21 |
| | 2.10 routine maintenance | |
| | 2.11 trouble shooting in the event of malfunction | 22 |
| | 2.12 maintenance | 23 |
| | 2.13 trouble shooting | 28 |
| 3 | 3.1 arrangement drawings | 31 |
| | 3.2 exploded views and spare parts | 37 |
| | 3.3 electrical wirings | 47 |
| | 3.4 appendixes | 51 |
| 4 | 4.1 R407c chemical safety data sheets | 52 |
| | 4.2 R134a chemical safety data sheets | 57 |



R¹ cycling refrigerated air dryer

1

1.1 general information

This manual is copyrighted, all rights reserved. It may not, in whole or in part, be copied, photocopied, reproduced, translated, or reduced to any electronic medium or machine readable form without prior consent in writing from nano-purification solutions. It may not be distributed through the internet or computer bulletin board systems without prior consent from nano-purification solutions.

©2018 nano-purification solutions.

range: R¹ refrigerated air dryers
models: NXC 0020 - 2000
doc no: 17-110-8002
issue: 003

1.2 manufacturers details and support

nano-purification solutions llc

address: 5509 david cox road
charlotte, nc 28269
usa
telephone: 704.897.2182
fax: 704.897.2183
internet: www.n-psi.com
e-mail: support@n-psi.com

nano-purification solutions ltd

address: dukesway
team valley trading estate
gateshead
ne11 opz
united kingdom
telephone: +44 (0) 191 497 7700
internet: www.n-psi.co.uk
e-mail: enquiries@n-psi.co.uk

nano-purification solutions

address: unit 8b
188 bunting road, unit 8B
st catharines, ontario
l2m 3y1
canada
telephone: 704.897.2182
internet: www.n-psi.com
e-mail: support@n-psi.com



annotations



CAUTIONS: indicate any situation or operation that may result in potential damage to the product, injury to the user, or render the product unsafe.



NOTES: highlight important sections of information where particular care and attention should be paid.



1.3 document introduction

This manual is meant for anyone who uses or works on the cycling refrigerated air dryer, mainly the operators. The cycling refrigerated air dryer and this manual are protected by copyright. Any reproduction of the same shall be liable for prosecution. All rights reserved by **nano-purification solutions**, particularly the rights of reproduction and distribution, as well as translation, including those relating to charges of copyright infringement. Any reproduction, processing, duplication, distribution of this document using electronic or mechanical means without the prior written authorization of **nano-purification solutions** is strictly prohibited. This document may have errors and is likely to be modified with respect to technical features.

1.4 warranty guidelines

All products are supplied with a 30 months manufacturer's warranty from the date of shipment from the factory or 24 months from date of installation/start up, whichever occurs first and installed and maintained in accordance with the manufacturers guidelines. Pre-filters and non-corrosive upstream piping required. Only genuine service parts should be used and no modifications made.

1.5 general warnings



Read the contents of this manual carefully before starting the units.



This service and maintenance manual describes the design, operation and the instructions for use and maintenance of the units manufactured by **nano-purification solutions**.



nano-purification solutions shall not be liable for any damage caused due to non-compliance with the instructions of this manual.



For the smallest doubts or any clarifications that may be required, our qualified **nano-purification solutions** technicians are available to provide all the necessary information.



In order to make it easier to identify the units, it is important to always specify the technical features, especially the serial number, which are printed on the label on the outside of the units.



The unit should not be operated, even for a short period of time, under conditions other than the ideal conditions.



A part that does not guarantee safety should not be installed.



WARNING: This product can expose you to chemicals including lead, which is known to the State of California to cause cancer and/or birth defects or other reproductive harm. For more information, go to www.P65Warnings.com.

1.6 basic safety rules



The installer must provide an emergency stop button on the unit. They should ensure that this is done before the unit is started.



The unit is equipped with protective covers for the components. If the unit is installed outdoors, it is important to arrange for a canopy to protect it from the snow, which could constitute a risk while using the unit if the fan blades freeze.



Replace all the supply lines of the different power sources which are damaged or missing.



Depending on the version, the refrigerants used can be either R407c or R134a. They are not harmful unless inhaled. They constitute a hazard only if they saturate the environment. Some fluids are flammable under certain conditions. Refer to the specifications of each fluid on the [safety data sheet at the end of the manual](#).



R¹ cycling refrigerated air dryer

1



The compressor lubricant is not hazardous. However, it is always compulsory to wear safety gloves while working with it. Do not swallow the lubricant.



For any operations relating to the installation, commissioning, fitting, use, modifications of the conditions of use and methods, routine maintenance, inspection and scheduled maintenance, follow the procedures given in the corresponding chapters of this manual. Keep this manual at hand for quick reference.



The unit must be used under the conditions specified in this service and maintenance manual.

There are some recommendations given below for the **USER** that should help to avoid abnormal operating conditions. Avoid any operating conditions other than those expressly described in this manual.



Do not climb on the unit;



Operate the unit after it is properly installed in the recommended position;



Operate the unit after it is properly installed in the recommended position;



Do not start the unit without the protecting covers properly in place;



Do not remove the protecting covers while the unit is functioning;



Do not remove the protecting covers when the unit is switched on;



Do not clean the unit when it is in operation;

Do not install the unit in corrosive or explosive places;

nano-purification solutions shall not be held responsible for any possible damage caused, directly or indirectly, by persons or elements that are not non-compliant with these instructions.

Any assembling/removal carried out by THE USER, which is not provided for in this manual or not authorized by “nano-purification solutions”, will be considered as an inappropriate operation, thereby damaging safety functions, and will lead to the cancellation of the warranty.



1.7 qualified operators

Only the professionals stated below are authorized to operate the unit after having received all the necessary instructions from this manual:

Specialized maintenance electrician

The electrician should have a general knowledge about electrical appliances as well as specific experience working with control boxes and the electrical components of cooling units or similar equipment from the domain of air-conditioning. The electrician is authorized to carry out only the specific operations stated in this manual by meticulously following the associated instructions.

Maintenance technician

The maintenance technician should have a general experience working with mechanical elements and a specific experience with cooling units or similar equipment from the domain of air-conditioning. The maintenance technician is authorized to carry out only the specific operations stated in this manual by meticulously following the associated instructions.

Refrigeration technician

The refrigeration technician should be a refrigeration certified from a technical institution for similar equipment or interventions under the authority of competent personnel.

The refrigeration technician is authorized to carry out only the specific operations stated in this manual by meticulously following the associated instructions.

Transport operator

The transport operator can carry out only the specific operations stated in this manual by meticulously following the associated instructions.

Staff allocated for the start-up and shut-down of the unit

(Basic operator and engineer operator)

After having understood the information contained in this manual, the basic operator will be authorized to manually operate the unit at the level of the following functions: start-up, shut-down, display of alarms.

In this case, this operator can carry out only the specific operations stated in this manual by meticulously following the associated instructions.

Safety officer

The safety officer is responsible for protection and the prevention of occupational risks as set forth in **OSHA Directive** (Safety in the workplace).

The safety officer shall make certain that all the persons who operate the unit have received all applicable instructions which are contained in this manual, including the initial installation and commissioning operation.





R¹ cycling refrigerated air dryer

1

1.8 safety

Essential safety rules

! WARNING

Read this paragraph carefully and understand it before operating or

servicing this machine. The machine is connected to hazardous power circuits (electricity, pneumatic circuit, etc.) and should be used with great care. This paragraph explains what needs to be understood in terms of safety before operating or servicing the machine. Non-compliance with these safety instructions risks causing injuries or fatal accidents, break-down of the machine, products (plates) or installations, or a serious incident.

Operator

- Prior training about the operation and maintenance of the device is a prerequisite for the use and maintenance of the dryer.
- Use and maintain the dryer with the consent of the system manager.
- It is very dangerous to let a person, with poor knowledge and poor understanding about the system and how the machine functions, use it and carry out maintenance operations in an improper or negligent manner.

Before operating the dryer:

- Anyone using the dryer or carrying out its maintenance operations must read this manual carefully and understand its contents. Pay special attention to explanations with the heading “Danger”, “Warning” and “Caution” and understand them thoroughly. Follow the instructions and avoid predictable hazards when you use the dryer or carry out its maintenance operations.
- Before operating or carrying out a maintenance operation, read and understand the safety instructions stated in this manual and the safety labels affixed, on the device, and follow the instructions. Failing the above, you risk suffering facial injuries or even fatal injuries. You also run the risk of the dryer, the products (plates) or the installation breaking down or causing a serious incident.
- Other safety instructions are provided in the other paragraphs.

Warning labels (Warning)

- Warning labels are very important. Do not remove them deliberately.
- If they become dirty or illegible, or they get removed inadvertently or are lost, stick new labels in the place of the earlier ones.

Danger warning

When you use the dryer or carry out a maintenance operation on it, pay attention to the three warning levels below. Understand their content and act accordingly.

The warning messages appear on the warning labels stuck on the dryer and given in the safety instructions paragraph of this manual.

! DANGER

The “danger” messages provide warning about real dangers and

indicate the risks of fatal accident or serious injuries for the operator who does not strictly adhere to the safety instructions provided to avoid such dangers. They also provide warning about the risks of an accidental gas leakage or fire due to improper handling.

The content of the messages is identical to the warning messages, except for indicating a higher level of severity. Danger labels generally have a red background.

! WARNING

The “warning” messages provide warning about real dangers and

indicate the risks of serious injuries or fatal accident for the operator who does not strictly adhere to the safety instructions provided to avoid such dangers. They also provide warning about the risks of an accidental gas leakage or fire due to improper handling. Warning labels generally have an orange background.





! CAUTION

The “caution” messages provide warning about real

dangers and indicate the risks of minor injuries for the operator, or damage to the system, products (plates) and installations, if they do not strictly adhere to the safety instructions provided to avoid such dangers.

Caution labels generally have a yellow background.

1.9 storage

Keep away from:

- Direct sunshine, rain, wind and sand.
- Temperature: max. 140°F/min. 14°F
- Max. relative humidity: 90%

1.10 transport and handling



The carrier is always liable for any damage caused to the products entrusted to them during transport. Thus, before preparing the unit for its installation and commissioning, it is necessary to carry out a complete visual inspection in order to check that the packing cases are intact and the unit has no apparent damage and that there is no oil or refrigerant leakage. It is also important to verify that the units are the ones that have been ordered.



Any damage or complaints must be reported to **nano-purification solutions** and declared to the carrier (or shipper) before the carrier leaves premises when product is delivered.



If there is damage to one or more components, do not start the unit but inform **nano-purification solutions** about the problem to find a mutually agreeable course of action.



Preferably, remove the packaging at the actual place of installation. The unit should be handled with great care on the premises. Do not use any of its components as a grip. In order to avoid any damage, it is imperative that, during their handling,

the units always remain in the position set for their operation.



Do not leave the units in their packaging on premises that are exposed to strong sunshine because the ambient temperatures can affect the triggering values of the safety devices.



The water circuit should be completely drained before the unit is handled.



The equipment should be preferably lifted using a forklift truck. Use a spreader bar if belts or slings are used and ensure that there is no pressure on the external edges of the units or the packing case.





R¹ cycling refrigerated air dryer

1

During transport, do not place the dryer on the ground, on the side, in order to avoid any possible problem.

Example of lifting using a forklift truck:

- Insert the protection for the external structure of the unit, e.g. polystyrene or board sheet (A).
- Ensure that the forks of the truck jut out min. 4 inches (B) from the unit.

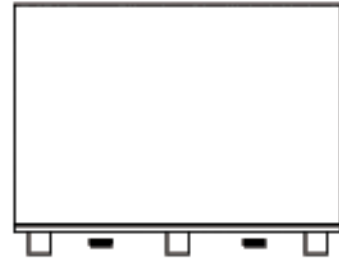
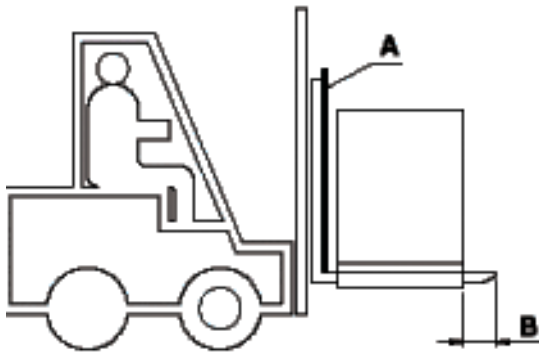

Example of lifting using slings:

- Place the slings as shown.
- Place the rigid structures on the upper sides of the unit in order to avoid damaging it (only when there is a point on which the pressure acts).
- Tighten the slings **gradually**, while ensuring that they remain in the correct position.
- Start lifting the unit.

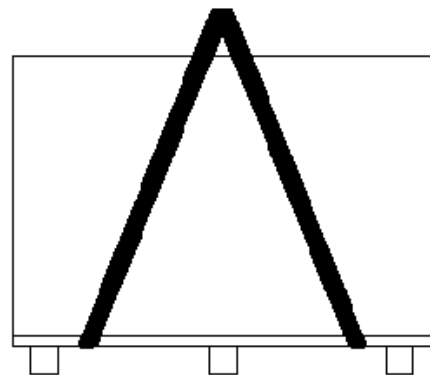

R¹

cycling refrigerated air dryer



2.1 compressed air installation principle

! A backup wrench must be used when tightening air inlet and outlet pipework connections. Failure to properly tighten inlet and outlet pipework without use of a backup wrench could result in damage to the dryer and void warranty.

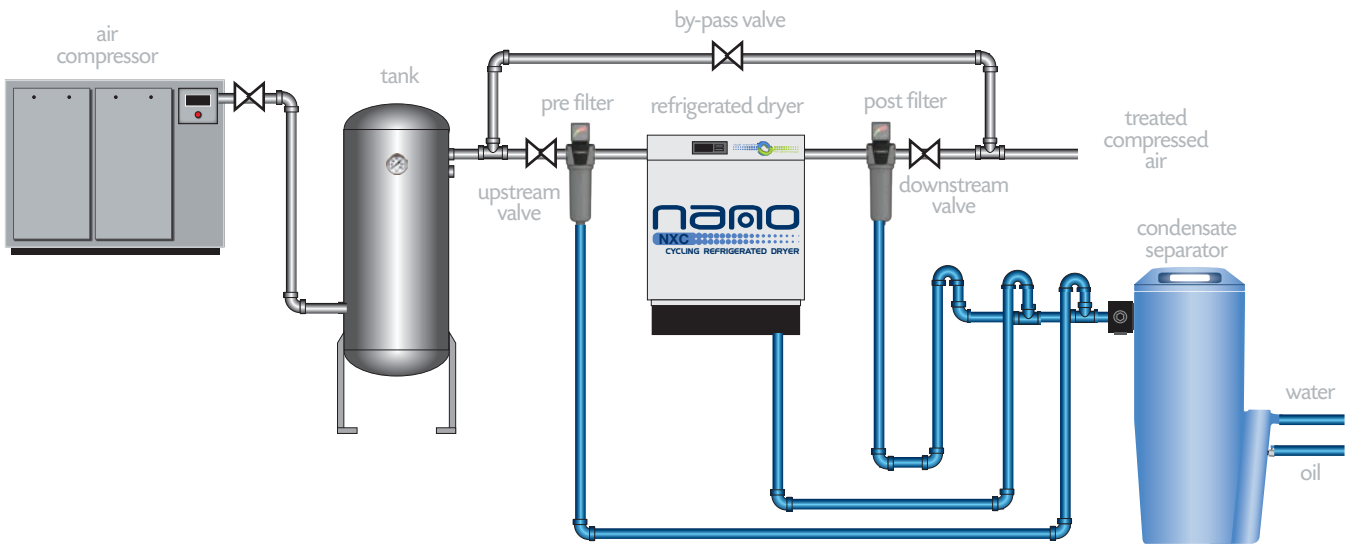

2

2.2 machine code identification

The model of the machine, on the rating plate, it's very easy to recognize it by the name (see example).

NXC XXXX - AAA/B/60Hz

name of range

model in the range

electrical supply
AAA: voltage in V
B: number of phases





R¹ cycling refrigerated air dryer

2.3 operating principle of the dryer

Schematic diagram

NXC 0020 to NXC 0110

2

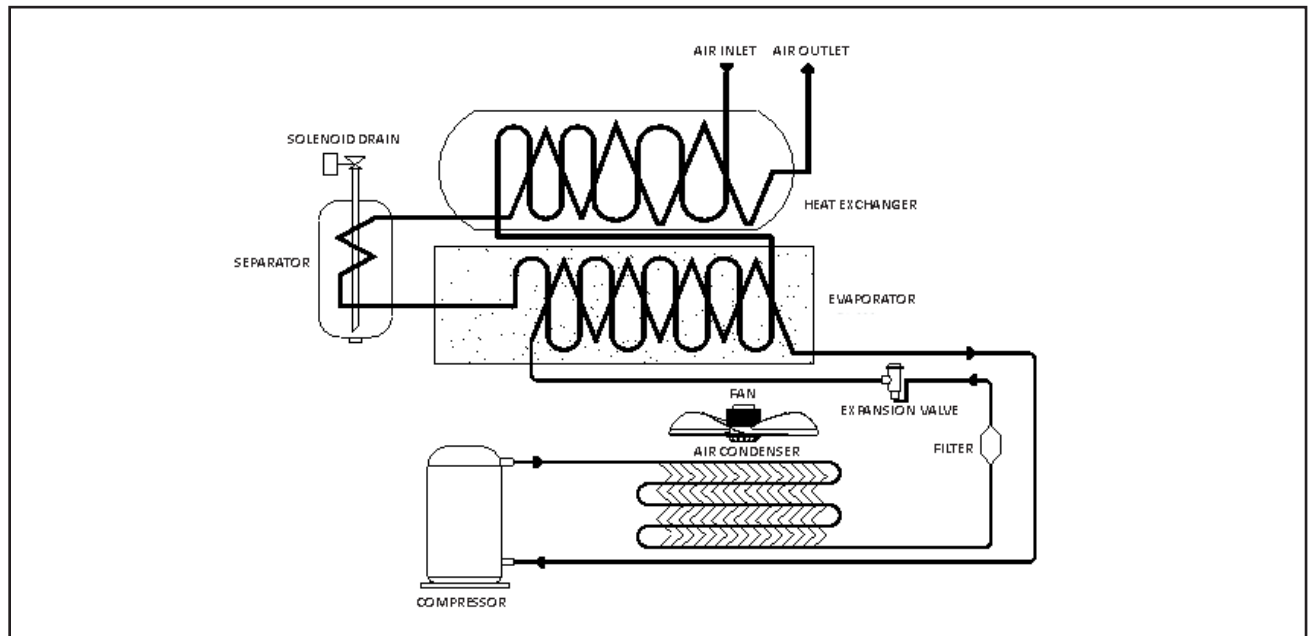

NXC 0130 to NXC 2000

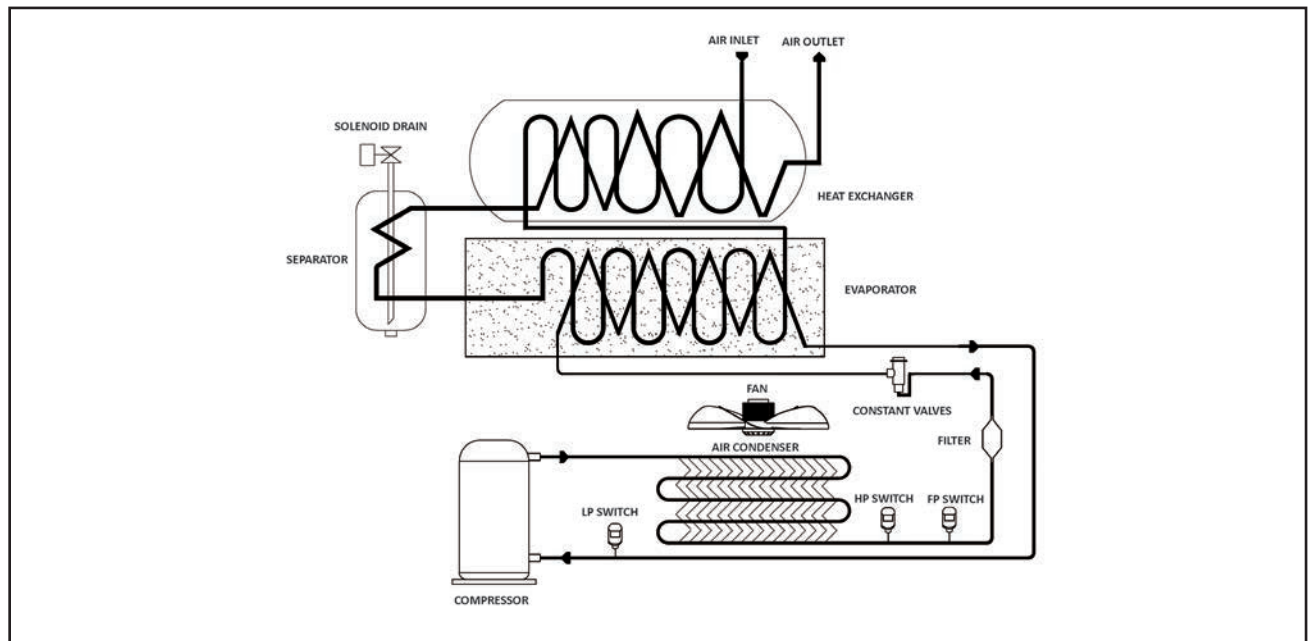

R¹

cycling refrigerated air dryer



2.4 installation

Note: These instructions help to improve the service durability of the equipment. Please read them carefully and follow them.

Location of the compressed air dryer

1. Locate the air dryer on a surface in a horizontal position.
2. The air dryer can corrode quickly if it is located on a surface that is contaminated by acid or alkali.
3. The location of installation should be clear and have sufficient space. (Blocked air circulation reduces the rate of dehumidification and the service life of the dryer).
Allow 5 feet of clear space around the dryer to facilitate maintenance operations and repairs.
4. The ambient temperature where the air dryer is installed should be greater than 32°F to avoid the dryer freezing. The location should not have direct exposure to sun rays.
Ambient temperature for dryers using R-134a (34-122°F); using R-407c (34-110°F).
 - * It is necessary to arrange for suitable ventilation in order to prevent any malfunctioning.
 - * If ambient temperature can fall to 32°F or below, contact your supplier to obtain specific installation or air dryer recommendations.
5. There should be no flammable products at the place of installation.

2





R¹ cycling refrigerated air dryer

Piping

The compressed air pipework should be installed using standard tools and connected in such a way that there is no AIR leaking from the connections. Any malfunction and leakage in the system can be avoided with an installation that is properly adjusted taking into account the possible movements and loosening of the connections for due to vibration and temperature change.

2

1. The compressed air piping should be assembled in accordance with the direction of circulation of the compressed air after inspection of the inlet and outlet of the AIR DRYER. (Assembling the piping in the wrong direction causes the AIR DRYER to malfunction).
2. The compressed air piping should not rest directly on the AIR DRYER but on a support so that they are isolated from the device.
3. Condensed water coming from the outlet of the drain device should be evacuated through a separate condensate line, to a properly sized oil water separator.
4. The AIR DRYER should be isolated from the vibrations of the AIR COMPRESSOR.
5. It is recommended to use non-corrosive piping for better corrosion resistance.
6. It is recommended to install a bypass in order to facilitate servicing the AIR DRYER.



R¹

cycling refrigerated air dryer



2.5 by pass

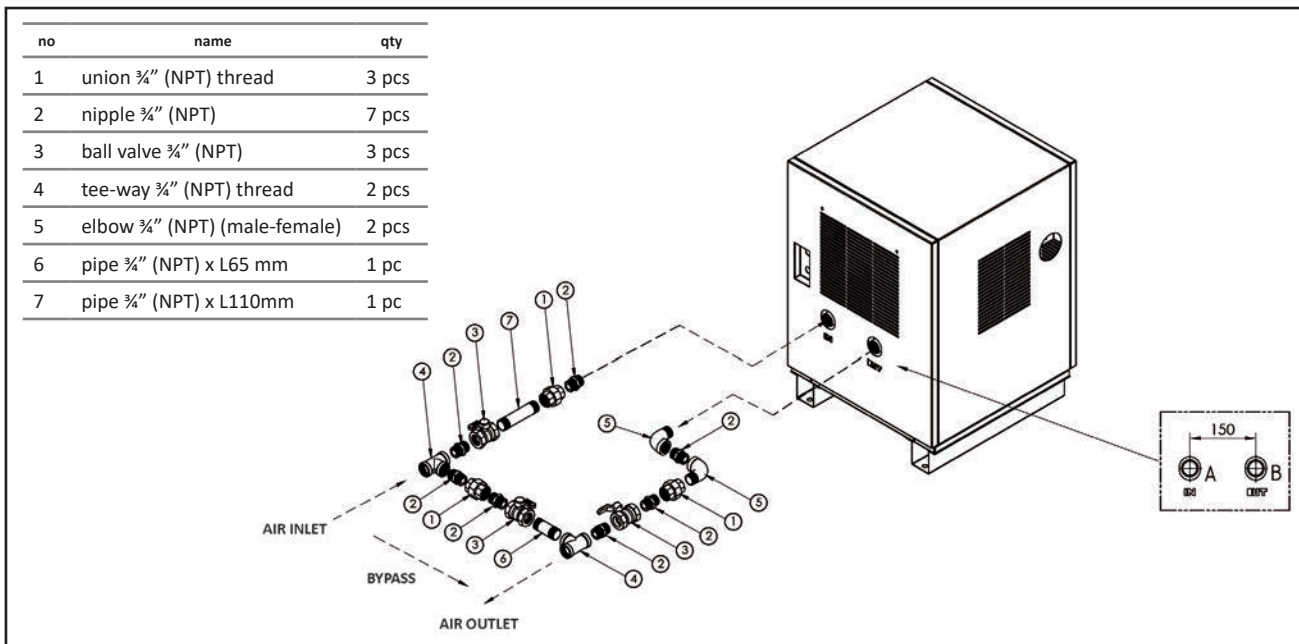

2

Note:

Illustration is for example purposes only. Inlet and outlet connections as well as dimensional information will vary by model. Refer to the drawing of your specific model air dryer and consult with a compressed air piping contractor for appropriate installation.





R¹ cycling refrigerated air dryer

Electrical connection

1. Connection : Use conductors which can carry the maximum current required at the maximum ambient operating temperature, according the type of installation chosen (see indication on the electrical diagram). Use only UL marked copper cables in conformity with NEC (National Electrical Code) and CEC (Canadian Electrical Code).
2. Appropriate protection should be installed to avoid over current and possible electrocution due to short-circuit before installing the air dryer.
3. Proper grounding should be installed.
4. Permissible operating voltage range: $\pm 5\%$
5. Refer to the electrical schematic and direct any questions to **nano-purification solutions** technical support.

2.6 operation

Function test

Start the air dryer after the following checks are made:

Inspection of the components:

1. Is there a problem in the air system and electric circuit?
2. Has the by-pass circuit valve (optional) been closed?
3. Is the purge system valve open?
4. Is the compressed air pressure sufficient?
5. Is there a differential between the permissible rated voltage and the interrupting capacity of the fuses and the circuit-breaker?

Operating procedure

Press the “ON” power button (press the button of the controller in the front and hold for 5 seconds on CAREL controllers)

We recommend to start the dryer, prior to opening up the air inlet and outlet valves for five minutes. After starting the unit and running it for five minutes slowly pressurize the dryer to avoid any possible damage. The condensate drain should be cycled to ensure functionality and then slowly open the outlet valve to the system.

(If compressed air enters the dryer quickly, the pressure could damage parts or instruments).

❖ Important ❖

Wait for more than 5 minutes before restarting the dryer.

R¹ cycling refrigerated air dryer



2.7 use

Initial start-up of NXC Cycling refrigerated air dryer



Only start up the dryer once you have thoroughly tested all the compressed air, refrigeration and electrical connections.

2

1. Close the isolating valves on the dryer and open the by-pass valve.
2. Check on the controller that the dryer is OFF.
3. Start the air compressor.
4. Start the dryer. (press on the arrow up button, the controller will display ON)
5. The refrigerating compressor and condenser fan will start after a 2-minute safety time-out interval.
6. Always turn your dryer ON 10 to 15 minutes before the air compressor.
7. Pressurize the dryer by slowly opening the inlet valve.
8. Slowly open the dryer outlet valve and then close the by-pass.
9. Check that the condensate drain opens when you push the arrow's down button.
10. Check that the condensate drain valve opens automatically every 5 minutes.

The dryer is now ready to run normally.

Normal start-up

The following key points will optimize daily use:

- Always turn your dryer ON 10 to 15 minutes before the air compressor. This will ensure that the heat exchanger has been cooled to a proper level to handle the initial thermal load of the compressed air.
- The NXC cycling refrigerated air dryer has been designed as an energy efficient air dryer and can remain on even when compressed air production has stopped. The electronic regulation will automatically start and stop the refrigeration compressor based on the demand on the system. You only need to turn off your air dryer at night, on the weekend or during system shut down.
- The standard dryer parameters programmed in our factory meet the needs of most applications. If the conditions in your plant are typical (i.e. not a very hot environment, no partial drying upstream, no voluntary increase in the dew point...), do not spend time on modifying these parameters.





R¹ cycling refrigerated air dryer

2.8 controller instructions

User interface - with CAREL

2



Changing set points

General

The factory-programmed set point normally meets the nominal capacity of your dryer and is also appropriate for all the flows lower than nominal. A change of set point may be necessary to obtain a dew point higher than the standard dew point to allow flows higher than nominal capacity or in a particularly hot environment.

Adjustment

- Press the set button for one second, the digital display will show set and then the current set point will be flashing.
- Use the Up and Down arrow to modify the set point based on application requirements.

32-50°F adjustment if possible through a programming change

- To record the new value, press the SET button. The digital display panel reverts to its normal status (i.e. stops flashing) and indicates the variation between the measured value and the set point.



Modifying other parameters

Parameters access

- Press and hold SET button for 3 seconds until reach P5.
- Press the UP and DOWN arrows to scroll the list of available parameters.
- Press the SET button to show the relevant parameters value.
- Increase or decrease the parameters value by using the UP and DOWN arrows keys.
- Press the set button to memorize the parameters value and return to the parameters display.
- Follow the same procedure above to review all of the relevant parameters.
- Press and hold the set button for 3 seconds to memorize and lock in the parameters. The display will exit the parameter setting menu. Note that if this last operation of holding the set button for 3 seconds is not completed all changes to parameters will revert to previous values and modifications to parameters will not be applied.

Parameters table

| parameters | description | min | max | default | unit |
|------------|---------------------------------------|-----|-----|---------|--------|
| /4 | Select probe display ⁽¹⁾ | 1 | 3 | 1 | - |
| /C1 | Offset of probe 1 ⁽²⁾ | -50 | 50 | 0 | °F |
| Set | Set point | 28 | 39 | 35 | °F |
| P1 | Duration of auto purge | 0 | 999 | 2 | Second |
| P2 | Time interval between two auto purges | 0 | 999 | 1 | Minute |
| P3 | Short manual purge cycle | 0 | 999 | 1 | Minute |
| P4 | Long manual purge cycle | 0 | 999 | 0 | Minute |

⁽¹⁾ In NXC dryers, probe 1 is only used. Do not change this parameter.

⁽²⁾ This offset allows taking into account the effects of heat transfer between the probe and the measured environment. Do not change this parameter.



R¹ cycling refrigerated air dryer

Changing condensate drains parameters

General

- The condensate drain energizes automatically opens every one minutes (parameter p2) for a duration of two seconds (parameter p1). The factory setting matches the standard operating conditions of the dryer. However , you may have to:
- increase the duration and possibly the frequency of purging if the temperature of the air to be treated is higher than the rated value and if there is water in liquid condensate downstream of the dryer.
- decrease the duration and possibly the frequency of the condensate drain if the temperature of the air to be treated is lesser than the rated value (in the case of a water after cooler after the air compressor) or if the compressed air to be treated is not saturated with humidity (pre-drying or partial expansion).
- The objective of properly adjusting the purge duration is simply to limit the loss compressed air to the absolute minimum required for this operation. A properly adjusted purging operation is characterized by:
 - the expulsion of condensates (water/oil emulsion) for the majority of the purge time.
 - a short jet of dry compressed air without condensates at the end of the purge.

Functioning of manual purge

Short cycle:

- Press the purge icon and hold for 1 second.
- The screen displays “Sho” for the first three seconds.
- Release the button to start the short purge cycle (refer to P3 parameter).

Long cycle:

- Press the purge icon and hold for several seconds.
- The screen displays “Sho” for the first three seconds and then displays “Lon”.
- When the screen displays “Lon”, release the button to start the long purge cycle (refer to P4 parameter).

Purge Test

General

The purge needs to be tested during:

- the first commissioning,
- routine inspections,
- the depressurization of the dryer for maintenance operations.



Operating procedure

1. Press the down arrow and hold for 1 second. Check that the solenoid valve opens and that the condensate drain away. Check that the purge icon is illuminated on the controller interface.
2. The solenoid valve closes and the purging of the condensate stops.
3. Wait for 5 minutes and re-check that draining is carried out correctly.
4. If necessary, change the condensate drain duration referring to §5.4 section.

2

2.9 safety system

The dryer has a safety system which disconnects the device when triggered.

Electrical circuit

The motor protection allows disconnecting the dryer through the thermal relay when the air compressor operates under overload.

Restart

1. Resolve the problem that caused the device to shut down (refer to corrective maintenance, or contact **nano-purification solutions**).
2. Press the start button to restart the dryer.

2.10 routine maintenance

Daily maintenance

- Check that the drain normally evacuates the water and compressed air.
- Check that there are no air leaks on the inlet and outlet connections.
- Verify the temperature of the compressed air at the inlet and the ambient temperature are within operating parameters of the dryer specification.
- Clean the condenser of the dryer at regular intervals (once every two weeks).

Maintenance

Clean the condenser regularly using a vacuum cleaner, brush or a compressed air gun. An improper heat efficiency of the exchanger and the shut-down of the dryer due to the triggering of the safety system following a serious malfunction will impact the functioning of the condenser.

❖ **Ensure that the blades and the thin aluminum plate of the condenser do not get bent out of shape while cleaning.**





R¹ cycling refrigerated air dryer

Condensate drain, strainer maintenance

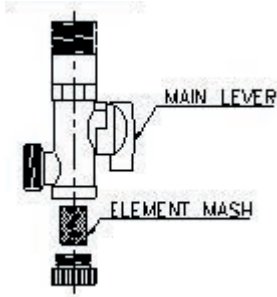

The locally installed strainer on the condensate drain helps to trap dirt. It is necessary to clean the Y-strainer depending on the quantity of the dirt present in the system to ensure proper operation. All our models from NXC 0020 are equipped with this Y-strainer.

2

2.11 trouble shooting in the event of malfunction

At normal working conditions, check the pressure gauge of the dryer as:

1. R-134a

Below 27 psi: Refill refrigeration gas if there is insufficient volume (check for any leakage).
Above 60 psi: Remove a certain volume of refrigeration gas if there is excessive volume (due to ambient temperature and air inlet temperature, because pressure increases if temperature is high).

2. R-407c

Below 60 psi Refill refrigeration gas if there is insufficient volume (check for any leakage).
Above 140 psi: Remove a certain volume of refrigeration gas if there is excessive volume (due to ambient temperature and air inlet temperature, because pressure increases if temperature is high).



Important!

The pointer of the pressure gauge can go out of the normal working range if there are defects in other parts of the device. The settings must be adjusted properly. Consult nano-purification solutions or a qualified refrigeration technician for assistance.

Refrigerant handling in the US and Canada is only permitted by technicians with a valid refrigeration license.



When contacting your service provider be sure to provide the part number and serial number of your dryer, this can be found on the rating plate.



2.12 maintenance



Various risks (electrocution, explosion...): The following operations must only be carried out by personnel qualified in electrical and pneumatic systems.

| frequency of maintenance | daily | monthly | 6 months | year 1 (12 months) |
|--|-------|---------|----------|-----------------------|
| Check for alarm messages. | ✓ | | | |
| Test the drain. | ✓ | | | |
| Test the compressed air inlet temperature and compare to the maximum value on the manufacturer's plate. | | ✓ | | |
| Clean the solenoid drain valve*. | | ✓ | | |
| Check that the temperature of the ambient air complies with minimum and maximum values shown on the manufacturer's plate. Check that the room is well ventilated. | | ✓ | | |
| Check that when operating the temperature of the upper part of the compressor is not too high (122°F Max). Test that the current consumed by the dryer complies with values on the manufacturer's plate. | | | ✓ | |
| Clean the solenoid drain valve*. | | | ✓ | |
| Visually inspect the refrigeration circuit, the state of pipework and look for oil slicks which can indicate a loss of refrigerant gas* pressure. | | | ✓ | |
| Test the pipework connections. | | | ✓ | |
| Test the condition of the electrical contacts and connections*. | | | ✓ | |
| Check that the fan is not noisy. | | | ✓ | |
| Clean the condensing unit fins with a sponge or a clean compressed air jet. Check that the grids are not dirty or clogged*. | | | ✓ | |
| Clean the condensing unit fins with a non-aggressive detergent*. | | | | ✓ |

Important:

- This schedule is based on average operating conditions. In some cases, it may be necessary to increase maintenance frequency.
- Clean the condensate strainer on the drain system 1 week after start-up.

*You must comply with the recommendations at the beginning of this chapter.





R¹ cycling refrigerated air dryer

Shutdown and isolate from network



Various risks (flying objects, explosion, noise, electrocution...): Always turn off all circuits before working on the dryer. Follow the procedure below:

1. Open the by-pass valve.
2. Close the upstream valve.
3. Close the downstream valve.
4. Press the up arrow's button for stop the dryer.
5. Depressurize the dryer by pressing the drain manual override until internal pressure is zero.

2

Access inside the dryer



Various risks (electrocution, explosion)

- Lock the power supply cut-out switches OPEN.
- Lock the upstream and downstream valves CLOSED and the by-pass valve OPEN.
- Depressurize the dryer by pressing the drain manual override until internal pressure is zero.

After carrying out the three procedures above, proceed as specified below for your dryer model.

NXC 0020 to NXC 0045

- Unscrew and withdraw the lower screws of the front panel and slide it upwards to release the lock tabs. Take off the front panel.

NXC 0065 to NXC 2000

- Unscrew and withdraw the back screws of the upper panel and slide it backwards to release the lock tabs. Take off the upper panel.
- Otherwise, unscrew and withdraw the lower screws of the front panel and slide it upwards to release the lock tabs. Take off the front panel.

You can now work inside the dryer risk-free.



R¹ cycling refrigerated air dryer



Closing



Various risks (electrocution, explosion)

After maintenance, proceed as specified below for your appliance model.

NXC 0020 to NXC 0045

1. Replace the front panel by sliding it downwards to engage the lock tabs. Screw in the lower screws of the front panel.

NXC 0065 to NXC 2000

1. Replace the upper panel by sliding it forwards to engage the lock tabs. Screw in the rear screws of the upper panel. Otherwise, replace the front panel by sliding it downwards to engage the lock tabs. Screw in the lower screws of the front panel.

Then

2. Unlock the power supply cut-out switches.
3. Unlock the upstream and downstream valves and the by-pass valve.

You can now start up the dryer and return it to the network

2





R¹ cycling refrigerated air dryer

Components internal layout

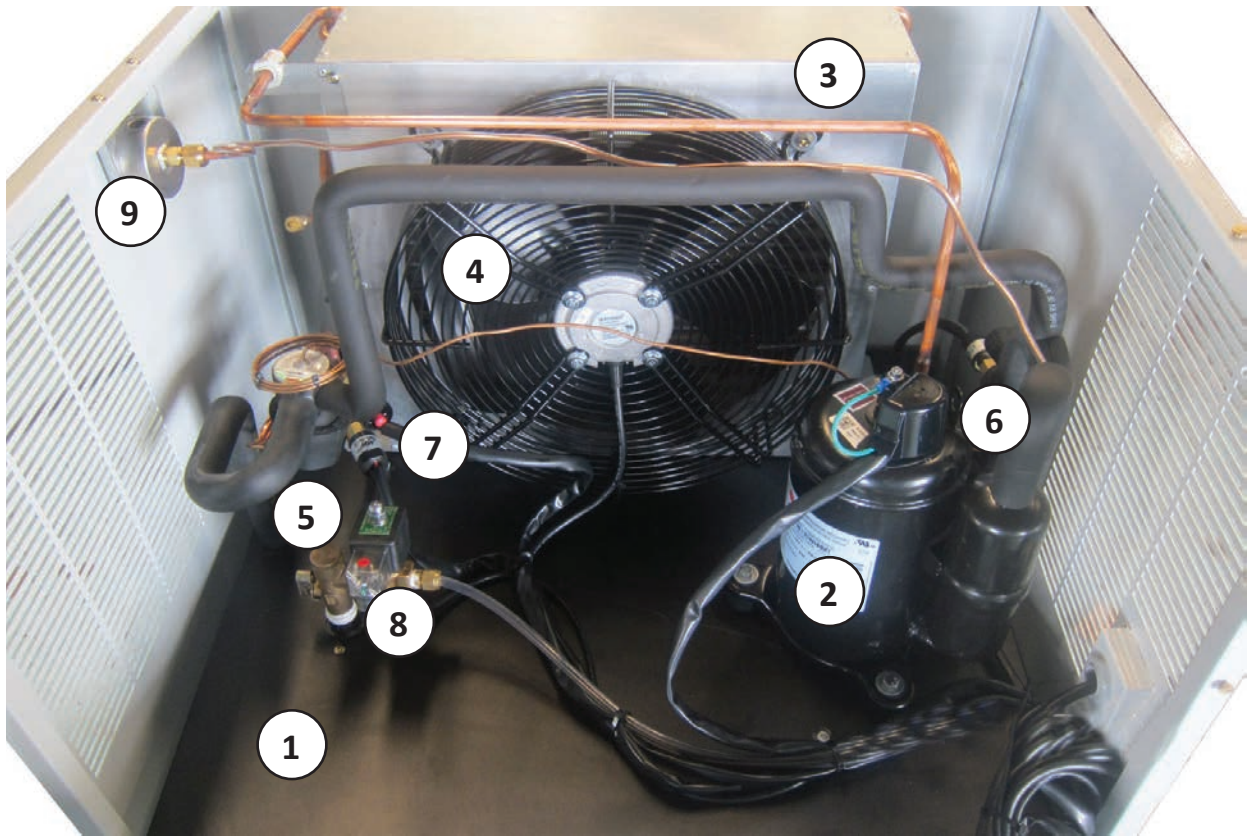

| no | description | no | description |
|----|---------------------|----|----------------------|
| 1 | thermal mass | 6 | low pressure switch |
| 2 | compressor | 7 | high pressure switch |
| 3 | condenser | 8 | drain solenoid valve |
| 4 | condenser fan | 9 | pressure gauge |
| 5 | fan pressure switch | 10 | controller |



Cleaning the drain Y-strainer*

General comments

The solenoid drain is protected by a strainer to prevent damage to the solenoid valve seals from metal particles or dust. This strainer must be cleaned 1 week after the first start-up and then once per month. If this is not done, the strainer will clog and it will not be possible to purge the system correctly. Liquid phase water will appear in the compressed air network.

Procedure

1. Close the manual valve on the purge (see the refrigeration/pneumatic circuit diagram).
2. Unscrew the strainer lock nut.
3. Withdraw the metal mesh, clean and refit.
4. Check the condition of the seal and replace if necessary.
5. Tighten the strainer lock nut.
6. Open the manual valve on the purge line.

**You must comply with the recommendations at the beginning of this chapter.*

Solenoid valve maintenance*

The solenoid valve must always be protected by a filter to ensure that solid particles do not prevent it from opening and closing correctly. If particles do get through the filter and cause faulty operation of the solenoid purge valve, it must be dismantled and cleaned.

Procedure

1. Close the manual valve on the purge line (see refrigeration/pneumatic circuit diagram).
2. Disconnect the solenoid valve power supply.
3. Disconnect the solenoid valve from the pipework and clamp it in a vice.
4. Unscrew the coil lock nut and take it off the plunger.
5. Unscrew the plunger from the valve seat.
6. Check the O ring and the other components. Clean carefully.
7. Re-assemble the valve by reversing operations 1 to 5.

Do not over tighten the coil lock nut as this could prevent the valve from closing.

8. Refit the solenoid valve to the pipework, respecting the direction of the air flow indicated by an arrow on the body.
9. Reconnect the power supply to the solenoid purge valve.
10. Open the manual valve on the purge line

**You must comply with the recommendations at the beginning of this chapter.*





R¹ cycling refrigerated air dryer

2.13 trouble shooting

2

| problem | cause | symptom | solution |
|--|---|---|---|
| A. Dew point too high | Compressed air temperature too high | The digital display panel indicates a value > 50°F permanently. | Return the air inlet temperature to within the limits. |
| | Compressed air flow rate too high | Same as above | Correct the air flow rate to within the limits of the dryer. |
| | Compressed air pressure too low | Same as above | Correct the pressure to within the limits. |
| | Ambient temperature too high | Same as above | Correct the temperature to within the limits. (R134a unit, limit is 122°F, R407c unit, limit is 110°F) |
| | Dirty fins of the condenser | Same as above | Clean the condensing unit fins. |
| | Condensing unit face clogged | Same as above | Clean the condensing unit face. |
| | The fan runs backwards (three-phase) | Same as above | Correct electrical connection (phase inversion) |
| | Refrigerant gas leak | The compressor runs all the time. The compressor top is very hot. | Find the leak and repair it. |
| The HP pressure switch has tripped. | The digital display panel is OFF. | See note E. | |
| B. Excessive drop in compressed air pressure | Compressed air flow rate too high | Pressure downstream from the dryer lower than the expected value. | Reduce the compressed air flow rate. |
| | Condensate frozen | Pressure downstream from the dryer lower than the expected value. | See note C. |
| | Exchanger Tubes soiled by impurities in the compressed air. | Pressure downstream from the dryer lower than the expected value. | Wash the heat exchanger tubes with a non-aggressive detergent solution. Check the filter upstream from the dryer. |
| C. Compressed air does not flow through the dryer. | The condensates have frozen and block the passage as the probe is incorrectly positioned. | Compressed air does not flow through the dryer. | Position the probe in the center of the DTM heat exchanger. |
| | The condensate have frozen and block the passage as the set point is programmed too low. | After the starting the compressor, value 0 is reached in less than 2 minutes. | Increase the set point value. |
| | The condensate have frozen and block the passage as the electronic controller has failed. | The compressor stops. The compressor does not stop even if the Carel indicates 0 several minutes. | See note H. Change the Carel. |



cycling refrigerated air dryer



| problem | cause | symptom | solution |
|---|---|---|---|
| D. Condensate present downstream from the dryer | The solenoid valve coil has failed. | No condensates or air are expelled when the down button is pressed. | Replace the solenoid valve coil. |
| | The purge circuit is clogged. | The purge filter is dirty. | Clean the filter. |
| | The solenoid purge valve opening time is insufficiently long time. | No condensate or air are expelled when the purge button is pressed. | Increase the duration for which the solenoid purge valve opens. |
| | Solenoid valve plug clogged | No condensate or air are expelled when the purge button is pressed. | Clean the solenoid valve. |
| | The relay on the Carel which controls the solenoid valve does not function. | Use a voltmeter to check if the relay contacts do not close when the purge button is pressed. | Replace the electronic board if the relay does not function. |
| | Distribution network pipework is in a "cold" environment in which the temperature is lower than the dew point temperature of the compressed air under pressure and the tubes are not lagged. In this case, condensate form on the internal surfaces of the pipes. | The dryer functions problem-free. The cause of the problem is external. | Lag the pipework in "cold" environments. |
| E. HP pressure switchcuts in (manual) | The motorized fan does not function. | The Carel's regulator is OFF as if the power supply had failed. | Repair or replace the fan. Press the red re-set button on the pressure controller. |
| | Ambient temperature too high. | Ambient air temperature conditions higher than maximum authorized value | Return the ambient temperature to within the limits by, for example, increasing room ventilation. Press the red re-set button on the pressure controller. |
| | Recirculation of hot air due to incorrect installation. | Very high temperature in room | Modify the position of the machine or the obstructions to eliminate air recirculation. Press the red re-set button on the pressure controller. |
| | Condensing unit fins dirty. | The digital display panel continuously indicates a value > 39.2°F. | Clean the condensing unit fins. Press the red re-set button on the pressure controller. |
| | Condensing unit grill clogged. | The digital display panel indicates a value > 39.2°F continuously | Clean the condensing unit front face. Press the red re-set button on the pressure controller. |
| | Relatively high ambient air Temperature and fan turning in wrong direction (if three-phase power supply). | Cooling air passes first passes through the fan and then through the condensing unit. | Reverse two machine power supply phases. Press the red re-set button on the pressure controller. |
| | Compressed air flow rate or temperature too high and high ambient temperatures at the same time. | High dew point (which means a high evaporation pressure of raised and higher purging from the separator). | Correct the temperature and the air flow to pre-set limits. Press the red button on the Pressure switch cap. |





R¹ cycling refrigerated air dryer

2

| problem | cause | symptom | solution |
|--|---|---|--|
| F. Low pressure (LP) Pressure switch cuts in.(auto.) | Refrigerant leak | The compressor stops before cooling the thermal mass to the pre-set value or compressor stop and start many times. | Have the circuit checked for leaks by a refrigeration technician and eliminate them. Have a refrigeration technician Refill the circuit. After each LP switch cut, no display during 2 minutes and compressor start automatically 2 minutes after. |
| | On first start-up if the ambient temperature is too low and the thermal mass is at the same temperature as the ambient temperature. | Same as above | Correct the ambient temperature by raising it above the minimum set point value. |
| G. Compressor protection system cuts in | Compressed air flow rate and temperature too high and high ambient temperature at the same time. | <ul style="list-style-type: none"> •The compressor head and body are very hot. •The compressor stops and tries to start up again a few seconds later. | Shut the compressor down and adjust compressed air flow rate and pressure to within the dryer limits. Wait a few minutes before starting up the compressor again Check and replace the HP Pressure switch if necessary. |
| | Compressed air flow rate and temperature too high and refrigerating circuit empty. | <ul style="list-style-type: none"> •The compressor head and body are very hot. •The compressor stops and tries to start up again a few seconds later. | Have the circuit checked for leaks by a refrigeration technician, refill the circuit. Check and replace the HP Pressure switch if necessary. |
| | The HP Pressure switch has failed. | Same as above | Check and replace the HP Pressure switch if necessary. |
| E. Sensor protection system cuts in | The compressor has stopped the control board display show 00 and the first digit point is blinking. | The temperature sensor is not connected or short circuited. | |



R¹

cycling refrigerated air dryer



3.1 arrangement drawings

NXC 0020 to NXC 0045

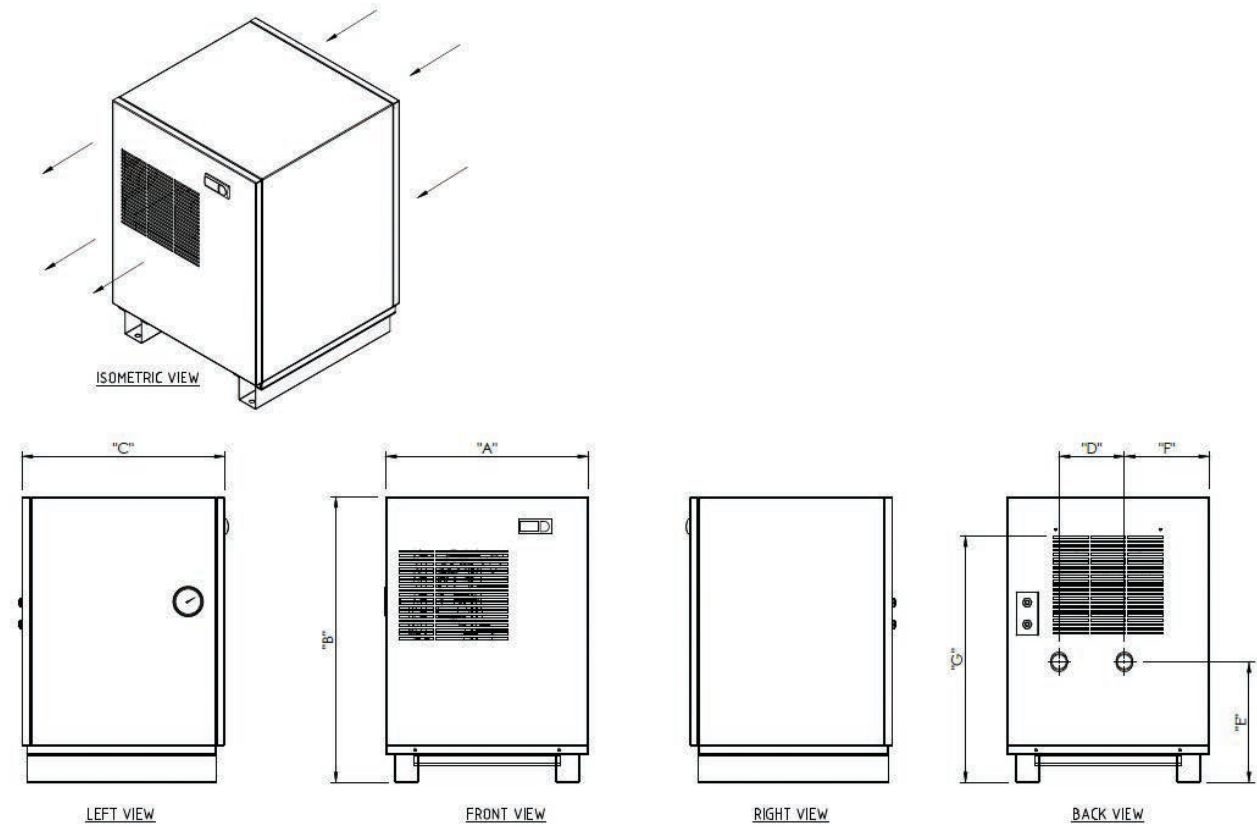

3



dimensions

| model | A | | B | | C | | D | | E | | F | | G | |
|----------|-------|-----|-------|-----|-------|-----|------|-----|-------|-----|------|-----|-------|-----|
| | in | mm | in | mm | in | mm | in | mm | in | mm | in | mm | in | mm |
| NXC 0020 | 16.93 | 430 | 22.24 | 565 | 15.98 | 406 | 7.80 | 198 | 9.41 | 239 | 4.57 | 116 | 20.67 | 525 |
| NXC 0030 | 18.19 | 462 | 25.79 | 655 | 18.39 | 467 | 5.91 | 150 | 10.91 | 277 | 7.68 | 195 | 22.24 | 565 |
| NXC 0045 | 18.19 | 462 | 25.79 | 655 | 18.39 | 467 | 5.91 | 150 | 10.91 | 277 | 7.68 | 195 | 22.24 | 565 |



R¹ cycling refrigerated air dryer

NXC 0065 to NXC 0400

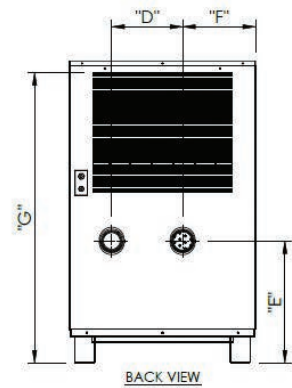
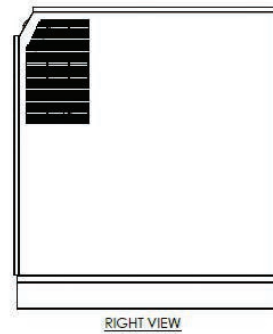
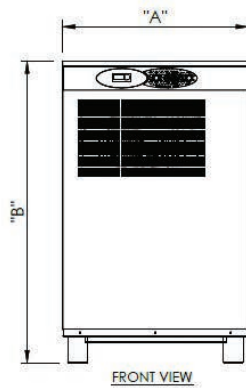
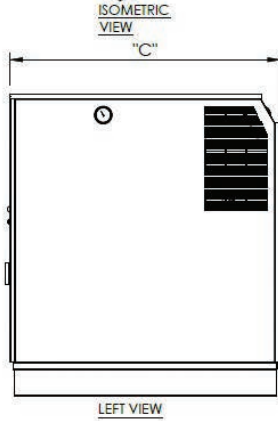
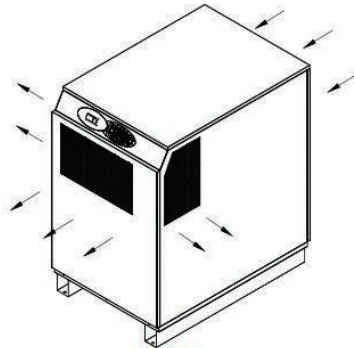

dimensions

| model | A | | B | | C | | D | | E | | F | | G | |
|----------|-------|-----|-------|-----|-------|-----|-------|-----|-------|-----|-------|-----|-------|-----|
| | in | mm | in | mm | in | mm | in | mm | in | mm | in | mm | in | mm |
| NXC 0065 | 22.64 | 575 | 30.20 | 767 | 21.26 | 540 | 9.92 | 252 | 12.83 | 326 | 6.34 | 161 | 28.56 | 726 |
| NXC 0090 | 22.64 | 575 | 30.20 | 767 | 21.26 | 540 | 9.92 | 252 | 12.83 | 326 | 6.34 | 161 | 28.56 | 726 |
| NXC 0110 | 22.64 | 575 | 30.20 | 767 | 21.26 | 540 | 9.92 | 252 | 12.83 | 326 | 6.34 | 161 | 28.56 | 726 |
| NXC 0130 | 29.13 | 740 | 36.46 | 926 | 24.33 | 618 | 10.24 | 260 | 15.71 | 399 | 11.08 | 282 | 34.57 | 878 |
| NXC 0165 | 29.13 | 740 | 36.46 | 926 | 24.33 | 618 | 10.24 | 260 | 15.71 | 399 | 11.08 | 282 | 34.57 | 878 |
| NXC 0200 | 29.13 | 740 | 38.66 | 982 | 29.92 | 760 | 11.42 | 290 | 17.20 | 437 | 11.50 | 292 | 36.89 | 937 |
| NXC 0265 | 29.13 | 740 | 38.66 | 982 | 29.92 | 760 | 11.42 | 290 | 17.20 | 437 | 11.50 | 292 | 36.89 | 937 |
| NXC 0325 | 29.13 | 740 | 38.66 | 982 | 29.92 | 760 | 11.42 | 290 | 17.20 | 437 | 11.50 | 292 | 36.89 | 937 |
| NXC 0400 | 29.13 | 740 | 38.66 | 982 | 29.92 | 760 | 11.42 | 290 | 17.20 | 437 | 11.50 | 292 | 36.89 | 937 |

R¹ cycling refrigerated air dryer



NXC 0500

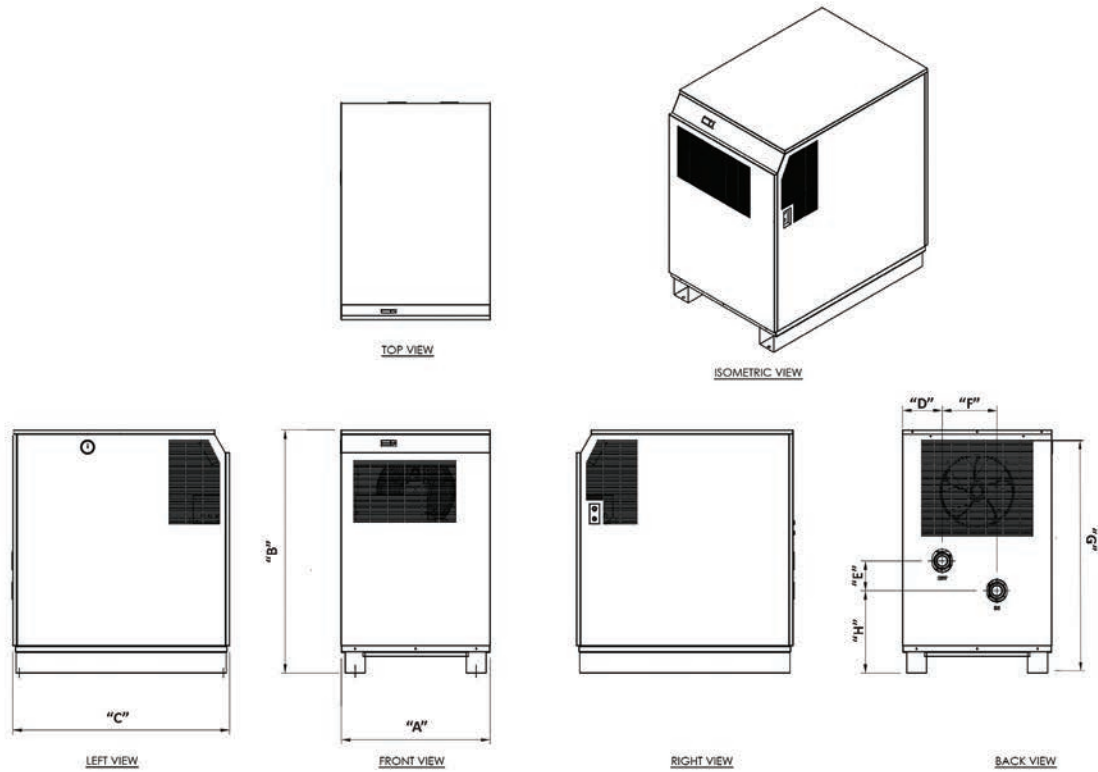

3



dimensions

| model | A | | B | | C | | D | | E | | F | | G | | H | |
|----------|------|-----|------|------|------|------|-----|-----|-----|-----|------|-----|------|------|------|-------|
| | in | mm | in | mm | in | mm | in | mm | in | mm | in | mm | in | mm | in | mm |
| NXC 0500 | 29.0 | 736 | 47.3 | 1202 | 42.3 | 1074 | 7.8 | 197 | 5.8 | 148 | 10.7 | 271 | 45.5 | 1156 | 16.0 | 407.6 |



R¹ cycling refrigerated air dryer

NXC 0650 to NXC 0850

3

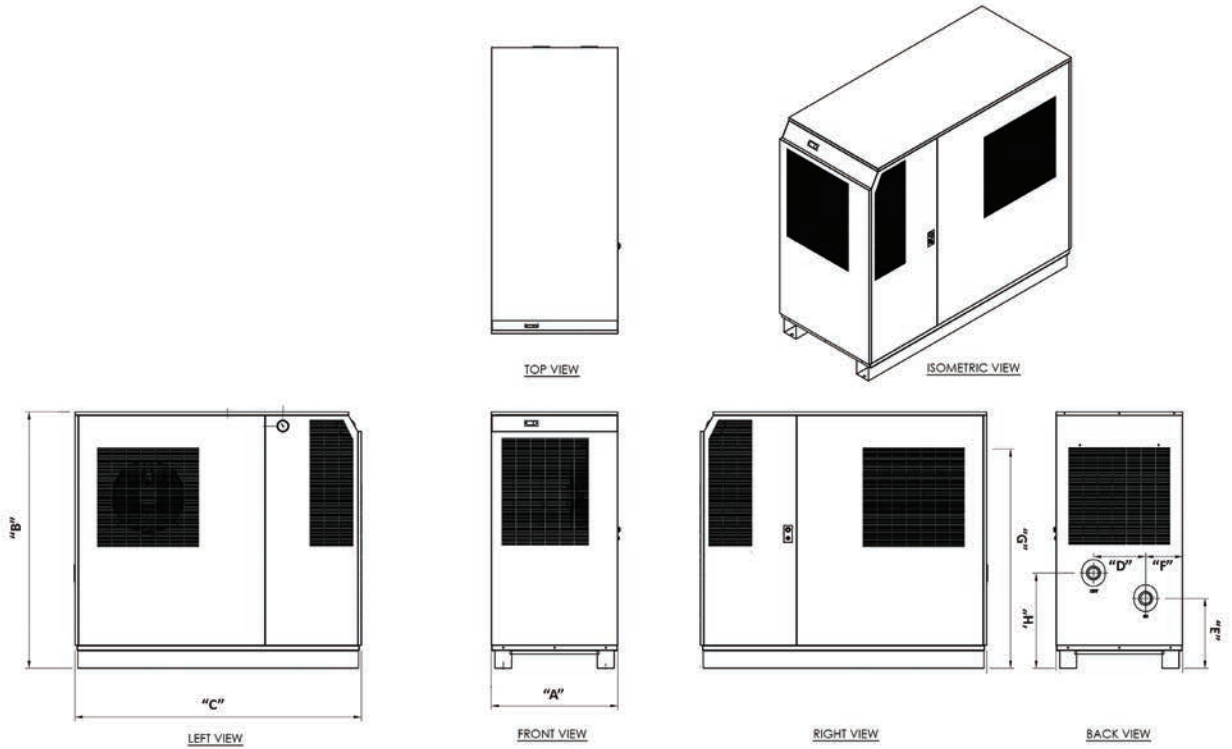

dimensions

| model | A | | B | | C | | D | | E | | F | | G | | H | |
|----------|------|-----|------|------|------|------|------|-----|------|-----|-----|-----|------|------|------|-----|
| | in | mm | in | mm | in | mm | in | mm | in | mm | in | mm | in | mm | in | mm |
| NXC 0650 | 29.1 | 740 | 59.1 | 1500 | 65.9 | 1674 | 12.0 | 305 | 16.1 | 408 | 8.5 | 216 | 50.8 | 1290 | 21.9 | 556 |
| NXC 0850 | 29.1 | 740 | 59.1 | 1500 | 65.9 | 1674 | 12.0 | 305 | 16.1 | 408 | 8.5 | 216 | 50.8 | 1290 | 21.9 | 556 |

R¹

cycling refrigerated air dryer



NXC 1050 to NXC 1300

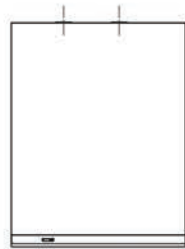

TOP VIEW

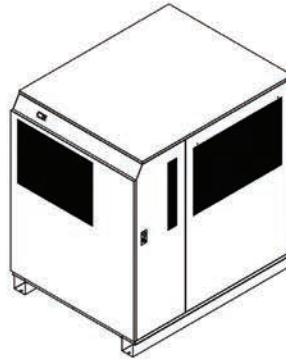

ISOMETRIC VIEW

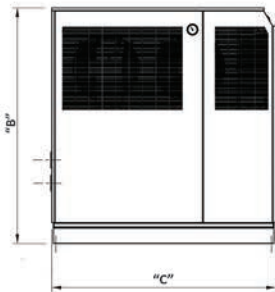

LEFT VIEW

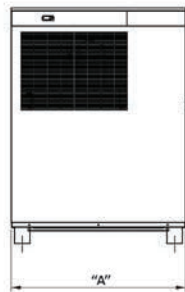

FRONT VIEW



RIGHT VIEW

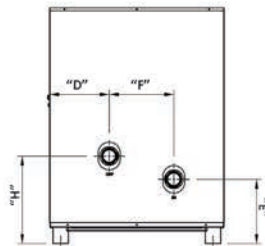

BACK VIEW

dimensions

| model | A | | B | | C | | D | | E | | F | | G | | H | |
|----------|------|------|------|------|------|------|------|-------|------|-------|------|-----|----|------|------|-------|
| | in | mm | in | mm | in | mm | in | mm | in | mm | in | mm | in | mm | in | mm |
| NXC 1050 | 43.7 | 1110 | 59.1 | 1500 | 56.1 | 1425 | 14.9 | 379.5 | 16.1 | 408.5 | 16.2 | 411 | 55 | 1397 | 21.9 | 556.5 |
| NXC 1300 | 43.7 | 1110 | 59.1 | 1500 | 56.1 | 1425 | 14.9 | 379.5 | 16.1 | 408.5 | 16.2 | 411 | 55 | 1397 | 21.9 | 556.5 |

3





R¹ cycling refrigerated air dryer

NXC 1600 to NXC 2000

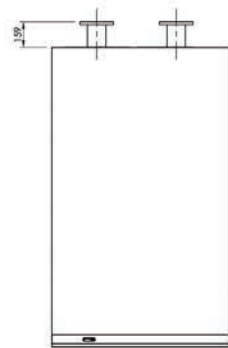

TOP VIEW

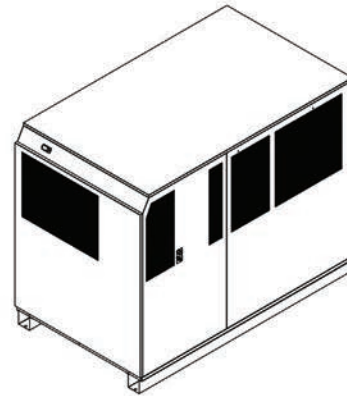

ISOMETRIC VIEW

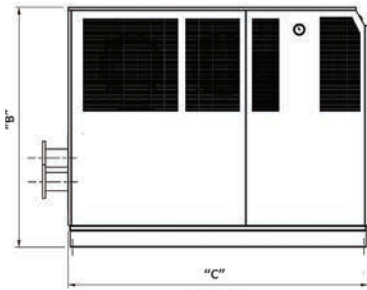

LEFT VIEW

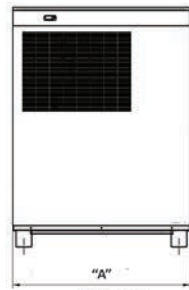

FRONT VIEW

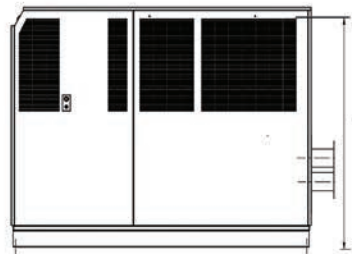

RIGHT VIEW

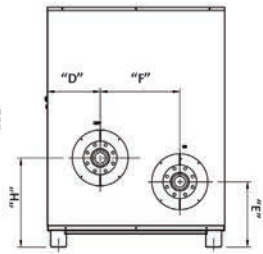

BACK VIEW

dimensions

| model | A | | B | | C | | D | | E | | F | | G | | H | |
|----------|------|------|------|------|------|------|------|-------|------|-------|------|-----|------|--------|------|-------|
| | in | mm | in | mm | in | mm | in | mm | in | mm | in | mm | in | mm | in | mm |
| NXC 1600 | 43.7 | 1110 | 59.1 | 1500 | 73.8 | 1875 | 13.1 | 331.5 | 16.1 | 408.5 | 19.6 | 497 | 56.5 | 1435.1 | 21.9 | 556.5 |
| NXC 2000 | 43.7 | 1110 | 59.1 | 1500 | 73.8 | 1875 | 13.1 | 331.5 | 16.1 | 408.5 | 19.6 | 497 | 56.5 | 1435.1 | 21.9 | 556.5 |



3.2 exploded views and spare parts

Exploded views are presented only by chassis/cabinet and not by each model. Some parts are similar between two models of one chassis/cabinet, some others are different. These views are provided for part identification purposes only. When contacting nano-purification solutions for support, please have the serial number and model of your dryer available.

nano-purification solutions is committed in continuous performance improvement and some parts are subject to change without prior notice.

NXC 0020 - 115/60/1

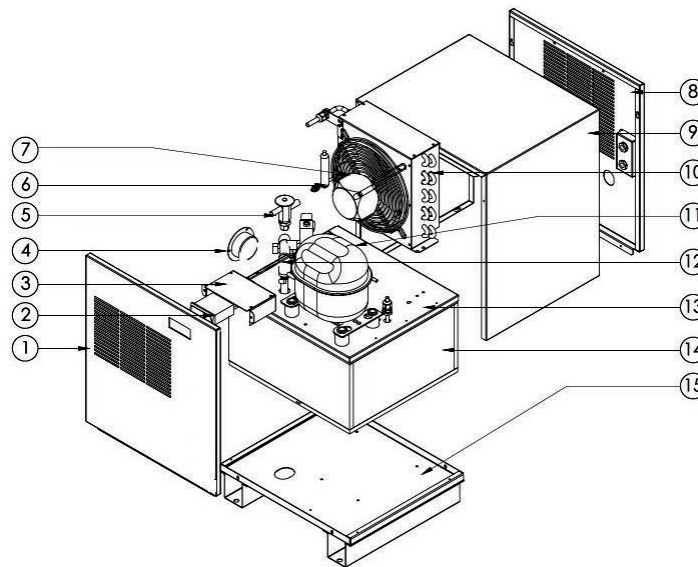

| no | description | part no | no | description | part no |
|----|--------------------------|---------------|----|----------------------------------|---------------|
| 1 | front panel | NXC0020-1-301 | 10 | air cooled condenser | SC400-MAST05 |
| 2 | controller | C0104-220N | 11 | refrigerant compressor | A0101-015N |
| 3 | control board cover | NXC0020-1-302 | 12 | condensate solenoid drain | A0904-088N |
| 4 | suction pressure gauge | A1102-040N | 13 | middle partition plate | NXC0020-1-901 |
| 5 | expansion valve (SAV-05) | A1001-139N | 14 | evaporator | * |
| 6 | refrigerant filter | A1001-087N | 15 | bottom base assembly | NXC0020-1-100 |
| 7 | condenser fan motor | A0601-032N | | NTC dew point temperature sensor | C0104-221N |
| 8 | back panel assembly | NXC0020-1-500 | | condensate y-strainer | A2001-028N |
| 9 | top panel | NXC0020-1-701 | | | |

*contact support@n-psi.com for any part number not listed





R¹ cycling refrigerated air dryer

NXC 0030 to NXC 0045 - 115/60/1

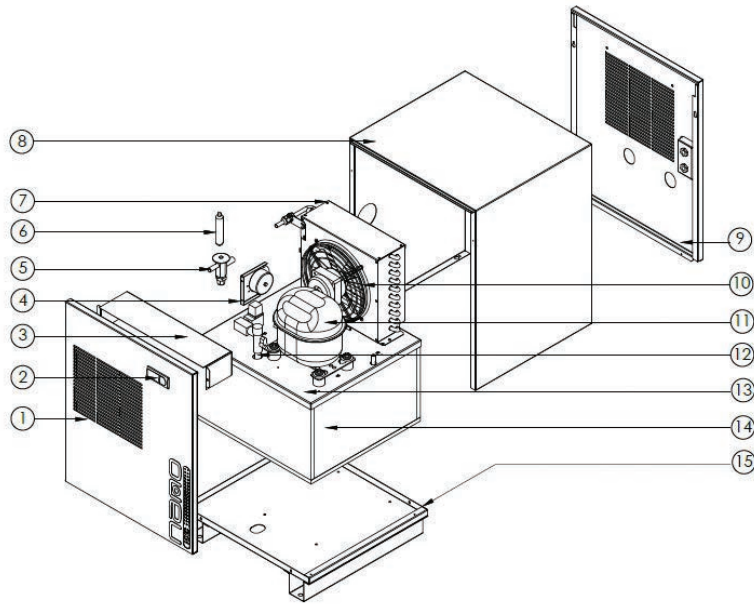

| no | description | part no | no | description | part no |
|----|--------------------------|---------------|----|----------------------------------|---------------|
| 1 | front panel | NXC0030-1-301 | 11 | refrigerant compressor | A0101-016N |
| 2 | controller | C0104-220N | 12 | condensate solenoid drain | A0904-088N |
| 3 | control board cover | NXC0030-1-302 | 13 | middle partition plate | NXC0030-1-901 |
| 4 | suction pressure gauge | A1102-040N | 14 | evaporator (NXC 0030) | * |
| 5 | expansion valve (SAV-05) | A1001-139N | | evaporator (NXC 0045) | * |
| 6 | refrigerant filter | A1001-087N | 15 | bottom base assembly | NXC0030-1-100 |
| 7 | air cooled condenser | SC400-MAST00 | | NTC dew point temperature sensor | C0104-221N |
| 8 | top panel | NXC0030-1-701 | | condensate y-strainer | A2001-028N |
| 9 | back panel assembly | NXC0030-1-500 | | | |
| 10 | condenser fan motor | A0601-32N | | | |

*contact support@n-psi.com for any part number not listed

R¹

cycling refrigerated air dryer



NXC 0065 to NXC 0110 - 115/60/1

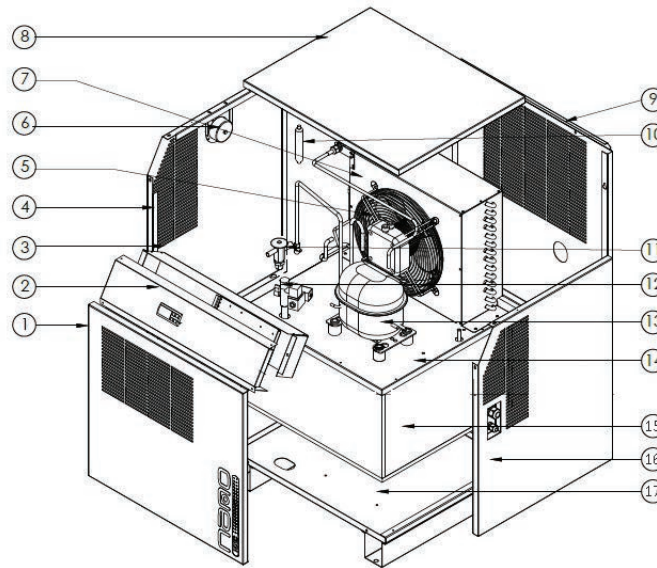

3

| no | description | part no | no | description | part no |
|----|--------------------------|---------------|----|----------------------------------|---------------|
| 1 | front panel | NXC0065-1-301 | 12 | condensate solenoid drain | A0904-088N |
| 2 | controller | C0104-220N | 13 | refrigerant compressor | A0101-018N |
| 3 | control board cover | NXC0065-1-303 | 14 | middle partition plate | NXC0065-1-901 |
| 4 | side panel left | NXC0065-1-601 | 15 | evaporator (NXC 0065) | * |
| 5 | condenser fan motor | A0601-033N | | evaporator (NXC 0090) | * |
| 6 | suction pressure gauge | A1102-040N | | evaporator (NXC 0110) | * |
| 7 | air cooled condenser | SC400-MAST01 | 16 | side panel right | NXC0065-1-401 |
| 8 | top panel | NXC0065-1-701 | 17 | bottom base assembly | NXC0065-1-100 |
| 9 | back panel assembly | NXC0065-1-500 | | NTC dew point temperature sensor | C0104-221N |
| 10 | refrigerant filter | A1001-090N | | condensate y-strainer | A2001-028N |
| 11 | expansion valve (SAV-05) | A1001-139N | | control panel | NXC0065-1-302 |

*contact support@n-psi.com for any part number not listed





R¹ cycling refrigerated air dryer

NXC 0130 to NXC 0165 - 115/60/1

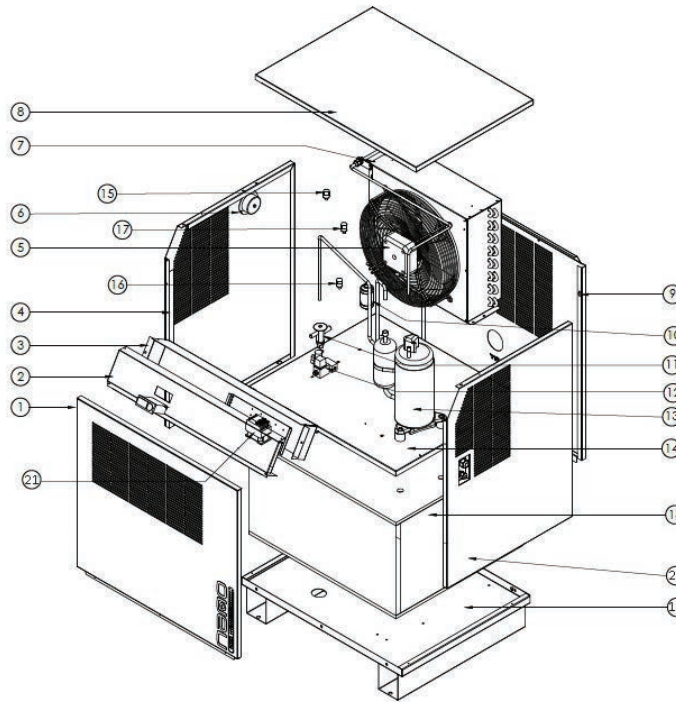

| no | description | part no | no | description | part no |
|----|---------------------------|---------------|----|----------------------------------|---------------|
| 1 | front panel | NXC0130-1-301 | 14 | middle partition plate | NXC0130-1-901 |
| 2 | controller | C0104-220N | 15 | high pressure switch | A0802-053N |
| 3 | control board cover | NXC0130-1-303 | 16 | low pressure switch | A0802-061N |
| 4 | side panel left | NXC0130-1-601 | 17 | fan pressure switch | A0802-054N |
| 5 | condenser fan motor | A0702-043N | 18 | evaporator (NXC 0130) | * |
| 6 | suction pressure gauge | A1102-040N | | evaporator (NXC 0165) | * |
| 7 | air cooled condenser | SC400-MAST02 | 19 | bottom base assembly | NXC0130-1-100 |
| 8 | top panel | NXC0130-1-701 | 20 | side panel right | NXC0130-1-401 |
| 9 | back panel assembly | NXC0130-1-500 | 21 | compressor contactor | C0108-007N |
| 10 | refrigerant filter | A1001-090N | | NTC dew point temperature sensor | C0104-221N |
| 11 | expansion valve (SAV-10) | A1001-140N | | condensate y-strainer | A2001-028N |
| 12 | condensate solenoid drain | A0904-088N | | control panel | NXC0130-1-302 |
| 13 | refrigerant compressor | A0101-043N | | | |

*contact support@n-psi.com for any part number not listed

R¹ cycling refrigerated air dryer



NXC 0200 to NXC 0400 - 230/60/1

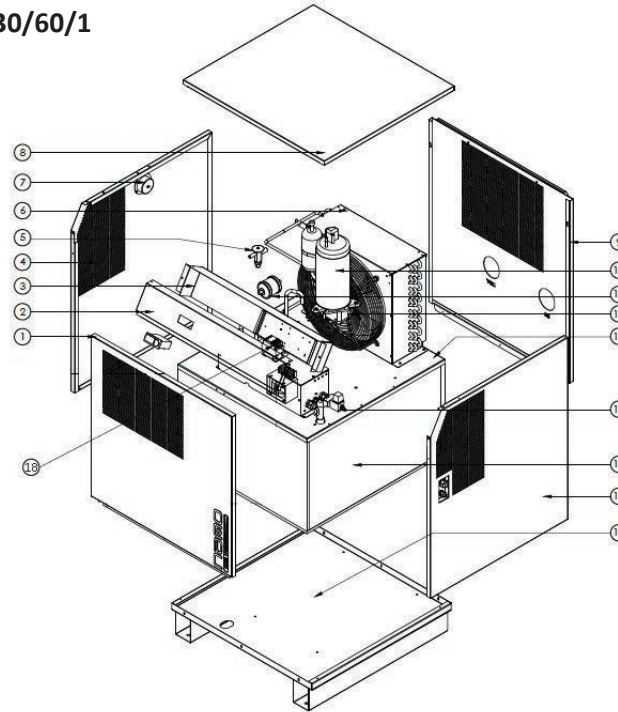

3

| no | description | part no | no | description | part no |
|----|---------------------------|---------------|----|----------------------------------|---------------|
| 1 | front panel | NXC0200-1-301 | 15 | evaporator (NXC 0200) | * |
| 2 | controller | C0104-144N | | evaporator (NXC 0265) | * |
| 3 | control board cover | NXC0200-1-303 | | evaporator (NXC 0325) | * |
| 4 | side panel left | NXC0200-1-601 | | evaporator (NXC 0400) | * |
| 5 | expansion valve | A1001-141N | 16 | side panel right | NXC0200-1-401 |
| 6 | air cooled condenser | SC400-MAST03 | 17 | bottom base assembly | NXC0200-1-100 |
| 7 | suction pressure gauge | A1102-040N | 18 | compressor contactor | C0108-007N |
| 8 | top panel | NXC0200-1-701 | | low pressure switch | A0802-061N |
| 9 | back panel assembly | NXC0200-1-500 | | high pressure switch | A0802-053N |
| 10 | refrigerant compressor | A0101-044N | | fan pressure switch | A0802-054N |
| 11 | refrigerant filter | A1001-008N | | NTC dew point temperature sensor | C0104-143N |
| 12 | condenser fan motor | A0702-044N | | condensate y-strainer | A2001-028N |
| 13 | middle partition plate | NXC0200-1-901 | | control panel | NXC0200-1-302 |
| 14 | condensate solenoid drain | A0904-089N | | | |





R¹ cycling refrigerated air dryer

NXC 0200 to NXC 0400 - 460/60/3

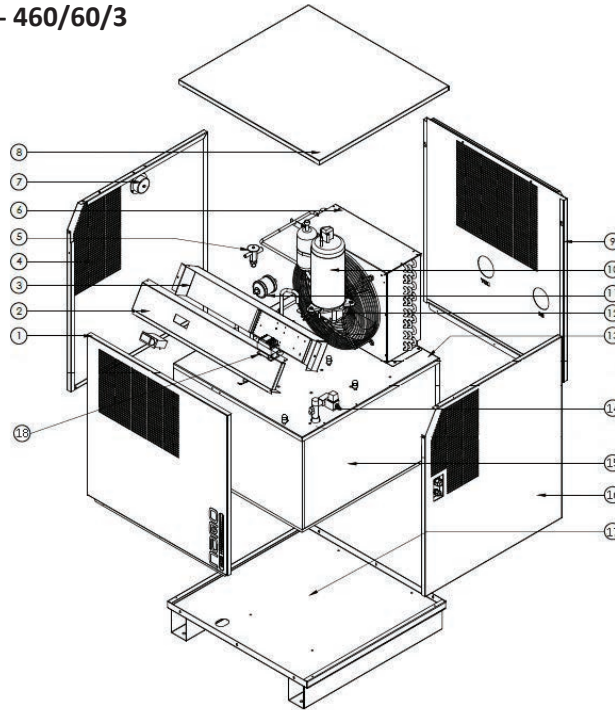

| no | description | part no | no | description | part no |
|----|------------------------|---------------|----|----------------------------------|---------------|
| 1 | front panel | NXC0200-1-301 | 14 | condensate solenoid drain | A0904-089N |
| 2 | controller | C0104-144N | 15 | evaporator (NXC 0200) | * |
| 3 | control board cover | NXC0200-1-303 | | evaporator (NXC 0265) | * |
| 4 | side panel left | NXC0200-1-601 | | evaporator (NXC 0325) | * |
| 5 | expansion valve | A1001-143N | | evaporator (NXC 0400) | * |
| 6 | air cooled condenser | SC400-MAST03 | 16 | side panel right | NXC0200-1-401 |
| 7 | suction pressure gauge | A1102-040N | 17 | bottom base assembly | NXC0200-1-100 |
| 8 | top panel | NXC0200-1-701 | 18 | compressor contactor | C0108-027N |
| 9 | back panel assembly | NXC0200-1-500 | | NTC dew point temperature sensor | C0104-143N |
| 10 | refrigerant compressor | A0101-046N | | transformer (460V/230V) | C0109-031N |
| 11 | refrigerant filter | A1001-008N | | condensate y-strainer | A2001-028N |
| 12 | condenser fan motor | A0601-045N | | control panel | NXC0200-1-302 |
| 13 | middle partition plate | NXC0200-1-901 | | | |

3



R¹ cycling refrigerated air dryer



NXC 0500

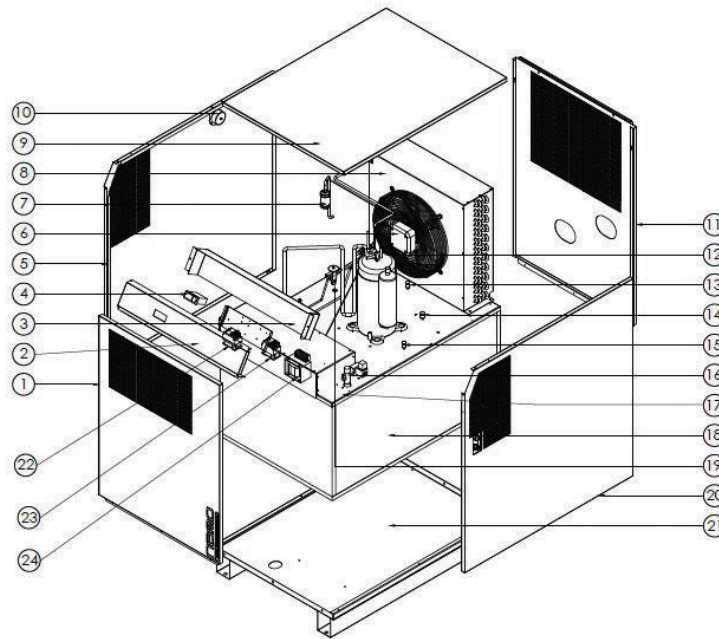

3

| no | description | part no | no | description | part no |
|----|----------------------|---------------|----|----------------------------------|------------------|
| 1 | front panel | NXC0500-1-301 | 14 | low pressure switch | A0802-061N |
| 2 | control panel | NXC0500-1-302 | 15 | fan pressure switch | A0802-054N |
| 3 | control board cover | NXC0500-1-303 | 16 | solenoid valve | A0904-089N |
| 4 | control card | C0104-144N | 17 | middle partition plate | NXC0500-1-901 |
| 5 | side panel left | NXC0500-1-601 | 18 | evaporator unit | SH400-NXC-0500-4 |
| 6 | fan motor | A0702-045N | 19 | expansion valve | A1001-143N |
| 7 | filter | A1001-020N | 20 | side panel right | NXC0500-1-401 |
| 8 | condenser set | SC400-MAST04 | 21 | bottom base assembly | NXC0500-1-100 |
| 9 | top panel | NXC0500-1-701 | 22 | compressor contactor (3P-25A) | C0108-027N |
| 10 | pressure gauge | A1102-040N | 23 | transformer | C0101-31N |
| 11 | back panel assembly | NXC0500-1-500 | | dew point sensor | C0104-143N |
| 12 | compressor | A0101-046N | | y-strainer | A2001-028N |
| 13 | high pressure switch | A0802-053N | | | |



R¹ cycling refrigerated air dryer

NXC 0650 to NXC 0850

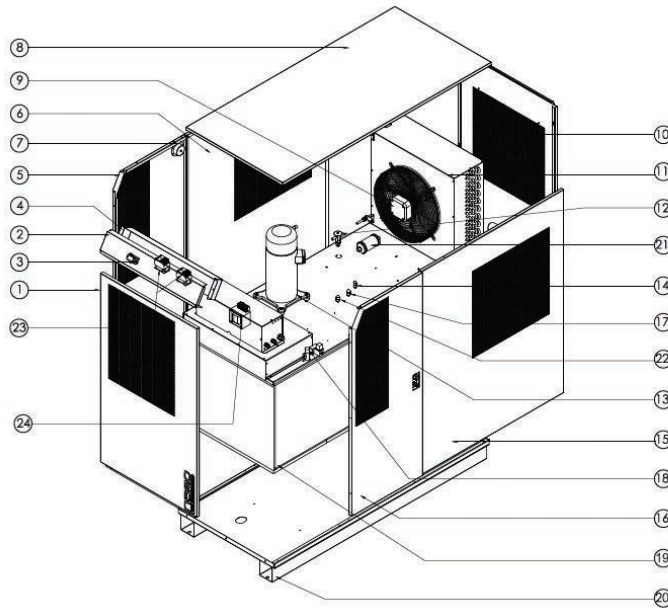

3

| no | description | part no | no | description | part no |
|----|---------------------|---------------|----|----------------------------------|------------------|
| 1 | front panel | NXC0650-1-301 | 16 | right panel - L | NXC0650-1-401 |
| 2 | control panel | NXC0650-1-302 | 17 | high pressure switch | A0802-053N |
| 3 | control card | C0104-144N | 18 | solenoid valve | A0904-089N |
| 4 | control board cover | NXC0650-1-303 | 19 | evaporator unit (NXC 0650) | SH400-NXC-0650-4 |
| 5 | left panel - R | NXC0650-1-602 | | evaporator unit (NXC 0850) | SH400-NXC-0850-4 |
| 6 | left panel - L | NXC0650-1-601 | 20 | bottom base assembly | NXC0650-1-100 |
| 7 | pressure gauge | A1102-040N | 21 | filter | A1001-020N |
| 8 | top panel | NXC0650-1-701 | 22 | fan pressure switch | A0802-054N |
| 9 | fan motor | A0702-045N | 23 | compressor contactor (SP-12) | C0108-215N |
| 10 | back panel | NXC0650-1-500 | | compressor contactor (SP-25A) | C0108-027N |
| 11 | condenser set | SC400-MAST06 | 24 | transformer | C0109-031N |
| 12 | expansion valve | A1001-144N | | dew point sensor | C0104-143N |
| 13 | compressor | A0101-047N | | y-strainer | A2001-028N |
| 14 | low pressure switch | A0802-061N | | middle partition plate | NXC0650-1-901 |
| 15 | right panel - R | NXC0650-1-402 | | | |



R¹ cycling refrigerated air dryer



NXC 1050 to NXC 1300

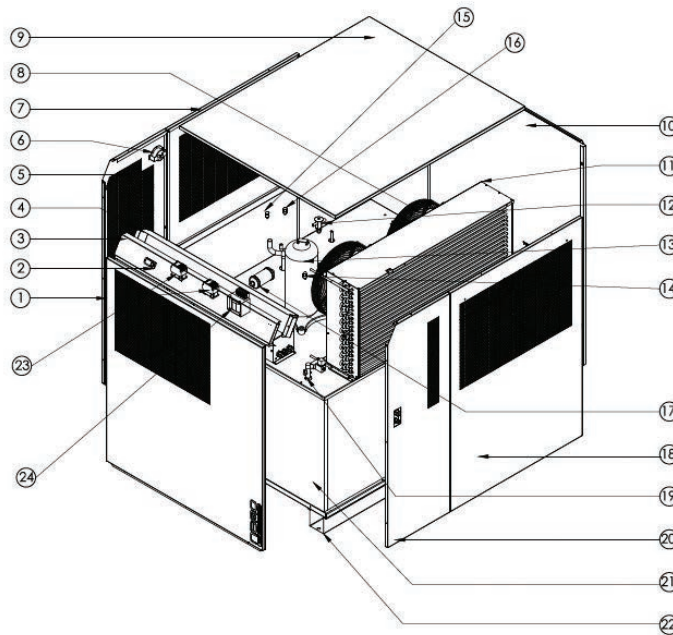

3

| no | description | part no | no | description | part no |
|----|---------------------|---------------|----|----------------------------------|------------------|
| 1 | front panel | NXC1050-1-301 | 15 | high pressure switch | A0802-53N |
| 2 | control card | C0104-144N | 16 | fan pressure switch | A0802-054N |
| 3 | control panel | NXC1050-1-302 | 17 | filter | A1001-016N |
| 4 | control board cover | NXC1050-1-303 | 18 | right panel - R | NXC1050-1-402 |
| 5 | left panel - R | NXC1050-1-602 | 19 | solenoid valve | A0904-089N |
| 6 | pressure gauge | A1102-040N | 20 | right panel - L | NXC1050-1-401 |
| 7 | left panel - L | NXC1050-1-601 | 21 | evaporator unit (NXC 1050) | SH400-NXC-1050-4 |
| 8 | fan motor | A0702-045N | | evaporator unit (NXC 1300) | SH400-NXC-1300-4 |
| 9 | top panel | NXC1050-1-701 | 22 | bottom base assembly | NXC1050-1-100 |
| 10 | back panel | NXC1050-1-500 | 23 | compressor contactor (3P-25A) | C0108-027N |
| 11 | condenser set | SC400-MAST07 | 24 | transformer | C0109-031N |
| 12 | expansion valve | A1001-144N | | dew point sensor | C0104-143N |
| 13 | compressor | A0101-047N | | γ-strainer | A2001-028N |
| 14 | low pressure switch | A0802-061N | | middle partition plate | NXC1050-1-901 |





R¹ cycling refrigerated air dryer

NXC 1600 to NXC 2000

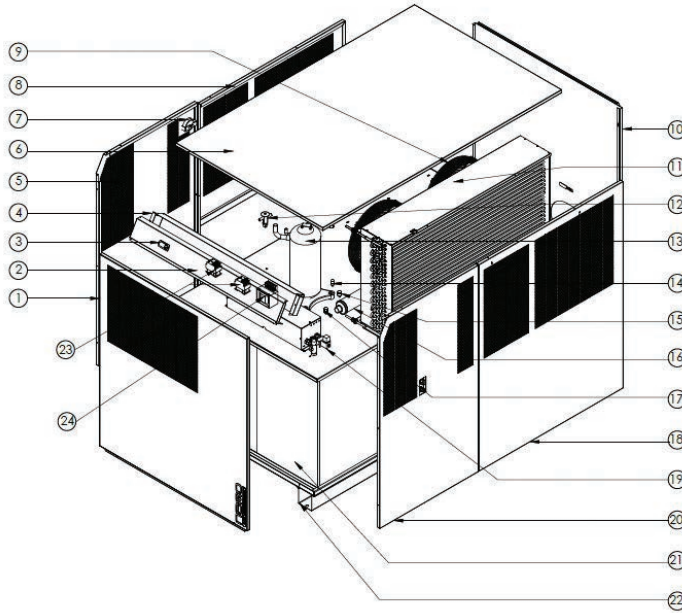

3

| no | description | part no | no | description | part no |
|----|---------------------|---------------|----|-------------------------------|------------------|
| 1 | front panel | NXC1600-1-301 | 15 | high pressure switch | A0802-053N |
| 2 | control panel | NXC1600-1-302 | 16 | filter | A1001-089N |
| 3 | control card | C0104-144N | 17 | fan pressure switch | A0802-054N |
| 4 | control board cover | NXC1600-1-303 | 18 | right panel - R | NXC1600-1-402 |
| 5 | left panel -R | NXC1600-1-602 | 19 | solenoid valve | A0904-089N |
| 6 | top panel | NXC1600-1-701 | 20 | right panel -L | NXC1600-1-401 |
| 7 | pressure gauge | * | 21 | evaporator unit (NXC 1600) | SH400-NXC-1600-4 |
| 8 | left panel - L | NXC1600-1-601 | | evaporator units (NXC 2000) | SH400-NXC-2000-4 |
| 9 | fan motor | A0702-046N | 22 | bottom base assembly | NXC1600-1-100 |
| 10 | back panel | NXC1600-1-500 | 23 | compressor contactor (3P-25A) | C0108-027N |
| 11 | condenser set | SC400-MAST08 | 24 | transformer | C0109-031N |
| 12 | expansion valve | A1001-144N | | dew point sensor | C0104-143N |
| 13 | compressor | A0101-049N | | overload | C0108-235N |
| 14 | low pressure switch | A0802-061N | | middle partition plate | NXC1600-1-901 |

R¹

cycling refrigerated air dryer



3.3 electrical wirings

NXC 0020 - 115V/1/60

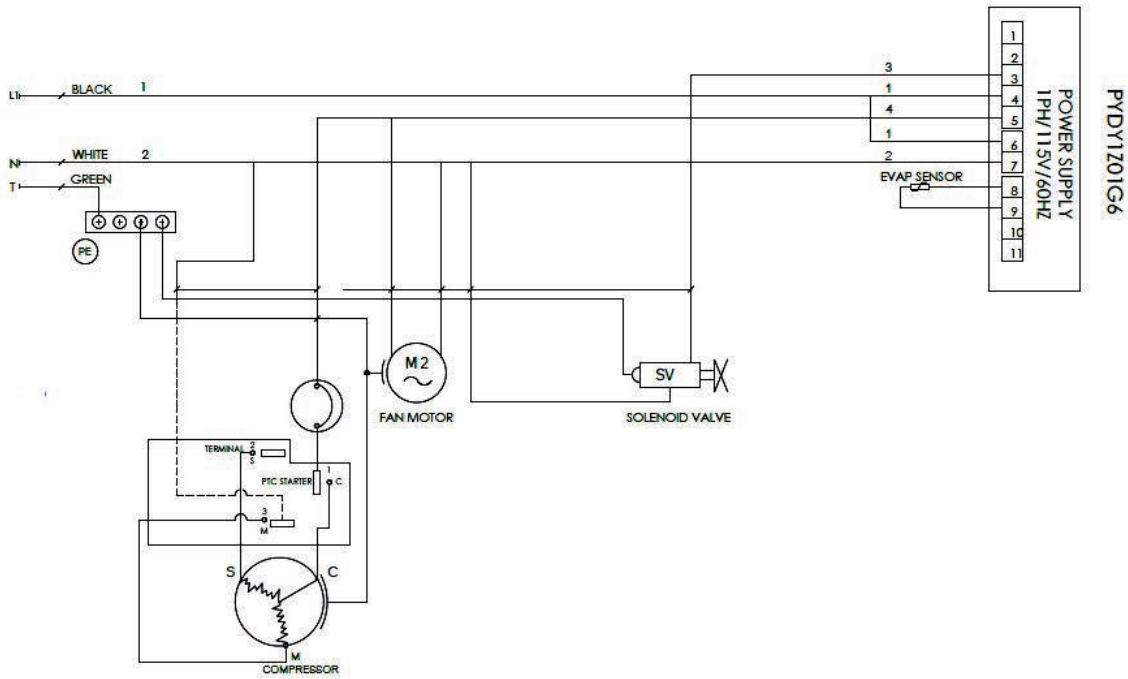

NXC 0030 to NXC 0045 - 115V/1/60Hz

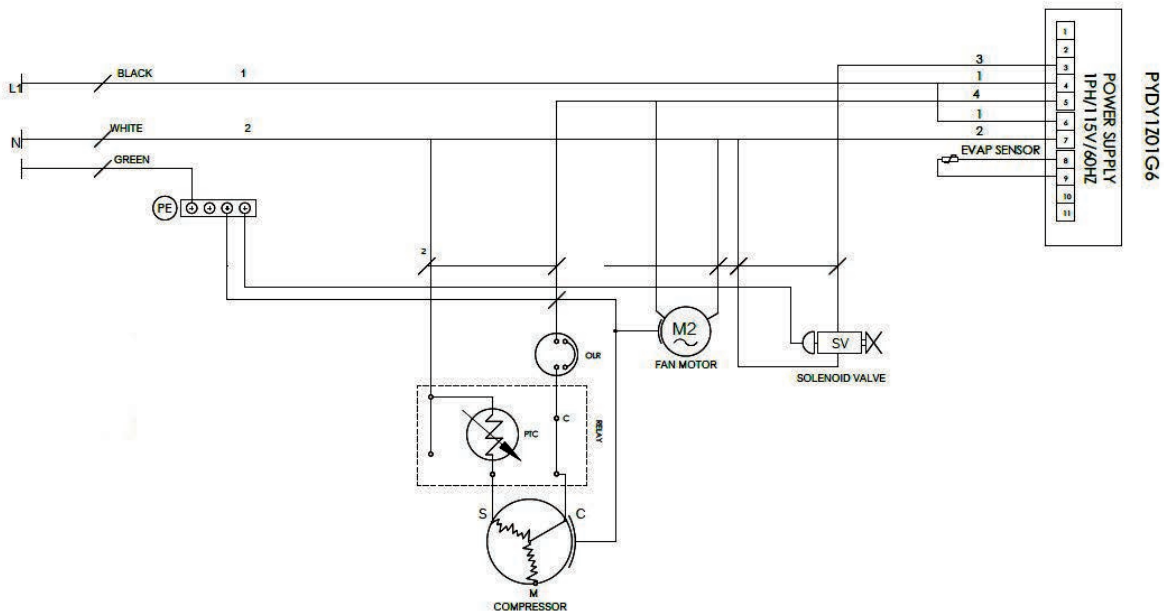



R¹ cycling refrigerated air dryer

NXC 0065 to NXC 0110 - 115V/1/60

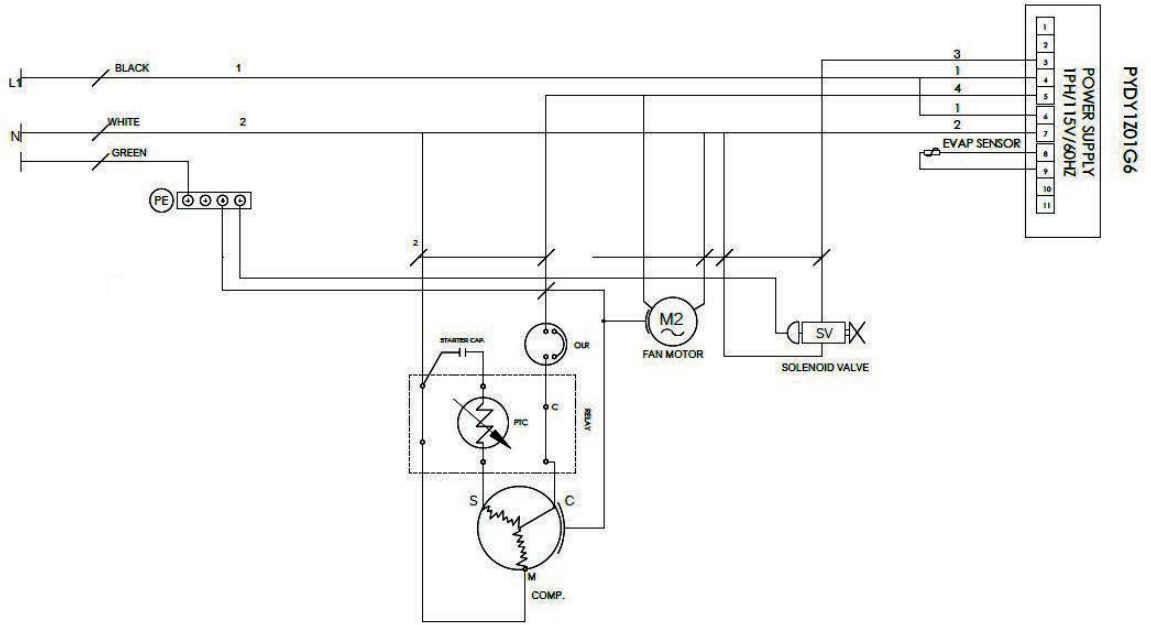

3

NXC 0130 to NXC 0165 - 115V/1/60Hz

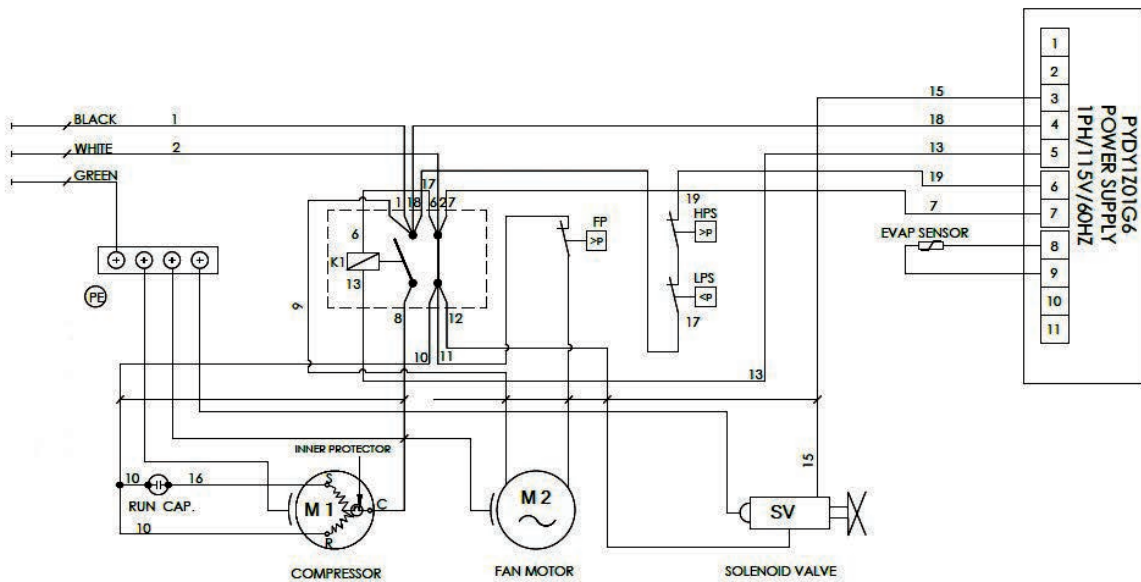

R¹

cycling refrigerated air dryer



NXC 0200 to NXC 0400 - 230V/1/60

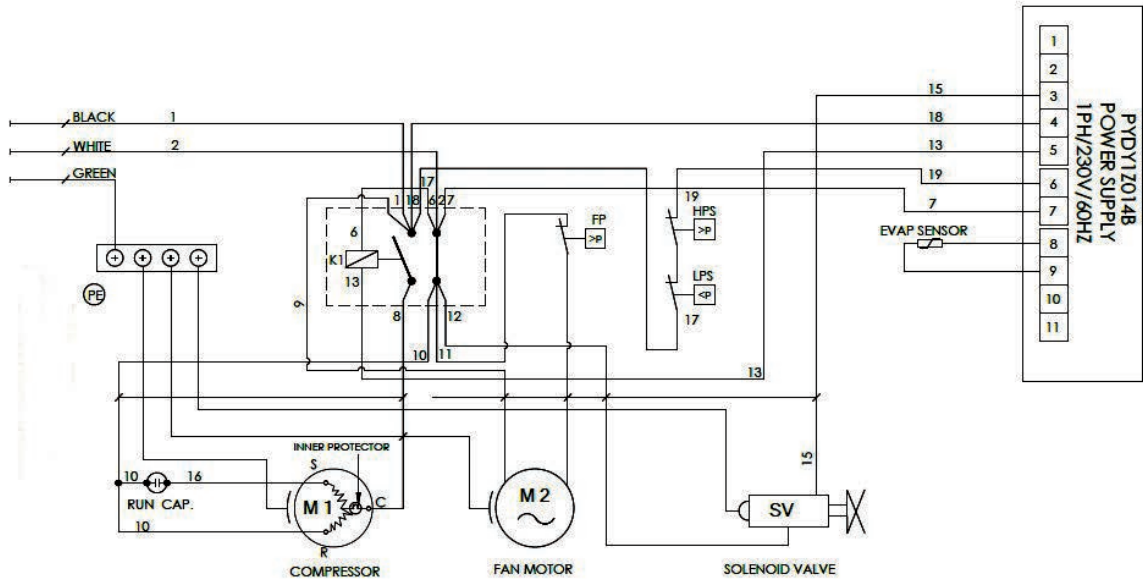

3

NXC 0200 to NXC 0400 - 460V/3/60Hz

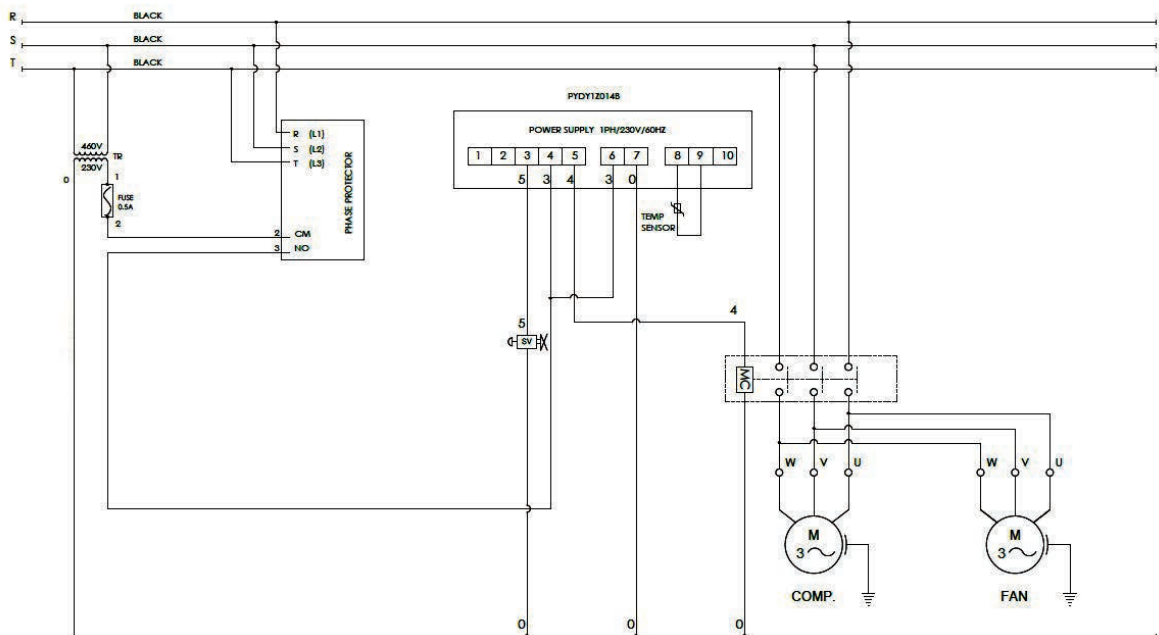



R¹ cycling refrigerated air dryer

NXC 0500 to NXC 0850 - 460V/3/60Hz

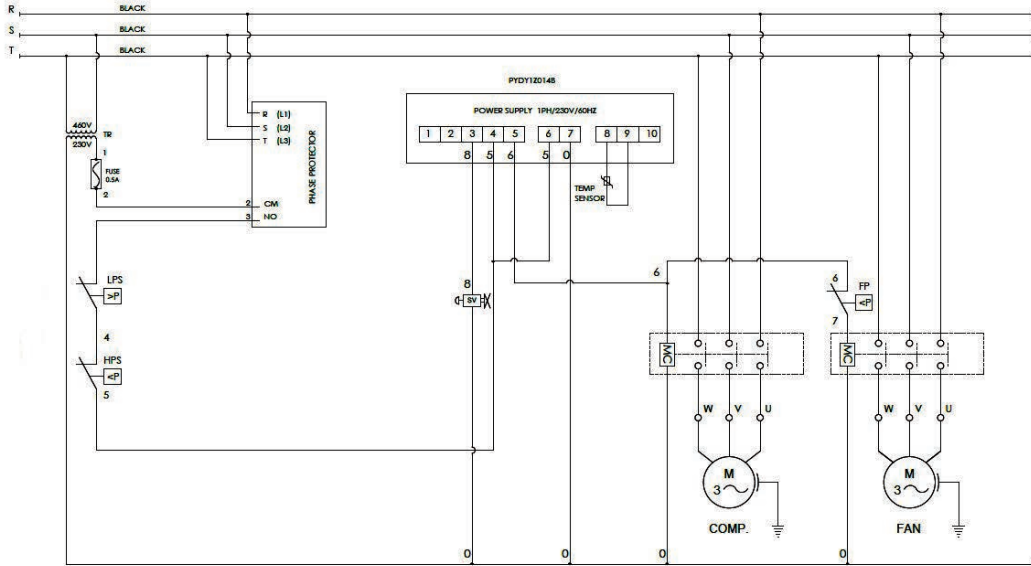

3

NXC 1050 to NXC 2000 - 460V/3/60Hz

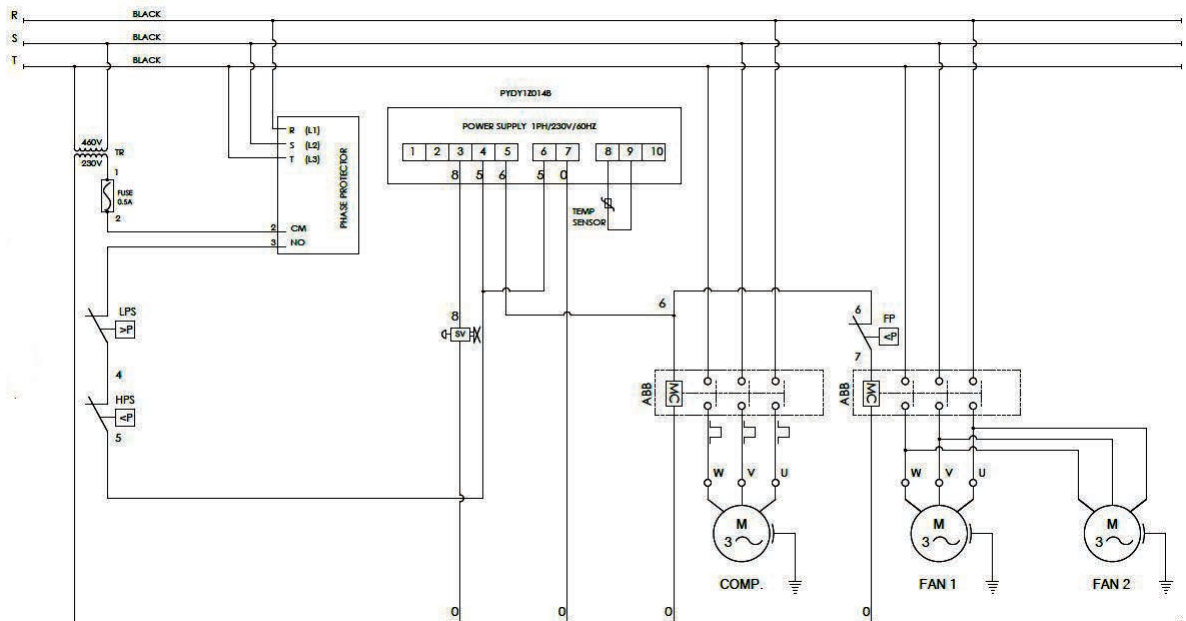

R¹

cycling refrigerated air dryer



3.4 appendixes

| reference | power supply | max power installed | full load amps | air connections/pressure | | refrigerant gas | weight |
|-----------|--------------|---------------------|----------------|--------------------------|----------------------------|-----------------|--------|
| model | 60 Hz only | (kW) | (A) | NPT (inch) | max working pressure (psi) | HFC | lbs |
| NXC 0020 | 1/115V/60Hz | 0.30 | 3.80 | ½" | 232 | R134a | 82 |
| NXC 0030 | 1/115V/60Hz | 0.31 | 3.85 | ¾" | 232 | R134a | 106 |
| NXC 0045 | 1/115V/60Hz | 0.33 | 4.00 | ¾" | 232 | R134a | 112 |
| NXC 0065 | 1/115V/60Hz | 0.61 | 7.86 | 1" | 232 | R134a | 196 |
| NXC 0090 | 1/115V/60Hz | 0.64 | 8.18 | 1" | 232 | R134a | 201 |
| NXC 0110 | 1/115V/60Hz | 0.66 | 8.53 | 1" | 232 | R134a | 205 |
| NXC 0130 | 1/115V/60Hz | 1.26 | 11.30 | 1½" | 232 | R407c | 291 |
| NXC 0165 | 1/115V/60Hz | 1.33 | 11.90 | 1½" | 232 | R407c | 302 |
| NXC 0200 | 1/230V/60Hz | 2.12 | 10.70 | 2" | 232 | R407c | 386 |
| NXC 0200 | 3/460V/60Hz | 1.83 | 4.63 | 2" | 232 | R134a | 386 |
| NXC 0265 | 1/230V/60Hz | 2.12 | 10.70 | 2" | 232 | R407c | 386 |
| NXC 0265 | 3/460V/60Hz | 1.83 | 4.63 | 2" | 232 | R134a | 386 |
| NXC 0325 | 1/230V/60Hz | 2.20 | 11.20 | 2" | 232 | R407c | 386 |
| NXC 0325 | 3/460V/60Hz | 1.91 | 4.82 | 2" | 232 | R134a | 397 |
| NXC 0400 | 1/230V/60Hz | 2.29 | 11.60 | 2" | 232 | R407c | 408 |
| NXC 0400 | 3/460V/60Hz | 1.98 | 5.01 | 2" | 232 | R134a | 408 |
| NXC 0500 | 3/460V/60Hz | 3.25 | 6.10 | 2½" | 232 | R407c | 539 |
| NXC 0650 | 3/460V/60Hz | 4.50 | 7.92 | 3" | 232 | R407c | 961 |
| NXC 0850 | 3/460V/60Hz | 4.68 | 8.24 | 3" | 232 | R407c | 992 |
| NXC 1050 | 3/460V/60Hz | 6.50 | 12.20 | 3" | 232 | R407c | 1159 |
| NXC 1300 | 3/460V/60Hz | 6.70 | 12.60 | 3" | 232 | R407c | 1195 |
| NXC 1600 | 3/460V/60Hz | 9.00 | 15.80 | 4" Flg | 232 | R407c | 1586 |
| NXC 2000 | 3/460V/60Hz | 9.40 | 16.40 | 4" Flg | 232 | R407c | 1635 |

3





R¹

cycling refrigerated air dryer

4.1 R407c gas chemical safety data sheet

PRODUCT NAME: REFRIGERANT GAS R407c

COMPOSITION/INFORMATION ON INGREDIENTS

EEC No.: 200-839-4 HFC32, 206-557-8 HFC125, 212-377-0 HFC134a

| HAZARDOUS INGREDIENT(S) | CAS No. | % (w/w) | Symbol | R Phrases |
|--------------------------------------|-------------|---------|--------|-----------|
| Difluoromethane (HFC 32) | 000075-10-5 | 23 | F+ | R12 |
| Pentafluoroethane (HFC 125) | 000354-33-6 | 25 | | |
| 1,1,1,2-tetrafluoroethane (HFC 134a) | 000811-97-2 | 52 | | |

HAZARDS IDENTIFICATION

Low acute toxicity. High exposures may cause an abnormal heart rhythm and prove suddenly fatal. Very high atmospheric concentrations may cause anaesthetic effects and asphyxiation. Liquid splashes or spray may cause freeze burns to skin and eyes.

FIRST-AID MEASURES

The first aid advice given for skin contact, eye contact, and ingestion is applicable following exposures to the liquid or spray. See also TOXICOLOGICAL INFORMATION.

- Inhalation: Remove patient from exposure, keep warm and at rest. Administer oxygen if necessary. Apply artificial respiration if breathing has ceased or shows signs of failing. In the event of cardiac arrest apply external cardiac massage. Obtain immediate medical attention.
- Skin Contact: Thaw affected areas with water. Remove contaminated clothing. Caution: clothing may adhere to the skin in the case of freeze burns. After contact with skin, wash immediately with plenty of warm water. If irritation or blistering occur obtain medical attention.
- Eye Contact: Immediately irrigate with eyewash solution or clean water, holding the eyelids apart, for at least 10 minutes. Obtain immediate medical attention.
- Ingestion: Unlikely route of exposure. Do not induce vomiting. Provided the patient is conscious, wash out mouth with water and give 200-300 ml (half a pint) of water to drink. Obtain immediate medical attention.

Further Medical Treatment

Symptomatic treatment and supportive therapy as indicated.

Adrenaline and similar sympathomimetic drugs should be avoided following exposure as cardiac arrhythmia may result with possible subsequent cardiac arrest.

R¹

cycling refrigerated air dryer



FIRE-FIGHTING MEASURES

This refrigerant is not flammable in air under ambient conditions of temperature and pressure. Certain mixtures of this refrigerant and air when under pressure may be flammable. Mixtures of this refrigerant and air under pressure should be avoided.

Certain mixtures of HFCs and chlorine may be flammable or reactive under certain conditions.

Thermal decomposition will evolve very toxic and corrosive vapors. (hydrogen fluoride)

Containers may burst if overheated.

Extinguishing Media: As appropriate for surrounding fire. Water spray should be used to cool containers.

Fire Fighting Protective Equipment: A self contained breathing apparatus and full protective clothing must be worn in fire conditions. See Also EXPOSURE CONTROLS/ PERSONAL PROTECTION.

ACCIDENTAL RELEASE MEASURES

Ensure suitable personal protection (including respiratory protection) during removal of spillages. See Also **EXPOSURE CONTROLS/PERSONAL PROTECTION**.

Provided it is safe to do so, isolate the source of the leak. Allow small spillages to evaporate provided there is adequate ventilation.

Large spillages: Ventilate area. Contain spillages with sand, earth or any suitable adsorbent material. Prevent liquid from entering drains, sewers, basements and workpits since the vapor may create a suffocating atmosphere.

HANDLING AND STORAGE

HANDLING

Avoid inhalation of high concentrations of vapors. Atmospheric levels should be controlled in compliance with the occupational exposure limit. Atmospheric concentrations well below the occupational exposure limit can be achieved by good occupational hygiene practice.

The vapor is heavier than air, high concentrations may be produced at low levels where general ventilation is poor, in such cases provide adequate ventilation or wear suitable respiratory protective equipment with positive air supply.

Avoid contact with naked flames and hot surfaces as corrosive and very toxic decomposition products can be formed.

Avoid contact between the liquid and skin and eyes.

For correct refrigerant composition, systems should be charged using the liquid phase and not the vapor phase.

Process Hazards

Liquid refrigerant transfers between refrigerant containers and to and from systems can result in static generation. Ensure adequate earthing. Certain mixtures of HFCs and chlorine may be flammable or reactive under certain conditions.

Keep container dry.

Storage temperature (Deg C): < 45

4





R¹ cycling refrigerated air dryer

STORAGE

Keep in a well ventilated place. Keep in a cool place away from fire risk, direct sunlight and all sources of heat such as electric and steam radiators.

Avoid storing near to the intake of air conditioning units, boiler units and open drains.

Cylinders and Drums:

Keep container dry.

Storage temperature (Deg C): < 45

EXPOSURE CONTROLS/PERSONAL PROTECTION

Wear suitable protective clothing, gloves and eye/face protection. Wear thermal insulating gloves when handling liquefied gases.

In cases of insufficient ventilation, where exposure to high concentrations of vapor is possible, suitable respiratory protective equipment with positive air supply should be used.

4

Occupational Exposure Limits

| HAZARDOUS INGREDIENT(S) | TWA ppm | TWA mg/m ³ | STEL ppm | STEL mg/m ³ | |
|--|------------|--------------------------|-------------|---------------------------|-----|
| Difluoromethane (HFC 32) | 1000 | - | - | - | COM |
| Pentafluoroethane (HFC 125) | 1000 | - | - | - | COM |
| 1,1,1,2- Tetrafluoroethane (HFC 134a) | 1000 | 4240 | - | - | OES |

PHYSICAL AND CHEMICAL PROPERTIES

| | |
|---------------------------------|--|
| Form: | liquified gas |
| Color: | colorless |
| Odor: | slight ethereal |
| Boiling Point (Deg C): | -44.3 to -37.1 (boiling range) |
| Vapor Pressure (mm Hg): | 7810 at 20 Deg C |
| Density (g/ml): | 1.16 at 20 Deg C |
| Solubility (Water): | insoluble |
| Solubility (Other): soluble in: | chlorinated solvents, alcohols, esters |
| Vapor Density (Air= 1): | 3.0 at bubble point temperature |

STABILITY AND REACTIVITY

| | |
|-------------------------------------|---|
| Hazardous Reactions: | Certain mixtures of HFCs and chlorine may be flammable or reactive under certain conditions. |
| Incompatible materials: | finely divided metals, magnesium and alloys containing more than 2% magnesium. Can react violently if in contact with alkali metals and alkaline earth metals -sodium, potassium, barium. |
| Hazardous Decomposition Product(s): | hydrogen fluoride by thermal decomposition and hydrolysis. |

TOXICOLOGICAL INFORMATION

Inhalation

High exposures may cause an abnormal heart rhythm and prove suddenly fatal. Very high atmospheric concentrations may cause anaesthetic effects and asphyxiation.

R¹

cycling refrigerated air dryer



Skin Contact

Liquid splashes or spray may cause freeze burns. Unlikely to be hazardous by skin absorption

Eye Contact

Liquid splashes or spray may cause freeze burns.

Ingestion

Highly unlikely - but should this occur freeze burns will result.

Long Term Exposure

HFC 32: An inhalation study in animals has shown that repeated exposures produce no significant effects (49,500ppm in rats).

HFC 125: An inhalation study in animals has shown that repeated exposures produce no significant effects (50,000ppm in rats).

HFC 134a: A lifetime inhalation study in rats has shown that exposure to 50,000ppm resulted in benign tumors of the testis. The increased tumor incidence was observed only after prolonged exposure to high levels, and is considered not to be of relevance to humans occupationally exposed to HFC 134a at or below the occupational exposure limit.

ECOLOGICAL INFORMATION

Environmental Fate and Distribution

High tonnage material produced in wholly contained systems. High tonnage material used in open systems. Vapor.

Persistence and Degradation

HFC 32: Decomposed comparatively rapidly in the lower atmosphere (troposphere). Atmospheric lifetime is 5.6 year(s). Has a Halocarbon Global Warming Potential (HGWP) of 0.15 (relative to a value of 1 for CFC 11) or a Global Warming Potential (GWP) of 650 (relative to a value of 1 for carbon dioxide at 100 years).

HFC 125: Decomposed slowly in the lower atmosphere (troposphere). Atmospheric lifetime is 32.6 year(s). Has a Halocarbon Global Warming Potential (HGWP) of 0.70 (relative to a value of 1 for CFC 11) or a Global Warming Potential (GWP) of 2800 (relative to a value of 1 for carbon dioxide at 100 years).

HFC 134a: Decomposed comparatively rapidly in the lower atmosphere (troposphere). Atmospheric lifetime is 13.6 year(s). Has a Halocarbon Global Warming Potential (HGWP) of 0.30 (relative to a value of 1 for CFC 11) or a Global Warming Potential (GWP) of 1300 (relative to a value of 1 for carbon dioxide at 100 years).

HFC 32, HFC 125, HFC 134a: Do not influence photochemical smog (i.e. they are not VOCs under the terms of the UNECE agreement). Do not deplete ozone.

4





R¹

cycling refrigerated air dryer

Effect on Effluent Treatment

Discharges of the product will enter the atmosphere and will not result in long term aqueous contamination.

DISPOSAL CONSIDERATIONS

Best to recover and recycle. If this is not possible, destruction is to be in an approved facility which is equipped to absorb and neutralise acid gases and other toxic processing products.

TRANSPORT INFORMATION

UN No.: 3340

AIR

ICAO/IATA

-primary: 2.2

SEA

IMDG

-primary: 2.2

Marine Pollutant: Not classified as a Marine Pollutant

Proper Shipping Name: REFRIGERANT GAS R 407C

ROAD/RAIL

ADR/RID Class: 2

ADR/RID Item No: 2A

ADR Sin: 3340

REGULATORY INFORMATION

Not Classified as Hazardous to Users.

GLOSSARY

OES: Occupational Exposure Standard (UK HSE EH40)

MEL: Maximum Exposure Limit (UK HSE EH40)

COM: The company aims to control exposure in its workplace to this limit

TLV: The company aims to control exposure in its workplace to the ACGIH limit

TLV-C: The company aims to control exposure in its workplace to the ACGIH Ceiling limit

MAK: The company aims to control exposure in its workplace to the German limit

Sk: Can be absorbed through skin

Sen: Capable of causing respiratory sensitization

Bmgv: Biological monitoring guidance value (UK HSE EH40)

ILV: Indicative Limit Value (UK HSE EH40)

4



R¹

cycling refrigerated air dryer



4.2 R134a gas chemical safety data sheet

PRODUCT NAME: REFRIGERANT GAS R134a

COMPOSITION/INFORMATION ON INGREDIENTS

CAS No.: 000811-97-2

EEC No.: 212-377-0

| HAZARDOUS INGREDIENT(S) | CAS No. | Symbol | R Phrases |
|--------------------------------------|-------------|--------|-----------|
| 1,1,1,2-tetrafluoroethane (HFC 134a) | 000811-97-2 | | |

HAZARDS IDENTIFICATION

Low acute toxicity. High exposures may cause an abnormal heart rhythm and prove suddenly fatal. Very high atmospheric concentrations may cause anaesthetic effects and asphyxiation. Liquid splashes or spray may cause freeze burns to skin and eyes.

FIRST-AID MEASURES

The first aid advice given for skin contact, eye contact, and ingestion is applicable following exposures to the liquid or spray. See also TOXICOLOGICAL INFORMATION.

Inhalation: Remove patient from exposure, keep warm and at rest. Administer oxygen if necessary. Apply artificial respiration if breathing has ceased or shows signs of failing. In the event of cardiac arrest apply external cardiac massage. Obtain immediate medical attention.

Skin Contact: Thaw affected areas with water. Remove contaminated clothing. Caution: clothing may adhere to the skin in the case of freeze burns. After contact with skin, wash immediately with plenty of warm water. If irritation or blistering occur obtain medical attention.

Eye Contact: Immediately irrigate with eyewash solution or clean water, holding the eyelids apart, for at least 10 minutes. Obtain immediate medical attention.

Ingestion: Unlikely route of exposure.

Do not induce vomiting. Provided the patient is conscious, wash out mouth with water and give 200-300 ml (half a pint) of water to drink. Obtain immediate medical attention.

Further Medical Treatment

Symptomatic treatment and supportive therapy as indicated.

Adrenaline and similar sympathomimetic drugs should be avoided following exposure as cardiac arrhythmia may result with possible subsequent cardiac arrest.

FIRE-FIGHTING MEASURES

This refrigerant is not flammable in air under ambient conditions of temperature and pressure. Certain mixtures of this refrigerant and air when under pressure may be flammable. Mixtures of this refrigerant and air under pressure should be avoided.

Certain mixtures of HFCs and chlorine may be flammable or reactive under certain conditions. Thermal decomposition will evolve very toxic and corrosive vapors. (hydrogen fluoride)

Contains may burst if overheated.

4





R¹

cycling refrigerated air dryer

Extinguishing Media:

As appropriate for surrounding fire. Water spray should be used to cool containers.

Fire Fighting Protective Equipment:

A self-contained breathing apparatus and full protective clothing must be worn in fire conditions. See Also EXPOSURE CONTROLS/PERSONAL PROTECTION.

ACCIDENTAL RELEASE MEASURES

Ensure suitable personal protection (including respiratory protection) during removal of spillages. See Also EXPOSURE CONTROLS/PERSONAL PROTECTION.

Provided it is safe to do so, isolate the source of the leak. Allow small spillages to evaporate provided there is adequate ventilation.

Large spillages: Ventilate area. Contain spillages with sand, earth or any suitable adsorbent material. Prevent liquid from entering drains, sewers, basements and workpits since the vapor may create a suffocating atmosphere.

HANDLING AND STORAGE**HANDLING**

Avoid inhalation of high concentrations of vapors. Atmospheric levels should be controlled in compliance with the occupational exposure limit. Atmospheric concentrations well below the occupational exposure limit can be achieved by good occupational hygiene practice.

The vapor is heavier than air, high concentrations may be produced at low levels where general ventilation is poor, in such cases provide adequate ventilation or wear suitable respiratory protective equipment with positive air supply.

Avoid contact with naked flames and hot surfaces as corrosive and very toxic decomposition products can be formed.

Avoid contact between the liquid and skin and eyes.

For correct refrigerant composition, systems should be charged using the liquid phase and not the vapor phase.

STORAGE

Keep in a well ventilated place. Keep in a cool place away from fire risk, direct sunlight and all sources of heat such as electric and steam radiators.

Avoid storing near to the intake of air conditioning units, boiler units and open drains.

Cylinders and Drums:

Keep container dry.

Storage temperature (Deg C): < 45

EXPOSURE CONTROLS/PERSONAL PROTECTION

Wear suitable protective clothing, gloves and eye/face protection. Wear thermal insulating gloves when handling liquefied gases.

In cases of insufficient ventilation, where exposure to high concentrations of vapor is possible, suitable respiratory protective equipment with positive air supply should be used.

4



R¹

cycling refrigerated air dryer

**Occupational Exposure Limits**

| HAZARDOUS INGREDIENT(S) | TWA ppm | TWA mg/m ³ | STEL ppm | STEL mg/m ³ | |
|--|------------|--------------------------|-------------|---------------------------|-----|
| 1,1,1,2- Tetrafluoroethane (HFC 134a) | 1000 | 4240 | - | - | OES |

PHYSICAL AND CHEMICAL PROPERTIES

| | |
|---------------------------------|--|
| Form: | liquified gas |
| Color: | colorless |
| Odor: | slight ethereal |
| Boiling Point (Deg C): | -26.2 |
| Vapor Pressure (mm Hg): | 4270 at 20 Deg C |
| Density (g/ml): | 1.22 at 20 Deg C |
| Solubility (Water): | insoluble |
| Solubility (Other): soluble in: | chlorinated solvents, alcohols, esters |
| Vapor Density (Air= 1): | 3.66 at bubble point temperature |

STABILITY AND REACTIVITY

Hazardous Reactions: Certain mixtures of HFCs and chlorine may be flammable or reactive under certain conditions.

Incompatible materials: finely divided metals, magnesium and alloys containing more than 2% magnesium. Can react violently if in contact with alkali metals and alkaline earth metals -sodium, potassium, barium.

Hazardous Decomposition Product(s): hydrogen fluoride by thermal decomposition and hydrolysis.

TOXICOLOGICAL INFORMATION**Inhalation**

High exposures may cause an abnormal heart rhythm and prove suddenly fatal. Very high atmospheric concentrations may cause anaesthetic effects and asphyxiation.

Skin Contact

Liquid splashes or spray may cause freeze burns. Unlikely to be hazardous by skin absorption.

Eye Contact

Liquid splashes or spray may cause freeze burns.

Ingestion

Highly unlikely - but should this occur freeze burns will result.

Long Term Exposure

A lifetime inhalation study in rats has shown that exposure to 50,000ppm resulted in benign tumors of the testis. The increased tumor incidence was observed only after prolonged exposure to high levels, and is considered not to be of relevance to humans occupationally exposed to HFC 134a at or below the occupational exposure limit.

4





R¹

cycling refrigerated air dryer

ECOLOGICAL INFORMATION

Environmental Fate and Distribution

High tonnage material produced in wholly contained systems. High tonnage material used in open systems.

Vapor.Persistence and Degradation

Decomposed comparatively rapidly in the lower atmosphere (troposphere). Atmospheric lifetime is 13.6 year(s). Has a Halocarbon Global Warming Potential (HGWP) of 0.30 (relative to a value of 1 for CFC 11) or a Global Warming Potential (GWP) of 1300 (relative to a value of 1 for carbon dioxide at 100 years).

Effect on Effluent Treatment

Discharges of the product will enter the atmosphere and will not result in long term aqueous contamination.

DISPOSAL CONSIDERATIONS

Best to recover and recycle. If this is not possible, destruction is to be in an approved facility which is equipped to absorb and neutralise acid gases and other toxic processing products.

TRANSPORT INFORMATION

UN No.: 3159

AIR

ICAO/IATA

-primary: 2.2

SEA

IMDG

-primary: 2.2

Marine Pollutant: Not classified as a Marine Pollutant

Proper Shipping Name: 1,1,1,2-TETRAFLUOROETHANE

ROAD/RAIL

ADR/RID Class: 2

ADR/RID Item No: 2A

ADR Sin: 3159

REGULATORY INFORMATION

Not Classified as Hazardous to Users.

GLOSSARY

OES: Occupational Exposure Standard (UK HSE EH40)

MEL: Maximum Exposure Limit (UK HSE EH40)

COM: The company aims to control exposure in its workplace to this limit

TLV: The company aims to control exposure in its workplace to the ACGIH limit

TLV-C: The company aims to control exposure in its workplace to the ACGIH Ceiling limit

MAK: The company aims to control exposure in its workplace to the German limit

Sk: Can be absorbed through skin

Sen: Capable of causing respiratory sensitization

Bmgv: Biological monitoring guidance value (UK HSE EH40)

ILV: Indicative Limit Value (UK HSE EH40)

4



additional nano products



F-series industrial filters

D-series desiccant dryers



B-series breathing air purifiers

GEN₂-series nitrogen generators



R-series refrigerated dryers

V-series oil vapor removal systems



S-series oil water separators



nano



nano-purification solutions llc

5509 david cox road
charlotte,nc 28269
usa

tel: 704.897.2182
fax: 704.897.2183
www.n-psi.com
support@n-psi.com



nano-purification solutions ltd

dukesway,
team valley trading estate,
gateshead,
ne11 opz
united kingdom

tel: +44 (0) 191 497 7700
www.n-psi.co.uk
enquiries@n-psi.co.uk



nano-purification solutions

188 bunting road, unit 8B
st catharines, ontario
l2m 3y1
canada

tel: 905.684.6266
fax: 704.897.2183
www.n-psi.com
support@n-psi.com