

INSTALLATION, OPERATION & MAINTENANCE MANUAL FOR

HEATLESS REGENERATIVE COMPRESSED AIR DRYER

models

HL-200 through HL-2000

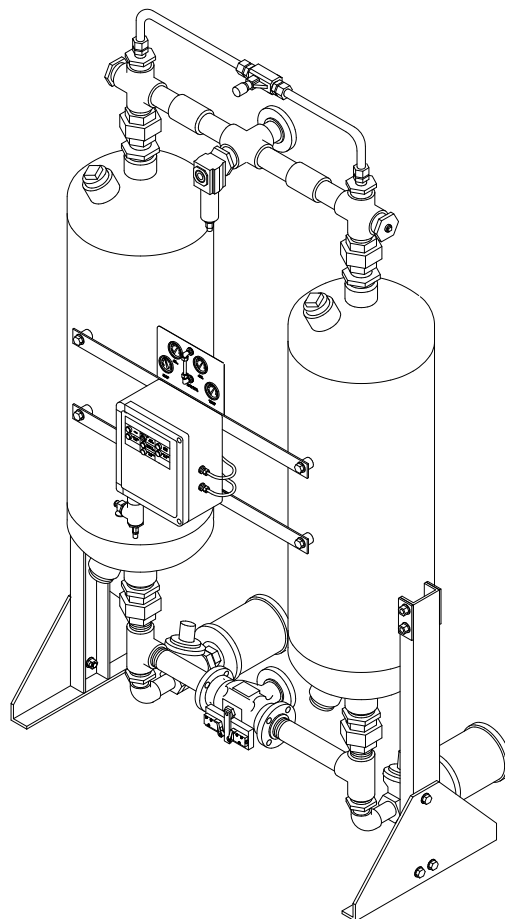

WARNING

READ ALL INFORMATION IN THIS MANUAL BEFORE BEGINNING INSTALLATION OR OPERATION OF THE DRYER. BEFORE STARTING INSTALLATION AND/OR MAINTENANCE PROCEDURES, TURN OFF THE MAIN POWER TO THE DRYER AND COMPLETELY DEPRESSURIZE THE UNIT TO PREVENT PERSONAL INJURY.

DO NOT REMOVE, REPAIR, OR REPLACE ANY ITEM ON THIS DRYER WHILE IT IS UNDER PRESSURE.

NEVER OPERATE THIS DRYER ABOVE THE RATED OPERATING CONDITIONS. OPERATION ABOVE SPECIFIED CONDITIONS WILL RESULT IN DECREASED PERFORMANCE, POSSIBLE DAMAGE TO THE UNIT AND/OR PERSONAL INJURY.

SEE BACK OF THIS MANUAL FOR ADDITIONAL SAFETY INSTRUCTIONS.

1.1 HANDLING INSTRUCTIONS**WARNING**

DO NOT LIFT THE DRYER BY PIPING OR CONTROL BOX. THESE COMPONENTS ARE NOT DESIGNED TO HOLD THE WEIGHT OF THE DRYER. PERSONAL INJURY AND/OR EQUIPMENT DAMAGE MAY RESULT.

Lift the dryer by the lifting lugs on both vessels.

If the unit is to be lifted by an overhead device, attach the lifting chains or cables to the skid angle and the vessel lifting lugs. Make sure that the chains or cables are clear of all piping and dryer components.

1.2 STORAGE INSTRUCTIONS

The ideal place to store the unit is indoors. The location should be free from corrosive gasses and extreme humidity. These conditions will cause damage to the unit. The unit should be covered with a tarpaulin to keep the unit clean.

If the unit is to be stored outdoors, it MUST BE covered completely. The cover must be adequate enough to prevent rain or snow from accumulating on the dryer. The location must be free of standing water and mud. The preferred location, if outdoors, is on a paved surface.

1.3 EQUIPMENT CHECK

Inspect the dryer for any damage that may have occurred during shipment. Inspect all fittings, piping connections, fasteners, etc. for loose connections. Also check gauges and lights for cracks or breakage.

IF DRYER HAS BEEN DAMAGED DURING SHIPMENT:

- (1) NOTIFY CARRIER IMMEDIATELY AND FILE A CLAIM.
- (2) CONSULT FACTORY BEFORE OPERATING THE DRYER.

SAFETY INSTRUCTIONS**SECTION 2****2.1 HANDLING**

DO NOT LIFT THE DRYER BY PIPING OR CONTROL BOX. THESE COMPONENTS ARE NOT DESIGNED TO HOLD THE WEIGHT OF THE DRYER. PERSONAL INJURY AND/OR EQUIPMENT DAMAGE MAY RESULT.

WHEN LIFTING THE DRYER, ALWAYS USE THE LIFTING LUGS PROVIDED ON BOTH TOWERS.

MAKE SURE THAT ALL EQUIPMENT BEING USED TO LIFT THE DRYER IS CAPABLE OF LIFTING THE WEIGHT OF THE DRYER.

IF THE DRYER IS TO BE TRANSPORTED OVERHEAD, MAKE SURE THAT ALL PERSONNEL ARE ALERTED AND SAFETY PROCEDURES ARE FOLLOWED.

2.2 INSTALLATION

BEFORE STARTING INSTALLATION AND/OR MAINTENANCE PROCEDURES, TURN OFF POWER AND DEPRESSURIZE UNIT TO PREVENT INJURY. SERIOUS PERSONAL INJURY MAY RESULT IF THESE SAFETY RULES ARE NOT FOLLOWED.

DO NOT REMOVE, REPAIR, OR REPLACE ANY ITEM ON DRYER WHILE IT IS UNDER PRESSURE. TURN OFF MAIN POWER TO THE DRYER AND DEPRESSURIZE THE DRYER COMPLETELY BEFORE STARTING INSTALLATION AND/OR MAINTENANCE PROCEDURES.

THESE ASME CODE VESSELS MUST BE PROTECTED BY PRESURE RELIEF VALVES. Refer to OSHA 1910.169 Par. b, Sub. Par (3) and ASME Boiler and Pressure Vessel Code, Section VIII, Division 1, UG-125 through UG-136. Also check government regulations, i.e., state and local codes.

WHEN INSTALLING AND OPERATING THIS EQUIPMENT, COMPLY WITH THE NATIONAL ELECTRICAL CODE AND ANY APPLICABLE FEDERAL, STATE, AND LOCAL CODES.

WHEN INSTALLING THIS DRYER, MAKE SURE THAT THE NEMA RATING OF THE CONTROL BOX IS APPLICABLE TO THE INSTALLATION.

MAKE SURE THAT ALL CUSTOMER SUPPLIED WIRING AND ELECTRICAL DEVICES ARE PROPERLY SIZED TO HANDLE THE ELECTRICAL REQUIREMENTS OF THE DRYER.

ALWAYS WEAR EYE PROTECTION, GLOVES AND A RESPIRATORY PROTECTIVE DEVICE WHEN HANDLING THE DESICCANT. THE DUST FROM THE DESICCANT MAY CAUSE EYE AND SKIN IRRITATION. AVOID BREATHING THE DUST AND PROLONGED CONTACT WITH THE SKIN.

FIRST AID IN CASE OF EYE CONTACT WITH DESICCANT DUST; IMMEDIATELY FLUSH THE EYES WITH PLENTY OF WATER FOR AT LEAST 15 MINUTES. CONSULT A PHYSICIAN.

2.3 OPERATION

DO NOT OPERATE DRYER IF THERE IS A LEAK IN EITHER VESSEL. IMMEDIATELY TAKE THE DRYER OUT OF SERVICE AND NOTIFY YOUR CERTIFYING AUTHORITY.

ANY DAMAGE TO THE VESSELS CAN MAKE THEM UNSAFE TO USE. INSPECT OUTSIDE AND INSIDE OF VESSELS REGULARLY FOR CORROSION AND ANY DAMAGE (I.E., DENTS, GOUGES OR BULGES). IF DAMAGED, TAKE OUT OF SERVICE IMMEDIATELY AND NOTIFY YOUR CERTIFYING AUTHORITY.

DO NOT OPERATE THIS DRYER ABOVE THE MAXIMUM RATED WORKING PRESSURE.

OPERATING CONDITIONS FOR PROPER PERFORMANCE OF THIS DRYER ARE DIFFERENT THAN MAXIMUM OPERATING CONDITIONS FOR THE VESSELS. BE SURE TO CHECK THE DRYER OPERATING CONDITIONS. SEE SECTION 3.1.

USE THIS DRYER FOR COMPRESSED AIR ONLY.

AIR FROM THIS DRYER IS NOT SUITABLE FOR BREATHABLE AIR SYSTEMS WITHOUT FURTHER TREATMENT.

DO NOT OPERATE THIS DRYER IF EITHER VESSEL HAS BEEN DAMAGED BY FIRE. TAKE OUT OF SERVICE IMMEDIATELY AND NOTIFY YOUR CERTIFYING AUTHORITY.

2.4 MAINTENANCE

DO NOT REMOVE, REPAIR, OR REPLACE ANY ITEM ON THE DRYER WHILE IT IS UNDER PRESSURE. TURN OFF MAIN POWER TO THE DRYER AND DEPRESSURIZE THE DRYER COMPLETELY BEFORE STARTING INSTALLATION AND/OR MAINTENANCE PROCEDURES.

DO NOT WELD OR GRIND EITHER VESSEL. IT WILL NOT BE SAFE TO OPERATE. (Note: Any uncertified alteration to the vessels VOIDS the ASME Code Certification.)

3.1 DRYER SPECIFICATIONS

WEIGHT (with desiccant installed)

	HL-200	HL-250	HL-375	HL-500	HL-650	HL-800	HL-1000	HL-1250	HL-1500	HL-1750	HL-2000
N4 STANDARD	660 lbs	715 lbs	1035 lbs	1160 lbs	1680 lbs	1830 lbs	2635 lbs	2885 lbs	3870 lbs	4095 lbs	4370 lbs
ALL OTHERS	700 lbs	755 lbs	1075 lbs	1200 lbs	1720 lbs	1870 lbs	2675 lbs	2925 lbs	3910 lbs	4135 lbs	4410 lbs

DIMENSIONS See SECTIONS 3.2 through 3.4

IN/OUT CONNECTION All models have 150# ANSI RF flanged inlet and outlet connections. Bolt holes straddle centerlines.

HL-200	HL-250	HL-375	HL-500	HL-650	HL-800	HL-1000	HL-1250	HL-1500	HL-1750	HL-2000
1-1/2"	1-1/2"	1-1/2"	1-1/2"	2-1/2"	2-1/2"	2-1/2"	2-1/2"	3"	3"	3"

VESSELS (desiccant towers)

Construction Manufactured to the ASME CODE, Section VIII, Division 1.
 Models HL-200 through HL-250 vessels stamped "UM" symbol. Models HL-375 and larger vessels stamped "U" symbol.
 Design Pressure 150 PSIG
 Design Temperature -20°F TO 300°F

PIPING

Threaded fittings: ANSI B16.3
 Threaded unions: ANSI B16.39
 Flanges: ANSI B16.5
 Pipe: Carbon steel, Schedule 40

VALVE

Inlet Proprietary 3-Way piloted shuttle valve
 Outlet Two (2) Check valves, butterfly type
 Purge Normally closed, diaphragm type

CONTROL AIR FILTER

Construction Zinc housing

ELECTRICAL

Standard 115 Volt 115-120V/1PH/50-60Hz
 Optional 230 Volt: Main power: 220-240V/1PH/50-60Hz
 Control power: Transformed to 115-120V/1PH/50-60Hz, on Emcon II units only

DESICCANT

Material Activated Alumina, 1/8" (2-5 MM) Bead type
 Quantity Per Tower (LBS)

HL-200	HL-250	HL-375	HL-500	HL-650	HL-800	HL-1000	HL-1250	HL-1500	HL-1750	HL-2000
106	130	203	266	366	440	560	678	872	986	1119

OPERATING CONDITIONS

Inlet Air Pressure MIN 60 PSIG MAX 150 PSIG
 Inlet Air Temperature MIN 40°F MAX 120°F
 Ambient Air Temperature MIN 40°F MAX 120°F

RATED INLET CONDITIONS

Inlet Air Pressure 100 PSIG
 Inlet Air Temperature 100°F
 Relative Humidity (saturation) 100% RH

FLOW CAPACITIES (SCFM) at various pressures (100°F)

	60 PSIG	80 PSIG	100 PSIG	110 PSIG	125 PSIG	140 PSIG	150 PSIG
HL-200	130	165	200	209	221	232	240
HL-250	163	206	250	261	276	290	300
HL-375	244	310	375	391	414	436	449
HL-500	326	413	500	521	552	581	599
HL-650	423	537	650	678	717	755	779
HL-800	521	661	800	834	883	929	959
HL-1000	651	826	1000	1043	1104	1161	1198
HL-1250	814	1032	1250	1303	1380	1452	1498
HL-1500	977	1238	1500	1564	1655	1742	1797
HL-1750	1140	1445	1750	1825	1931	2032	2097
HL-2000	1303	1651	2000	2085	2207	2323	2397

3.2 DIMENSIONS Models HL-200 through HL-800

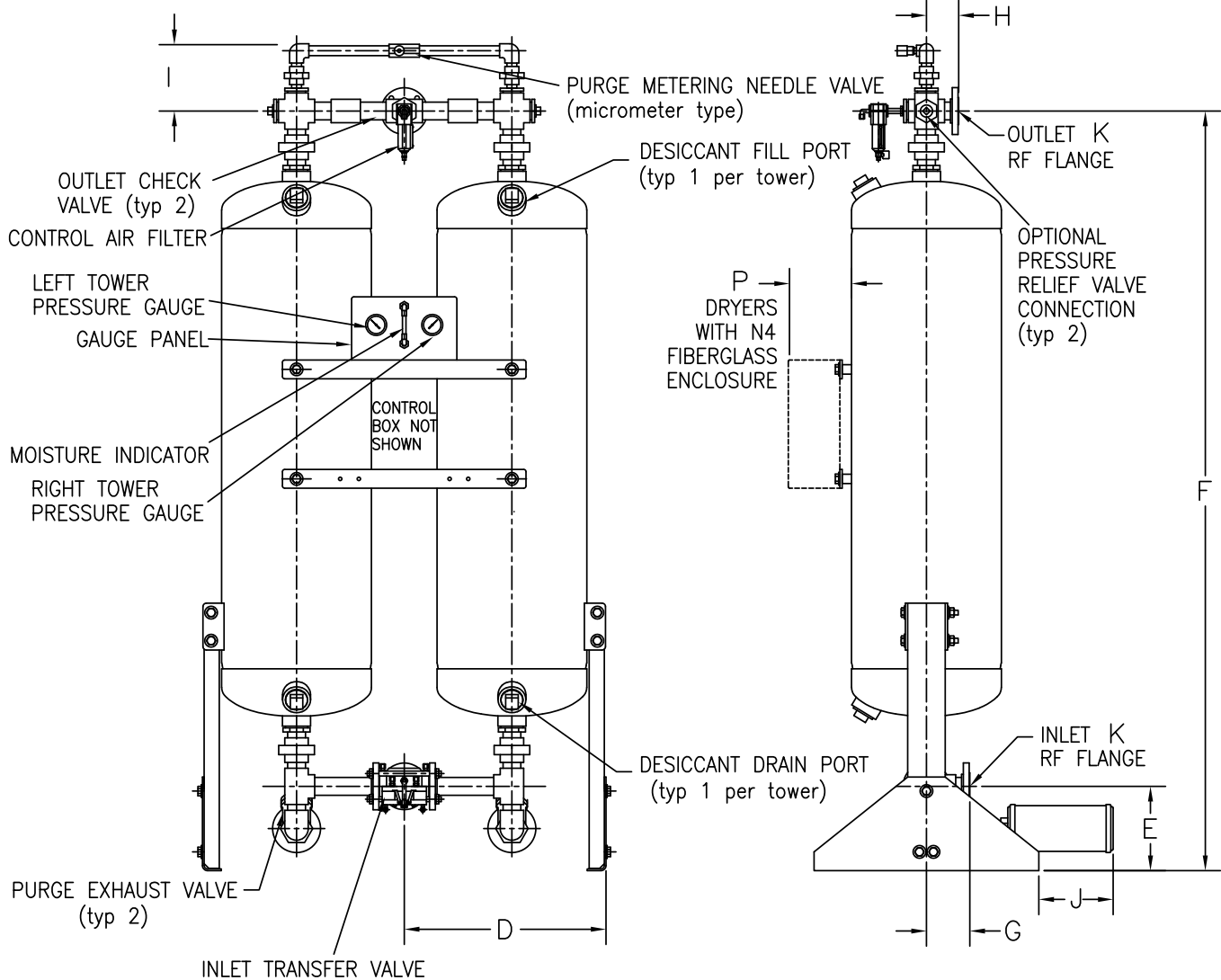
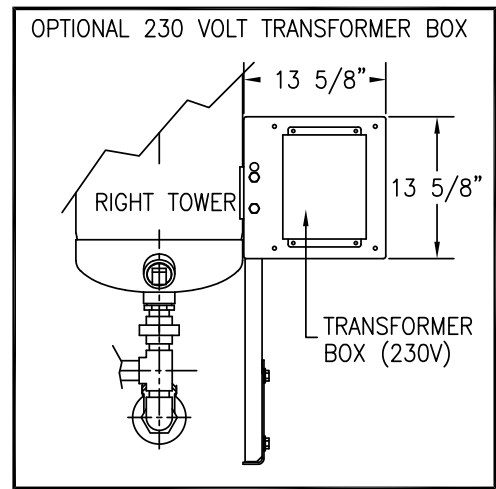
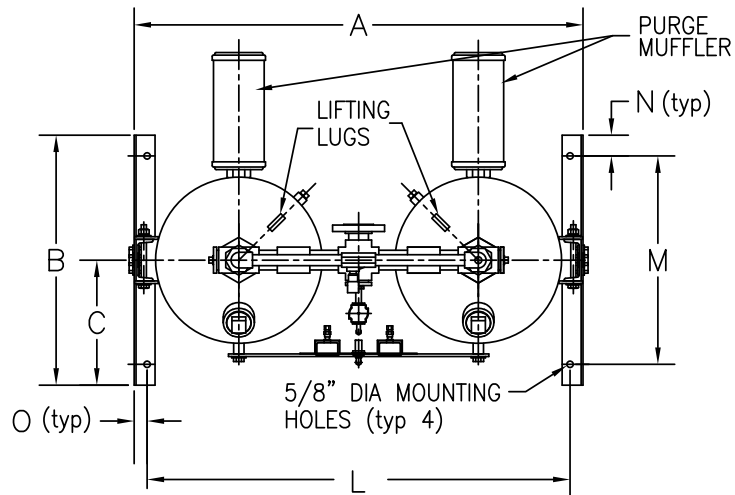

	A	B	C	D	E	F	G	H	I	J	K	L	M	N	O	P	Q
HL-200	37.50	24.00	12.00	18.75	9.00	84.38	4.38	3.38	3.75	3.25	1-1/2	35.00	20.00	2.00	1.25	8.50	.50
HL-250	37.50	24.00	12.00	18.75	9.00	84.38	4.38	3.38	3.75	3.25	1-1/2	35.00	20.00	2.00	1.25	8.50	.50
HL-375	43.13	24.00	12.00	21.57	9.00	81.13	4.38	3.38	7.25	8.00	1-1/2	40.63	20.00	2.00	1.25	8.50	1.00
HL-500	43.13	24.00	12.00	21.57	9.00	81.13	4.38	3.38	7.25	8.00	1-1/2	40.63	20.00	2.00	1.25	8.50	1.00
HL-650	53.75	36.00	18.00	26.88	16.75	95.25	5.50	4.00	8.00	13.25	2-1/2	50.50	32.00	2.00	1.63	8.50	1.50
HL-800	53.75	36.00	18.00	26.88	16.75	95.25	5.50	4.00	8.00	13.25	2-1/2	50.50	32.00	2.00	1.63	8.50	1.50

3.3 DIMENSIONS Models HL-1000 through HL-1250

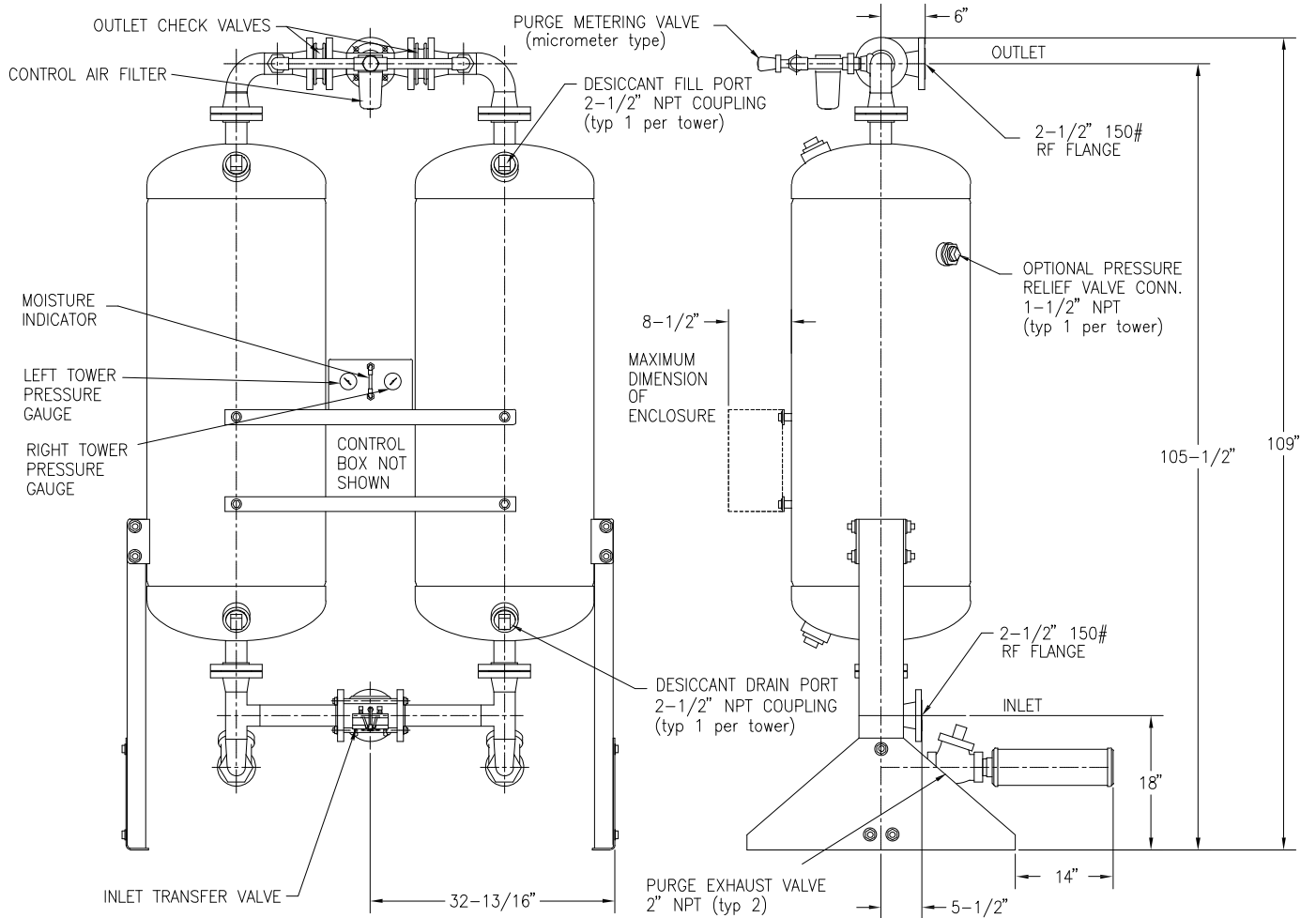
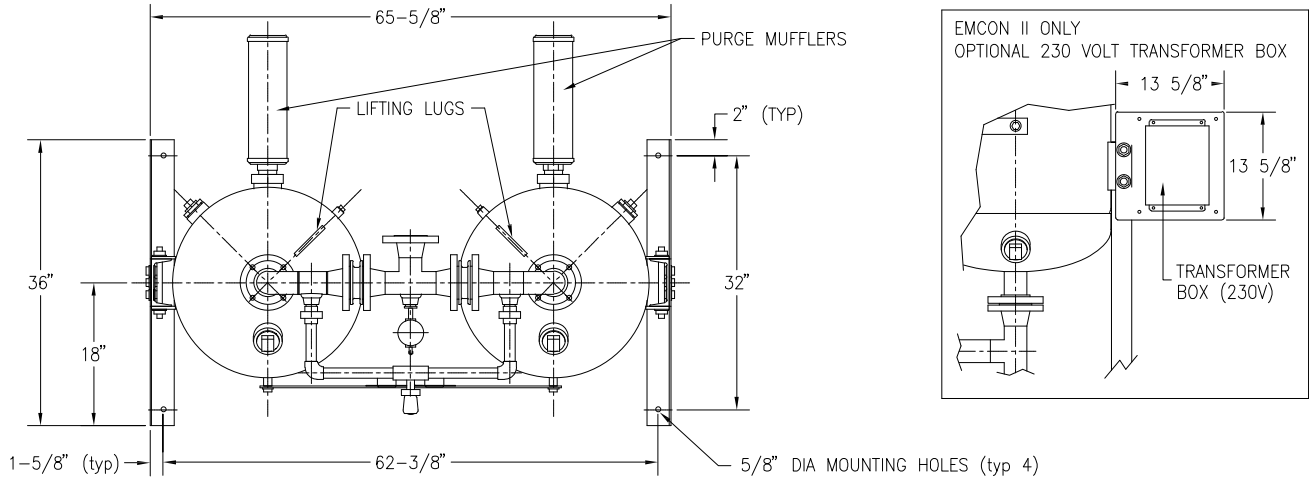

3.4 DIMENSIONS Models HL-1500 through HL-2000

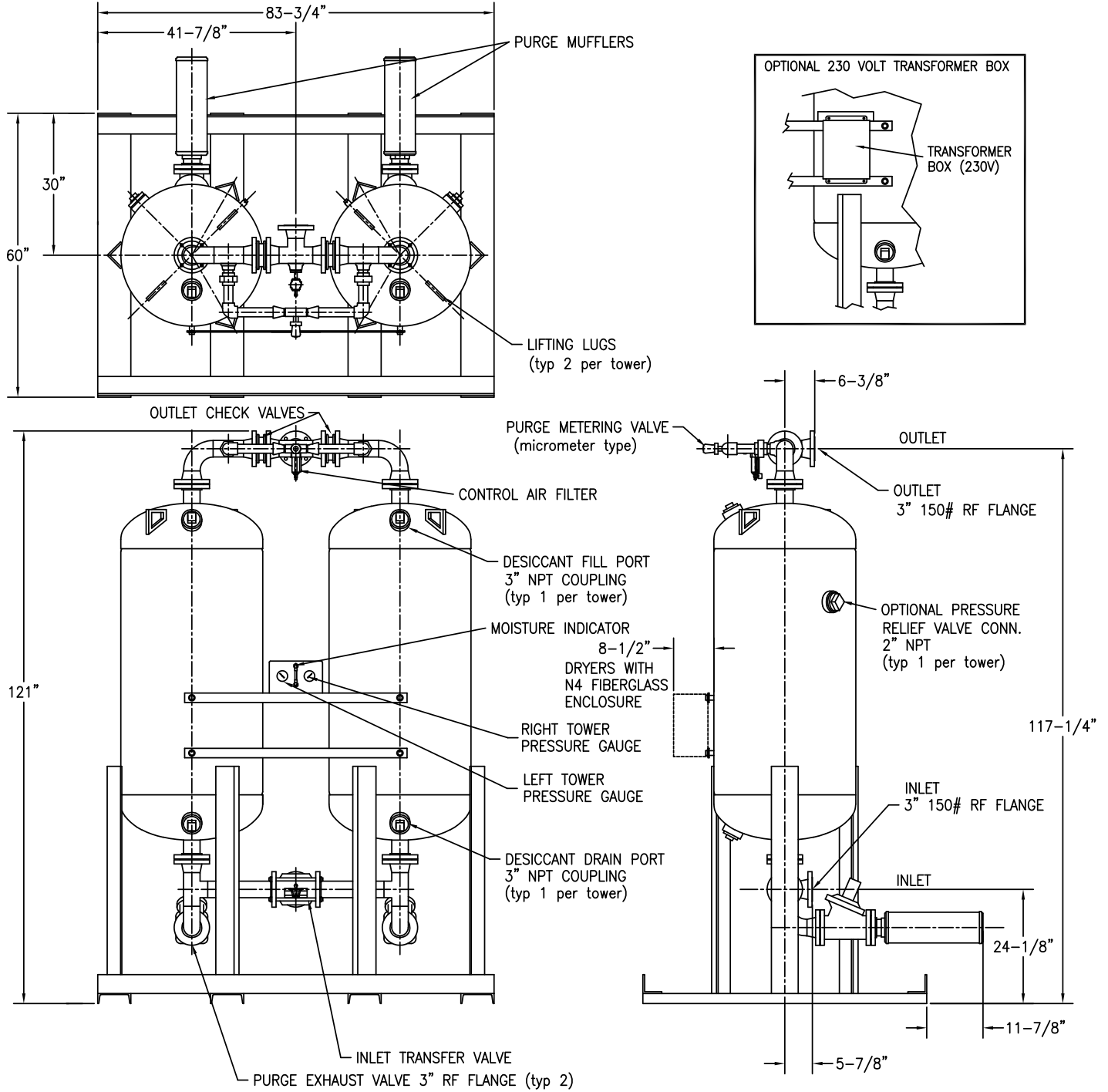

4.1 LOCATION

WARNING

DO NOT INSTALL THIS DRYER IN AN ENVIRONMENT OF CORROSIVE CHEMICALS, EXPLOSIVE GASSES, POISONOUS GASSES, OR SATURATED STEAM HEAT.

Locate dryer in a protected, well vented area where ambient temperatures are between 40°F and 120°F. Allow sufficient clearance over and around the dryer for access to desiccant fill and drain ports and controls. **Refer to SECTIONS 3.2 through 3.4 for dryer dimensions.**

If this dryer must be installed where ambient temperatures are below 40°F, insulation and heat tracing must be properly installed on the inlet piping, purge exhaust line and the desiccant towers to prevent freezing of the equipment.

Position the dryer in the upright position on a solid, level, vibration free surface capable of supporting the dryer's weight. **Refer to SECTION 3.1 for dryer specifications.**

The dryer should not be located in extremely dirty areas where airborne contaminants can accumulate on the dryer. If this cannot be prevented, the dryer should be cleaned periodically. An accumulation of dirt on the dryer may cause the inlet transfer valve to fail.

4.2 PIPING AND ANCILLARY EQUIPMENT

CAUTION

Make sure that the inlet air piping is connected at the bottom and the outlet air piping is connected at the top of the dryer.

Make sure that the inlet and outlet piping to and from the dryer is properly supported. Excessive stress may cause damage and/or dryer malfunction.

Remove protective caps or covers from all valves before installing this dryer.

If this dryer is to be installed into an existing piping system, clean the existing inlet piping to remove all accumulated dirt, pipe scale, etc., before connecting the dryer. Make sure that the inlet and outlet shutoff valves are tightly closed before connecting to the existing piping system.

If excessive vibrations are present in the piping, install a flexible hose between the compressor and the dryer inlet.

When installing the piping and any additional components, make sure that adequate pipe supports are used. Excessive stress on the dryer and components may cause damage or premature failure. Use either overhead or stiff-leg type supports.

Make sure that the piping is correctly connected to the dryer. The inlet is the bottom connection and the outlet is the top connection. **Reference SECTIONS 3.2 through 3.4 for dryer dimensions and connection locations.**

Once the location has been determined, place the dryer into position. Lift the dryer by the lifting lugs only. **Reference SECTION 1 for handling instructions.**

When the dryer is in place, it can be fastened to the mounting surface. **Reference SECTIONS 3.2 through 3.4 for dryer dimensions.**

4.2-1 BYPASS PIPING (optional)

The installation of bypass piping is not required, but will allow the dryer and filter(s) to be taken off stream without interrupting the air system.

In Figure 4A, several recommended bypass piping layouts and additional components are shown.

Basic bypass piping should include an inlet isolation valve, a bypass valve, and an outlet isolation valve. The isolation and bypass valves must be bubble-tight.

4.2-2 FILTERS

CAUTION

A PROPERLY RATED COALESCING PREFILTER MUST BE INSTALLED BEFORE THE DRYER TO REMOVE LUBRICATING OILS, DUST AND PIPE SCALE CONTAMINATION. FAILURE TO USE A PREFILTER WILL RESULT IN DAMAGE TO THE DRYER AND Voids THE WARRANTY.

Make sure that the elements are installed in all filter housings prior to start up.

THE DRYER AND PREFILTER ARE NOT DESIGNED TO HANDLE LIQUID WATER. IF LIQUID WATER IS PRESENT IN THE AIR SYSTEM, A SEPARATOR WITH AN AUTOMATIC DRAIN MUST BE INSTALLED UPSTREAM TO THE PREFILTER AND DRYER TO PREVENT FLOODING.

A coalescing prefilter must be installed before the dryer to remove lubricating oils, dust and pipe scale contamination. It is recommended that a high efficiency coalescing filter with an automatic drain or electric drain valve be installed. The filter should be equipped with a pressure differential indicator to monitor the condition of the element.

A particulate afterfilter should be installed downstream of the dryer to remove any desiccant dust. The filter should be equipped with a pressure differential indicator to monitor the condition of the element.

Make sure that the filters are properly installed according to the instructions provided with them.

4.3 INSTALLING THE PRESSURE RELIEF VALVES

CAUTION

THESE ASME CODE VESSELS MUST BE PROTECTED BY PRESSURE RELIEF VALVES. Refer to OSHA 1910.169 Par. b, Sub. Par (3) and ASME Boiler and Pressure Vessel Code, Section VIII, Division 1, UG-125 through UG-136. Also check government regulations, i.e., state and local codes.

Connections are provided in the outlet piping for the installation of pressure relief valves. Reference SECTIONS 3.2 through 3.4 for location and connection size.

Install the pressure relief valves into the provided connections. If pressure relief valves were not purchased with the dryer, the following valve sets are available from your local VAN AIR representative.

DRYER MODEL	VALVE PART NO.
HL-200	14-1448 (2)
HL-250	14-1448 (2)
HL-375	14-1833 (2)
HL-500	14-1833 (2)
HL-650	14-1834 (2)
HL-800	14-1834 (2)
HL-1000	14-1835 (2)
HL-1250	14-1835 (2)
HL-1500	14-1836 (2)
HL-1750	14-1836 (2)
HL-2000	14-1836 (2)

FIGURE 4A RECOMMENDED PIPING CONFIGURATIONS AND COMPONENTS

3 VALVE BYPASS

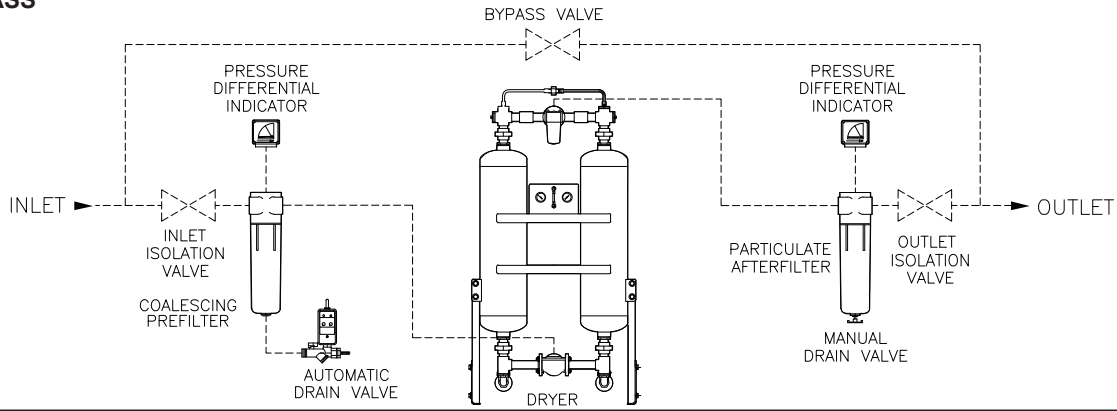

9 VALVE BYPASS

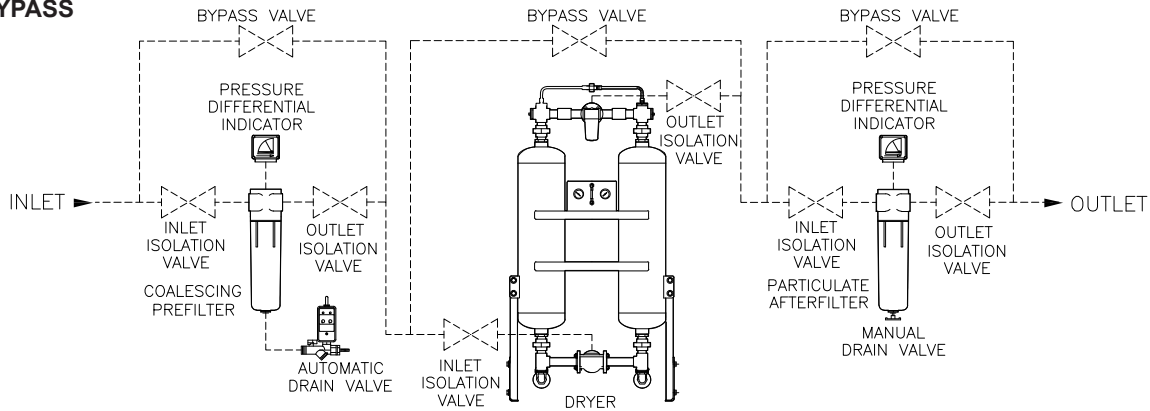

11 VALVE BYPASS

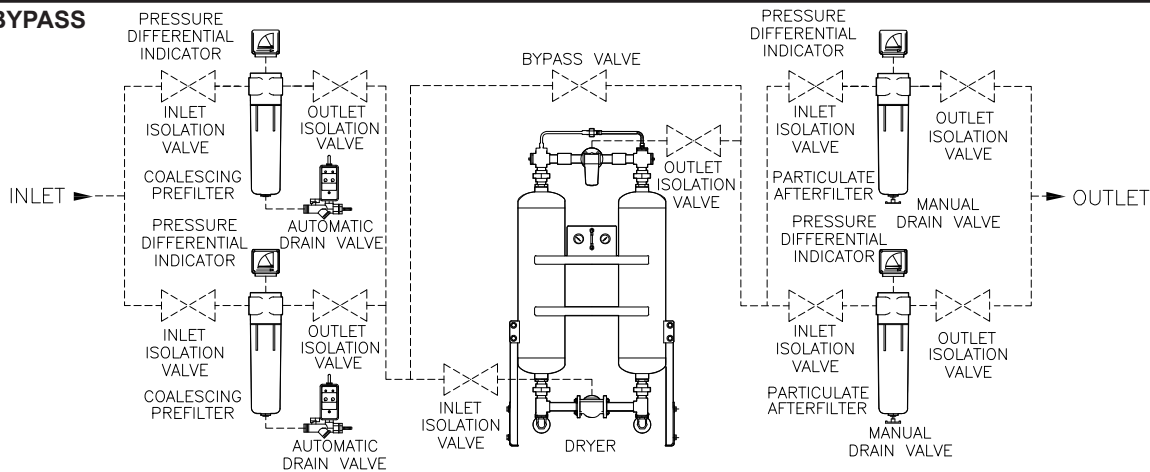

DRYER		PREFILTER		DRAIN VALVE MODEL	DEL-P IND. MODEL	AFTERFILTER		DEL-P IND. MODEL
MODEL	IN/OUT	MODEL	IN/OUT			MODEL	IN/OUT	
HL-200	1-1/2" RF FLG	F200-265-1/4-C	1-1/4" NPT(F)	EDV-115	PD-5	F200-265-1/4-RB	1-1/4" NPT(F)	PD-5
HL-250	1-1/2" RF FLG	F200-265-1/4-C	1-1/4" NPT(F)	EDV-115	PD-5	F200-265-1/4-RB	1-1/4" NPT(F)	PD-5
HL-375	1-1/2" RF FLG	F200-350-1/2-C	1-1/2" NPT(F)	EDV-115	PD-5	F200-350-1/2-RB	1-1/2" NPT(F)	PD-5
HL-500	1-1/2" RF FLG	F200-500-2-C	2" NPT(F)	EDV-115	PD-5	F200-500-2-RB	2" NPT(F)	PD-5
HL-650	2-1/2" RF FLG	F200-600-3-C	3" NPT(F)	EDV-115	PD-5	F200-600-3-RB	3" NPT(F)	PD-5
HL-800	2-1/2" RF FLG	F200-800-3-C	3" NPT(F)	EDV-115	PD-5	F200-800-3-RB	3" NPT(F)	PD-5
HL-1000	2-1/2" RF FLG	F200-1000-3-C	3" NPT(F)	EDV-115	PD-5	F200-1000-3-RB	3" NPT(F)	PD-5
HL-1250	2-1/2" RF FLG	F200-1600-3-C	3" NPT(F)	EDV-115	PD-5	F200-1600-3-RB	3" NPT(F)	PD-5
HL-1500	3" RF FLG	F200-1600-3-C	3" NPT(F)	EDV-115	PD-5	F200-1600-3-RB	3" NPT(F)	PD-5
HL-1750	3" RF FLG	F101-2000-C	4" RF FLG	EDV-115	PD-2	F101-2000-RB	4" RF FLG	PD-2
HL-2000	3" RF FLG	F101-2000-C	4" RF FLG	EDV-115	PD-2	F101-2000-RB	4" RF FLG	PD-2

4.4 REMOTE PURGE EXHAUST PIPING

To reduce noise during purging and tower depressurization, this dryer was supplied with mufflers for installation on the purge exhaust valves. If the sound or humidity discharged from the dryer is unacceptable, the purge of this dryer can be remotely piped away.

IMPORTANT

Make sure that the piping is as short as possible and does not create back pressure on the dryer. To prevent liquid accumulation in the piping and purge valves, the piping must be at the same level or lower than the purge valves.

The purge line must be vented to atmospheric pressure. If the ambient temperature at the venting end of the piping is subject to temperatures below 40°F, freeze protection must be installed.

The purge valves have threaded pipe connections. Reference Sections 3.2 through 3.4 for location. Use adequate pipe supports to prevent stress on valves.

The distance will determine the size of piping that is recommended. For distances of 10 feet or less, use piping of the same size as the purge valves. For distances up to 20 feet, use piping one size larger than the purge valves.

4.5 INSTALLING THE PURGE MUFFLERS

To reduce the sound level during purge and tower depressurization, this dryer was supplied with mufflers for installation on the purge exhaust valves.

Mufflers were shipped separately. They should **NOT** be installed until the dryer has been operated for several hours. From desiccant installation, some dust may be present in the desiccant towers. Operating the dryer with the mufflers installed immediately after the towers have been filled with the desiccant or during initial start up may cause the mufflers to clog.

IMPORTANT

The dryer must be operated for several hours without the mufflers after the towers have been filled with desiccant. This will prevent the mufflers from becoming clogged.

FIGURE 4B PURGE MUFFLER INSTALLATION

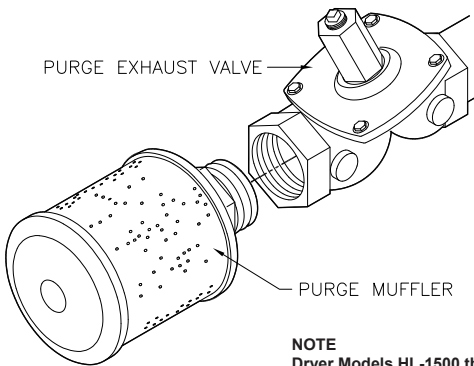

4.6 ELECTRICAL CONNECTIONS

WARNING

SERIOUS PERSONAL INJURY AND DAMAGE TO THE DRYER WILL OCCUR IF THE DRYER IS CONNECTED TO A POWER SOURCE OTHER THAN THE VOLTAGE LISTED ON THE DATA TAG.

WHEN INSTALLING THE ELECTRICAL CONNECTIONS FOR THIS DRYER, COMPLY WITH NATIONAL ELECTRICAL CODE AND ALL APPLICABLE FEDERAL, STATE AND LOCAL CODES

4.6-1 STANDARD CONTROL BOX (115V & 230V)

The power supply to the dryer is to be connected to the dryer control box. A 7/8" dia hole was provided in the bottom of the box for the connection of conduit or a cord grip connector.

Check the electrical rating of the dryer as listed on the dryer data tag. Make sure that the power source is correct for the dryer rating.

Remove the box cover to access the power and alarm terminals. Wire the power supply as shown in Figure 4C (Standard Control Box). Connect the wiring to the dryer box. Comply with all codes applicable for this installation.

FIGURE 4C ELECTRICAL CONNECTIONS (STANDARD CONTROL BOX)

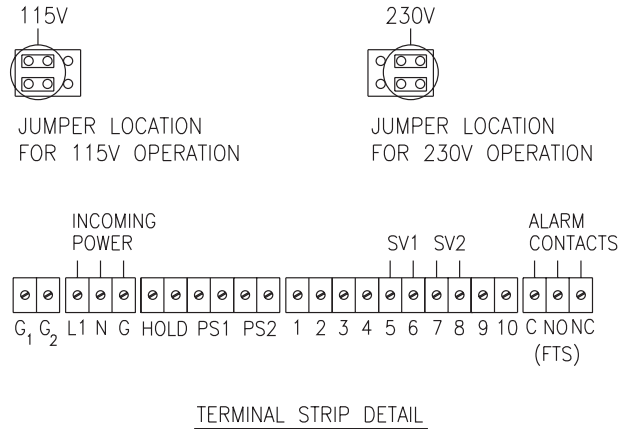

Control Power: 115V /1PH/50-60Hz; 230V/1PH/50-60Hz
 Max amp draw: 0.3 AMPS; 0.15 AMPS
 General Alarm Contacts: 115V-230V/1PH/60Hz, 0.25 amps

4.6-2 CYCLE SAVER / FAILURE TO SWITCH (115V & 230V)

Same instructions as Standard Control Box except wire the power supply as shown in Figure 4D (Cycle Saver / Failure To Switch).

FIGURE 4D ELECTRICAL CONNECTIONS (CYCLE SAVER / FAILURE TO SWITCH)

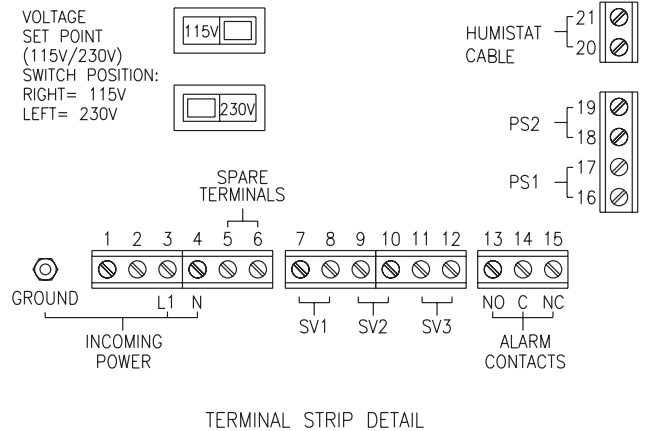

Control Power: 115V /1PH/50-60Hz; 230V/1PH/50-60Hz
 Max amp draw: 1 AMPS; 0.5 AMPS
 General Alarm Contacts: 115V-230V/1Ph/60Hz, 3 amps

4.6-3 EMCON II (115 VOLT)

The electrical controls for the Emcon II dryers are housed in a NEMA 4 rated fiberglass enclosure.

Reference **Figure 4E** to locate the power input terminals. Access into the enclosure for wiring and conduit can be made by carefully drilling a hole in the bottom of the enclosure.

IMPORTANT
 Do NOT wire the power supply directly to the PLC. Wire the power supply to the input terminals as shown in **Figure 4E**.

Connect the proper conduit and wiring as required for this installation by all applicable codes.

Make the necessary connections to the power input terminals.

FIGURE 4E ELECTRICAL CONNECTIONS EMCON II (115 VOLT)

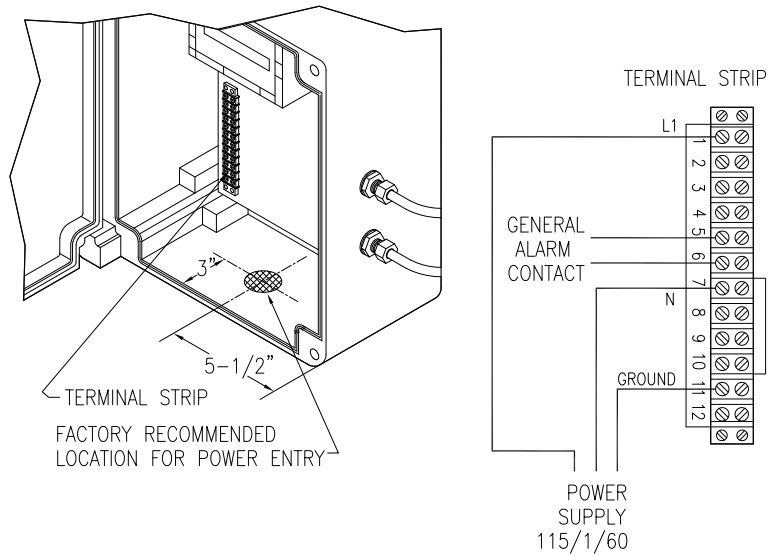

Control Power: 115V/1PH/60Hz
Max amp draw: 2 AMPS
General Alarm Contacts: 115V-230V/1PH/60Hz, 2 amps

4.6-4 EMCON II (230 VOLT)

The main electrical controls for the Emcon II dryers are housed in a NEMA 4 rated fiberglass enclosure.

Dryers rated for 230V/1PH/60Hz are equipped with a power transformer located in a separate enclosure on the dryer. All main power supply (230V) connections will be made in the transformer enclosure.

Reference **Figure 4F** for connection details. Connect to the enclosure using the proper conduit and wiring as required for this installation by all applicable codes.

FIGURE 4F ELECTRICAL CONNECTIONS EMCON II (230 VOLT)

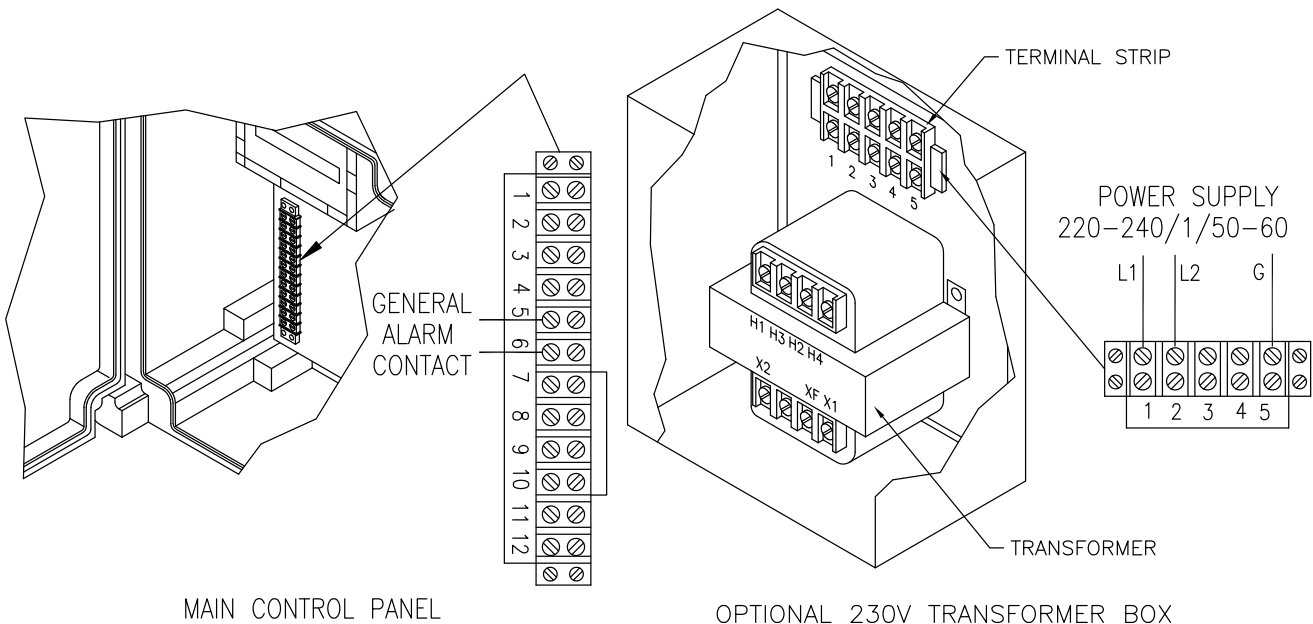

General Alarm Contacts: 115V-230V/1PH/60Hz, 2 amps

5.1 START UP

WARNING

BEFORE STARTING THIS DRYER, FOLLOW THE INSTALLATION INSTRUCTIONS AND PROCEDURES COMPLETELY. SERIOUS PERSONAL INJURY CAN RESULT IF INSTRUCTIONS ARE NOT CAREFULLY AND COMPLETELY FOLLOWED.

DO NOT REMOVE, REPAIR, OR REPLACE ANY ITEM ON THIS DRYER WHILE IT IS UNDER PRESSURE.

For the Standard Control Box, make sure the Stop button is pressed. For the Cycle Saver and Emcon II Control Boxes, make sure that the Power ON/OFF switch is in the **OFF** position.

If the dryer is being started up for the first time or after the desiccant has been changed, the purge mufflers must be removed. The dryer should be operated until no desiccant dust is visible at the purge valves. Then the mufflers can be reinstalled. See Section 2.2 for safety precautions concerning the desiccant dust.

WARNING

WHEN OPERATING THIS DRYER WITHOUT THE MUFFLERS INSTALLED, USE HEARING PROTECTION.

If bypass piping was installed on this dryer as outlined in SECTION 4.2, close the inlet and outlet isolation valves. Open the bypass valve.

Pressurize the air system. Once the air system is pressurized, slowly open the inlet isolation valve. **DO NOT** open the outlet isolation valve.

To start the dryer with a Standard Control Box, press the Run button which will light the Run LED. For Cycle Saver and Emcon II Control Boxes, place the Power ON/OFF switch in the **ON** position. One tower will already be pressurized. The other tower will depressurize. The purge valve on the tower that is not pressurized will be open, air should be exhausting from the muffler.

Dryers equipped with CYCLE SAVER or EMCON II controls will begin a 20 minute start up cycle. While in the start up cycle the dryer will operate for 5 minutes on each tower to allow the humstat(s) to reach equilibrium. Any time the dryer is restarted after a loss of power or pressure in both towers, it will restart in the start up cycle.

The dryer is equipped with a purge metering valve. The setting should be checked before placing the dryer on stream.

5.2 ADJUSTING THE PURGE FLOW

IMPORTANT

NEVER OPERATE THE DRYER WITH THE PURGE METERING VALVE CLOSED. IF THE VALVE IS CLOSED, THE TOWERS WILL NOT REPRESSURIZE AND SWITCHING FAILURE WILL OCCUR.

DO NOT ADJUST THE PURGE METERING VALVE ABOVE OR BELOW THE RECOMMENDED SETTING FOR THE OPERATING CONDITIONS OF THIS INSTALLATION. IMPROPER SETTING MAY CAUSE POOR DRYER PERFORMANCE AND/OR EXCESSIVE USE OF PROCESS AIR.

The purge flow can be adjusted for the operating conditions. Standard dryers are equipped with a micrometer type needle valve. The valve can be adjusted to the desired setting.

This dryer was shipped with the purge flow set for the rated inlet flow at 100 PSIG. Reference Section 3.1 for rated flow. This setting should be correct for most installations. Before placing the dryer on stream, check the purge metering valve setting.

Figure 5B shows the purge flow required for each model. This flow is required to properly regenerate the desiccant beds.

If the dryer is being operated at a pressure other than inlet rated

conditions, the purge metering valve must be adjusted to maintain the required purge flow rate listed in Figure 5B.

Determine the dryer minimum operating pressure. Using the chart in Figure 5A, find the valve setting for that pressure. The valve is equipped with a set screw which must be loosened before the valve is adjusted. Adjust the needle valve to the desired setting. Tighten the set screw to prevent tampering.

FIGURE 5A PURGE METERING VALVE SETTINGS

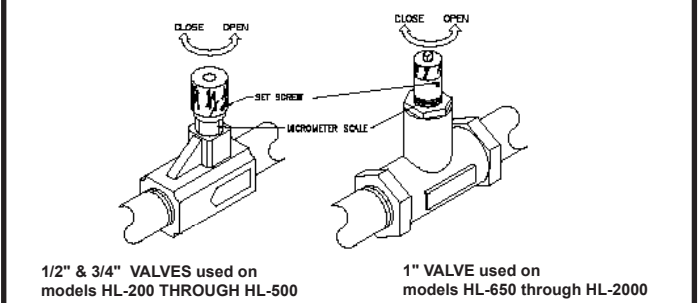

	FACTORY SETTING				
MODEL	60 PSIG	80 PSIG	100 PSIG	120 PSIG	150 PSIG
HL-200	3.5 turns	3.3 turns	3.2 turns	3.1 turns	3.0 turns
HL-250	3.6 turns	3.4 turns	3.3 turns	3.2 turns	3.1 turns
HL-375	4.5 turns	4.0 turns	3.8 turns	3.7 turns	3.5 turns
HL-500	5.6 turns	4.6 turns	4.2 turns	4.0 turns	3.8 turns
HL-650	2.7 turns	2.6 turns	2.5 turns	2.3 turns	2.2 turns
HL-800	2.8 turns	2.7 turns	2.6 turns	2.5 turns	2.3 turns
HL-1000	3.0 turns	2.8 turns	2.7 turns	2.6 turns	2.5 turns
HL-1250	3.4 turns	3.0 turns	2.9 turns	2.7 turns	2.6 turns
HL-1500	3.8 turns	3.3 turns	3.0 turns	2.9 turns	2.7 turns
HL-1750	4.0 turns	3.5 turns	3.2 turns	3.0 turns	2.8 turns
HL-2000	4.2 turns	3.9 turns	3.4 turns	3.2 turns	3.0 turns

FIGURE 5B REQUIRED PURGE FLOW

DRYER MODEL	PURGE FLOW	DRYER MODEL	PURGE FLOW
HL-200	36.0 SCFM	HL-1000	180.0 SCFM
HL-250	45.0 SCFM	HL-1250	225.0 SCFM
HL-375	67.5 SCFM	HL-1500	270.0 SCFM
HL-500	90.0 SCFM	HL-1750	315.0 SCFM
HL-650	117.0 SCFM	HL-2000	360.0 SCFM
HL-800	144.0 SCFM		

5.3 CONDITIONING THE DESICCANT BED

To condition the desiccant bed, the dryer is operated without any outlet flow, while the towers regenerate with purge air.

To start the dryer with a Standard Control Box, press the Run button which will light the Run LED. For Cycle Saver and Emcon II Control Boxes, place the Power ON/OFF switch to the **ON** position.

Dryers equipped with the Standard Control Box should be set on the 10 minute time cycle. Dryers equipped with Emcon II and Cycle Saver should be set in the Fixed Mode. Observe the dryer for several cycles. Make sure that it is operating properly.

At initial start up or after extended shutdowns (over one month), the dryer may take 24 to 48 hours of continuous operation for the bed to be conditioned. Moisture that has accumulated on the desiccant bed should be removed before the dryer is placed on stream.

Once the moisture indicator on the dryer turns blue, the desiccant bed is ready. Place the dryer on stream by opening the outlet isolation valve. Make sure that the by-pass valve is closed.

6.1 PRINCIPLE OF OPERATION

HL Series Heatless Regenerative Air Dryers utilize the pressure swing principle of operation. The desiccant bed in one tower dries the air stream while the desiccant bed in the other tower is regenerated.

A purge of dry air is used for tower regeneration. It is taken from the outlet of the dryer.

The dryer is equipped with a purge metering valve to allow the correct amount of dry air to flow into the regenerating tower. The heat created during adsorption of moisture in the drying tower is retained in the desiccant bed and increases the moisture removal capacity of the purge air.

The timing cycle of the dryer is controlled by two 3-way pilot valves.

A patented shuttle valve system is used to repressurize, changeover, and depressurize the towers. The inlet transfer valve is controlled by the pilot valves. The movement of the shuttle in the inlet transfer valve mechanically actuates the external pneumatic limit switches, which open the purge valves and depressurize the tower. The shuttle cannot shift until the tower pressures are nearly equal. The dryer cannot depressurize until the shuttle has fully seated and the one of the limit switches is engaged.

To achieve maximum performance from this dryer, it should be operated continuously. Operating this dryer for single shift periods may result in varied outlet dew point performance.

The dryer operation consists of four stages; REPRESSURIZATION, CHANGEOVER/DEPRESSURIZATION, DRYING and REGENERATION.

6.1-1 REPRESSURIZATION STAGE

Repressurization occurs in the regenerating tower. Repressurization must occur before tower changeover. This reduces shock to the desiccant and the possibility of downstream pressure spikes.

The purge valve is closed and the purge air, which was vented to atmosphere earlier in the cycle, is now used to repressurize the regenerated tower.

The pilot valves SV1 & SV2 de-energize causing the purge valve on the regenerating tower to close. The purge air, which was vented to atmosphere earlier in the cycle, is now used to repressurize the regenerated tower.

FIGURE 6A PNEUMATIC SCHEMATIC for DRYERS WITH STANDARD CONTROL

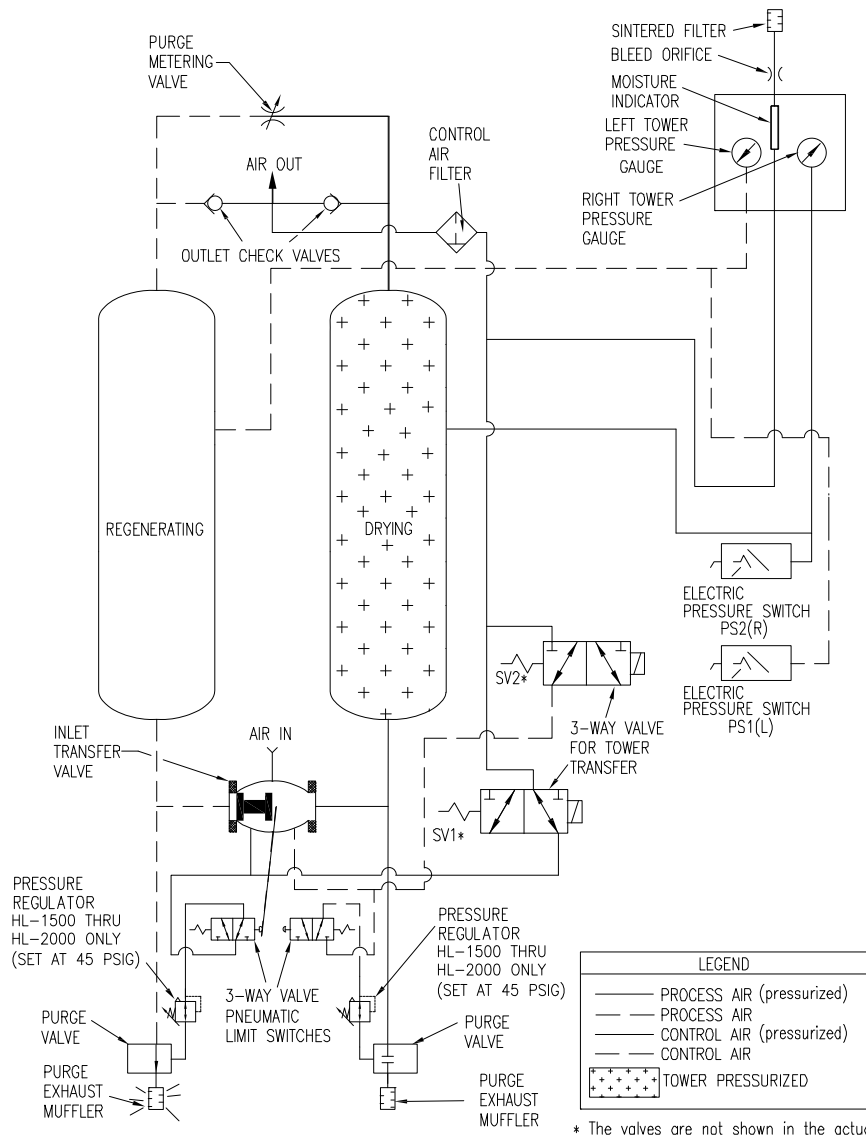

* The valves are not shown in the actual order.

6.1-2 CHANGEOVER/DEPRESSURIZATION STAGE

Tower changeover occurs after the previous regenerating tower is pressurized. The controller signals the inlet transfer valve to switch. The tower that was on line and drying the process air will begin to depressurize.

Pressure in the regenerating tower will approach full line pressure. The pilot valves SV1 or SV2 will energize. Pilot air will be supplied to one side of the inlet transfer valve. The inlet transfer valve shuttle will move to the side that has pilot pressure.

When the inlet transfer valve changes position, the position indicator will move and actuate the other pneumatic limit switch. This will open the purge valve on the tower that was drying the process air, causing the tower to depressurize.

CYCLE SAVER and EMCON II models:

If the dryer is being operated in the AUTO MODE, tower changeover is delayed until the dew point controller(s) signal the circuit board or PLC. The dryer will automatically change towers after 4 hours of ENERGY SAVINGS.

6.1-3 DRYING AND REGENERATION STAGE

During the drying stage, one tower is pressurized with process air. This tower is in the drying stage. The process air passes through the desiccant bed, which adsorbs moisture from the air. The regeneration stage of one tower occurs at the same time as the drying stage in the opposite tower. During the regeneration stage, a percentage of dry air is directed through the desiccant bed of the offstream tower. The purge air is vented through the purge valve to the atmosphere.

The pilot valves SV1 or SV2 are either energized or de-energized depending on which tower is on stream (drying). If SV2 is energized, the LEFT tower is drying and if SV1 is energized, the RIGHT tower is drying.

6.2 MOISTURE INDICATOR

The moisture indicator is in the center of the panel. The moisture indicator is a clear plastic tube filled with moisture sensing crystals. A sample of outlet air is directed through the indicator.

The crystals will change colors from PINK (indicating wet air) to BLUE (indicating dry air) as the dew point of the air changes from +20°F to -40°F.

FIGURE 6B PNEUMATIC SCHEMATIC for DRYERS WITH CYCLE SAVER OR EMCON II

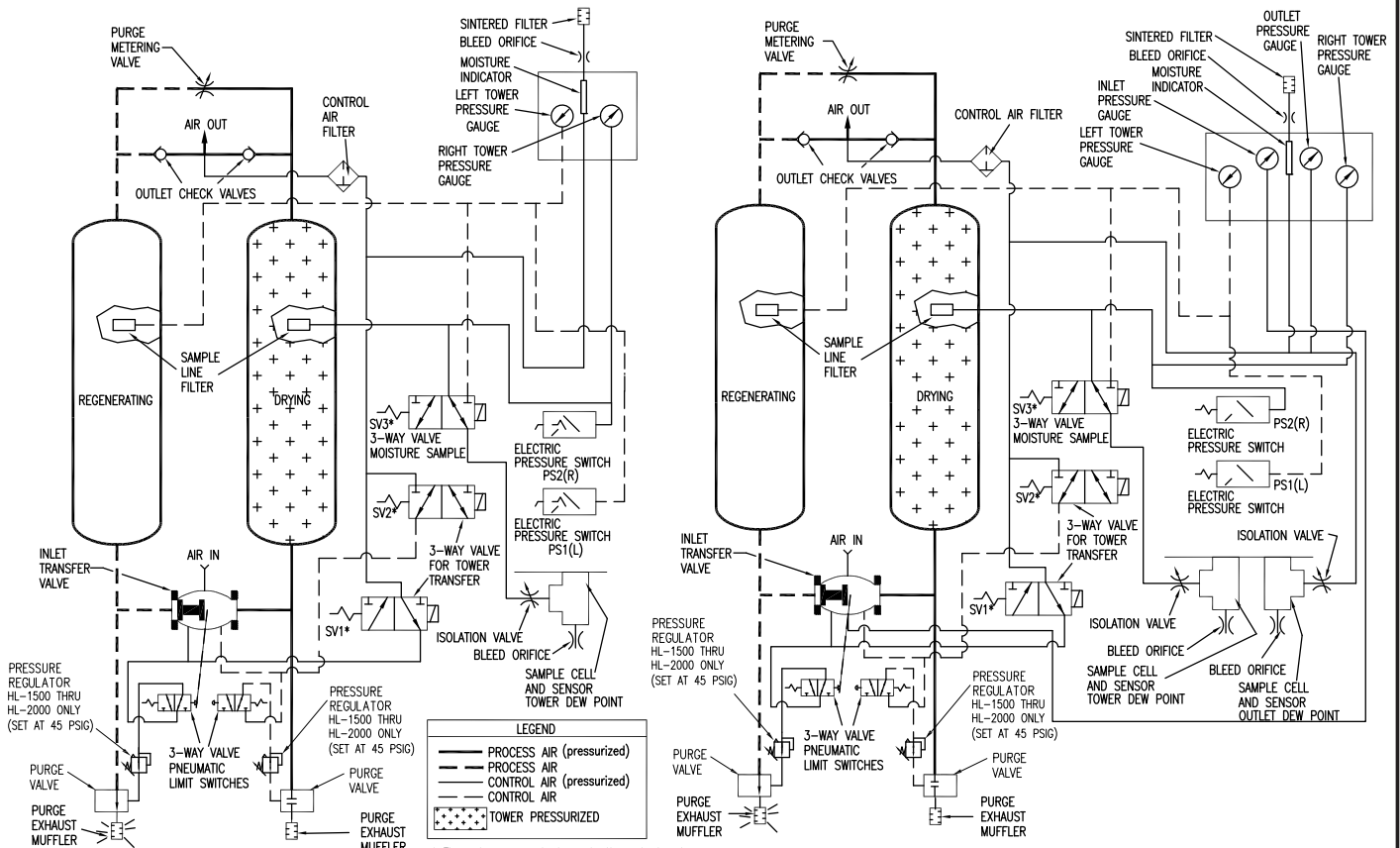

Pneumatic schematic shown above for units equipped with CYCLE SAVER.

Pneumatic schematic shown above for units equipped with PLC controls featuring EMCON II.

7.1 STANDARD CONTROL

The STANDARD CONTROL is a compact NEMA 4X control box. It has the following features:

- Dryer Status LEDs
 - POWER ON LED
 - RUN LED
 - HOLD LED
 - SWITCHING FAILURE LED
 - L/R TOWER DRYING LED
 - L/R TOWER REGENERATING LED
 - DRYER PURGING LED

The Dryer Status LEDs are located on the front panel of the control box. Figure 7A shows the location of each. **Note: There is a Red LED located on the inside of the control box. This LED flashes on and off indicating the timer is active.**

Start the dryer per SECTION 5.1. When the Left tower is pressurized and on line drying the process air, the corresponding LEFT TOWER DRYING LED is illuminated. When the right tower is pressurized and on line drying the process air, the corresponding RIGHT TOWER DRYING LED is illuminated. The DRYER PURGING LED is illuminated when the corresponding purge exhaust valve is open. During repressurization this LED will not be illuminated. Repressurization occurs for approximately 20 seconds just before tower changeover. The operation timing sequence of the dryer is shown in Figure 7C TIMING CHART FOR STANDARD CONTROL.

SWITCHING FAILURE:

When there is a switching failure, the LED will be lit. This will energize the contacts shown in Figure 4C. The contacts can be wired for remote annunciation. To reset the Switching Failure Alarm press the Run button on the control box front panel.

HOLD FEATURE:

For Low load or Static pressure conditions, the hold contacts shown on Figure 4C can be wired to an auxiliary set of normally closed contacts on the compressor starter. This will stop the cycling of the dryer and repressurize both towers of the dryer, until there is demand on the compressor. The Hold LED will light, if the dryer is wired as described and the compressor is not running.

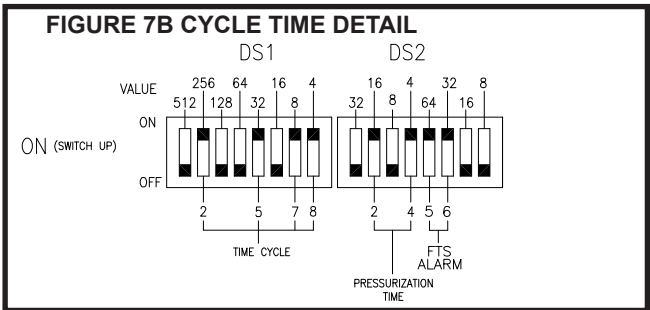
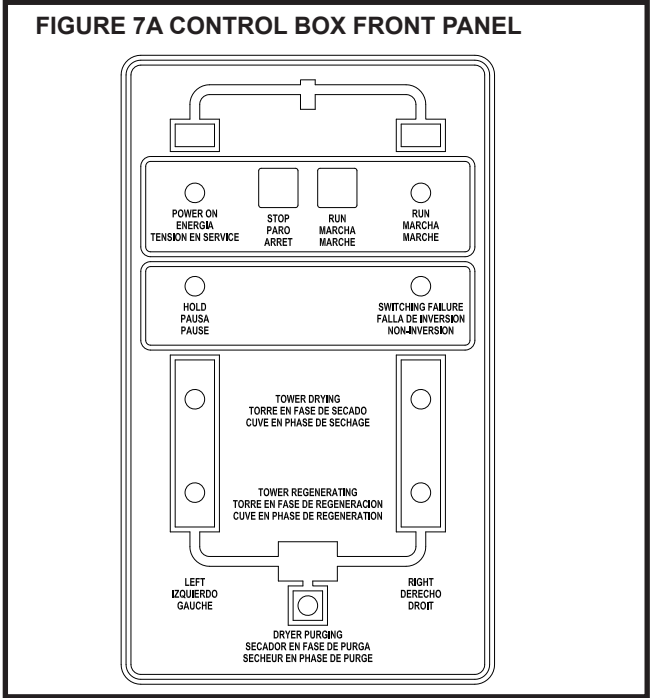

7.2 SETTING THE CYCLE TIME

Reference Figure 7B:

The setting for the time cycle is a **5 min/half cycle**. For the half cycle time setting, the switches indicated for **DS1 (2, 5, 7, & 8)** as shown in the **CYCLE TIME DETAIL** have been factory set by pushing the switches up. The values for these switches are **(256, 32, 8, & 4) sec.**, so when added together equal **300 sec or 5 min. WE DO NOT RECOMMEND** a time cycle setting below **2 min/half cycle**. For this half cycle time setting, the switches that need to be pushed up are **DS1 (4, 5, 6, & 7)** their values are **(64, 32, 16, & 8) sec.** so when added together equal **120 sec or 2 min.**

The setting for the pressurization time is **20 sec.** For the pressurization time setting, the switches indicated for **DS2 (2 & 4)** as shown in the **CYCLE TIME DETAIL** have been factory set by pushing the switches up. The values for these switches are **(16 & 4) sec.**, so when added together equal **20sec. WE DO NOT RECOMMEND CHANGING THIS SETTING.**

The setting for the alarm time is **96 sec.** For the alarm time setting, the switches indicated for **DS2 (5 & 6)** as shown in the **CYCLE TIME DETAIL** have been factory set by pushing the switches up. The values for these switches are **(64 & 32) sec.**, so when added together equal **96 sec. WE DO NOT RECOMMEND CHANGING THIS SETTING.**

NOTE: THE ALARM TIME SETTING NEEDS TO BE LESS THAN THE HALF CYCLE TIME SETTING OR THIS WILL NEGATE THE ALARM FUNCTION.

IMPORTANT

Operating this dryer on the 4 minute cycle will more than double the wear on the dryer components. To reduce wear on the dryer, operate the dryer on the 10 minute cycle if the -40°F dew point is acceptable.

FIGURE 7C TIMING CHART FOR STANDARD CONTROL

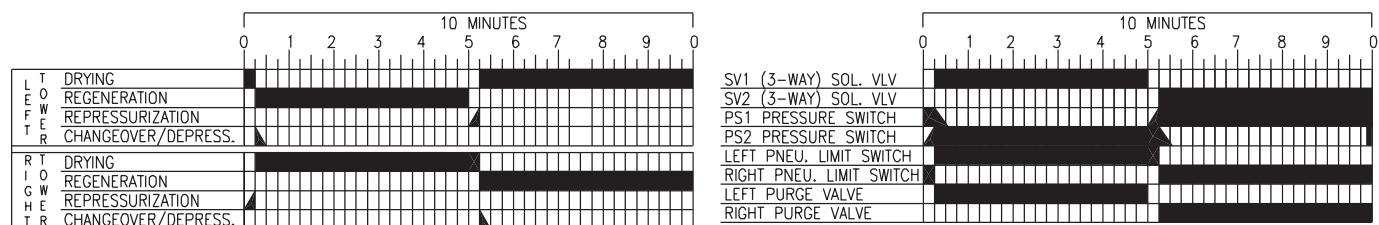

8.1 CYCLE SAVER CONTROL

The CYCLE SAVER control uses a printed circuit board. It is housed in a NEMA 4X fiberglass enclosure. It has the following features:

- POWER ON/OFF SWITCH
- POWER ON LED
- CYCLE MODE PUSHBUTTON
- FIXED MODE LED
- AUTO MODE LED
- ENERGY SAVINGS LED
- SWITCHING FAILURE LED
- RESET PUSHBUTTON
- L/R TOWER DRYING LEDS
- L/R TOWER REGENERATING LEDS

The Dryer Status LEDs are located on the front panel of the control box. Figure 8A shows the location of each. **Note: There are six other LEDs located on the inside of the control box. Reference SECTION 8.5.**

Start the dryer per SECTION 5.1. When the left tower is pressurized and on line drying the process air, the corresponding LEFT TOWER DRYING LED will be lit. When the right tower is pressurized and on line drying process air, the corresponding RIGHT TOWER LED is illuminated. The operation timing sequence of the dryer is shown in Figure 8B TIMING CHART FOR CYCLE SAVER.

8.2 SETTING THE CYCLE MODE

Pressing the Cycle Mode Pushbutton will alternate between the FIXED and AUTO modes. This will light either the Fixed or Auto Mode LED.

8.2-1 OPERATING THE DRYER IN THE FIXED MODE

When operating the dryer in the FIXED MODE, press the Cycle Mode Pushbutton until the Fixed Mode LED is lit. The dryer will not utilize the ENERGY SAVINGS feature.

The fixed cycle is a normal 10 minute cycle. The dryer changes towers every five minutes. The dryer goes through a normal tower changeover sequence (repressurization, tower changeover, depressurization).

The SWITCHING FAILURE ALARM is operational in both the FIXED and AUTO modes.

8.2-2 OPERATING THE DRYER IN AUTO MODE

When operating the dryer in the AUTO MODE, press the Cycle Mode Pushbutton until the Cycle Mode LED is lit.

The dryer will operate in the start up cycle for the first 20 minutes of operation at every start up. After the start up cycle has been completed, the dryer will operate in the mode that the Cycle Mode is set (FIXED or AUTO).

In the Auto Mode, the length of time that a tower is in the drying stage is controlled by the humistat set point adjustment on the printed circuit board.

8.2-2A ENERGY SAVINGS

At the end of a normal regeneration stage, if the tower humistat indicates a good dew point, ENERGY SAVINGS has been activated. If the dew point is not low enough to activate ENERGY SAVINGS, the dryer will switch towers.

When ENERGY SAVINGS is activated, the ENERGY SAVINGS LED is illuminated. The purge exhaust valve on the regenerating tower is closed and that tower comes up to full line pressure. No purge air will be exhausted at this time.

The tower that was in the drying stage will remain on line and drying the process air until the dew point rises to the set point of the humistat.

The maximum time a tower can stay in energy savings is four hours. This is to prevent channeling of the desiccant under very low flow conditions.

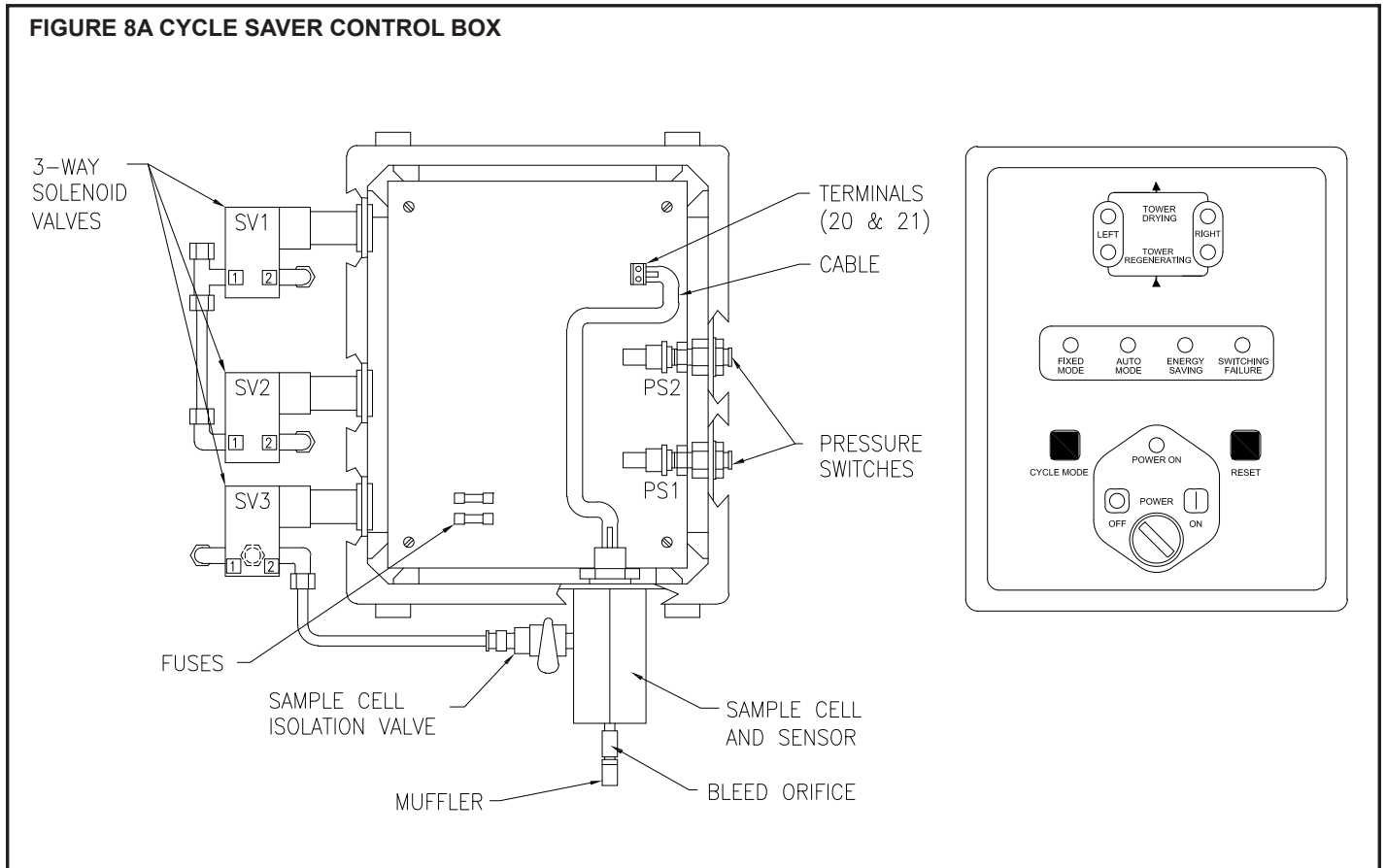

8.3 FAILURE TO SWITCH ALARM

The FAILURE TO SWITCH ALARM is operational in the FIXED and AUTO modes.

The dryer is continuously being monitored for switching failure. Two pressure switches monitor the pressure in the desiccant towers. If pressure is present in the tower that should be in the regenerating stage, the alarm is activated. The printed circuit board gives the dryer 90 seconds to depressurize after tower changeover before the alarm is activated.

If one or both of the pressure switches fail, the alarm is NOT activated, but the dryer is switched into a 10 minute fixed cycle.

When the alarm is activated, the FAILURE TO SWITCH LED is illuminated. The alarm does not stop the dryer from cycling. The FAILURE TO SWITCH ALARM is a latching alarm. Once the problem causing the switching failure is corrected, the FAILURE TO SWITCH RESET PUSHBUTTON must be pressed to reset the alarm. If the alarm is reset and the problem is not corrected, the alarm will be re-activated after 90 seconds.

- The switching failure alarm will activate when:
- The inlet transfer valve does not change positions and does not direct the process flow through the proper tower.
 - The purge exhaust valve does not open on the regenerating tower or if tower pressure in the regenerating tower does not drop below 40 psig.
 - The purge exhaust valve does not close on the regenerating tower to allow repressurization.

The GENERAL ALARM contact is closed when this alarm is activated.

FIGURE 8B TIMING CHART FOR CYCLE SAVER

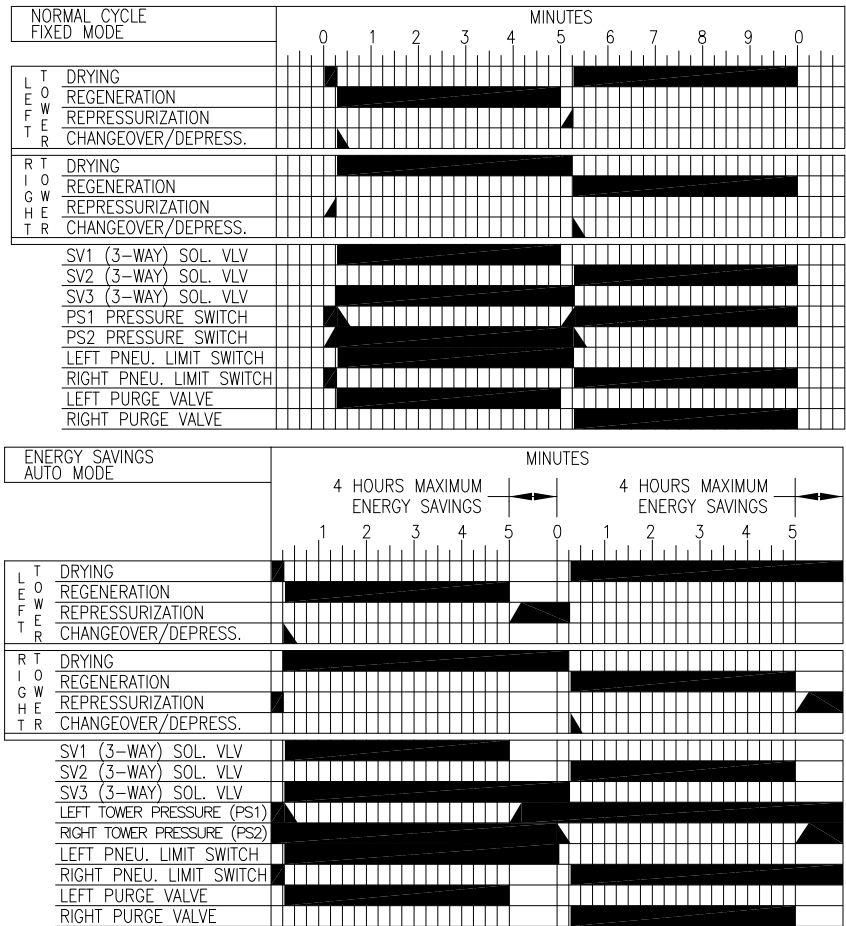

8.4 GENERAL ALARM

The general alarm contact was provided for the customer to wire the dryer's alarm into a main control room, or to a warning light or horn. The contact is a normally open dry contact. The contact is closed if the SWITCHING FAILURE ALARM has been activated. The contact will only reset if the alarm condition is corrected.

8.5 PRINTED CIRCUIT BOARD (LEDs)

The Humidity Indication LED (RED) is on when the humidity is above the set point.

The SV1 Indication LED (GREEN) is on when the valve is energized.

The SV2 Indication LED (GREEN) is on when the valve is energized.

The SV3 Indication LED (GREEN) is on when the valve is energized.

The PS1 Indication LED (GREEN) is on when the switch is closed.

The PS2 Indication LED (GREEN) is on when the switch is closed.

Note: These LEDs are located on the inside of the control box on the printed circuit board. Figure 8C illustrates the LEDs locations.

FIGURE 8C CYCLE SAVER PRINTED CIRCUIT BOARD

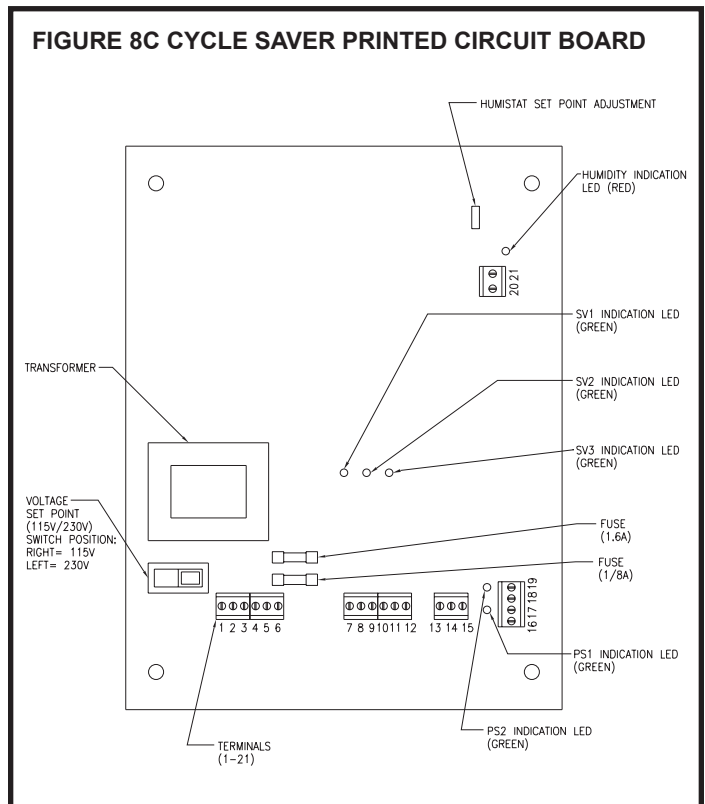

9.1 EMCON II CONTROL

The EMCON II control is programmable logic controller (PLC) based. It is housed in a NEMA 4X fiberglass enclosure.

The EMCON II control has the following features:

- Power ON/OFF Push-button/Light
- Cycle Selector Switch Fixed/Auto
- Energy Saving Activated Light
- Tower Status Lights
 - Left and Right Tower Drying
 - Left and Right Tower Regenerating
- Failure To Switch Alarm Light/Reset Push-button
- High Humidity Alarm Light/Reset Push-button

The Tower Status Lights are used to indicate which tower is on line drying the process air and which tower is regenerating.

The FAILURE TO SWITCH ALARM LIGHT is illuminated when the Failure To Switch Alarm is activated. The light is also a push-button which resets the alarm.

The HIGH HUMIDITY ALARM LIGHT is illuminated when the High Humidity Alarm is activated. The light is also a push-button which resets the alarm.

9.2 SETTING THE CYCLE SELECTOR SWITCH

The Cycle Selector Switch is used to switch the dryer cycle. When the switch is set to the FIXED MODE, the dryer will operate on a 10 minute cycle. When the switch is set to the AUTO MODE, the dryer cycle is controlled by the PLC, the tower dew point controller and the outlet dew point controller.

When the dryer is operated in the AUTO MODE and the dew point controllers allow the dryer to operate in an extended cycle, the ENERGY SAVINGS ACTIVATED LIGHT is activated.

9.2-1 OPERATING THE DRYER IN FIXED MODE

To operate the dryer in the FIXED MODE, set the CYCLE SELECTOR SWITCH to the FIXED position. The dryer will not utilize the ENERGY SAVINGS feature.

The fixed cycle is a normal 10 minute cycle. The dryer changes towers every five minutes. The dryer goes through a normal tower changeover sequence (repressurization, tower changeover, depressurization).

The SWITCHING FAILURE ALARM and the HIGH HUMIDITY ALARM are operational in both the FIXED and AUTO modes.

9.2-2 OPERATING THE DRYER IN AUTO MODE

To operate the dryer in the AUTO MODE, set the CYCLE SELECTOR SWITCH to the AUTO position.

The dryer will operate in the start up cycle for the first 20 minutes of operation at every start up. After the start up cycle is completed, the dryer will operate in the mode that the CYCLE SELECTOR SWITCH is set (FIXED or AUTO).

In the auto mode, the length of time that a tower is in the drying stage is controlled by the microprocessor and both the tower and outlet humistats.

9.2-2A ENERGY SAVINGS

At the end of a normal regeneration stage, if both the outlet and tower humistats indicate good dew points, ENERGY SAVINGS is activated. If the dew points are not low enough to activate

FIGURE 9A EMCON II CONTROL BOX

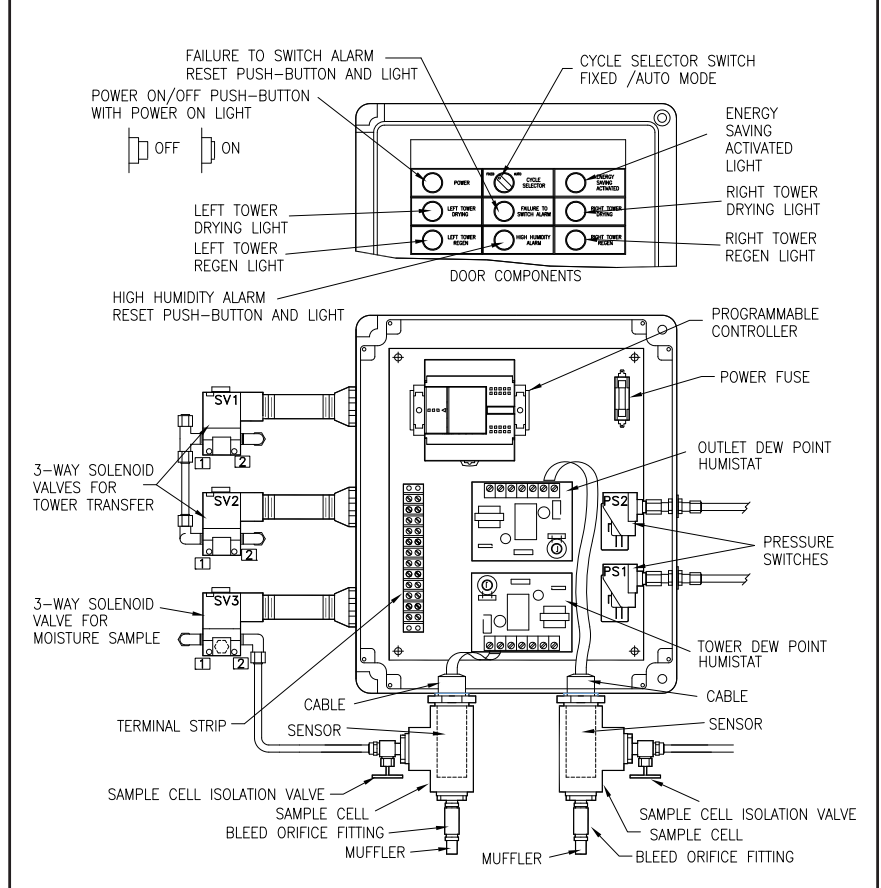

ENERGY SAVINGS, the dryer will switch towers.

When ENERGY SAVINGS is activated, the ENERGY SAVINGS ACTIVATED light will be illuminated. The purge exhaust valve on the regenerating tower is closed and that tower comes up to full line pressure. No purge air will be exhausted at this time.

The tower that was in the drying stage will remain on line and drying the process air until the dew point rises to the set point of either humistat.

The maximum time a tower can stay in energy savings is four hours. This is to prevent channeling of the desiccant under very low flow conditions.

9.2-2B DEW POINT CALIBRATION CYCLE

When the dryer is in the calibration cycle, it will switch towers every 2.5 minutes. By reducing the drying cycle, the inlet moisture load on the towers will be decreased. This will try to push the drying mass transfer zone lower in the desiccant bed.

If the dew point of either tower stays high continuously for five consecutive drying cycles on that tower, the microprocessor will start short cycling the dryer. The dryer will remain in the calibration cycle until the tower dew point meter detects a good dew point in each tower for at least 10 seconds of each drying stage.

If the outlet dew point rises above the set point of the outlet humistat any time after the 20 minute start up cycle, the dryer will be switched into the calibration cycle for a minimum of 20 minutes, even if the outlet dew point returns to a good dew point (below the humistat set point).

If the outlet dew point remains above the humistat set point

continuously for 15 minutes on either tower, the HIGH HUMIDITY ALARM is activated.

The HIGH HUMIDITY ALARM is a latching alarm. Before the alarm can be reset, the dryer must operate for one complete cycle with the outlet dew point below the outlet humistat set point. Then the HIGH HUMIDITY ALARM LIGHT/PUSH-BUTTON can be pressed to clear the alarm condition.

9.3 FAILURE TO SWITCH ALARM

The FAILURE TO SWITCH ALARM is operational in the FIXED and AUTO modes.

Two pressure switches monitor the pressure in the desiccant towers. If pressure is present in the tower that should be in the regenerating stage, the alarm is activated. The microprocessor gives the dryer 90 seconds to depressurize after tower changeover before the alarm is activated.

If one or both of the pressure switches fail, the alarm is NOT activated, but the dryer is switched into a 10 minute fixed cycle.

When the alarm is activated, the FAILURE TO SWITCH LIGHT/Push-button is illuminated. The alarm does not stop the dryer from cycling. The FAILURE TO SWITCH ALARM is a latching alarm. Once the problem causing the switching failure is corrected, the FAILURE TO SWITCH LIGHT/PUSH-BUTTON must be pressed to reset the alarm. If the alarm is reset and the problem is not corrected, the alarm will be re-activated after 90 seconds.

The switching failure alarm will activate when:

- The inlet transfer valve does not change positions and does not direct the process flow through the proper tower.
- The purge exhaust valve does not open on the regenerating tower or if the tower pressure in the regenerating tower does not drop below 30 psig.
- The purge exhaust valve does not close on the regenerating tower to allow repressurization.

The GENERAL ALARM contact is closed when this alarm is activated.

9.4 HIGH HUMIDITY ALARM

The HIGH HUMIDITY ALARM is operational in the FIXED and AUTO modes. The alarm is disabled while the dryer is in the 20 minute start up cycle. When it is activated the dryer will continue to operate.

The HIGH HUMIDITY ALARM is a latching alarm condition. To turn off the light the reset button must be pushed. The GENERAL ALARM contacts are closed when this alarm is activated.

FIXED MODE

After the 20 minute start up cycle, if the outlet dew point remains above the humistat set point continuously for 15 minutes on either tower, the HIGH HUMIDITY ALARM is activated.

FIGURE 9B TIMING CHART FOR EMCON II

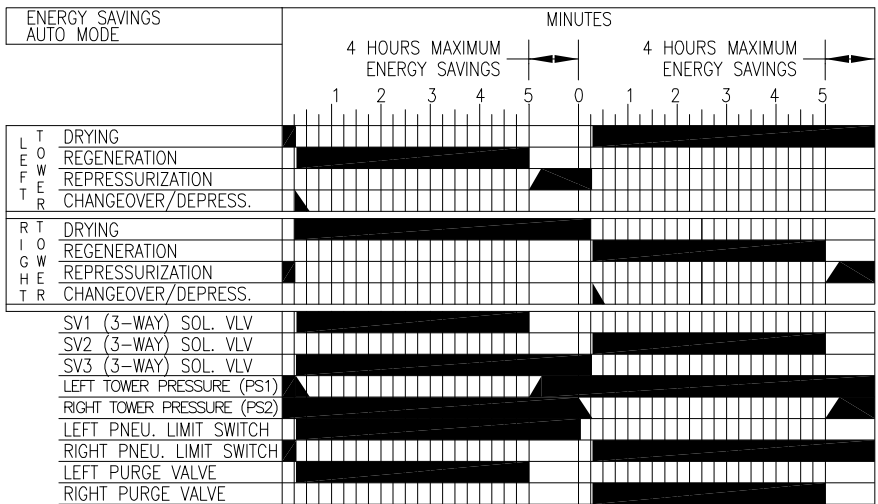
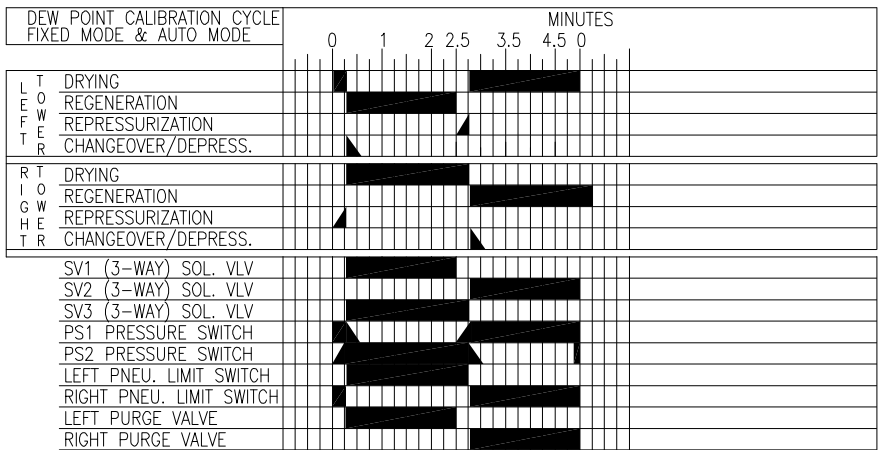
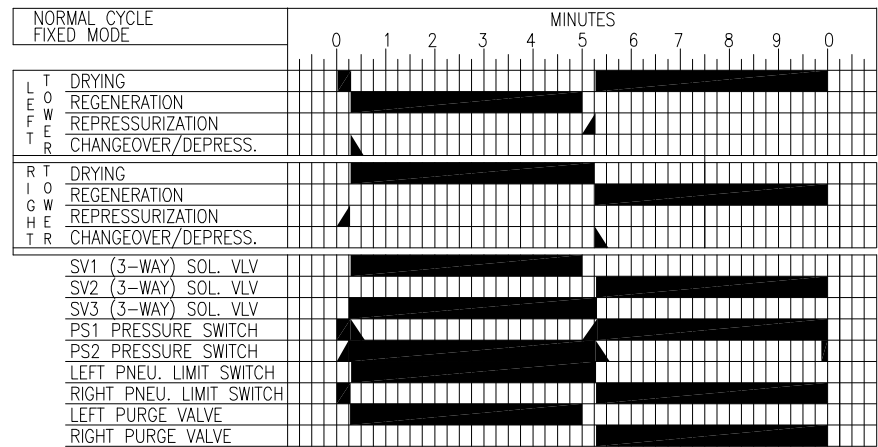

AUTO MODE

If the outlet dew point rises above the set point of the outlet humistat anytime after the 20 minute start up cycle, the dryer will be forced into the calibration cycle for a minimum of 20 minutes. If the outlet dew point remains above the humistat set point continuously for 15 minutes on either tower, the HIGH HUMIDITY ALARM is activated.

9.5 GENERAL ALARM

The general alarm contact was provided for the customer to wire the dryer's alarms into a main control room, or to a warning light or horn. The contact is a normally open dry contact. The contact is closed if either the HIGH HUMIDITY ALARM or the SWITCHING FAILURE ALARM is activated. The contact will only reset if the alarm condition has been corrected. There is an individual reset push-button for each alarm.

10.1 SHUTDOWN PROCEDURES

Close the inlet and outlet isolation valves (if installed). Open the bypass valve (if installed). Let the dryer depressurize completely.

Turn the dryer off by either pressing the Stop button if the dryer has a Standard Control Box or place the Power ON/OFF switch to the OFF

position for the Cycle Saver or Emcon II Control Boxes.

If maintenance is to be performed on the dryer, make sure the dryer is completely depressurized. Tower pressure gauges must read 0 PSIG before removing any item on the dryer.

MAINTENANCE & TROUBLESHOOTING

SECTION 11

11.1 DAILY INSPECTION

The following procedures should be performed daily:

- Check the dryer operating conditions, inlet temperature, ambient temperature, inlet pressure and inlet flow.
- Monitor the dryer for one complete cycle. Make sure it is operating properly.
- Check the purge mufflers. Purge air should be exhausting from one of the valves. If oil is present, the dryer and air system may be contaminated with lubricants.
- Inspect all upstream equipment, aftercoolers, separators, drains and filters.
- Check the pressure differential indicator on all prefilters and afterfilters. If the differential pressure is unacceptable, replace the elements.
- Check the prefilter(s) for proper draining. If the prefilter is not equipped with an automatic drain, it must be drained manually.
- Make sure that all bypass valves are tightly closed.
- Visually check the dryer and piping for damage.
- Visually check the dryer moisture indicator (blue dry or pink wet)

11.2 SCHEDULED MAINTENANCE

12 MONTHS

- Replace purge muffler elements
- Replace the control air filter element

24-60 MONTHS

- The desiccant in the towers should be replaced every two to five years. The life of the desiccant will vary depending on the inlet air conditions. Systems with excessive contaminants and/or inadequate filtration will decrease the life span of the desiccant drastically. Once the desiccant is contaminated with lubricants, it must be replaced.

11.3 DESICCANT REPLACEMENT

WARNING

DO NOT ATTEMPT TO REMOVE PLUGS OR HATCH COVERS UNTIL ALL AIR PRESSURE IS OUT OF THE VESSEL. CHECK ALL TOWER PRESSURE GAUGES, MAKING SURE THAT THEY ARE AT 0 PSIG AND INCOMING PRESSURE HAS BEEN TURNED OFF.

ALWAYS WEAR EYE PROTECTION AND GLOVES WHEN HANDLING THE DESICCANT. DUST FROM THE DESICCANT MAY CAUSE EYE AND SKIN IRRITATION. AVOID BREATHING THE DUST AND PROLONGED CONTACT WITH THE SKIN.

FIRST AID IN CASE OF EYE CONTACT, IMMEDIATELY FLUSH EYES WITH PLENTY OF WATER FOR AT LEAST 15 MINUTES. CONSULT A PHYSICIAN.

Take dryer off stream following the **SHUTDOWN PROCEDURES IN SECTION 10.**

Remove the plugs from the desiccant drain and fill ports; drain old desiccant from each tower.

Remove any oil, dirt, or scale from the towers and inlet piping. Do NOT weld, grind or sandblast the vessels as this voids the ASME Certification. The vessels may be steam cleaned internally and externally to remove dirt and oil.

CAUTION

Make sure that the towers are clean to prevent contamination of new desiccant.

Replace plugs securely on desiccant drain ports. Apply pipe thread sealant as necessary.

Make sure that the drain ports or hatch covers are installed before attempting to fill the towers. Load desiccant through the desiccant filler ports or hatches. **REFER TO SECTION 3.1 FOR PROPER DESICCANT AMOUNTS.**

Reinstall the fill port plugs. Use pipe sealant.

Follow **START UP PROCEDURES IN SECTION 5.1** to start up and place dryer in operation.

11.4 CONTROL AIR FILTER REPLACEMENT

Close the dryer inlet and outlet isolation valves (and open bypass valve if provided). Turn off the power and completely depressurize the dryer.

WARNING

DO NOT REMOVE THE FILTER BOWL FROM HEAD UNTIL HOUSING IS COMPLETELY DEPRESSURIZED.

After all pressure is out of the dryer, grasp the filter bowl firmly, while pushing the bowl upward turn it clockwise to remove it from the filter head.

Remove the used element from the head. Discard used element properly.

Remove new element from the shipping package. Place the new element into the filter head.

While pushing the bowl upward into the head turn the bowl counterclockwise to lock it in place.

Following the start up procedures for the dryer, place the dryer on stream.

11.5 TROUBLESHOOTING

The following check list should be used as a guideline for troubleshooting problems. Each of the topics will reference other sections in this manual for further information.

IS THE POWER ON?

Check the main power source. For dryers equipped with the Standard Control Box make sure the Run button is pressed and the Run LED is lit. For dryers equipped with Cycle Saver or Emcon II Control Boxes make sure the Power ON/OFF switch is in the ON position.

IS THE SYSTEM PRESSURIZED?

The dryer is designed to operate at 60 to 150 psig. Check the upstream equipment and any isolation or bypass valves.

IS THE DRYER CYCLING?

- **IS THE FAILURE TO SWITCH ALARM ACTIVATED?**
If the dryer is not cycling the FAILURE TO SWITCH ALARM should be activated. The dryer should be checked to determine the cause of switching failure.
- **IS THERE CONTROL AIR PRESSURE, 60 PSIG MINIMUM.**
Make sure that the dryer inlet pressure is above 60 PSIG. Check the control air filter element and replace it with a new element. Reference Section 11.4 for element replacement instructions.
- **ARE THE PILOT VALVES FAULTY? (SV1 & SV2)**
Reference Section 11.5-3 for procedures to check the operation of the 3-way valves.
Replace any faulty 3-way valves.
- **IS THE INLET VALVE FAULTY? Reference Section 11.5-5 for procedures to check the operation of the inlet transfer valve.**
Rebuild or replace the inlet valve as necessary. Reference Sections 12.9 & 12.10 for valve breakdowns and repair kit details.
- **IS A PURGE EXHAUST VALVE FAULTY? Reference Section 11.5-7 for procedures to check the operation of the purge exhaust valves.**
Rebuild or replace the faulty purge exhaust valve. Reference Section 12.11 through 12.15 for valve breakdowns and repair kit details.
- **IS AN OUTLET CHECK VALVE FAULTY? Reference Section 11.5-8 for procedures to check the operation of the outlet check valves.**
If a valve is faulty, replace it.
- **IS THE PURGE METERING VALVE SET PROPERLY? Reference Section 5.2 for purge metering valve settings and procedures.**
If the purge metering valve requires adjustment, follow the procedures in Section 5.2.

ARE THE TOWERS DEPRESSURIZING?

- **ARE THE PNEUMATIC LIMIT SWITCHES FAULTY? Reference Section 11.5-6 for procedures to check the operation of the pneumatic limit switches.**
If either of the pneumatic limit switches are faulty, replace them both.

IS THE VISIBLE MOISTURE INDICATOR BLUE? Reference Section 6.2 for an explanation of operation for the moisture indicator.

- **IS THE BLEED ORIFICE FITTING OR SINTERED MUFFLER ON THE MOISTURE INDICATOR CLOGGED?**
Inspect the bleed orifice fitting and the sintered filter on the back of the moisture indicator. They can be cleaned or replaced.

IS THE DEW POINT ACCEPTABLE?

- **ARE THE INLET CONDITIONS WITHIN THE SPECIFICATIONS? Reference Section 3.1 for the inlet conditions of the dryer.**
Correct the inlet conditions if necessary. Excessive inlet flow will greatly reduce the performance of the dryer.

IS THE DEW POINT ACCEPTABLE?

- **IS THE PURGE METERING VALVE SET PROPERLY? Reference Section 5.2 for purge metering valve settings and procedures.**
If the purge metering valve requires adjustment, follow the procedures in Section 5.2.
- **WAS THE DESICCANT INSTALLED?**
Make sure that the desiccant was installed. Reference Section 11.3 for desiccant replacement procedures.
- **IS THE DESICCANT CONTAMINATED WITH LUBRICANTS?**
Check the condition of the desiccant bed. If the bed is contaminated with lubricants, replace the desiccant following the procedures in Section 11.3.
- **IS THE DESICCANT CONTAMINATED WITH MOISTURE?**
If the dryer was operated under excessive inlet conditions, the desiccant bed may be saturated with liquid moisture. Check upstream equipment such as aftercoolers. Check the actual inlet conditions, correct them and condition the bed following the procedures in Section 5.3.
- **ARE THE BYPASS VALVES OPEN OR LEAKING?**
Check the valves (if installed). Repair or replace if faulty.

IS THE ENERGY SAVINGS BEING ACTIVATED? (CYCLE SAVER AND EMCON II MODELS ONLY)

- **IS THE CYCLE SELECTOR SWITCH SET IN THE "AUTO" MODE?**
The Cycle Selector must be set in the "AUTO" mode in order for the dryer to activate the energy savings feature.
- **IS THE DRYER BEING OPERATED AT THE MAXIMUM OPERATING CONDITIONS? Reference Section 3.1 for rated inlet conditions.**
Little or no energy savings will occur if the dryer is being operated at the maximum operating conditions.
- **IS THE SOLENOID VALVE SV3 FAULTY? Reference Section 11.5-4 for procedures to check the operation of SV3.**
If the valve SV3 is faulty replace it.
- **ARE THE TOWER HUMISTAT AND SENSOR WORKING PROPERLY?**
Reference Section 11.5-9 for procedures to check the operation of the sensor and humistat.

Check the sample cell isolation valve and the bleed orifice fitting. If necessary, replace the bleed orifice fitting and/or the bleed muffler.
- **IS THE SAMPLE LINE DAMAGED OR PLUGGED?**
Check the sample line following the procedures in Section 11.5-10. Repair or replace the components as necessary.

11.5-2 CHECKING THE PROGRAMMABLE CONTROLLER EMCON II MODELS ONLY:

The control system consists of three different control systems:

1. The programmable controller (PLC)
2. Input devices (24 volts DC components)
 - a. Pressure switches
 - b. Humistat(s)
 - c. Reset push-button(s)
 - d. Low voltage side of the Power ON/OFF Pushbutton
 - e. Cycle selector switch
3. Output components
 - a. Pilot valve(s)
 - b. Light(s)
 - c. General alarm contact

The PLC controls the cycling of the dryer. The program logic is stored on an electrically erasable EEPROM. Loss of power to the PLC will not cause loss of the logic program.

WARNING
THE POWER ON/OFF PUSH-BUTTON ON THE CONTROL BOX DOES NOT TURN THE POWER OFF TO THE PLC.

The PLC is wired so it is energized when power is supplied to the control box, even if the power on/off push-button is in the off position. This is to prevent loss of retentive counter memory. The counters are used to monitor run time and cycle life of components. The retentive memory will hold the data safely for at least 30 days. The information stored in memory is accessible with a HMI Kit (not supplied).

11.5-2A (Optional) HMI KIT

EMCON II MODELS ONLY:

A Human Machine Interface is available for this dryer. The monitor can be fastened to the PLC. It will allow the operator to view the counters and registers in the program on the PLC.

With the purchase of this HMI kit, a list of the counters and registers will be included. With the list and monitor, the operator can find out the following information:

- How long the dryer has been in operation.
- How many times the valves have been activated.
- How many times the HIGH HUMIDITY ALARM has been activated.
- How many times the FAILURE TO SWITCH ALARM has been activated.
- How long the dryer has operated in ENERGY SAVINGS.
- How long the dryer has operated in the CALIBRATION CYCLE.

The PLC has power, run and error LEDs. If there is power to the PLC, the power LED will be illuminated. If the power LED is not illuminated, check the power supply to the PLC. If there is power present, the PLC is faulty.

If the error LED is lighted, an error has occurred in the program logic. Consult factory.

The run LED must be on for the PLC to operate. If the run LED is off, turn the main power to the dryer off and on again. The PLC should reset and the run LED should turn on. If the LED does not turn on, consult factory.

If the power and run LEDs are on and the error LED off, the PLC may still be faulty. To verify that the input and output of the PLC are operating properly, the input and output devices must be checked. Figure 11B lists the inputs and outputs on the PLC and the corresponding devices.

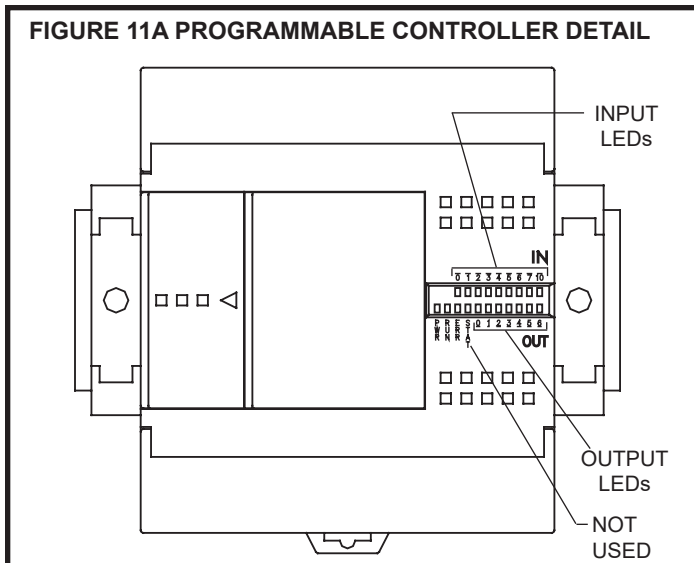

Reference Sections 11.5-2B and 11.5-2C for procedures to verify that the input and output devices are operating properly. If the devices are operating properly, the PLC will need to be replaced.

11.5-2B TESTING THE INPUT DEVICE

EMCON II MODELS ONLY:

The PLC supplies a 24 volt DC signal to the input devices and alarm contacts. If the input device is activated, it will cause that input LED to light. The input LEDs are labeled 0 to 7.

The input devices can be easily tested for proper operation. With power to the control box, set the Power ON/OFF Push-button (PB1) to the OFF position, then the ON position. This should cause LED 0 to light. Pushing the failure to switch light (PB2) should cause LED 3 to light. Pushing the high humidity light (PB3) should cause LED 5 to light. The fixed/auto selector switch can be tested as follows. In the fixed mode, LED 6 should be off. In the auto mode, LED 6 should be lighted. If these input devices do not function as described, they should be replaced.

The pressure switches monitor the failure to switch option. The inputs from the pressure switches (PS1, PS2) can be observed while the dryer is in operation. Any time there is more than 30 psig pressure in the left tower, pressure switch (PS1) should cause LED 1 to light. Any time there is more than 30 psig pressure in the right tower, pressure switch (PS2) should cause LED 2 to light. If the pressure switches do not respond as previously explained, replace them.

To check input 4 or 7, follow the procedures in Section 11.5-9 for calibrating the outlet humistat.

If the input devices are activated and LED is not illuminated, take a voltage measurement across the input terminals. If the device is faulty, it must be replaced. If the device is working properly, check the wiring from the PLC. If the wiring and device are good, the PLC is faulty and should be replaced. Reference Figure 11I DRYER WIRING DIAGRAM for wiring and terminal numbers.

FIGURE 11B INPUT AND OUTPUT LIST (EMCON II)

INPUT	DEVICES	OUTPUT	DEVICES
0	PB1	0	SV1 & PL7
1	PS1	1	SV2 & PL8
2	PS2	2	SV3 & CR1
3	PB2	3	PL2 & CR2
4	CDP1	4	PL3 & CR3
5	PB3	5	PL4
6	SW1	6	SPARE
7	CDP2		
10	SPARE		

NOTE:

The general alarm contact is a normally open dry contact which is wired to terminals #5 and #6.

The lights are run off 120 volts AC which is reduced to 24 volts DC through resistors and diodes on the printed circuit board.

The control relays (CR1, CR2, CR3) are mounted on the board which is mounted to the back of the control box door. CR2 and CR3 are the control relays which give you the general alarm contact.

11.5-2C TESTING THE OUTPUT DEVICES

EMCON II MODELS ONLY:

The microprocessor's outputs are 120 volts AC. The output LEDs are labeled 0 to 5. If the output's LED is illuminated, that output is supplying 120 volts AC to its component.

To check outputs 0 through 2, follow the procedures in Section 11.5-3.

There is no easy way to check outputs 3 through 5. Output 3 can be checked by causing a switching failure. Output 4 can be checked by creating a false outlet dew point by setting the outlet dew point humistat lower than the factory setting and allowing the dryer to go into HIGH HUMIDITY ALARM. Output 5 can be checked when either output 3 or 4 are checked. **Before attempting this procedure, consult the factory.**

11.5-3 CHECKING THE 3-WAY PILOT VALVES (SV1 & SV2) TOWER CHANGEOVER

All 3-way pilot valves have manual override buttons on the top of the valve. To test SV1 and SV2 do the following:

For dryers with the Standard Control Box make sure the Stop button is pressed and the dryer is pressurized. For dryers with Cycle Saver or Emcon II Control Boxes make sure the Power ON/OFF switch is in the OFF position and the dryer is pressurized. Both towers should be at full line pressure pushing the manual override of SV1 should cause the left tower to depressurize. Allow the left tower to come back up to full line pressure. Pushing the manual override of SV2 should cause the right tower to depressurize. If this does not happen, replace that solenoid valve.

EMCON II MODELS ONLY:

With the Power ON/OFF push-button (PB1) in the on position, the fixed/auto selector switch in the fixed mode, and the dryer pressurized, monitor the outputs on the microprocessor. If output 0 is lighted, SV1 should be activated, the left tower should be depressurized and the right tower should be pressurized and drying the compressed air. If output 1 is lighted, SV2 should be activated, the right tower should be depressurized and the left tower should be pressurized and drying your compressed air. These two operations can be monitored in one 10 minute fixed cycle.

If the above responses are not observed, first check to see if power is being supplied to each solenoid valve when the corresponding output LED on the PLC is lighted. Check the wiring between the PLC and solenoid valves. If the PLC is not supplying power to the valve when the LED is illuminated, replace the PLC. If the valve has power but does not operate, it must be replaced.

11.5-4 CHECKING THE SOLENOID VALVE (SV3) TOWER SAMPLE SELECT

CYCLE SAVER AND EMCON II MODELS ONLY:

Solenoid valve (SV3) is used to switch the sample line to the tower that is on line drying your compressed air. It then feeds a sample of air to the tower dew point humistat's sample cell.

With the dryer pressurized, the Power ON/OFF push-button in the ON position, and the dryer in the fixed mode, remove the bleed orifice from the tower dew point humistat's sample cell. Monitor the air flow from the sample cell for one complete 10 minute cycle. There should be full line pressure coming from that sample cell for the whole cycle. If air pressure to the sample cell is lost at any part of the cycle, check the sample line filters and the solenoid valve (SV3). Repair or replace as necessary.

11.5-5 CHECKING THE INLET TRANSFER VALVE

The inlet transfer valve will not switch positions unless the pressure in both desiccant towers is nearly equal. At tower changeover, the regenerating tower should approach full line pressure before the inlet valve will switch. Make sure that there are no leaks in the piping or fittings. Make sure that the purge exhaust valves are closing and that the purge metering valve is properly set.

The exhaust ports on top of the pilot valves (SV1 & SV2) should not have air exhausting through them continuously. If air is exhausting continuously through either of the exhaust ports, the inlet transfer valve is faulty and should be rebuilt or replaced.

To test the inlet transfer valve for proper operation, turn off the power, isolate and depressurize the dryer.

Remove the two pilot lines to the inlet valve. The pilot lines are connected to the outside flanges of the valve. Using an air nozzle and clean air, pressurize one of the ports. Observe the position indicator. It should move in the direction of the port that is being pressurized. No air should be exhausting from the other port.

Pressurize the other port. The valve should move to the other side. If the valve does not move or air is being exhausted out of the port that is not pressurized, the inlet transfer valve must be rebuilt or replaced. Reference Section 12.9 & 12.10 for valve breakdown and parts listing.

11.5-6 CHECKING THE PNEUMATIC LIMIT SWITCHES

Mounted on the inlet transfer valve is a set of 3-way pneumatic limit switches. These switches control the pilot air to open and close the purge exhaust valves.

When a pneumatic limit switch is activated by the inlet transfer valve position indicator, pilot air is supplied to the purge exhaust valve on that side of the dryer.

To check the pneumatic limit switches, allow the dryer to cycle. Check the pilot line to the purge exhaust valve on the side of the activated limit switch. If no air is present, the limit switch must be replaced. The limit switches are sold in sets only.

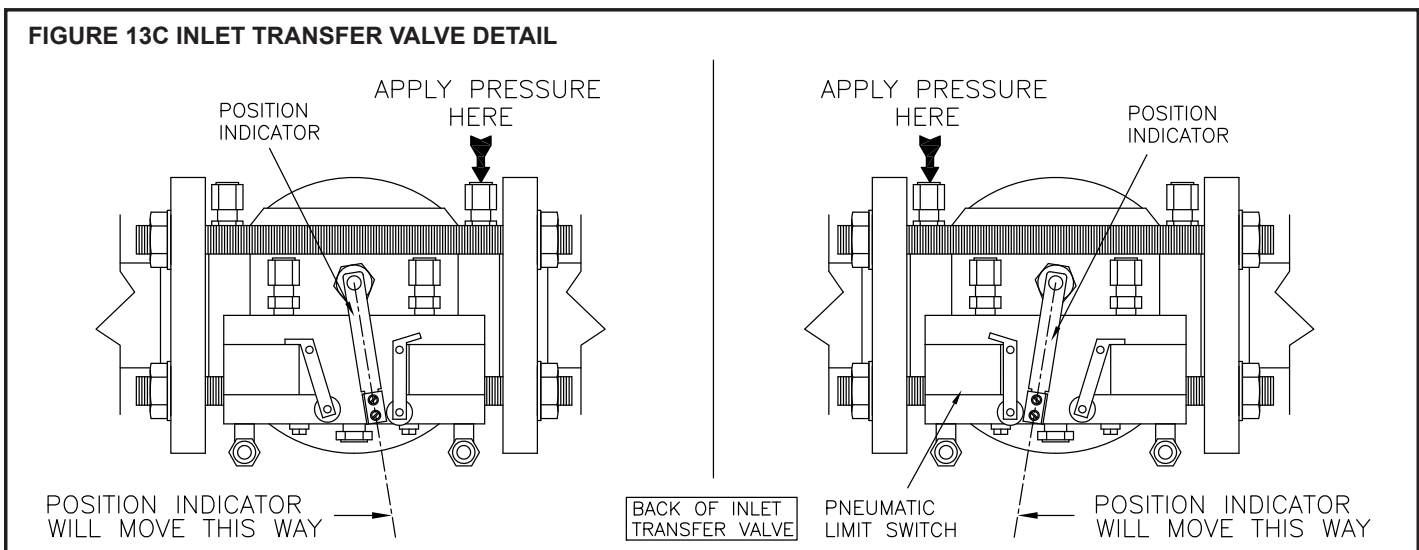

11.5-7 CHECKING THE PURGE EXHAUST VALVES

The purge exhaust valves are normally closed. They can be checked by removing the pilot air lines to them. The valves should be closed.

Using an air nozzle and clean air, pressurize the purge exhaust valves. The valves should open when pressurized. If valve does not open and close, it should be rebuilt or replaced. See Section 12.11 through 12.15 for valve breakdown and parts listing.

11.5-8 CHECKING THE OUTLET CHECK VALVES

This dryer uses two check valves for outlet air control. If either of the outlet valves fails, one of the following will occur:

- A large amount of air will purge from one tower
- The outlet air flow will be blocked

If either happens, the faulty check valve must be replaced.

11.5-9 CALIBRATING THE HUMISTAT

CYCLE SAVER AND EMCON II MODELS ONLY:

The set point for the humistat is calibrated by a set plug.

Unplug the cable from the sample cell. Plug the set plug into the end of the humistat cable.

For dryers equipped with the Cycle Saver Control Box turn the humistat set point adjustment located on the printed circuit board until the Humidity Indication LED is lit. This will calibrate the dew point meter. **Reference Figure 11E.**

For dryers equipped with the Emcon II Control Box turn the potentiometer on the humistat board until you see the LED input light turn on. This will calibrate the dew point meter. **Reference Figure 11D.**

If you get no response from the humistat set point adjustment or the potentiometer with the set plug in, first check the cable connection. If the cable and set plug are good, replace the printed circuit board (Cycle Saver) or the humistat board (Emcon II).

The sensor can be tested by removing it from the sample cell and plugging it into the cable. With the sensor in the ambient air, the humistat should turn on the corresponding LED. Place the sensor back into the sample cell and allow compressed air to pass over it. The LED for the humistat should turn off in several minutes if the air is dry. If you get no response from the LED, replace the dew point sensor.

CAUTION

NEVER USE AN OHMMETER TO CHECK THE SENSOR. THE USE OF AN OHMMETER OR ANY ELECTRICAL TESTING DEVICE WILL CAUSE DAMAGE TO THE SENSOR.

11.5-10 SAMPLE LINE MAINTENANCE

WARNING

DO NOT ATTEMPT TO REMOVE ANY FITTINGS UNTIL ALL AIR PRESSURE IS OUT OF THE VESSEL. CHECK ALL TOWER PRESSURE GAUGES, MAKING SURE THAT THEY ARE AT 0 PSIG AND THE DRYER IS ISOLATED.

Take dryer off stream following the **SHUTDOWN PROCEDURES IN SECTION 10.**

Disconnect the sample line at the tee fitting.

Unthread the sample line from the tower at the bushing. Carefully pull the sample line assembly from the tower. Some desiccant will drain from the tower. Plug the coupling to prevent more desiccant from draining.

Unthread the sample line filter from the tubing. Clean or replace the filter. The filter is made of sintered bronze material. To clean it, use pressurized, clean air.

Re-install the filter. Carefully push the assembly back into the tower and tighten the bushing into the coupling. **DO NOT FORCE THE ASSEMBLY.** An application of pipe sealant to the bushing threads may be necessary. Reconnect the line at the tee fitting.

FIGURE 11D HUMISTAT DETAIL FOR EMCON II

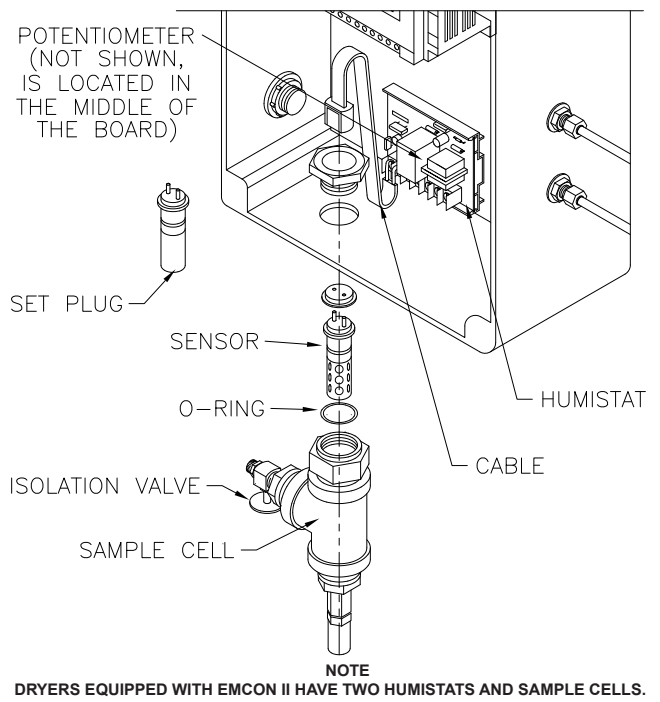

FIGURE 11E HUMISTAT DETAIL FOR CYCLE SAVER

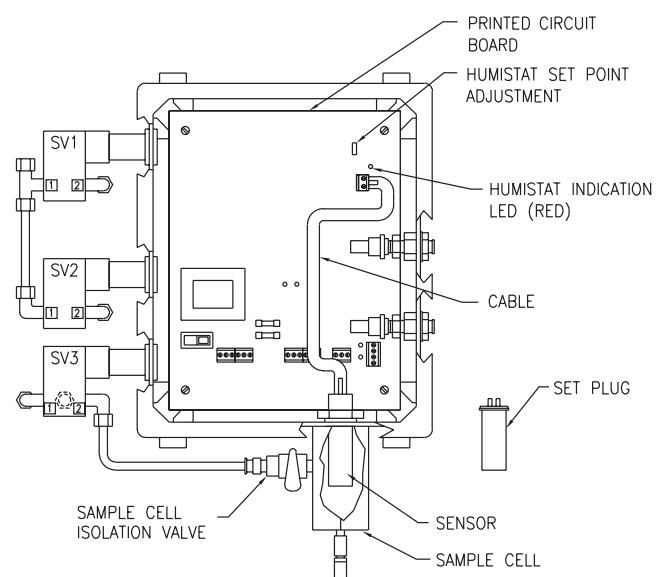
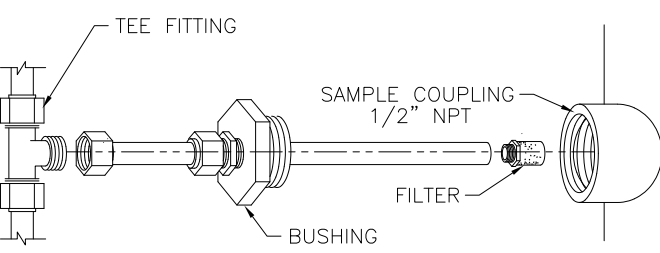

FIGURE 11F SAMPLE LINE DETAIL



11.6 WIRING DIAGRAMS

FIGURE 11G WIRING DIAGRAM for STANDARD CONTROL

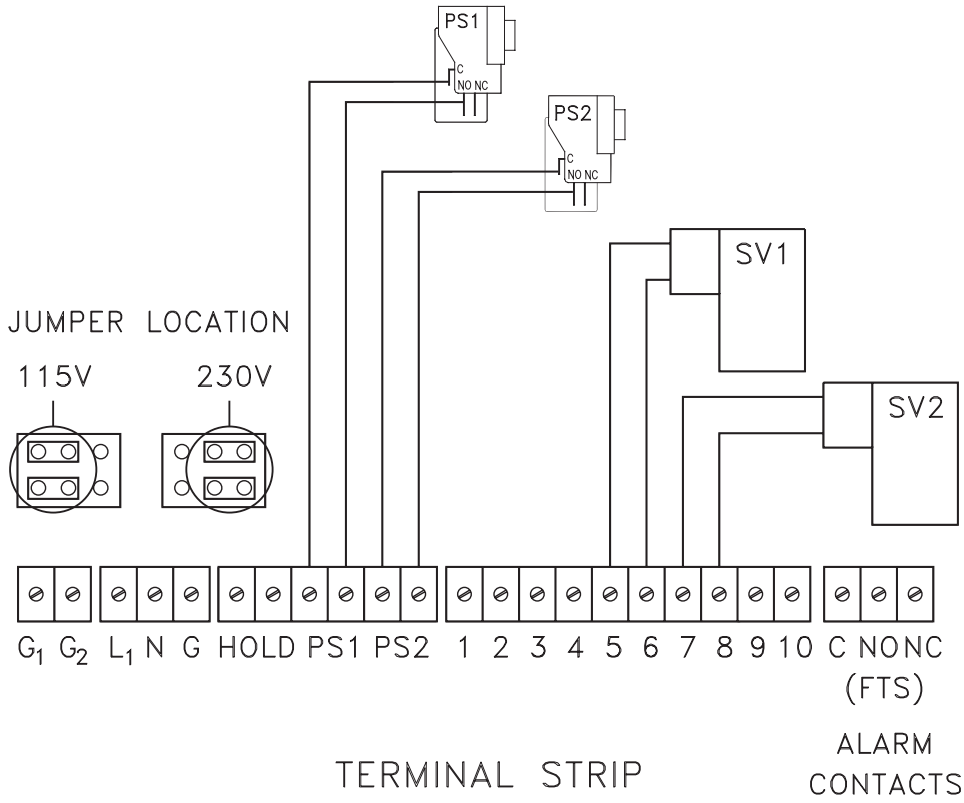

FIGURE 11H WIRING DIAGRAM for CYCLE SAVER

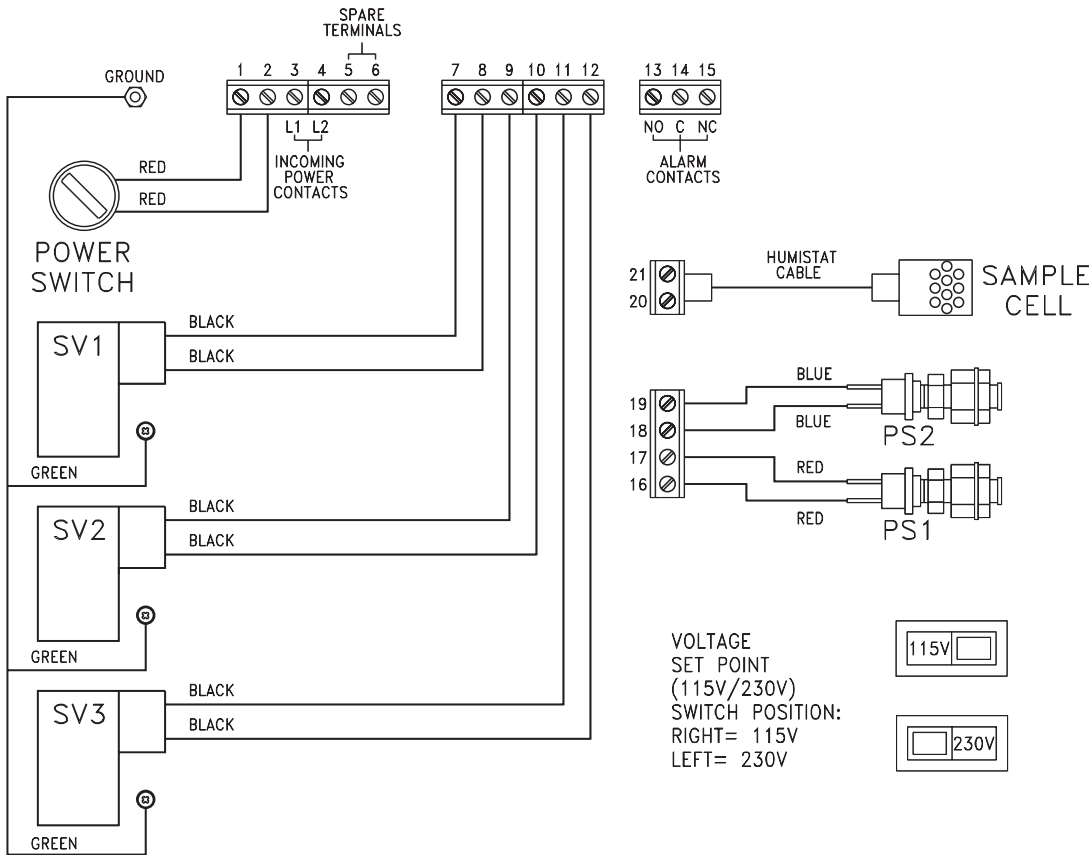

FIGURE 11I WIRING DIAGRAM for EMCON II

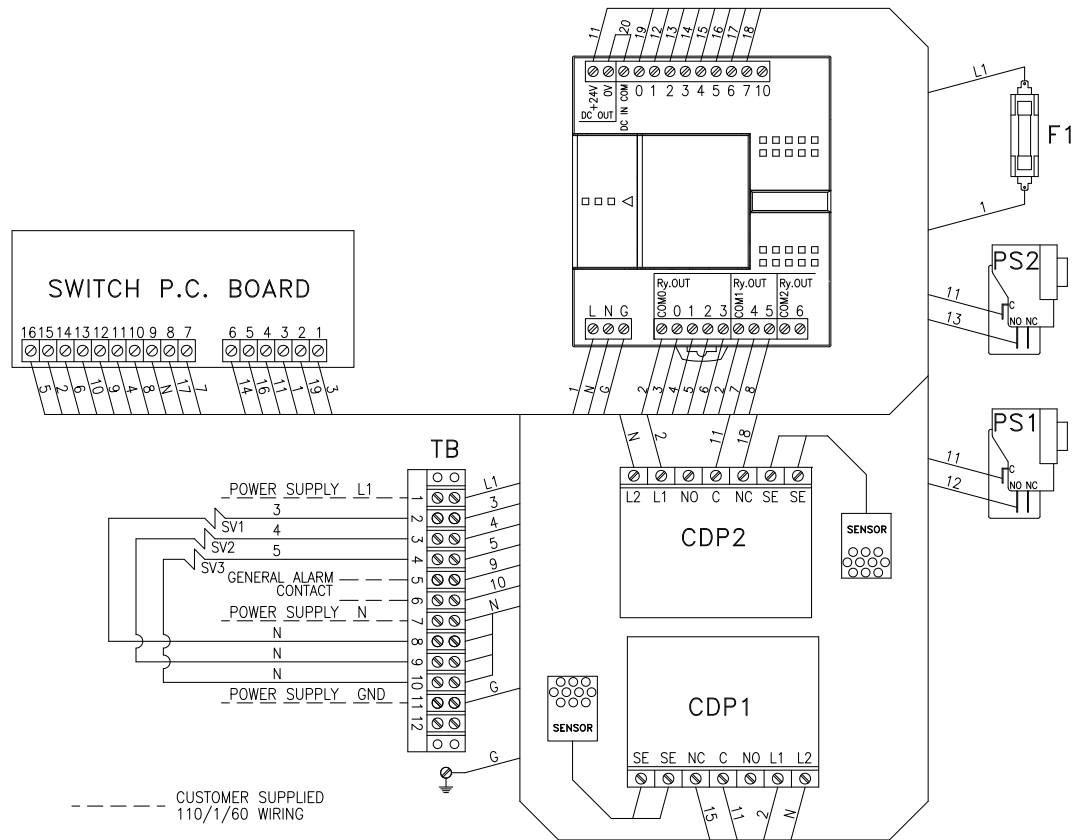
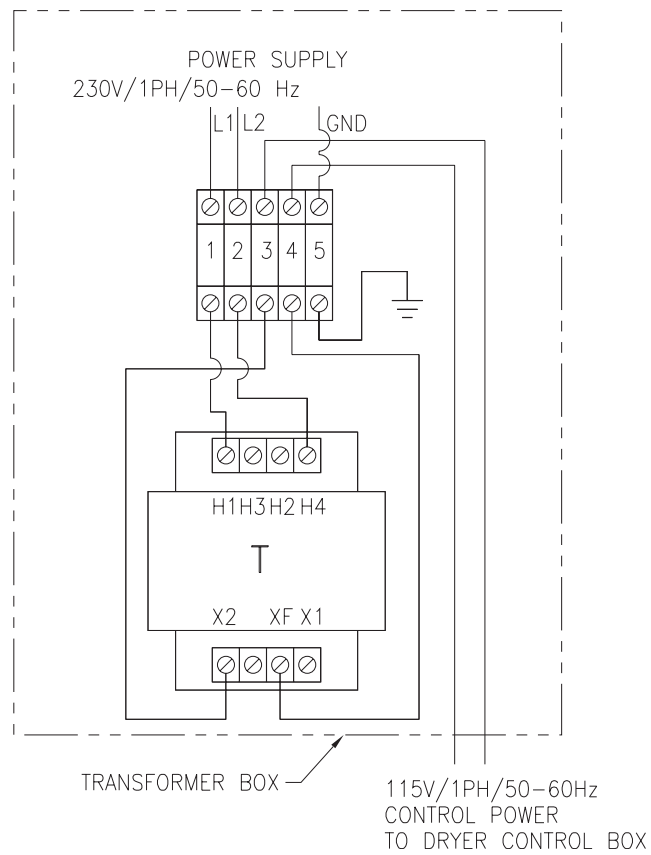
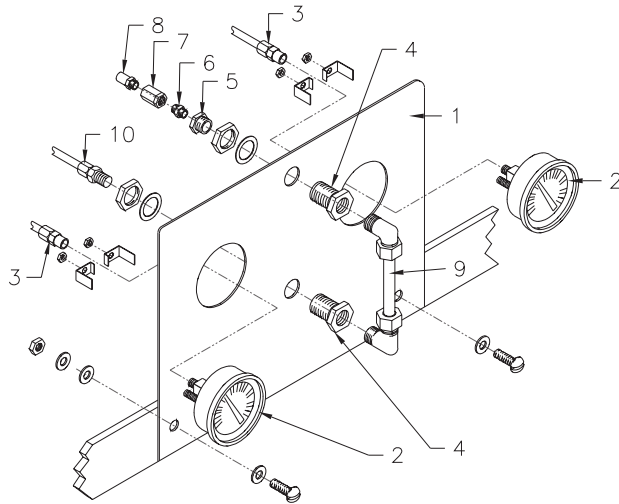

FIGURE 11J WIRING DIAGRAM for OPTIONAL 230 VOLT TRANSFORMER BOX



12.1 STANDARD CONTROL AND CYCLE SAVER GAUGE PANEL REPLACEMENT PARTS

ITEM	QTY	DESCRIPTION	STANDARD CONTROL PART NO.	CYCLE SAVER PART NO.
1	1	Panel	26-6487	26-5654
2	2	2" Pressure Gauge, 0-200 PSIG	29-0278	29-0278
3	2	1/8" NPT x 1/4" Female Straight Tube Fitting	26-0233	26-0233
4	2	1/4" NPT Anchor Tube Fitting	26-1497	26-1497
5	1	1/4" NPT x 10-32 Reducer Bushing	26-0296	26-0296
6	1	10-32 Short Coupling	26-0657	26-0657
7	1	10-32 Choke Fitting	26-0490	26-0490
8	1	10-32 Sintered Filter	26-0623	26-0623
9	1	Visible Moisture Indicator Assembly	46-2300	46-2300
10	1	1/4" NPT x 1/4" Male Straight Tube Fitting	26-0231	26-0231



12.2 EMCON II GAUGE PANEL REPLACEMENT PARTS

ITEM	QTY	DESCRIPTION	PART NO.
1	1	Panel	26-5655
2	4	2" Pressure Gauge, 0-200 PSIG	29-0278
3	4	1/8" NPT x 1/4" Female Straight Tube Fitting	26-0233
4	2	1/4" NPT Anchor Tube Fitting	26-1497
5	1	1/4" NPT x 1/4" Male Straight Tube Fitting	26-0231
6	1	Visible Moisture Indicator Assembly	46-2300
7	1	10-32 Choke Fitting	26-0490
8	1	10-32 Short Coupling	26-0657
9	1	1/4" NPT x 10-32 Reducer Bushing	26-0296
10	1	10-32 Sintered Filter	26-0623

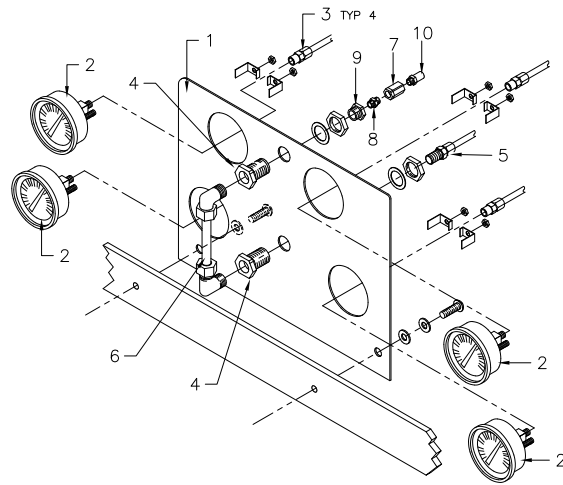

12.3 STANDARD CONTROL SYSTEM REPLACEMENT PARTS

ITEM	QTY	DESCRIPTION	115V	230V
			PART NO.	PART NO.
1	1	Enclosure	27-1139	27-1139
2	1	Panel Membrane and Ribbon Connector	26-6356	26-6356
3	1	Circuit Board	26-6469	26-6469
4	2	Pressure Switch	26-5284	26-5284
5	2	Female Connector Fitting	26-6492	26-6492
6	2	Threaded Seal Fitting	26-3042	26-3042
7	2	1/2" NPT x 2" LG Close Nipple, Galvanized	12-0515	12-0515
8	2	Seal Fitting	26-0883	26-0883
9	2	1/8" Solenoid Valve	14-2082	14-2083
10	3	Male Elbow Tube Fitting	26-0234	26-0234
11	1	Male Tee Tube Fitting	26-0504	26-0504
12	1/4 ft.	Nylon Tubing 1/4" Outside Diameter	26-0223	26-0223
13	2	1/2" Connector Locknut	26-6491	26-6491
14	1	8-32 Washer Stat-O-Seal	28-1371	28-1371
15	1	8-32UNF x 1" LG Rd Mach Grounding Screw	28-1372	28-1372
16	1	8-32UNF Hex Nut	28-1373	28-1373

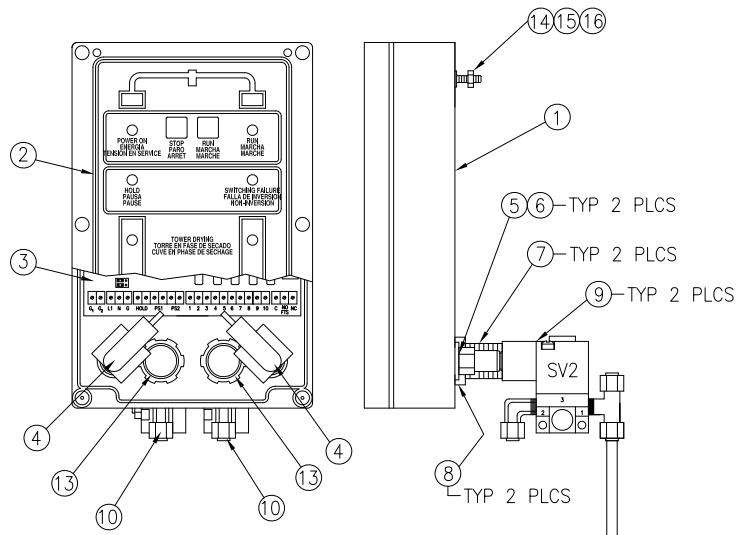

12.4 CYCLE SAVER CONTROL REPLACEMENT PARTS

ITEM	DESCRIPTION	CYCLE SAVER	
		PART NO.	QTY
1	Enclosure	27-1141	1
2	Label (Cycle Saver)	30-1391	1
3	1/8" NPT Solenoid Valve	14-1721	3
4	Male Connector Fitting	26-0639	1
5	Male Tee Tube Fitting	26-0504	1
6	Male Elbow Tube Fitting	26-0234	5
7	Nylon Tubing 1/4" Outside Diameter	26-0223	1/2 ft.
8	PC Mother Board	26-6501	1
9	PC Display Board	26-6502	1
10	Sample Cell Manifold	26-6503	1
11	Sensor	26-0817	1
12	Cable	26-6505	1
13	Pressure Switch	26-6471	2
14	Bulkhead Fitting	26-6472	2
15	Switch (On/Off)	26-6507	1
16	Male Connector Fitting	26-2142	1
17	Dew Point Isolation Valve	14-2110	1
18	10-32 Choke Fitting	26-0490	1
19	10-32 Short Coupling	26-0657	1
20	1/4" x 10-32 Reducer Fitting	26-0296	1

ITEM	DESCRIPTION	CYCLE SAVER	
		PART NO.	QTY
21	10-32 Sintered Filter	26-0623	1
22	1/2" x 2" LG, Conduit Nipple	12-1876	3
23	Seal Nut	26-6512	3
24	Sensor Pin Insert	26-6504	1
25	Washer	26-6508	1
26	Ground Lock Nut	26-6511	3
27	Washer (Phoenix)	26-6525	1
28	Fuse 1- 6/10 Amp	26-6527	1
29	Fuse 1/8 Amp	26-6528	1

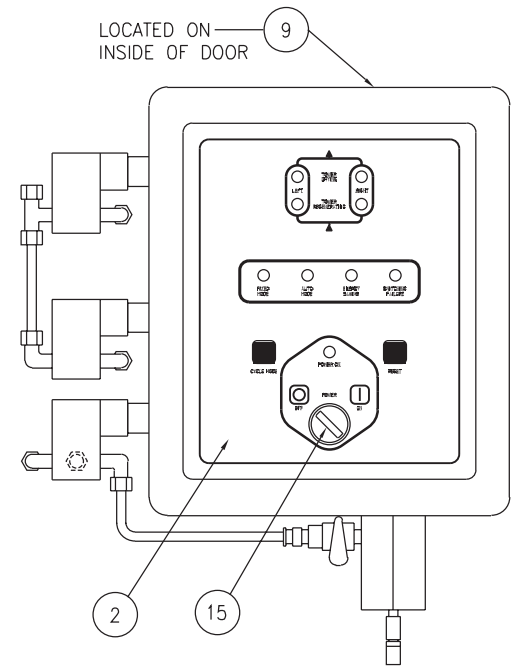
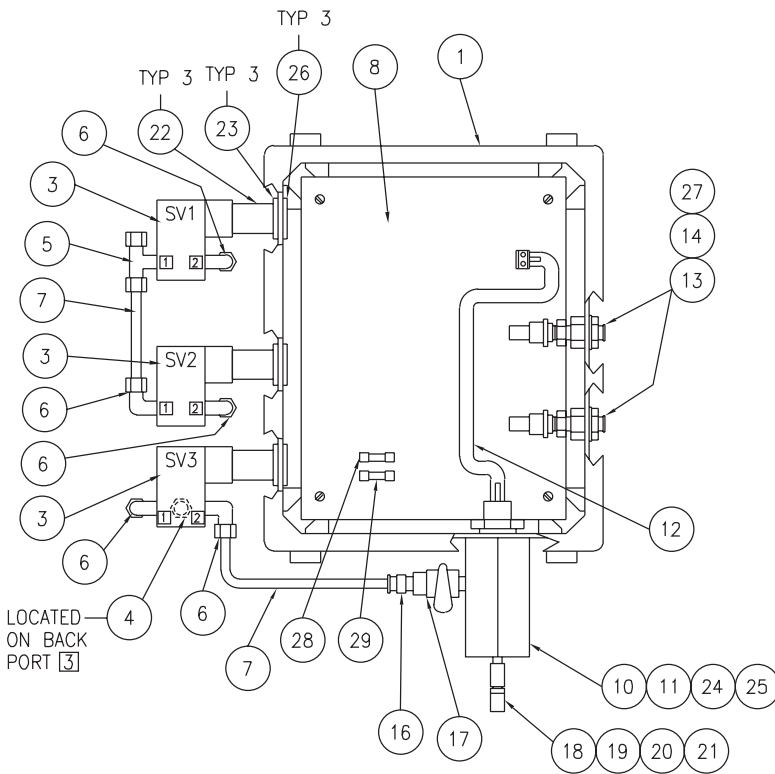

12.5 EMCON II CONTROL REPLACEMENT PARTS

		EMCON II	
ITEM	DESCRIPTION	PART NO.	QTY
1	Fiberglass Enclosure	27-1081	1
2	Back Panel	27-1082	1
3	Programmable controller (programmed)	46-3296	1
4	Pressure Switch	26-5284	2
5	Bulkhead Female Tube Fitting	26-3127	2
6	Thread Seal	26-3042	2
7	Lighted Push-button (white)	26-5621	1
8	Lighted Push-button (red)	26-5622	2
9	Terminal Block	26-5623	1
10	Fuse Block	26-5624	1
11	Fuse 2 amp	26-5625	1
12	Box Label	30-1320	1
13	Humistat	26-0814	2
14	Sensor	26-0817	2
15	Set Plug	26-0818	1
16	Cable	46-2185	2
17	Threaded Mount For Sensor	26-0816	2
18	1" NPT Tee, Galvanized	14-1807	2
19	10-32 Choke Fitting	26-0490	2
20	10-32 Short Coupling	26-0657	2
21	1/4" x 10-32 Reducer Bushing	26-0296	2
22	1" NPT x 1/4" NPT Hex Bushing	14-1808	4
23	Needle Valve 1/4" Tube Fitting	14-1306	2

		EMCON II	
ITEM	DESCRIPTION	PART NO.	QTY
24	1/4" Nut And Sleeve Tube Fitting	26-3043	2
25	10-32 Sintered Filter	26-0623	4
26	Light (green)	26-5628	1
27	Light (yellow)	26-5632	4
28	Switch	26-5629	1
29	Door Component Circuit Board	26-5633	1
30	1/2" Conduit Hub Connector	26-3662	3
31	1/2" NPT Close Nipple	12-1668	3
32	3-Way Solenoid Valve	14-1721	3
33	1/8" NPT x 1/4" Male Elbow Tube Fitting	26-0234	5
34	1/8" NPT x 1/4" Male Straight Tube Fitting	26-0369	1
35	1/8" NPT x 1/4" Male Branch Tee Tube Fitting	26-0504	1
36	Snap Track Mounting Strip	26-5664	2
37	Terminal Strip Marker	26-5762	1
38	1/2" NPT x 1/4" NPT Bushing	14-0441	2
39	1/4" NPT Thermocouple Fitting	26-0862	2
40	1/4" Union Elbow Tube Fitting	26-0416	2
41	HMI Module Kit	46-3326	1
42	Replacement LED, white	26-5783	1
43	Replacement LED, red	26-5786	2
44	Replacement LED, yellow	26-5784	4
45	Replacement LED, green	26-5785	1
46	Mounting Clip for PLC	26-6884	2

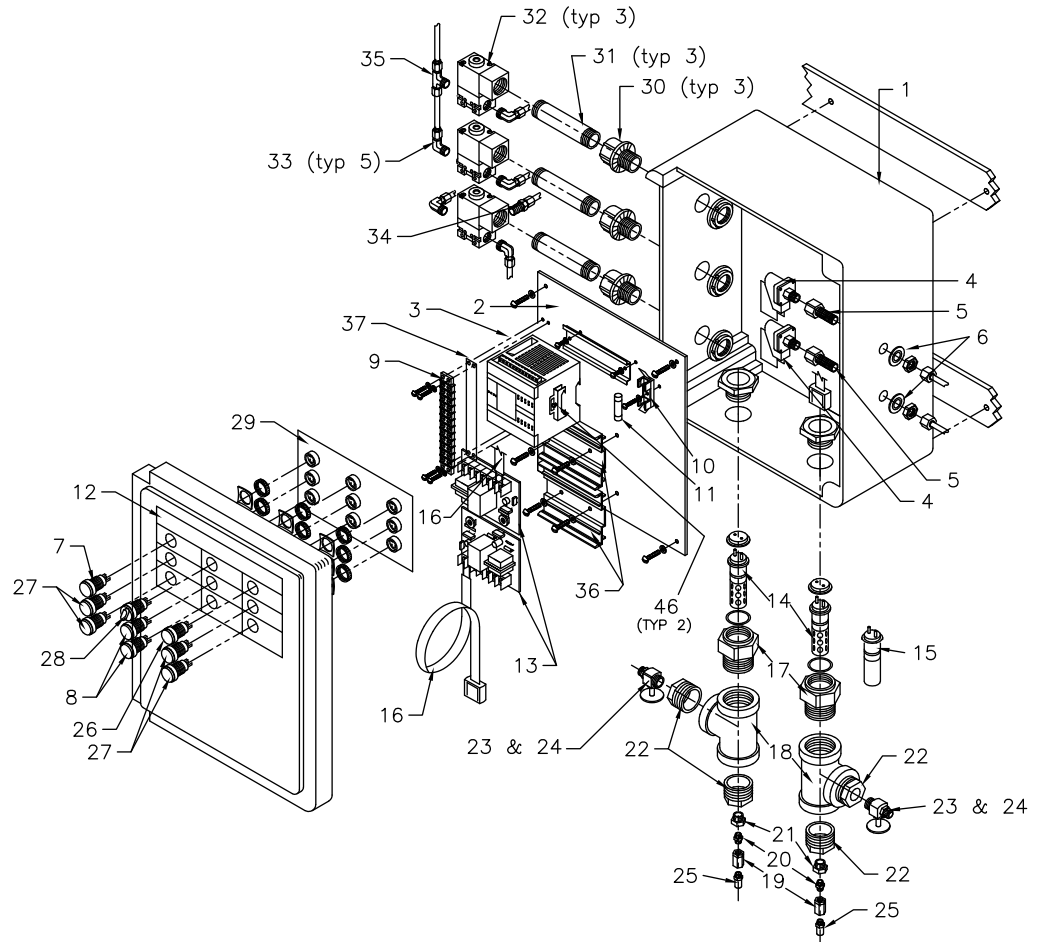
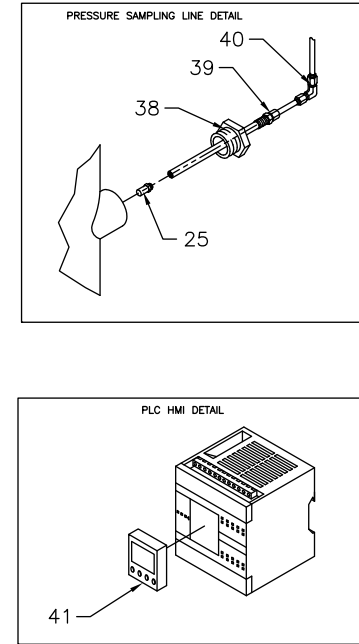

12.6 REPLACEMENT PARTS HL-200 through HL-800

ITEM	DESCRIPTION	HL-200		HL-250		HL-375		HL-500		HL-650		HL-800	
		PART NO.	QTY	PART NO.	QTY	PART NO.	QTY	PART NO.	QTY	PART NO.	QTY	PART NO.	QTY
1	Inlet Transfer Valve	14-0837	1	14-0837	1	14-0837	1	14-0837	1	14-0838	1	14-0838	1
a	Seat & Seal Kit for Inlet Transfer Valve	26-0641	1	26-0641	1	26-0641	1	26-0641	1	26-0642	1	26-0642	1
b	Position Indicator Kit for Inlet Transfer Valve	26-1052	1	26-1052	1	26-1052	1	26-1052	1	26-1053	1	26-1053	1
c	Shuttle Assembly Kit for Inlet Transfer Valve	26-1037	1	26-1037	1	26-1037	1	26-1037	1	26-1038	1	26-1038	1
2	Check Valve	14-1788	2	14-1788	2	14-1788	2	14-1788	2	14-1805	2	14-1805	2
3	Purge Valve	14-1841	2	14-1841	2	14-1801	2	14-1801	2	14-2123	2	14-2123	2
a	Diaphragm & Seal Kit for Purge Valve	26-5687	2	26-5687	2	26-5690	2	26-5690	2	n/a	n/a	n/a	n/a
b	Internal Repair Kit for Purge Valve	26-5686	2	26-5686	2	26-5689	2	26-5689	2	n/a	n/a	n/a	n/a
c	Spring Kit for Purge Valve	26-5688	2	26-5688	2	26-5691	2	26-5691	2	n/a	n/a	n/a	n/a
4	Diffuser basket	46-0224	4	46-0224	4	46-0224	4	46-0224	4	26-5656	4	26-5656	4
5	Stud	28-0409	4	28-0409	4	28-0409	4	28-0409	4	28-0412	4	28-0412	4
6	Sintered Filter	26-1014	1	26-1014	1	26-1014	1	26-1014	1	26-1014	1	26-1014	1
7	Leg Base	46-2347	2	46-2347	2	46-2347	2	46-2347	2	46-2348	2	46-2348	2
8	Leg	46-2345	2	46-2345	2	46-2345	2	46-2345	2	46-2346	2	46-2346	2
9	Purge Exhaust Muffler	26-3262	2	26-3262	2	26-3284	2	26-3284	2	26-3149	2	26-3149	2
a	Element, purge exhaust muffler	26-5774	2	26-5774	2	26-5775	2	26-5775	2	26-5776	2	26-5776	2
10	Control Air Filter	26-6830	1	26-6830	1	26-6830	1	26-6830	1	26-6830	1	26-6830	1
a	Element, control air filter	26-6831	1	26-6831	1	26-6831	1	26-6831	1	26-6831	1	26-6831	1
11	Purge Metering Valve	14-0474	1	14-0474	1	14-0475	1	14-0475	1	26-0359	1	26-0359	1
12	Pneumatic Limit Switch (set)	14-0797	1	14-0797	1	14-0797	1	14-0797	1	14-0797	1	14-0797	1
13	Manifold Block w/Pneumatic Limit Switches	14-1037	1	14-1037	1	14-1037	1	14-1037	1	14-1037	1	14-1037	1
14	Desiccant	33-0237	-	-	-	-	-	-	-	-	-	-	-
	Activated Alumina, 1/8" dia, 25# pail	n/a	9	33-0237	11	33-0237	2	33-0237	7	n/a	n/a	33-0237	6
	Activated Alumina, 1/8" dia., 50# bag	n/a	n/a	n/a	n/a	n/a	n/a	n/a	n/a	n/a	n/a	n/a	n/a
	Activated Alumina, 1/8" dia., 375# drum	45-0201	n/a	n/a	n/a	33-0320	1	33-0320	1	33-0320	2	33-0320	2
15	Touch-Up Paint, 9oz. spray can	81-1715	1	45-0201	1	45-0201	1	45-0201	1	45-0201	1	45-0201	1
16	OPTIONAL SAFETY RELIEF VALVE (set)		1	81-1715	1	81-1716	1	81-1717	1	81-1718	1	81-1719	1

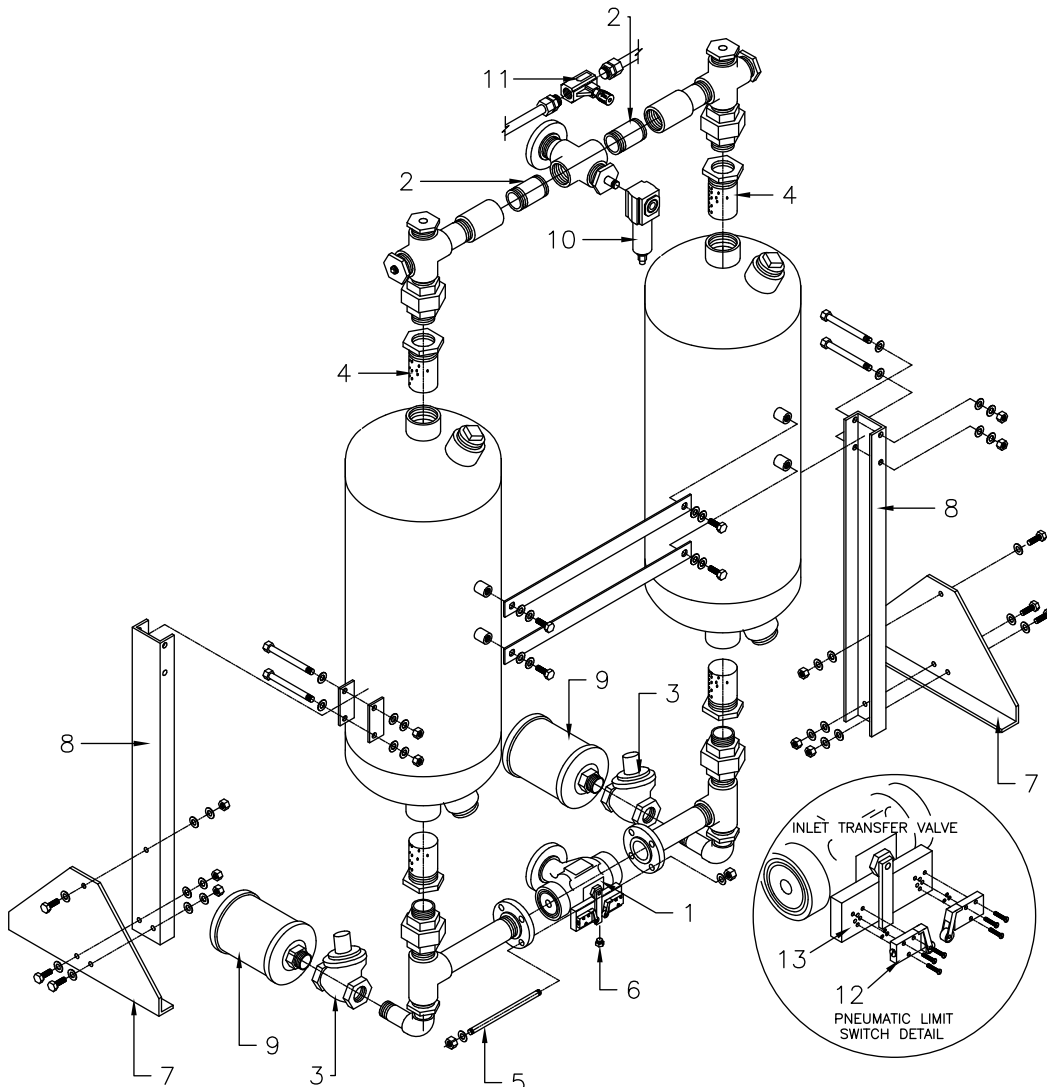

12.7 REPLACEMENT PARTS HL-1000 through HL-1250

ITEM	DESCRIPTION	HL-1000		HL-1250	
		PART NO.	QTY	PART NO.	QTY
1	Inlet Transfer Valve	14-0838	1	14-0838	1
a	Seat & Seal Kit for Inlet Transfer Valve	26-0642	1	26-0642	1
b	Position Indicator Kit for Inlet Transfer Valve	26-1053	1	26-1053	1
c	Shuttle Assembly Kit for Inlet Transfer Valve	26-1038	1	26-1038	1
2	Check Valve	14-1826	2	14-1826	2
3	Purge Valve	14-2120	2	14-2120	2
4	Gasket	18-0217	8	18-0217	8
5	Stud	28-0412	4	28-0412	4
6	Sintered Filter	26-1014	1	26-1014	1
7	Leg Base	46-2348	2	46-2348	2
8	Leg	46-2346	2	46-2346	2
9	Purge Exhaust Muffler	26-3149	2	26-3149	2
a	Element, purge exhaust muffler	26-5776	2	26-5776	2
10	Control Air Filter	26-6830	1	26-6830	1
a	Element, control air filter	26-6831	1	26-6831	1
11	Purge Metering Valve	26-0359	1	26-0359	1
12	Pneumatic Limit Switch (set)	14-0797	1	14-0797	1
13	Manifold Block w/Pneumatic Limit Switches	14-1037	1	14-1037	1
14	Desiccant		-		-
	Activated Alumina, 1/8" dia., 25# pail	n/a	n/a	33-0237	10
	Activated Alumina, 1/8" dia., 50# bag	n/a	n/a	n/a	n/a
	Activated Alumina, 1/8" dia., 375# drum	33-0320	3	33-0320	3
15	Touch-Up Paint, 9oz. spray can	45-0201	1	45-0201	1
16	OPTIONAL SAFETY RELIEF VALVE (set)	81-1720	1	81-1721	1

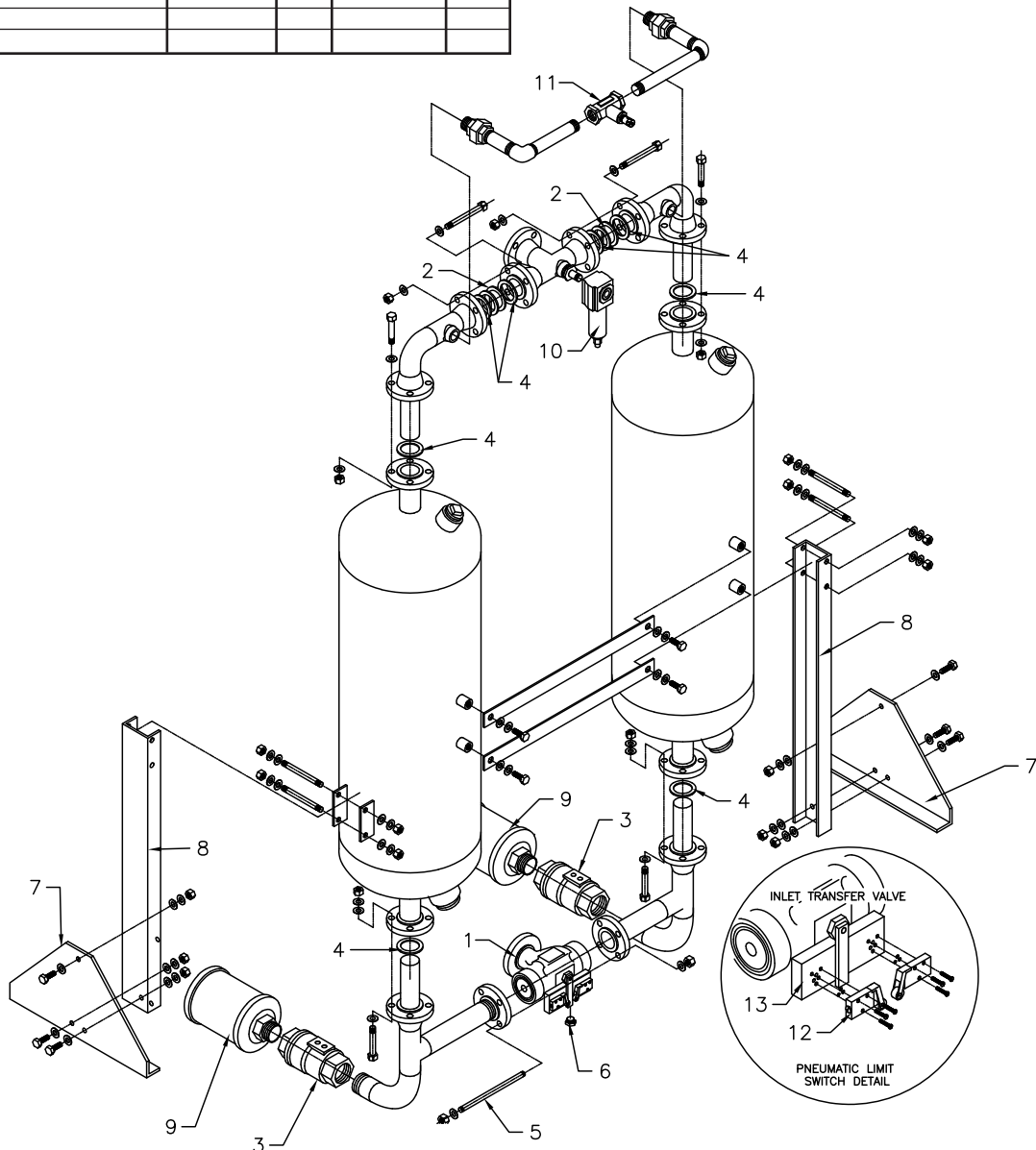

12.8 REPLACEMENT PARTS HL-1500 through HL-2000

ITEM	DESCRIPTION	HL-1500		HL-1750		HL-2000	
		PART NO.	QTY	PART NO.	QTY	PART NO.	QTY
1	Inlet Transfer Valve	14-0839	1	14-0839	1	14-0839	1
a	Seat & Seal Kit for Inlet Transfer Valve	26-0643	1	26-0643	1	26-0643	1
b	Position Indicator Kit for Inlet Transfer Valve	26-1054	1	26-1054	1	26-1054	1
c	Shuttle Assembly Kit for Inlet Transfer Valve	26-1039	1	26-1039	1	26-1039	1
2	Check Valve	14-1827	2	14-1827	2	14-1827	2
3	Purge Valve	14-1832	2	14-1832	2	14-1832	2
a	Diaphragm & Seal Kit for Purge Valve	26-6024	2	26-6024	2	26-6024	2
b	Internal Repair Kit for Purge Valve	26-6026	2	26-6026	2	26-6026	2
c	Spring Kit for Purge Valve	26-6031	2	26-6031	2	26-6031	2
4	Gasket	18-0227	12	18-0227	12	18-0227	12
5	Stud	28-0413	4	28-0413	4	28-0413	4
6	Sintered Filter	26-1014	1	26-1014	1	26-1014	1
7	Purge Exhaust Muffler	26-0366	2	26-0366	2	26-0366	2
a	Element, purge exhaust muffler	26-5777	4	26-5777	4	26-5777	4
8	Control Air Filter	26-6830	1	26-6830	1	26-6830	1
a	Element, control air filter	26-6831	1	26-6831	1	26-6831	1
9	Purge Metering Valve	26-0359	1	26-0359	1	26-0359	1
10	Pneumatic Limit Switch (set)	14-0797	1	14-0797	1	14-0797	1
11	Manifold Block w/Pneumatic Limit Switches	14-1037	1	14-1037	1	14-1037	1
12	Desiccant		-		-		-
	Activated Alumina, 1/8" dia, 25# pail	33-0237	10	33-0237	4	33-0237	n/a
	Activated Alumina, 1/8" dia., 50# bag	n/a	n/a	n/a	n/a	n/a	n/a
	Activated Alumina, 1/8" dia., 375# drum	33-0320	4	33-0320	5	33-0320	6
13	Touch-Up Paint, 9oz. spray can	45-0201	1	45-0201	1	45-0201	1
14	OPTIONAL SAFETY RELIEF VALVE (set)	81-1722	1	81-1722	1	81-1723	1
15	Regulator for Purge Valve	26-0308	2	26-0308	2	26-0308	2

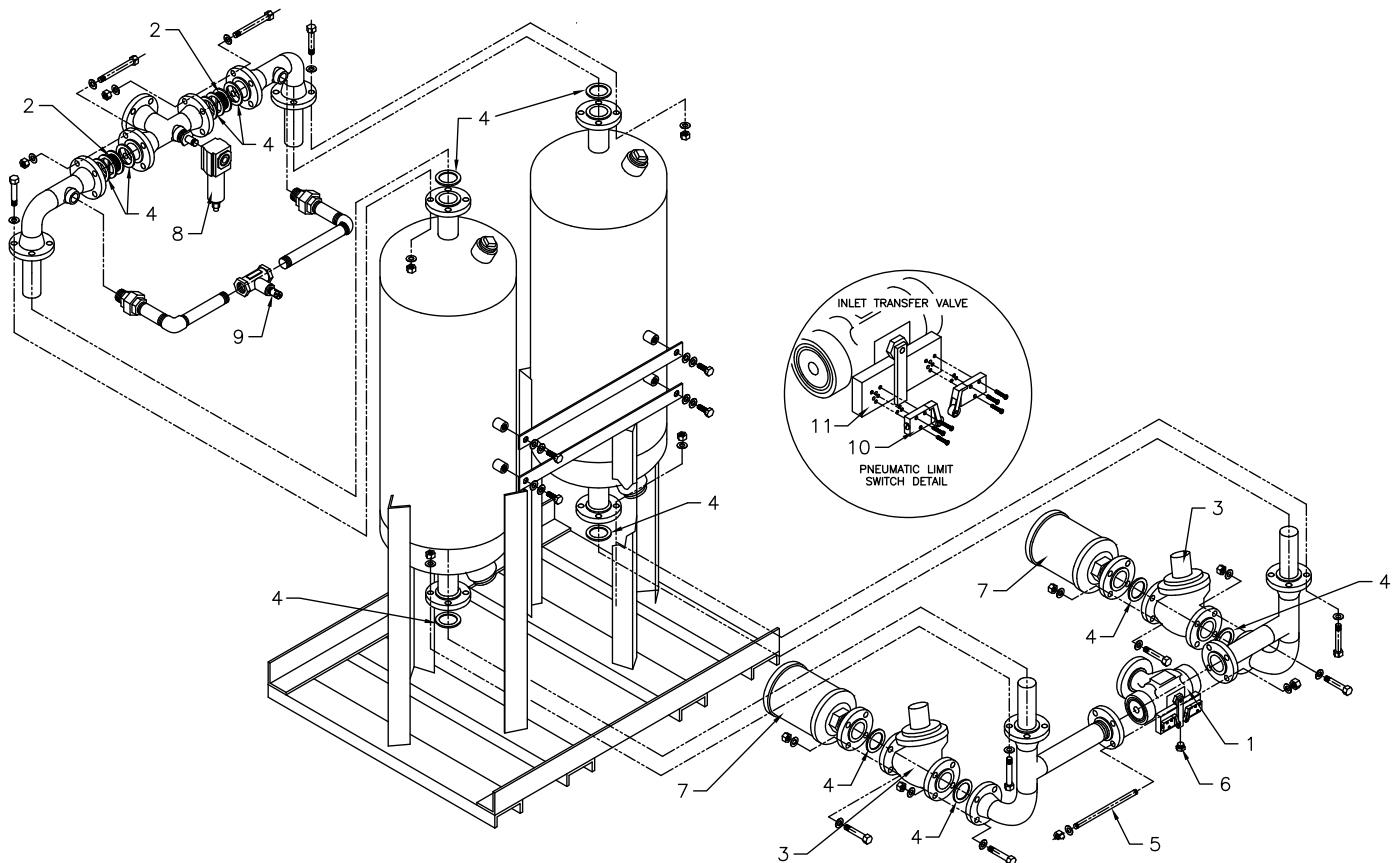

12.9 1-1/2" INLET TRANSFER VALVE (HL-200 through HL-500)

REPAIR KITS	1-1/2"
SEAT & SEAL KIT	26-0641
POSITION INDICATOR KIT	26-1052
SHUTTLE ASSEMBLY KIT	26-1037
PNEUMATIC LIMIT SWITCH SET	14-0797
MANIFOLD BLOCK WITH PNEUMATIC LIMIT SWITCHES	14-1037

12.10 2-1/2" & 3" INLET TRANSFER VALVES
 (2-1/2" HL-650 through HL-1250)
 (3" HL-1500 through HL-2000)

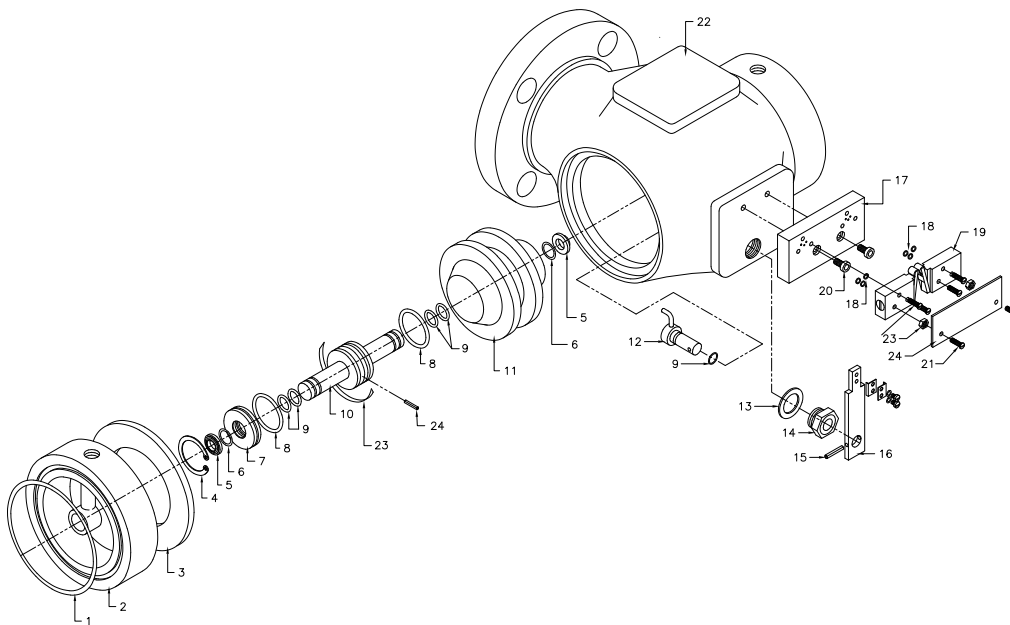

ITEM	QTY	DESCRIPTION
1	2	Flange O-Ring
2	2	Flange Support Ring
3	2	Shuttle Seat
4	1	Snap Ring
5	2	Wiper Ring
6	2	Sealing O-Ring
7	1	Removable End Plate
8	2	Sealing O-Ring
9	5	Sealing O-Ring
10	1	Shuttle Stem
11	1	Shuttle
12	1	Lever Arm
13	1	Washer
14	1	Bushing
15	1	Roll Pin
16	1	Position Indicator
17	1	Manifold Block
18	6	Sealing O-ring
19	1	Pneumatic Limit Switch (set)
20	2	Cap Screw
21	6	Machine Screw
22	1	Valve Body
23	1	Split Ring
24	1	Roll Pin
25	2	Spacer Nut
26	1	Guard

REPAIR KITS	2-1/2"	3"
SEAT & SEAL KIT Consists of Item Numbers: 1(2), 3(2), 5(2), 6(2), 8(2), 9(5), 13, 18(6) & 23	26-0642	26-0643
POSITION INDICATOR KIT Consists of Item Numbers: 12, 14, & 16	26-1053	26-1054
SHUTTLE ASSEMBLY KIT Consists of Item Numbers: 4, 7, 10, 11, & 24	26-1038	26-1039
PNEUMATIC LIMIT SWITCH SET Consists of Item Numbers: 19	14-0797	14-0797
MANIFOLD BLOCK WITH PNEUMATIC LIMIT SWITCHES Consists of Item Numbers: 17, 19, & 21	14-1037	14-1037

12.11 1" PURGE VALVE (HL-200 & HL-250)

ITEM	QTY	DESCRIPTION	ITEM	QTY	DESCRIPTION
1	1	Body 1" NPT	13	1	Cap (cast iron)
2	2	Seat (cast brass)	14	1	Upper Diaphragm Plate
3	2	Hex Lock Nut (1/4-28)	15	1	Lockwasher Set (1/4")
4	1	Disc Plate	16	1	O-Ring (AFLAS)
5	1	O-Ring (viton)	17	1	O-Ring Retainer (brass)
6	1	Disc Spacer (brass)	18	1	O-Ring (viton)
7	1	Disc (hycar)	19	1	Hex HD. Cap Screw (1/4-20 x 7/8)
8	1	Disc Holder (brass)	20	1	Hex Nut (1/4-20)
9	2	O-Ring (viton)	21	1	Retainer Nut
10	1	Shaft	22	1	SQ.HD. Pipe Plug (1/4" NPT)
11	1	Lower Diaphragm Plate	23	1	O-Ring (viton)
12	1	Diaphragm (Buna N/nylon)	24	1	Spring

REPAIR KITS		PART NO.
DIAPHRAGM & SEAL KIT Consists of Item Numbers: 3(2), 5, 7, 9(2), 12, 15, 16 & 18		26-5687
INTERNAL REPAIR KIT Consists of Item Numbers: 4, 6, 8, 10, 11, 14 & 17 and "DIAPHRAGM AND SEAL KIT "		26-5686
SPRING KIT Consists of Item Number: 24		26-5688
SEAT REMOVAL TOOL		26-5873
O-RING RETAINER REMOVAL TOOL		26-5874

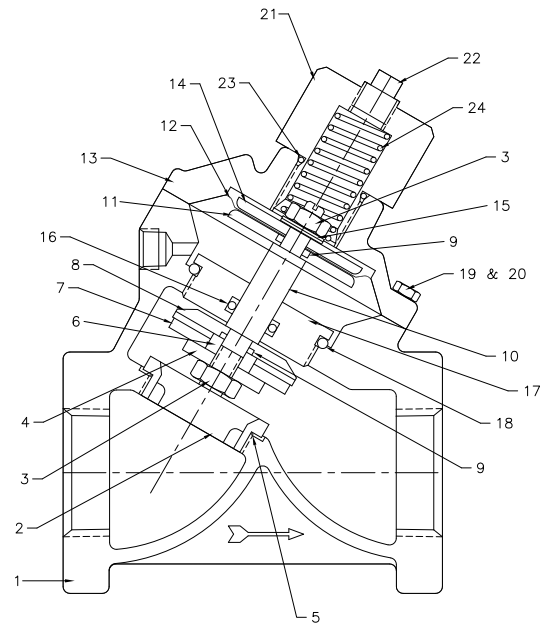

12.12 1-1/2" PURGE VALVE (HL-375 & HL-500)

ITEM	QTY	DESCRIPTION	ITEM	QTY	DESCRIPTION
1	1	Body 1-1/2" NPT	13	1	Lockwasher Set (1/4")
2	1	Seat (cast brass)	14	1	Cap (cast iron)
3	1	Disc Plate	15	1	Shaft
4	2	Hex Lock Nut (1/4-28)	16	1	O-Ring Retainer (brass)
5	1	O-Ring (viton)	17	1	O-Ring (viton)
6	1	Disc Spacer (brass)	18	2	O-Ring (AFLAS)
7	1	Disc (hycar)	19	1	Hex HD. Cap Screw (1/4-20 x 1-1/8)
8	1	Disc Holder (brass)	20	1	Hex Nut (1/4-20)
9	2	O-Ring (viton)	21	1	Retainer Nut
10	1	Lower Diaphragm Plate	22	1	SQ.HD. Pipe Plug (1/8" NPT)
11	1	Diaphragm (Buna N/nylon)	23	1	O-Ring (viton)
12	1	Upper Diaphragm Plate	24	1	Spring

REPAIR KITS		PART NO.
DIAPHRAGM & SEAL KIT Consists of Item Numbers: 4(2), 5, 7, 9(2), 11, 13, 17 & 18(2)		26-5690
INTERNAL PARTS KIT Consists of Item Numbers: 3, 6, 8, 10, 12, 15 & 16 and "DIAPHRAGM AND SEAL KIT "		26-5689
SPRING KIT Consists of Item Number: 24		26-5691
SEAT REMOVAL TOOL		26-5875
O-RING RETAINER REMOVAL TOOL		26-5876

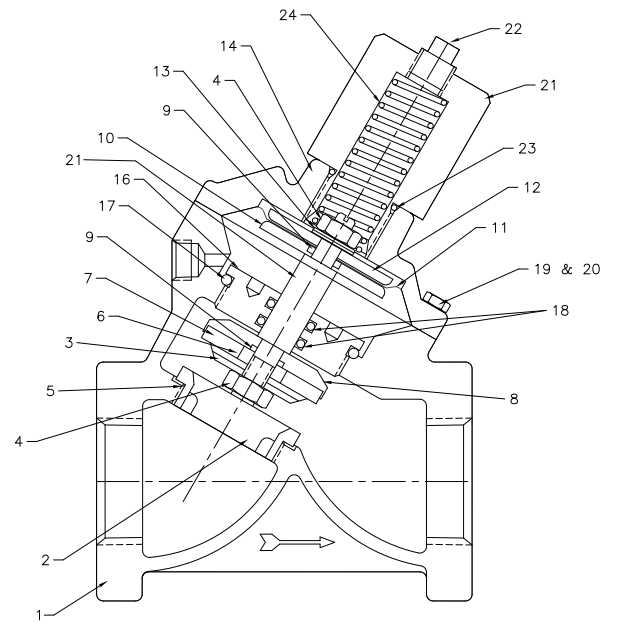

12.13 1-1/2" PURGE VALVE (HL-650 & HL-800)

REPAIR KITS		PART NO.
REBUILD KIT		26-6929

12.14 2" PURGE VALVE (HL-1000 & HL-1250)

REPAIR KITS		PART NO.
REBUILD KIT		26-6853

12.15 3" PURGE VALVE (HL-1500 through HL-2000)

ITEM	QTY	DESCRIPTION
1	1	Body 3" Flanged
2	1	Seat (cast brass)
3	1	Disc Plate
4	2	Hex Lock Nut (5/16-24)
5	1	Disc Spacer (brass)
6	1	O-Ring (viton)
7	1	Disc (hycar)*
8	1	Disc Holder (brass)
9	2	O-Ring (viton)
10	1	Shaft
11	1	Diaphragm
12	1	Cap (cast iron)
13	1	Upper Diaphragm Plate

ITEM	QTY	DESCRIPTION
14	1	Lockwasher Set
15	2	Hex HD. Cap Screw (3/8-16 x 7/8)
16	1	Lower Diaphragm Plate
17	1	O-Ring Retainer (brass)
18	1	O-Ring (viton)
19	2	O-Ring (AFLAS)
20	6	Hex HD. Cap Screw (3/8-16 x 1-1/2)
21	6	Hex Nut (3/8-16)
22	1	Gasket (copper)
23	1	Retainer Nut
24	1	Square Head Plug 1/8" NPT
25	1	Spring

REPAIR KITS	PART NO.
DIAPHRAM & SEAL KIT Consists of Item Numbers: 4(2), 6, 7, 9(2), 11, 14, 18 & 19(2)	26-6024
INTERNAL REPAIR KIT Consists of Item Numbers: 3, 5, 8, 10, 13, 16 & 17 and "DIAPHRAGM AND SEAL KIT "	26-6026
SPRING KIT Consists of Item Number: 25	26-6031

* Disc is directional and should be installed with 3/64 smooth nitrile coating towards seat (away from disc holder)

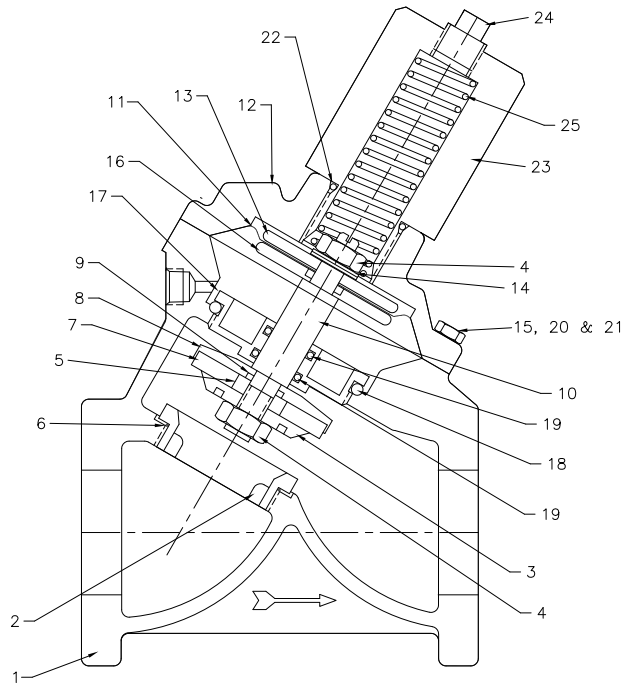

12.16 OPTIONAL 230 VOLT TRANSFORMER

ITEM	DESCRIPTION	PART NO.	QTY
1	Terminal Strip	26-0250	1
2	Transformer	26-5751	1

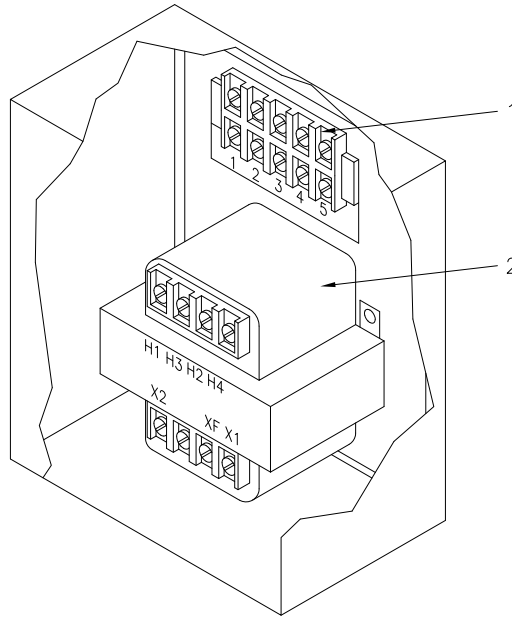

14.17 HOW TO ORDER PARTS

To order parts for your dryer contact your local VAN AIR representative or the representative where you purchased the dryer from. If you cannot find a local representative or have problems ordering the parts, contact the factory.

When contacting your local VAN AIR representative or the factory, the following information is necessary:

- Dryer model**
- Dryer serial number**
- Dryer part number**

This information can be found on the dryer data tag. The data tag is located inside the door of the control box.

The Service Department can be reached by calling 888-606-9303 or faxing 814-774-3482. Hours are 8:00 AM EST to 5:00 PM EST, Monday through Friday.

SAFETY PRECAUTIONS

Safety is everybody's business and is based on your use of good common sense. All situations or circumstances cannot always be predicted and covered by established rules. Therefore, use your past experience, watch out for safety hazards and be cautious.

⚠ DANGER	⚠ DANGER	⚠ WARNING	⚠ WARNING
			
<p>DISCHARGE AIR USED FOR BREATHING WILL CAUSE SEVERE INJURY OR DEATH. CONSULT FILTRATION SPECIALIST FOR ADDITIONAL FILTRATION AND TREATMENT EQUIPMENT TO MEET HEALTH AND SAFETY REGULATIONS.</p>	<p>AIR AND OIL UNDER PRESSURE WILL CAUSE SEVERE PERSONAL INJURY OR DEATH. SHUT DOWN COMPRESSOR AND RELIEVE SYSTEM OF ALL PRESSURE BEFORE REMOVING VALVES, CAPS, PLUGS, FITTINGS, BOLTS AND FILTERS.</p>	<p>ELECTRICAL SHOCK FROM IMPROPER GROUNDING CAN CAUSE INJURY OR DEATH.</p> <p>GROUND UNIT AND RELATED EQUIPMENT ACCORDING TO NATIONAL ELECTRICAL CODE AND LOCAL REGULATIONS.</p>	<p>READ THE OPERATOR'S MANUAL BEFORE STARTING OR SERVICING THIS UNIT. FAILURE TO ADHERE TO INSTRUCTIONS CAN RESULT IN SEVERE PERSONAL INJURY OR DEATH. REPLACEMENT MANUALS CAN BE DOWNLOADED AT www.vanairsystems.com.</p>