

## HPRN Series

Refrigerated Type Compressed Air Dryers

Models: HPRN75, HPRN100, HPRN125, HPRN150-2, HPRN200-2, HPRN250-2, HPRN300-2, HPRN400-2, HPRN500

FORM NO.: 7433659 REVISION: 05/2016

READ AND UNDERSTAND THIS MANUAL PRIOR TO OPERATING OR SERVICING THIS PRODUCT.



# Contents

GENERAL SAFETY INFORMATION .....	2
RECEIVING, MOVING, AND UNPACKING .....	2
INSTALLATION .....	3
INSTRUMENTATION .....	4
START-UP/OPERATION.....	6
SHUTDOWN.....	6
MAINTENANCE.....	6
FIELD SERVICE GUIDE.....	8
ENGINEERING DATA .....	9
GENERAL ARRANGEMENT DRAWINGS	
Models HPRN75 through HPRN150-2.....	10
Models HPRN200-2 through HPRN250-2 .....	11
Models HPRN300-2 through HPRN500.....	12
ELECTRICAL SCHEMATICS	
Model HPRN75.....	13
Models HPRN100 through HPRN125 .....	13
Model HPRN150-2 .....	14
Models HPRN200-2 through HPRN400-2 .....	14
Model HPRN500.....	15
AIR AND REFRIGERANT FLOW SCHEMATIC.....	16
REPLACEMENT PARTS.....	17
WARRANTY .....	19

## GENERAL SAFETY INFORMATION

### 1. PRESSURIZED DEVICES:

This equipment is a pressure containing device.



- Do not exceed maximum operating pressure as shown on equipment serial number tag.
- Make sure equipment is depressurized before working on or disassembling it for service.

### 2. ELECTRICAL:

This equipment requires electricity to operate.



- Install equipment in compliance with all applicable electrical codes.
- Standard equipment is supplied with electrical enclosures not intended for installation in hazardous environments.
- Disconnect power supply to equipment when performing any electrical service work.

### 3. BREATHING AIR:

- Air treated by this equipment may not be suitable for breathing without further purification.



Refer to applicable standards and specifications for the requirements for breathing quality air.

## RECEIVING, MOVING, AND UNPACKING

### A. RECEIVING

This shipment has been thoroughly checked, packed and inspected before leaving our plant. It was received in good condition by the carrier and was so acknowledged.

Check for Visible Loss or Damage. If this shipment shows evidence of loss or damage at time of delivery to you, insist that a notation of this loss or damage be made on the delivery receipt by the carrier's agent.

### B. UNPACKING

Check for concealed loss or damage. When a shipment has been delivered to you in apparent good order, but concealed damage is found upon unpacking, notify the carrier immediately and insist on his agent inspecting the shipment. Concealed damage claims are not our responsibility as our terms are F.O.B. point of shipment.

### C. MOVING

In moving or transporting dryer, do not tip dryer onto its side.

### D. STORAGE

**IMPORTANT:** Do not store dryer in temperatures above 130°F (54.4°C).

## INSTALLATION

### Ambient Air Temperature

Locate the dryer indoors where the ambient air temperature will be between 40°F and 110°F. Intermittent operation at ambient temperatures up to 113°F will not damage the dryer but may result in a higher dew point or dryer shutdown due to high refrigerant discharge pressure (see Field Service Guide).

Do not operate air-cooled dryers at ambient air temperatures below 40°F. Such operation may result in low suction pressure, causing freeze-up.

### Location and Clearance

Mount the dryer on a level base. If the base vibrates, bolt the unit down using vibration dampeners. Allow at least 24 inches clearance on the sides and the front of the dryer for cooling airflow and for service access.

### System Arrangement

Liquid water in the inlet air will adversely affect the performance of the dryer. Install the dryer downstream of an aftercooler or separator so that the temperature of the dryer inlet air does not exceed 120°F and the inlet air does not contain any liquid water.

If the compressed airflow is relatively constant and does not exceed the dryer flow rating, it is recommended that the dryer be located downstream of the receiver tank. If the nature of the application is such that the air demand regularly exceeds the dryer flow rating, it is recommended that the dryer be located upstream of the receiver.

For safety and convenience, install inlet and outlet shutoff valves and depressurization valves. These valves allow the dryer to be isolated and depressurized for servicing. Bypass piping may be installed around the dryer for uninterrupted airflow when the dryer is serviced. If the compressed air operation cannot tolerate undried air for short periods, install a second dryer in the bypass line.

Compressed air systems commonly require filters to remove compressor oils, particulates, condensed liquids and other contaminants. When an oil-removal filter is used, it should be installed downstream of the refrigerated dryer. At this location, the life of the replaceable filter element is prolonged since some of the entrained oil is removed by the dryer and drained through the separator.

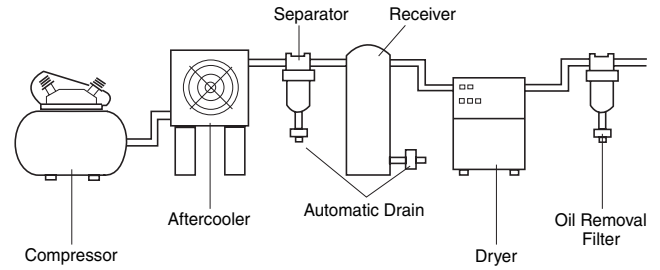

**TYPICAL COMPRESSED AIR SYSTEM**

### Piping and Connections

Piping must be furnished by the user unless otherwise specified. Connections and fittings must be rated for the maximum operating pressure given on the dryer data plate and must be in accordance with applicable codes. Support all piping; do not allow the weight of any piping to stress the dryer or filter connections. Inlet and outlet shutoff valves and a valved bypass valve are recommended. Piping should be at least the size of the inlet and outlet connections to minimize pressure drop in the air system. See Engineering Data section for dryer inlet and outlet connections.

### Removing Condensate

Condensate must be drained from the dryer to prevent re-entrainment. The dryers are equipped with automatic drain valves and internal drain hoses up to the drain connections on the dryer cabinets. The user must install a separate discharge line at the drain connection to carry off condensate to an environmentally approved condensate collection/disposal system. Piping or copper tubing 1/2 inch or larger is recommended for condensate discharge lines. Install the drain lines so that condensate can be seen as it drains.

### Electrical Connections

The dryers are constructed according to NEMA Type 1 electrical standards. Field wiring must comply with local and national fire, safety and electrical codes. Installation must be in accordance with the National Electrical Code. Confirm that your line voltage is the same as the voltage listed on the dryer data plate. Refer to Figure 1 for electrical schematics.

**⚠ CAUTION** Operation of dryers with improper line voltage constitutes abuse and could affect the dryer warranty.

## INSTRUMENTATION

### ON/OFF Switch

The dryer is equipped with an ON/OFF switch on the front panel. A light signals when the dryer is on.

### Dew Point Indicator (75 through 150 scfm models)

All dryers are equipped with a dew point indicator which indicates dryer conditions as follows:

It is normal for the dew point indicator to be in the red zone when the dryer is first turned on and then move to the green zone when the dryer reaches its normal operating temperature. If this indicator is in the red zone during normal operation, turn the dryer off to avoid compressor damage. Refer to the Field Service Guide for additional information, or call your local distributor.

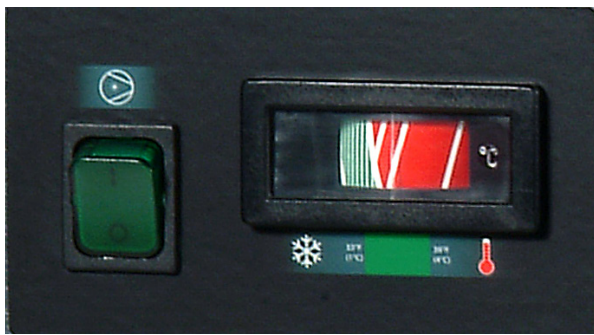

### Dew Point Indicator

(Models HPRN75, HPRN100, HPRN125 and HPRN150-2)

### Dryer System Monitor (DSM) (200 through 500 scfm models)

The Dryer System Monitor (DSM) has LED type dew point temperature indicator and operating time control for the electronic drain valve. When the dryer is running normally, the green LED will illuminate. If the red LED is illuminated, there is a need for the dryer's operating condition to be checked. If all LEDs are illuminated, the sensor for the dew point temperature indicator has malfunctioned.

The automatic drain valve controls allow the period of drain opening to be set from 1 second to 9 seconds and drain valve closed time to be set from 0.5 minutes to 15 minutes. When the Drain Push-to-Test button (5) is pushed for one (1) second, the Drain LED (6) will illuminate and the drain port opens with a click.

**Dryer System Monitor**  
(Models HPRN200-2, HPRN250-2, HPRN300-2, HPRN400-2 and HPRN500)

1. On/Off Switch: Press the top of the switch (I) to turn the dryer on. Press the bottom of the switch (O) to turn the dryer off. When the dryer is on, the switch is illuminated.
2. Dew Point Temperature Indicator: Main portion of the graphic for the dew point temperature scale. Green indicates low, red indicates high.
3. Compressor On Light / On Time Setting Mode: Dual purpose LED indicating light. Illuminates as solid light when compressor is ON. Blinks On and Off during setup of the On Time Set Points for the Automatic Drain Valve.
4. Selection Button: During set up of the Automatic Drain Valve, When pressed, sequences from left to right.
5. Drain Push-to-Test Button / Enter Button:
  - a) Drain Push-to-Test button. When the button is pressed, the drain valve opens for the time corresponding to the setting established during Drain Valve setup.
  - b) Enter button. Stores the "On Time" and "off Time" drain valve settings established during Drain Valve setup
6. Drain LED / Off Time Setting Mode: Dual purpose LED indicating light. Illuminates as solid light when Drain is closed. Blinks On and Off during setup of the Off Time Set Points for the Automatic Drain Valve.
7. This is a graphic symbol for the Air Dryer compressor. It simply indicates that the switch is used to turn the compressor (dryer) on and off.
8. Part of the graphic for the dew point temperature scale. The snowflake indicates the low (cold) end of the scale.
9. Part of the graphic for the dew point temperature scale. The thermometer indicates the high (hot) end of the scale.
10. This is a graphic symbol for the Drain Valve.

## Automatic Drain Valve

All models are equipped with an electronic drain valve that automatically discharges condensate from the dryer. Drain valve operation is controlled by a drain valve timer. The drain valve opening can be set from 0.5 seconds to 9 seconds. The drain cycle can be set from 0.5 minutes to 15 minutes.

Models HPRN75 through HPRN150-2 have the timer mounted directly on the drain valve.

For models HPRN200-2 through HPRN500, drain valve adjustments are made on the Dryer System Monitor:

1. Press the Selection (4) and Enter (5) buttons at the same time for 3 seconds, the On Time Setting Mode LED (3) will start to blink, and the illuminated LED on the Dew Point Temperature Indicator LED (2) will identify the factory setting for "On Time". (See table)
2. Press and release the Selection button (4) to sequence from left to right until reaching your selection. The red LED is not used.
3. To store the "On Time", press the Enter button (5) and set the "Off Time" using step 2.
4. To store the "Off Time", press the Enter button (5) again.
5. Exiting the Program will cause the Timer Drain to discharge and begin a new cycle.

NOTE: Failure to perform step 3 within 10 seconds of completing step 2 will cause the unit to revert back to the previous setting.

LED (2) Position	1st	2nd	3rd	4th	5th	6th	7th	8th	9th
On Time (sec)	1	2	3	4	5	6	7	8	Continuous (Drain Trap Option)
Off Time (min)	0.5	1	2	3	5	7	9	10	15

## Electronic Drain Valve Adjustment

The automatic drain valve has been pre-programmed at the factory for your specific HPRN Series dryer. Programming is based upon a minimum of 100 psi saturated inlet air pressure and maximum energy efficiency. Generally no adjustment to the timer is necessary.

CAUTION: If water is present downstream of the dryer, always verify that and condensate drains installed upstream of the dryer are draining properly before attempting to adjust the timer settings.

1. For minimum inlet air pressures that fall between column values the setting for the lower pressure is recommended. (i.e. select the 100 psi column values for 124 psi inlet pressure.)
2. Where the dryer is consistently operating at less than maximum capacity, it may be possible to alter the timer set points to minimize air loss. Discretionary adjustments to the dryer should only be made on a hot, humid day when the maximum expected air load is flowing through the dryer. Failure to do so may prevent the condensate from draining completely when operating under peak load conditions.

**Drain Timer**  
(Models HPRN75, HPRN100, HPRN125 and HPRN150-2)

1. Adjustment knob for the drain valve open time. The values on the dial correspond to the time in seconds that the valve is open in each drain cycle.
2. Adjustment knob for the drain valve closed time. The values on the dial correspond to the time in minutes that the valve is closed in each drain cycle.
3. LED to indicate when the drain valve is open.
4. Drain test button. When the button is pressed, the drain valve opens for the time corresponding to the setting on item 1.
5. LED to indicate when the drain valve is closed.

	Inlet Pressure (psig)												
	75		100*		125		150		200		225		
	On (sec)	Off (min)	On (sec)	Off (min)	On (sec)	Off (min)	On (sec)	Off (min)	On (sec)	Off (min)	On (sec)	Off (min)	
Dryer Model	HPRN75	2	3	2	3	2	5	2	6	2	9	2	9
	HPRN100	2	2	2	2	2	4	2	6	2	7	2	9
	HPRN125	2	2	2	2	2	3	2	5	2	6	2	7
	HPRN150-2	2	1	2	2	2	3	2	4	2	6	2	7
	HPRN200-2	2	5	2	5	2	7	2	9	2	9	2	9
	HPRN250-2	2	4	2	4	2	6	2	9	2	9	2	9
	HPRN300-2	2	3	2	3	2	5	2	7	2	9	2	9
	HPRN400-2	2	2	2	2	2	4	2	6	2	9	2	9
	HPRN500	2	2	2	2	2	4	2	5	2	7	2	9

\* Recommended and pre-programmed factory settings for each HPRN Series model dryer.

Assumes dryer operates at ISO 7183 (Option A2) conditions: 100°F inlet air temperature, 100 psig operating pressure, 100°F ambient air temperature and 10°F air-cooled after-cooler approach temperature.



## START-UP/OPERATION

Follow the procedure below to start your dryer. Failure to follow the prescribed start-up procedure will invalidate the warranty. If problems arise during start-up, call your distributor.

**⚠ WARNING** Refer to Serial Number Tag for dryer operating capacity. Do not exceed recommended capacity.

Drain connections must be made before the dryer can be operated. The dryers are fully automatic and require no auxiliary controls.

1. Turn the dryer ON/OFF switch to OFF.
2. Check that the main electrical supply voltage matches the voltage specified on the dryer data plate.
3. Check proper connection and support of compressed air lines to the dryer; check bypass valve system, if installed.
4. SLOWLY pressurize the dryer. The outlet valves of the dryer should be closed to prevent flow through the dryer.
5. Turn on the main electrical power to the dryer.
6. Ensure adequate ventilation for air-cooled dryers.

### To start dryer:

1. Turn the power switch to ON. The refrigerant compressor will turn on.
2. Allow the dryer to run 15 minutes. Confirm that the temperature indicators are in the green zone.
3. SLOWLY open the dryer outlet valves permitting flow through the dryer.
4. Confirm that condensate is discharging from the drain valve by pressing the "Push-to Test" button.
5. Check drain valve timing. See Automatic Drain Valve section for drain valve adjustment procedure.
6. Confirm that the inlet air temperature, pressure and airflow to the dryer meet the specified requirements (see Engineering Data section).
7. Confirm that the condensate lines from the drain valve discharge into a collection tank or an environmentally-approved disposal system.

The dryer is designed to run continuously. Let the dryer run even when the demand for compressed air is interrupted; the dryer will not freeze up.

## SHUTDOWN

When the dryer must be shutdown for maintenance or other reasons, use the following procedure.

If electrical repairs must be made:

1. Turn off the power switch.
2. Disconnect the main power supply.
3. Lock out and tag the power supply in accordance with OSHA requirements.

If mechanical repairs are to be made or service is performed, vent the internal pressure of the dryer to atmospheric pressure. Restart the dryer according to the start-up instructions.

**⚠ WARNING** Disconnect power supply and depressurize dryer before servicing. Dismantling or working on any component of the compressed air system under pressure may cause equipment failure and serious personal injury.

## MAINTENANCE

The dryers require little maintenance for satisfactory operation. Good dryer performance can be expected if the following routine maintenance steps are taken.

**⚠ WARNING** Dismantling or working on any component of the compressed air system under pressure may cause equipment failure and serious personal injury. Before dismantling any part of the dryer or compressed air system, completely vent the internal pressure to the atmosphere.

### General

For continued good performance of your refrigerated dryer, all refrigeration system maintenance should be performed by a competent refrigeration mechanic.

**NOTE:** Before corrective maintenance is done during the warranty period, call your local distributor and proceed according to instructions. Refer to the warranty for limits of your coverage.

### Daily Maintenance

Check the operation of the automatic drain valve at least once daily. See the Field Service Guide for remedies to drain valve malfunctions. See the AUTOMATIC DRAIN VALVE section for drain valve adjustment.

### Monthly Maintenance

It is recommended to inspect the condenser coils monthly. If necessary, remove dirt or other particles with compressed air from an OSHA-approved air nozzle that limits its discharge pressure to 30 psig (2.1 kgf/cm<sup>2</sup>).

### Electronic Drain Valve Disassembly and Servicing

The valve body is attached to the valve strainer which is attached to the heat exchanger vessel.

**⚠ CAUTION** Do not disassemble drain valve timer or attempt to repair electrical parts. Replace timer if defective.

The drain valve discharge condensate through a full-port drain opening. The valve body may need to be cleaned under conditions of gross particulate contamination.

To disassemble the drain valve body for cleaning and other maintenance:

1. Turn power switch off.
2. Disconnect main power supply to dryer.
3. Depressurize unit.
4. Lock out and tag power supply in accordance with OSHA requirements.

**⚠ WARNING** If power supply is not connected and unit is not depressurized before disassembly, serious personal injury and valve damage may result.

5. Removes hoses that connect the drain valve to the drain discharge fitting and remove the valve from the drain valve strainer.
6. Remove screw and washer from front of the drain valve.
7. Remove the power supply connector and gasket (with the timer assembly if attached) from the solenoid coil housing. Do not damage or lose the gasket.
8. Remove coil fixing nut from top of solenoid coil housing.
9. Lift solenoid coil housing off solenoid core in valve body.
10. Unscrew solenoid core from valve body.

Once the drain valve is disassembled, the following maintenance can be performed.

1. Inspect internal parts of valve body; clean or replace as required.

**NOTE:** Replace solenoid valve if component damage is observed.

2. Remove debris from valve body.
3. Wipe solenoid core components with a clean cloth or blow out debris with compressed air from an OSHA-approved air nozzle that limits its discharge pressure to 30 psig.
4. Check that the plunger assembly is clean and moves freely in housing.
5. If timer is attached to valve body, check electrical continuity across timer assembly.

To reassemble the drain valve, reverse the sequence of the preceding steps. After the drain valve is reassembled, connect the main power supply to the dryer.

When the dryer is returned to service, check the drain valve for air or condensate leaks; tighten connections as required to correct leaks. Check the drain cycle; adjust the timer according to the procedure in the drain valve adjustment section.

## FIELD SERVICE GUIDE

Problems most frequently encountered with refrigerated dryers are water downstream of the dryer and excessive pressure drop. Most causes can be identified and remedied by following this guide.

**⚠ WARNING** Closed refrigeration systems are potentially dangerous. Work on the refrigeration system must be done only by a competent licensed refrigeration mechanic. Do not release fluorocarbon refrigerants to the atmosphere. Do not discharge liquid refrigerants into floor drains. Refrigerant vapors may accumulate in low places. Inhalation of high concentrations may be fatal. All refrigerants must be recovered per EPA requirements.

Do not smoke when a refrigeration leak is suspected. Burning materials may decompose refrigerants, forming a toxic gas or acids that may cause serious injury and property damage.

Before dismantling any part of the dryer or compressed air system, completely vent the internal pressure to the atmosphere.

PROBLEM	SYMPTOM	POSSIBLE CAUSE	REMEDY
Water Downstream of Dryer	Refrigerant compressor not running.	Loss of power to dryer	Check power supply, fuses and/or breakers. Check for loose connections.
		Dryer turned off.	Check On/Off switch position.
		Dryer overloaded.	Confirm that inlet flow, inlet temperature and inlet pressure are within acceptable range of dryer.
		Condenser clogged with debris.	Check/clean condenser.
		Fan motor inoperative	Check fan motor operation. Replace if necessary.
		Ambient temperature too high.	Verify ambient temperature throughout day.
		High pressure switch activated (models 200 to 500 only)	Press manual reset button to switch to reset button.
		Compressor overheated.	Turn dryer off. Contact local distributor.
	Compressor defective.	Turn dryer off. Contact local distributor.	
	No condensate discharging from dryer.	Drain strainer clogged.	Clean drain strainer.
		Drain valve inoperative.	Check/rebuild drain valve.
		Drain timer or DSM inoperative.	Confirm there is power to the timer or DSM. Replace timer or DSM, if necessary.
		Drain solenoid inoperative.	Confirm there is power to the coil. Replace coil, if necessary.
Condensate discharging from dryer.	Incorrect drain timer setting.	Adjust drain timer - increase open time and/or decrease closed time.	
Liquid water entering dryer.	Aftercooler drain valve malfunction.	Check, repair aftercooler drain valve.	
Excessive Pressure Drop Across Dryer	Frozen condensate in evaporator.	Incorrect constant pressure valve setting.	Contact local distributor.
	Inlet air pressure low.	Upstream restriction in air system.	Check all upstream air system components (valves, regulators, etc.)
	Dryer undersized.	Excessive compressed air flow.	Resize dryer.
Dew Point Indicator Out of Green Zone	Dew Point Indicator Out of Green Zone	Dryer overloaded.	Confirm that inlet flow, inlet temperature and inlet pressure are within acceptable range of dryer.
		Condenser clogged with debris.	Check/clean condenser.
		Loose sensor connection.	Confirm gauge or DSM sensor is tightly connected to dryer tubing.
		Defective gauge, DSM or DSM sensor.	Replace gauge, DSM or DSM sensor.



# ENGINEERING DATA

MODEL	HPRN75	HPRN100	HPRN125	HPRN150-2	HPRN200-2	HPRN250-2	HPRN300-2	HPRN400-2	HPRN500
<b>SPECIFICATIONS</b>									
Rated Capacity <sup>1</sup> - (scfm)	75	100	125	150	200	250	300	400	500
Inlet /Outlet Connections - (inches, NPT)	1	1	1	1	2	2	2	2	2
Dimensions									
Height - (inches)	23.67	23.67	23.67	23.67	29.97	29.97	31.94	31.94	31.94
Width - (inches)	14.28	14.28	14.28	14.28	17.43	17.43	19.39	19.39	21.36
Length - (inches)	32.33	32.33	32.33	34.69	36.66	36.66	43.75	43.75	47.69
Net Weight - (lbs)	106	111	116	132	174	181	228	254	302
Shipping Weight - (lbs)	123	129	135	152	196	204	252	279	328
Power Supply - (V/Ph/Hz)	115/1/60	115/1/60	115/1/60	230/1/60	230/1/60	230/1/60	230/1/60	230/1/60	460/3/60
Refrigerant Compressor Capacity <sup>2</sup> - (BTU/hr)	4,320	5,000	5,000	9,281	14,501	16,241	19,312	25,341	28,040
Input Power - (kW)	0.52	0.65	0.68	0.91	1.53	1.87	2.09	2.83	3.18
Refrigerant Type	R-134a	R-134a	R-134a	R-407c	R-407c	R-407c	R-407c	R-407c	R-407c
Charge <sup>3</sup> - (oz)	16.9	18.7	20.5	26.5	33.5	42.3	45.9	52.9	63.5

<sup>1</sup> Rated Flow Capacity - Conditions for rating dryers are in accordance with ISO 7183 (Option A2). Compressed air at dryer inlet: 100 psig (6.7 barg) and 100°F (38°C); ambient air temperature: 100°F (38°C), operating on 60 Hz power supply.

<sup>2</sup> Compressor capacity @ ASHRAE-T standard : 45°F evaporating temperature, 130°F condensing temperature, 95°F return temperature, 115°F liquid temperature, and 95°F ambient temperature.

<sup>3</sup> Refer to dryer data plate for refrigerant charge.

MINIMUM - MAXIMUM OPERATING CONDITIONS	ALL MODELS
Min.-Max. Inlet Air Pressure (compressed air at inlet to dryer)	43.5 - 232 psig (3 - 16 barg)
Min.-Max. Inlet Air Temperature (compressed air at inlet to dryer)	45°F - 120°F (7°C - 49°C)
Min.-Max. Ambient Temperature	40°F - 109°F (7°C - 43°C)

**NOTE:** Continuous operation in the above maximum and minimum operation conditions is not allowable.

## SUCTION PRESSURE

Refrigerant	Without Airflow
R-134a	31 psig
R-407c	60 psig

## REFRIGERANT PRESSURE SWITCH SETTINGS

Fan Cycle Control			
Fan Pressure Switch Setting			
Model	Refrigerant	Cut-In (psig)	Cut-Out (psig)
75-125	R-134a	199 psig	142 psig
150-500	R-407c	299 psig	213 psig

Refrigerant Compressor Control			
High Pressure Switch Setting			
Sensor Location	Refrigerant	Cut-In	Cut-Out (psig)
Compressor Discharge	R-407c	Manual Reset	201 psig

# GENERAL ARRANGEMENT DRAWINGS

Models HPRN75 through HPRN150-2

MODEL	DIMENSIONS, INCHES (MM)																		CONNECTIONS (INCHES, NPT)
	A	B	C	D	E	F	G	H	I	J	K	L	M	N	O	P	Q	R	
75	2.02 (51.2)	3.79 (96.2)	1.96 (50)	19.26 (489.2)	2.44 (62)	32.33 (821.2)	21.26 (540)	31.15 (791.2)	1.18 (30)	14.28 (362.6)	12.76 (324)	21.70 (551.2)	23.67 (601.2)	2.16 (55)	4.38 (111.2)	2.02 (51.2)	1.18 (30)	1.18 (30)	1
100	2.02 (51.2)	3.79 (96.2)	1.96 (50)	19.26 (489.2)	2.44 (62)	32.33 (821.2)	21.26 (540)	31.15 (791.2)	1.18 (30)	14.28 (362.6)	12.76 (324)	21.70 (551.2)	23.67 (601.2)	2.16 (55)	4.38 (111.2)	2.02 (51.2)	1.18 (30)	1.18 (30)	1
125	2.02 (51.2)	3.79 (96.2)	1.96 (50)	19.26 (489.2)	2.44 (62)	32.33 (821.2)	21.26 (540)	31.15 (791.2)	1.18 (30)	14.28 (362.6)	12.76 (324)	21.70 (551.2)	23.67 (601.2)	2.16 (55)	4.38 (111.2)	2.02 (51.2)	1.18 (30)	1.18 (30)	1
150	2.02 (51.2)	3.79 (96.2)	1.96 (50)	19.26 (489.2)	2.44 (62)	34.69 (881.2)	23.62 (600)	33.51 (851.2)	1.18 (30)	14.28 (362.6)	12.76 (324)	21.70 (551.2)	23.67 (601.2)	2.16 (55)	4.38 (111.2)	2.02 (51.2)	1.18 (30)	1.18 (30)	1

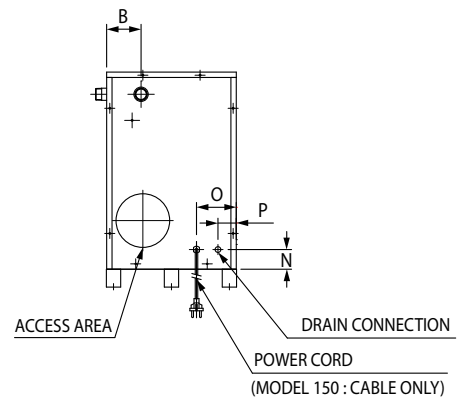
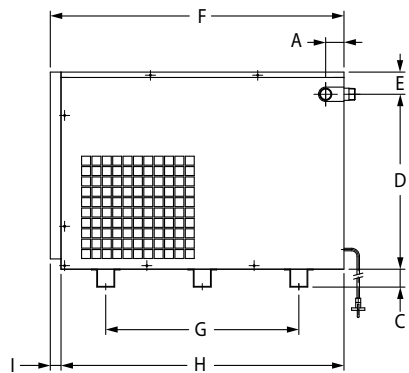
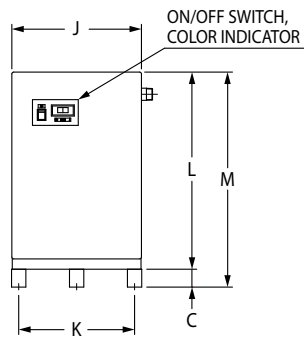
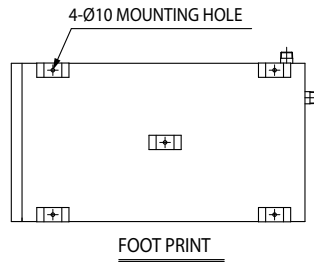
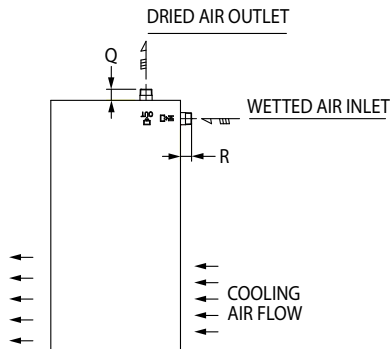

# GENERAL ARRANGEMENT DRAWINGS

Models HPRN200-2 through HPRN250-2

MODEL	DIMENSIONS, INCHES (MM)																		CONNECTIONS (INCHES, NPT)
	A	B	C	D	E	F	G	H	I	J	K	L	M	N	O	P	Q	R	
200	2.65 (67.2)	7.13 (181.2)	1.96 (50)	24.38 (619.2)	3.62 (92)	36.66 (931.2)	28.74 (730)	35.48 (901.2)	1.18 (30)	17.43 (442.6)	15.91 (404)	28.00 (711.2)	29.97 (761.2)	2.36 (60)	5.17 (131.2)	3.20 (81.2)	1.58 (40)	1.58 (40)	2
250	2.65 (67.2)	7.13 (181.2)	1.96 (50)	24.38 (619.2)	3.62 (92)	36.66 (931.2)	28.74 (730)	35.48 (901.2)	1.18 (30)	17.43 (442.6)	15.91 (404)	28.00 (711.2)	29.97 (761.2)	2.36 (60)	5.17 (131.2)	3.20 (81.2)	1.58 (40)	1.58 (40)	2

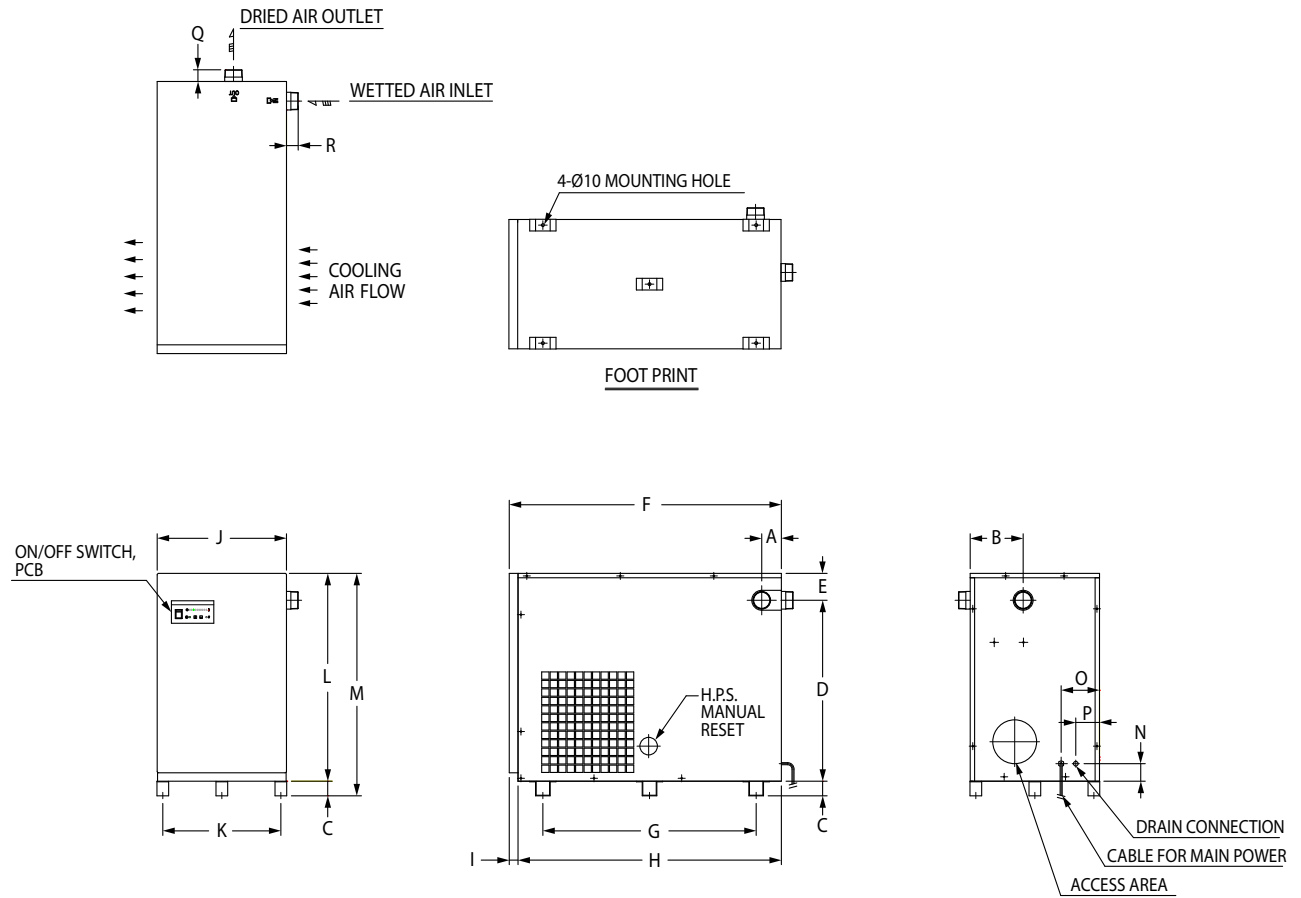

# GENERAL ARRANGEMENT DRAWINGS

Models HPRN300-2 through HPRN500

MODEL	DIMENSIONS, INCHES (MM)																		CONNECTIONS (INCHES, NPT)
	A	B	C	D	E	F	G	H	I	J	K	L	M	N	O	P	Q	R	
300	2.65 (67.2)	7.13 (181.2)	1.96 (50)	25.56 (649.2)	4.41 (112)	43.75 (1111.2)	35.83 (910)	42.57 (1081.2)	1.18 (30)	19.39 (492.6)	17.87 (454)	29.97 (761.2)	31.94 (811.2)	2.36 (60)	5.95 (151.2)	3.20 (81.2)	1.58 (40)	1.58 (30)	2
400	2.65 (67.2)	7.13 (181.2)	1.96 (50)	25.56 (649.2)	4.41 (112)	43.75 (1111.2)	35.83 (910)	42.57 (1081.2)	1.18 (30)	19.39 (492.6)	17.87 (454)	29.97 (761.2)	31.94 (811.2)	2.36 (60)	5.95 (151.2)	3.20 (81.2)	1.58 (40)	1.58 (30)	2
500	2.65 (67.2)	7.13 (181.2)	1.96 (50)	26.74 (679.2)	3.23 (82)	47.69 (1211.2)	38.19 (970)	46.50 (1181.2)	1.18 (30)	21.36 (542.6)	19.84 (504)	29.97 (761.2)	31.94 (811.2)	2.36 (60)	5.95 (151.2)	3.20 (81.2)	1.58 (40)	1.58 (40)	2

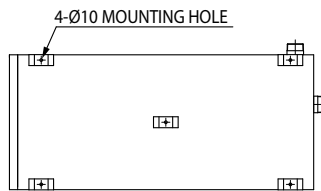
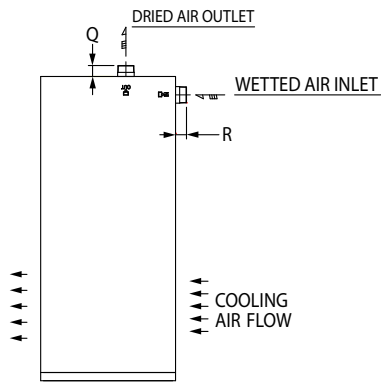

FOOT PRINT

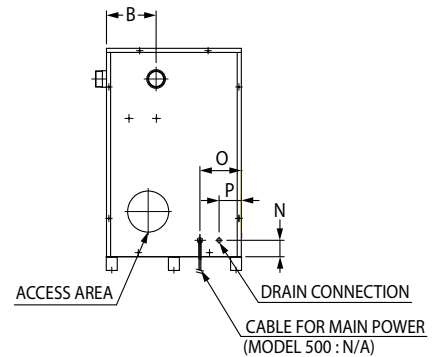
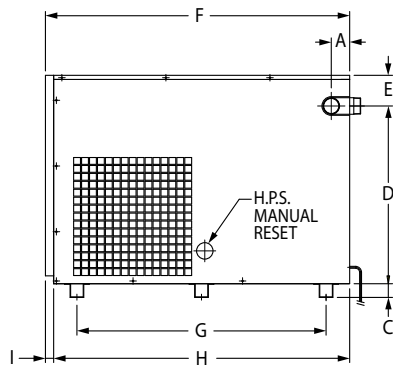
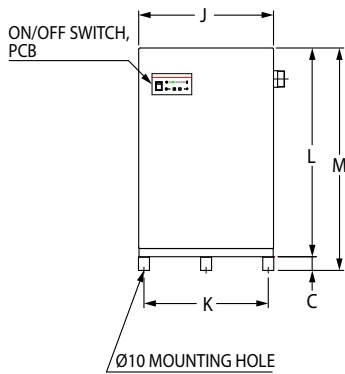

# ELECTRICAL SCHEMATICS

## Model HPRN75

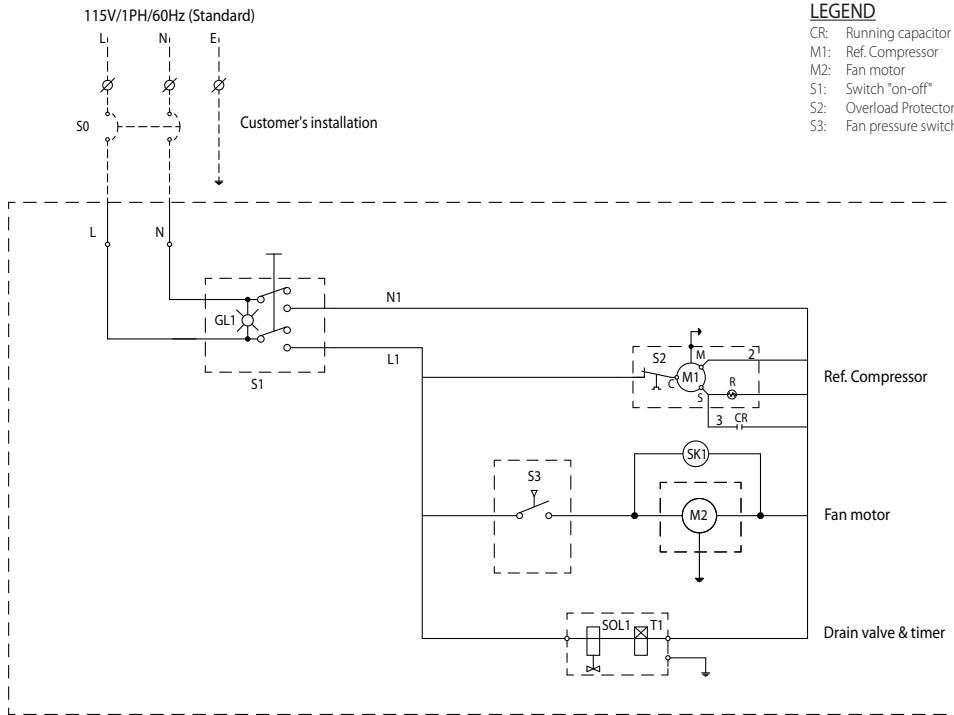

## Models HPRN100 through HPRN125

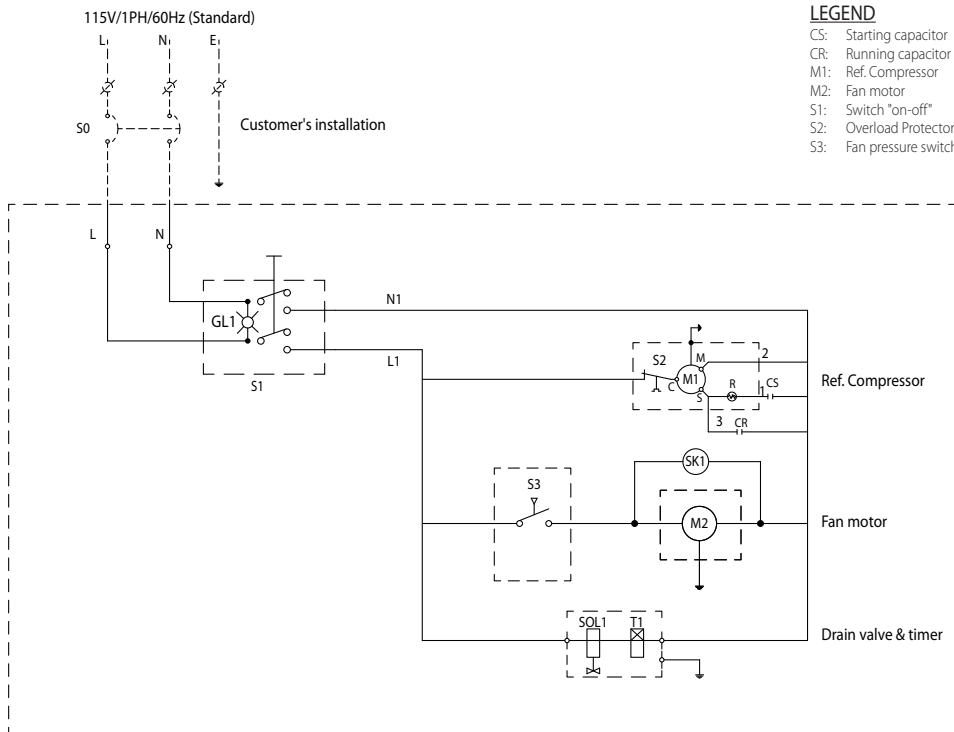

# ELECTRICAL SCHEMATICS

## Model HPRN150-2

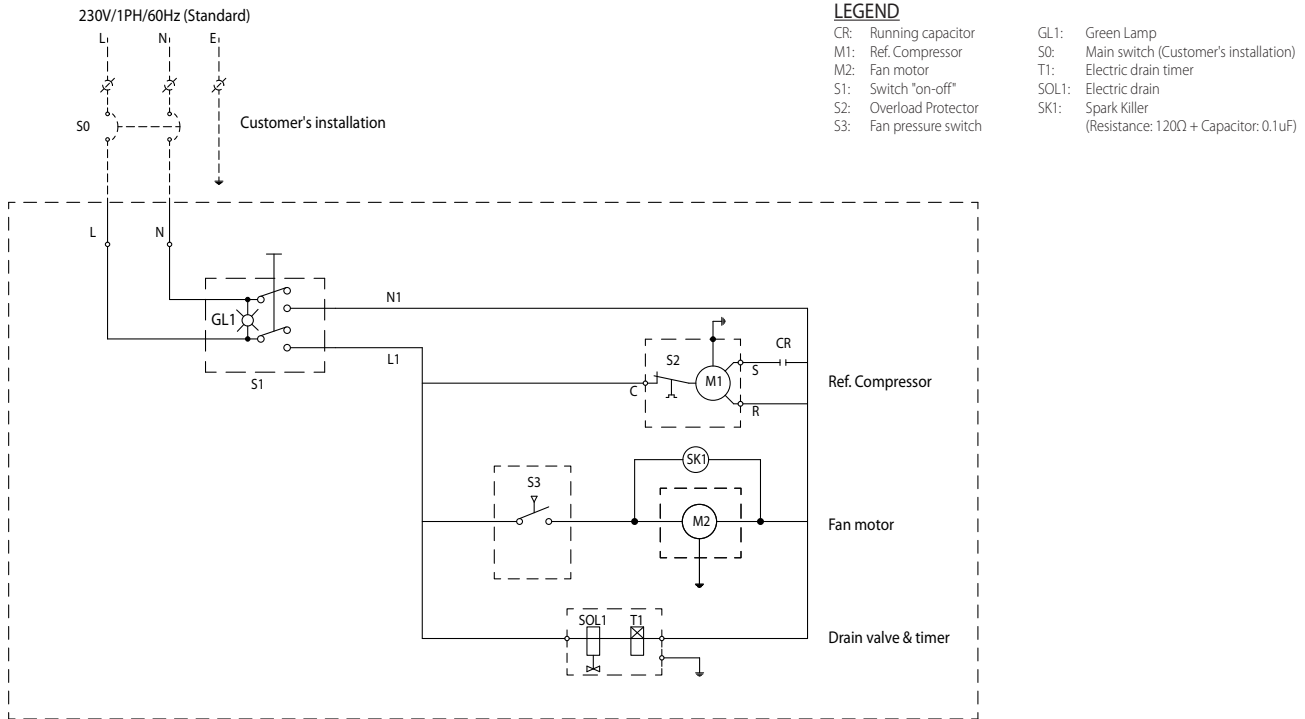

## Models HPRN200-2 through HPRN400-2

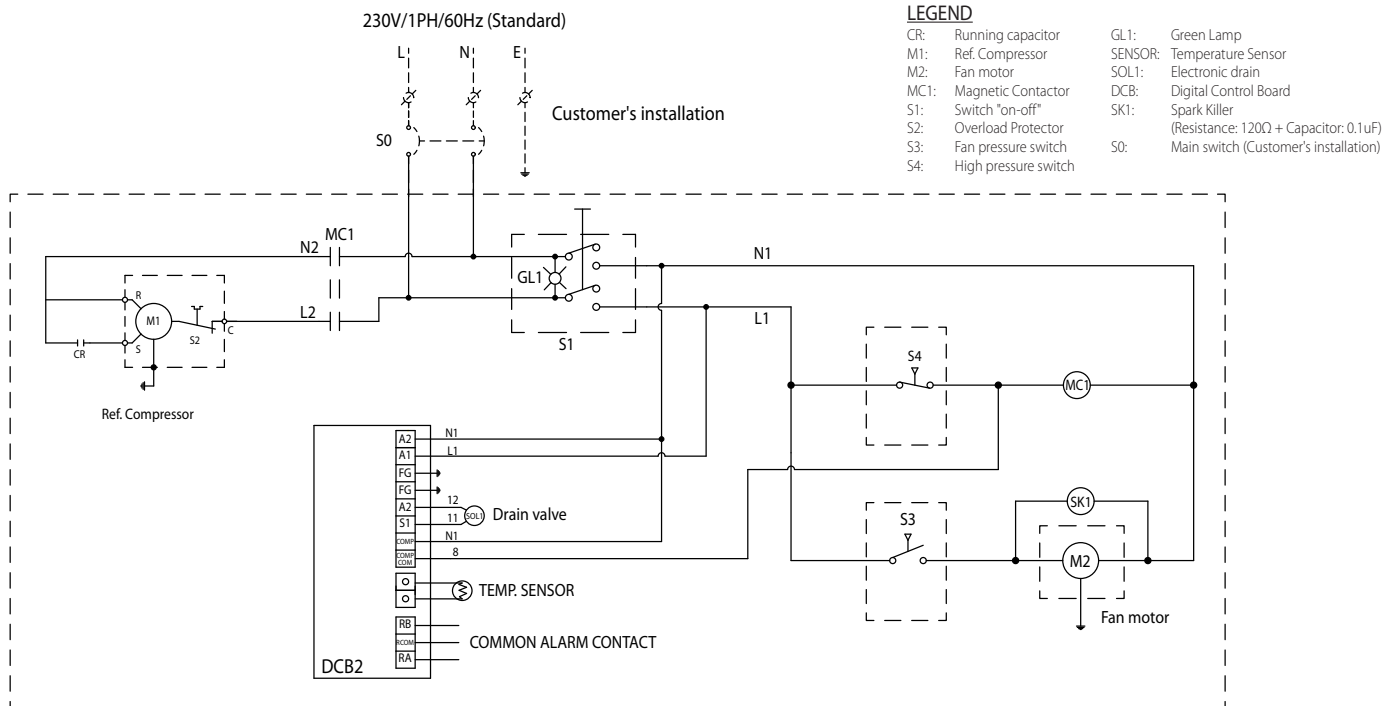



# ELECTRICAL SCHEMATICS

Model HPRN500

## LEGEND

CR:	Running capacitor	GL1:	Green Lamp
M1:	Ref. Compressor	SENSOR:	Temperature Sensor
M2:	Fan motor	SOL1:	Electronic drain
MC1:	Magnetic Contactor	DCB:	Digital Control Board
S1:	Switch "on-off"	SK1:	Spark Killer
S2:	Overload Protector		(Resistance: 120Ω + Capacitor: 0.1uF)
S3:	Fan pressure switch	S0:	Main switch (Customer's installation)
S4:	High pressure switch		

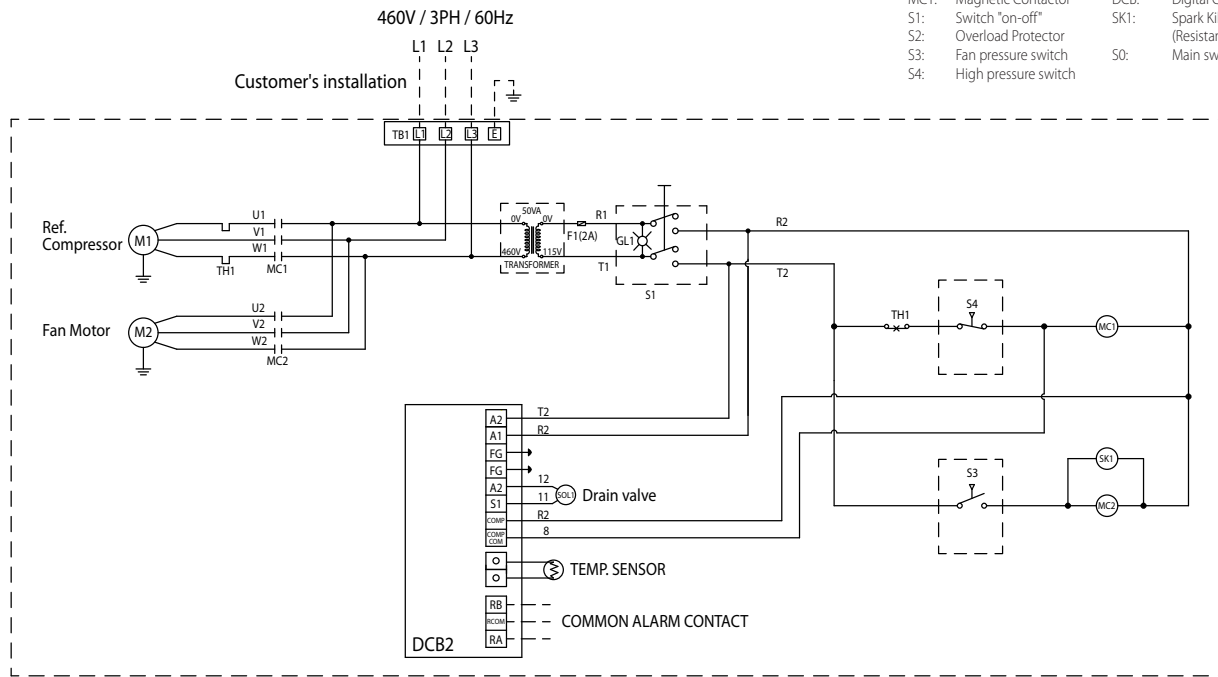

# AIR AND REFRIGERANT FLOW SCHEMATIC

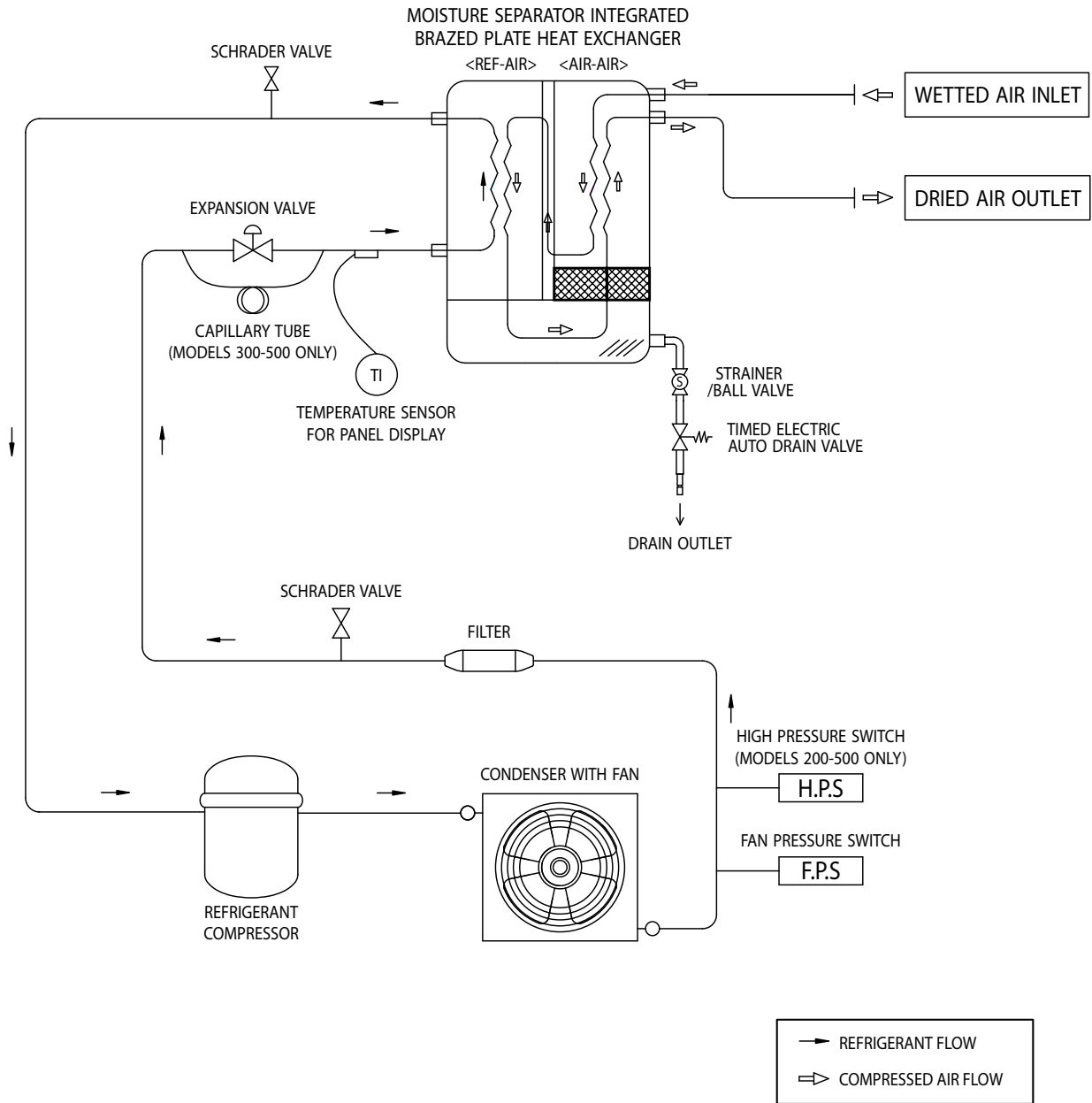

## REPLACEMENT PARTS

Item	Description	HPRN75	HPRN100	HPRN125	HPRN150-2
1	Refrigerant Compressor	3149274	3161249	3161249	7433660
2	Condenser (air-cooled)	7433666	7433667	7433668	7433668
3	Fan Blades	3041954	3041954	3041956	3041956
4	Fan Motor	3161257	3161257	3161243	7433673
5	Filter Dryer	3142596	3142596	3142596	7433676
6	Solenoid Valve Assembly	3161263	3161263	3161263	7427056
7	Solenoid Valve Timer	3161264	3161264	3161264	3161264
8	Solenoid Valve Strainer	3161265	3161265	3161265	3161265
9	DIN Socket	3161266	3161266	3161266	3161266
10	On/Off Switch with Running Lamp	3245021	3245021	3245021	3245021
11	Dew Point Indicator	3041493	3041493	3041493	3041493
12	Constant Pressure Valve	3161268	3161268	3161270	3041920
13	Heat Exchanger	7433679	7433680	7433681	7433682
14	Fan Pressure Switch	7433677	7433677	7433677	3161274
15	Run Capacitor	7433690	7433691	7433691	7433692
16	Start Capacitor	—	7433696	7433696	—

Item	Description	HPRN200-2	HPRN250-2	HPRN300-2	HPRN400-2	HPRN500
1	Refrigerant Compressor	7433661	7433662	7433663	7433664	3137014
2	Condenser	7433669	7433669	7433670	7433671	7433672
3	Fan Blades	3041957	3041957	3041958	3041958	3041958
4	Fan Motor	7433673	7433673	7433674	7433674	7433675
5	Filter Dryer	7433676	7433676	7433676	7433676	7433676
6	Solenoid Valve Assembly	3146977	3146977	3146977	3146977	3161248
7	Solenoid Valve Strainer	3146976	3146976	3146976	3146976	3146976
8	DIN Socket	3161267	3161267	3161267	3161267	3161267
9	Constant Pressure Valve	3041920	3041920	3041920	3154841	3154841
10	On/Off Switch with Running Lamp	3245021	3245021	3245021	3245021	3245021
11	High Pressure Switch	7433678	7433678	7433678	7433678	7433678
12	Fan Pressure Switch	3146975	3146975	3146975	3146975	3146975
13	Dryer System Monitor (DSM)	7433688	7433688	7433688	7433688	7433688
14	Heat Exchanger	7433683	7433684	7433685	7433686	7433687
15	Run Capacitor	7433693	7433693	7433694	7433695	—
16	Compressor Contactor	7433697	7433697	7433698	7433698	3242864
17	Fan Motor Contactor	—	—	—	—	3242863
18	Compressor Motor Starter Protector	—	—	—	—	7433700
19	Transformer	—	—	—	—	7433701
20	Fuse	—	—	—	—	7433699

Phone: 724-745-1555  
 FAX: 724-745-6040  
 Email: [hankison.americas.am@spxflow.com](mailto:hankison.americas.am@spxflow.com)  
 Web: [www.spxflow.com/hankison](http://www.spxflow.com/hankison)



## **WARRANTY**

The manufacturer warrants the product manufactured by it, when properly installed, operated, applied, and maintained in accordance with procedures and recommendations outlined in manufacturer's instruction manuals, to be free from defects in material or workmanship for a period as specified below, provided such defect is discovered and brought to the manufacturer's attention within the aforesaid warranty period.

The manufacturer will repair or replace any product or part determined to be defective by the manufacturer within the warranty period, provided such defect occurred in normal service and not as a result of misuse, abuse, neglect or accident. Normal maintenance items requiring routine replacement are not warranted. The warranty covers parts and labor for the warranty period unless otherwise specified. Repair or replacement shall be made at the factory or the installation site, at the sole option of the manufacturer. Any service performed on the product by anyone other than the manufacturer must first be authorized by the manufacturer.

Unauthorized service voids the warranty and any resulting charge or subsequent claim will not be paid. Products repaired or replaced under warranty shall be warranted for the unexpired portion of the warranty applying to the original product.

The foregoing is the exclusive remedy of any buyer of the manufacturer's product. The maximum damages liability of the manufacturer is the original purchase price of the product or part.

THE FOREGOING WARRANTY IS EXCLUSIVE AND IN LIEU OF ALL OTHER WARRANTIES, WHETHER WRITTEN, ORAL, OR STATUTORY, AND IS EXPRESSLY IN LIEU OF THE IMPLIED WARRANTY OF MERCHANTABILITY AND THE IMPLIED WARRANTY OF FITNESS FOR A PARTICULAR PURPOSE. THE MANUFACTURER SHALL NOT BE LIABLE FOR LOSS OR DAMAGE BY REASON OF STRICT LIABILITY IN TORT OR ITS NEGLIGENCE IN WHATEVER MANNER INCLUDING DESIGN, MANUFACTURE OR INSPECTION OF THE EQUIPMENT OR ITS FAILURE TO DISCOVER, REPORT, REPAIR, OR MODIFY LATENT DEFECTS INHERENT THEREIN.

THE MANUFACTURER, HIS REPRESENTATIVE OR DISTRIBUTOR SHALL NOT BE LIABLE FOR LOSS OF USE OF THE PRODUCT OR OTHER INCIDENTAL OR CONSEQUENTIAL COSTS, EXPENSES, OR DAMAGES INCURRED BY THE BUYER, WHETHER ARISING FROM BREACH OF WARRANTY, NEGLIGENCE OR STRICT LIABILITY IN TORT.

The manufacturer does not warrant any product, part, material, component, or accessory manufactured by others and sold or supplied in connection with the sale of manufacturer's products.

### **Warranty Period**

Parts and labor for two (2) years from the date of shipment from the factory; heat exchangers are covered (parts only) for an additional three (3) years (total of five (5)). On units that manufacturer requests be returned to the factory, a one time removal/reinstallation labor allowance as noted in the Service Warranty Policies and Procedures Handbook will apply. Freight to the factory from the installation site and to the installation site from the factory will be paid by the manufacturer; means of transportation to be specified by manufacturer.

**AUTHORIZATION FROM THE SERVICE DEPARTMENT IS NECESSARY BEFORE MATERIAL IS RETURNED TO THE FACTORY OR IN-WARRANTY REPAIRS ARE MADE.**

**SERVICE DEPARTMENT: (724) 746-1100**

# SPXFLOW<sup>®</sup>

## HPRN Series

Refrigerated Type Compressed Air Dryers

Models: HPRN75, HPRN100,  
HPRN125, HPRN150-2,  
HPRN200-2, HPRN250-2,  
HPRN300-2, HPRN400-2,  
HPRN500

**SPX FLOW, INC.**

4647 S.W. 40th Avenue

Ocala, Florida 34474-5788 U.S.A.

P: (724) 745-1555

F: (724) 745-6040

E: [hankison.americas@spxflow.com](mailto:hankison.americas@spxflow.com)

[www.spxflow.com/hankison](http://www.spxflow.com/hankison)

Improvements and research are continuous at SPX FLOW, Inc.

Specifications may change without notice.

ISSUED 05/2016 Form No.: 7433659 Revision: A

COPYRIGHT ©2016 SPX FLOW, Inc.