

NGF Series

Compressed Air Filters
Models F02 (grade) through F17 (grade)

FORM NO.: 3259479 REVISION: 02/2019

READ AND UNDERSTAND THIS MANUAL PRIOR TO OPERATING OR SERVICING THIS PRODUCT.



General Safety Information

1. Pressurized devices

⚠ WARNING

- Do not exceed maximum operating pressure indicated on serial number tag.
- Make certain filter is fully depressurized before servicing.

2. Breathing Air

- Air treated by this equipment may not be suitable for breathing without further purification. Refer to OSHA standard 1910.134 for breathing air requirements.

3. Flammable gases

⚠ WARNING

While the materials of construction are compatible with many flammable gases, the following application limitations must be considered:

- Housing materials are slightly porous. The product must be used in a well ventilated area in the absence of sparks or ignition sources. Do not use in Class 1, Division 1, Group D environments.
- The type of area - forced exhaust system used (i.e., high or low level) would be dependent on the gas involved.
- Each application (other than for air or inert gas) must be reviewed to minimize fire or explosion hazard.

Contents

Model Number Configuration.....	1
1.0 Installation	2
2.0 Operation.....	5
3.0 Maintenance.....	7
4.0 Dimensions and Weights	8
WARRANTY	9

Model Number Configuration



(1) Housing-Connection-Flow			
Model*	Connection	Flow @ 100 psig	Flow @ 6.9 bar
	in	scfm	nm ³ /h
02	1/4"	20	34
03	3/8"	35	59
04	1/2"	50	85
06	3/4"	75	127
07	3/4"	103	175
08	1.0"	157	267
10	1.5"	257	437
11	1.5"	360	612
12	2.0"	401	681
13	2.5"	584	993
14	2.5"	775	1317
15	2.5"	1030	1750
16	3.0"	1200	2039
17	3.0"	1500	2549

(2) Element Grade	
SF	Bulk Liquid Removal
PF	Particulate Removal
HF	Oil Removal
UF	High Efficiency Oil Removal
CF	Oil Vapor Removal

(3) Options	
T	Manual Drain
D	Internal Automatic Drain
P1	Differential Pressure Slide Indicator
G1	Differential Pressure Gauge
X	External Drain Adaptor (02-12)
Z1*	Electric Demand Drain (02-12)
Z2*	Electric Demand Drain (13-17)
W	External Mechanical Drain (13-17)

* Z1 and Z2 electric demand drain: Voltage 115 VAC 50-60 Hz

* BSP threads are available. Add B to the model number. Example F02B-SF-DP1

Example: F02-SF-DP1

Flow and Connection: 20 scfm (34 nm³/h); 1/4" NPT

Element Grade: SF - bulk liquid removal

Options: Internal automatic drain; differential pressure slide indicator

Grade Identification

Filter grade can be identified by the end cap color and model number printed on the bottom end cap.

Grade	Description	Type	End Cap Color
SF	Separator/filter	Liquid separator and 3 micron coalescer	Orange
PF	General purpose air line filter	1 micron coalescer	White
HF	High efficiency oil removal filter	High efficiency (99.99+%) coalescer	Green
UF	Maximum efficiency oil removal filter	Maximum efficiency (99.999+%) coalescer	Yellow
CF	Oil vapor removal filter	Activated carbon adsorber	Black

1.0 Installation

A. Where Used/Air Quality After Filtration

Grade	Where used	Solid particle removal (maximum size in microns)	Particle removal efficiency (at rated conditions)	Oil removal efficiency (at rated conditions)	Remaining oil content (mg/m ³)
SF	Separator - downstream of an aftercooler Point-of-use - where no aftercooler/separator is installed upstream	3	—	50%	5
PF	Prefilter <ul style="list-style-type: none"> Upstream to Grade HF & Grade UF - high efficiency oil removing filters Upstream of refrigerated dryers Afterfilter <ul style="list-style-type: none"> Downstream of heatless desiccant dryers Point-of-use - if aftercooler/separator is installed upstream	1	99.999+%	80%	2
HF	Prefilter <ul style="list-style-type: none"> Upstream of desiccant dryers Afterfilter <ul style="list-style-type: none"> Downstream of refrigerated dryer Point-of-use - if aftercooler/separator is installed upstream	0.01	99.999+%	99.9+%	0.01
UF	Prefilter <ul style="list-style-type: none"> Upstream of desiccant dryers Upstream of membrane dryers (use a PF Grade if heavy liquid loads are present) Afterfilter <ul style="list-style-type: none"> Downstream of refrigerated dryers 	0.01	99.9999+%	99.99+%	0.001
CF	Afterfilter to Grade HF & Grade UF for true oil free applications	0.01	99.999+%	—	< 0.004 vapor

B. Piping

- (1) Before installing, blow out pipe line to remove scale and other foreign matter.
- (2) The filter has DRYSEAL pipe threads; use pipe compound or Teflon™ tape sparingly to male threads only.
- (3) Mount so that inlet and outlet connections are horizontal (filter bowl vertical) to ensure proper liquid drainage.
- (4) Flow Direction - install so that the air flow is in the direction of arrows on the filter head.
- (5) Direct filter-to-filter (modular) connection - Filter heads may be joined without using a pipe nipple.
- (6) Isolation valves and by-pass piping - For ease of service, isolation and by-pass valves are desirable. In critical applications, two filters installed in parallel may be necessary to avoid interruption of air supply.

NOTE: All grades flow from inside to outside the element. Observe flow arrows on cap.

C. Wall Mount Bracket

- (1) Mount bracket as shown on wall or other structure using the holes provided on the back (hardware not included).
- (2) Set filter on bracket, resting inlet and outlet nozzles on the curved portions.
- (3) Insert two U bolts (supplied) as shown in Figure 1.1 through the holes in the bracket.
- (4) Add 4 nuts (supplied) to the U bolts and tighten until snug.

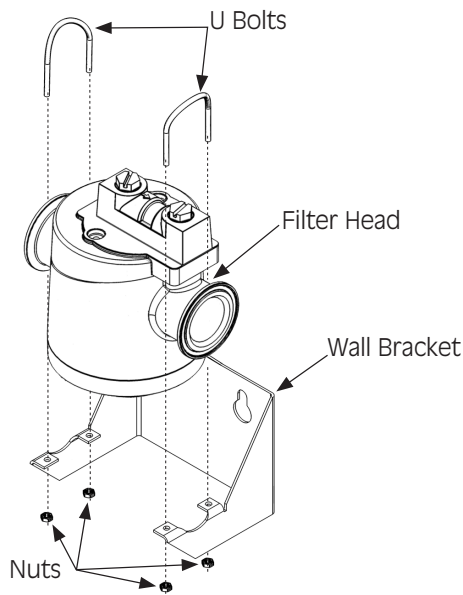

Figure 1.1

D. Differential Pressure Gauge Mounting to Filter Head (Figure 1.2)

- (1) Make certain O-rings are in place on the bottom of the gauge body.
- (2) Connect the low pressure transmission bolt (bolt next to the red band on the indicator) to the port at the filter outlet (downstream side of filter).
- (3) Connect the high pressure transmission bolt (bolt next to the Green band on the indicator) to the port at the filter inlet (upstream side of the filter).
- (4) Use a coin or a flat head screwdriver to tighten/loosen bolts. The tip width if the screwdriver should be at least 3/8 inch (9.5 mm). Torque bolts to 25 ± 5 inch-oz. **DO NOT OVER TIGHTEN**

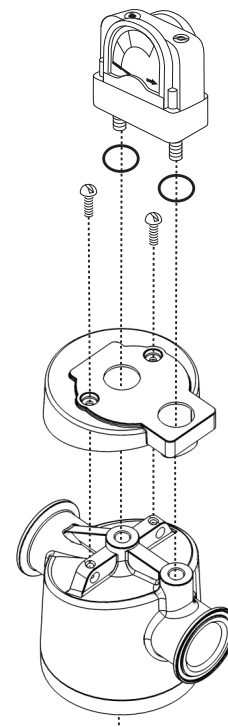

Figure 1.2

E. Drain Provisions

- (1) Internal Automatic Drains – Drain Line
The bottoms of internal automatic drains are provided with 1/8" (inside threads) for connection of a drain line if desired.
- (2) External Automatic Drains –
External automatic drains may be added as follows:
 - (a) Models F02 through F12 – remove internal drain and install adaptor (available from factory). Adaptor outlet connection is 1/8" (inside threads).

⚠ WARNING Discharge is at system pressure, anchor drain line.

- (b) Models F13 through F17 – remove plug from external drain adaptor fitting at bottom of bowl. The 1/2" (male threads) port is available for external drain connection. Filter may be drained with an electrical demand drain, or mechanically.

⚠ WARNING Do not attempt to remove drain plug if unit is pressurized.

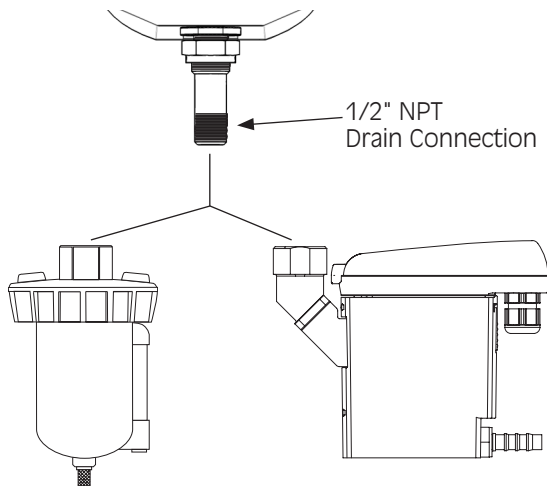

Figure 1.3

F. Connector Clamps

- (1) Align the clamp gasket with the outlet flange on Filter #1 making sure its is centered on the flange groove.
- (2) Align the inlet flange from Filter #2 with the clamp gasket and Filter #1.
- (3) Open the clamp assembly and center it between the two filters.
- (4) Close the clamp assembly and tighten the wing nut compressing the gasket between the two filters.

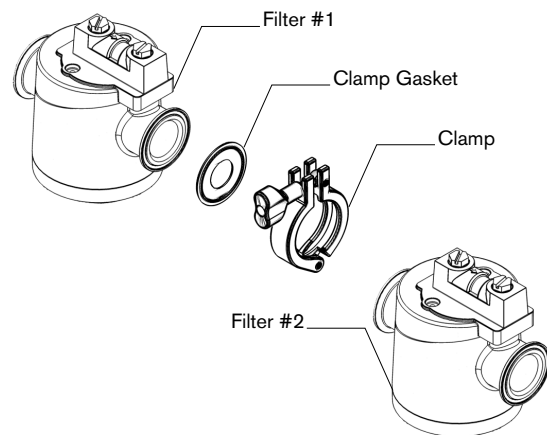

Figure 1.4

2.0 Operation

⚠ WARNING Do not operate filter at pressures in excess of Maximum Working Pressure indicated on Serial Number Tag.

NOTE: Maximum Operating Temperature - 150°F (66°C). Liquid filtration above 120°F (49°C) is not recommended since there is typically oil present in a vapor state which passes through the filter and condenses downstream.

NOTE: Grade CF - If operated above 100°F (38°C) may experience less than 1000 hours of life because of greater oil vapor content.

A. Liquid Draining - Grades SF, PF, HF, and UF

NOTE: Collected liquids must be removed to ensure proper operation.

NOTE: Depressurize slowly, to avoid filter element damage.

1. Manual Drain - Turn to the right (clockwise) to open and to the left (counterclockwise) to close.
2. Automatic Drain - Liquids will automatically discharge when sufficient accumulation occurs.
 - a) Internally Mounted Auto Drains - These drains may be manually drained by turning to the right (clockwise) to open and to the left (counterclockwise) to close.

NOTE: Manually drain internal auto drains daily to verify drain function.

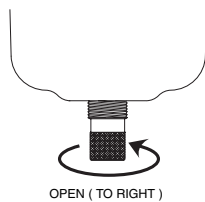

Figure 2.1

B. Operational Checkpoints

All Grades

Check flow, pressure, and temperature to make certain filter is being operated within design conditions.

Grades SF, PF, HF, and UF

Check pressure drop across the filter

1. Pressure differential in excess of 4.3 psid (0.3 bar) - pressure indicator in red area - indicates that the filter element should be replaced. Reference page 8, Figure 3.3 for gauge scale detail.

NOTE: Element should be changed annually or when indicator changes to red, whichever occurs first.

NOTE: Pressure drop should never exceed 50 psi (3.4 bar).

2. Check for sudden reduction in pressure drop. This might indicate:
 - a. Possible leak across element o-ring seal.
 - b. Leak through the element due to physical damage.

Grades SF, PF, HF, and UF

1. Check to see that filter is installed level to insure proper drainage.
2. Check that manual drains are drained periodically or that automatic drains are functioning.

Grade CF (Adsorber filter)

1. Check for an oil like smell by opening the manual valve. If an oily smell exists, the following should be checked:
 - a. Filter element adsorption capacity exhausted.
 - b. Leak across element o-ring seal.
 - c. Leak through element due to physical damage.
 - d. Presence of liquids because of lack of or failure of prefilters.
 - e. Flow, pressure and temperatures outside design conditions.
 - f. Presence of gaseous impurities which cannot be adsorbed.

⚠ CAUTION Methane, carbon monoxide, carbon dioxide and various inorganic gases cannot be removed by an activated carbon filter.

C. Flow Capacity

Maximum air flow for the various filters at 100 psig (6.9 bar) is indicated in Table 1. To determine maximum air flows at inlet pressures other than 100 psig (6.9 bar), multiply flow from Table 1 by air flow correction factor from Table 2 that corresponds to the minimum operating pressure at the inlet of the filter.

NOTE: Filters should not be selected by pipe size. Select using flow rate and operating pressure only.

Table 1 - Maximum Flow @100 psig [6.9 bar]

Housing	scfm [nm ³ /h]
F02	20 [34]
F03	35 [59]
F04	50 [85]
F06	75 [127]
F07	103 [175]
F08	157 [267]
F10	257 [437]
F11	360 [612]
F12	401 [681]
F13	584 [993]
F14	775 [1317]
F15	1030 [1750]
F16	1200 [2039]
F17	1500 [2549]

Table 2 - Air Flow Correction Factor

Inlet Pressure	psig	20	30	40	60	80	100	120	150	200	250
	bar	1.4	2.1	2.8	4.1	5.5	6.9	8.3	10.3	13.8	17.2
Correction Factor		0.30	0.39	0.48	0.65	0.83	1.00	1.17	1.44	1.87	2.31

3.0 Maintenance

A. When to Replace Filter Element

NOTE: Grades SF, PF, UF, HF, CF - complete element is replaced;

1. Grades SF, PF, UF, HF
 - a. Operating pressure drop: As filter becomes liquid loaded (wetted), pressure drop will increase. Further pressure drop occurs as element loads with solid particles.

FOR MAXIMUM FILTRATION EFFICIENCY, REPLACE ELEMENT WHEN PRESSURE DROP REACHES 4.3 PSID (0.3 BAR) (INDICATOR IN RED AREA) OR ANNUALLY, WHICHEVER OCCURS FIRST.

NOTE: Pressure drop may temporarily increase when flow is resumed after flow stoppage. Pressure drop should return to normal within one hour.

2. Grade CF - Oil vapor removal filter
 - a. Adsorption capacity - 1000 hours at rated capacity. Element life is exhausted when odor can be detected downstream of the filter.

B. Procedure for Element Replacement

WARNING: THIS FILTER IS A PRESSURE CONTAINING DEVICE. DEPRESSURIZE BEFORE SERVICING. If filter has not been depressurized before disassembly, an audible alarm will sound when the bowl begins to be removed from the head. If this occurs, stop disassembly, isolate and completely depressurize filter before proceeding.

1. Isolate filter (close inlet and outlet valves if installed) or shut off air supply.
2. Depressurize filter by slowly opening manual drain valve.
3. Remove bowl.
 - a. Unscrew the bowl from the filter head using hand, strap wrench or C spanner. Pull bowl straight down.
4. Clean filter bowl.
5. Replace element.
 - a. Replacing complete element.
 - 1) Pull off old element and discard.
 - 2) Make certain that the old and new element have the same part number and the end caps are the same color.
 - 3) Wipe the wall inside the filter head to remove any dirt.
 - 4) Lubricate the new element o-ring on the element top cap.

- 5) Align the slot in the element top cap with the projection inside the filter head.

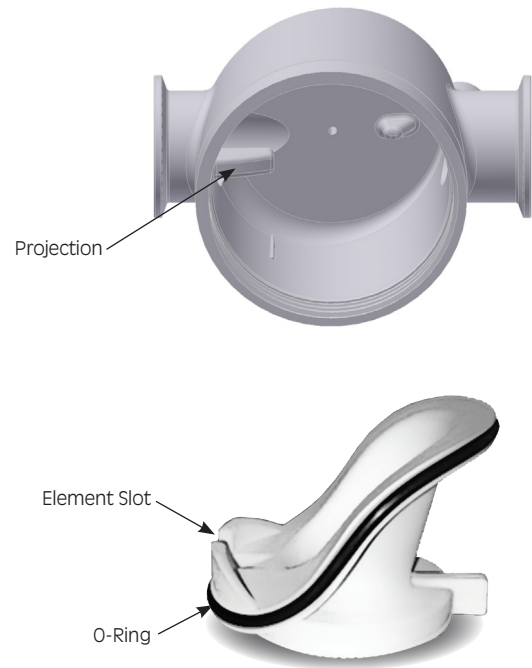

Figure 3.1

- 6) Insert the element into the head making sure the element slot and the projection inside the filter head remain aligned.

NOTE: Handle all elements by bottom end cap only.

6. Replace housing o-ring (located at the top of the filter bowl) if needed. Make certain o-ring is generously lubricated (Use lubricant provided).
7. Reassemble bowl to head.

NOTE: Threaded bowl to head connection, generously lubricate threads with a high grade/temperature lubricant 150°F (66°C). (Use lubricant provided)

C. Auto Drain Mechanism

It is recommended that drain mechanism be replaced annually.

4.0 Dimensions and Weights

Model Number	Max. Flow @ 100 psig (6.9 bar)		Connections NPT	Dimensions								Weight	
	scfm	nm ³ /h		'A' Width		'B' Height		'C' Height		'D' Bowl Clearance		lbs	kg
				in	mm	in	mm	in	mm	in	mm		
F02	20	34	1/4"	4.5	114	8.1	206	6.8	173	4.0	102	1.8	0.8
F03	35	59	3/8"	4.5	114	8.1	206	6.8	173	4.0	102	1.8	0.8
F04	50	85	1/2"	4.5	114	9.9	252	8.5	216	4.0	102	1.9	0.9
F06	75	127	3/4"	5.2	132	10.3	262	8.7	221	5.0	127	3.1	1.4
F07	103	175	3/4"	5.2	132	10.3	262	8.7	221	5.0	127	3.1	1.4
F08	157	267	1.0"	5.2	132	12.8	325	11.7	297	5.0	127	3.5	1.6
F10	257	437	1.5"	7.9	201	13.3	338	10.9	277	7.0	178	8.4	3.8
F11	360	612	1.5"	7.9	201	17.1	434	14.7	373	7.0	178	9.9	4.5
F12	401	681	2.0"	7.9	201	22.3	566	19.9	506	7.0	178	11.6	5.3
F13	584	993	2.5"	9.1	231	24.9	633	21.7	551	8.0	203	18.6	8.4
F14	775	1,317	2.5"	9.1	231	24.9	633	21.7	551	8.0	203	18.6	8.4
F15	1,030	1,750	2.5"	9.1	231	32.2	818	28.9	734	8.0	203	27.7	12.6
F16	1,200	2,039	3.0"	9.1	231	32.2	818	28.9	734	8.0	203	27.7	12.6
F17	1,500	2,549	3.0"	9.1	231	42.7	1,085	39.4	1,001	8.0	203	41.3	18.7

NOTE: Dimensions and Weights are for reference only. Request certified drawings for construction purposes.

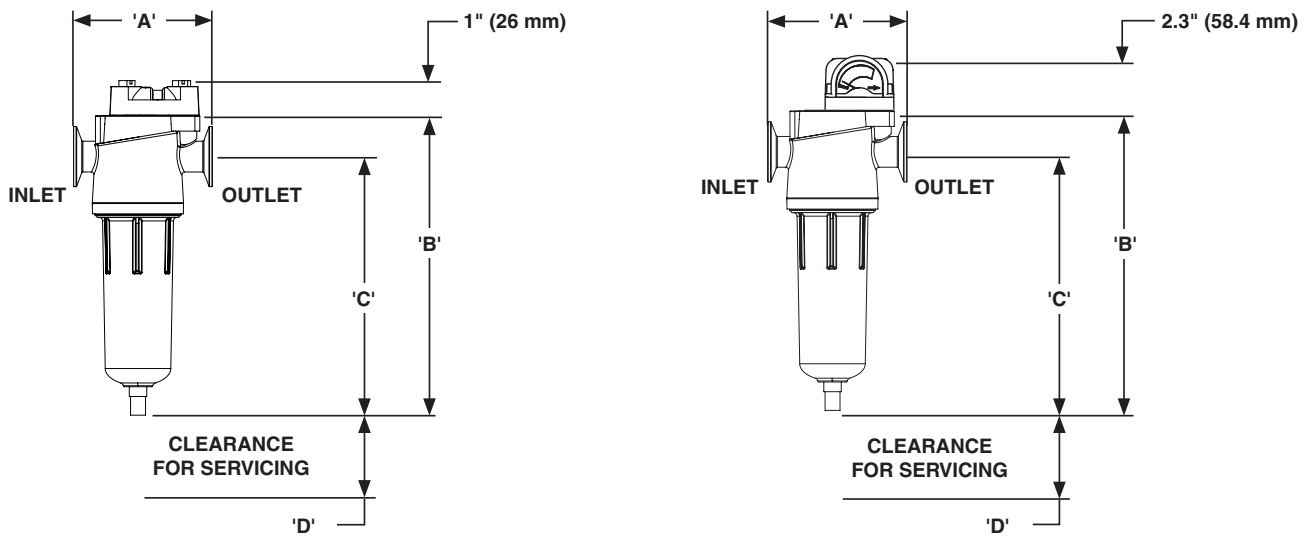

Figure 3.2

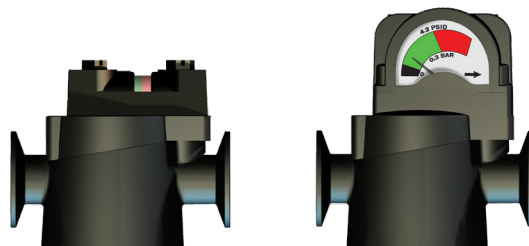

Figure 3.3

Differential pressure gauge and slide indicator – change element when indication is in the red zone.

WARRANTY

The manufacturer warrants the product it manufactures, when properly installed, operated, applied, and maintained in accordance with procedures and recommendations outlined in manufacturer's instruction manuals, will be free from defects in material or workmanship for a period as specified below, provided such defect is discovered and brought to the manufacturer's attention within the aforesaid warranty period.

The manufacturer will repair or replace any product or part determined to be defective by the manufacturer within the warranty period, provided such defect occurred in normal service and not as a result of misuse, abuse, neglect or accident. Normal maintenance items requiring routine replacement are not warranted. The warranty covers parts and labor for the warranty period unless otherwise specified. Repair or replacement shall be made at the factory or the installation site, at the sole discretion of the manufacturer. Although not required for warranty consideration, it is recommended that the manufacture be contacted prior to doing any warranty related service work. This action will provide guidance and instruction on the repair often times authorization to perform the work. NOTE: The manufacture reserves the right to repair, replace in the case of warranty approval or reject the warranty claim once submitted.

Unauthorized service and use of unauthorized or pirated parts voids the warranty and any resulting charges or subsequent claim will not be paid. Products repaired or replaced under warranty shall be warranted for the unexpired portion of the warranty applying to the original product.

The foregoing is the exclusive remedy of any buyer of the manufacturer's product. The maximum damages liability of the manufacturer is the original purchase price of the product or part.

THE FOREGOING WARRANTY IS EXCLUSIVE AND IN LIEU OF ALL OTHER WARRANTIES, WHETHER WRITTEN, ORAL, OR STATUTORY, AND IS EXPRESSLY IN LIEU OF THE IMPLIED WARRANTY OF MERCHANTABILITY AND THE IMPLIED WARRANTY OF FITNESS FOR A PARTICULAR PURPOSE. THE MANUFACTURER SHALL NOT BE LIABLE FOR LOSS OR DAMAGE BY REASON OF STRICT LIABILITY IN TORT OR ITS NEGLIGENCE IN WHATEVER MANNER INCLUDING DESIGN, MANUFACTURE OR INSPECTION OF THE EQUIPMENT OR ITS FAILURE TO DISCOVER, REPORT, REPAIR, OR MODIFY LATENT DEFECTS INHERENT THEREIN. THE MANUFACTURER, HIS REPRESENTATIVE OR DISTRIBUTOR SHALL NOT BE LIABLE FOR LOSS OF USE OF THE PRODUCT OR OTHER INCIDENTAL OR CONSEQUENTIAL COSTS, EXPENSES, OR DAMAGES INCURRED BY THE BUYER, WHETHER ARISING FROM BREACH OF WARRANTY, NEGLIGENCE OR STRICT LIABILITY IN TORT.

Please note that the manufacturer's warranty for this product is intended to cover manufacturing defects and therefore does not cover consumable components (desiccants, filter elements, soft goods, standard maintenance kit wear items, etc.) or components that require periodic user adjustment (expansion valve, hot gas bypass valve or cooling water regulating valve) or calibration (dew point elements/sensors, gauge calibration, etc.)

Warranty Period

One (1) year parts and labor from the date of shipment from the manufacturer or the manufacturer's authorized distributor (not to exceed eighteen (18) months from the date of shipment from the factory, whichever occurs first).

**AUTHORIZATION FROM THE SERVICE DEPARTMENT IS NECESSARY BEFORE
MATERIAL IS RETURNED TO THE FACTORY OR IN-WARRANTY REPAIRS ARE MADE.**

SERVICE DEPARTMENT: (724) 746-1100

NGF SERIES

Compressed Air Filters

Models F02 (grade) through F17 (grade)

SPXFLOW[®]

SPX FLOW

4647 S.W. 40th Avenue

Ocala, Florida 34474-5788 U.S.A.

P: (724) 745-1555

F: (724) 745-6040

E: hankison.americas@spxflow.com

www.spxflow.com/hankison

Improvements and research are continuous at SPX FLOW, Inc.

Specifications may change without notice.

ISSUED 02/2019 Form No.: 3259479 Revision: D

COPYRIGHT ©2019 SPX FLOW, Inc.