

DHW Series

Pressure Swing Desiccant Compressed Air Dryer
Models 7 through 50 scfm

FORM NO.: 3215738 REVISION: 02/2019

READ AND UNDERSTAND THIS MANUAL PRIOR TO OPERATING OR SERVICING THIS PRODUCT.



Contents

1.0 GENERAL INFORMATION	2
2.0 DESCRIPTION	3
3.0 INSTALLATION	4
4.0 OPERATION	7
5.0 MAINTENANCE.....	9
6.0 REPAIR PARTS	10
WARRANTY	11

IMPORTANT READ PRIOR TO STARTING THIS EQUIPMENT

UNPACKING

This shipment has been thoroughly checked, packed and inspected before leaving our plant. It was received in good condition by the carrier and was so acknowledged.

- 1) Check for Visible Loss or Damage. If this shipment shows evidence of loss or damage at time of delivery to you, insist that a notation of this loss or damage be made on the delivery receipt by the carrier's agent.
- 2) Check for Concealed Loss or Damage. When a shipment has been delivered to you in apparent good order, but concealed damage is found upon unpacking, notify the carrier immediately and insist on his agent inspecting the shipment. Fifteen days from receipt of shipment is the maximum time limit for requesting such inspection. Concealed damage claims are not our responsibility as our terms are F.O.B. point of shipment.

1.0 GENERAL INFORMATION

CAUTION

- A. **Pressurized devices-**
This equipment is a pressure containing device.
 - Do not exceed maximum operating pressure as shown on equipment serial number tag.
 - Make sure equipment is depressurized before working on or disassembling it for servicing.
- B. **Electrical-**
This equipment requires electricity to operate.
 - Install equipment in compliance with national and local electrical codes.
- C. **Breathing air-**
 - Air treated by this equipment may not be suitable for breathing without further purification. Refer to OSHA standard 1910.134 or other applicable standards for the requirements for breathing quality air.

2.0 DESCRIPTION

2.1 Function

Dual tower regenerative desiccant dryers are utilized to dry compressed air to dew points below the freezing point of water or reduce the moisture content to low levels for use in critical process applications.

Air is dried by using two identical towers, each containing a desiccant bed. While one tower is on-stream drying the compressed air, the other tower is off-stream being regenerated (reactivated, i.e., dried out).

Desiccant dryers lower the dew point by adsorbing most of the water vapor present onto the surface of the desiccant. Adsorption occurs until an equilibrium is reached between the partial pressure of the water vapor in the air and that on the surface of the desiccant.

Desiccant can then be regenerated by desorbing the water collected on its surface. Regeneration occurs by expanding a portion of the dried air to atmospheric pressure. This very dry air (called purge air) causes the moisture to desorb from the desiccant and then carries the desorbed water out of the dryer.

2.2 Operation

Compressed air enters the dryer and is directed to TOWER 1 through valve (A) and then exits the dryer through shuttle valve (B). A portion of the dried air is throttled to near atmospheric pressure by means of an orifice (C). This extremely dry, low pressure air flows through and regenerates the desiccant in TOWER 2 and is then exhausted through purge/repressurization valve (D) and exhaust muffler (E) to atmosphere.

After a set time, the automatic solid state timer closes purge/repressurization valve (D) allowing TOWER 2 to repressurize slowly.

At the end of 2 minutes, valve (F) opens and Tower 1 depressurizes. The main air flow is now dried by Tower 2 while Tower 1 is regenerated.

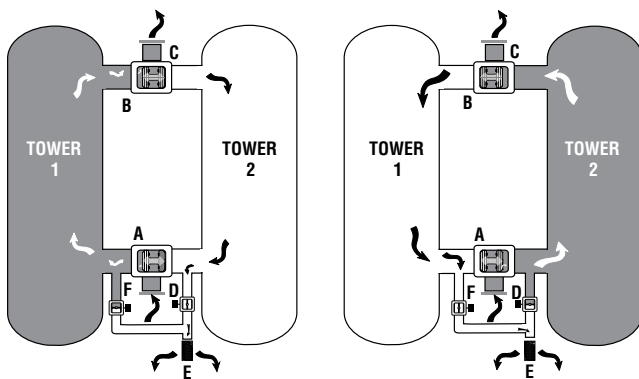

Figure 1 – Flow Schematic
Models 7 through 50

2.3 Air By-Pass Assembly

An optional air by-pass assembly is available for all models. When ordered with the dryer, the by-pass assembly is factory installed inside the dryer cabinet. Make sure the by-pass assembly is in the desired mode: "Dry" (compressed air flow through the dryer) or "By-pass" (compressed air by-passes the dryer).

2.3.1 Models 7 and 13

The by-pass assembly includes a by-pass valve with a manually operated spool. One end of the spool is marked "Push to Dry" and the other end is marked "Push to Bypass". To select the desired mode, remove the locking pin, push and fully depress the appropriately marked end of the spool, and install the locking pin in the opposite end.

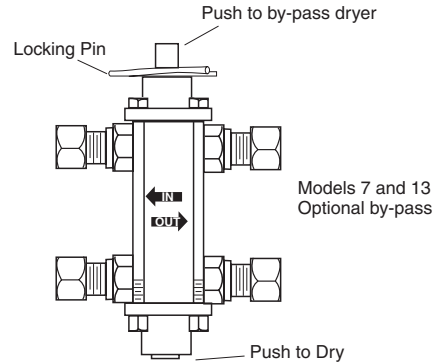
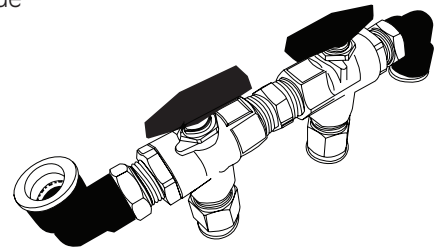

Figure 2a – Air Bypass Assembly
Models 7 and 13

2.3.2 Models 20, 25, 30, 35, and 50

The by-pass assembly includes two manually operated three-way valves. To select "Dry" mode, rotate the valve handles so that the arrows point away from each other. To select "By-Pass" mode, rotate the valve handles so that the arrows point toward each other.

Dry Mode



By-Pass Mode

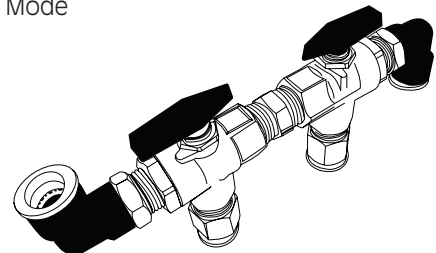

Figure 2b – Air Bypass Assembly
Models 20 through 50

3.0 INSTALLATION

3.1 Dimensions, Connections, Weight

MODEL NUMBER	DIMENSIONS in (mm)										CONNECTIONS		WEIGHT lb (kg)
	A	B	C	D	E	F	H	J	K	M	INLET	OUTLET	
7	31.09 (790)	17.52 (445)	1.15 (29)	15.23 (387)	6.69 (170)	3.74 (95)	30.5 (775)	3.74 (95)	5.31 (135)	27.5 (699)	1/2" NPT (F)	1/2" NPT (F)	55 (25)
13	31.09 (790)	17.52 (445)	1.15 (29)	15.23 (387)	6.69 (170)	3.74 (95)	30.5 (775)	3.74 (95)	5.31 (135)	27.5 (699)	1/2" NPT (F)	1/2" NPT (F)	60 (27)
20	31.09 (790)	17.52 (445)	1.15 (29)	15.23 (387)	6.69 (170)	3.74 (95)	30.5 (775)	3.74 (95)	5.31 (135)	27.5 (699)	1/2" NPT (F)	1/2" NPT (F)	71 (32)
25	37.94 (964)	24.37 (619)	1.68 (43)	21 (533)	8.54 (217)	6.73 (171)	31.6 (803)	4.25 (108)	6.22 (158)	27.5 (699)	1/2" NPT (F)	1/2" NPT (F)	93 (42)
30	37.94 (964)	24.37 (619)	1.68 (43)	21 (533)	8.54 (217)	6.73 (171)	31.6 (803)	4.25 (108)	6.22 (158)	27.5 (699)	1/2" NPT (F)	1/2" NPT (F)	93 (42)
35	37.94 (964)	24.37 (619)	1.68 (43)	21 (533)	8.54 (217)	6.73 (171)	31.6 (803)	4.25 (108)	6.22 (158)	27.5 (699)	1/2" NPT (F)	1/2" NPT (F)	99 (45)
50	37.94 (964)	24.37 (619)	1.68 (43)	21 (533)	8.54 (217)	6.73 (171)	43.3 (1100)	4.25 (108)	6.22 (158)	39.3 (998)	1/2" NPT (F)	1/2" NPT (F)	132 (60)

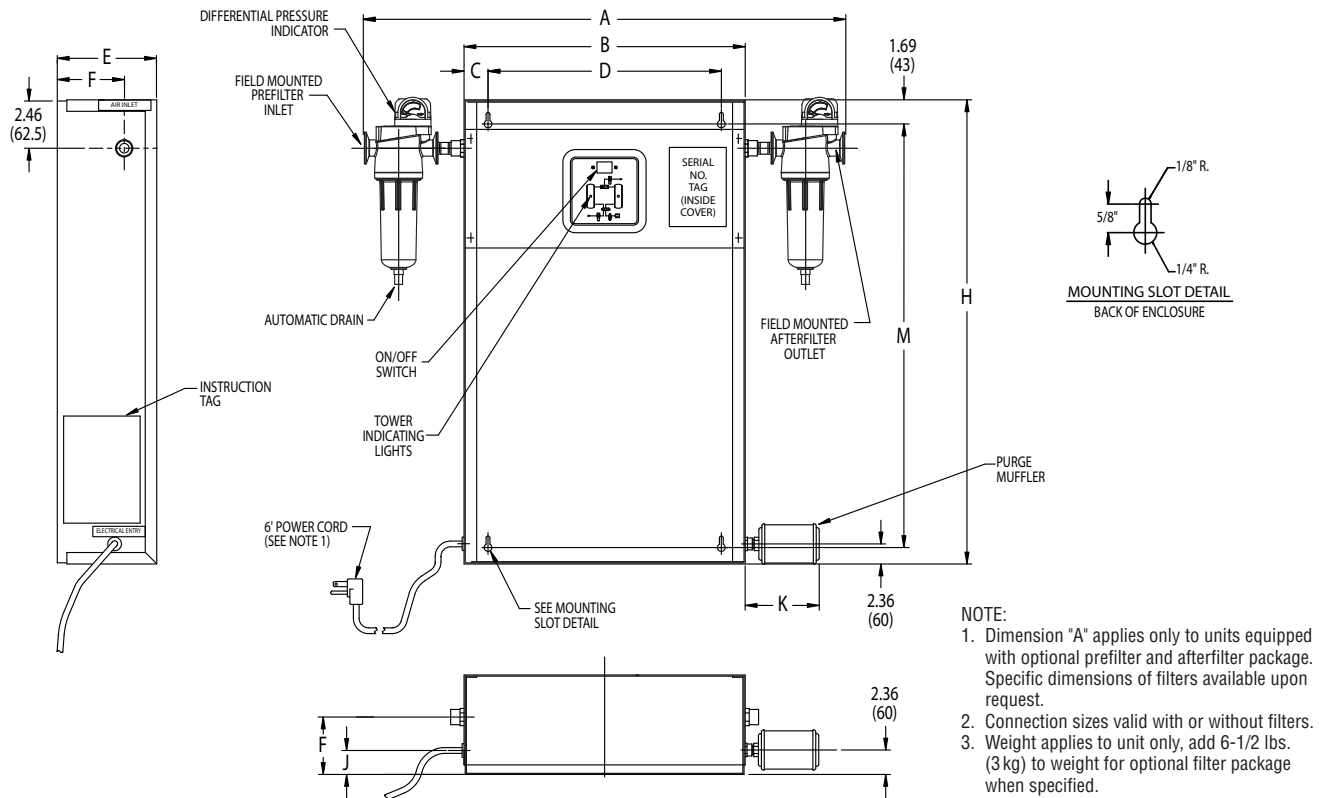

Figure 3 Dimensional Drawing

Maximum Operating Pressure:
150 psig, 10.5 kgf/cm²

Maximum Operating Temperature:
120°F, 49°C

3.2 Electrical Specifications

MODEL	WATTS
7	27.5
13	27.5
20	27.5
25	31.8
30	31.8
35	33.0
50	17.0

LEGEND

All Models	SOL 1	Left Purge Valve
	SOL 2	Right Purge Valve
All Models	SW1	On/Off Switch

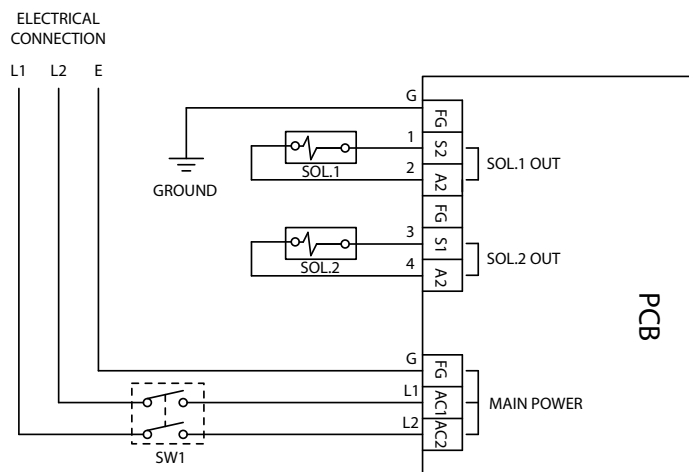
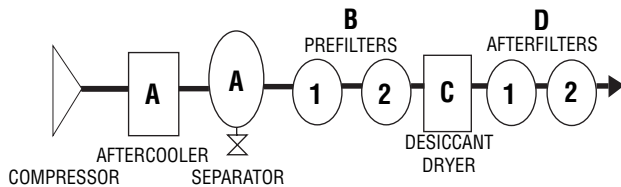

Figure 4 Electrical Hook-up

3.3 Dryer Location in a Compressed Air System



NOTE: Air Compressor should be adequately sized to handle air system demands as well as purge loss. Failure to take this into account could result in overloading air compressors and/or insufficient air supply downstream.

NOTE: It is desirable to install dryer where compressed air is at the lowest possible temperature (downstream of aftercoolers) and the highest possible pressure (upstream of pressure reducing valves) without exceeding the maximum working pressure.

A. **Aftercooler/Separator** - Compressed air entering dryer must be cooled to at least 120°F (49°C). Use aftercooler and separator if higher temperatures are present.

NOTE: Installation of a refrigerated dryer ahead of a pressure-swing desiccant dryer does not increase desiccant dryer capacity or reduce purge flow requirements. However, if necessary, a cooling unit can be installed ahead of the desiccant dryer to reduce the inlet air temperature to the dryer, producing a correspondingly lower outlet dew point.

B. **Prefilters** - Adequate filtration is required upstream of the dryer in order to protect the desiccant bed from contamination. The following filters are recommended:

1. **Air Line Filter** - On compressed air systems utilizing non-lubricated (oil-free) air compressors, use to protect desiccant bed from solid and liquid contamination. On systems with lubricated compressors, if bulk liquid is present, use as a prefilter ahead of the oil aerosol removal filter.
2. **Oil Aerosol Removal Filter** - On systems with lubricated compressors, use to remove oil aerosols and protect desiccant bed from oil contamination.

C. **Desiccant dryer**

D. **Afterfilters** - To ensure downstream air purity (prevent desiccant dust from traveling downstream) adequate filtration down-stream of the dryer is required. Depending on the degree of purity you require from your compressed air system, the following filters are recommended:

1. **Air Line Filter** - Use as an afterfilter to remove desiccant fines and protect downstream components from solid particles 1 micron and larger. Filters for finer solid particle filtration are available.
2. **Oil Vapor Adsorber** - Use as an afterfilter to remove oil vapor and its subsequent taste and odor and to protect downstream components from solid particles 0.01 micron and larger.

NOTE: By-pass lines and isolation valves are recommended so that maintenance work can be performed without shutting off the air supply.

IMPORTANT: The compressed air supply inlet should be periodically checked to ensure that equipment design specifications are not exceeded. Normally the compressor installation includes intercoolers, aftercoolers, separators, receivers, or similar equipment which adequately pretreat the compressed air supply in order to avoid excessively high air temperatures and liquid slugging of down-stream equipment.

3.4 PreFilter and AfterFilter Installation

If supplied, install Prefilter and Afterfilter.

NOTE: When installing, hold bulkhead fitting on dryer with wrench and thread filter on by hand.

- A. Install prefilter (F04-HF-DG1) ahead (upstream) of dryer. Use nipple supplied to connect filter to inlet port of dryer.
- B. Install afterfilter (F04-PF-TG1) downstream of dryer. Use nipple supplied to connect filter to outlet port of dryer.

NOTE: Observe arrows on differential pressure gauge to ensure proper flow direction through filter.

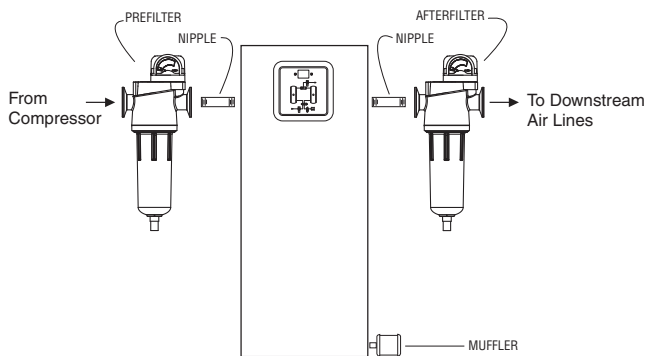

Figure 5

CUSTOMER ASSEMBLY INSTRUCTIONS

These instructions **MUST** be followed prior to mounting of dryer enclosure.

1. Connect prefilter and afterfilter to enclosure (if applicable).
2. Mount dryer.
3. Connect to inlet, outlet, and purge connections. (see NOTE)

NOTE: If the equipment is to dry (or reactivate with) a gas other than air, the outlets of the safety valve, reactivation gas outlet line, blow down valves, etc. are to be piped away to a safe location (by purchaser). In piping away gas, do not pipe upward without adequate arrangements to prevent trapping condensation.

4. Install moisture indicator downstream of dryer outlet (if applicable).

3.5 Wall-mounting

Four holes are provided in rear of cabinet. Attach cabinet to wall using four (4) screws. User is responsible for selecting screws of the appropriate strength and ensuring the wall mounting surface can safely support the weight of the dryer (See Section 3.1).

3.6 Piping

Connect air line from compressor to inlet of prefilter or dryer. Connect downstream air line to outlet of afterfilter or dryer.

3.7 Electrical Connection

Check to see that power supply to dryer is the same as the power requirements indicated on the identification label. Install plug into receptacle of proper voltage or hardwire to pigtailed and ground screw inside cabinet.

3.8 Muffler Installation

Install muffler (packaged separately inside dryer shipping box) to fitting on side of cabinet.

3.9 Moisture Indicator Installation

Install the moisture indicator (shipped separately inside of cabinet) directly into the pipe line anywhere in air/gas system where moisture level is to be monitored. If indicator is installed parallel to main line, make sure enough of a restriction exists in main line to force adequate flow through indicator.

3.10 Initial Desiccant Charge

The dryer is shipped complete with desiccant and ready to operate after piping and electrical connections are made.

4.0 OPERATION

4.1 Start-up

- A. During the initial start-up, slowly pressurize dryer to full line pressure and check entire system for leaks. Depressurize and correct any leaks.
- B. Energize the Dryer On-Off switch located on the enclosure cover (Power-on light should illuminate).

NOTE: If dryer is installed with either internally or externally mounted air by-pass valve, make certain that by-pass valve is closed to prevent untreated air from flowing downstream.

4.2 Inlet, Purge, and Outlet Flows @ 100 psig (7 kgf/cm²)

A. Inlet Flows

1. Maximum Inlet Flow at Rated Conditions
For maximum inlet flow at rated conditions refer to Table 1.

2. Maximum inlet flow at various pressures
To determine maximum inlet flow at inlet pressures other than 100 psig (7kgf/cm²), multiply inlet flow from Table 1 by multiplier from Table 2 that corresponds to system pressure at inlet of dryer.
3. Maximum inlet flow at various temperatures
To determine maximum inlet flow at inlet temperatures other than 100°F (38°C), multiply inlet flow from Table 1 by multiplier from Table 3 that corresponds to system temperature at inlet of dryer.

B. Purge Flow

For maximum and average purge flows at 100 psig (7 kgf/cm²) refer to Table 1.

1. Maximum Purge Flow
Maximum Purge Flow (MFP) is the amount of purge flowing through the off-stream tower when the purge/repressurization valve is open. After the purge/repressurization valve closes, the purge flow will gradually decrease as the off-stream tower repressurizes to line pressure. Refer to Table 1 for Maximum Purge Flows at 100 psig (7kgf/cm²).

TABLE 1 Inlet and Purge Flows @ 100 psig

MODEL	INLET FLOW (1) scfm (m ³ /h)		PURGE FLOW (2) scfm (m ³ /h)	
	-40°F (-40°C)	-100°F (-73°C)	Average	Maximum
7	7.3 (12)	5.6 (9.5)	1.5 (2.5)	2.0 (3.4)
13	13 (22)	10 (17)	2.7 (4.6)	3.7 (6.3)
20	20 (34)	16 (27)	4.2 (7.1)	5.5 (9.3)
25	25 (42)	20 (34)	5.1 (8.7)	6.8 (12)
30	30 (51)	24 (41)	6.2 (11)	8.2 (14)
35	35 (59)	28 (48)	7.2 (12)	9.6 (16)
50	50 (85)	40 (68)	10.2 (17)	13.6 (23)

1. Inlet flows are established in accordance with CAGI (Compressed Air and Gas Institute) standard ADF-200, Dual Stage Regenerative Desiccant Compressed Air Dryers - Methods for Testing and Rating. Conditions for rating dryers are: inlet pressure - 100 psig (7 kgf/cm²); inlet temperature - saturated at 100°F (38°C).
2. Average Purge Flow is the total amount of air used to purge and repressurize off-stream towers averaged over the cycle time. Maximum Purge Flow is the flow rate through the off-stream tower during that portion of the cycle the purge/repressurization valve is open.

TABLE 2 Capacity Correction Factor for various inlet pressures

INLET PRESSURE	psig	50	60	70	80	90	100	110	120	130	140	150
	kgf/cm ²	3.5	4.2	4.9	5.6	6.3	7.0	7.7	8.4	9.1	9.8	10.5
Multiplier		0.31	0.42	0.54	0.73	0.83	1.00	1.09	1.17	1.26	1.35	1.44

TABLE 3 Capacity Correction Factor for various inlet temperatures

INLET TEMPERATURE	°F	100 and below	105	110	115	120
	°C	38 and below	41	43	46	49
Multiplier		1.00	0.98	0.96	0.93	0.89

TABLE 4 Purge Flow Correction Factor for various inlet pressures

INLET PRESSURE	psig	50	60	70	80	90	100	110	120	130	140	150
	kgf/cm ²	3.5	4.2	4.9	5.6	6.3	7.0	7.7	8.4	9.1	9.8	10.5
Multiplier		0.55	0.64	0.73	0.82	0.91	1.00	1.09	1.17	1.26	1.35	1.44

TABLE 5 Outlet pressure dew points at Moisture Indicator color change

INLET TEMP.	°F (°C)	35 (2)	40 (4)	50 (10)	60 (16)	70 (21)	80 (27)	90 (32)	100 (38)	110 (43)	120 (49)
OUTLET P.D.P.	°F (°C)	-34 (-37)	-28 (-33)	-22 (-30)	-16 (-27)	-10 (-23)	-4 (-20)	3 (-16)	9 (-13)	15 (-9)	21 (-6)

2. Average Purge Flow
The Average Purge Flow (APF) is the actual amount of flow averaged over the entire purge/repressurization cycle. It includes the maximum purge flow (MFP) for a set amount of the purge/repressurization time and the volume of air used for repressurization. Refer to Table 1 for Average Purge Flows at 100 psig.
3. Purge flows at pressures other than 100 psig
To determine Maximum or Average Purge Flow at inlet pressures other than 100 psig, multiply purge flow at 100 psig from Table 1 by the multiplier from Table 4 that corresponds to system pressure at inlet to dryer.

C. Outlet Air Flow

1. Minimum Outlet Flow
Determine minimum outlet flow available from dryer by subtracting Maximum Purge Flow from inlet flow to dryer.
NOTE: Air compressor should be adequately sized to handle air system demands as well as purge loss. Failure to do so could result in overloading air compressors and/or insufficient air supply downstream.
2. Average Outlet Flow
Determine average outlet flow available by subtracting Average Purge Flow from inlet flow to dryer.
NOTE: Average outlet flow may be used to determine available downstream air supply if a storage vessel (receiver tank) of sufficient volume is available between dryer and point of air usage. Otherwise use 3.2.3.1 To compute downstream air available.

EXAMPLE:

Find maximum inlet flow, maximum and average purge flows, and minimum and average outlet flows for a 13 scfm unit operated at 120 psig. Dryer will operate with an inlet air flow of 14 scfm.

- Step 1: Find Maximum Inlet Flow by multiplying Maximum Inlet Flow at Rated Conditions from Table 1 by Inlet Pressure Correction Factor from Table 2 and Inlet Temperature Correction Factor from Table 3: $13 \times 1.17 \times 1.00 = 15.2$ scfm.
- Step 2: Find Maximum Purge Flow by multiplying Maximum Purge Flow at 100 psig from Table 1 by Purge Flow Correction Factor from Table 4: $3.7 \times 1.17 = 4.3$ scfm, the maximum purge flow.
- Step 3: Find Average Purge Flow by multiplying Average Purge Flow at 100 psig from Table 1 by Purge Flow Correction Factor from Table 4: $2.7 \times 1.17 = 3.2$ scfm, the average purge flow.

- Step 4: Find Minimum Outlet Flow available by subtracting Maximum Purge Flow (Step 2) from inlet flow of 14 scfm: $14 - 4.3 = 9.7$ scfm.
- Step 5: Find Average Outlet Flow available by subtracting Average Purge Flow (Step 3) from inlet flow of 14 scfm: $14 - 3.2 = 10.8$ scfm.

4.3 Operating Conditions

- A. **Maximum Working Pressure:** 150 psig (10.5 kgf/cm²)
- B. **Minimum Working Pressure:** 50 psig (3.5 kgf/cm²)

It is recommended that the air dryer be operated at the highest available pressure not exceeding the maximum working pressure since the dryer capacity increases and % of purge air decreases at higher pressures.

- C. **Maximum Operating Temperature:** 120°F (49°C)

4.4 Operational Check Points

- A. Check periodically that there is power to the unit - Power on light is on.
- B. If unit is equipped with optional moisture indicator, check at least once a day. Outlet relative humidity of the desiccant dryer is indicated by the color change humidity indicator. Green indicates R.H. below 3% and yellow indicates R.H. above 3%. Table 5 indicates outlet dew point when moisture indicator changes from green to yellow at various inlet temperatures. During startup the indicator may be yellow, however, it should begin to change to green within 4 hours.
- C. If supplied with optional prefilter/afterfilter. Check that indicators are in green area. If indicator is in red area element replacement is necessary.

4.5 Dryer Shutdown

To shut down the dryer, de-energize using the on-off switch (Power-on light extinguished). Unit will remain pressurized.

4.6 Depressurization

To depressurize unit

- A. Open by-pass valve (if one is installed) and close inlet and outlet valves.
- B. Run timer through a complete tower change cycle or until all air has been exhausted from the dryer.

4 MINUTE CYCLE TIMING CHART

		Cycle Time (min:sec)				
		0:00 - 0:30	0:30 - 2:00	2:00 - 2:30	2:30 - 4:00	
All Models	SOL1	Left Purge Valve	Closed	Closed	Closed	Open
	SOL2	Right Purge Valve	Closed	Open	Closed	Closed
All Models	LED	Left Tower	Flashing	On	Flashing	Off
	LED	Right Tower	Flashing	Off	Flashing	On

5.0 MAINTENANCE

CAUTION: The heatless desiccant dryer is a pressure containing device. Depressurize before servicing. (See section 4.6.)

5.1 Desiccant Replacement

IMPORTANT: The use of the correct replacement desiccant is necessary for proper drying operation. Never use hygroscopic salts of the type commonly used in “deliquescent” type dryers.

A. Frequency of Desiccant Replacement - Desiccant should be replaced whenever the required dew point cannot be maintained while the dryer is being operated within its design conditions and there are no mechanical malfunctions.

NOTE: Desiccant life is determined by the quality of the inlet air. Proper filtering of the inlet air will extend the life of the desiccant.

B. Procedure for Desiccant Replacement

1. Depressurize and de-energize the dryer.
2. Remove front panel from cabinet.
3. Disconnect tubing from top and bottom of desiccant towers and unscrew strainer assemblies. Remove the mounting screws from the outlet shuttle valve mounting bracket to aid in disconnecting the tubing at the top of the towers.

NOTE: Be prepared to catch the desiccant being removed in a container. Desiccant will readily pour out when bottom strainer is removed.

4. Allow the spent desiccant to drain from the towers.
5. Replace bottom strainer assemblies.
6. Fill the desiccant drying towers as full as possible with dry desiccant.
7. Replace top strainer assemblies.
8. Reinstall tubing to top and bottom of desiccant towers.

C. Ensuring Desiccant Dryness

1. Replacement desiccant is shipped in air tight containers. Keep containers closed until use to avoid moisture contamination. If desiccant is exposed to air it can be heated in an oven at 400°F for four hours before use, or the next procedure can be used.
2. If the dryer is not refilled with dry desiccant, it will be necessary to operate the dryer on 100% purge for approximately twenty-four hours to dry the desiccant.

Amount of desiccant required for complete change

MODEL	DESICCANT REQUIRED	
	lb	(kg)
7	7	(3.2)
13	12.8	(5.8)
20	19.4	(8.8)
25	28.7	(13.0)
30	28.7	(13.0)
35	33.6	(15.2)
50	47.6	(21.6)

5.2 Prefilter/Afterfilter Maintenance

A. Element Replacement

1. For maximum filtration efficiency, replace element annually or when pressure drop reaches 4.3 psi (0.3 bar) (indicator in red area), whichever occurs first.

B. Procedure for Element Replacement

WARNING: THIS FILTER IS A PRESSURE CONTAINING DEVICE. DEPRESSURIZE BEFORE SERVICING.

1. Isolate filter (close inlet and outlet valves if installed) or shut off air supply.
2. Depressurize filter by slowly opening manual drain valve.
3. Remove bowl by unscrewing the bowl from the filter head using hand, strap wrench or C spanner, and pulling bowl straight down.
4. Clean filter bowl.
5. Replacing complete element.
 - a) Pull off old element and discard.
 - b) Make certain that the old and new element have the same part number and the end caps are the same color.
 - c) Wipe the wall inside the filter head to remove any dirt.
 - d) Lubricate the new element o-ring on the element top cap.
 - e) Align the slot in the element top cap with the projection inside the filter head.

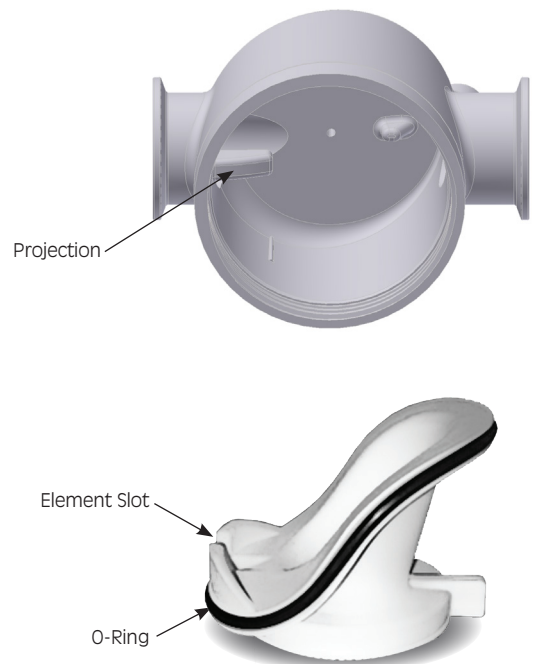

Figure 6

- f) Insert the element into the head making sure the element slot and the projection inside the filter head remain aligned.

NOTE: Handle all elements by bottom end cap only.

6. Replace housing o-ring (located at the top of the filter bowl) if needed. Make certain o-ring is generously lubricated (Use lubricant provided).
7. Reassemble bowl to head.

NOTE: Threaded bowl to head connection, generously lubricate threads with a high grade/temperature lubricant 150°F (66°C). (Use lubricant provided)

C. Auto Drain Mechanism Replacement

Prefilter only: It is recommended that drain mechanism be replaced annually.

6.0 REPAIR PARTS

	MODEL						
	7	13	20	25	30	35	50
STRAINER (TOP & BOTTOM)	3209715	3209715	3209715	3209716	3209716	3209716	3209716
SHUTTLE VALVE BODY (OUTLET VALVE)	3244971	3244972	3244973	3244974	3244975	3244976	3244977
SHUTTLE (OUTLET VALVE)	3244978	3244979	3244980	3244981	3244982	3244983	3244984
SHUTTLE VALVE BODY (INLET VALVE)	7433646	7433646	7433647	7433647	7433647	7433647	3247592
SHUTTLE (INLET VALVE)	7433648	7433648	7433649	7433649	7433649	7433649	3247593
SWITCH (ON/OFF)	3245021	3245021	3245021	3245021	3245021	3245021	3245021
CONTROLS TIMER 115V	3247594	3247594	3247594	3247594	3247594	3247594	3247594
CONTROLS TIMER 230V	3247595	3247595	3247595	3247595	3247595	3247595	3247595
PURGE/REPRESSURIZATION VALVE 115V	3209763	3209763	3209764	3209764	3209764	3209764	3247596
PURGE/REPRESSURIZATION VALVE 230V	3209765	3209765	3209766	3209766	3209766	3209766	3247597
MAINTENANCE KIT*	DHWJMKTA	DHWJMKTB	DHWJMKTC	DHWJMKT D	DHWJMKT D	DHWJMKTE	DHWJMKT F

*MAINTENANCE KITS INCLUDES MUFFLER INSET, CONDENSATE DRAIN, PREFILTER ELEMENT, AFTERFILTER ELEMENT, FILTER O-RINGS (2), DESICCANT

WARRANTY

The manufacturer warrants the product it manufactures, when properly installed, operated, applied, and maintained in accordance with procedures and recommendations outlined in manufacturer's instruction manuals, will be free from defects in material or workmanship for a period as specified below, provided such defect is discovered and brought to the manufacturer's attention within the aforesaid warranty period.

The manufacturer will repair or replace any product or part determined to be defective by the manufacturer within the warranty period, provided such defect occurred in normal service and not as a result of misuse, abuse, neglect or accident. Normal maintenance items requiring routine replacement are not warranted. The warranty covers parts and labor for the warranty period unless otherwise specified. Repair or replacement shall be made at the factory or the installation site, at the sole discretion of the manufacturer. Although not required for warranty consideration, it is recommended that the manufacturer be contacted prior to doing any warranty related service work. This action will provide guidance and instruction on the repair often times authorization to perform the work. NOTE: The manufacture reserves the right to repair, replace in the case of warranty approval or reject the warranty claim once submitted.

Unauthorized service and use of unauthorized or pirated parts voids the warranty and any resulting charges or subsequent claim will not be paid. Products repaired or replaced under warranty shall be warranted for the unexpired portion of the warranty applying to the original product.

The foregoing is the exclusive remedy of any buyer of the manufacturer's product. The maximum damages liability of the manufacturer is the original purchase price of the product or part.

THE FOREGOING WARRANTY IS EXCLUSIVE AND IN LIEU OF ALL OTHER WARRANTIES, WHETHER WRITTEN, ORAL, OR STATUTORY, AND IS EXPRESSLY IN LIEU OF THE IMPLIED WARRANTY OF MERCHANTABILITY AND THE IMPLIED WARRANTY OF FITNESS FOR A PARTICULAR PURPOSE. THE MANUFACTURER SHALL NOT BE LIABLE FOR LOSS OR DAMAGE BY REASON OF STRICT LIABILITY IN TORT OR ITS NEGLIGENCE IN WHATEVER MANNER INCLUDING DESIGN, MANUFACTURE OR INSPECTION OF THE EQUIPMENT OR ITS FAILURE TO DISCOVER, REPORT, REPAIR, OR MODIFY LATENT DEFECTS INHERENT THEREIN. THE MANUFACTURER, HIS REPRESENTATIVE OR DISTRIBUTOR SHALL NOT BE LIABLE FOR LOSS OF USE OF THE PRODUCT OR OTHER INCIDENTAL OR CONSEQUENTIAL COSTS, EXPENSES, OR DAMAGES INCURRED BY THE BUYER, WHETHER ARISING FROM BREACH OF WARRANTY, NEGLIGENCE OR STRICT LIABILITY IN TORT.

Please note that the manufacturer's warranty for this product is intended to cover manufacturing defects and therefore does not cover consumable components (desiccants, filter elements, soft goods, standard maintenance kit wear items, etc.) or components that require periodic user adjustment (expansion valve, hot gas bypass valve or cooling water regulating valve) or calibration (dew point elements/sensors, gauge calibration, etc.)

Warranty Period

One (1) year parts and labor from the date of shipment from the manufacturer or the manufacturer's authorized distributor (not to exceed eighteen (18) months from the date of shipment from the factory, whichever occurs first).

AUTHORIZATION FROM THE SERVICE DEPARTMENT IS NECESSARY BEFORE MATERIAL IS RETURNED TO THE FACTORY OR IN-WARRANTY REPAIRS ARE MADE.

SERVICE DEPARTMENT: (724) 746-1100

DHW SERIES

Pressure Swing Desiccant
Compressed Air Dryer

Models 7 through 50 scfm

SPXFLOW[®]

SPX FLOW

4647 S.W. 40th Avenue

Ocala, Florida 34474-5788 U.S.A.

P: (724) 745-1555

E: hankison.americas@spxflow.com

www.spxflow.com/hankison

Improvements and research are continuous at SPX FLOW, Inc.

Specifications may change without notice.

ISSUED 02/2019 Form No.: 3215738 Revision: I

COPYRIGHT ©2019 SPX FLOW, Inc.