

Gardner Denver

FIL SERIES COMPRESSED AIR FILTERS MODELS: FIL12 through FIL30

General Safety Information

1. Pressurized devices

⚠ WARNING

- Do not exceed maximum operating pressure indicated on serial number tag.
- Make certain filter is fully depressurized before servicing.

2. Breathing Air

- Air treated by this equipment may not be suitable for breathing without further purification. Refer to OSHA standard 1910.134 for breathing air requirements.

3. Flammable devices

⚠ WARNING

While the materials of construction are compatible with many flammable gases, the following application limitations must be considered:

- Housing materials are slightly porous. The product must be used in a well ventilated area in the absence of sparks or ignition sources. Do not use in Class 1, Division 1, Group D environments.
- The type of area - forced exhaust system used (i.e., high or low level) would be dependent on the gas involved.
- Each application (other than for air or inert gas) must be reviewed to minimize fire or explosion hazard.



CONTENTS

MODEL NUMBER CONFIGURATION	2
1.0 INSTALLATION	3
2.0 OPERATION	5
3.0 MAINTENANCE.....	6
DIMENSIONS AND WEIGHTS	7
WARRANTY	8

Model Number Configuration

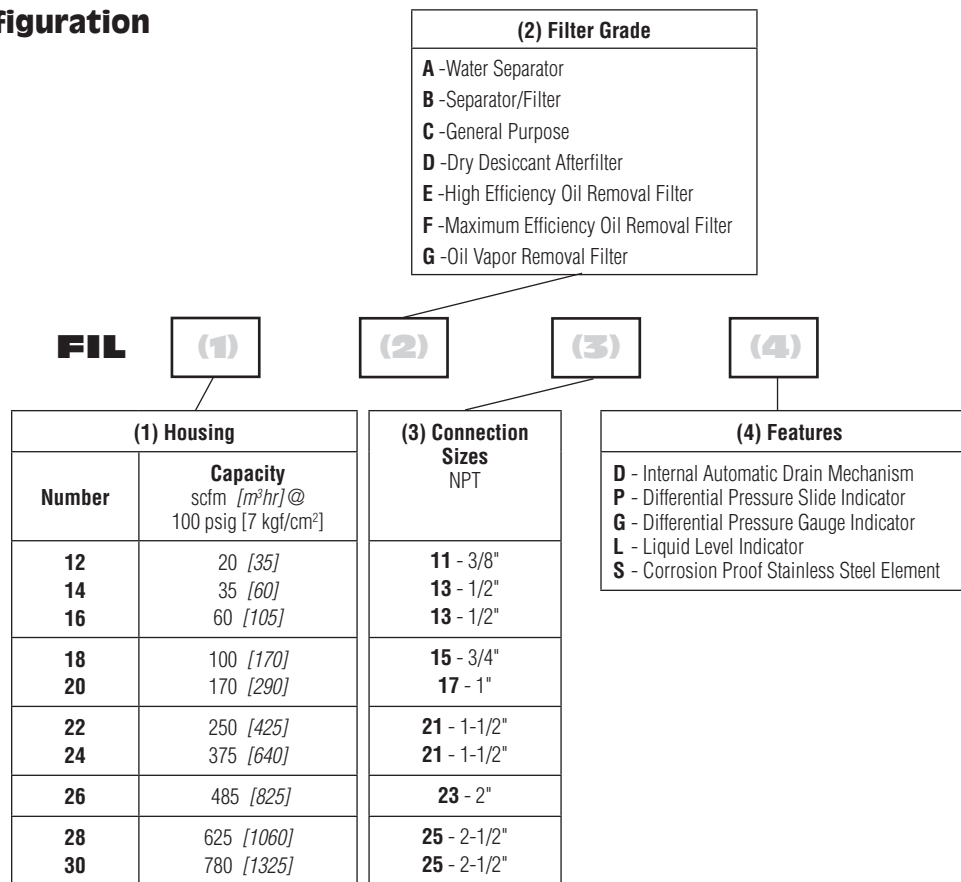

1. **Housing Number** is indicated in space (1).
2. **Filter Grade** is indicated in space (2).
3. **Connection Size** is indicated in space (3).
4. **Features** are indicated in space (4).
 D = Internal Automatic Drain Mechanism
 P = Differential Pressure Slide Indicator
 G = Differential Pressure Gauge Indicator
 L = Liquid Level Indicator
 S = Corrosion Proof Stainless Steel Element

Example: A Grade E high efficiency oil removal filter with a capacity of 100 scfm and 3/4" NPTF connections would be configured as: **FIL18E15DG**

Grade Identification

Filter grade can be identified by the third digit of the model number. In addition, elements with a foam outer sleeve can be identified by color

Grade	Description	Type	Outer foam color
A	Water Separator	Impaction type separator	none
B	Separator/filter	Mechanical separator and 3 micron coalescer	none
C	General purpose	1 micron coalescer	none
D	Dry Desiccant Afterfilter	1 micron afterfilter for desiccant dryers	none
E	High efficiency oil removal filter	High efficiency (99.99+%) coalescer	Red
F	Maximum efficiency oil removal filter	Maximum efficiency (99.999+%) coalescer	Blue
G	Oil vapor removal filter	Activated carbon adsorber	Green

1.0 Installation

A. Where Used/Air Quality After Filtration

Grade	Where used	Solid particle removal (maximum size in microns)	Liquid removal efficiency (at rated conditions)	Maximum inlet liquid loading ppm w/w	Remaining oil content ppm w/w
A	Separator - downstream of an aftercooler Point-of-use - where no aftercooler is installed upstream	—	95% of water	30,000 bulk liquids	—
B	Separator - downstream of an aftercooler Point-of-use - where no aftercooler is installed upstream or as prefilter to refrigerated dryer	3	99+% of water	25,000 aerosols & bulk liquids	5 aerosols
C	Prefilter - • Prefilter to Grade F & Grade E high efficiency filters • Point-of-use - where aftercooler is installed upstream	1	100% of water	2,000 aerosols	1 aerosols
D	Afterfilter - downstream of a pressure-swing (heatless) desiccant dryer Downstream of an Activated Carbon or Desiccant Tower	1	No liquid should be present at inlet	No liquid should be present at inlet	—
E	Prefilter - ahead of desiccant and membrane dryers Afterfilter • Downstream of refrigerated dryer • Downstream of pressure-swing (heatless) desiccant dryers for finer solid particle removal • Oil removal at point-of-use	0.01	99.99+% of oil	1,000 aerosols	0.008 aerosols
F	Prefilter - ahead of desiccant and membrane dryers (use after Grade C to reduce liquid and solids load, prolong element life and ensure filtration efficiency) Afterfilter - downstream of refrigerated dryer	0.01	99.999+% of oil	100 aerosols	0.0008 aerosols
G	Afterfilter to Grade E & Grade F for true oil free applications	0.01	Removes vapors only	No liquid should be present	0.003 vapor

B. Mounting

1. Wall mounting brackets - Mount bracket to filter head:

- (1) remove four (4) screws holding black plastic top cap to filter head
- (2) place bracket on head over plastic cap
- (3) install screws supplied with bracket.

2. Differential Pressure Gauge Mounting to Filter head

- (1) make certain o-rings are in place on the bottom of the gauge body.
- (2) connect the low pressure transmission bolt (bolt next to the RED band on gauge) to the gauge port at the filter outlet (downstream side of filter).
- (3) connect the high pressure transmission bolt (bolt next to GREEN band on gauge) to the gauge port at the filter inlet (upstream side of the filter).
- (4) use a coin or a flat head screwdriver to tighten/loosen bolts. The tip width of the screwdriver should be at least 3/8" inch (9.5 mm). Torque bolts to 25 +/-5 inch oz. **DO NOT OVER TIGHTEN.**

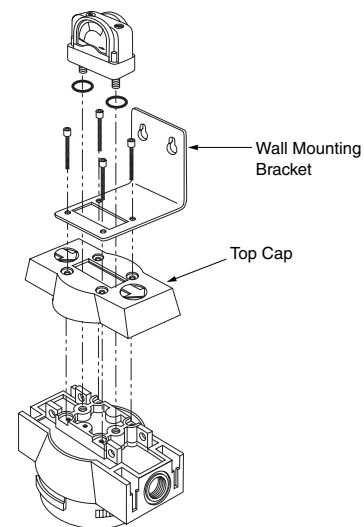
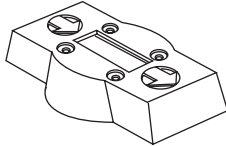

Figure 1.1

C. Piping

1. Before installing, blow out pipe line to remove scale and other foreign matter.
2. This unit has DRYSEAL pipe threads; use pipe compound or tape sparingly to male threads only.
3. Mounting (Grades A, B, C, D, E, F) - mount so that inlet and outlet connections are horizontal (filter bowl vertical) to ensure proper liquid drainage.
4. Flow Direction - install so that the air flow is in the direction of arrows on the filter head.

NOTE: Grade D flows from outside to inside of element. All other grades flow from inside to outside of element. Observe flow arrows on cap.



5. Direct filter-to-filter (modular) connection - Filter heads may be joined without using a pipe nipple

- a. Bayonet type heads - Use two (2) modular connectors, o-ring, and four (4) socket head cap screws (sold as kit).

Remove black plastic top cap, apply generous amount of lubricant to o-ring, install o-ring in groove, and insert connectors. Screw connectors to head using socket head cap screws.

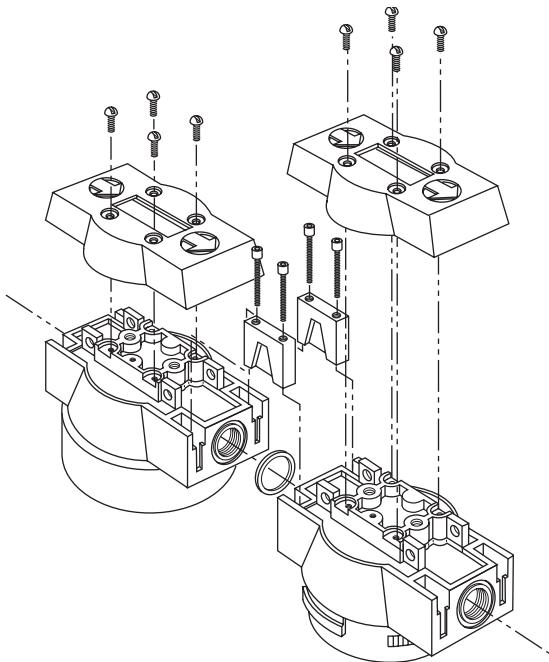

- b. Threaded heads

Use four carriage bolts, nuts and o-ring (sold as kit). Remove black plastic top caps, apply generous amount of lubricant to o-ring, install o-ring in groove, and install bolts and nuts.

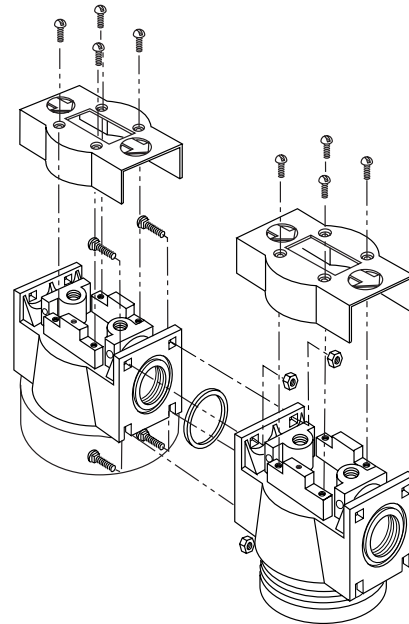

NOTE: Make certain flow direction through filters is correct (observe pin hole used for aligning top caps). Grades A, B, C, E, F, G - when hole is on side closest to you, inlet is to left. Grade D - when hole is on the side farther from you, inlet is to left.

NOTE: Lubricate o-ring with generous amount of lubricant before installation.

6. Isolation valves and by-pass piping - For ease of service, isolation and by-pass valves are desirable. In critical applications, two filters installed in parallel may be necessary to avoid interruption of air supply.

D. Drain provisions

1. Internal Automatic Drains - Drain line
The bottom of internal automatic drains are provided with 1/8" (inside threads) for connection of a drain line if desired.
2. External Auto Drains - External auto drains may be added as follows:

Models 12 through 20 - remove internal drain and install adapter (available from factory). Adapter outlet connection is 1/8" (inside threads).

⚠ WARNING Discharge is at system pressure; anchor drain line.

Models 22 through 30 - Remove adapter fitting from bottom of bowl; 1/2" (inside threads) port is available for external drain connection.

2.0 Operation

⚠ WARNING Do not operate filter at pressures in excess of Maximum Working Pressure indicated on Serial Number Tag.

NOTE: Maximum Operating Temperature - 150°F, 66°C. Liquid filtration above 120°F, 49°C is not recommended since there is typically oil present in a vapor state which passes through the filter and condenses downstream.

NOTE: Grade G - If operated above 100°F, 38°C may experience less than 1000 hours of life because of greater oil vapor content.

A. Liquid Draining - Grades A, B, C, E, F

NOTE: Collected liquids must be removed to ensure proper operation.

NOTE: Depressurize slowly, to avoid filter element damage.

1. Manual Drain - Turn to your right (clockwise) to open and to your left (counterclockwise) to close.
2. Automatic Drain - Liquids will automatically discharge when sufficient accumulation occurs.
 - a. Internally Mounted Auto Drains - These drains may be manually drained by turning to your right (clockwise) to open and to your left (counterclockwise) to close.

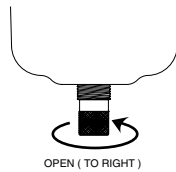

NOTE: Manually drain internal auto drains daily to verify drain function.

B. Operational Checkpoints

All Grades

Check flow, pressure, and temperature to make certain filter is being operated within design conditions.

Grades A, B, C, D, E, F

Check pressure drop across the filter

1. Pressure differential in excess of 6 psi (0.42 kgf/cm²) - pressure indicator in red area - indicates that the filter sleeve or element should be replaced.

NOTE: Element should be changed annually or when indicator changes to red, whichever occurs first.

NOTE: Pressure drop should never exceed 15 psi (1.0 kgf/cm²).

2. Check for sudden reduction in pressure drop. This might indicate:
 - a. Possible leak across element o-ring seal
 - b. Leak through the element due to physical damage

Grades A, B, C, E, F

1. Check to see that filter is installed level to insure proper drainage.
2. Check that manual drains are drained periodically or that automatic drains are functioning.
3. On models with Liquid Level Sight glass - Check that liquid level is below top of Sight glass.

Grade G

1. Check for an oily smell by opening the manual valve. If an oily smell exists, the following should be checked:
 - a. Filter element adsorption capacity exhausted.
 - b. Leak across element o-ring seal.
 - c. Leak through element due to physical damage.
 - d. Presence of liquids because of lack of or failure of prefilters.
 - e. Flow, pressure and temperatures outside design conditions.
 - f. Presence of gaseous impurities which cannot be adsorbed.

⚠ CAUTION Methane, carbon monoxide, carbon dioxide and various inorganic gases cannot be removed by an activated carbon filter.

C. Flow Capacity

Maximum air flow for the various filters at 100 psig (7 kgf/cm²) is indicated in Table 1. To determine maximum air flows at inlet pressures other than 100 psig (7 kgf/cm²), multiply flow from Table 1 by air flow correction factor from Table 2 that corresponds to the minimum operating pressure at the inlet of the filter.

NOTE: Filters should not be selected by pipe size. Select using flow rate and operating pressure only.

Table 1 - Maximum Flow @100 psig [7 kgf/cm²]

Housing	scfm	[m ³ /hr]
12	20	[35]
14	35	[60]
16	60	[105]
18	100	[170]
20	170	[290]
22	250	[425]
24	375	[640]
26	485	[825]
28	625	[1060]
30	780	[1325]

Table 2 - Air Flow Correction Factor

Maximum Inlet Pressure	psig	20	30	40	60	80	100	120	150	200	250	300
	kgf/cm ²	1.4	2.1	2.8	4.2	5.6	7.0	8.4	10.6	14.1	17.6	21.1
Correction Factor		0.30	0.39	0.48	0.65	0.82	1.00	1.17	1.43	1.87	2.31	2.74

3.0 Maintenance

A. When to Replace Filter Element

NOTE: Grades C, D, E, F, G, - complete element is replaced.

1. Grade D (dry desiccant afterfilter)
Initial drop: 1 psi (0.07 kgf/cm²). Pressure drop increases as element loads with solid particles. Replace when pressure drop reaches 6 psi (0.42 kgf/cm²) (indicator in red area) or annually, whichever occurs first. Reference page 7, Figure 3.2 for gauge scale detail.
2. Grade A (mechanical separator)
Element should not require replacement unless physically damaged. If sludge accumulates, element can be removed and cleaned with soap and water.
3. Grades B, C, E, F
 - a. Initial (dry) pressure drop: 1 psi (0.07 kgf/cm²) to 2 psi (0.14 kgf/cm²)
 - b. Operating pressure drop: As filter becomes liquid loaded (wetted), pressure drop will increase to 2 to 4 psi (0.14 to 0.28 kgf/cm²). Further pressure drop occurs as element loads with solid particles.
 - c. FOR MAXIMUM FILTRATION EFFICIENCY, REPLACE ELEMENT WHEN PRESSURE DROP REACHES 6 PSI (0.42 KGF/CM²) (INDICATOR IN RED AREA) OR ANNUALLY, WHICHEVER OCCURS FIRST. Reference page 7, Figure 3.2 for gauge scale detail.

NOTE: Pressure drop may temporarily increase when flow is resumed after flow stoppage. Pressure drop should return to normal within one hour.

NOTE: Grades E and F - During normal operation bottom of foam sleeve will have a band of oil. Spotting above the band indicates that liquids are accumulating faster than they can be drained and that prefiltration is required.

4. Grade G (activated carbon filters)
 - a. Adsorption capacity - 1000 hours at rated capacity. Element life is exhausted when odor can be detected downstream of the filter.

B. Procedure for Element Replacement

⚠WARNING THIS FILTER IS A PRESSURE CONTAINING DEVICE. DEPRESSURIZE BEFORE SERVICING. If filter has not been depressurized before disassembly, an audible alarm will sound when the bowl begins to be removed from the head. If this occurs, stop disassembly, isolate and completely depressurize filter before proceeding.

1. Isolate filter (close inlet and outlet valves if installed) or shut off air supply.
2. Depressurize filter by slowly opening manual drain valve.
3. Remove bowl
 - a. For models 12 through 20 - bayonet mount - push bowl up, turn bowl 1/8th turn to your left, and pull bowl straight down
 - b. For models 22 through 30 - threaded bowls - unscrew bowl from head using hand, strap wrench or C spanner.

4. Clean filter bowl
5. Replace element
 - a. Replacing complete element
 - 1) Pull off old element and discard.
 - 2) Make certain o-ring inside top of replacement element is in place and push element onto filter head. For Housing sizes 40 to 48, place element in bowl and secure with centering device.

NOTE: Grades E, F, and G - Do not handle elements by outside foam cover. Handle by bottom end cap only.

6. After making certain that o-ring inside top of bowl (and on bayonet mount heads, wave spring) are in place, reassemble bowl to head.

NOTE: Make certain o-ring is generously lubricated.

NOTE: Wave spring ends should be pointed down to prevent the wave spring from interfering with reassembly.

NOTE: Threaded bowl to head connection, generously lubricate threads with a high grade/temperature lubricant good for 150°F, 66°C.

C. Auto Drain Mechanism

It is recommended that drain mechanism be replaced annually.

Dimensions and Weights

Filter Type	12	14	16	18	20	22	24	26	28	30
Replacement Element	12 or 12S	14 or 14S	16 or 16S	18 or 18S	20 or 20S	22 or 22S	24 or 24S	26 or 26S	28 or 28S	30 or 30S
Nominal Air Flow scfm @100 psig (m ³ /hr @ 7.0 bar)	20 (35)	35 (60)	60 (105)	100 (170)	170 (290)	250 (425)	375 (640)	485 (825)	625 (1060)	780 (1325)
In/Out Connection	3/8	1/2	1/2	3/4	1	1-1/2	1-1/2	2	2-1/2	2-1/2
"A" in. (mm)	4.13 (105)	4.13 (105)	4.13 (105)	5.25 (133)	5.25 (133)	6.44 (164)	6.44 (164)	7.63 (194)	7.63 (194)	7.63 (194)
"B" in. (mm)	7.88 (200)	10.05 (255)	12.40 (316)	13.32 (338)	17.57 (446)	20.80 (528)	25.29 (642)	29.08 (739)	34.83 (885)	40.96 (1040)
"C" in. (mm)	6.40 (163)	8.59 (224)	10.97 (285)	11.74 (298)	15.99 (406)	18.98 (482)	23.47 (596)	26.83 (681)	32.58 (827)	38.71 (983)
"D" in. (mm)	3.00 (76)	3.00 (76)	3.00 (76)	3.50 (89)	3.50 (89)	4.00 (102)	4.00 (102)	4.00 (102)	4.00 (102)	4.00 (102)
Weight lb. (kg)	4.2 (190)	4.5 (2.04)	4.7 (2.132)	6.3 (2.9)	6.9 (3.1)	10.2 (4.63)	11.3 (5.13)	28 (12.70)	33 (14.97)	38 (17.24)
Maximum Working Pressure	Housing - 300 psig, 21.1 kgf/cm ² Models with Internal Drain or Liquid level indicator - 250 psig, 17.6 kgf/cm ²									
Maximum Operating Temperature	150°F, 66°C									
Head Material	Aluminum			Aluminum			Aluminum			
Bowl Material	Aluminum			Aluminum						
Liquid Level Indicator Material	Isoplast			Isoplast						

NOTE: Dimensions and Weights are for reference only. Request certified drawings for construction purposes.

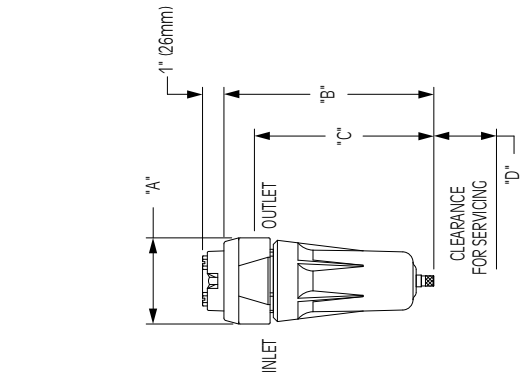

FIL(Grade) 12, 14, 16

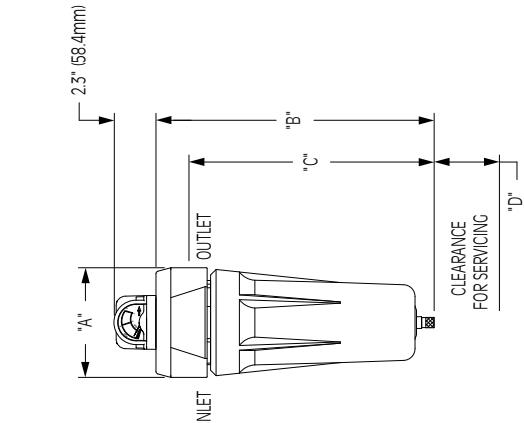

FIL(Grade) 18, 20

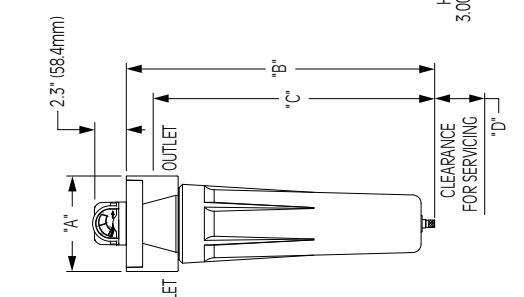

FIL(Grade) 22, 24

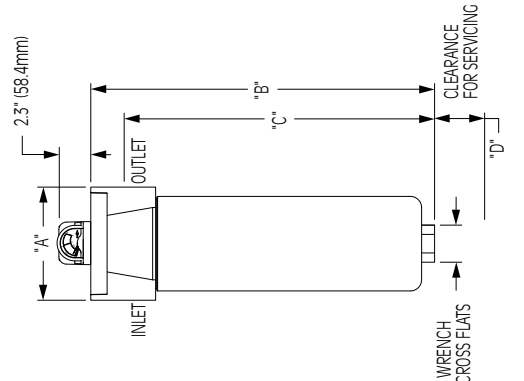

FIL(Grade) 26, 28, 30

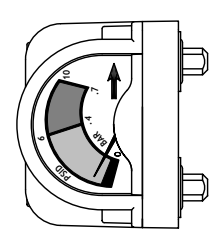

Figure 3.2
Differential Pressure
Gauge

WARRANTY

The manufacturer warrants the product manufactured by it, when properly installed, operated, applied, and maintained in accordance with procedures and recommendations outlined in manufacturer's instruction manuals, to be free from defects in material and workmanship for a period of one (1) year from date shipment to the buyer by the manufacturer or manufacturer's authorized distributor provided such defect is discovered and brought to the manufacturer's attention within the aforesaid warranty period.

The manufacturer will repair or replace any product or part determined to be defective by the manufacturer within the warranty period, provided such defect occurred in normal service and not as a result of misuse, abuse, neglect or accident. Normal maintenance items requiring routine replacement are not warranted. The warranty covers parts and labor for the warranty period. Repair or replacement shall be made at the factory or the installation site, at the sole option of the manufacturer. Any service performed on the product by anyone other than the manufacturer must first be authorized by the manufacturer.

Unauthorized service voids the warranty and any resulting charge or subsequent claim will not be paid.

Products repaired or replaced under warranty shall be warranted for the unexpired portion of the warranty applying to the original product.

The foregoing is the exclusive remedy of any buyer of the manufacturer's product. The maximum damages liability of the manufacturer is the original purchase price of the product or part.

THE FOREGOING WARRANTY IS EXCLUSIVE AND IN LIEU OF ALL OTHER WARRANTIES, WHETHER WRITTEN, ORAL, OR STATUTORY, AND IS EXPRESSED IN LIEU OF THE IMPLIED WARRANTY OF MERCHANTABILITY AND THE IMPLIED WARRANTY OF FITNESS FOR A PARTICULAR PURPOSE. THE MANUFACTURER SHALL NOT BE LIABLE FOR LOSS OR DAMAGE BY REASON OF STRICT LIABILITY IN TORT OR ITS NEGLIGENCE IN WHATEVER MANNER INCLUDING DESIGN, MANUFACTURE OR INSPECTION OF THE EQUIPMENT OR ITS FAILURE TO DISCOVER, REPORT, REPAIR, OR MODIFY LATENT DEFECTS INHERENT THEREIN.

THE MANUFACTURER, HIS REPRESENTATIVE OR DISTRIBUTOR SHALL NOT BE LIABLE FOR LOSS OF USE OF THE PRODUCT OR OTHER INCIDENTAL OR CONSEQUENTIAL COSTS, EXPENSES, OR DAMAGES INCURRED BY THE BUYER, WHETHER ARISING FROM BREACH OF WARRANTY, NEGLIGENCE OR STRICT LIABILITY IN TORT.

The manufacturer does not warrant any product, part, material, component, or accessory manufactured by others and sold or supplied in connection with the sale of manufacturer's products.

AUTHORIZATION FROM THE SERVICE DEPARTMENT IS NECESSARY BEFORE MATERIAL IS RETURNED TO THE FACTORY OR IN-WARRANTY REPAIRS ARE MADE.

**For Sales and Service: (800) 883-2477
Or visit Sales and Service at www.gardnerdenverproducts.com**

**Gardner
Denver**

For additional information contact
you local representative or

Gardner Denver Inc.
1800 Gardner Expressway, Quincy, IL 62305
Telephone: (800) 682-9868
FAX: (217) 224-7814

Visit our Web Site: www.gardnerdenverproducts.com

© 2015 Gardner Denver, Inc. Printed in U.S.A

3150962 Rev. B 04/15
18-5-605

