



HL Series Desiccant Dryer MODELS 800-5000

Operator's Manual

EN Operator's Manual



Save These Instructions



1.0 CONTENTS

2.0 INTRODUCTION	3	9.6 ELECTRICAL CONNECTION.	14
3.0 WARRANTY	3	9.7 DESICCANT LEVEL VERIFICATION	14
4.0 HEATLESS DRYER NOMENCLATURE.	3	9.8 START-UP	14
5.0 RECEIVING AND INSPECTION.	4	9.9 SHUT-DOWN SEQUENCE	15
5.1 INSPECTION	4	10.0 TECHNICIAN MODE	16
5.2 UNPACKING AND HANDLING	4	10.1 ENTERING TECHNICIAN MODE	16
6.0 SAFETY AND OPERATION PRECAUTIONS	4	10.2 DEW POINT ADJUSTER (-40 °F DRYERS ONLY)	16
7.0 PRINCIPLES OF OPERATION	5	10.3 ENERGY MANAGEMENT SYSTEM (OPTIONAL)	16
7.1 INTRODUCTION.	5	10.3.1 DESCRIPTION AND ACTIVATION	16
7.2 DRYING CYCLE	5	10.3.2 SETPOINT ADJUSTMENT	17
7.3 REGENERATION CYCLE	5	10.4 RESTART MODE	17
7.4 SETTING THE REGENERATION AIR FLOW.	5	10.5 PURGE FLOW ADJUSTER	17
7.5 TOWER REPRESSURIZATION.	5	10.6 COMPRESSOR INTERLOCK	18
7.6 VALVES	5	10.7 HIGH DEW POINT ALARM (INCLUDED WITH EMS OPTION)	18
7.7 TIMING SEQUENCE.	6	10.7.1 DESCRIPTION AND ACTIVATION	18
7.7.1 TIMING CYCLE FOR -40°F DEW POINT DRYERS.	6	10.7.2 SETPOINT ADJUSTMENT	18
7.7.2 TIMING CYCLE FOR -100°F DEW POINT DRYERS.	6	11.0 MAINTENANCE AND SYSTEM CHECK	20
7.8 CONTROLS	6	11.1 SCHEDULED MAINTENANCE	20
7.8.1 BASIC USER INTERFACE	6	11.2 PRE-FILTERS AND POST-FILTERS	20
7.8.2 MICROPROCESSOR CONTROL DISPLAY PARAMETERS	8	11.3 PILOT AIR CONTROL NO-LOSS DRAIN VALVES	21
7.8.3 ALARMS AND THEIR FUNCTIONS	8	11.4 MUFFLER CHANGEOUT PROCEDURE	21
7.8.4 RESTART MODES AND OPERATING DISPLAYS	10	11.5 PURGE AND SWITCHING DIAPHRAGM VALVES (HL800 - HL 2700)	21
8.0 ALARMS AND INDICATORS	11	11.6 PILOT OPERATED ACTUATOR (HL3300 - HL5000)	21
8.1 MOISTURE INDICATOR	11	11.7 OUTLET CHECK VALVES	21
8.2 FAILURE TO SHIFT ALARM (OPTIONAL)	11	11.8 DESICCANT CHANGEOUT PROCEDURE.	22
8.3 ENERGY MANAGEMENT SYSTEM (EMS) - (OPTIONAL)	11	11.9 SCHEDULED MAINTENANCE, SYSTEM CHECK.	24
8.4 HIGH DEW POINT ALARM (INCLUDED WITH EMS).	11	11.10 SCHEDULED MAINTENANCE, MAINTENANCE CHART.	25
8.5 COMPRESSOR INTERLOCK	11	12.0 TROUBLESHOOTING.	26
9.0 INSTALLATION AND INITIAL START-UP	12	13.0 PURGE CHARTS.	27
9.1 APPLICATION AND CHECK ANALYSIS	12	14.0 GENERAL ARRANGEMENT	29
9.2 LOCATING AND MOUNTING.	12	15.0 WIRING DIAGRAM	35
9.3 PIPING	12	16.0 FLOW DIAGRAM	36
9.4 FILTRATION.	12	17.0 REPLACEMENT PARTS.	38
9.4.1 AUTOMATIC DRAIN VALVE	13	18.0 ENGINEERING SPECIFICATIONS	43
9.5 DEW POINT TRANSMITTER INSTALLATION (OPTIONAL)	13		

2.0 INTRODUCTION

The **Ingersoll Rand** Heatless Desiccant Dryers are designed to adsorb moisture from compressed air. The dryers are constructed with two towers, each containing desiccant beads, that alternate between online (drying) and offline (regenerating) modes, yielding a continuous stream of dry air at the dryer's outlet.

During normal operation, wet air passes through the on line tower and water vapor from the air is adsorbed (collected) on the desiccant beads. While air is being adsorbed in the online tower, the moisture on the desiccant in the offline tower is removed by a process called desorption

(regeneration). After an initial rapid depressurization, a portion of dried air from the online tower passes over the desiccant bed and carries the moisture off the bed and out the dryer's exhaust.

The continuous, alternating process of adsorption and desorption is controlled using a timer that switches the towers in a specific timed sequence. Very dry compressed air dew points are achieved through the continuous switching and operation of this dryer. **Ingersoll Rand** offers dryers to provide either -40°F or -100°F pressure dew point outlet air.

3.0 WARRANTY

The Company warrants that the equipment manufactured by it and delivered hereunder will be free of defects in material and workmanship for a period of twelve months from the date of placing the Equipment in operation or eighteen months from the date of shipment from the factory, whichever shall first occur. The Purchaser shall be obligated to promptly report any failure to conform to this warranty, in writing to the Company in said period, whereupon the Company shall, at its option, correct such nonconformity, by suitable repair to such equipment or, furnish a replacement part F.O.B. point of shipment, provided the Purchaser has stored, installed, maintained and operated such Equipment in accordance with good industry practices and has complied with specific recommendations of the Company. Accessories or equipment furnished by the Company, but manufactured by others, shall carry whatever warranty the manufacturers have conveyed to the Company and which can be passed on to the Purchaser. The Company shall not be liable for any repairs, replacements, or adjustments to the Equipment or any costs of labour performed by the Purchaser or others without Company's prior written approval.

The effects of corrosion, erosion and normal wear and tear are specifically excluded. Performance warranties are limited to those specifically stated within the Company's proposal. Unless responsibility for meeting such performance

warranties are limited to specified tests, the Company's obligation shall be to correct in the manner and for the period of time provided above.

THE COMPANY MAKES NO OTHER WARRANTY OR REPRESENTATION OF ANY KIND WHATSOEVER, EXPRESSED OR IMPLIED, EXCEPT THAT OF TITLE, AND ALL IMPLIED WARRANTIES OF MERCHANT ABILITY AND FITNESS FOR A PARTICULAR PURPOSE, ARE HERBY DISCLAIMED.

Correction by the Company of non conformities whether patent or latent, in the manner and for the period of time provided above, shall constitute fulfilment of all liabilities of the Company for such non conformities whether based on contract, warranty negligence, indemnity, strict liability or otherwise with respect to or arising out of such Equipment.

The Purchaser shall not operate Equipment which is considered to be defective, without first notifying the Company in writing of its intention to do so. Any such use of Equipment will be at Purchaser's sole risk and liability.

Note that this is **Ingersoll Rand** standard warranty. Any warranty in force at the time of purchase of the equipment or negotiated as part of the purchase order may take precedence over this warranty.

4.0 HEATLESS DRYER NOMENCLATURE

PREFIX	NOMINAL* FLOW (m ³ /hr)	POWER / DEW POINT	NEMA/ MAWP	ELECTRICAL OPTION	ELECTRICAL OPTION	MECHANICAL OPTION	FILTERS
HL	800-5000	1 = 115 / -40 B = 115/ -100 3=200-1-50/-40 E=220-1-50/-100	H = NEMA 4 / 150 psig MAWP	0 = Standard F = EMS for Heatless Dryers	0 = Standard	A = Downstream Purge (Standard)	A = Filters Attached L = Filters Loose

* Nominal Flows indicated are for 100°F inlet temperature, 100°F ambient temperature and 100 psig compressed air pressure.

NOTICE

Nomenclature shown above represents standard price sheet options. Other options are available, refer to nomenclature insert specific to your dryer for details.

5.0 RECEIVING AND INSPECTION

5.1 INSPECTION

Upon receiving your **Ingersoll Rand** air dryer, please inspect the unit closely. If rough handling has been detected, please note it on your delivery receipt, especially if the dryer will not be immediately uncrated. Obtaining the delivery person's signed agreement to any noted damages will facilitate any insurance claims

5.2 UNPACKING AND HANDLING

 WARNING
Under no circumstances should any person attempt to lift heavy objects without proper lifting equipment (i.e., crane, hoist, slings or fork truck). Lifting any unit without proper lifting equipment, can cause serious injury.

Refer to labels on the dryer for the appropriate means for lifting or moving the dryer. When lifting the dryer, ensure that no stress is applied to the piping or valving. Refer to Section 9.2 for locating and mounting of dryer.

6.0 SAFETY AND OPERATION PRECAUTIONS

Because an air dryer is pressurized and contains rotating parts, the same precautions should be observed as with any piece of machinery of this type where carelessness in operation or maintenance could be hazardous to personnel. In addition to obvious safety rules that should be followed with this type of machinery, safety precautions as listed below must be observed:

1. Only qualified personnel shall be permitted to adjust, perform maintenance or repair this air dryer.
2. Read all instructions completely before operating unit.
3. Pull main electrical disconnect switch and disconnect any separate control lines, if used, before attempting to work or perform maintenance on the unit.
4. Do not attempt to service any part while machine is in an operational mode.
5. Do not attempt to remove any parts without first relieving the entire air system of pressure.
6. Do not operate the dryer at pressures in excess of its rating.
7. Do not operate the dryer without guards, shields and screen in place.
8. Inspect unit daily to observe and correct any unsafe operating conditions.

OSHA Heading Descriptions

 WARNING
"Warning" is used to indicate a hazardous situation which has some probability of death or severe injury. Warning should not be considered for property damage accidents unless personal injury risk is present.

 CAUTION
"Caution" is used to indicate a hazardous situation which may result in minor or moderate injury.

NOTICE
"Notice" is used to indicate a statement of company policy as the message relates directly or indirectly to the safety of personnel or protection of property. Notice should not be associated directly with a hazard or hazardous situation and must not be used in place of "Danger," "Warning," or "Caution."

NOTICE
The user of any air dryer manufactured by Ingersoll Rand, is hereby warned that failure to follow the above Safety and Operation Precautions may result in personal injury or equipment damage. However, Ingersoll Rand does not state as fact, nor does it mean to imply, that the preceding list of Safety and Operating Precautions is all inclusive, and further, that the observance of this list will prevent all personal injury or equipment damage.



7.0 PRINCIPLES OF OPERATION

7.1 INTRODUCTION

As described in Section 2, water vapor is removed from compressed air by diverting air flow alternately between two towers filled with desiccant. While one tower processes the compressed air stream, adsorbing water vapor, the opposite tower is regenerated by desorbing the water vapor and venting it to atmosphere. Refer to the Flow Diagram for a visual representation of the drying and regenerating cycles.

7.2 DRYING CYCLE

Saturated compressed air enters the dryer and is diverted to the appropriate tower by the Inlet Flow Valves. Referring to the Flow Diagram (Section 16.0), the Left Inlet Flow Valve is actuated to a closed position to prevent air flow from entering the regenerating tower. Simultaneously, the Right Inlet Flow Valve is actuated to an open position, allowing air flow to the right hand tower. During this time, the Right Tower Purge Valve is actuated to a closed position, preventing the compressed air from venting to atmosphere. As the compressed air flows through the desiccant material at pressure, removal of water vapor from the air stream begins to occur through adsorption. In the adsorption process, the desiccant material draws water vapor out of the compressed air and "holds" it until the right tower drying cycle is complete. Compressed air flows out of the tower for delivery to the process use. The Outlet Flow Check Valves provide air flow diversion to the outlet air connection of the dryer. The Right Outlet Flow Check Valve allows air flow through to the outlet connection of the dryer while The Left Outlet Flow Check Valve checks off to prevent flow back to the regenerating tower.

7.3 REGENERATION CYCLE

Previously adsorbed moisture, removed from the process stream, gets stripped or desorbed from the desiccant material in the regeneration process. The first stage of regeneration is tower depressurization. After the Inlet Flow Valves are switched to divert air flow away from the regenerating tower, the appropriate Purge Valve will be opened and the tower will be depressurized. Through rapid depressurization, a significant portion of the previously adsorbed water vapor is stripped off of the desiccant material and exhausted to atmosphere.

The second stage of regeneration uses a portion of the dry, compressed air, expanded to atmospheric pressure to complete the desorption process. As shown on the Flow Diagram, the compressed air exits the drying tower and a portion of the air flows through the Purge Adjustment Valve and the Purge Orifice. Once the air has passed through Purge Orifice, it expands to atmospheric pressure and continues the regeneration process. Desorption occurs as the desiccant releases water vapor into the regeneration air and is exhausted through the Purge Muffler.

Heatless dryers are equipped with the ability to use air from a downstream source to purge the regenerating towers. This feature is useful for applications with downstream (dry) storage tanks, as pulling air from a downstream source can minimize cycling of the air compressor.

7.4 SETTING THE REGENERATION AIR FLOW

Proper setting of the purge is necessary to achieve proper dryer performance. Setting the purge flow too high will waste compressed air and if set too low, the dryer will not achieve proper dew point performance.

The purge adjustment manifold consists of the Purge Adjustment Valve, the Purge Pressure Gauge and the Purge Orifice. Manually adjust the Purge Adjustment Valve until the gauge reading on the purge pressure gauge matches the Purge Pressure Gauge setting listed on the laminated tag affixed to the Orifice Plate Assembly.

NOTICE

On dryers equipped with the optional EMS feature, the purge valve MUST be set to the factory set point to ensure proper operation of this feature.

7.5 TOWER REPRESSURIZATION

Upon completion of tower regeneration, and prior to the Inlet Flow Valves changing position to switch towers, the regenerated tower must be repressurized.

NOTICE

Failure to re-pressurize prior to tower switchover will result in shocking the desiccant material and cause premature desiccant dusting.

Repressurization is accomplished by closing the appropriate Purge Valve. Closing the Purge Valve allows the regeneration air to begin to pressurize the tower. In addition to the regeneration air, the Repressurization Valve, (standard on -100°F dew point and high pressure dryers) opens allowing some additional air from the outlet of the dryer to ensure adequate pressurization. During normal tower regeneration, the Repressurization Valve is held closed so that the only source of air for regeneration passes through the purge adjustment assembly.

7.6 VALVES

Solenoid control valves are used to actuate the Flow Valves, Purge Valves and the optional Repressurization Valve on Heatless Dryers. The Inlet Flow Valves and optional Repressurization Valve are normally open valves, while the Purge Valves are connected as normally closed valves. This arrangement permits air to flow through the dryer during periods of loss of power.

7.0 PRINCIPLES OF OPERATION

Outlet Check Valves are single direction check valves that will allow flow in the direction shown on the Flow Diagram, but not allow flow in the opposite direction.

7.7 TIMING SEQUENCE

All timing functions are controlled by the Microprocessor Controller. Timing for HL Series dryers is as follows:

7.7.1 TIMING CYCLE FOR -40°F DEW POINT DRYERS

The standard timing cycle for -40°F operation switches the Inlet Flow Valve position every five minutes which alternates the drying tower. At the same time as a tower Inlet Valve opens, the appropriate tower Purge Valve opens to depressurize the regenerating tower. Tower regeneration occurs for 4 minutes and 15 seconds, at which time the Purge Valve closes to initiate repressurization.

7.7.2 TIMING CYCLE FOR -100°F DEW POINT DRYERS

The standard timing cycle for -100°F operation switches the Inlet Flow Valve position every 2 minutes which alternates the drying tower. At the same time as a tower Inlet Valve opens, the appropriate tower Purge Valve opens to depressurize the regenerating tower. Tower regeneration occurs for 1 minute and 50 seconds, at which time the Purge Valve closes to initiate repressurization. The Repressurization Valve opens to assist tower repressurization for the last 10 seconds prior to Inlet Flow Valve switching.

7.8 CONTROLS

The Microprocessor Controller controls all pneumatic valve operation and dryer functions as well as communicates dryer alarms. The Microprocessor Controller stores the last 20 alarm conditions, displaying the alarm and the time and date the alarm occurred. This useful feature can greatly facilitate troubleshooting of the dryer.

The Microprocessor Controller features three levels of access. The default level CUSTOMER MODE permits viewing of various drying parameters. A protected TECHNICIAN MODE permits access to and manipulation of additional parameters. A password protected FACTORY MODE is also included for use with **Ingersoll Rand** Service Personnel for troubleshooting the dryer.

7.8.1 BASIC USER INTERFACE

The Microprocessor Control display provides the user with the operating parameters and their corresponding values. When power is supplied to the dryer, the Microprocessor Control will illuminate and default to the "Standby" mode, displaying the "Press ON" prompt.

The following illustration summarizes the keypad functions.

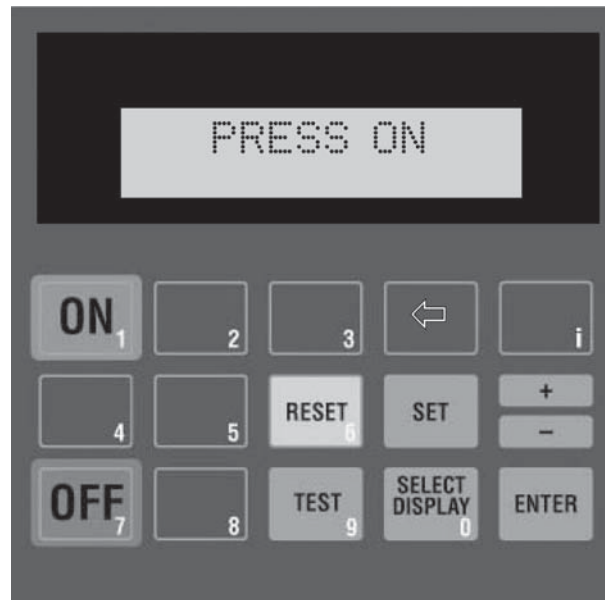

FIGURE 1 - MICROPROCESSOR CONTROLLER

7.0 PRINCIPLES OF OPERATION

BUTTONS

- ON
Initiates PLC program. Begins system monitoring and valve switching functions.
- OFF
Stops PLC program. Stops valve switching functions. Initiates shutdown sequence. Opens Inlet Flow Valves. Closes Purge Valves.
- SELECT DISPLAY
Allows the user to scroll through the available displays. The last display selected will remain displayed as the default display.
- + / -
Allows user to modify set point values. Set point values cycle through a fixed range. Also allows entering negative numbers in Factory Modes.
- ↶ or "blank" button
Allows user to step backwards to the previous level of the menu.
- RESET
Pressing once clears the local alarm indication and de-energizes the remote alarm contact for many alarm conditions. Should the alarm condition persist, the alarm will return after the alarm inhibit time has expired.
- SET
Permits the adjustment of parameters in FACTORY MODES.
- ENTER
Used to accept changed parameters and set point values.
- TEST
Not used in Desiccant Dryer applications
- i
Restricted Level access for factory use only.

The status panel provides clear indication of dryer status via bright LED indicators.

The following illustration summarizes the panel's features:

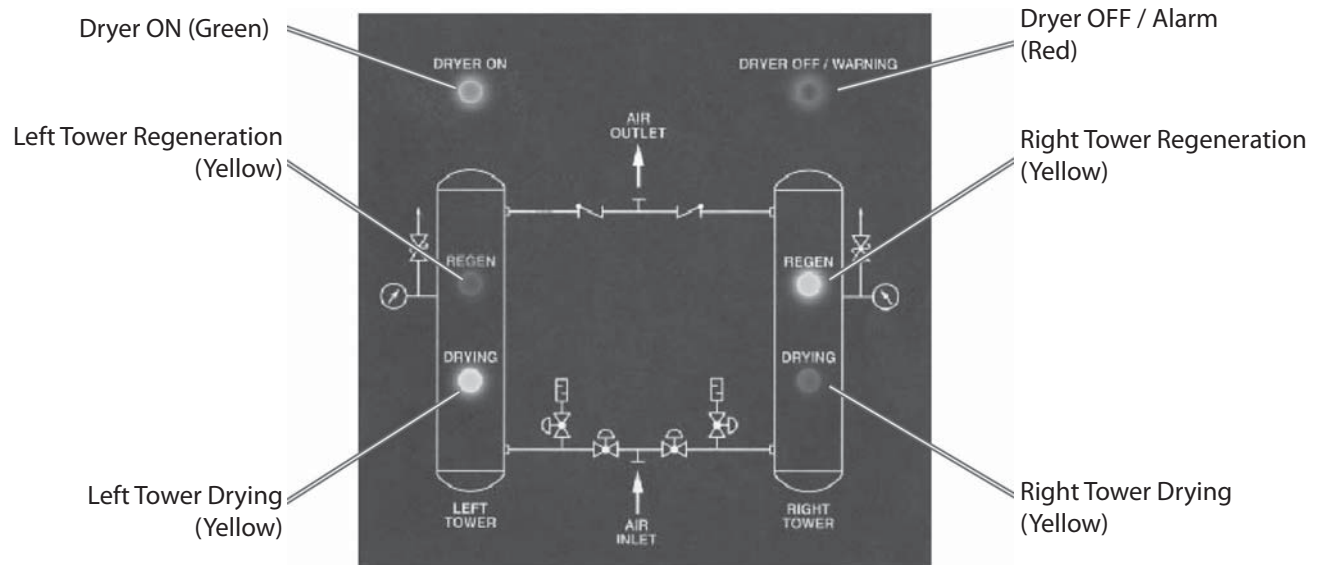

FIGURE 2 - STATUS PANEL

7.0 PRINCIPLES OF OPERATION

7.8.2 MICROPROCESSOR CONTROL DISPLAY PARAMETERS

The Microprocessor Controller is capable of displaying a number of system parameters. The following summarizes the parameters that can be accessed by depressing the SELECT DISPLAY button from the Microprocessor Controller. (Note that some displays are optional and may not appear on all models):

- Tower Status {LT DRY / RT REGEN or LT REGEN / RT DRY}: Provides visual confirmation of tower drying and regenerating status.
- Step Timer {ie STEP 4 TIME 120}: Information screen displaying the current step in the program and the time remaining for the displayed step.
- Dew Point Temperature (OPTIONAL) - {DEW POINT TEMP: XX}: When equipped with the Energy Management System (EMS) feature, provides accurate display of dryer outlet pressure dew point.
- Purge Status (OPTIONAL) - {PURGE / NO PURGE}: Indicates whether unit is currently consuming purging air. Requires EMS.
- Alarms {ALARM LIST - PRESS ENTER}: Depressing <ENT> at this prompt permits viewing of current alarm status and alarm history.
- Operating & Purge Times - {OPERATING TIMES - PRESS ENTER}: Depressing <ENT> at this prompt provides access to the operating and purge hours of operation.
- Operating Mode {OPERATING MODE: HEATLESS}: Indicates mode of operation for dryer.

7.8.3 ALARMS AND THEIR FUNCTIONS

There are several alarms detected by the Microprocessor Control to alert the user of an out of tolerance condition. Once each alarm is detected, a description of the alarm will appear in the screen and the remote alarm contact will close. Note that during the alarm condition, the SELECT DISPLAY button may be depressed to scroll through the available parameters. After approximately 30 seconds, the alarm screen will reappear, provided the alarm condition persists.

Fail to Shift Alarm (OPTIONAL) - (FAIL TO SHIFT) Pressure switches are provided to detect the pressure within each tower. At "0" psig the switches are normally closed which sends a signal to the controller. When the towers pressurize, the switches

open, thus removing the signal to the controller. During the cycle, the Microprocessor Controller interrogates the pressure switches to determine their current position. The Microprocessor Controller compares their position to a look-up table within the program. If the position of either switch differs from the switch's proper position, the dryer will initiate the Fail to Shift Alarm.

High Dew Point Alarm (OPTIONAL) - (HIGH DEW POINT) When the heatless dryer is equipped with the optional EMS feature, a sensor is provided that senses the outlet pressure dew point of the air and displays the value on the Microprocessor Controller. For dryers equipped with the optional EMS feature, the sensor is used to detect a high dew point condition and displays the alarm as "High Dew Point".

Alarm List

The Microprocessor Controller stores the 20 most recent alarm conditions. These alarms are stored with the type of alarm as well as the date and time the alarm occurred. This list can greatly facilitate troubleshooting the dryer and provide an indication of dryer operation during unattended service. The following describe the method to access and review the alarms stored in the Microprocessor Controller:

Depressing the SELECT DISPLAY button will reveal the previous alarm condition(s), as well as the remaining available alarm placeholders for alarms. To EXIT the ALARM LIST, perform the following:



ALARM LIST
PRESS ENTER

Depress the SELECT DISPLAY button until the ALARM LIST display appears.



BEGIN ALARMS

Depressing the ENTER button enters the ALARM LIST menu.



ALARM OFF

Depressing the SELECT DISPLAY button advances the menu to the current alarm status.

7.0 PRINCIPLES OF OPERATION



HIGH DEW POINT
TM 1635 DATE 1104

Depressing the SELECT DISPLAY list displays the most recent of the alarms stored by the Microprocessor Control. Refer to the diagram at the end of this section for an explanation of the ALARM LIST Display.



ALARM LIST
PRESS ENTER

Depressing the ⇐ button again returns the controller to the CUSTOMER MODE.

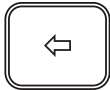

BEGIN ALARMS

Depressing the ⇐ button returns the controller to

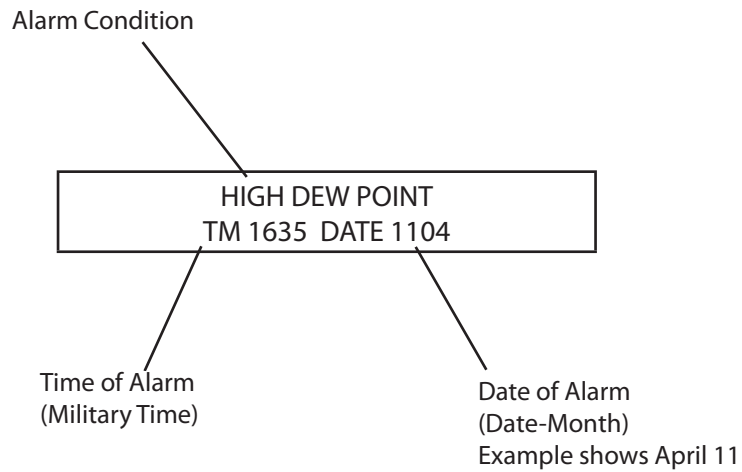

FIGURE 3 - ALARM SCREEN DETAILS

7.0 PRINCIPLES OF OPERATION

7.8.4 RESTART MODES AND OPERATING DISPLAYS

7.8.4.1 Restart Mode

The Microprocessor Controller includes a Shutdown Sequence that is activated when the dryer OFF button is depressed. This feature positions the valves to their failsafe position and resets the program and is the recommended method of shutting down the dryer. When the dryer is subsequently energized, the dryer is ready to run at the start of the program. Should the Desiccant dryer power fail unexpectedly, the dryer may be set to restart in one of two start modes.

Manual Mode (ZERO)

Ingersoll Rand dryers are shipped from the factory in the Manual Mode. After power is supplied to the dryer after a loss of power, the "PRESS ON" display will appear. The valve switching and timing operations will only start once the ON button is depressed. In this configuration, to restart the dryer, the user must manually depress the ON button on the Microprocessor Control panel.

Auto Restart Mode (LAST)

In this mode, the dryer will start automatically once power is re-applied to the dryer. The Microprocessor Control will pick up where it left off in the program once power is applied.

7.8.4.2 Operation Hours

In the CUSTOMER MODE, the Microprocessor Controller provides access to the operating hours of the dryer. The following describe the method to access and review the operating and purge hours for the dryer:

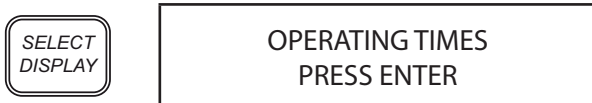

Depress the SELECT DISPLAY button until the OPERATING TIMES display appears.



Depressing the ENTER button enters the OPERATING TIMES menu.

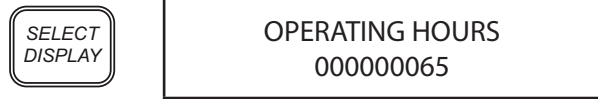

Depressing the SELECT DISPLAY button displays the cumulative operating hours of the dryer.



Depressing the SELECT DISPLAY button displays the cumulative hours the dryer has used purge air.

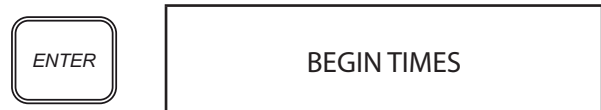

Depressing the ENTER button returns the display to the top of the OPERATING TIMES menu.

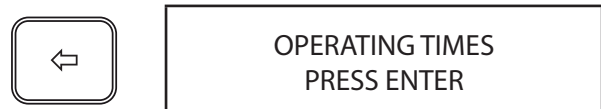

Depressing the ← button returns the controller to the CUSTOMER MODE

8.0 ALARMS AND INDICATORS

8.1 MOISTURE INDICATOR

The moisture indicator senses a sample of the control air which is taken from the dryer outlet. The indicator provides a gross indication of dew point deterioration at the outlet of the dryer. Under normal operating conditions, the indicator is blue. In the event of a dryer malfunction or prolonged dryer shut down, it will turn gray in the presence of moisture.

8.2 FAILURE TO SHIFT ALARM (OPTIONAL)

The Failure to Shift Alarm provides an indication of switching failure in one of the dryer switching valves. The Fail to Shift Alarm uses a pressure switch to monitor the pressure in each tower. At "0" PSIG the switches are normally closed which sends a signal to the controller. When the towers pressurize, the switches open, thus removing the signal to the controller. The controller anticipates the appropriate open and closed switch position based on its timing sequence. If either switch is in an incorrect position, the alarm light will illuminate.

8.3 ENERGY MANAGEMENT SYSTEM (EMS) - (OPTIONAL)

Ingersoll Rand's EMS system is designed to minimize the loss of purge air during low flow or low water loading conditions. A digital dew point sensor is used to detect the actual outlet pressure dew point of the process air. The sensor communicates the pressure dew point reading to the Microprocessor Controller. The Microprocessor Controller interprets whether the outlet pressure dew point is above or at the EMS set point. As long as the outlet pressure dew point is dryer than the set point, the Microprocessor Controller will not allow the Purge Valves to open. The dryer will however, continue to cycle back and forth between towers. Once the EMS threshold is reached, the Microprocessor Controller will initiate the regeneration cycle and the appropriate Purge Valve will open.

NOTICE

At initial start-up or after desiccant changeout, the new desiccant has a moisture holding capacity higher than the dryer's design regeneration capabilities. The desiccant stabilizes to an "aged" state after three to six months of use. Ingersoll Rand recommends keeping the EMS feature off for one to two weeks from initial start-up or desiccant replacement. Activating the EMS after this period will insure proper operation of the EMS.

8.4 HIGH DEW POINT ALARM (INCLUDED WITH EMS)

The purpose of the High Dew Point Alarm is to provide the operator an alarm indication should the equipment fail to supply air at its designed pressure dew point. The EMS dew point sensor communicates the pressure dew point reading to the Microprocessor Controller. Should the pressure dew point rise above the alarm set point, the Microprocessor Controller will display the alarm condition on the controller screen.

8.5 COMPRESSOR INTERLOCK

Compressor Interlock adjusts the operation of the dryer to use purge air only when the air compressor is LOADING or ON. For installations with significant downstream air storage, this feature closes the purge valves if the compressor is not delivering flow after completion of the current tower purge cycle. This feature requires a relay (supplied by others) on the air compressor to indicate whether the air compressor is LOADING or ON vs. UNLOADING or OFF. Prior to using this feature, the relay must be wired to the 5V DC terminal strip in the dryer's electrical enclosure (refer to the appropriate wiring diagram). The dryer will provide the 5V DC power. For proper operation, the air compressor ON or LOAD signal should correspond with the relay being closed. The OFF or UNLOAD signal must correspond to the relay being open.

Adjusting the purge cycle to correlate with the operation of the air compressor minimizes the potential for the air compressor to cycle and saves the energy associated with generating unnecessary purge air.

9.0 INSTALLATION AND INITIAL START-UP

9.1 APPLICATION AND CHECK ANALYSIS

To achieve the best dryer performance, you should carefully check that the design and installation requirements outlined below are satisfied.

NOTICE

The standard dryer is not rated for any gas other than air.

Operating pressure of **Ingersoll Rand** dryers can range from 75 -150 PSIG. Air available for your usage will vary with operating pressure. The maximum design pressure of the **Ingersoll Rand** Heatless Dryer is 150 PSIG. For units required for higher operating pressures, consult your **Ingersoll Rand** representative.

The dryer must never be installed where air and/or ambient temperature exceeds 120°F or drops below +50°F. Locate dryer to avoid extremes of heat and cold from ambient or other conditions. Avoid locating dryer outside or where it is exposed to the elements.

NOTICE

Ingersoll Rand recommends that the mufflers be cleaned after initial start-up to remove any desiccant dust generated during shipment. After running dryer for initial 30 minute period, de-energize / depressurize dryer and remove mufflers. Disassemble and clean the removable insert inside the muffler core. Reinstall mufflers prior to operating dryer.

9.2 LOCATING AND MOUNTING

Lift the dryer only by the lifting points indicated by the lifting labels on the dryer.

If the dryer has been shipped with desiccant packaged separately, install the desiccant after locating and mounting. Desiccant has been provided separate to minimize handling difficulty and placing unnecessary stress on the dryer assembly

Bolt the dryer to the foundation using the bolt holes provided in the base frame. Anchor bolts should project a minimum of 3.5 inches above the foundation. Refer to General Arrangement drawing for details.

9.3 PIPING

Pipe the compressed air lines to the inlet and outlet connections. Locate the pre-filters as close as possible to the dryer. Ensure the positioning allows for ease of servicing. Refer to the General Arrangement drawing.

Note that the wet air inlet is at the dryer's lower manifold, while the dry air outlet is at the dryer's upper manifold. In situations where air supply is required 24 hours a day (it is

undesirable to interrupt the airflow), a three valve by-pass system is recommended to bypass the dryer. Use the fewest elbows necessary to keep pressure drop at a minimum.

Once all piping has been connected, all joints including those on the dryer, should be soap bubble tested at line pressure to ensure no joints have been damaged in transit and site placement.

9.4 FILTRATION

It is important that a pre-filter and an post-filter be provided in your dryer installation. All dryers are supplied with a pre-filter and post-filter as standard. They are mounted on the HL1200 and smaller. They are shipped loose on the HL1500 and larger.

NOTICE

All dryers must have proper filtration. A 1.0 micron coalescing filter with automatic drain & particulate after filter must be used as a minimum. Failure to provide proper filtration for dryer will void warranty.

Coalescing pre-filters, located before the dryer, protect desiccant beds from contamination by oil, entrained water, pipe scale, etc., thereby, extending dryer desiccant life. Locate pre-filters as close to dryer as possible.

It is recommended that a mechanical separator be installed immediately preceding the pre-filter to remove the bulk liquid and entrained water.

Particulate post-filters, located after the dryer, help eliminate the possibility of desiccant dusting and carryover into the air system.

9.4.1 AUTOMATIC DRAIN VALVE

Filters including the automatic float drain valve (24335028) must be placed vertically for proper operation.

Min. operating pressure is 22psig; pressures below 22psig will allow air to escape from the drain.

Turn the drain screw (18 in Figure 2 and direction shown in Figure 1):

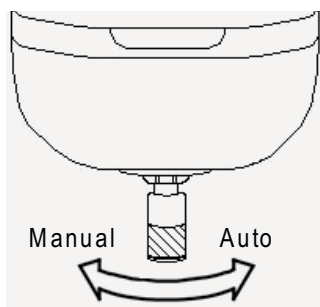

FIGURE 1

- Clockwise (when viewed from the bottom of the filter bowl) for AUTOMATIC draining of condensate.
- Counter-clockwise (when viewed from the bottom of the filter bowl) for MANUAL draining of condensate.

⚠ WARNING

Proper safety pre-cautions must be followed before servicing filters & drains. Filter bowl must be de-pressurized before servicing drain.

Service should only be performed by qualified personnel.

Before first-time use, and after maintenance, the drain screw (18) should be turned clockwise as far as it will go to provide automatic operation (Figure 1).

Method of Operation (See Figure 2)

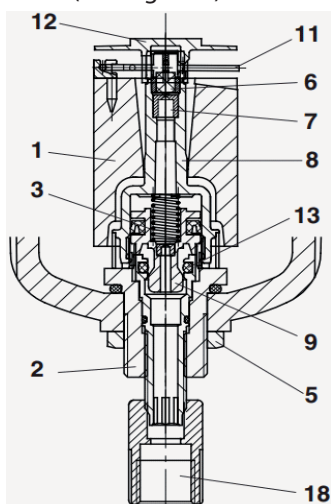

FIGURE 2

- When filter pressure is below 22psig, the piston (9) is held in an open position by the spring (3).
- When filter is pressurized above 22psig the piston closes the drain aperture at the O-ring (13).
- As the condensate collects in the filter, the float (1) is pushed upwards and opens the nozzle (7), allowing air to reach the top of the piston (9). This causes the piston to move downwards, opening the aperture at the O-ring (13) for drainage of the condensate.

Maintenance & Initial Operational Notes

- Inspect drain(s) after initial startup for system debris. Clean as required. Float drain assembly is screwed into bottom of bowl.
- Drains require periodic inspection and maintenance to ensure proper operation. Clogging of drains due to system debris or fouling are not considered warranty. Faulty drains must be returned back to the factory for analysis in order to receive proper warranty credit.

Clogged drain screens can be cleaned by immersing drain in a detergent.

9.5 DEW POINT TRANSMITTER INSTALLATION (OPTIONAL)

On dryers equipped with EMS, the dew point transmitter is shipped in a separate container within the electrical enclosure to protect the transmitter during shipment. Prior to using the EMS feature, the transmitter must be installed in the sensor block located on the side of or behind the electrical enclosure and the transmitter cable fastened to the sensor. Note that the transmitter should only be installed when the dryer is ready to be commissioned.

To install the Dew Point Transmitter:

- Remove Transmitter from original packaging.
- Verify that Washer is placed below Transmitter hex.
- Thread the Transmitter into the Sensor Block as shown.
- Attach the Transmitter Cable to the Transmitter. Be sure to fully engage the Transmitter Cable Securing Screw into the mating thread in the Transmitter.

9.0 INSTALLATION AND INITIAL START-UP

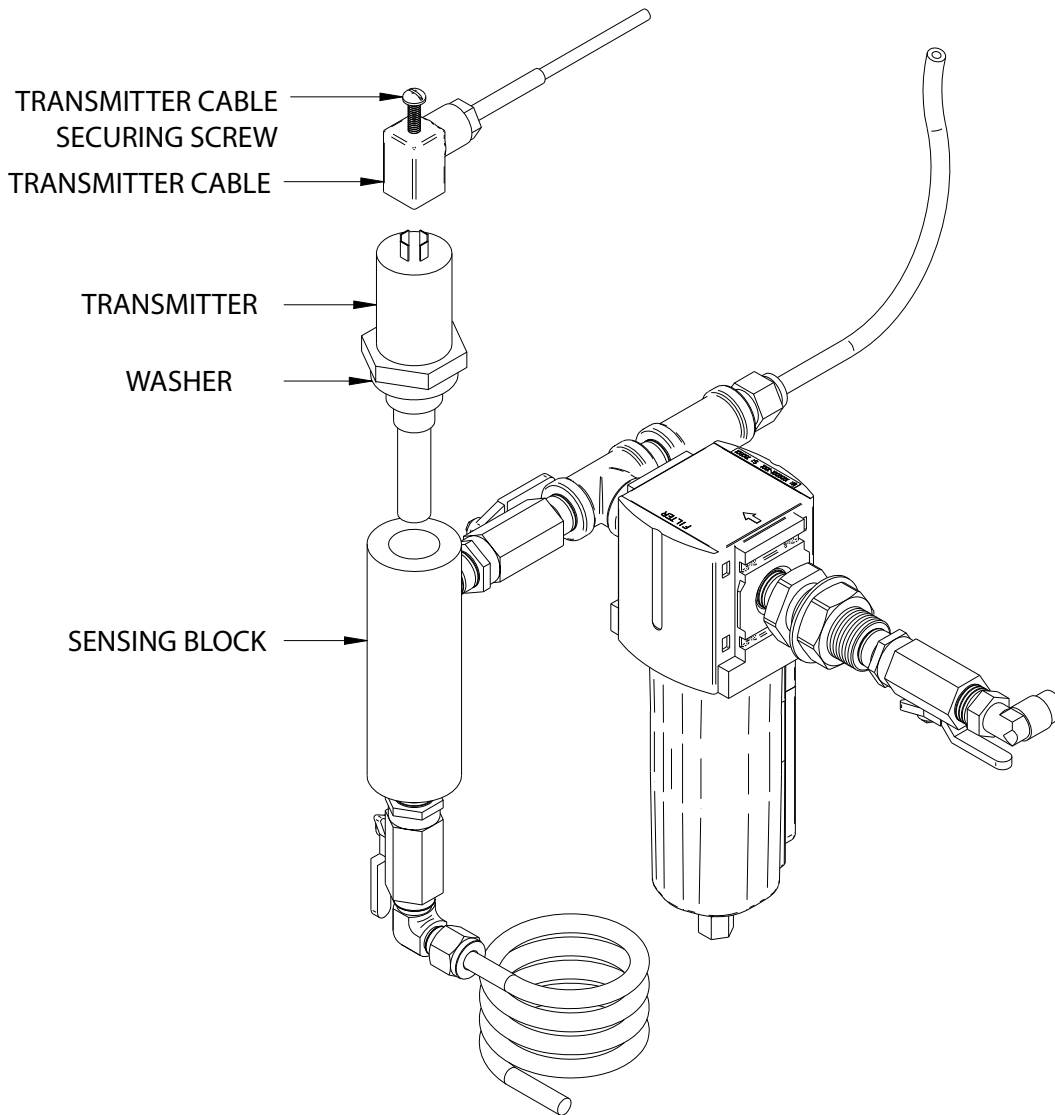

9.6 ELECTRICAL CONNECTION

Make all electrical connections to the dryer as shown on the wiring diagram. Care must be taken in connecting the proper voltages.

NOTICE

Dryer must be grounded with the full sized ground wire connected to an earth ground.

NOTICE

Dryer must be fused according to NEC with the size fuse listed on the dryer serial nameplate, or on specification sheet in technical manual.

Size field connection knock-out for the conduit fitting required by the NEC.

9.7 DESICCANT LEVEL VERIFICATION

Remove desiccant fill port and the top of the desiccant vessel and check desiccant level. The level should be consistent with the level depicted on the Desiccant Fill Chart at the end of the manual. The initial charge of desiccant is installed in the dryers at the factory on models HL 2700 and smaller.

9.8 START-UP

- Slowly pressurize the dryer. When the dryer reaches full operating pressure, check the system for air leaks. Soap test all joints and fitting. To maintain desired dew point, any leaks detected must be fixed, especially those on the outlet side of the dryer.
- Make sure that the purge adjustment valve is open and air outlet shut off valve (if equipped) is closed.

9.0 INSTALLATION AND INITIAL START-UP

- For dryers equipped with EMS, remove the dew point monitor sensor from the electrical enclosure and install in the sensing block, located beside the enclosure and attach the sensor cable to the sensor.
- Turn on dryer disconnect switch (supplied by customer) to apply power to the dryer. The LCD display on the Microprocessor Controller will illuminate.
- Start dryer by depressing the ON button on the Microprocessor Controller.
- For the first 30 seconds that the dryer is energized, both purge valves will remain closed. After 30 seconds, the left tower purge valve will be opened and depressurization of the left tower will occur.
- With a voltmeter, check the power connections for the correct voltage shown on the dryer serial nameplate.
- Close and secure all electrical panel covers.
- The Microprocessor Controller will indicate that the left tower is drying. The dryer will operate in the sequence described in Section 7.
- Following depressurization, adjust purge valve as described in Section 7.4

NOTICE

At initial start-up, check the dryer operation for one or two cycles, especially at the time of the tower shift. Verify that all systems are operating in their proper order and sequence. If the dryer is not functioning properly, contact distributor or Ingersoll Rand Technical Service.

- If the dryer has been in storage or off for an extended period of time, the Blue Moisture Indicator may be gray, the High Dew Point Alarm (if equipped) may be activated and the dew point display (if equipped) may indicate a high dew point. Depending upon the duration of idle time, it may take anywhere from one to twelve hours for the alarm condition to go out, the BMI to return to its normal blue state and the dew point to drop.
- Slowly open the outlet valve to gradually pressurize the down stream piping.

NOTICE

When opening the outlet valve, insure drying tower gauge maintains line pressure. Allowing pressure to drop in the dryer will result in an overflow condition.

NOTICE

-100° F dryers require flow through the dryer to lower the pressure dew point to design levels. Failure to permit air flow through dryer (deadheading) will result in elevated outlet dew points. Once air is permitted to flow through the dryer, the pressure dew point will gradually reduce to design levels.

9.9 SHUT-DOWN SEQUENCE

NOTICE

Prior to removing power or compressed air from the dryer, depress the OFF button on the Microprocessor Control This initiates the Shutdown Sequence, which closes the purge valves, repressurizes the off-line tower and opens the flow valves. DO NOT REMOVE POWER OR COMPRESSED AIR FROM THE DRYER DURING THE SHUTDOWN SEQUENCE.

- Maintain a compressed air source to the dryer and a supply of power to the Microprocessor Controller.



SHUTDOWN
SEQUENCE

Depress the OFF button to initiate the SHUTDOWN SEQUENCE.

- Permit the dryer to complete the full SHUTDOWN SEQUENCE (30 seconds)

PRESS ON

Once the PRESS ON Prompt is displayed, the dryer has completed the SHUTDOWN SEQUENCE. Power and air may be safely removed from the dryer.

- De-energize the dryer
- Shut down air compressor or bypass dryer
- Close Isolation Valves (if equipped)

Note: On the subsequent Start-up, the outlet isolation valve should be in the closed position. Slowly open the valve to build pressure downstream.

10.0 TECHNICIAN MODE

The Microprocessor Control provides a protected TECHNICIAN MODE to manipulate several parameters not accessible by the casual operator. Below is a list of parameters that can be accessed and manipulated by the technician in the TECHNICIAN MODE:

Parameter	Display	Set Point
DEW POINT ADJUSTER SETTING	PDP ADJUSTER	-40, -4, +38
ENERGY MANAGEMENT SYSTEM (OPTIONAL)	EMS	OFF , ON
ENERGY MANAGEMENT SYSTEM SETPOINT (OPTIONAL) *	EMS SET POINT	-76 - +68
RESTART MODE	RESTART	LAST, ZERO
PURGE FLOW ADJUSTER SETTING	PURGE ADJUSTER	30% - 100%
COMPRESSOR INTERLOCK SETTING	COMP INTERLOCK	OFF , ON
HIGH DEW POINT ALARM ACTIVATION (OPTIONAL)	HIGH DEW POINT	OFF , ON

In TECHNICIAN MODE, the following parameters can be viewed but not changed:

Parameter	Display
OPERATION MODE	HEATLESS

* NOTE: Setpoints indicated are adjustable ONLY when dryer is equipped with the EMS. Setpoints are non-adjustable on dryers without this option

10.1 ENTERING TECHNICIAN MODE

⚠ WARNING

TECHNICIAN MODE should only be entered by qualified service personnel. Altering the set points in TECHNICIAN MODE will have a significant effect on the operation of the dryer. Incorrect set points may damage dryer and cause potential serious injury.

To enter the TECHNICIAN MODE, perform the following keystrokes:



Pressing the "2" and "3" buttons simultaneously enters the TECHNICIAN MODE.



Depressing SELECT DISPLAY scrolls through the available parameters.

10.2 DEW POINT ADJUSTER (-40 °F DRYERS ONLY)

Dew point adjuster allows the user to select between -40 °F, -4 °F and +38°F pressure dew points. Selecting a higher (wetter) pressure dew point lengthens the drying cycle, making the regeneration process commence less frequently than at lower (drier) dew points. This results in energy savings by depressurizing the system less times per hour. The chart below describes the available outlet pressure dew points that may be selected along with their respective cycle times.

ISO 8573.1 Class	Pressure Dew Point		Cycle Length	Regenerations per hour
2	-40 °F	-40 °C	10 min	12
3	-4 °F	-20 °C	16 min	7.5
4	+38 °F	+3 °C	24 min	5

The following illustrates the method of accessing and adjusting the dew point adjuster feature

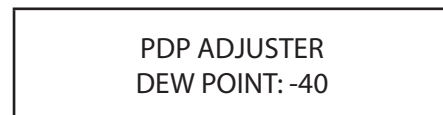

Press the SELECT DISPLAY button until the DEW POINT ADJUSTER screen is displayed.

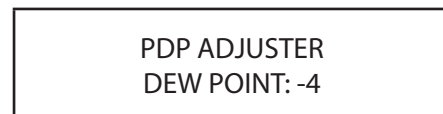

Depress the +/- button until the desired dew point is displayed. Pressing SELECT DISPLAY saves the current selection.

10.3 ENERGY MANAGEMENT SYSTEM (OPTIONAL)

10.3.1 DESCRIPTION AND ACTIVATION

The optional Energy Management System (EMS) feature is designed to minimize the loss of purge air during low flow or low water loading conditions. A digital dew point sensor detects the actual outlet air pressure dew point of the process air.

10.0 TECHNICIAN MODE

The sensor communicates the pressure dew point reading to the Microprocessor Controller. Should the pressure dew point be below the EMS set point, the Microprocessor Controller will keep the purge valves closed while the dryer continues to cycle back and forth between towers, thereby saving purge air.

The following illustrates the method of accessing and adjusting the Energy Management System feature:



Depress the SELECT DISPLAY button until the ENERGY MANAGEMENT SYSTEM screen is displayed.

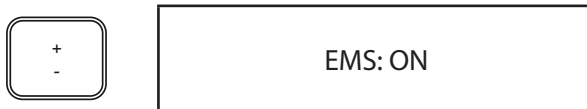

Depress the +/- button until the desired set point is displayed. Pressing SELECT DISPLAY saves the current selection.

10.3.2 SETPOINT ADJUSTMENT

On dryers equipped with the optional EMS, the Energy Management System setpoint can be adjusted to match the dryers requirements to the desired pressure dew point.

The following illustrates the method of adjusting the setpoint for the Energy Management System feature:



Depress the SELECT DISPLAY button until the EMS SET POINT screen is displayed.



Pressing the SET button permits the value of the EMS SETPOINT to be changed



To enter a negative number, depress the +/- button. Otherwise, proceed to the next step.



Use the numbers on the keypad to enter the desired pressure dew point temperature for the EMS setpoint.



Use the numbers on the keypad to enter the desired pressure dew point temperature for the EMS setpoint.



Depressing ENTER saves the selected set point.

NOTICE

The Energy Management System set point should not be lower (wetter) than the dew point adjuster setting. Failure to do so will prevent the Energy Management System feature from operating. In addition, when operating in EMS, the purge flow adjuster should be set to 100%.

10.4 RESTART MODE

HL Dryers can be configured to restart in one of two operating modes. As described in Section 5, the dryer may be configured for Manual operation (factory default) or Auto Restart, which permits the dryer to restart automatically once power is re-applied to the dryer. The following illustrates the method of accessing and adjusting the different start modes for the dryer:



Depress the SELECT DISPLAY button until the START MODE screen is displayed.

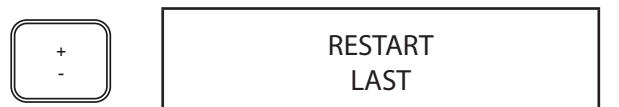

To change the start mode from its current selection to the alternate setting, depress the +/- button until the desired set point is displayed. Pressing SELECT DISPLAY saves the current selection.

10.5 PURGE FLOW ADJUSTER

Purge flow adjuster allows the user to reduce the duration of the purge cycle to more closely match the inlet conditions

10.0 TECHNICIAN MODE

to the dryer. This feature is well suited for applications where the dryer is consistently underflowed, allowing only the required amount of purge air to be used. The purge flow adjuster feature allows the user to select the relative duration of the purge cycle, from 30% to 100%, in 10% increments.

The following illustrates the method of accessing and adjusting the purge flow adjuster feature



PURGE ADJUST
% PRG SELECT 100

Depress the SELECT DISPLAY button until the PURGE FLOW ADJUSTER screen is displayed.



PURGE ADJUST
% PRG SELECT 70

Depress the +/- button until the desired percent purge is displayed. Pressing SELECT DISPLAY saves the current selection.

NOTICE

On dryers equipped with the optional Energy Management System feature, the purge flow adjuster MUST be set to 100% in order for the Energy Management System to operate properly.

10.6 COMPRESSOR INTERLOCK

Compressor Interlock adjusts the operation of dryer to purge only when the air compressor is LOADING or ON. This feature requires the customer to provide a relay on the air compressor to indicate whether the air compressor is LOADING or ON vs. UNLOADING or OFF. Prior to using this feature, the user must wire the relay to the 5V DC terminal strip in the dryer's electrical enclosure. The dryer will provide the 5V DC power. The air compressor ON or LOAD signal should correspond with the relay being open. The OFF or UNLOAD signal must correspond to the relay being closed.

With the Compressor Interlock properly set-up and activated, the dryer's purge valves will close when the air compressor is not making air, as indicated by the OFF or UNLOAD condition. With the purge cycle corresponding to the demands of the air dryer, cycling of the air compressor is minimized and energy savings is realized by only purging when the air system requires.

The following illustrates the method of accessing and adjusting the Compressor Interlock feature:



COMP INTERLOCK
OFF

Depress the SELECT DISPLAY button until the COMPRESSOR

INTERLOCK screen is displayed.



COMP INTERLOCK
ON

Depress the +/- button until the desired set point is displayed. Pressing SELECT DISPLAY saves the current selection.

10.7 HIGH DEW POINT ALARM (INCLUDED WITH EMS OPTION)

10.7.1 DESCRIPTION AND ACTIVATION

The purpose of the High Dew Point Alarm is to provide the operator an alarm indication should the equipment fail to supply air at its designed pressure dew point. The EMS dew point sensor communicates the pressure dew point reading to the Microprocessor Controller. Should the pressure dew point rise above the alarm set point, the Microprocessor Controller will display the alarm condition on the controller screen.

The following illustrates the method of activating the High Dew Point Alarm feature:



HIGH DEW PT
OFF

Depress the SELECT DISPLAY button until the HIGH DEW POINT screen is displayed.

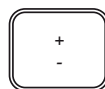

HIGH DEW PT
ON

Depress the +/- button until the desired set point is displayed. Pressing SELECT DISPLAY saves the current selection.

10.7.2 SETPOINT ADJUSTMENT

On dryers equipped with the optional EMS, the High Dew Point Alarm setpoint can be adjusted.

The following illustrates the method of adjusting the setpoint for the High Dew Point Alarm feature:



HI PDP SETPOINT
-10

Depress the SELECT DISPLAY button until the HIGH DEW POINT ALARM SET POINT screen is displayed.

10.0 TECHNICIAN MODE



HI PDP SETPOINT
—

Pressing the SET button permits the value of the HIGH DEW POINT ALARM SET POINT to be changed.



HI PDP SETPOINT
-21

Depressing ENTER saves the selected set point.

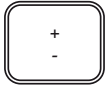

HI PDP SETPOINT
-__

To enter a negative number, depress the +/- button. Otherwise, proceed to the next step.



HI PDP SETPOINT
-2__

Use the numbers on the keypad to enter the desired pressure dew point temperature for the HIGH DEW POINT ALARM setpoint.



HI PDP SETPOINT
-21_

Use the numbers on the keypad to enter the desired pressure dew point temperature for the HIGH DEW POINT ALARM setpoint.

NOTICE

The High Dew Point Alarm set point should not be greater than the Energy Management System set point or the dew point adjuster setting. Failure to do so will result in an alarm indication. Ingersoll Rand recommends setting the High Dew Point Alarm at least 10°F wetter than the Energy Management System or dew point adjuster setpoints.

NOTICE

To exit the TECHNICIAN MODE, press the "+ / -" key to the initial "SETOPMODE" screen and depress the ↵ button to return to the CUSTOMER MODE.

Ingersoll Rand desiccant dryers are capable of remote communications via MODBUS. Refer to the document entitled, "Microprocessor Control Modbus Communications Guide" for details on communicating with the Controller via MODBUS.

11.0 MAINTENANCE AND SYSTEM CHECK

11.1 SCHEDULED MAINTENANCE

DAILY MAINTENANCE FUNCTIONS:

- Check and record inlet pressure, temperature and flow. Verify that it is within specifications.
- Check tower pressure gauge readings within operating tolerance.
- Check operation for proper dryer cycling, depressurization and repressurization.
- Check that the pre-filter drain is operating properly and that there is no condensate discharged from purge mufflers. Replace cartridges sooner if necessary as required by differential pressure indicator.
- Verify that pressure in purging tower is 10 PSIG or less. If higher, muffler replacement is recommended. (Section 11.4)
- Verify that pre-filter and post-filter differential pressure is within operating limits. Change as required. (Section 11.2). Replace cartridges sooner if necessary as required by differential pressure indicator.
- Check the Blue Moisture Indicator. Make sure air is bleeding through the indicator. The indicator will be blue when air is dry.

SEMI-ANNUAL MAINTENANCE FUNCTIONS:

- Check outlet dew point.
- Check pilot air filter element and clean or replace as required.
- Replace pre-filter and post-filter elements and / or cartridges. Replace cartridges sooner if necessary as required by differential pressure indicator.

ANNUAL MAINTENANCE FUNCTIONS:

- Check desiccant and replace if necessary.
- Inspect and clean pilot air control no-loss drain valves, check valves and diaphragm valves. Rebuild and / or replace as required.
- Test lights and switches, replace as necessary.
- Test electrical components, replace as necessary.

EVERY TWO YEARS:

- Replace diaphragm and seal kits on purge and switching diaphragm valves.

EVERY THREE - TO - FIVE YEARS:

- Replace desiccant.
- Rebuild purge and switching diaphragm valves (Preventative)
- Replace Check Valves (Preventative)

11.2 PRE-FILTERS AND POST-FILTERS

- Pre-filters - The cartridges of the pre-filter must be changed as often as required to prevent contamination of the regenerative dryer's desiccant bed.

The pre-filter and automatic drain must be checked daily. To prolong filter cartridge life, it is recommended that a mechanical air / moisture separator be placed immediately before the pre-filter.

NOTICE

Should the drying system be overloaded and/or malfunctioning, causing high pressure drop, post-filters will prematurely plug. This problem can be avoided by frequent inspection and proactive replacement of cartridges.

- Post-filters - The purpose of the post-filter is to remove residual desiccant dust. Depending upon equipment application and usage, frequency of filter element change will vary. It is recommended to change filter element every six months as a minimum.



WARNING

To avoid injury, depressurize dryer before performing any service.

11.0 MAINTENANCE AND SYSTEM CHECK

11.2.1 FLANGED FILTERS:

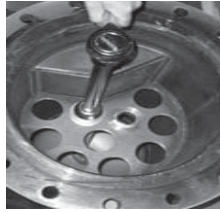

STEP 1 - Using a 2" socket with an extension, carefully loosen element.



STEP 2 - Remove old element from filter housing.



STEP 3 - Install new element by carefully inserting element in top plate.



STEP 4 - Hand tighten element in place until element o-ring contacts top plate.



STEP 5 - Using a 2" socket with an extension, tighten element one half turn. DO NOT OVERTIGHTEN.



STEP 6 - Repeat procedure as required to replace all elements.

11.3 PILOT AIR CONTROL NO-LOSS DRAIN VALVES

The length of time the pilot air valves can reliably operate without replacing is dependent upon the type of dryer and the dryer's operation. On **Ingersoll Rand** -40°F dew point dryers, replacing the valves is recommended every 60 months. Given the difference in cycle times for -100°F units, these dryers should have their pilot valves replaced every 30 months.

11.4 MUFFLER CHANGEOUT PROCEDURE

⚠ WARNING

To avoid injury, depressurize dryer before performing any service.

- Depressurize the dryer turn control power off.
- Replace muffler.
- Follow Start-up procedure described in Section 9.7.
- Turn control power back on.

11.5 PURGE AND SWITCHING DIAPHRAGM VALVES (HL800 - HL 2700)

These valves have two control ports; one on top and the other on the back side.

- Normally Open (N.O.) Valves: For N.O. inlet or repressurization valves, control air is supplied to the top port. The back side port exhausts out the bottom side of the diaphragm. If air leaks continuously when control air is supplied to the valve, the internal seals are leaking and must be replaced.
- Normally Closed (N.C.) Valves: For N.C. purge valves, the top port is plugged. Control air is supplied to the back port. If air vents out of the back port continuously when the solenoid is de-energized, it will exhaust through the top of the solenoid. If this condition is observed, the internal seals are leaking and must be replaced.

11.6 PILOT OPERATED ACTUATOR (HL3300 - HL5000)

Should the actuator fail to rotate, disconnect the pilot lines to check if the actuator is receiving pilot pressure.

If the actuator is receiving pressure:

- Verify that control pressure is 75 psig min.
- Ensure the inlet valve is not plugged.

11.7 OUTLET CHECK VALVES

Outlet check valves sealing can be verified by depressurizing the dryer and slowly applying pressure to the outlet. The valves should seal and prevent air from pressurizing the towers. If a tower begins to pressurize, the check valve on that side requires replacement.

11.0 MAINTENANCE AND SYSTEM CHECK

11.8 DESICCANT CHANGEOUT PROCEDURE

When it becomes necessary to replace the desiccant in the towers, observe the following procedure:

WARNING

To avoid injury, depressurize dryer before performing any service.

CAUTION

Be sure to wear respiratory protection during the draining and filling process to minimize inhalation of desiccant, as desiccant will produce dust during this procedure.

NOTICE

Each dryer is shipped with a desiccant sample kit to allow the desiccant to be sent for analysis. This kit can be used to have the condition of the desiccant verified by laboratory analysis. Please follow the instructions found in the kit.

- The standard units are furnished with fill and drain ports on each desiccant tower. Remove the caps on both ports.
- To assist in getting the desiccant to flow from the tower, insert a small rod in to the drain port as necessary. This may be required as the desiccant is packed into the towers which may interfere with the desiccant flow from the towers.
- Retainer screens, located at the inlet and outlet piping connections of the tower, are removable on all models. It is suggested that these screens be removed and cleaned at the time of desiccant changeout. These screens can be accessed by disconnecting the upper and lower manifolds from the dryer towers.
- After cleaning the retainer screens, replace screens and reattach the outlet port plug.
- With the fill port plug removed, fill the dryer tower with the appropriate grade and size desiccant. The level of the desiccant should be below the top retainer screen as shown on the Desiccant Fill Chart below.
- Once the towers have been filled, replace the fill port plug on each tower.
- Any connections disturbed in the desiccant changeout process should be leak tested prior to re-commissioning the dryer.

11.0 MAINTENANCE AND SYSTEM CHECK

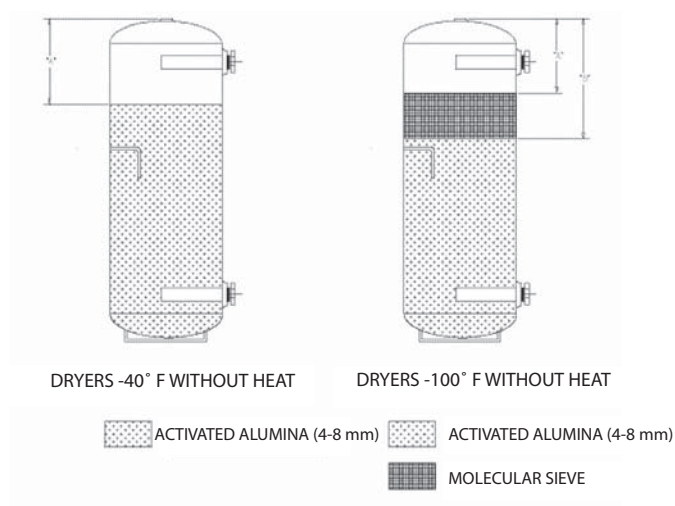

Model No.	A	B
HL800	34"	41"
HL1000	23"	31.5"
HL1200	10"	23.75"
HL1500	12"	23.25"
HL1800	35"	45.75"
HL2100	25.5"	38.5"
Tolerance = +/- .50"		

DESICCANT FILL CHART

MODEL No.	LB. AA -40°F DRYERS	LB. AA -100°F DRYERS	LB. MS -100°F DRYERS
HL800	900	675	225
HL1000	1100	825	275
HL1200	1270	953	318
HL1500	1600	1200	400
HL1800	2000	1500	500
HL2100	2340	1755	585
HL2700	2928	2196	732
HL3300	3800	2850	950
HL4000	4226	3200	1026
HL5000	5138	3850	1288

DESCRIPTION	PART #
ACTIVATED ALUMINA QTY. (1) 50 LB. BAG	38004834
ACTIVATED ALUMINA QTY. (42) 50 LB. BAGS	38004933
ACTIVATED ALUMINA QTY. (1) 2000 LB. SACK	38340659
MOLECULAR SIEVE QTY. (1) 275 LB. DRUM	38449971

AA = ACTIVATED ALUMINA
MS = MOLECULAR SIEVE

NOTE: Qty. is per dryer

11.0 MAINTENANCE AND SYSTEM CHECK

11.9 SCHEDULED MAINTENANCE, SYSTEM CHECK

Dryer Function	Action	Service Time Interval	
		Daily	Semi-Annually
Inlet Pressure, Temperature and Flow	Check	•	
Tower Pressure Gauge Readings	Check	•	
Proper Cycling	Check	•	
Proper Depressurization & Repressurization	Check	•	
Pre-Filter Drain Operating Properly	Check	•	
No Condensate Being Discharged from Purge Mufflers	Check	•	
Pressure in Purge Tower is 10 PSIG or Less	Check	•	
Pre-Filter and Post-Filter dP is Within Operating Limits	Check	•	
Air Bleeding Through the Blue Moisture Indicator	Check	•	
Outlet Dew Point	Check		•
Purge Air Filter Element	Replace		•
Pre-Filter Elements	Replace		•
Post-Filter Elements	Replace		•

11.0 MAINTENANCE AND SYSTEM CHECK

11.10 SCHEDULED MAINTENANCE, MAINTENANCE CHART

Dryer Component	Action	Service Time Interval (Year)														
		1	2	3	4	5	6	7	8	9	10	11	12	13	14	15
Desiccant (Analysis Kit CCN 38035119)	Analysis	•	•	•	•	•	•	•	•	•	•	•	•	•	•	•
Purge Muffler	Replace	•	•	•	•	•	•	•	•	•	•	•	•	•	•	•
Control Air Muffler	Replace	•	•	•	•	•	•	•	•	•	•	•	•	•	•	•
ENL Drain, Service Unit or Wearing Parts Kit	Replace	•	•	•	•	•	•	•	•	•	•	•	•	•	•	•
PNLD Drain, Clean Thoroughly	Clean	•	•	•	•	•	•	•	•	•	•	•	•	•	•	•
Diaphragm and Butterfly Valves	Inspect	•	•	•	•	•	•	•	•	•	•	•	•	•	•	•
Lights and Switches	Test	•	•	•	•	•	•	•	•	•	•	•	•	•	•	•
Electrical Components	Test	•	•	•	•	•	•	•	•	•	•	•	•	•	•	•
Dew Point Transmitter (EMS Option Only)	Replace	•	•	•	•	•	•	•	•	•	•	•	•	•	•	•
Air Leaks, Loose Bolts, Flanges, Fittings	Repair	•	•	•	•	•	•	•	•	•	•	•	•	•	•	•
Diaphragm Valves (Seal Kit)	Rebuild		•		•		•		•		•		•		•	
Purge Check Valves	Replace		•		•		•		•		•		•		•	
Control Air Solenoid Valve	Replace		•		•		•		•		•		•		•	
Blue Moisture Indicator	Replace		•		•		•		•		•		•		•	
Purge/Tower Pressure Gauge	Replace		•		•		•		•		•		•		•	
Purge Air Operated Valve	Replace			•		•			•			•			•	
Desiccant	Replace	Replace every 3-5 years														
Desiccant Screen Retainer Assembly	Replace	Replace during desiccant change-out														
Diaphragm Valves:																
Service Option: Hardware Kit	Rebuild					•					•					•
Replacement Option: Entire Valve	Replace					•					•					•
Butterfly Valves:																
Service Option: Valve Repair Kit	Rebuild					•					•					•
Service Option: Actuator Repair Kit	Rebuild					•					•					•
Replacement Option: Entire Valve	Replace					•					•					•
Replacement Option: Entire Actuator	Replace					•					•					•
Panel Display Board	Replace					•					•					•
Power Supply	Replace					•					•					•
Controller Overlay	Replace					•					•					•
Dew Point Sample Block (EMS Option Only)	Replace					•					•					•
Transmitter Cable (EMS Option Only)	Replace					•					•					•
Control Air Ball Valve	Replace					•					•					•
Purge Ball Valve	Replace					•					•					•
Safety Relief Valve	Replace					•					•					•
5V Load Resistor	Replace					•					•					•

12.0 TROUBLESHOOTING

Refer to maintenance descriptions in Section 11 as required for trouble shooting procedures.

PROBLEM	PROBABLE CAUSE	CORRECTIVE ACTION
Elevated dew point	Insufficient purge rate	Check purge flow settings. Check purge piping for obstruction. Clean purge piping and muffler.
	Inlet air pressure below design condition.	Check pressure source and system for leakage.
	Flow rate higher than design condition.	Check flow rate and cause for increased demand. Correct flow rate condition.
	Inlet temperature above design condition (120°F).	Check aftercooler, clean and service as necessary.
	Entrained water entering desiccant bed.	Check air/moisture separator and pre-filter. Replace dryer desiccant if necessary.
	Desiccant contaminated by oil.	Install suitable pre-filter. Replace dryer desiccant.
Blue Moisture Indicator (BMI) indicates high moisture level.	Elevated dew point	Refer to "Elevated Dew Point" corrective actions above.
	BMI wet	Depending on degree of saturation of the desiccant, the BMI may take a week or more of continuous use to switch back to its blue (dry) state.
Excessive pressure drop in dryer	Excessive flow rate.	Check flow rate and cause for increased air demand.
	Inlet pressure below design condition.	Check pressure source.
Failure to Shift (Switching Failure)	No input power	Check power input.
	Defective solenoid valve	Check solenoid valve.
	No pilot air	Check pilot air line. Check that control air line filter is clean.
	Pilot-operated diaphragm valve seal failure	Inspect and replace seals as required.
Dryer fails to pressurize.	Faulty purge valve	Check that repressurization circuit is sending control signal.
		Check purge valve and its solenoid valve.
Dryer depressurizes too rapidly.	Purge valve does not close; dryer repressurizing through inlet valve.	Check purge valve and its solenoid valve.
Dryer fails to purge.	Purge valve does not open. Purge valve stuck in closed position.	Check purge valve and its solenoid valve. Repair and replace if necessary.
		Check that repressurization circuit is sending control signal.
Excessive back pressure in regenerating tower (above 5 psig)	Purge muffler does not pass air.	Purge muffler is dirty; replace.
	Purge muffler passes too much air. Air is leaking across valve.	Check inlet valve and outlet check valves. Verify inlet valve is closed to purging tower (0 psig tower).
Right tower excessively high pressure at the purge gauge.	Improper calibration.	Reset when right tower is on line.

13.0 PURGE CHARTS

Purge Orifice - 7/16"
HL800 Setting - 46 psig @ 130 SCFM

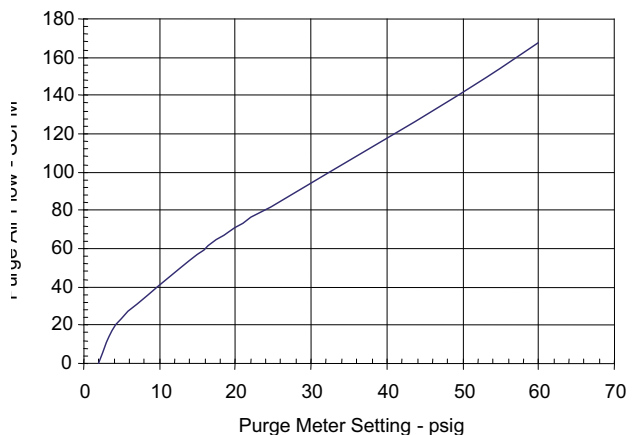

Purge Orifice - 1/2"
HL1000 Setting - 43 psig @ 162 SCFM

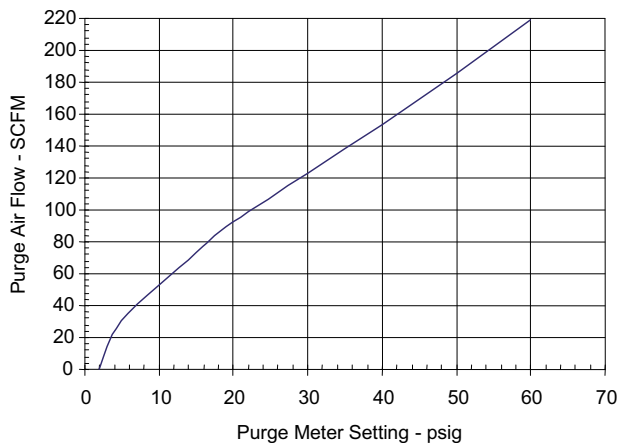

Purge Orifice - 9/16"
HL1200 Setting - 41 psig @ 195 SCFM

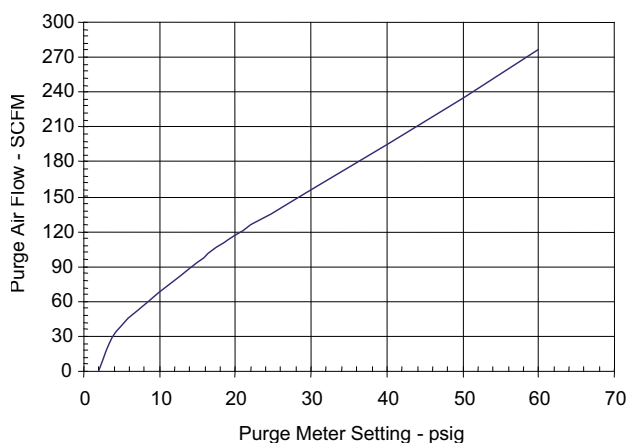

Purge Orifice - 5/8"
HL1500 Setting - 41 psig @ 243 SCFM

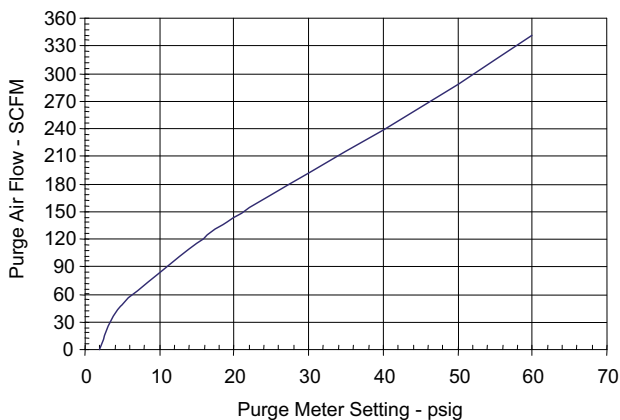

Purge Orifice - 5/8"
HL1800 Setting - 51 psig @ 292 SCFM

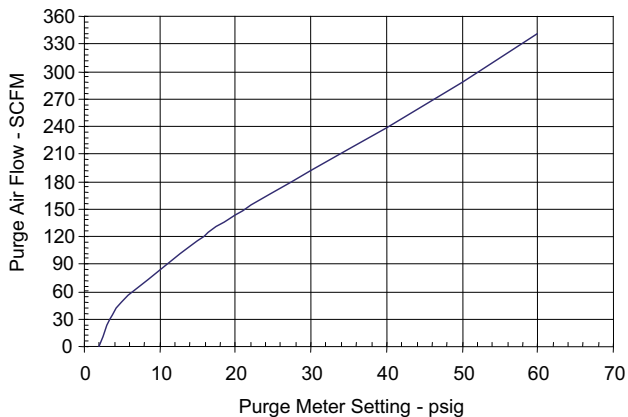

Purge Orifice - 3/4"
HL2100 Setting - 40 psig @ 340 SCFM

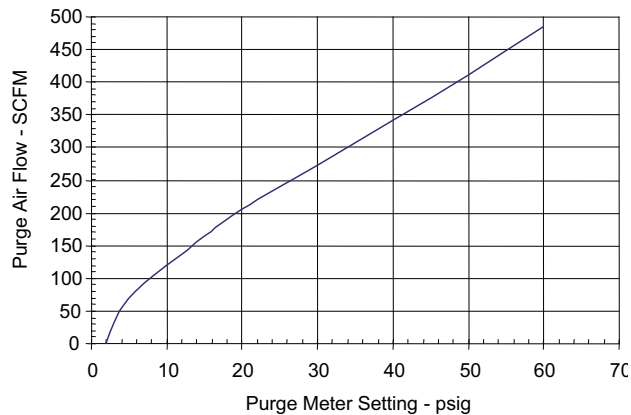

13.0 PURGE CHARTS

Purge Orifice - 3/4"
HL2700 Setting - 53 psig @ 438 SCFM

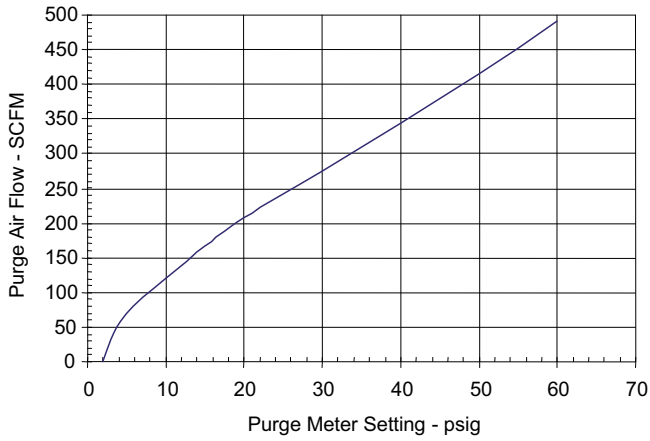

Purge Orifice 7/8"
HL3300 Setting - 47 psig @ 535 SCFM

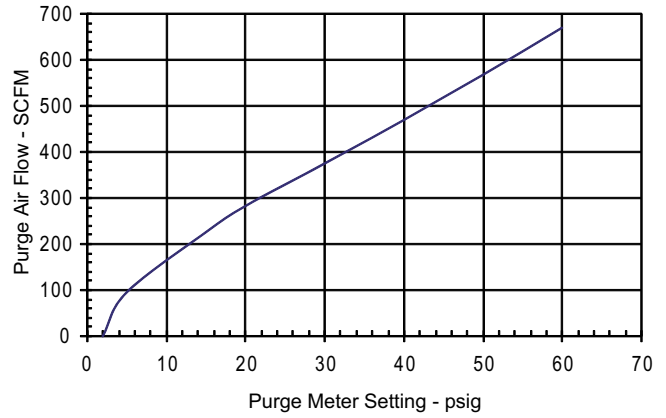

Purge Orifice - 1"
HL4000 Setting - 44 psig @ 649 SCFM

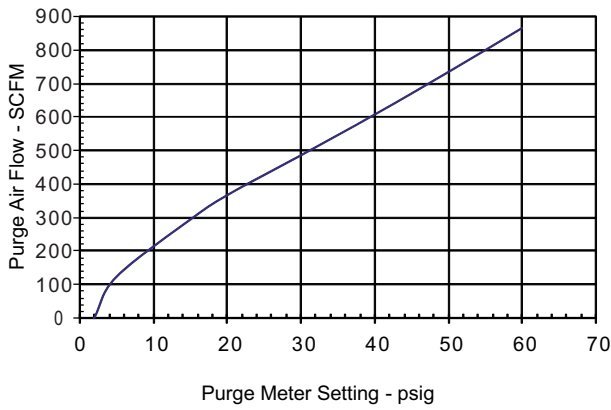

Purge Orifice - 1"
HL5000 Setting - 56 psig @ 811 SCFM

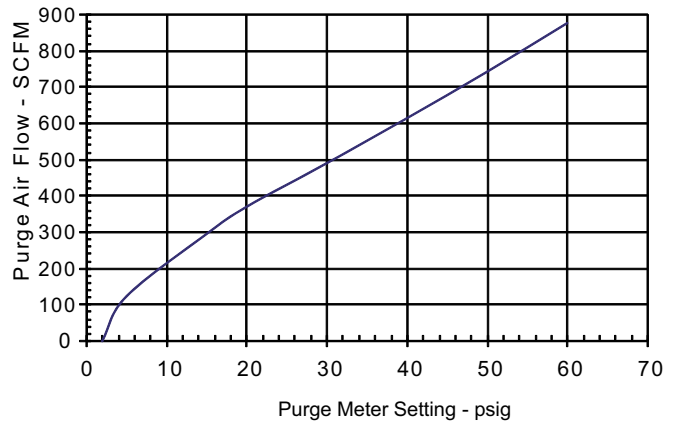

14.0 GENERAL ARRANGEMENT

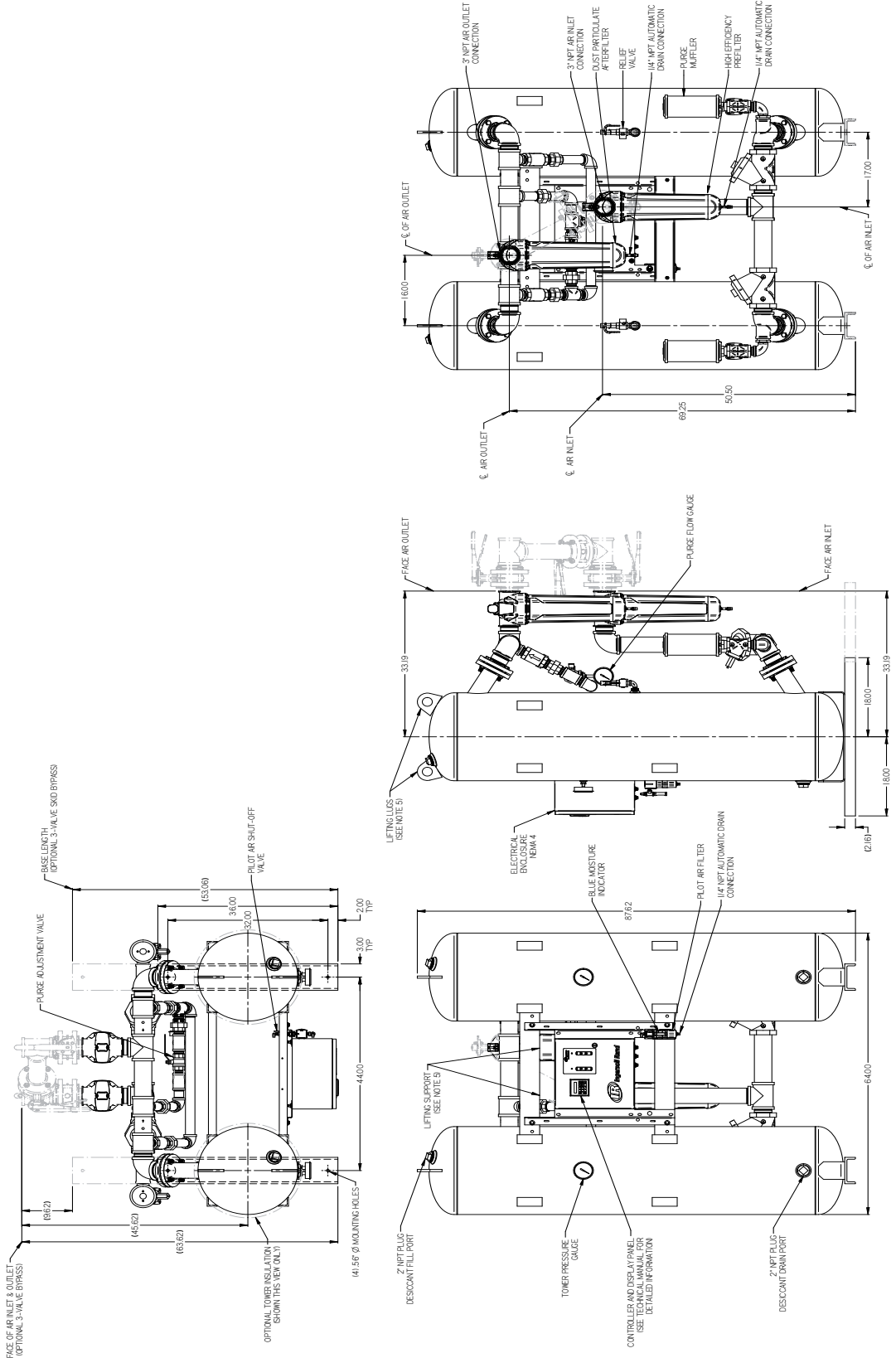

GENERAL ARRANGEMENT
HL800-HL1200
580005-J

- NOTES
- 1) MINIMUM WORKING PRESSURE - 150 PSIG
 - 2) SAFETY RELIEF VALVE SETTING - 165 PSIG
 - 3) PIPING AIR LINES NOT SHOWN FOR CLARITY
 - 4) PURGE MUFFLER IS AN OPTIONAL ELECTRICAL CODES LATEST EDITION
 - 5) ORDER TUBE LIFTED BY LIFTING LUGS SUPPORT ONLY
 - 6) DESIGN IS DELETED FOR STANDARD MODEL. THIS DRAWING DOES NOT DEPICT OPTIONS
 - 7) THE UNIT DIMENSIONS WILL VARY FOR PRODUCTS CONFIGURED WITH OPTIONS
 - 8) THIS DRAWING PROVIDES DIMENSIONS FOR THE FACE OF THE UNIT. CENTERED DIMENSIONS CAN BE PROVIDED UPON REQUEST.
 - 9) THE LOCATION OF COMPRESSED AIR INLET & OUTLET CONNECTIONS MAY VARY BASED ON OPTIONS SELECTED.

14.0 GENERAL ARRANGEMENT

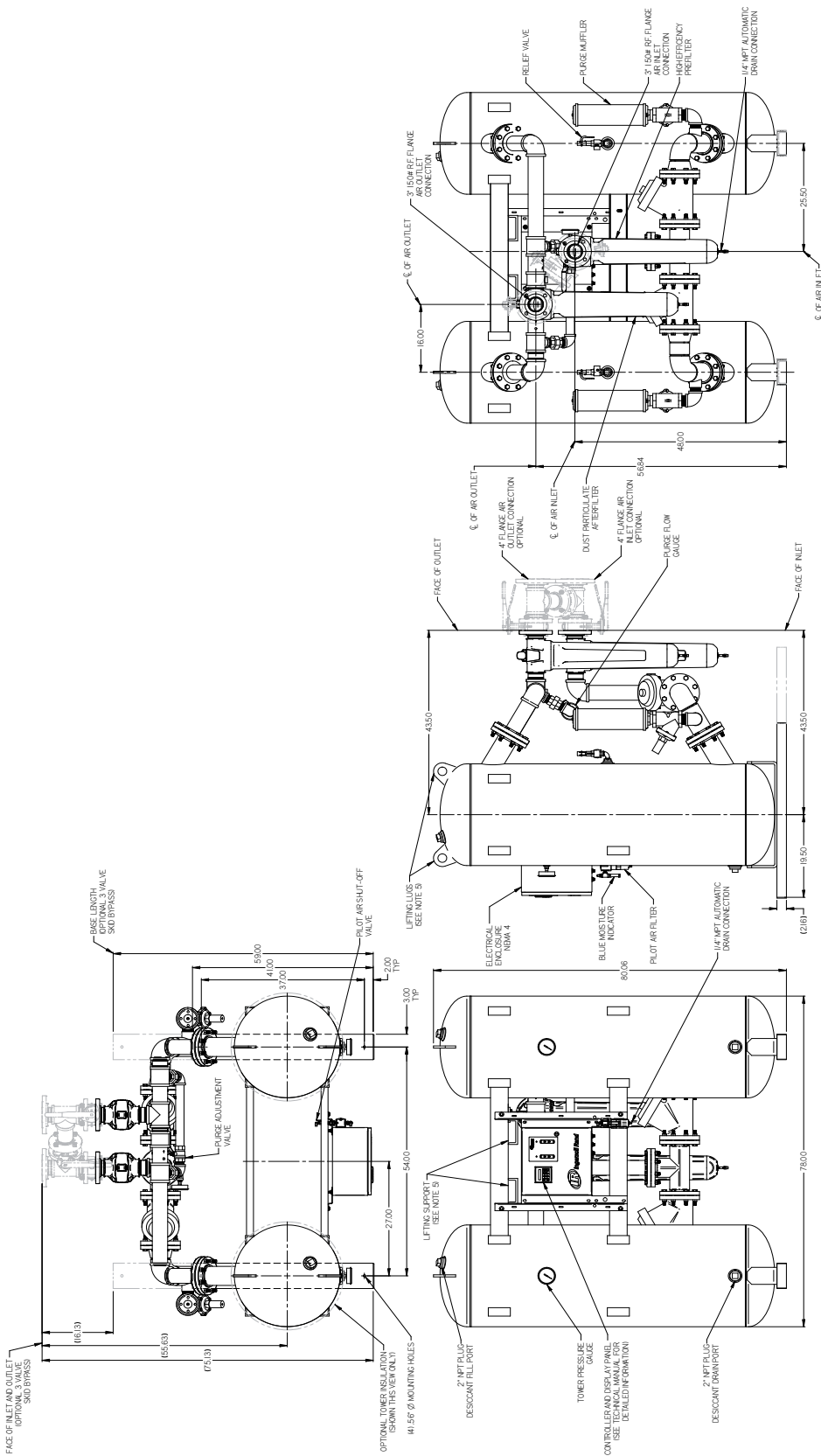

GENERAL ARRANGEMENT
HL1500
NEMA 4 W/DPC & FILTER PACKAGE 'A'
581288-B

- NOTES:**
1. MAXIMUM WORKING PRESSURE - 150 PSI
 2. SAFETY RELIEF VALVE SETTING - 165 PSI.
 3. PILOT AIR LINES NOT SHOWN FOR CLARITY.
 4. ELECTRICAL CONNECTIONS TO BE MADE TO THE ELECTRICAL CODES LATEST EDITION.
 5. PRIOR TO BE LIFTED BY LIFTING LUGS, SUPPORT ONLY.
 6. DESIGN IS DEPICTED FOR STANDARD MODEL. THIS DRAWING DOES NOT DEPICT OPTIONS.
 7. DIMENSIONS ARE IN INCHES UNLESS OTHERWISE SPECIFIED.
 8. THIS DRAWING IS PROVIDED FOR REFERENCE PURPOSES ONLY. CERTIFIED DRAWINGS CAN BE PROVIDED UPON REQUEST.
 9. LOCATION OF COMPRESSED AIR INLET & OUTLET CONNECTIONS MAY VARY BASED ON OPTIONS SELECTED.

14.0 GENERAL ARRANGEMENT

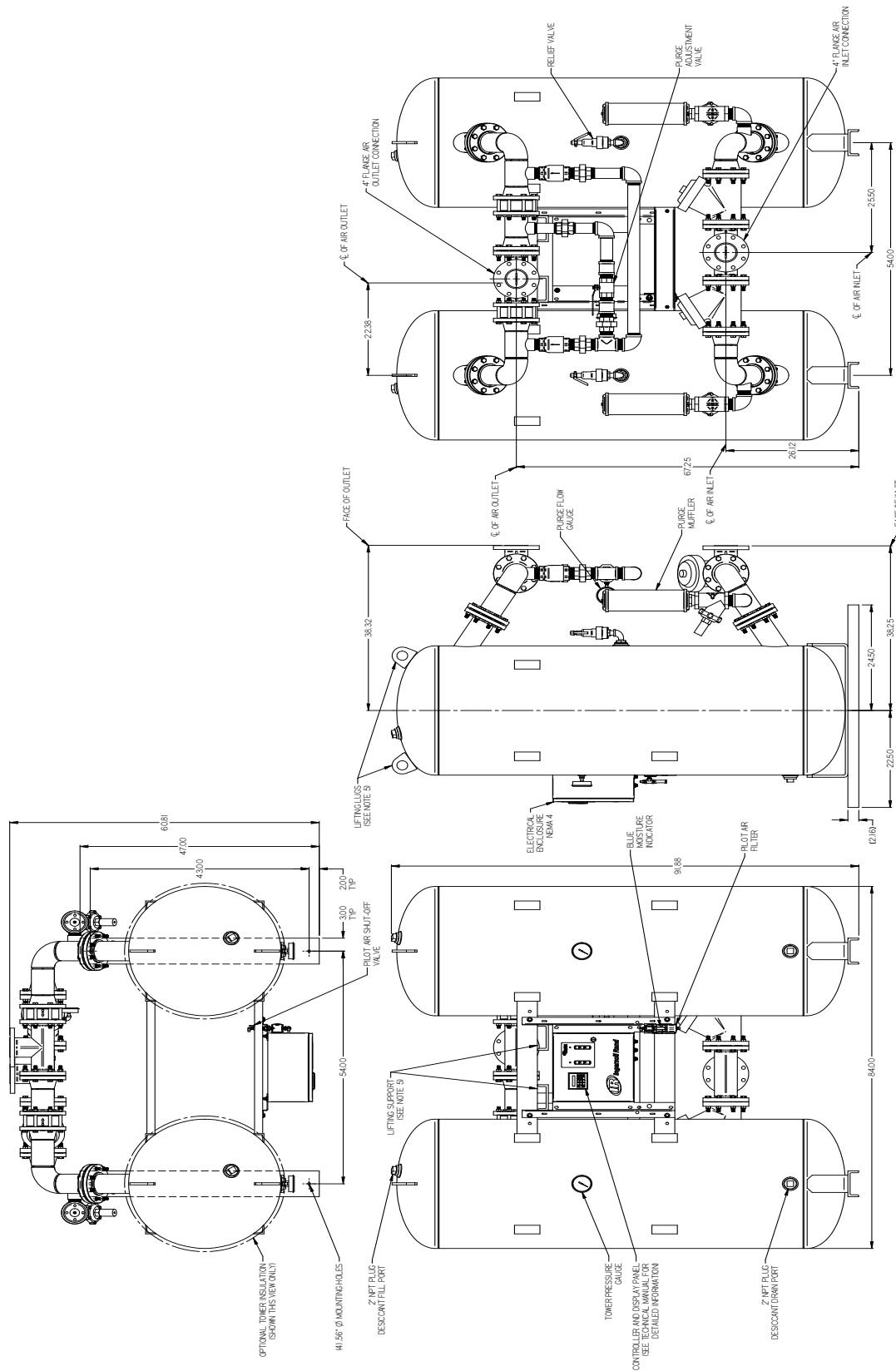

GENERAL ARRANGEMENT
HL2700
580007-G

- NOTES**
- 1) MAXIMUM WORKING PRESSURE - 150 PSI.
 - 2) SAFETY RELIEF VALVE SETTING - 165 PSI.
 - 3) ELECTRICAL CONNECTIONS SHALL BE MADE IN ACCORDANCE WITH THE NATIONAL ELECTRICAL CODE'S LATEST EDITION.
 - 4) ALL WORKS SHALL CONFORM WITH THE NATIONAL ELECTRICAL CODE'S LATEST EDITION.
 - 5) ORDER TO BE LIFTED BY LIFTING LUGS SUPPORT ONLY.
 - 6) DESIGNS REPERT FOR STANDARD MODEL. THIS DRAWING DOES NOT DEPICT OPTIONS.
 - 7) THE UNIT DIMENSIONS WILL VARY FOR PRODUCTS COMPAIRED WITH OPTIONS.
 - 8) THE LOCATION OF THE COMPRESSOR SHALL BE DETERMINED BY THE CUSTOMER. THE DRAWINGS CAN BE PROVIDED UPON REQUEST.
 - 9) DESIGNED DIMENSIONS ARE SUBJECT TO CHANGE WITHOUT NOTICE.
 - 10) LOCATION OF COMPRESSED AIR INLET & OUTLET CONNECTIONS MAY VARY BASED ON OPTIONS SELECTED.
 - 11) FILTER PACKAGES SHIPPED SEPARATELY. FILTER SPRINGS SUPPORT, IF REQUIRED, TO BE SUPPLIED BY CUSTOMER.

14.0 GENERAL ARRANGEMENT

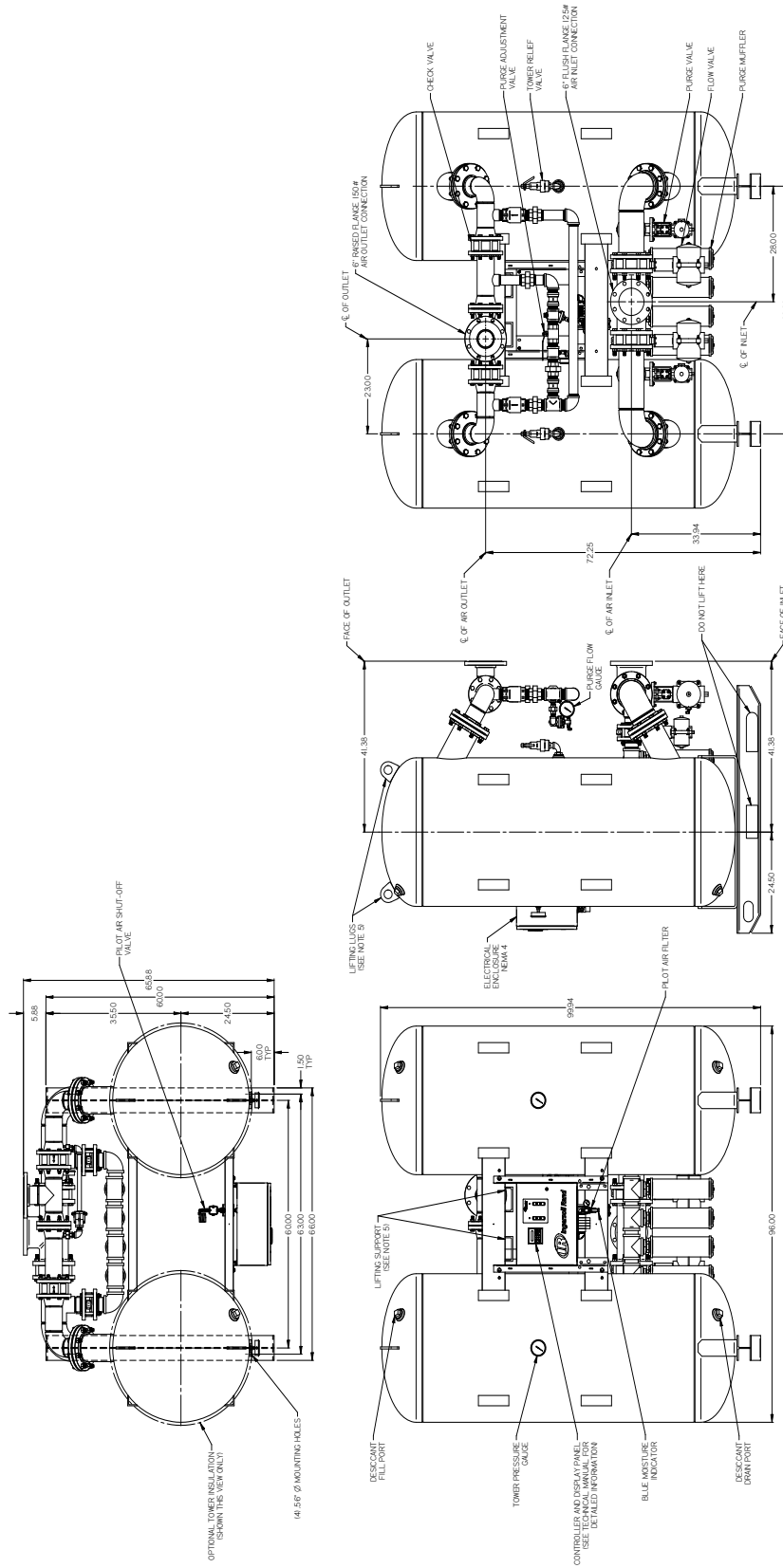

GENERAL ARRANGEMENT
HL3300-HL4000
580092-G

1. MAXIMUM WORKING PRESSURE - 160 PSI
 2. SAFETY RELIEF VALVE SETTING - 165 PSI
 3. ALL DIMENSIONS ARE IN INCHES UNLESS OTHERWISE SPECIFIED
 4. ALL WIRING IS IN ACCORDANCE WITH THE NATIONAL ELECTRICAL CODE'S LATEST EDITION
 5. ORDER TO BE LIFTED BY LIFTING LUGS/SLIP RINGS ONLY
 6. DIMENSIONS IN PARENTHESES ARE NOT SHOWN OPTIONS
 7. THE UNIT DIMENSIONS WILL VARY FOR PRODUCTS CONFIGURED WITH OPTIONS
 8. THIS DRAWING IS PROVIDED FOR REFERENCE PURPOSES ONLY. CERTIFIED DRAWINGS CAN BE PROVIDED UPON REQUEST.
 9. THE LOCATION OF COMPRESSED AIR INLET & OUTLET CONNECTIONS MAY VARY BASED ON OPTIONS SELECTED.
 10. FILTER PACKAGES SHIPPED SEPARATELY. FILTERING SUPPORT IF REQUIRED, TO BE SUPPLIED BY CUSTOMER.

14.0 GENERAL ARRANGEMENT

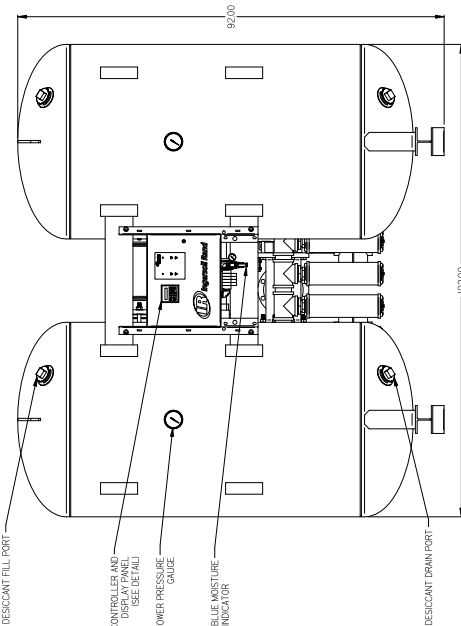
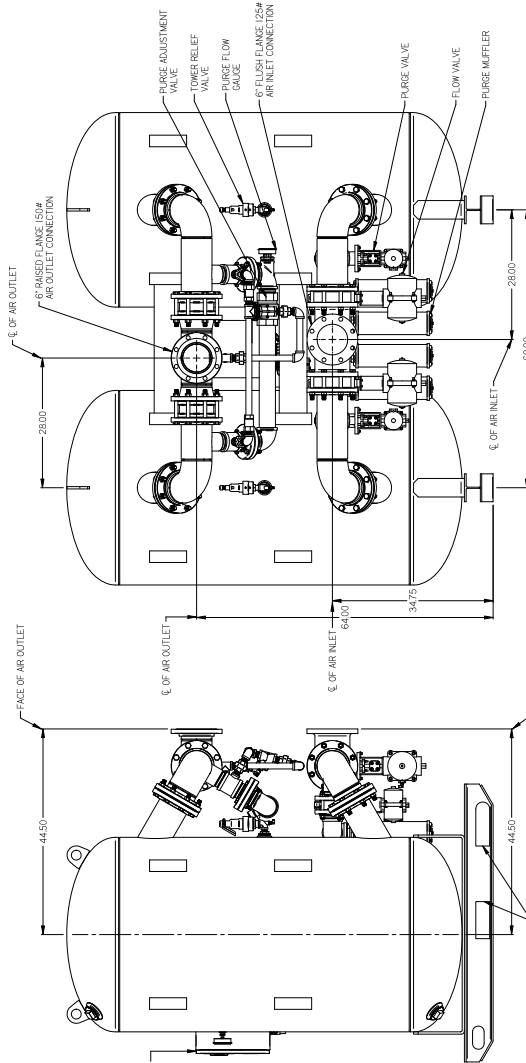
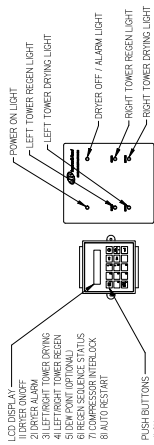
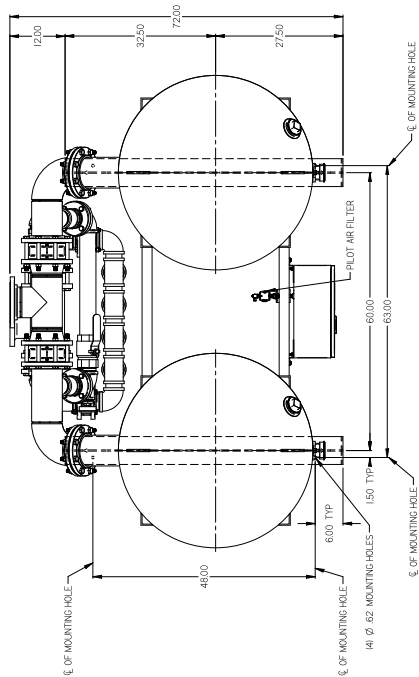

NOTES:
 1. MAXIMUM WORKING PRESSURE - 100 PSIG
 2. MAXIMUM WORKING TEMPERATURE - 100°F (38°C)
 3. PURGE FLOW GAUGE IS NOT STANDARD EQUIPMENT
 4. ALL WORK IS ACCORDING WITH THE
 5. ALL TO BE PROVIDED SHIPPED SEPARATELY.
 6. PURGE FLOW GAUGE IS REQUIRED TO BE
 SUPPLIED BY CUSTOMER.

GENERAL ARRANGEMENT
 HL5000
 580306-C

15.0 WIRING DIAGRAM

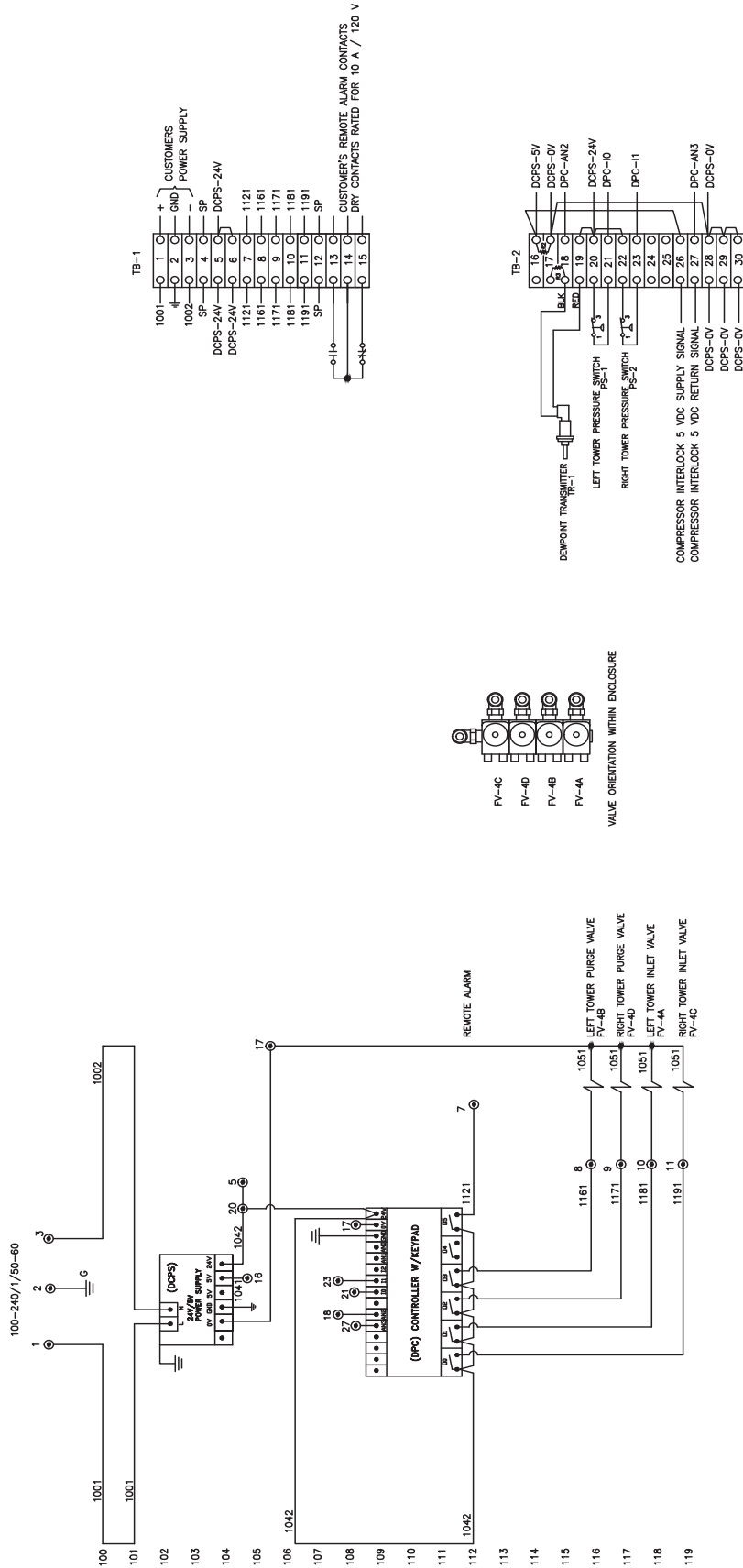

RESISTANCE VALUES:
 R2 = 200 OHM, 1/2 W, 5 %
 R3 = 250 OHM, 1/4 W, 0.1 %

ITEMS THAT APPEAR IN GRAY MAY NOT BE INCLUDED. THESE ITEMS ARE OPTIONAL OR ADDED AS REQUIRED PER DRYER ORDER.

WIRING DIAGRAM
 HL800-HL5000
 580078-D

16.0 FLOW DIAGRAM

- LEGEND**
- DRYING AIR FLOW
 - REGENERATING AIR FLOW
 - DRYER AIR PIPING
 - CONTROL AIR PIPING
 - - - OPTIONAL PIPING
- DR-1 INLET FILTER DRAIN
 - ERI-1 CONTROL AIR FILTER ELEMENT REPLACEMENT INDICATOR
 - ERI-2 INLET FILTER ELEMENT REPLACEMENT INDICATOR
 - ERI-3 OUTLET FILTER ELEMENT REPLACEMENT INDICATOR
 - EXH-1 TOWER PURGE MUFFLER
 - FLT-1 PILOT AIR FILTER
 - FLT-2 HIGH EFFICIENCY PREFILTER
 - FLT-3 DUST PARTICULATE AFTERFILTER
 - FO-1 PURGE ORIFICE
 - FV-1A LEFT TOWER INLET VALVE
 - FV-2A RIGHT TOWER INLET VALVE
 - FV-4A LEFT TOWER INLET SOLENOID CONTROL VALVE
 - FV-1B LEFT TOWER PURGE VALVE
 - FV-2B RIGHT TOWER PURGE VALVE
 - FV-4B LEFT TOWER PURGE SOLENOID CONTROL VALVE
 - FV-1C LEFT TOWER CHECK VALVE
 - FV-2C RIGHT TOWER CHECK VALVE
 - FV-4C RIGHT TOWER INLET SOLENOID CONTROL VALVE
 - FV-4D RIGHT TOWER PURGE SOLENOID CONTROL VALVE
 - FV-1P LEFT TOWER PURGE CHECK VALVE
 - FV-2P RIGHT TOWER PURGE CHECK VALVE
 - FX-1 UPPER FLOW DISTRIBUTION SCREEN
 - FX-2 LOWER FLOW DISTRIBUTION SCREEN
 - HCV-1 PURGE FLOW METERING VALVE
 - HCV-2 DRYER AIR SHUTOFF VALVE
 - HCV-3 MOISTURE INDICATOR
 - MI-4 ENERGY MANAGEMENT SYSTEM (EMS) TRANSMITTER (OPTIONAL)
 - MIC-1 LEFT TOWER PRESSURE GAUGE
 - PI-1 RIGHT TOWER PRESSURE GAUGE
 - PI-2 PURGE PRESSURE GAUGE
 - PI-3 LEFT TOWER PRESSURE SWITCH (OPTIONAL)
 - PS-1 RIGHT TOWER PRESSURE SWITCH (OPTIONAL)
 - PSV-1 LEFT TOWER SAFETY RELIEF VALVE
 - PSV-2 RIGHT TOWER SAFETY RELIEF VALVE

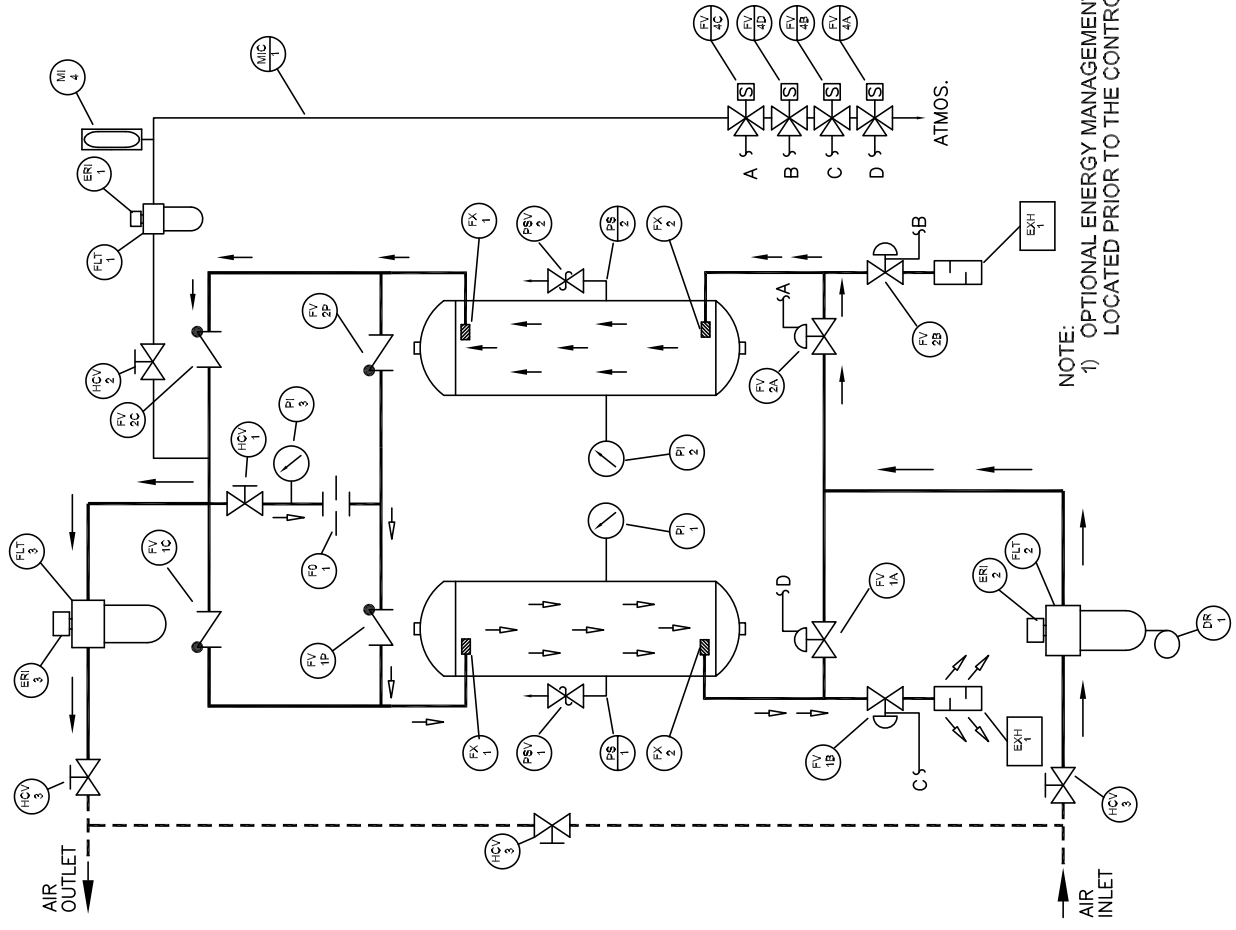

NOTE:
 1) OPTIONAL ENERGY MANAGEMENT SYSTEM TRANSMITTER (MIC-1) IS LOCATED PRIOR TO THE CONTROL AIR FILTER ON -80°F & -100°F DRYERS

FLOW DIAGRAM
 HL800-HL2700
 580022-E

16.0 FLOW DIAGRAM

LEGEND

- DRYING AIR FLOW
- REGENERATING AIR FLOW
- DRYER AIR PIPING
- CONTROL AIR PIPING
- - - OPTIONAL PIPING

- EXH-1 — PURGE MUFFLER (4 REQUIRED ON 3300 & UP)
- FLT-1 — PILOT AIR FILTER
- FO-1 — PURGE ORIFICE
- FV-1A — LEFT TOWER INLET VALVE
- FV-2A — RIGHT TOWER INLET VALVE
- FV-4A — LEFT TOWER INLET SOLENOID CONTROL VALVE
- FV-1B — LEFT TOWER PURGE VALVE
- FV-2B — RIGHT TOWER PURGE VALVE
- FV-1P — LEFT TOWER PURGE CHECK VALVE
- FV-2P — RIGHT TOWER PURGE CHECK VALVE
- FV-4B — LEFT TOWER PURGE SOLENOID CONTROL VALVE
- FV-1C — LEFT TOWER CHECK VALVE
- FV-2C — RIGHT TOWER CHECK VALVE
- FV-4C — RIGHT TOWER INLET SOLENOID CONTROL VALVE
- FV-4D — RIGHT TOWER PURGE SOLENOID CONTROL VALVE
- FV-5 — REPRESSURIZATION VALVE (OPTIONAL)
- FX-1 — UPPER FLOW DISTRIBUTION SHUTTLE VALVE (OPTIONAL)
- FX-2 — LOWER FLOW DISTRIBUTION SCREEN
- HCV-1 — PURGE FLOW METERING VALVE
- HCV-2 — CONTROL AIR LINE FILTER SHUTOFF VALVE
- MI-4 — MOISTURE INDICATOR
- MIC-1 — ENERGY MANAGEMENT SYSTEM (EMS) TRANSMITTER (OPTIONAL)
- PI-1 — LEFT TOWER PRESSURE GAUGE
- PI-2 — RIGHT TOWER PRESSURE GAUGE
- PI-3 — PURGE PRESSURE GAUGE
- PI-4 — REGULATOR PRESSURE GAUGE
- PR-1 — CONTROL AIR PRESSURE REGULATOR
- PS-1 — LEFT TOWER PRESSURE SWITCH (OPTIONAL)
- PS-2 — RIGHT TOWER PRESSURE SWITCH (OPTIONAL)
- PSV-1 — LEFT TOWER SAFETY RELIEF VALVE
- PSV-2 — RIGHT TOWER SAFETY RELIEF VALVE

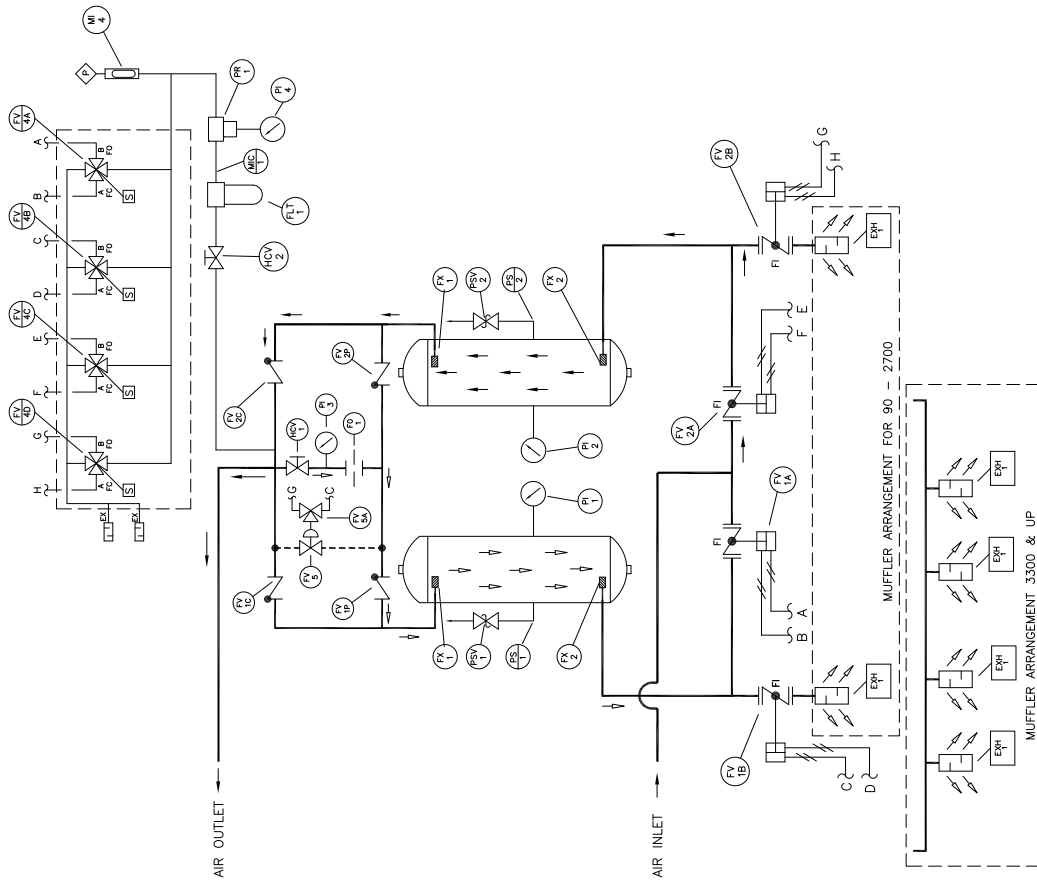

- NOTES:
- 1) OPTIONAL FILTER ASSEMBLIES NOT SHOWN
 - 2) OPTIONAL ENERGY MANAGEMENT SYSTEM TRANSMITTER (MIC-1) IS LOCATED PRIOR TO THE CONTROL AIR FILTER ON -80° F & -100° F DRYERS

FLOW DIAGRAM
 HL800-HL5000
 WITH FOUR-WAY VALVES AND OPTIONS
 580213-F

17.0 REPLACEMENT PARTS

DESCRIPTION	HL8001H00	HL10001H00	HL12001H00	HL15001H00	HL18001H00	QTY/ UNIT	SPARES		
	AA	AA	AA	AA	AL		1	2	3
BLUE MOISTURE INDICATOR	38054284	38054284	38054284	38054284	38054284	1			
DESICCANT, 4-8mm GRADE D	NOTE 1	NOTE 1	NOTE 1	NOTE 1	NOTE 1	NOTE 1			
DISPLAY BOARD, PANEL	38053682	38053682	38053682	38053682	38053682	1			
DRYER CONTROLLER T4 WITH DESICCANT PROGRAM (Dryer model and serial number must be provided with order to ensure proper configuration).	24331811	24331811	24331811	24331811	24331811	1			
ELEMENT, PILOT AIR FILTER	Refer to page 45 for Pilot Air Filter Element Section					1	1	1	2
ELEMENT, PRE-FILTER 920 SCFM	24242471	-	-	-	-	1	1	1	1
ELEMENT, PRE-FILTER 1080 SCFM	-	24242513	-	-	-	1	1	1	1
ELEMENT, PRE-FILTER 1350 SCFM	-	-	24242554	-	-	1	1	1	1
ELEMENT, PRE-FILTER 1600 SCFM	-	-	-	24242596	-	1	1	1	1
ELEMENT, PRE-FILTER 1800 SCFM	-	-	-	-	38446357	3	3	3	3
ELEMENT, POST-FILTER 920 SCFM	24242463	-	-	-	-	1	1	1	1
ELEMENT, POST-FILTER 1080 SCFM	-	24242505	-	-	-	1	1	1	1
ELEMENT, POST-FILTER 1350 SCFM	-	-	24242547	-	-	1	1	1	1
ELEMENT, POST-FILTER 1600 SCFM	-	-	-	24242588	-	1	1	1	1
ELEMENT, POST-FILTER 1800 SCFM	-	-	-	-	23553357	3	3	3	3
GAUGE, PURGE/TOWER PRESSURE 3 1/2"	38052973	38052973	38052973	38052973	38052973	3			
MUFFLER, PURGE, 1 1/2"	38054540	38054540	38054540	-	-	2	2	2	2
MUFFLER, PURGE, 2"	-	-	-	38054045	38054045	2	2	2	2
OVERLAY, CONTROLLER	23540198	23540198	23540198	23540198	23540198	1			
POWER SUPPLY, 5V/24VDC	23548621	23548621	23548621	23548621	23548621	1	1	1	1
RESISTOR, 5V LOAD, 200 OHM	38054151	38054151	38054151	38054151	38054151	1			
RETAINER, SCREEN ASSEMBLY 3"	38054565	38054565	38054565	-	-	4			
RETAINER, SCREEN ASSEMBLY 4"	-	-	-	38054292	38054326	4			
VALVE, DIAPHRAGM, 1 1/2" P.O.N.C.	38052932	38052932	38052932	-	-	2			
VALVE, DIAPHRAGM, 2" P.O.N.C.	-	-	-	38053088	38053088	2			
VALVE, DIAPHRAGM, 3" P.O.N.O.	38052981	38052981	38052981	-	-	2			
VALVE, DIAPHRAGM, 4" P.O.N.O.	-	-	-	38052924	38052924	2			
VALVE, BALL, CONTROL AIR, 1/4"	38054086	38054086	38054086	38054086	38054086	1			
VALVE, BALL, PURGE ADJUST, 1 1/2"	38054052	38054052	38054052	38054052	38054052	1			
VALVE, CHECK, PURGE, 1 1/2"	23354582	23354582	23354582	23354582	23354582	2			
VALVE, CHECK, FLOW, 3"	38053484	38053484	38053484	38053484	38053484	2			
VALVE, SAFETY/RELIEF 1/2"	38054060	38054060	38054060	38054060	-	2			
VALVE, SAFETY/RELIEF 3/4"	-	-	-	-	38054375	2			
VALVE, SOLENOID 24VDC MINI	38053054	38053054	38053054	38053054	38053054	1			

17.0 REPLACEMENT PARTS

NOTE 1: Refer to the Desiccant Fill Chart in the Maintenance section.

Spare. Quantities under this heading reflect the number of each item which we recommend be kept on hand for maintenance or repair.

The appropriate quantity for your application will depend on how critical interruptions in service are to your operation.

Class	Quantity	Suggested for
1	Minimum	Domestic service where interruptions in service are acceptable.
2	Average	Domestic service where some interruptions in service are acceptable.
3	Maximum	Export service or for domestic service where interruptions in service are unacceptable.

17.0 REPLACEMENT PARTS

DESCRIPTION	HL21001H00	HL27001H00	HL33001H00	HL40001H00	HL50001H00	QTY/ UNIT	SPARES		
	AL	AL	AL	AL	AL		1	2	3
BLUE MOISTURE INDICATOR	38054284	38054284	38054284	38054284	38054284	1			
DESICCANT, 4-8mm GRADE D	NOTE 1	NOTE 1	NOTE 1	NOTE 1	NOTE 1	NOTE 1			
DISPLAY BOARD, PANEL	38053682	38053682	38053682	38053682	38053682	1			
DRYER CONTROLLER T4 WITH DESICCANT PROGRAM (Dryer model and serial number must be provided with order to ensure proper configuration).	24331811	24331811	24331811	24331811	24331811	1			
ELEMENT, PILOT AIR FILTER	Refer to page 45 for Pilot Air Filter Element Section					1	1	1	2
ELEMENT, PRE-FILTER 2400 SCFM	38446357	-	-	-	-	4	4	4	4
ELEMENT, PRE-FILTER 3000 SCFM	-	38446357	-	-	-	5	5	5	5
ELEMENT, PRE-FILTER 3600 SCFM	-	-	38446357	-	-	6	6	6	6
ELEMENT, PRE-FILTER 4200 SCFM	-	-	-	38446357	-	7	7	7	7
ELEMENT, PRE-FILTER 6000 SCFM	-	-	-	-	38446357	10	10	10	10
ELEMENT, POST-FILTER 2400 SCFM	23553357	-	-	-	-	4	4	4	4
ELEMENT, POST-FILTER 3000 SCFM	-	23553357	-	-	-	5	5	5	5
ELEMENT, POST-FILTER 3600 SCFM	-	-	23553357	-	-	6	6	6	6
ELEMENT, POST-FILTER 4200 SCFM	-	-	-	23553357	-	7	7	7	7
ELEMENT, POST-FILTER 6000 SCFM	-	-	-	-	23553357	10	10	10	10
GAUGE, PURGE/TOWER PRESSURE 3 1/2"	38052973	38052973	38052973	38052973	38052973	3			
MUFFLER, PURGE, 2"	38054045	38054045	38054045	38054045	38054045	2	2	2	2
OVERLAY, CONTROLLER	23540198	23540198	23540198	23540198	23540198	1			
POWER SUPPLY, 5V/24VDC	23548621	23548621	23548621	23548621	23548621	1	1	1	1
RESISTOR, 5V LOAD, 200 OHM	38054151	38054151	38054151	38054151	38054151	1			
RETAINER, SCREEN ASSEMBLY 4"	38054326	38054326	-	-	-	4			
RETAINER, SCREEN ASSEMBLY 6"	-	-	38054300	38054300	38054334	4			
VALVE, DIAPHRAGM, 2" P.O.N.C.	38053088	38053088	-	-	-	2			
VALVE, DIAPHRAGM, 3/ 4" P.O.N.O.	-	-	23181266	23181266	-	2			
VALVE, DIAPHRAGM, 1" P.O.N.O.	-	-	-	-	38453833	2			
VALVE, DIAPHRAGM, 4" P.O.N.O.	38052924	38052924	-	-	-	2			
VALVE, BUTTERFLY, 3"	-	-	38053393	38053393	38053393	2			
VALVE, BUTTERFLY, 6"	-	-	38053419	38053419	38053419	2			
VALVE, BALL, CONTROL AIR, 1/4"	38054086	38054086	38054086	38054086	38054086	1			
VALVE, BALL, PURGE ADJUST, 1 1/2"	38054052	-	-	-	-	1			
VALVE, BALL, PURGE ADJUST, 2"	-	38054532	38054532	38054532	38054532	1			
VALVE, CHECK, PURGE, 1 1/2"	23354582	-	-	-	-	2			
VALVE, CHECK, PURGE, 2"	23321292	23321292	23321292	23321292	-	2			
VALVE, CHECK, PURGE, 3"	-	-	-	-	23557945	2			
VALVE, CHECK, FLOW, 3"	38053484	-	-	-	-	2			
VALVE, CHECK, FLOW, 4"	-	38053567	38053567	38053567	-	2			

17.0 REPLACEMENT PARTS

VALVE, CHECK, FLOW, 6"	-	-	-	-	38053575	2			
VALVE, SAFETY/RELIEF 3/4"	38054375	38054375	38054375	38054375	38054375	2			
VALVE, SOLENOID 24VDC MINI	38053054	38053054	-	-	-	4			
VALVE, SOLENOID 24VDC MINI	-	-	38053625	38053625	38053625	4			

NOTE 1: Refer to the Desiccant Fill Chart in the Maintenance section.

Spare. Quantities under this heading reflect the number of each item which we recommend be kept on hand for maintenance or repair.

The appropriate quantity for your application will depend on how critical interruptions in service are to your operation.

Class	Quantity	Suggested for
1	Minimum	Domestic service where interruptions in service are acceptable.
2	Average	Domestic service where some interruptions in service are acceptable.
3	Maximum	Export service or for domestic service where interruptions in service are unacceptable.

17.0 REPLACEMENT PARTS

DIAPHRAGM VALVE REBUILD KITS

VALVE DESCRIPTION	VALVE CCN *	SEAL KIT CCN	HARDWARE KIT CCN
VALVE, DIAPHRAGM, 1-1/2" P.O.N.C.	38052932	38052668	38052825
VALVE, DIAPHRAGM, 2" P.O.N.C.	38053088	38052866	38052965
VALVE, DIAPHRAGM, 3/4" P.O.N.O.	23181266	38052114	38052619
VALVE, DIAPHRAGM, 1" P.O.N.O.	38453833	38052114	38052619
VALVE, DIAPHRAGM, 3" P.O.N.O.	38052981	38053005	38053013
VALVE, DIAPHRAGM, 4" P.O.N.O.	38052924	38053021	38053039

NOTE: Refer to the list of individual parts at the beginning of the REPLACEMENT PARTS section to determine which Valve listed in the above table is applicable to your dryer. PART #'s for the relevant Seal Kits and Hardware Kits will be found in the adjacent columns.

EMS REPLACEMENT PARTS	
DESCRIPTION	CCN #
TRANSMITTER, DEWPOINT	23167778
CABLE, TRANSMITTER	38053112
BLOCK, SAMPLE	23167760

BUTTERFLY VALVE PARTS AND REBUILD KITS

VALVE DESCRIPTION	VALVE W/ ACT	VALVE ONLY	VALVE REPAIR KIT	ACTUATOR	ACTUATOR KIT
VALVE, BUTTERFLY 3"W/ ACTUATOR	38053393	23126865	23126923	23126980	23127053
VALVE, BUTTERFLY 6"W/ ACTUATOR	38053419	23126881	23126964	23127004	23127038

PILOT AIR FILTER REPLACEMENT ELEMENT

To determine the correct replacement element for the Pilot Air Filter, visually identify the filter that is mounted on the right side of the Electrical Enclosure and compare it to the options shown below. Select the replacement element that matches the Pilot Air Filter and use the corresponding Part Number when ordering

	
Use Replacement Element Part Number: 8556513	Use Replacement Element Part Number: 104424

18.0 ENGINEERING SPECIFICATIONS

MODEL	Inlet Flow -40 Dew- point SCFM	Inlet Flow -100 Dewpoint SCFM	Purge Flow (m ³ /h)	Width in. (cm)	Depth in. w/o Bypass (cm)	Depth in. w/ Bypass (cm)	Height in (cm)	Air In & Out Conne- ction	Shipping Weight lbs (kg)	Desiccant Weight per Dryer (kg)
HL800	800	640	130	64 (162.6)	51.25 (130.2)	64.38 (163.5)	87.62 (222.6)	3	2017 (915)	900 (408)
HL1000	1000	800	162	64 (162.6)	51.25 (130.2)	64.38 (163.5)	87.62 (222.6)	3	2237 (1015)	1100 (499)
HL1200	1200	960	195	64 (162.6)	51.25 (130.2)	64.38 (163.5)	87.62 (222.6)	3	2424 (1100)	1270 (576)
HL1500	1500	1200	243	78 (198.1)	54.76 (139.1)	N/A	80 (203.2)	4	2974 (1349)	1600 (726)
HL1800	1800	1440	292	84 (213.4)	60.62 (154.0)	N/A	91.88 (233.4)	4	3905 (1771)	2000 (907)
HL2100	2100	1680	340	84 (213.4)	60.62 (154.0)	N/A	91.88 (233.4)	4	4279 (1941)	2340 (1062)
HL2700	2700	2160	438	84 (213.4)	60.76 (154.3)	N/A	91.88 (233.4)	4	4926 (2234)	2928 (1328)
HL3300	3300	2640	535	96 (244)	66 (167.6)	N/A	100 (254)	6	2950 (1338)	3800 (1723) *
HL4000	4000	3200	649	96 (244)	66 (167.6)	N/A	100 (254)	6	3000 (1361)	4226 (1917) *
HL5000	5000	4000	811	102 (259)	72 (183)	N/A	92 (233.7)	6	3950 (1792)	5138 (2330) *

* Dryer weight shown does not include desiccant. Desiccant shipped separately.

Note: All above dryers rated at 150 psig, 120 °F max inlet temperature.

Capacity and purge flow is basis standard inlet conditions (100 psig / 100 °F) and will vary at different inlet conditions.

NOTICE

Specification information above accurate at time of publication. Refer to equipment serial label for actual specifications for units.

