

13-17-621
Version: 01
September 28th, 2020

Gardner Denver

Governor™ Controller

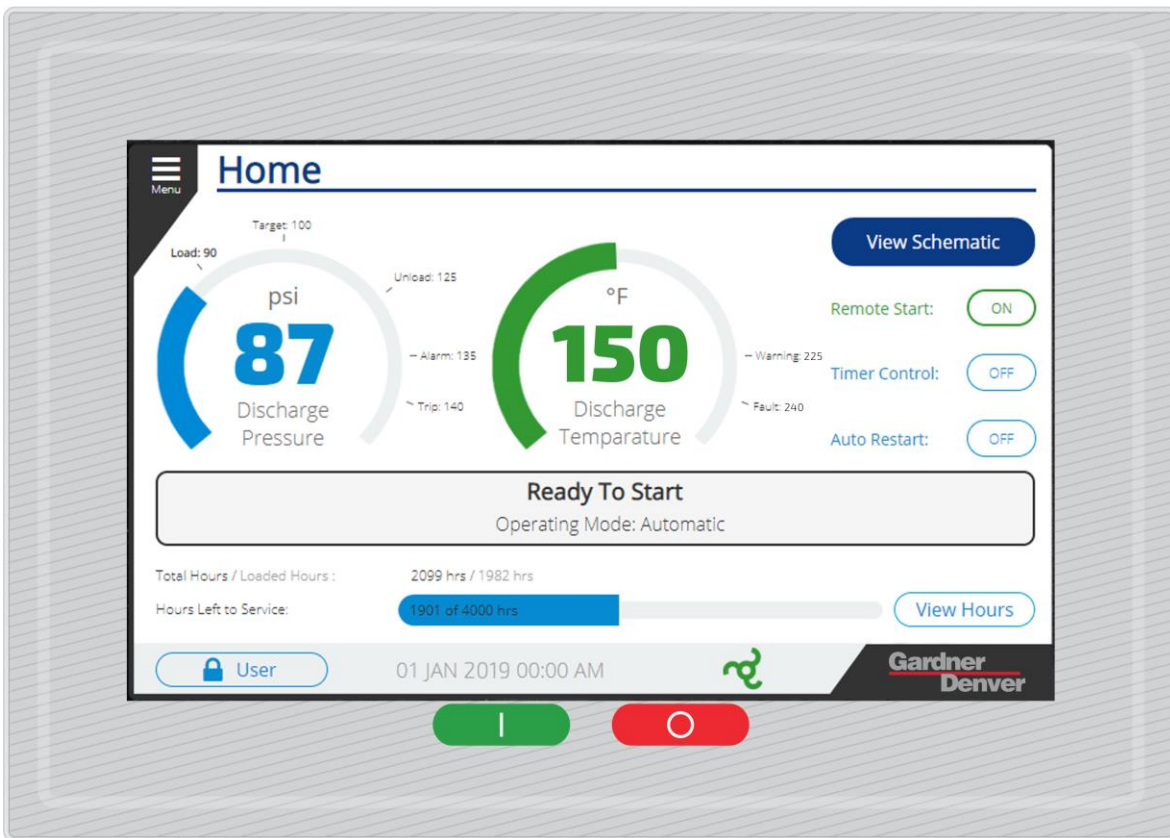

USER'S MANUAL

Rotary Screw Compressor Application

WARNING – PROHIBITION – MANDATORY LABEL INFORMATION

Gardner Denver compressors are the result of advanced engineering and skilled manufacturing. To be assured of receiving maximum service from this machine, the owner must exercise care in its operation and maintenance. This book is written to give the operator and maintenance department essential information for day-to-day operation, maintenance and adjustment. Careful adherence to these instructions will result in economical operation and minimum downtime.

Boxed text formats are used, within this manual, to alert users of the following conditions:

Safety Labels are used, within this manual and affixed to the appropriate areas of the compressor package, to alert users of the following conditions:



Indicates a hazard with a high level of risk, which if not avoided, WILL result in death or serious injury.



Equipment Starts Automatically



Health Hazard – Explosive Release of Pressure



Cutting of Finger or Hand Hazard – Rotating Impeller Blade



High Voltage – Hazard of Shock, Burn, or Death Present until Electrical Power is Removed



Cutting of Finger or Hand Hazard – Rotating Fan Blade



Entanglement of Fingers or Hand/Rotating Shaft

WARNING

Indicates a hazard with a medium level of risk which, if not avoided, COULD result in death or serious injury.



Asphyxiation Hazard – Poisonous Fumes or Toxic Gases in Compressed Air

CAUTION

Indicates a hazard with a low level of risk which, if not avoided, MAY result in a minor or moderate injury.



Burn Hazard – Hot surface

PROHIBITION/MANDATORY ACTION REQUIREMENTS



Do not Operate Compressor with Guard Removed



Lockout Electrical Equipment in De-Energized State



Do Not Lift Equipment with Hook – No Lift Point



Loud Noise Hazard – Wear Ear Protection



Handle Package at Forklift Points Only



Read the Operator's Manual Before Proceeding with Task

SAFETY PRECAUTIONS

Safety is everybody's business and is based on your use of good common sense. All situations or circumstances cannot always be predicted and covered by established rules. Therefore, use your past experience, watch out for safety hazards and be cautious. Some general safety precautions are given below:



Failure to observe these notices will result in injury to or death of personnel.

- **Keep fingers and clothing away** from rotating fan, drive coupling/belting, etc.
- **Disconnect the compressor unit** from its power source, lockout and tagout before working on the unit – this machine is automatically controlled and may start at any time.
- **Do not loosen or remove** the enclosure or belt covers, or break any connections, etc., in the compressor air system until the unit is shut down and the air pressure has been relieved.
- **Electrical shock** can and may be fatal.
- **Perform all wiring** in accordance with the National Electrical Code (NFPA-70) and any applicable local electrical codes. Wiring and electrical service must be performed only by qualified electricians.
- **Open main disconnect switch**, lockout and tagout and check for voltage before working on the control.



Failure to observe these notices could result in damage to equipment.

- **Stop the unit** if any repairs or adjustments on or around the compressor are required.
- **Do not use the air discharge** from this unit for breathing – not suitable for human consumption.
- **An Excess Flow Valve** should be on all compressed air supply hoses exceeding 1/2 inch inside diameter (OSHA Regulation, Section 1926.302).
- **Do not exceed** the rated maximum pressure values shown on the nameplate.
- **Do not operate unit** if safety devices are not operating properly. Check periodically. Never bypass safety devices.

TABLE OF CONTENTS

SECTION 1 REVISION HISTORY	8
SECTION 2 GENERAL	9
2.1 Components and Layout	9
2.1.1 Display	9
2.1.2 IO Module	10
2.1.3 Cellular Module	11
2.2 Features and Method of Control	11
2.3 Hardware Specs	11
2.3.1 Display Module	11
2.3.1.1 Technical Data:	13
2.3.1.2 Diagnostics LEDs:	14
2.3.1.3 Reset Button / Operating Modes:	15
2.3.1.4 Connection Elements:	15
2.3.2 IO Module:	17
2.3.2.1 Technical Data:	17
2.3.2.2 Wiring:	19
2.3.2.3 Status LED:	20
2.3.2.4 Connection Interface:	20
2.3.2.5 Terminal Block Connections:	21
SECTION 3 QUICK START	29
3.1 Common User Interface Elements	29
3.1.1 Common Navigation and Status Elements	29
3.1.2 Buttons and Switches	30
3.1.3 Scroll Elements	31
3.1.3 Settings and Input Elements	32
3.1.3.1 Dropdown Boxes	32
3.1.3.2 Value Settings	33
3.2 Home Screen	34
3.2.1 Screen Saver	36
3.3 Schematic Screen	37
3.4 Navigation Menu	40
3.5 Logging In	41
3.6 Setting Up	42
3.6.1 Controller Configuration	42
3.6.2 Control Settings	44
3.7 Clearing Alarms	45
3.8 Jogging the Motors	46
3.9 Operating the Compressor	47
3.9.1 Starting	47
3.9.2 Running	47
3.9.3 Stopping	48
3.9.4 Emergency Stop	49
SECTION 4 SETTINGS	50
4.1 Service	50
4.1.1 Dashboard	51
4.1.1.1 Set Intervals:	53
4.1.1.2 Presetting a Timer Value	54
4.1.2 Distributor Info	55
4.2 Control	56
4.2.1 Operating Mode	57
4.2.2 p1 Pressure Band	58
4.2.3 p2 Pressure Band	60
4.2.4 IV Control Mode	61
4.2.5 Remote Halt Mode	61
4.2.6 Timer Start Enable	62
4.2.7 Restart Delay Time	63
4.2.8 p2 Timer Enable	63
4.2.9 Max Power Loss Time	63
4.2.10 Unlimited Power Loss Time	64

4.2.11 Auto Restart Enable.....	64
4.2.12 Dryer Pre-Run Time.....	64
4.3 Configuration	65
4.3.1 Locale	66
4.3.2 Date & Time	68
4.3.3 Communication	69
4.3.4 Security	71
4.3.5 Advanced	72
4.4 Sequencing.....	74
4.4.1 Sequencing Types:	74
4.4.2 AirSmart Protocol:.....	75
4.4.3 Delcos Protocol:.....	76
4.5 Timer Control.....	76
4.5.1 Timer Start Stop:.....	77
4.5.2 Press Band p2 Timer:	79
4.6 Programmable I/O	82
4.6.1 Digital Inputs:	83
4.6.2 Digital Outputs:	86
4.6.3 Temperature Inputs:	88
4.6.4 Analog Inputs:	89
4.6.5 Analog Outputs:	90
4.7 Advanced.....	91
4.7.1 Setup:.....	91
4.7.1.1 Model:	92
4.7.1.2 Serial Number:	95
4.7.1.3 Design Pressure:	95
4.7.1.4 Max Volume Flow:	95
4.7.1.5 Oil Type:.....	96
4.7.1.6 System Voltage:.....	97
4.7.1.7 Motor SFA:.....	97
4.7.1.8 Elevation:	98
4.7.1.9 Total Hours:	99
4.7.1.10 Loaded Hours:	99
4.7.1.11 Brand:	100
4.7.2 Operating Limits:.....	100
4.7.2.1 Max Start Pressure:	101
4.7.2.2 Heavy Startup:	101
4.7.2.3 Minimum Start Temperature:	101
4.7.2.4 Discharge Temperature Warning:.....	101
4.7.2.5 Discharge Temperature Fault:	102
4.7.2.6 Delivery Pressure Warning:	103
4.7.2.7 Delivery Pressure Fault:	103
4.7.2.8 Additional Operating Limits.....	104
4.7.3 Control - Default:.....	104
4.7.3.1 Automatic Stop Time:	105
4.7.3.2 Rotation Direction Check:	105
4.7.3.3 Min Stop Time:.....	106
4.7.3.4 Minimum Run Time:.....	106
4.7.3.5 Acceleration Time:	107
4.7.3.6 Star Delta Time:	108
4.7.4 Control – Variable Speed:.....	108
4.7.4.1 Ext Speed Limit (min):	109
4.7.4.2 Ext Speed Limit (max):	109
4.7.4.3 Speed Control Source:	110
4.7.4.4 Capacity Limit:	111
4.7.4.5 Cold Start Time:.....	111
4.7.4.6 Cold Start Limit:	112
4.7.4.7 Manual Speed:.....	112
4.7.5 Cooling - Default:	113
4.7.5.1 Cooling Type:.....	113

4.7.5.2 Fan Control:	114
4.7.5.3 Fan Shutoff Delay:	114
4.7.6 PID Tuning:	115
4.7.7 Backup / Restore:	115
SECTION 5 ALARMS	117
5.1 Active Alarm	118
5.1.1 Contact Info:.....	161
5.1.2 Info:	161
5.2 Alarm History	162
SECTION 6 DIAGNOSTICS	164
6.1 Sequencing.....	164
6.2 Jog Motors	166
6.2.1 Jog Duration:.....	166
6.2.2 Selected Motor:.....	167
6.2.3 Jog Delay:	167
6.3 IO	168
6.4 Controller	171
6.4.1 General:	171
6.4.2 Logs:	172
6.4.3 System:	176
6.4.4 Update Software	181
6.4.5 Audit:	181
6.4.6 Logger:	182
6.4.7 Advanced:	183
6.5 iConn	185
6.6 Communication.....	185
6.7 Remote Control	186
6.8 VFD Diagnostics.....	187
SECTION 7 TRENDS	189
SECTION 8 WEB INTERFACE.....	192

SECTION 1

REVISION HISTORY

Version	Date	Notes
00	February 23 rd , 2019	First release
01	September 28th, 2020	Added Sections and details to manual

SECTION 2

GENERAL

The Gardner Denver Governor™ controller is an advanced electronic control system designed to provide efficient and user friendly operation of your Gardner Denver compressor. This manual describes the controller specifications and operation on Gardner Denver rotary screw compressors.

2.1 Components and Layout

The Governor™ control system is made up of several different components, described briefly in this section.

2.1.1 Display

The display is the primary component that the user interacts with. On the front of the display, there is a color touchscreen interface. The **Start** and **Stop** touch buttons are located directly below the screen. The display houses the processor and memory for the system and interfaces with the other components through communications ports on the back side.

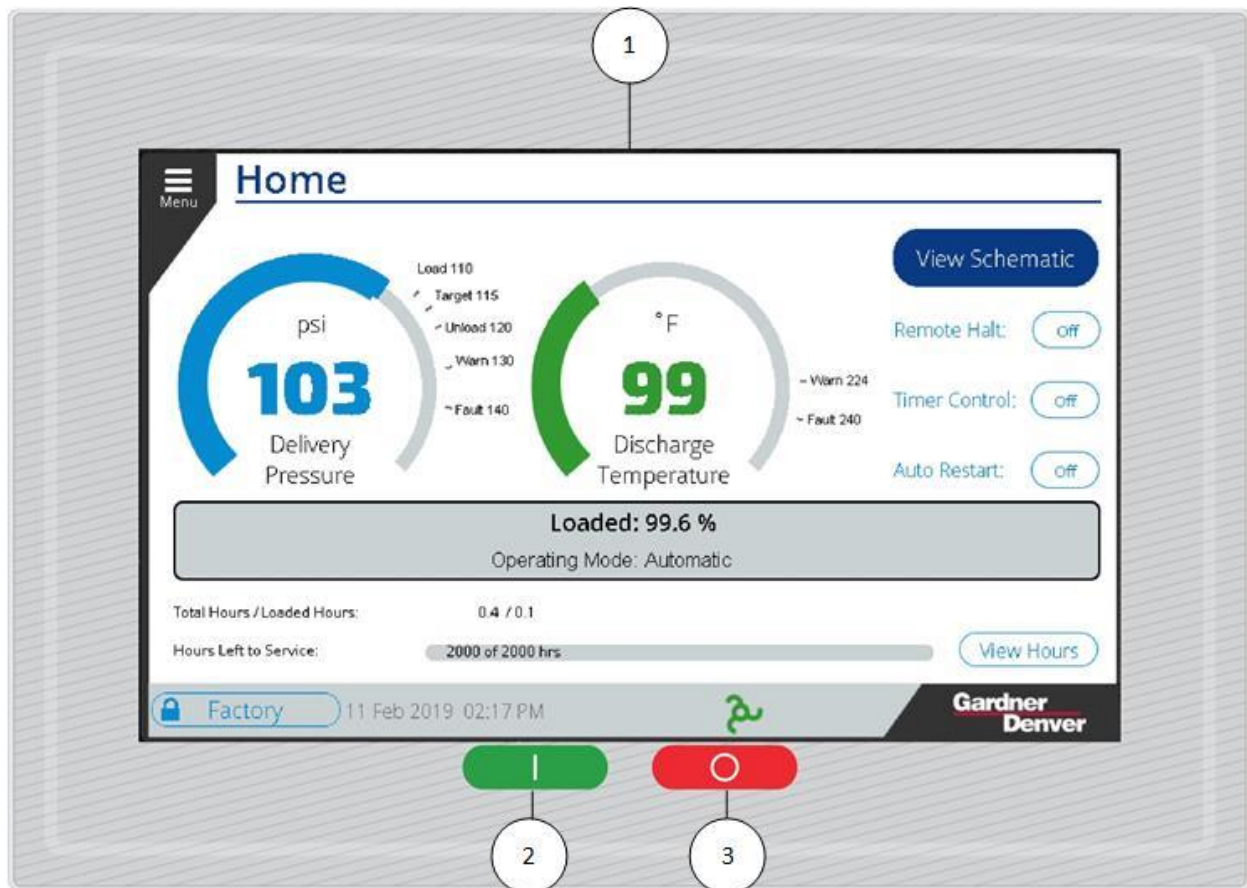

- 1: LCD Display / Touchscreen
- 2. Start button (touch)
- 3. Stop button (touch)

Figure 1: Home Screen Display

The display is shown above in Figure 1 with the Home screen visible. Note that the **Start** and **Stop** buttons as shown in the image are active areas of the touchscreen rather than physical push-buttons.

2.1.2 IO Module

The IO module is mounted inside the compressor control cabinet and connects to the display via RS485 communications and houses all of the terminations for the analog and digital input and output signals. These values are monitored and controlled by the display to operate the compressor. The IO module also contains RS485 communications ports for customer connection and sequencing with multiple machines.

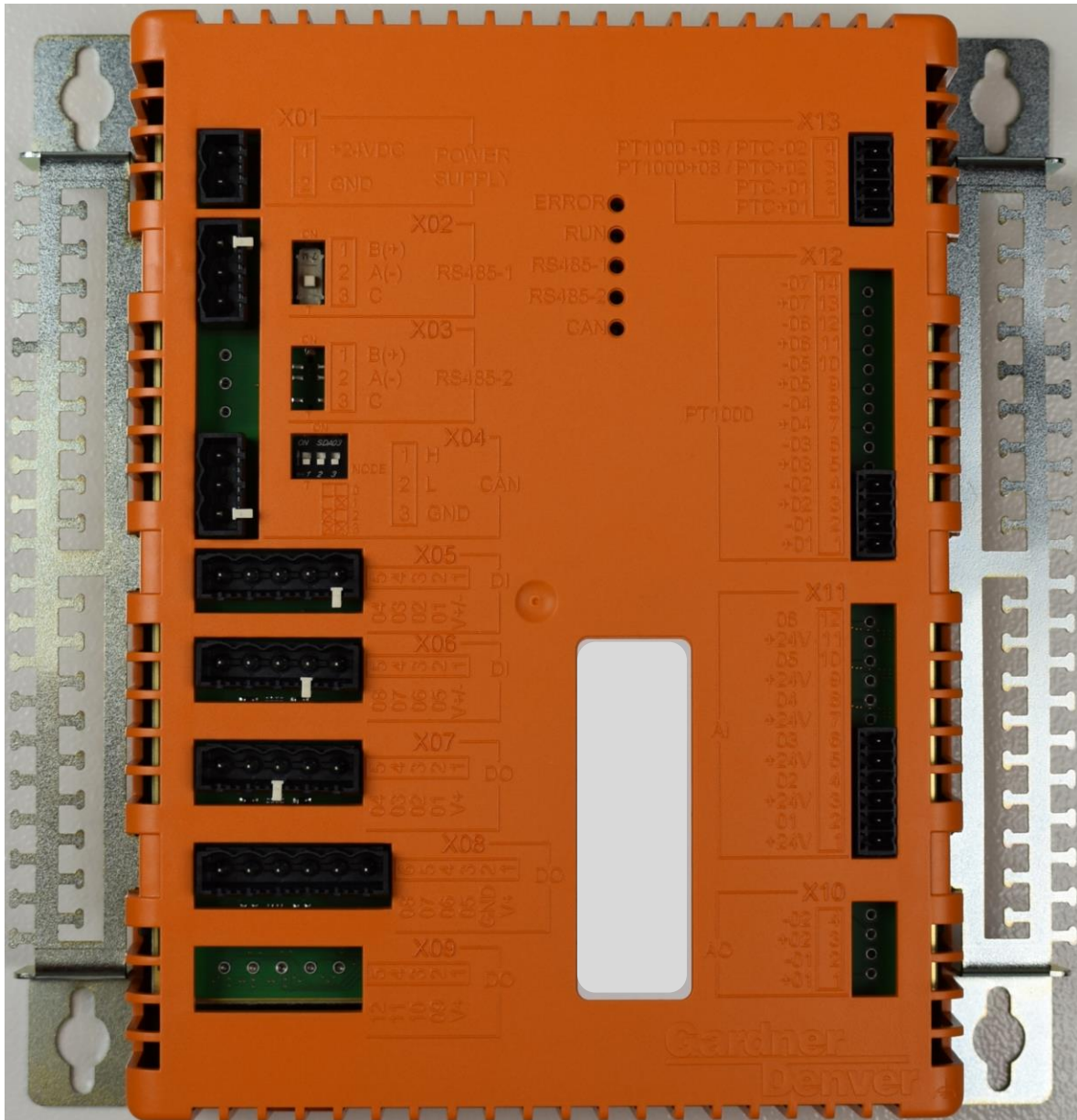

Figure 2: IO Module

The IO module is shown in Figure 2 above. Note that depending on the type of compressor you have, your IO module may have more or less inputs and outputs present on it, indicated by the amount and size of connectors on the board.

2.1.3 Cellular Module

The Governor™ controller features a cellular module that is connected to the display by USB. This connects into the iConn by Gardner Denver™ platform to provide machine health monitoring and analysis.



Figure 3: Cellular Module

The cellular module is shown in Figure 3 above. It is mounted in the control cabinet on DIN rail and connected to an antenna mounted on the top of the compressor package.

2.2 Features and Method of Control

The Governor™ controller is responsible for safe operation of the compressor package and is optimized for the customer based on their machine specifications. The Governor™ controller utilizes Gardner Denver's heritage of compressor package design and operation to intelligently determine when the machine is operating normally and when it needs attention. System inputs, such as pressure and temperature, are monitored individually and collectively to check for a variety of different system conditions.

When running the machine, the controller ensures that the customer's pressure requirements are maintained. After configuring and enabling the controller, all operation is automatic. The controller can be set up to start / stop on a schedule and use two different pressure bands to more efficiently meet system demand. Programmable inputs and outputs are available to interface to an array of external equipment. Modbus and remote interfaces are provided to monitor the machine.

2.3 Hardware Specs

2.3.1 Display Module

The display is a customized module, designed and developed for Gardner Denver. Figure 4: Oblique View & Figure 5: Rear View below shows the Oblique and Rear View of Display Module.



Figure 4: Oblique View



Figure 5: Rear View

2.3.1.1 Technical Data:

Table 1 below details the technical data of the display module.

Table 1: Display Module

Technical Data	
General Information	
Cooling	Passive
Reset button	Yes
Status Indicators	Supply voltage OK, operating state, module status, Ethernet, CAN Rx/Tx, RS485 Rx/Tx
Certification	UL
Interface	
Interface IF1	
Type	USB 2.0
Variant	Type A
Current Carrying Capacity	0.49 A
Interface IF2	
Type	USB 2.0
Variant	Type A
Current Carrying Capacity	0.49 A
Interface IF3	
Type	Ethernet
Variant	1XRJ45 Shielded
Line Length	Max. 100 m between 2 nodes (segment length)
Max. Transfer Rate	10/100 Mbit/s
Interface IF4	
Type	CAN bus
Variant	3 pins of the 6-pin multipoint connector
Bus terminating resistor	120 Ω , can be switched using software
Max. distance	1000 m
Interface IF5	
Type	RS485
Variant	3 pins of the 6-pin multipoint connector
Max. Distance	1200 m
Transfer rate	Max 115.2 kbit/s
Display	
Type	TFT color
Diagonal	7.0"
Colors	16.7 million (RGB, 8 bits per channel)
Resolution	WVGA, 800 x 480 pixels
Contrast	Typ. 600:1
Viewing Angles	
Horizontal	Direction L / Direction R = Typ. 70°
Vertical	Direction U / Direction D = Typ. 60°
Backlight	
Type	LED
Brightness	Typ. 500 cd/m ²
Touch screen	
Type	AMT
Technology	Analog resistive
Electrical Characteristic	
Nominal voltage	24 VDC -15% / +20%
Power consumption	Typ. 6 W / Max. 12.5 W
Reverse polarity protection	Yes
Electrical isolation	Ethernet (IF3) to other interfaces and to device

Operating conditions	
Installation elevation above sea level	
0 to 2000 m	No limitation
>2000 m	Reduction of ambient temperature by 0.5°C per 100 m
Ambient Conditions	
Temperature	
Operation	-20 to 60°C
Storage	-25 to 70°C
Transport	-25 to 70°C
Relative humidity	5 to 95%, non-condensing
Mechanical Properties	
Front	
Keypad overlay	
Material	Polyester
Design	Customized
Dimensions	
Width	197 mm
Height	140 mm
Depth	47.8 mm
weight	0.6 kg

2.3.1.2 Diagnostics LEDs:

The diagnostic LEDs are located on the back of the Power Panel. Figure 6 below displays the diagnostic LEDs available on the Display Module.

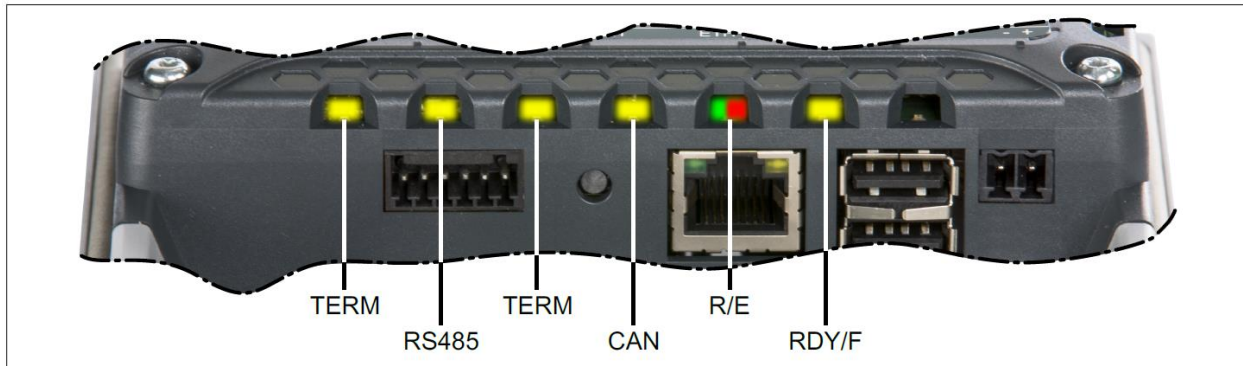

Figure 6: LEDs in Display Module

Table 2 below explains the LEDs and their Color Codes.

Table 2: Display Module LED Diagnostic

LED STATUS			
LED	Color	Status	Description
RDY/F	Yellow	On	Mode BOOT, SERVICE or DIAGNOSIS
		Blinking	LED "R/E" blinks red and LED "RDY/F" blinks yellow, when there is a license violation.
R/E	Green	On	Mode RUN: The application is running.
	Red	On	Mode BOOT, SERVICE or DIAGNOSIS
Blinking		LED "R/E" blinks red and LED "RDY/F" blinks yellow when there is a license violation.	
CAN (IF4)	Yellow	On	Data is transmitted via CAN bus interface IF4.
TERM (IF4)	Yellow	On	The integrated terminating resistor for the CAN bus interface (IF4) is switched on.
RS485 (IF5)	Yellow	On	Data is transmitted via CAN bus interface IF6.
TERM (IF5)	Yellow	On	The integrated terminating resistor for the RS485 bus interface (IF5) is turned on.

2.3.1.3 Reset Button / Operating Modes:

The Reset button is reserved for system operations such as setting the system into different boot modes. Do not use the reset button unless directed by Gardner Denver Service. Location of reset button is shown just for reference purpose below in Figure 7.

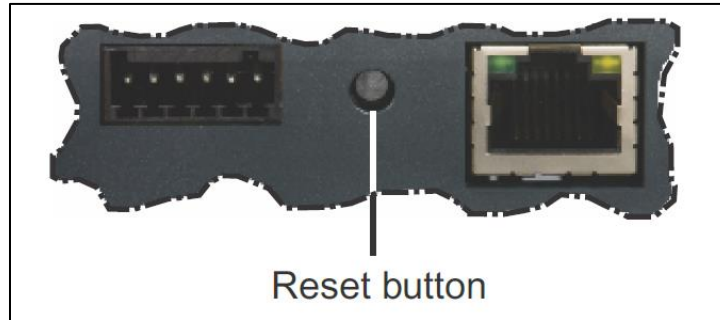

Figure 7: Reset Button

2.3.1.4 Connection Elements:

Below are the electrical connections available on the display unit in the Figure 8.

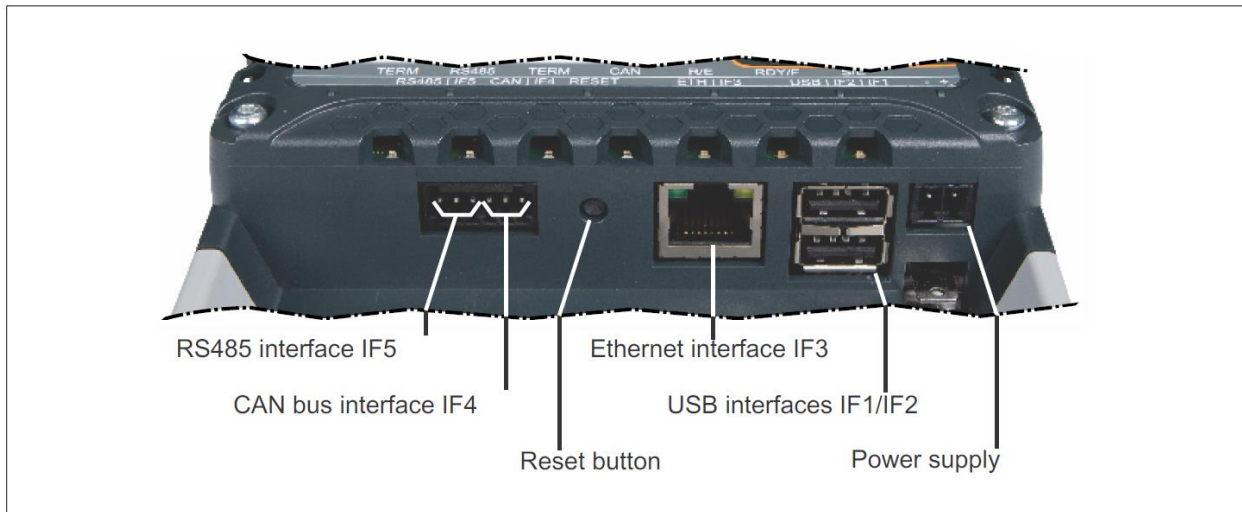

Figure 8: Connection Elements

CAN bus and RS485 Interface:

Figure 9 below shows the CAN bus and RS485 interface and Table 3 lists its pinouts.



Figure 9: CAN bus and RS485

Table 3: CAN bus and RS485

CAN BUS CONNECTION			
Terminal	Assignment	Interface	Function
1	CAN_H	IF4	CAN High
2	GND		Ground
3	CAN_L		CAN Low
4	DATA	IF5	Data
5	GND		Ground
6	DATA\		Data inverted

Ethernet Interface

Figure 10 below shows the Ethernet Interface and

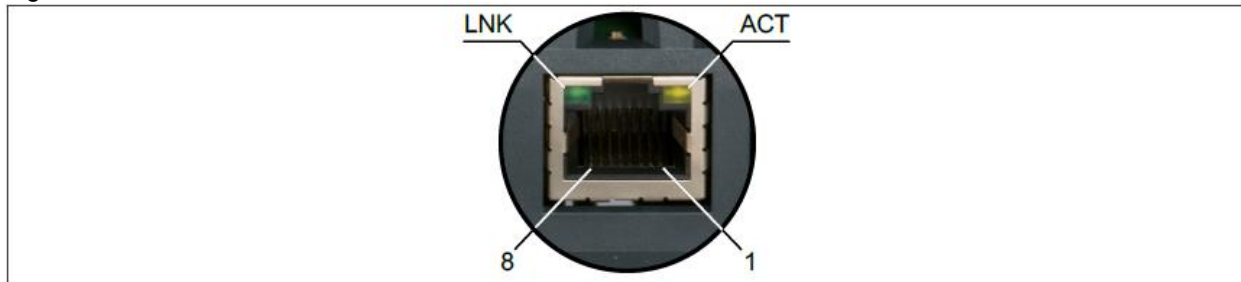

Figure 10: Ethernet Interface

Table 4 lists the Ethernet pinouts and signal diagnostics of the Ethernet port LEDs.

Table 4: Ethernet Interface and LED Diagnostics

ETHERNET CONNECTION			
Terminal	Assignment	Explanation	
1	RXD	Receive Signal	
2	RXD\	Received signal inverted	
3	TXD	Transmit signal	
4	Termination	Termination	
5	Termination	Termination	
6	TXD\	Transmit signal inverted	
7	Termination	Termination	
8	Termination	Termination	
Diagnostic LED			
LED	Color	Status	Description
LNK	Green	On	The link to the remote station is established
ACT	Orange	On	No Ethernet activity is taking place on the bus
		Blinking	The link to the remote station is established and Ethernet activity is taking place on the bus.

USB Interface:

The Power Panel is equipped with a USB 2.0 host controller with 2 USB interfaces. Figure 11 shows the USB interface and Table 5 list the USB data transfer rate and Power Supply.



Figure 11: USB Interface

Table 5: USB

USB Interface	
Transfer Rate	Low speed (1.5 MB/s), Full Speed (12 MB/s), High Speed (480 MB/s)
Power Supply	Max. 0.49 A per interface

Power Supply:

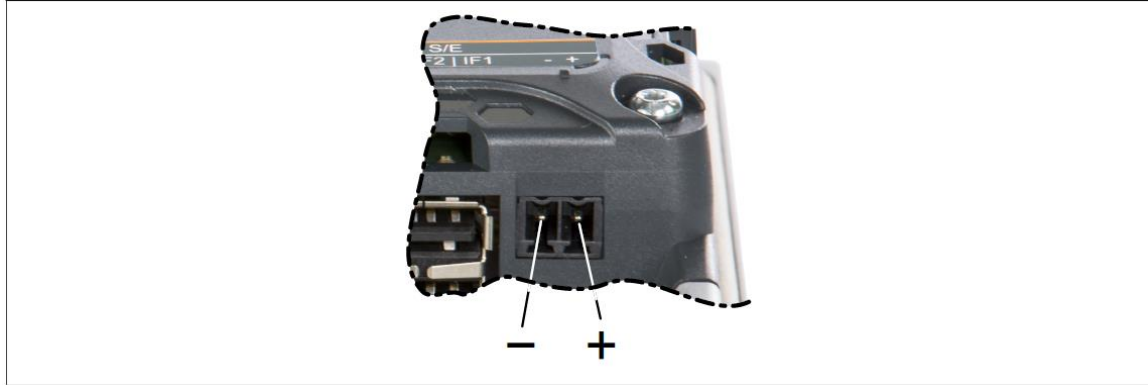

Figure 12: Power Supply interface

The Pinout for the power supply is listed Table 6 and printed on the back of the Power Panel. The Power Panel has reverse polarity protection that prevents the supply voltage from being connected incorrectly and damaging the device. Figure 12 above shows the Power Supply interface.

Table 6: Power Supply

Power Supply		
Terminal	Assignment	Explanation
1	+	24 VDC
2	-	GND

2.3.2 IO Module:

Gardner Denver uses a series of IO modules based on machine configuration.

2.3.2.1 Technical Data:

In the Table 7 below the technical data of the IO module is listed.

Table 7: IO Module

Technical Data				
Model Number	TEN014983	TEN014982	TEN014980	TEN014981
Short description				
I/O Module	digital inputs, 6 analog inputs, 12 digital outputs, 9 2 analog outputs, 9 PT1000/PTC, 1 PWM output	8 digital inputs, 6 analog inputs, 8 digital outputs, 9 1 analog output, 9 PT1000/PTC, 1 PWM output	8 digital inputs, 4 analog inputs, 12 digital outputs, 6 2 analog outputs, 6 PT1000/PTC, 1 PWM output	8 digital inputs, 3 analog inputs, 8 digital outputs, 4 PT1000/PTC, 1 PWM output
Interface	1x CAN bus, 2x RS485	1x CAN bus, 1x RS485	1x CAN bus, 2x RS485	1x CAN bus, 1x RS485
General Information				
Cooling	Passive			
LEDs				
Quantities	5			4
Status	Operating state, module status, RS485, CAN bus			
Certification	UL			

Input I/O Power Supply				
Connection designation	X07, X08, X09	X07, X08	X07, X08, X09	X07, X08
Input voltage	24 VDC -25%/+30%			
Fuse	Required line fuse: Max. 10 A, slow-blow			
Interfaces				
Interface IF2				
Conn designation	X02 RS485			
Signal	RS485			
Max. distance	1200 m			
Transfer rate	Max. 115.2 kbit/s			
Interface IF3				
Conn designation	X03 RS485	-	X03 RS485	-
Signal	RS485	-	RS485	-
Max. distance	1200 m	-	1200 m	-
Transfer rate	Max. 115.2 kbit/s	-	Max. 115.2 kbit/s	-
Interface IF4				
Conn designation	X0 CAN I/O			
Signal	CAN bus			
Max. distance	1000 m			
Transfer rate	500.0 kbit/s			
Digital Inputs				
Quantity	8			
Conn designation	X05, X06			
Nominal voltage	24 VDC			
Analog Inputs				
Quantity	6		4	3
Conn designation	X11			
Input	4 to 20 mA, 2-wire connections			
Resistance measurement temperature inputs				
Quantity	8X PT1000, 1X PTC		4X PT1000, 2X PTC	2X PT1000, 2X PTC
Conn designation	X12, X13			
Input	Resistance measurement for 2-wire connections			
Digital Output				
Quantity	12	8	12	8
Conn Designation	X07, X08, X09	X07, X08	X07, X08, X09	X07, X08
Nominal Voltage	24 VDC			
PWM Output				
Quantity	1			
Conn designation	X08			
Nominal voltage	24 VDC -25%/+30%			
Analog Output				
Quantity	2	1	2	1
Conn designation	X10			
Nominal voltage	4 to 20 mA with 2-wire connections			
Power Supply				
Conn designation	X01			
Voltage range	24 VDC -5%/+30%			
Power consumption	7 W	6.5 W	5.6 W	4.3W
Operating conditions				
Mounting orientation				
Horizontal	Yes			
Vertical	Yes			
Installation elevation above sea level				
0 to 2000 m	No limitation			
>2000 m	Reduction of ambient temperature by 0.5°C per 100 m			
maximum	4500 m			
Ambient Conditions				

Temperature	
Operation	-10 to 60°C
Storage	-20 to 70°C
Transport	-20 to 70°C
Relative humidity	
Operation	5 to 95%, non-condensing
Storage	5 to 95%, non-condensing
Transport	5 to 95%, non-condensing
Mechanical Properties	
Dimensions	
Width	190 mm
Height	198 mm
Depth	31 mm

2.3.2.2 Wiring:

Unshielded Lines:

- All unshielded lines must be relieved of tension by using a cable tie to secure to the grounding plate.

Shielded Lines:

- A central ground connection is available to effectively deflect interference. All cable shields must be connected to ground with good conductivity using a cable tie on the grounding plate or some other method.

Grounding:

- The connection to ground potential must be as short as possible and sufficiently strong ($\geq 4 \text{ mm}^2$).

Figure 13 explains the wiring diagram for the IO module. The following should be considered when wiring:

- Good Conductive connection to the metallic and grounded rear panel.
- Connect the braided shield wrapped with conductive foil to the grounding plate using cable ties.

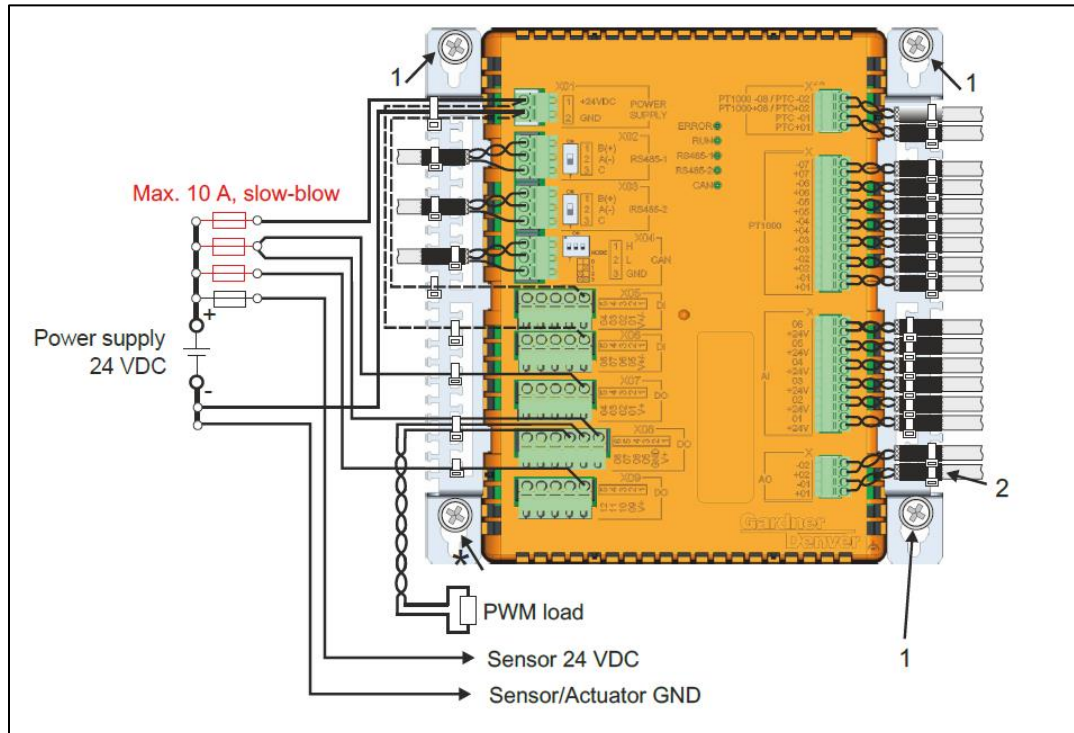



Figure 13: IO Module Wiring

2.3.2.3 Status LED:

Figure	LED	Color		
	ERROR	Red	On	Mode SERVICE
			Blinking	If LED "Error" blinks red and LED "RDY/F" blinks yellow, a license violation has occurred.
	RUN	Green	On	Application running
			Blinking	System startup boot mode: CPU initializing the application, all bus systems and I/O modules ¹⁾
			Double flash	Mode BOOT (during firmware update) ¹⁾
	RS485-1	Yellow	Off	No connection to the remote station.
			On	A connection to the remote station is established, but no RS485 activity is taking place.
			Blinking	A connection to the remote station is established, and RS485 activity is taking place.
	RS485-2	Yellow	Off	No connection to the remote station.
			On	A connection to the remote station is established, but no RS485 activity is taking place.
			Blinking	A connection to the remote station is established, and RS485 activity is taking place.
	CAN	Green	Off	No connection to the remote station.
			On	A connection to the remote station is established, but no CAN activity is taking place.
Blinking			A connection to the remote station is established, and CAN activity is taking place.	

1) This process can take several minutes depending on the configuration.

Figure 14: IO Module LED Status and Diagnostics

2.3.2.4 Connection Interface:

Power Supply (X01)

Figure 15 and Table 8 below shows the connector (GD Part TEN014969) used for power supply connections and pinout to signal details.

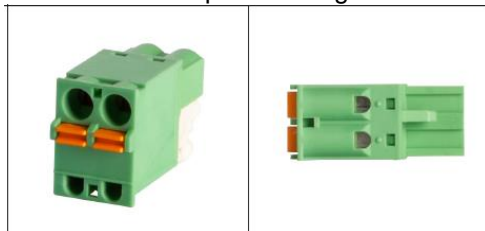

Figure 15: Power Supply (X01)

Table 8: Power Supply (X01)

Power Supply	
Pin	Signal
1	+24 VDC
2	GND

RS485 Interface (X02)

Only shielded cable must be used. Figure 16 below shows the connector (GD part TEN014970) used for RS485 connection and Table 9 for connector pin number to signal details.

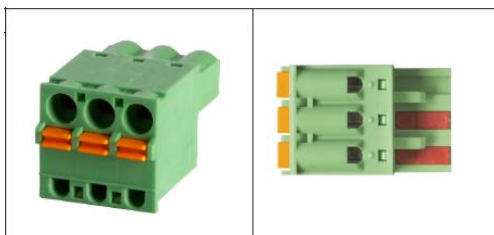

Figure 16: RS485 Interface (X02)

Table 9: RS485 (X02)

RS485 Connections	
Pin	Signal Name
1	B(+) - DATA
2	A(-) - DATA
3	C - GND

RS485 Interface (X03)

Only shielded cable must be used. Available only with IO Modules TEN014983 & TEN14980. Figure 17 below shows the connector (GD part TEN014971) used for RS485 connection and Table 9 for connector pin number to signal details.

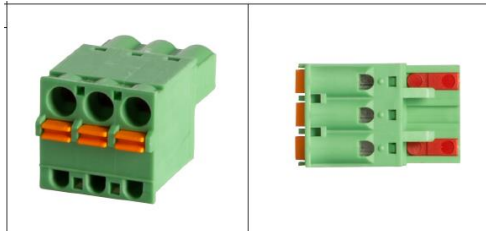

Figure 17: RS485 (X03)

CAN BUS (X04)

Only shielded cable must be used for CAN bus connection. Figure 18 below shows the connector (GD part TEN014972) used for CAN bus connection and Table 10 for connector pin to signal details.

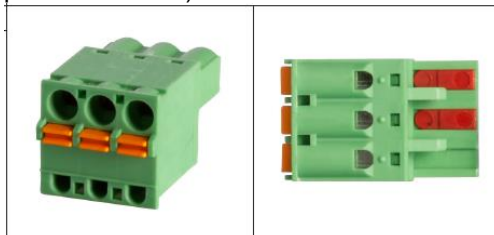

Figure 18: CAN bus (X04)

Table 10: CAN bus (X04)

CAN bus Connections	
Pin	Signal Name
1	CAN_H
2	CAN_L
3	GND

2.3.2.5 Terminal Block Connections:

For all cables, a mounting clip is provided on the left and right side of the housing for strain relief and shield connection. The use of cable ties is recommended.

Digital Input (X05)

Figure 19 below shows the connector (GD part TEN014973) used for X05 Digital Input connection and Table 11 for connector pin to signal details.

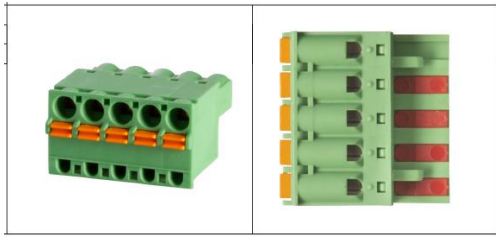

Figure 19: Digital Inout (X05)

Table 11: DI (X05)

Digital Input (X05) Connections	
Pin	Signal Name
1	V+ or GND
2	DI01 (counter input)
3	DI02
4	DI03
5	DI04

Digital Inputs (X06)

Figure 20 below shows the connector (GD part TEN014974) used for X06 Digital Input connections and Table 12 for connector pin to signal details.

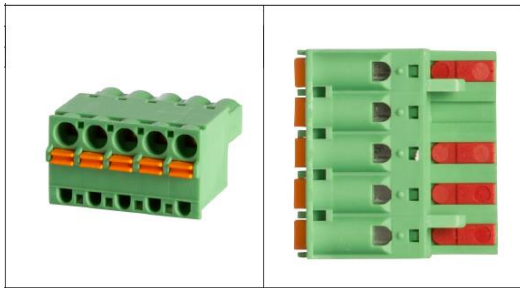

Figure 20: Digital Input (X06)

Table 12: DI (X06)

Digital Input (X06) Connections	
Pin	Signal Name
1	V+ or GND
2	DI05
3	DI06
4	DI07
5	DI08

Digital Outputs (X07)

Figure 21 below shows the connector (GD part TEN014975) used for X07 Digital Output connections and Table 13 for connector pin to signal details.

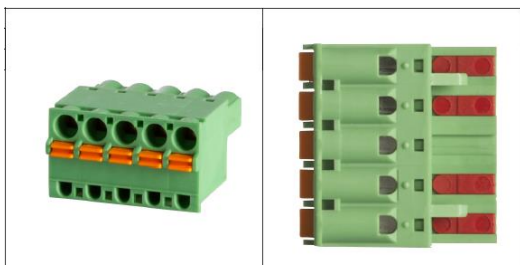

Figure 21: Digital Outputs (X07)

Table 13: DO (X07)

Digital Output (X07) Connections	
Pin	Signal Name
1	V+
2	DO01
3	DO02
4	DO03
5	DO04

Digital Outputs (X08)

Figure 22 below shows the connector (GD part TEN014977) used for X08 Digital Output connection and Table 14 for connector pin to signal details.

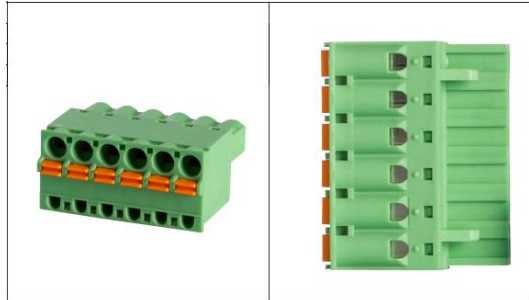

Figure 22: Digital Output (X08)

Table 14: DO (X08)

Digital Output (X08) connections	
Pin	Signal Name
1	V+
2	GND
3	DO05 (PWM output)
4	DO06
5	DO07
6	DO08

Digital Outputs (X09)

This option is available only in IO Module TEN014983 & TEN014980. Figure 23 below shows the connector (GD part TEN014976) used for X09 digital output connections and Table 15 for connector pin to signal details.

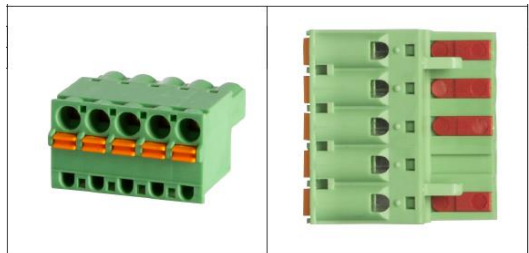

Figure 23: Digital Output (X09)

Table 15: DO (X09)

Digital Output (X09) Connections	
Pin	Signal Name
1	V+
2	DO09
3	DO10
4	DO11
5	DO12

Analog Outputs (X10)

Only shielded cable must be used for analog output connections. Figure 24 and Table 16 shows the connector (GD part TEN014961) used and connector pin to signal details for the systems with 2 analog output designs with IO module part numbers TEN014983 & TEN014980.

While, Figure 25 and Table 17 shows the connector (GD part TEN014960) used and connector pin to signal details for the systems with 1 analog output designs with IO Module # TEN014982.



Figure 24: Analog Output (X10)

Table 16: AO (X10)

Analog Output (X10) Connections	
Pin	Signal Name
1	+AO01
2	-AO01
3	+AO02
4	-AO02

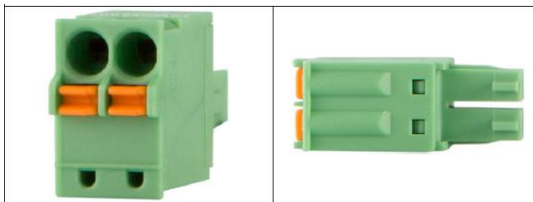

Figure 25: Analog Output (X10)

Table 17: AO (X10)

Analog Output (X10) Connections	
Pin	Signal Name
1	+AO01
2	-AO01

Analog Inputs (X11)

Only shielded cables must be used for analog input signals. Following are the details for analog inputs connection for 3 available options of 6, 4 & 3 analog inputs.

6 Analog Input Configuration

Available with IO module part numbers TEN014982 & TEN014983. Figure 26 below shows the connector (GD part TEN014967) and Table 18 connector pin to signal details for 6 analog input designs.

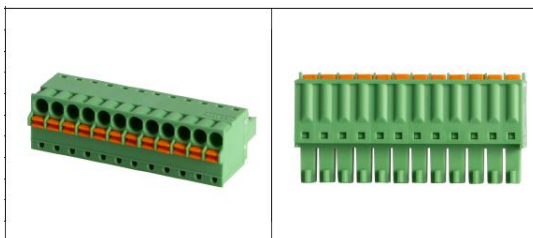

Figure 26: Analog Input (X11)

Table 18: AI (X11)

Analog Input (X11) Connections	
Pin	Signal Name
1	+24 V_AI
2	AI01
3	+24 V_AI
4	AI02
5	+24 V_AI
6	AI03
7	+24 V_AI
8	AI04
9	+24 V_AI
10	AI05
11	+24 V_AI
12	AI06

4 Analog Input Configuration

Available with IO module part number TEN014980. Figure 27 below shows the connector (GD part TEN014965) and Table 19 connector pin to signal details for 4 analog input designs.



Figure 27: Analog Input (X11)

Table 19: AI (X11)

Analog Input (X11) Connections	
Pin	Signal Name
1	+24 V_AI
2	AI01
3	+24 V_AI
4	AI02
5	+24 V_AI
6	AI03
7	+24 V_AI
8	AI04

3 Analog Input Configuration

Available with IO Module part number TEN014981. Figure 28 below shows the connector (GD part TEN014964) and Table 20 connector pin to signal details for 3 analog input designs.



Figure 28: Analog Input (X11)

Table 20: AI (X11)

Analog Input (X11) Connections	
Pin	Signal Name
1	+24 V_AI
2	AI01
3	+24 V_AI
4	AI02
5	+24 V_AI
6	AI03

PT1000/PTC Inputs (X12)

Only shielded cable must be used for PT1000/PTC inputs. Based on the system design there are three types of connections used for PT1000/PTC input signals. Following are the details.

Available with IO Module part numbers TEN014982 & TEN014983. Figure 29 shows the connector (GD part TEN014968) used and Table 21 have the connector pin to signal details.

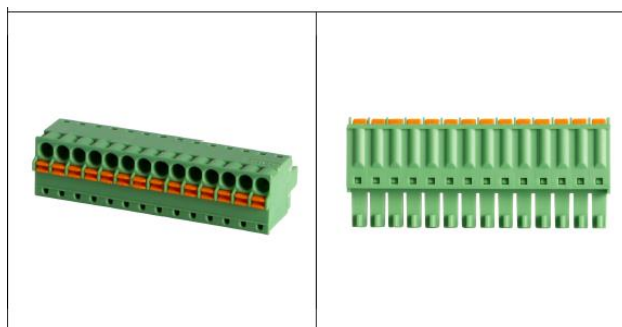

Figure 29: PT1000/PTC Inputs (X12)

Table 21: PT1000/PTC (X12)

PT1000/PTC (X12) Connections	
Pin	Signal Name
1	+PT1000 01
2	-PT1000 01
3	+PT1000 02
4	-PT1000 02
5	+PT1000 03
6	-PT1000 03
7	+PT1000 04
8	-PT1000 04
9	+PT1000 05
10	-PT1000 05
11	+PT1000 06
12	-PT1000 06
13	+PT1000 07
14	-PT1000 07

Available with IO Module part number TEN014980. Figure 30 shows the connector (GD part TEN014966) used and Table 22 have the connector pin to signal details.



Figure 30: PT1000/PTC Inputs (X12)

Table 22: PT1000/PTC (X12)

PT1000/PTC (X12) Connections		
Pin		Signal Name
1		+PT1000 01
2		-PT1000 01
3		+PT1000 02
4		-PT1000 02
5		+PT1000 03
6		-PT1000 03
7		+PT1000 04
8		-PT1000 04

Available with IO Module part number TEN014981. Figure 31 shows the connector (GD part TEN014963) used and Table 23 have the connector pin to signal details.

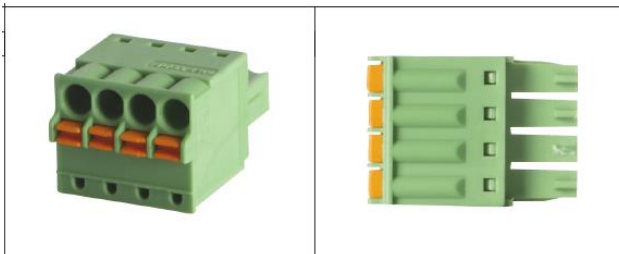

Figure 31: PT1000/PTC Inputs (X12)

Table 23: PT1000/PTC (X12)

PT1000/PTC (X12) Connections		
Pin		Signal Name
1		+PT1000 01
2		-PT1000 01
3		+PT1000 02
4		-PT1000 02

PT1000/PTC Inputs (X13)

Only shielded cable must be used for PT1000/PTC inputs. Based on the system design there are three types of connections used for PT1000/PTC input signals X13. Following are the details.

Available with IO Module part numbers TEN014981 & TEN014983. Figure 32 below shows the connector (GD part TEN014962) used and Table 24 have the connector pin to signal details.

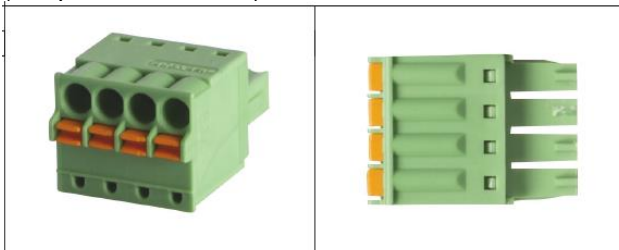

Figure 32: PT1000/PTC Inputs (X13)

Table 24: PT1000/PTC (X13)

PT1000/PTC (X13) Connections	
Pin	Signal Name
1	+PTC 01
2	-PTC 01
3	+PT1000 08/+PTC 02
4	-PT1000 08/-PTC 02

Available with IO Module part number TEN014982. Figure 33 shows the connector (GD part TEN014962) used and Table 25 have the connector pin to signal details.

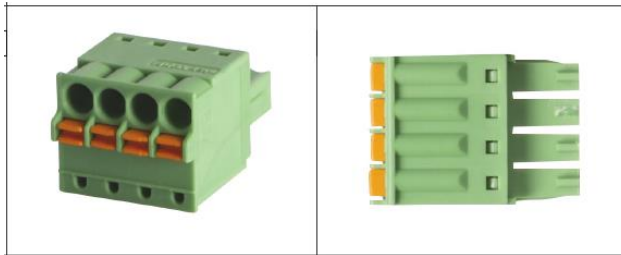

Figure 33: PT1000/PTC Inputs (X13)

Table 25: PT1000/PTC (X13)

PT1000/PTC (X13) Connections	
Pin	Signal Name
1	+PTC 01
2	-PTC 01
3	+PT1000 08
4	-PT1000 08

Available with IO Module part number TEN014980. Figure 34 shows the connector (GD part TEN014962) used and Table 26 have the connector pin to signal details.

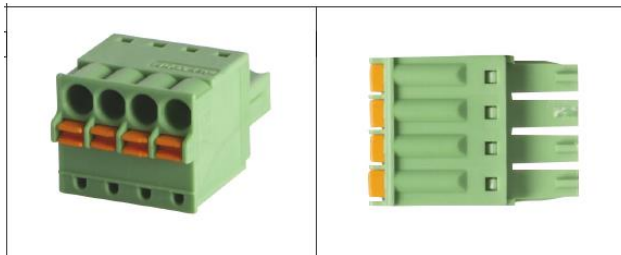

Figure 34: PT1000/PTC Inputs (X13)

Table 26: PT1000/PTC (X13)

PT1000/PTC (X13) Connections	
Pin	Signal Name
1	+PTC 01
2	-PTC 01
3	+PTC 02
4	-PTC 02

SECTION 3

QUICK START

This section provides the basic information on the controller so that the user can understand how to interact with and operate the machine. It focuses only on the common elements of the user interface and the settings and actions that are required to get the compressor running and producing air.

3.1 Common User Interface Elements

The user interface has common elements that are shared across all screens in the system. Understanding these elements will help improve interaction with the controller.

3.1.1 Common Navigation and Status Elements

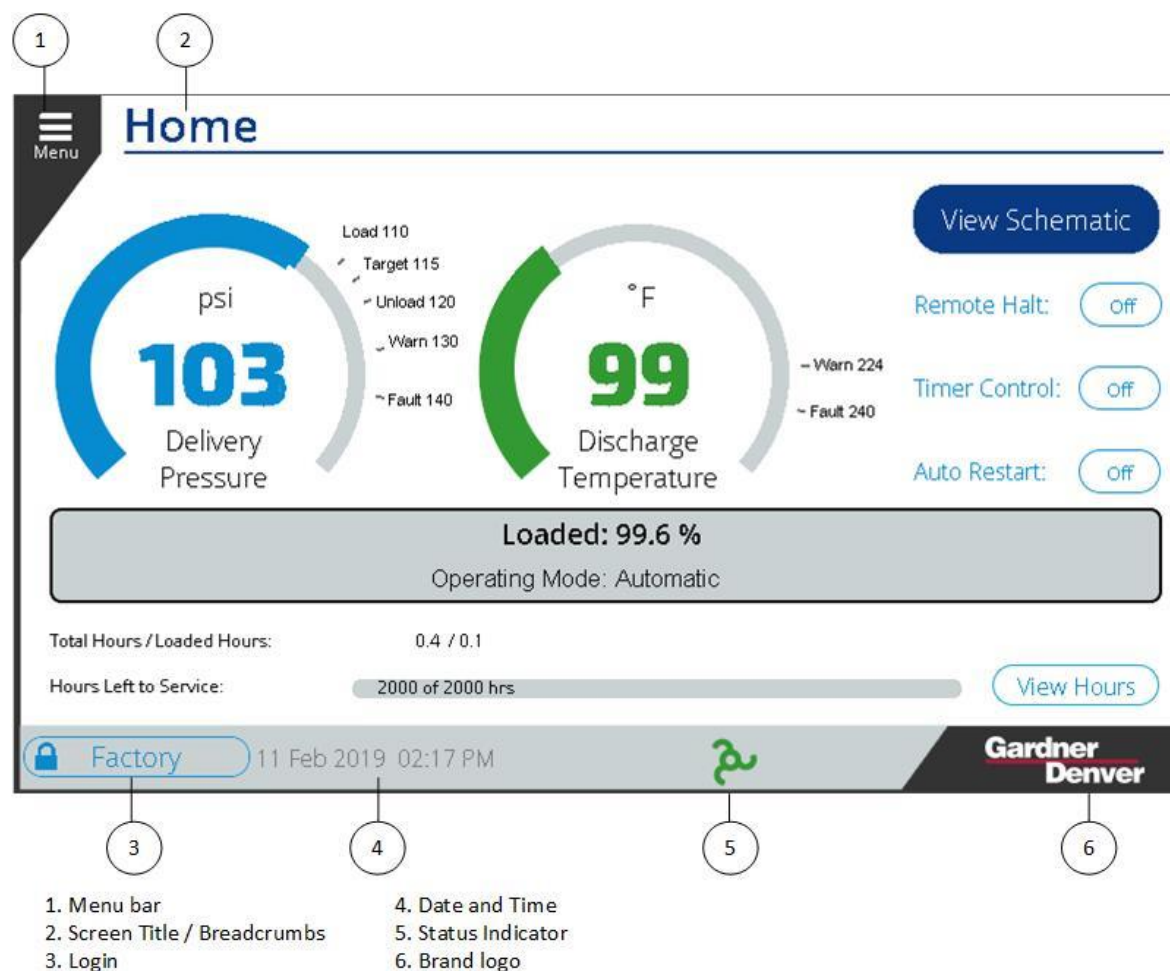





Figure 35: Common Screen Elements

The common status and navigation elements are shown in Figure 35 above and described below.

1. The Menu bar expands when pressed and provides a cascading navigation for all screens on the system.
2. The Screen Title / Breadcrumbs shows your current location within the user interface structure and also provides a navigation link back to the previous screen. For example, if the screen title displayed *Home > Dashboard*, pressing *Home* would navigate back to the home screen.

3. The **Login** button in the Status Bar indicates what access level is currently logged in to the system. Pressing it also provides a link to the Security screen, which is used to log in or out of the system.
4. The Date and Time display in the Status Bar displays the current date and time set on the controller. It is important to ensure that this is correct as it is used for several system functions including logging, trends, and timer control.
5. The Status indicator in the Status Bar is a quick reference to the status of the machine from any screen on the system. The status can take any of the following forms:
 -  - This image indicates that the machine is enabled. If the image is stationary, it indicates that the motor is not running, but could start at any time based on machine configuration and conditions. If the image is rotating, it indicates that the motor is currently running.
 -  - This image indicates that the machine is ready to start with user input but not enabled. The **Start** button must be pressed before the machine will be allowed to start.
 -  - This image indicates that the machine is shut down due to a fault condition. Refer to the Alarms system to determine the cause and resolve the fault condition.
6. The Gardner Denver Logo is present in the bottom right of every screen. Pressing this will navigate back to the Home screen from any screen in the system.

3.1.2 Buttons and Switches

The user interface includes several types of buttons and switches that can be used to interact with the system.

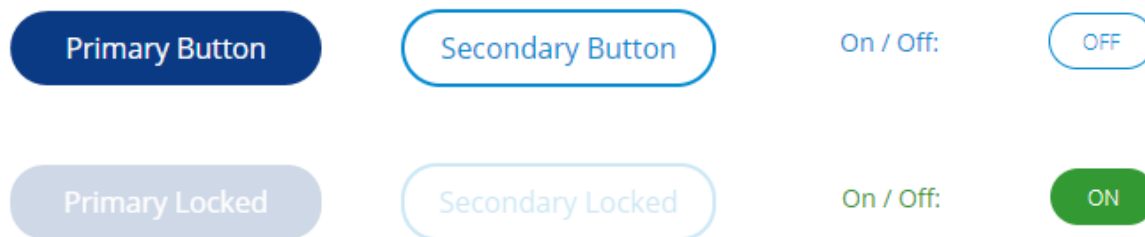

Figure 36: Button Styles

The various button and switch styles can be seen above in Figure 36 and are described in more detail below:

- Primary buttons are displayed in dark blue, and indicate the default or most common action(s) for the screen. For example, on a settings screen the **Save** button will be a primary button.
- The Secondary buttons are outlined in blue with white fill. These buttons represent the less common action(s) for a screen. For example, on a settings screen the **Cancel** button will be a secondary button.
- If a button is locked it will be shown as in the Primary Locked and Secondary Locked examples above. This usually indicates that the appropriate access level is not currently logged in, but it could

also be locked because the current machine status does not allow the action, or the action is not applicable to the machine configuration.

- On / Off switches are used for settings that can be enabled / disabled. If the item is disabled, or off, the switch will show “Off” in blue with a white background. If the item is enabled, or on, the switch will show “On” in white with a green background. Pressing the switch will toggle it to the opposite state.

Several screens on the system utilize tabs to organize and categorize the information. An example of these tabs is shown in Figure 37 below.



Figure 37: Tabs Style

The currently active tab is shown with a white background and blue text while inactive tabs are shown with blue background and white text. In the example above, “Digital Outputs” is the currently active tab. Pressing on a tab will cause it to become the active tab if it is not currently selected.

3.1.3 Scroll Elements

The system uses two types of control for scrolling the values shown on a screen.











The first scroll element is shown in Figure 38 below. It operates much like a scroll bar on any other application. Pressing the **V** on the bottom of the scroll bar will move the screen down. You can also drag the scroll position indicator to move the position.







Figure 38: Scroll Bar Example

The second type of scroll element is shown below in Figure 39. It is used for screens where there is a need to move with more precision than with the scroll bar, for example when there is a long list of individual elements. Pressing the single arrows will move the selection up or down one element. For example, pressing the down arrow in the example below will select the next oldest entry in the Alarm History. Pressing the double arrow buttons will jump down or up several selections to allow for quickly scrolling multiple entries.

Alarm History

Alarm	Timestamp	Code	Message
	2019-02-06 14:56:23	S.3	Service Due: Oil Change
	2019-02-06 14:54:21	C.21	Error registering all datapoints for value change monitoring
	2019-02-06 14:51:07	C.21	Error registering all datapoints for value change monitoring
	2019-02-06 14:50:45	P.0	Power loss
	2019-02-06 14:36:46	P.0	Power loss
	2019-02-05 20:28:39	P.204	[Reservoir Pressure] Input is above the Warning Limit
	2019-02-05 20:28:38	P.204	[Reservoir Pressure] Input is above the Warning Limit
	2019-02-05 20:28:38	P.204	[Reservoir Pressure] Input is above the Warning Limit
	2019-02-05 16:25:37	C.21	Error registering all datapoints for value change monitoring
	2019-02-05 16:25:30	C.21	Error registering all datapoints for value change monitoring

Info
Active Alarms

Figure 39: Scroll Button Example

3.1.3 Settings and Input Elements

The system uses several styles for elements that are used to show and change settings or other user interface controls.

3.1.3.1 Dropdown Boxes

Dropdown selections allow the user to select an item from a pre-defined list of available options. An example is shown in Figure 40 below. To deploy the dropdown, press on the value that is shown (**Automatic** in the example below). With the dropdown deployed, you can change the selection by pressing on the option that you would like to select. Note that options that are not available for your current configuration are shown in light gray as can be seen with the **Low Demand** setting in the **Operating Mode** dropdown.

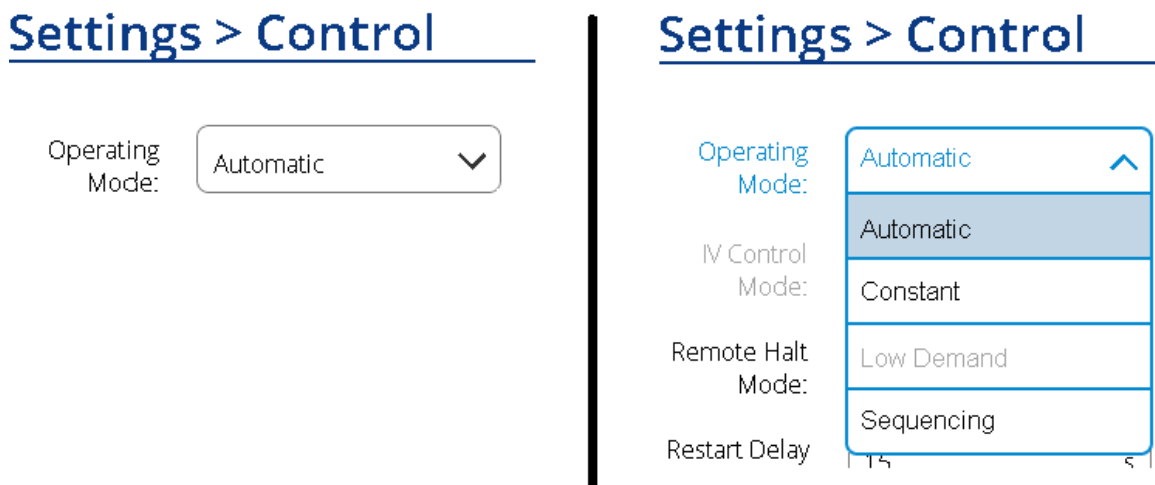

Figure 40: Dropdown Box

3.1.3.2 Value Settings

Value boxes display a numerical or text value. Pressing on the box will bring up a number or text entry keypad. An example of a numerical value setting and keypad is shown below in Figure 41.

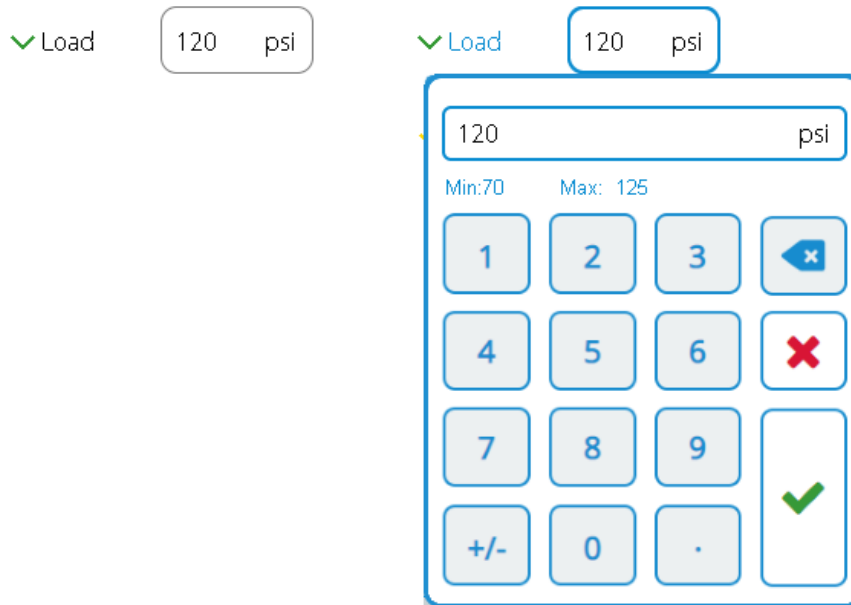





Figure 41: Number Keypad

Keypad entry operation is described below:

- For inputs that have a maximum and minimum valid range, the keypad will display the valid input range as shown in Figure 41.
- To change the value, start typing a new value and it will overwrite the existing setting.

- To commit changes and close the keypad, press  .

- To close the keypad without saving changes, press  .

- To delete the most recently entered number, press  .

An example of a text entry keypad is shown in Figure 42 below. The operation of this keypad and its controls are identical to the number keypad described above.

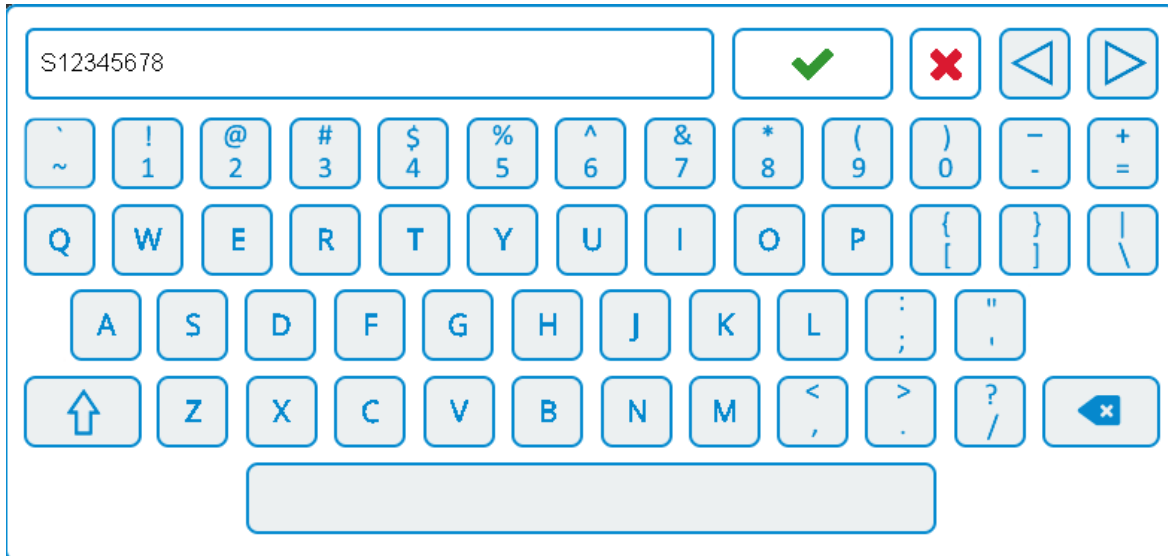

Figure 42: Text Keypad

3.2 Home Screen

The Home screen is the primary screen for operation of the machine. It displays machine status messages, pressure and temperature readings, essential settings, and maintenance status. Figure 43 below shows the Home screen with each element defined.

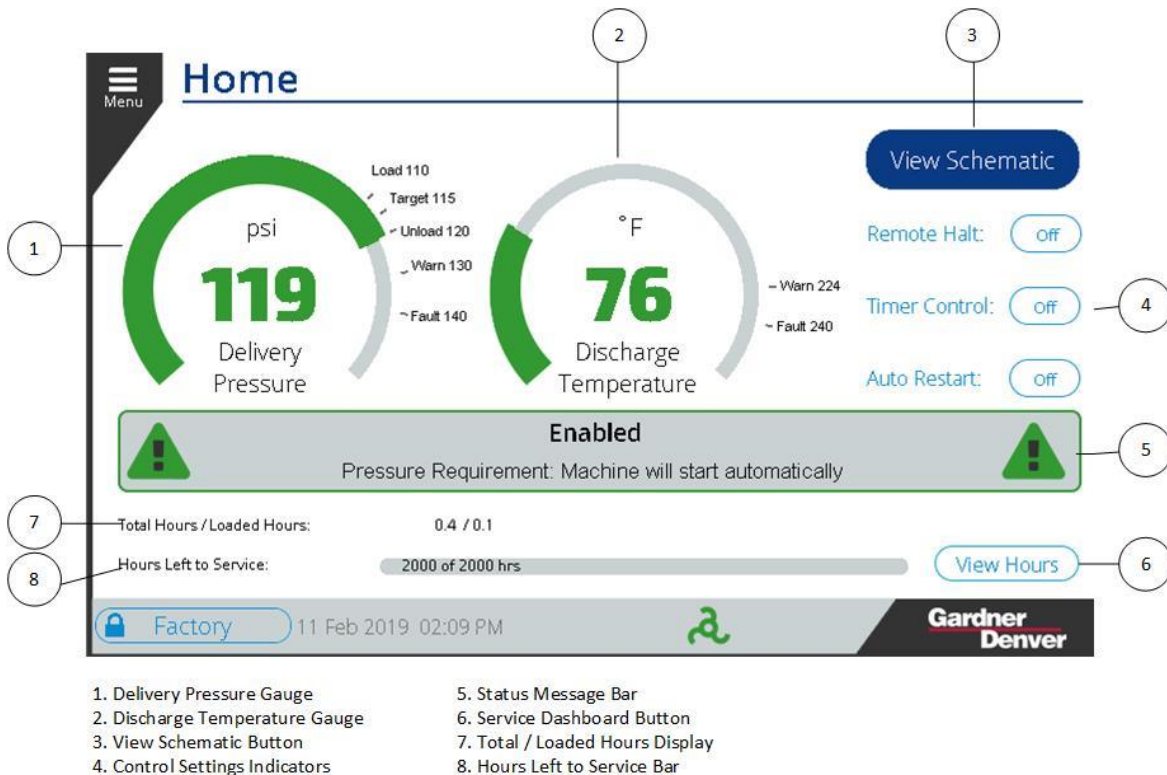

Figure 43: Home Screen Elements

Additional details on each of the home screen elements are provided below:

1. The Delivery Pressure gauge shows the current machine delivery pressure as well as the currently active pressure band used for control. The color of the gauge and pressure display also changes to indicate the region that the pressure is currently in.

- If the pressure is below the load pressure setting, it will be displayed in blue:



- If the pressure is above the Load pressure and less than the Warning pressure setting, it will be displayed in green:



- If the pressure is between the Warning and Fault pressure settings, it will be displayed in yellow:

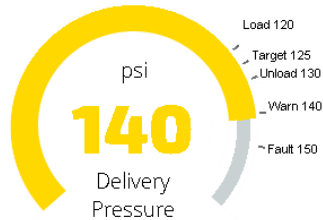





- If the pressure is above the Fault pressure setting, it will be displayed in red:



2. The Discharge Temperature gauge shows the compressor airend discharge temperature.

- If the temperature is below the Minimum Start Temperature setting, it will be displayed in red.
- If the temperature is between the Minimum Start Temperature setting and 3 °C (5.4 °F) above the Minimum Start Temperature, it will be displayed in yellow.
- If the temperature is above the Minimum Start Temperature plus 3 °C (5.4 °F) and below the Warning temperature setting, it will be displayed in green.
- If the temperature is above the Warning temperature setting and below the Fault temperature setting, it will be displayed in yellow.
- If the temperature is above the Fault temperature setting, it will be displayed in red.

3. The **View Schematic** button is used to navigate to the Schematic screen. This provides a graphical representation of the machine operation and status.
4. The Control Settings Indicators area of the screen shows the current status of the control settings that control the machine operation and starting / stopping of the machine. Pressing anywhere within this area of the screen will navigate to the Control Settings screen which can be used to adjust these settings.
 - **Remote Halt:** The Remote Halt indicator reflects the setting of Remote Halt Mode on the control settings screen. If the Remote Halt Mode is Disabled, the indicator will show Off. If the remote halt mode is Timed or Immediate, the indicator will show On.
 - **Timer Control:** The Timer Control indicator reflects the setting of Timer Start Enable on the Control Settings screen.
 - **Auto Restart:** The Auto Restart indicator reflects the setting of Auto Restart Enable on the Control Settings screen.
5. The Status Message Bar displays information about the current machine status. If a fault or warning is active, red or yellow attention indicators will illuminate on the bar.
6. The **View Hours** button links to the Service Dashboard screen, which can be used to view, configure, and reset all of the maintenance timers on the system
7. The Total / Loaded hours display shows the current total and loaded hours of the machine.
8. The Hours Left to Service bar graph indicates the value of the minimum service timer. The colors and fill of the graph change to give a visual indication of the length of time until next service as described below:
 - 100% service life, timers just reset:

 - Service life greater than 350 hours:

 - Service life of 350 hours or less:

 - Service life of 175 hours or less:

3.2.1 Screen Saver

After the controller has been sitting idle without any human interaction for 10 minutes a screen saver will show on the display like in Figure 44 below. This page shows the current status of the machine and important information is displayed in large text so a tech can view it from a distance away from the machine. Here the delivery pressure and the discharge temperature is shown. It can be seen that the machine is currently enabled and ready to be started in the first image and running and loaded in the second image. To exit the screen saver and return to the home screen, touch anywhere on the screen.



Figure 44: Screen Saver

3.3 Schematic Screen

The Schematic screen shows a graphical summary of the machine operation, status, and data. It is accessed from the Home screen by pressing the **View Schematic** button. Figure 45 below shows the main Schematic screen view with a summary of the elements.

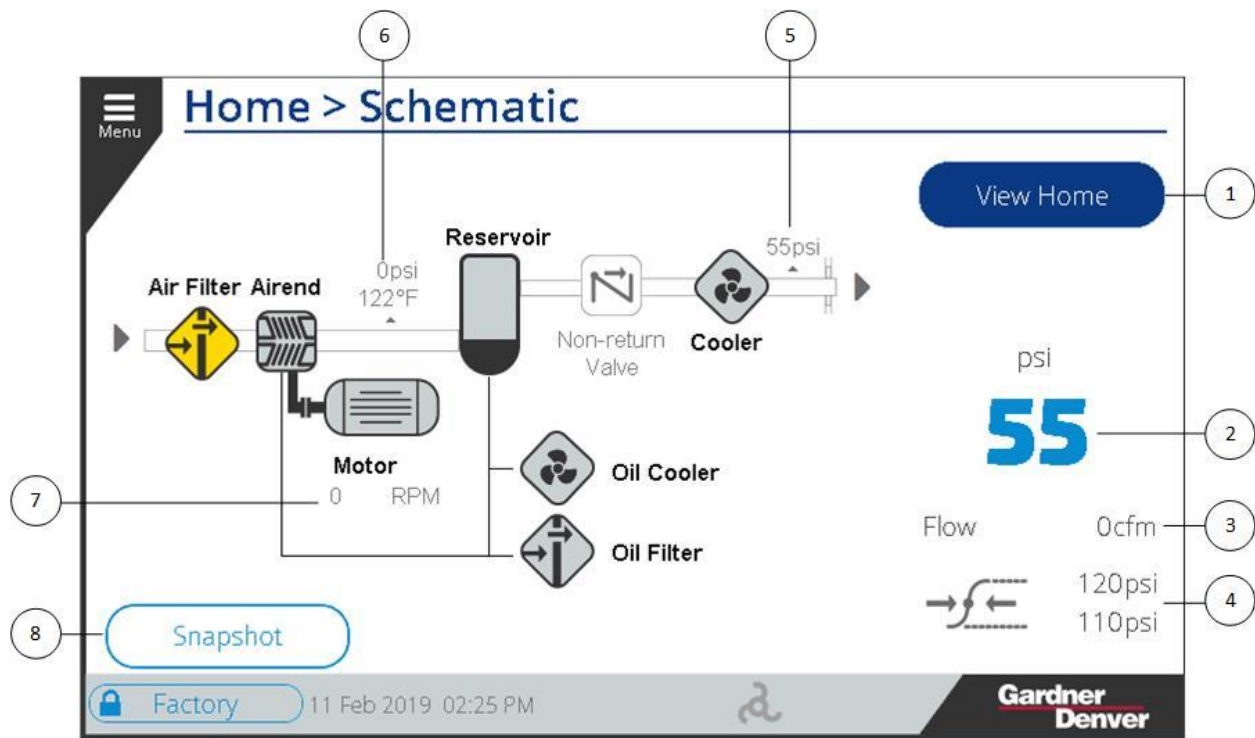

- | | |
|--------------------------|---|
| 1. View Home Button | 5. Delivery Pressure |
| 2. Delivery Pressure | 6. Reservoir Pressure and Discharge Temperature |
| 3. Estimated Volume Flow | 7. Motor RPM (Variable speed) |
| 4. Pressure Setpoints | 8. Snapshot Button (only Technician and Factory access) |

Figure 45: Schematic View

The main elements of the schematic view are described below:

1. The **View Home** button returns the user to the Home screen.
2. The Delivery pressure is shown in large text on the right of the screen in the default view.
3. The estimated Volume Flow is shown below the discharge pressure on the default view.
4. The current pressure set points for Load and Unload pressure are shown below the Volume Flow on the right side of the default view.
5. The Delivery Pressure is shown to the right of the Cooler element on the schematic.
6. The readings between the Airend and the Reservoir show the Reservoir Pressure and Discharge Temperature of the machine.
7. On variable speed machines, the Motor RPM is displayed below the Motor element.
8. The **Snapshot** button is visible when logged in as Technician or Factory. Pressing this button causes an entry to be added to the Alarm History log for a manual snapshot event. Use this feature to capture readings for later analysis using the **Info** button on the Alarm History screen.

Each of the bold items on the schematic can be pressed to display more information about the element. For example, pressing on the **Airend** will display the airend discharge temperature and inlet valve state as shown in Figure 46 below.

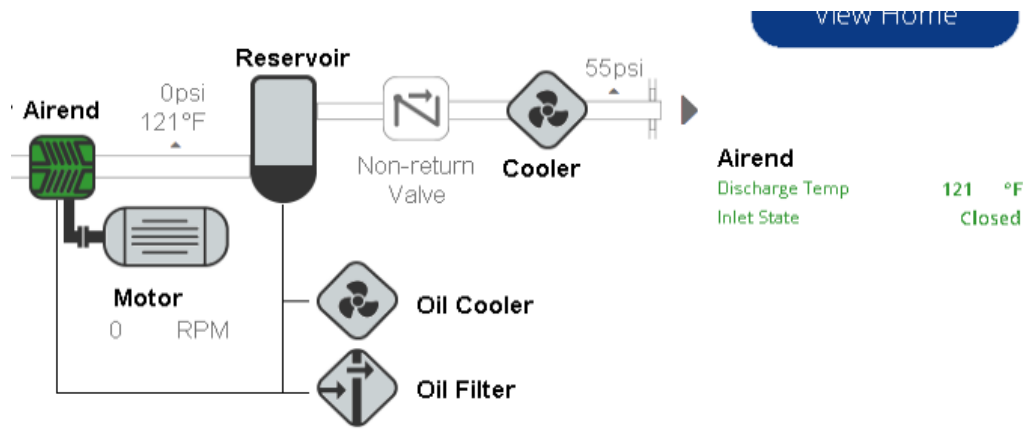

Figure 46: Airend Focus View

If an element of the machine is in a warning or fault state, the element will be highlighted in yellow or red accordingly. For example, in Figure 47 below, the air filter service timer has expired, so the **Air Filter** element is highlighted in yellow. Pressing the **Air Filter** element on the screen shows the value of the service timer highlighted in yellow since it is the source of the warning.

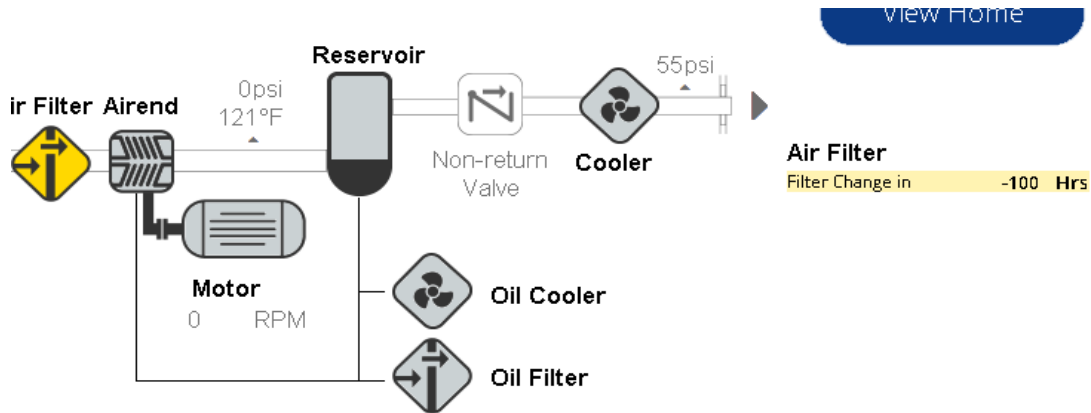

Figure 47: Air Filter Focus with Warning

The values available at each element on the schematic are shown below in Table 27.

Table 27: Values of Schematic Elements

Air Filter	Airend	Motor	Reservoir	Cooler	Oil Cooler	Oil Filter
Air Filter Hours	Discharge Temperature	State (FS)	Reservoir Pressure	Delivery Pressure	None on current machine	Oil Filter Hours
	Inlet State	Motor RPM (RS)	Differential Pressure			Oil Change Hours
		Motor Hz	Separator Change Hours			
		Motor Current (RS)	Separator Pressure			
		Heatsink Temp (RS)	Separator Temp.			
		DC Bus Volts (RS)				
		Motor Lube Hours				

3.4 Navigation Menu

The Main Menu provides quick access to all screens on the system. Subcategories of the Main Menu will expand when selected if there are multiple screens available.

Pressing the **Menu** button  in the upper left corner of the screen will deploy the Menu, as shown in Figure 48 below. With the Menu deployed, press the **X** at the top of the Menu to hide the Menu.

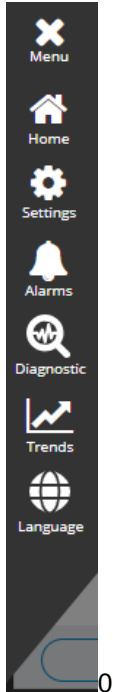

Figure 48: Menu Deployed

The following screens and categories are available through the Menu:

- **Home:** This button links to the Home screen.
- **Settings:** Deploys cascading Settings Menu structure to view or modify any setting on the system.
- **Alarms:** Deploys cascading Alarms Menu with links to the Active Alarms and Alarm History views.
- **Diagnostics:** Deploys the cascading Diagnostics Menu structure. This area of the user interface allows viewing information about the operation of the controller and the machine for technical and troubleshooting use.
- **Trends:** This button links to the Trends screen, which allows viewing graphs of the machine operation over time.
- **Language:** This button provides one-click access to the Menu for setting the Language on the controller. This prevents the need to navigate to the appropriate settings screen if the controller is set to a language that the user cannot read.

As you navigate through the system, the Menu will cascade to the right to indicate your current position. For example, Figure 49 below shows the view of the Menu after selecting **Settings**, then **Configuration**.

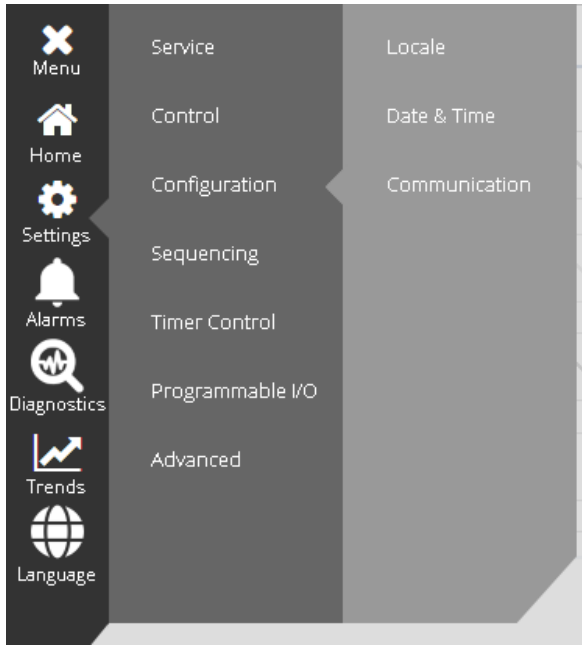

Figure 49: Menu Cascade

3.5 Logging In

Before making any changes to the settings on the controller, you must log in with an appropriate access level. The current access level is indicated by the **User** button on the **Status Bar** in the bottom left of the screen as shown in Figure 50 below. The text of the button indicates the current access level.



Figure 50: Login Button

Pressing this button will navigate to the Security screen as shown in Figure 51 below.

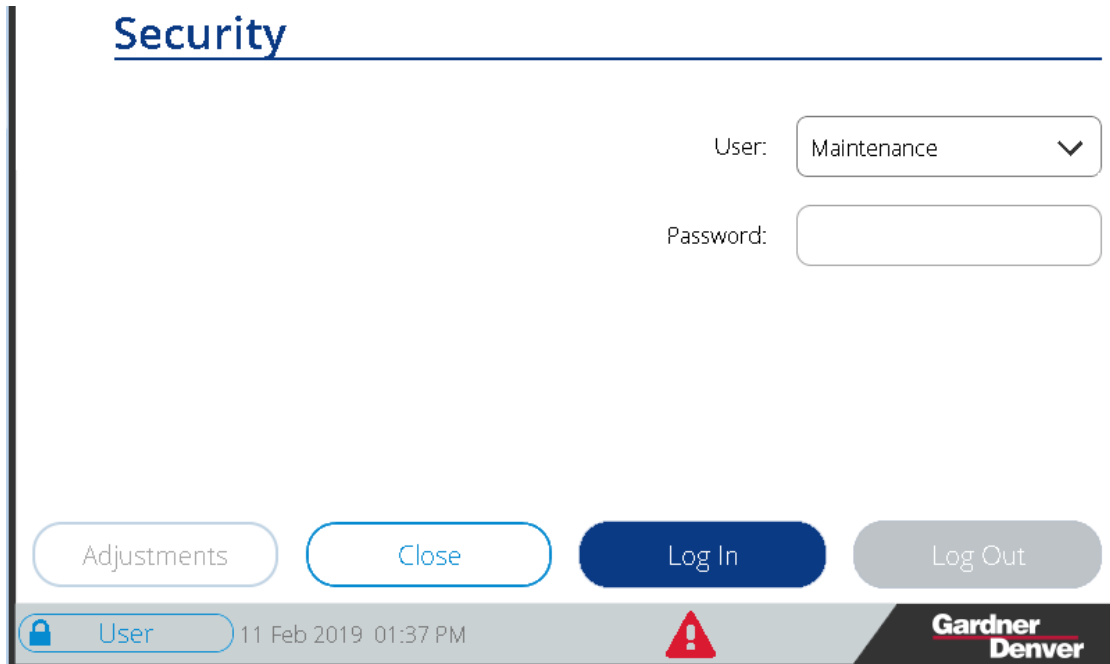

Figure 51: Security Screen

To log in, select the desired access level from the **User** dropdown, enter the password into the **Password** field, and press the **Log In** button.

The available access levels and default passwords are shown below in Table 28 below.

Table 28: Access Levels

User Level	Default Password	Description
User	None	Default level, limited access
Maintenance	407	End user. Basic settings access and ability to reset service timers.
Technician	8412	Advanced access targeted towards distributors and service technicians.
Factory	Contact Gardner Denver	Full access to all settings and features. The password rotates automatically throughout the life of the machine. It may not be changed. This password should only be required under unusual circumstances and must be provided by Gardner Denver Technical Support.

Note that the passwords can be changed from the default using the **Adjustments** button on the left of the screen once logged in.

After logging in, press the **Close** button to return to the previous screen.

3.6 Setting Up

Before running the machine, there are several basic configuration settings that may need to be changed.

3.6.1 Controller Configuration

Basic controller configuration is located under the Settings > Configuration menu as shown in Figure 52.

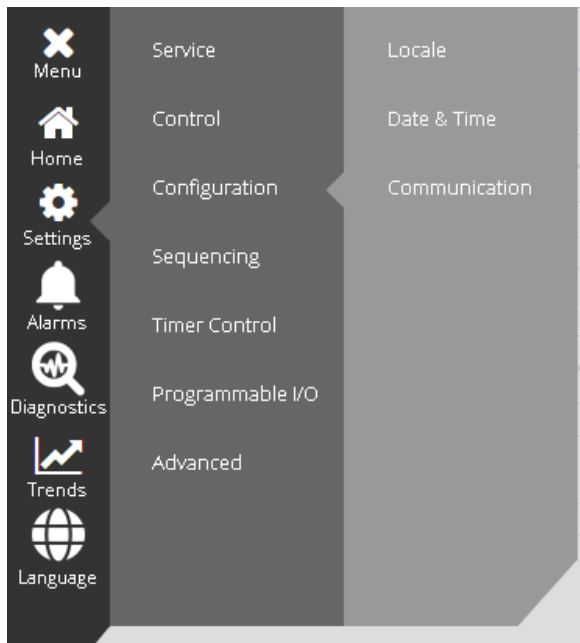

Figure 52: Configuration Menu

First, ensure that the units are set as desired by selecting the **Locale** link from the Configuration menu. The Pressure, Temperature, and Flow Units can be set individually as shown in Figure 53. If the Language needs to be changed, it may be changed by selecting the **Language** button below the units.

Configuration > Locale

Pressure Units:	<input type="text" value="psi"/>
Temperature Units:	<input type="text" value="°F"/>
Flow Units:	<input type="text" value="cfm"/>
	<input type="button" value="Language"/>
<input type="button" value="Cancel"/>	<input type="button" value="Save"/>

Figure 53: Locale Configuration

It is important to verify that the Date, Time, and Time zone are set properly for the site. The date and time are relied on for logs, timer control, trends, etc. Setting the time zone properly ensures that daylight savings time adjustments will be accounted for automatically. The Date and Time Configuration screen is shown in Figure 54.

Configuration > Date & Time

Set Date and Time

Year	Month	Day	Hour	Minute	Second
<input type="text" value="2019"/>	<input type="text" value="2"/>	<input type="text" value="11"/>	<input type="text" value="14"/>	<input type="text" value="45"/>	<input type="text" value="26"/>
Timezone					
<input type="text" value="(UTC - 06:00) Central Time (USA & Canada)"/>					

Figure 54: Date and Time Configuration

To set the time zone, click on the **Timezone** box and use the selector dialog that appears to select the appropriate time zone for your region as shown in Figure 55.

Date & Time > Timezone

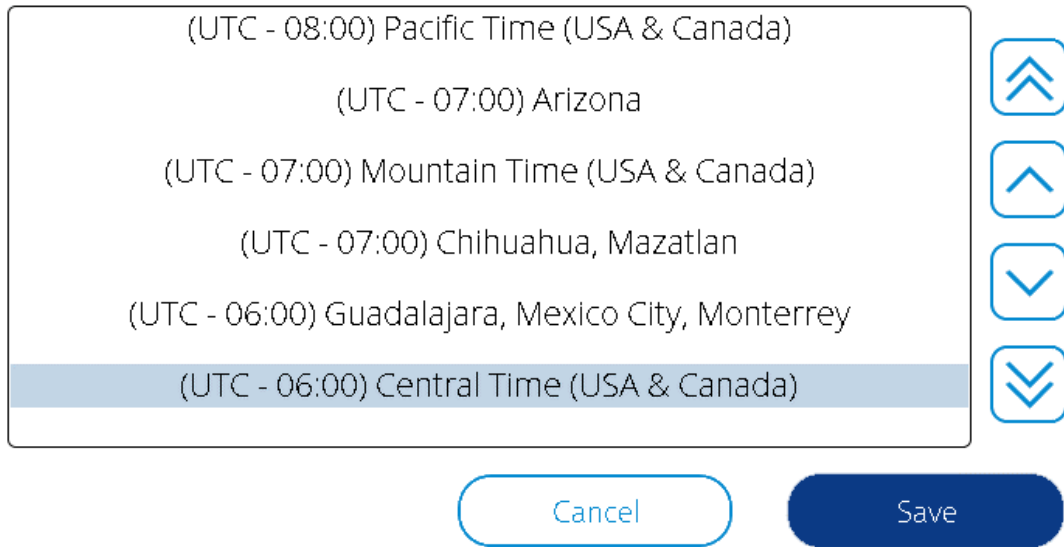

Figure 55: Timezone Selection

3.6.2 Control Settings

The settings under the Control Menu determine how the machine operates to match the process requirements of the customer. The default settings of the machine are acceptable for most installations. However, if the Pressure Band displayed on the gauge on the Home screen does not match the desired pressure range for the site, the Pressure Band must be adjusted.

To adjust the Pressure Band, navigate to Settings > Control as shown in Figure 56. Then, press the **Adjust** button next to p1 Pressure Band.

Settings > Control

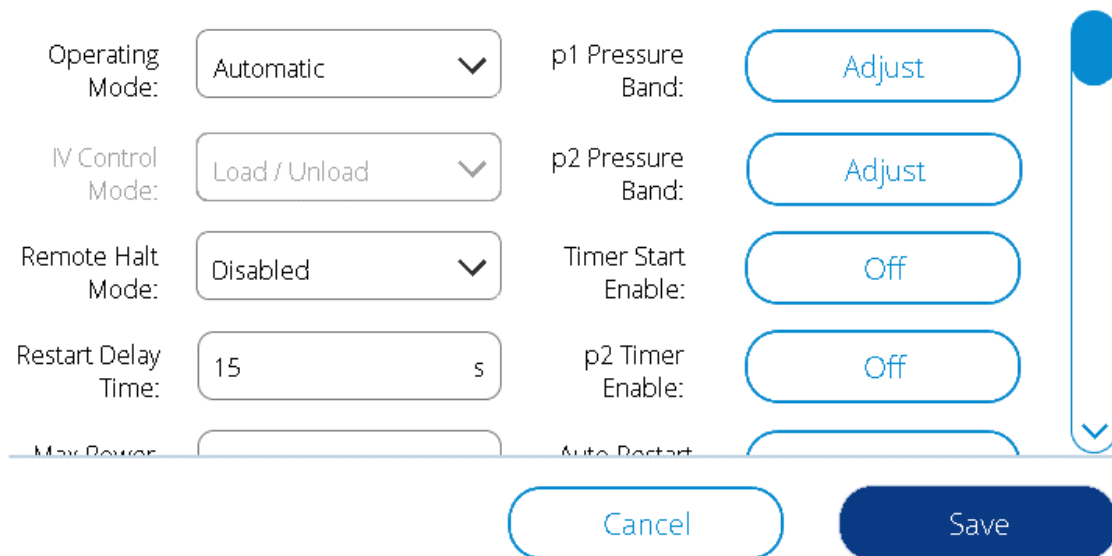

Figure 56: Control Settings

The p1 Pressure Band Setting screen is shown in Figure 57 below. The bar graph gives a visual indication of the pressure band settings. Press the numerical value boxes to make adjustments as needed. Note that the minimum and maximum values that will be allowed for each box will change dynamically based on the design pressure of the machine as well as the values of the other settings. For example, to increase the Load pressure to 126 PSI in Figure 57, the Unload pressure and Target pressure would first need to be increased.

Control > Pressure P1 Band Setting

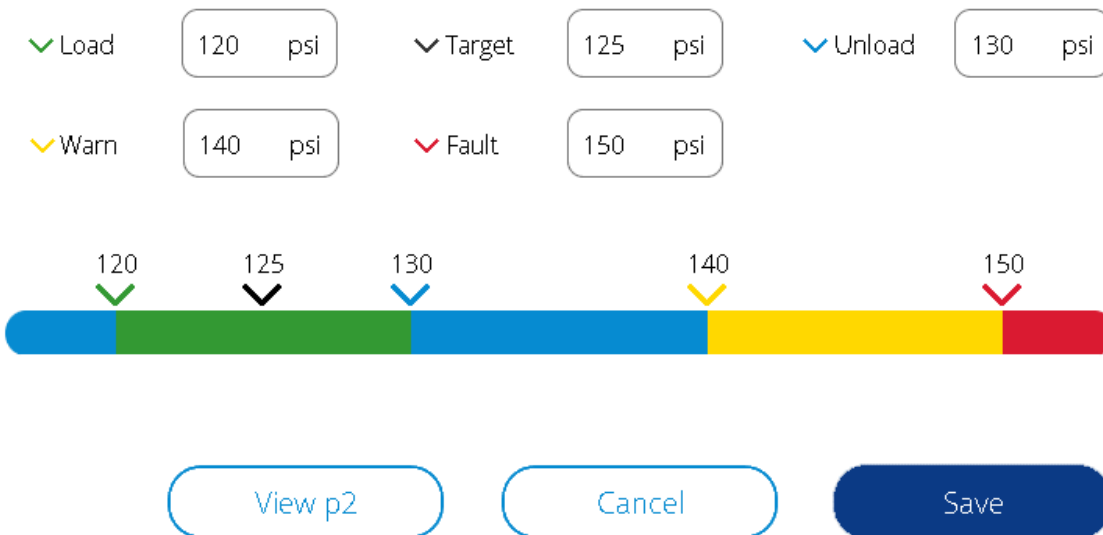

Figure 57: Primary Pressure Band Setting

Once you are satisfied with the pressure band settings, press the **Save** button to commit the changes.

One thing to note, when the certain machine settings are changed a (*) will come up next to the changed setting indicating the changes are made and pending to save. Hit the **Save** button at bottom to implement the changes and the (*) will go away when changes are confirmed.

3.7 Clearing Alarms

If there are any faults present on the machine, they must first be cleared to allow the machine to be started. If the machine has been powered on recently and Auto Restart is not enabled, a Power Loss fault will be present.





If a fault is active on the machine, the Active Alarms screen can be accessed by pressing on the Alarm triangle on the Message Status Bar on the Home screen, or by navigating to Alarms > Active Alarms through the Menu. The Active Alarms screen is shown in Figure 58.

If the alarm icon in the Alarm column is an outline, as shown in Figure 58, the alarm is no longer active and may be reset. If the alarm icon is solid (), the fault is still active and the condition must be resolved before it can be cleared.

Once all faults have been resolved, press the **Reset All** button, which will move the alarms to the Alarm History screen. Once all faults have been reset, return to the Home screen.

Active Alarms

Alarm	Timestamp	Code	Message
	2019-02-11 13:28:01	P.0	Power loss

InfoAlarm HistoryReset All

Figure 58: Active Alarms Screen

3.8 Jogging the Motors

If this is the first time that the machine has been started after being connected to power, the motors must be jogged to verify correct rotation. To do this, you must be logged in as a Technician. After logging in, navigate to Diagnostics > Jog Motors. The Jog Motors screen is shown in Figure 59.

Diagnostics > Jog Motors

Jog Duration

0.2 s 

Selected Motor

Compressor Motor 

Jog Delay

Compressor Motor

Fan Motor

Start Jog

Figure 59: Jog Motors Screen

Select the desired jog duration and select Compressor Motor or Fan Motor from the dropdown as shown. You will need to jog both individually to verify correct rotation. The Jog Delay field allows you to delay the start of the jog from the time that you press the **Start Jog** button. This is to allow you time to get into a position to view the rotation before the motor is started. Note that the controller will only allow one jog every 10 seconds and will disable the **Start Jog** button during this time period.

After correct rotation has been verified, return to the Home screen and proceed to operate the compressor.

3.9 Operating the Compressor

The compressor is now ready to operate. This section gives a basic overview of how to operate the machine.

3.9.1 Starting

From the home screen, the Message Status Bar should display “Ready to Start” as shown in Figure 60.

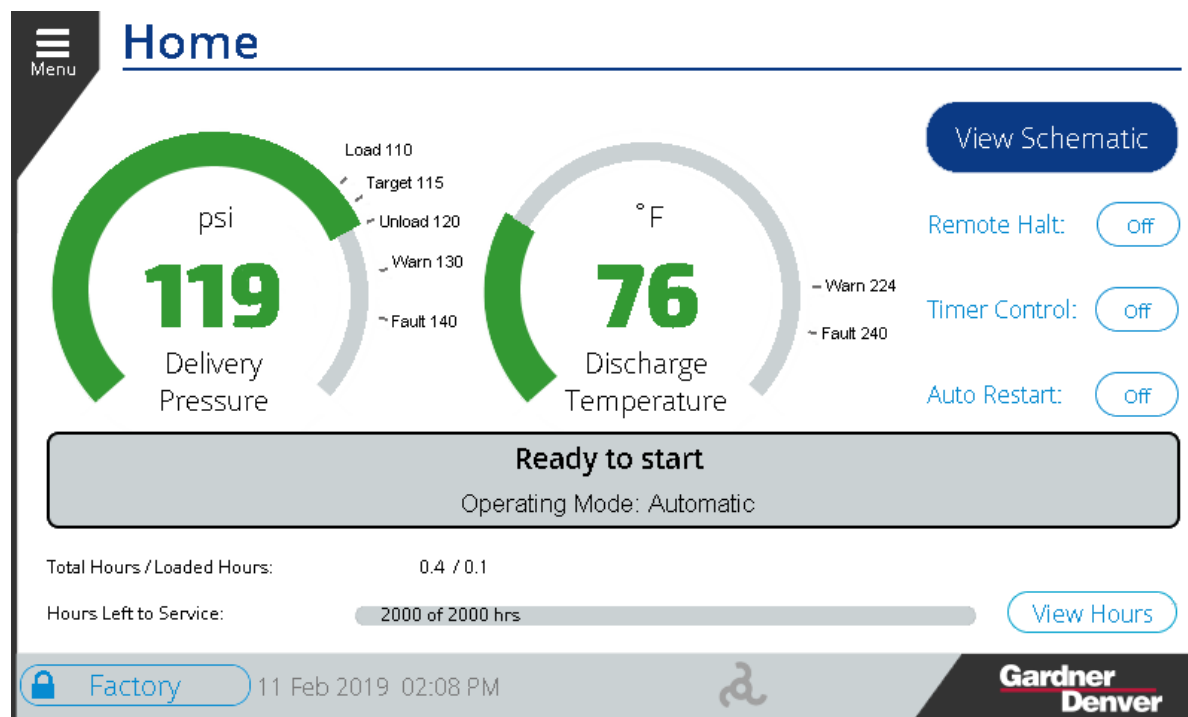



Figure 60: Home Screen Ready to Start

Press the **Start** button  on the display directly below the screen. If the delivery pressure is below the load pressure setting, the compressor will start and accelerate the motor, then open the inlet valve and begin building pressure. If this is the first time that the compressor has been started, make sure that all systems are working properly (refer to the machine service manual for more information).

3.9.2 Running

When running under the Automatic Operating Mode and control settings, compressor operation will continue as described below:

- The controller will attempt to keep the pressure within the set pressure band.
- If the machine is a variable speed system, the motor speed will be adjusted to attempt to keep the delivery pressure at the target pressure setting.
- If the delivery pressure exceeds the unload pressure setting, the controller will close the inlet valve and the Status Message Bar will display information about the new running state.
- If the pressure remains above the load pressure with the inlet valve closed for a set amount of time based on the machine design, the controller will stop the motor until the delivery pressure falls back below the Load pressure. While in this state, the Status Message Bar will indicate that the machine is enabled and will start when the pressure requirement is met as shown in Figure 61.

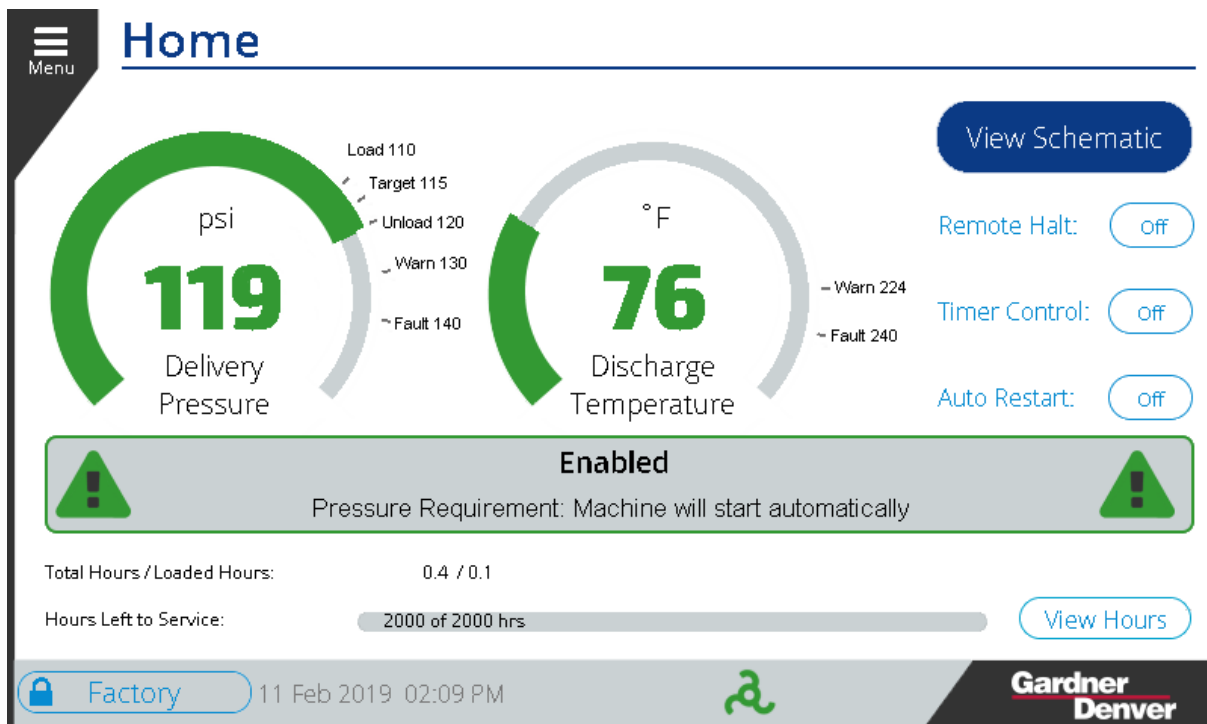



Figure 61: Home Screen Enabled

3.9.3 Stopping

To stop the machine, press the **Stop** button  directly below the screen. The machine will go through a soft stop process where it is depressurized before stopping. When the **Stop** button is pressed, the inlet valve will close immediately (if the machine is currently loaded) and the Message Status Bar will display that the controller is stopping as shown in Figure 62.

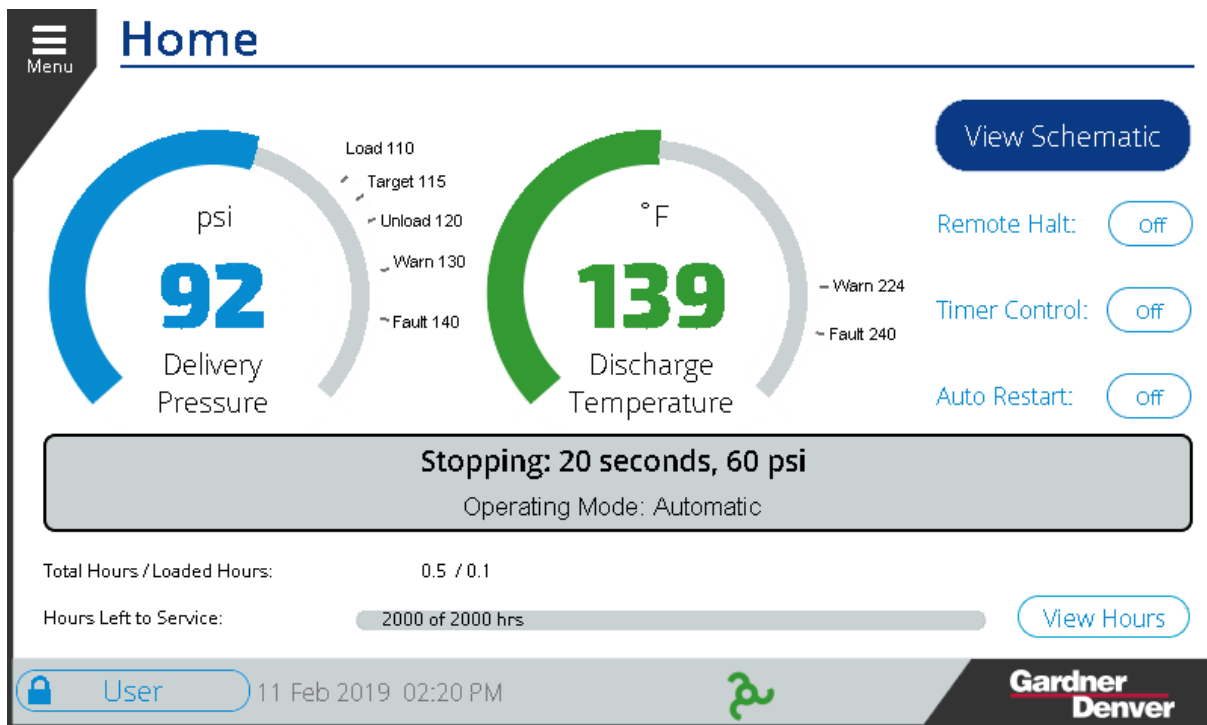

Figure 62: Home Screen Stopping

The progress of the stopping process is shown on the Message Status Bar. The time value shown (for example, “20 seconds”), is the time remaining on the minimum stop timer. The pressure value shown is the amount of pressure in the reservoir that must be vented for the system to be depressurized, or blown-down, to the appropriate value for the machine. For example, if the machine is designed to vent to 25 PSI in the reservoir and the reservoir currently has 85 PSI during the stopping process, the Message Status Bar would display 60 PSI. The motor will be stopped when both the time and pressure requirements have been met, or a maximum time of 120 seconds if the machine does not fully vent.

After stopping, the display will return to the Ready state.

3.9.4 Emergency Stop

The **Emergency Stop** button is located on the front door of the control panel close to the display and is identified by a red button with a yellow background. The **Emergency Stop** cuts power to outputs on the controller immediately and stops the machine abruptly. This should only be used in case of emergency where the machine must be stopped immediately.

Regular use of the Emergency Stop will cause damage to the machine. Always use the Stop button as described above to stop the machine under normal operation.

SECTION 4 SETTINGS

This section details each of the menus in the controller settings and the parameters that can be modified for the machine.

The **Settings** menu is sub-categorized into Service, Control, Configuration, Sequencing, Timer Control, Programmable I/O, and Advanced. Refer below to Table 29 for a quick link to each section.

Table 29: Settings

Settings	
Settings Menu	4.1 Service
	4.2 Control
	4.3 Configuration
	4.4 Sequencing
	4.5 Timer Control
	4.6 Programmable I/O
	4.7 Advanced

4.1 Service

The **Service** menu has two sub-menus labeled **Dashboard** and **Distributor Info**. Table 30 below summarizes the information that can be seen on these menus. This is an important menu for the service technician who will need to reset the status of certain machine elements that have a life expectancy and require changing after a certain number operating hours.

Table 30: Service Settings

Service Settings		
Setting	Sub-Menu / Section	Brief Information
Service	4.1.1 Dashboard	User can see and set the Air Filter Status, Oil Change Status, Oil Filter Status, Separator Change Status, Motor Lubrication Status, Oil Sample, Control Box Filter Status
	4.1.2 Distributor Info	Details related to Distributor Information such as Name, Phone, Website, and Email can be found here.

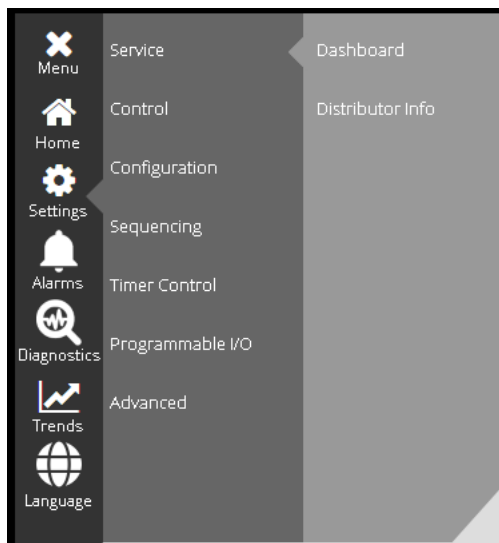

Figure 63: Service Menu

Figure 63 above shows the **Service** menu and its sub-menus: **Dashboard** and **Distributor Info**.

4.1.1 Dashboard

The **Service Dashboard** screen lists the *Hours/Days/Months* remaining for different machine elements that require changing after a specific time period. Figure 64 shows the **Service Dashboard**.

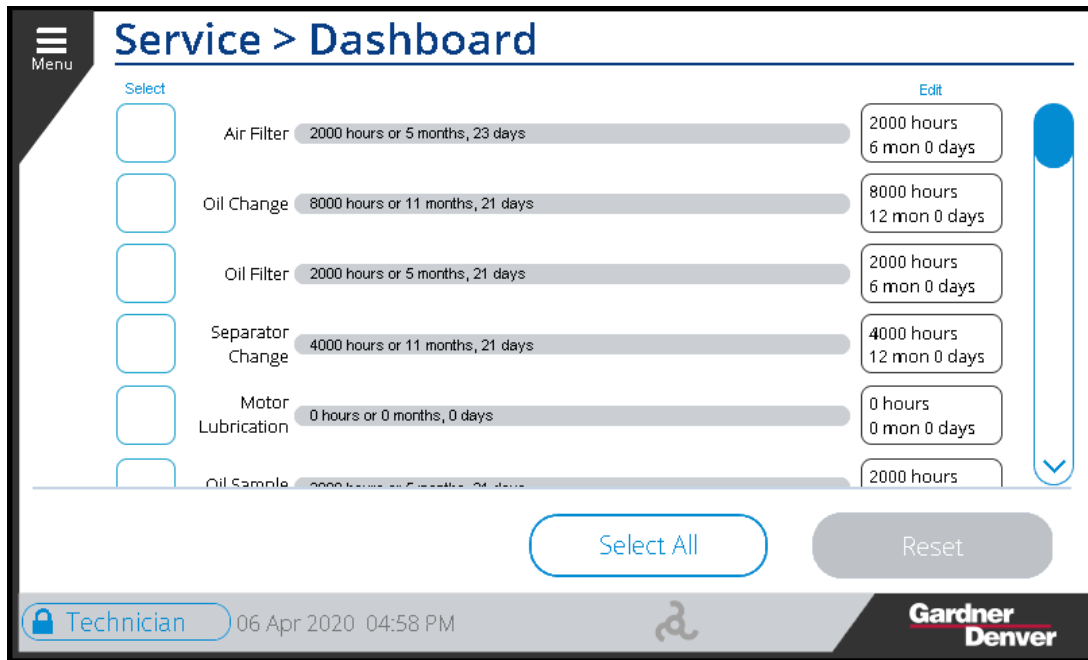

Figure 64: Service Dashboard

Each parameter has a gray bar that will change color based on the percentage of time remaining until a change is required for the specific element. The different colors that will be seen here are detailed below. Use the scroll up and down buttons to bring the desired parameter on screen to view, select, or edit it.

The *Air Filter* timer is shown below. The information shown on the bar is the time left for next service change of the air filter. As shown below, 2000 hours or 5 months, 23 days indicates left until the next service.



The color of the bar will adapt dynamically based on the time left to service each of the machine elements. See the below, for example, a new or full timer will appear as gray and transition to blue, yellow, and then red as the time expires.

- 100% service life, new timer or just reset:



- Service life greater than 350 hours:



- Service life of 350 hours or less:



- Service life of 175 hours or less:

- 1000 hours or 5 months, 23 days
- Service life greater than 15 days:
 - 2000 hours or 2 months, 20 days
- Service life between 14 days to 7 days:
 - 2000 hours or 0 months, 13 days
- Service life less than 7 days:
 - 2000 hours or 0 months, 5 days

Values of the parameters can be reset to default at any time. To change the value hit the box on the left side of the timer bar. Multiple parameters can be selected at a time. Once a box is checked the **Reset** option will be enabled at the bottom of the screen. Refer to Figure 65 below with *Air Flow*, *Oil Filter*, and *Separator Change* selected.

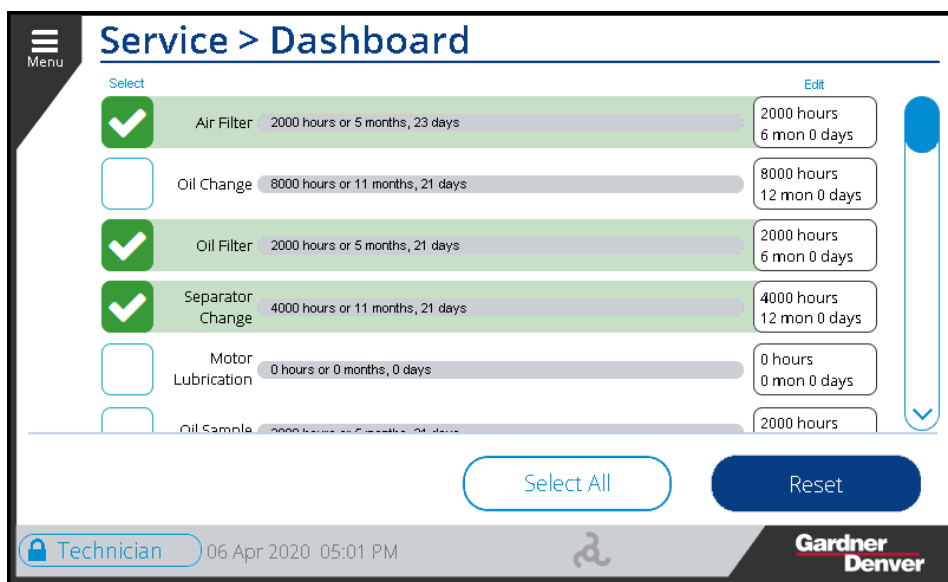

Figure 65: Select all option

Pressing the **Reset** button will bring up another screen as shown in Figure 66, confirming that system is resetting the time left to Service to its default values. Hit the **Close** button to return to **Dashboard** screen and see that the values have been reset.

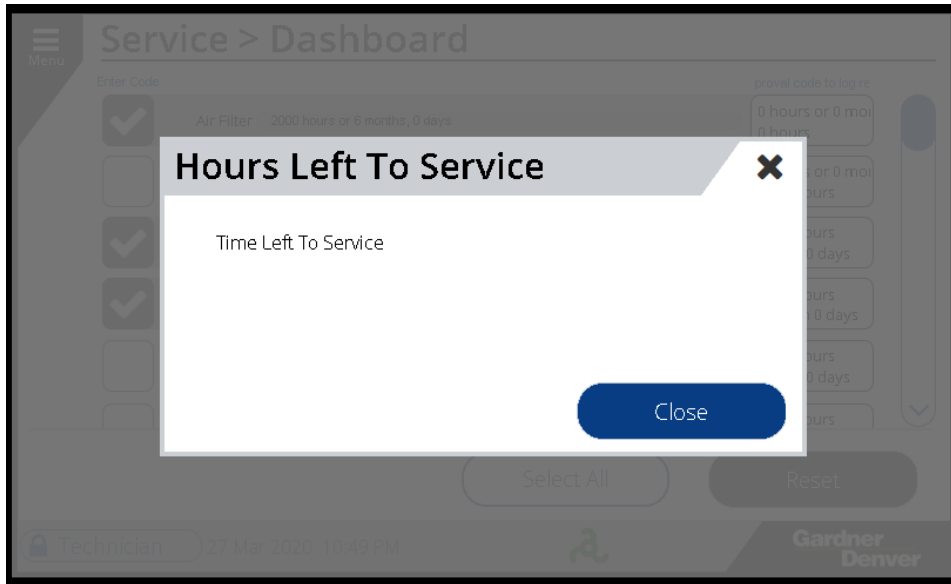

Figure 66: Hours Left to Service

To reset all the parameters use the **Select All** button to reset all parameters at the same time. Then hit the **Reset** button on the next screen.

4.1.1.1 Set Intervals:

While the bar graph shows how much time is left for the next service, the rectangular box on the right end of each bar is the service interval time setting. The *Air Filter* interval shown below, “2000 hours 6 Mon 0 Days”, is the time set for the service interval. This can be changed by selecting the box, the **Set Interval** screen will come up as shown in below Figure 67. The values for hours and calendar time may not exceed the factory default values for the machine. In certain circumstances it may be desirable to set the interval below the factory default. For example, in a very dusty environment it may be necessary to change the air filter at a shorter interval. Once the interval has been set, it will be used every time the maintenance timer is reset.

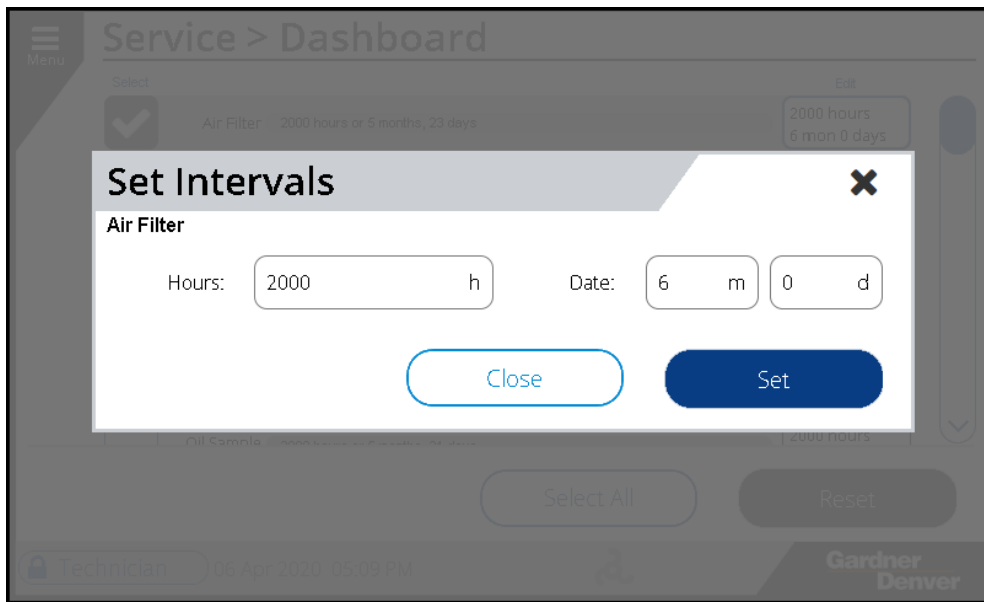

Figure 67: Set Intervals

To change the hours, touch the input box next to *Hours*. Similarly, *Date* can be set with the combination of month and days settings. Figure 68 below shows editing the hours for the *Air Filter*.

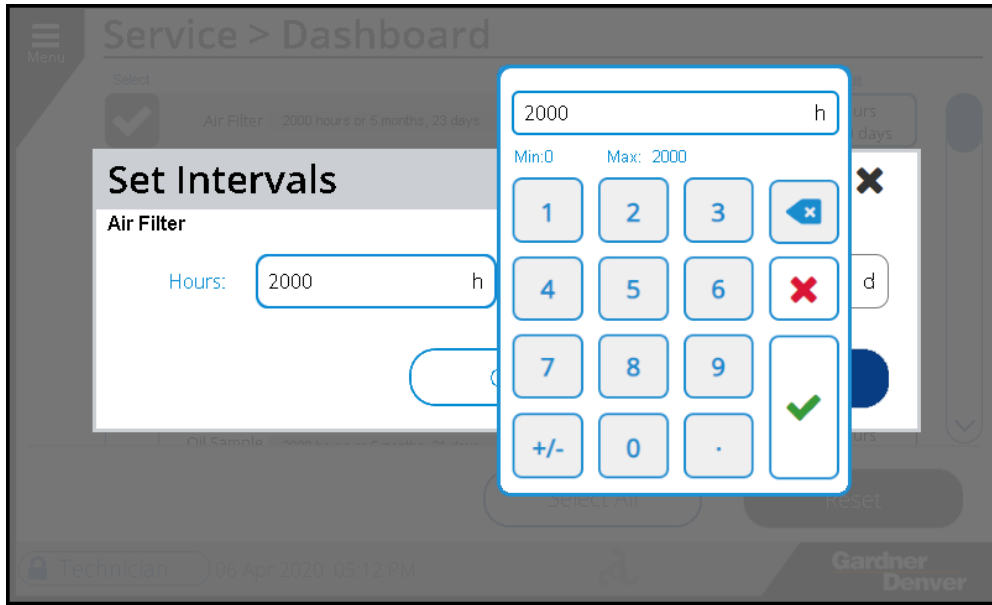

Figure 68: Set Intervals

All other service elements will be set or changed using the same logic as above.

4.1.1.2 Presetting a Timer Value

In some circumstances it is necessary to set the value of time remaining on a maintenance timer. For example, when replacing a controller in the field the timer values will need to be set to match the actual time remaining before they need to be changed.

To change the current value of a timer press anywhere on the bar which will bring up another screen called **New Service Times**, which displays the *Hours Left to Service* and *Time Left to Service*, shown in Figure 69 below. Only users with the technician or factory login credentials can create new service timers.

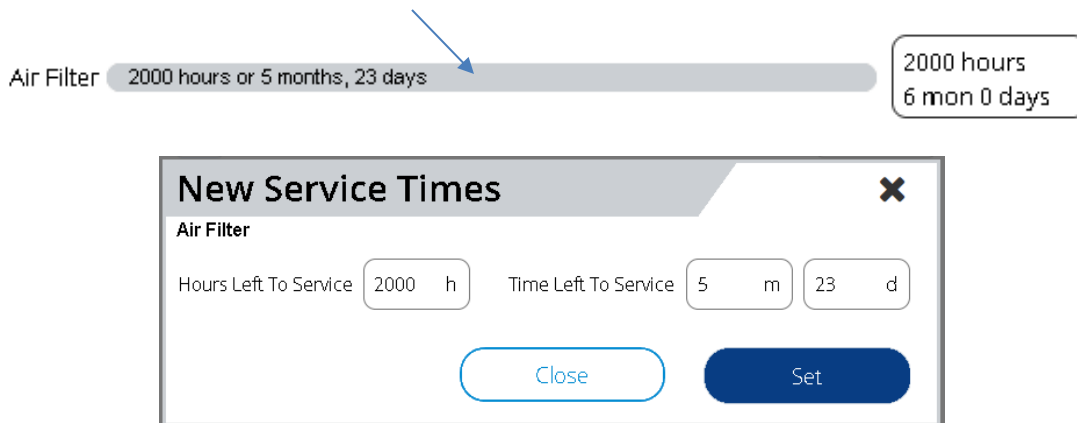

Figure 69: New Service Time

The service timers can be manually adjusted by selecting the input box and entering the new time on the number pad, shown in Figure 70, below. The time entered will need to be between the constraints shown as 'min' and 'max' on the number pad.



Figure 70: Hours Since Service

Once done hit the **Green Check**, followed by the **Set** button in next screen to confirm the new timer.

Note: confirming and saving values from the pop-up number pad and keyboard will be the same throughout this manual and will not be referenced again.

4.1.2 Distributor Info

The **Distributor Info** screen is shown below in Figure 71. It includes information such as the Distributor's Name, phone number, website, and Email address. This is the best starting point when needing a resource for information about the particular compressor.

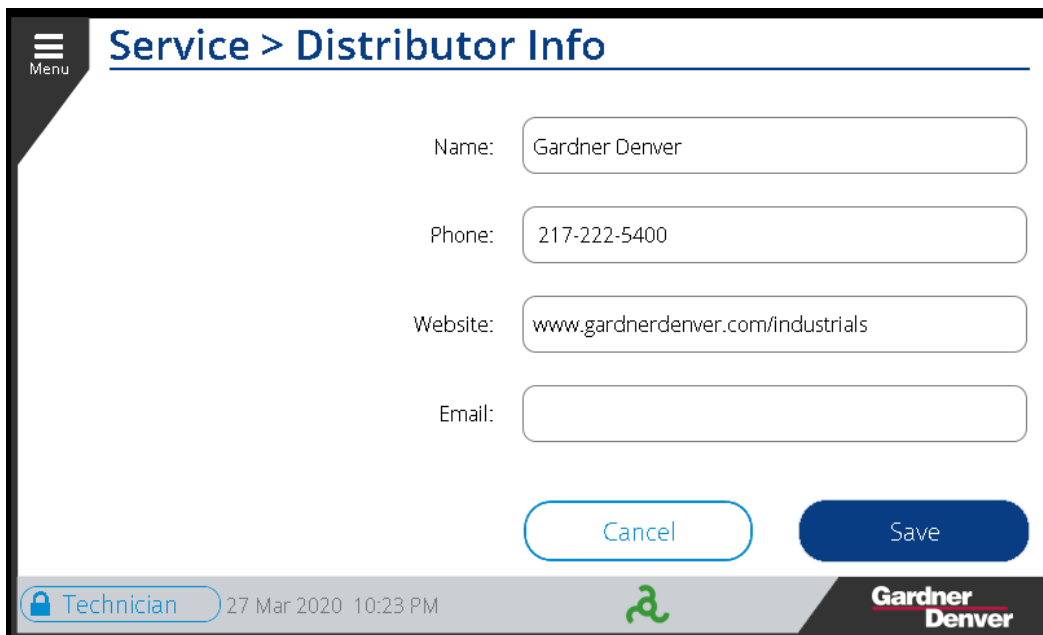

Figure 71: Distributor Info

Values for Distributor name, Phone, Website, and Email can be changed by touching the text box, which will bring up the key-pad to enter/edit the values, as shown below in Figure 72.

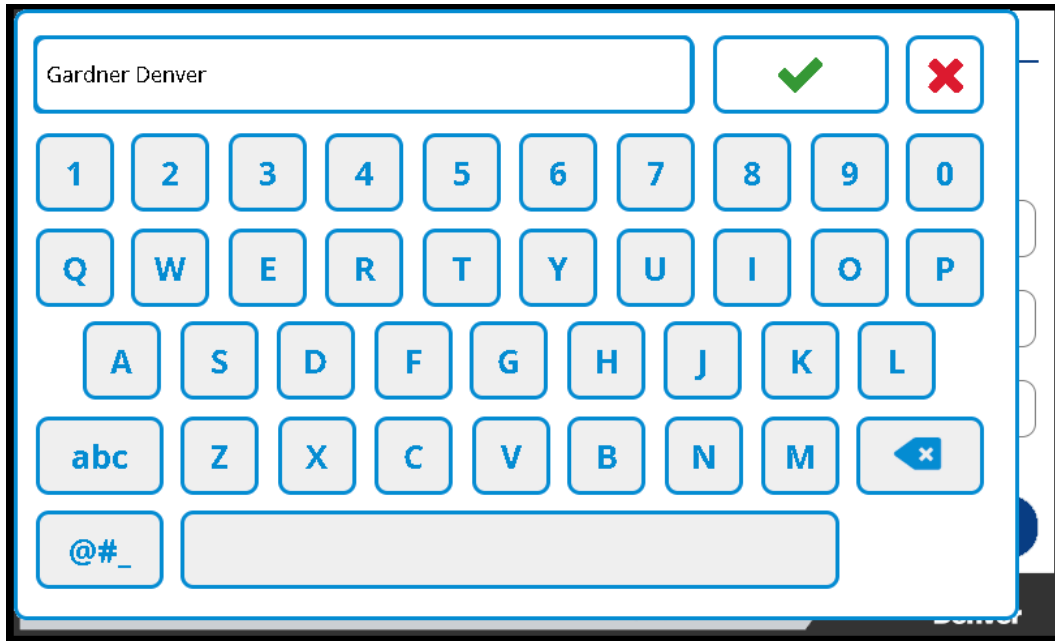

Figure 72: Distributor Info

4.2 Control

Table 31 below lists the settings available under the **Control** submenu of **Settings**.

Table 31: Control Setting

Control Settings		
Setting	Settings Available	Short Description
Control	4.2.1 Operating Mode	User can set and select the operating mode between Automatic, Sequencing, Constant, and Low Demand. This changes the way the controller runs the machine in order to provide air to the customers' system.
	4.2.2 p1 Pressure Band	Primary pressure band values can be set and edited here. The primary pressure band defines the default pressure set points of the compressor
	4.2.3 p2 Pressure Band	Secondary pressure band values can be set and edited here. The secondary pressure band defines alternative pressure set points that can be activated by a timer or control input.
	4.2.4 IV Control Mode	Change how the Inlet Valve is controlled. On machines that have inlet modulation this allows the mode to be set to load/unload or modulation.
	4.2.5 Remote Halt Mode	Remote Halt mode can be set between the available options of Timer, Immediate and Disabled.
	4.2.6 Timer Start Enable	Enable or disable starting and stopping the machine under timer control.
	4.2.7 Restart Delay Time	Restart Delay time sets the amount of time the controller will wait before restarting after a power failure.
	4.2.8 p2 Timer Enable	Enable or disable activating the secondary pressure band under timer control.
	4.2.9 Max Power Loss Time	Max Power Loss Time defines the maximum duration of a power failure event that can still allow a restart.
	4.2.11 Auto Restart Enable	Enable or disable automatic restart of the machine after a power failure.
	4.2.12 Dryer Pre-Run Time	Dryer pre-run time defines a timer that will be used to activate a dryer prior to starting the compressor.

Navigate to the **Control** menu by selecting **Settings** then **Control**. The **Control Settings** screen is shown in Figure 73 below.



Figure 73: Control Settings

Use the scroll bar at right to scroll through and select the different control parameters to change, edit, or save.

4.2.1 Operating Mode

The **Operating Mode** drop down menu will show the options available in that particular package configuration. In general there are four operating modes: *Automatic*, *Constant*, *Low Demand*, and *Sequencing*. Refer to Figure 74 below.



Figure 74: Operating Mode

By Default, *Automatic* mode will be set. However, it can be changed between the available options at any time. The available operating modes are described below.

Automatic Mode

This is the default operating mode, where the machine attempts to regulate in the most efficient manner possible. The capabilities of the machine and profile of the compressed air demand will be utilized by the controller in this operating mode. In periods of light demand the compressor motor will be automatically stopped to save energy.

Constant Mode

Constant Mode is best used in situations where there are no long periods of unloaded operation or for minimum response time to sudden demands. In constant mode the motor will be run continuously and the controller will use modulation controls to match delivery to demand. On machines that have the ability to run unloaded without depressurizing the reservoir, the reservoir will never be depressurized while the motor is running. On variable speed machines, the speed of the motor will be adjusted to regulate the pressure.

Low Demand Mode

The Low demand mode reduces power consumption by relieving pressure in the reservoir during unloaded operation. This mode is best used where there is moderate air storage and there are unloaded periods during the day, but frequent motor starting and stopping is undesirable. This mode is identical to constant mode during periods of moderate to high demand.

This mode of operation might not be available in all the machine configurations. It is available in systems where the compressor uses the two-valve load/unload solenoid system. This option cannot be selected when it is not available and will be grayed out. The Blowdown Timer is used, however, the Automatic Stop Timer is ignored in Low Demand mode.

Sequencing Mode

The Sequencing mode of operation is similar to Automatic Mode but the compressor is part of a sequenced group of machines. The controller controls the system with the combined data and operations of all the compressors that are part of the sequenced group of machines.

Refer to the *Governor sequencing manual (13-17-625)* for more information on operation in sequencing mode.

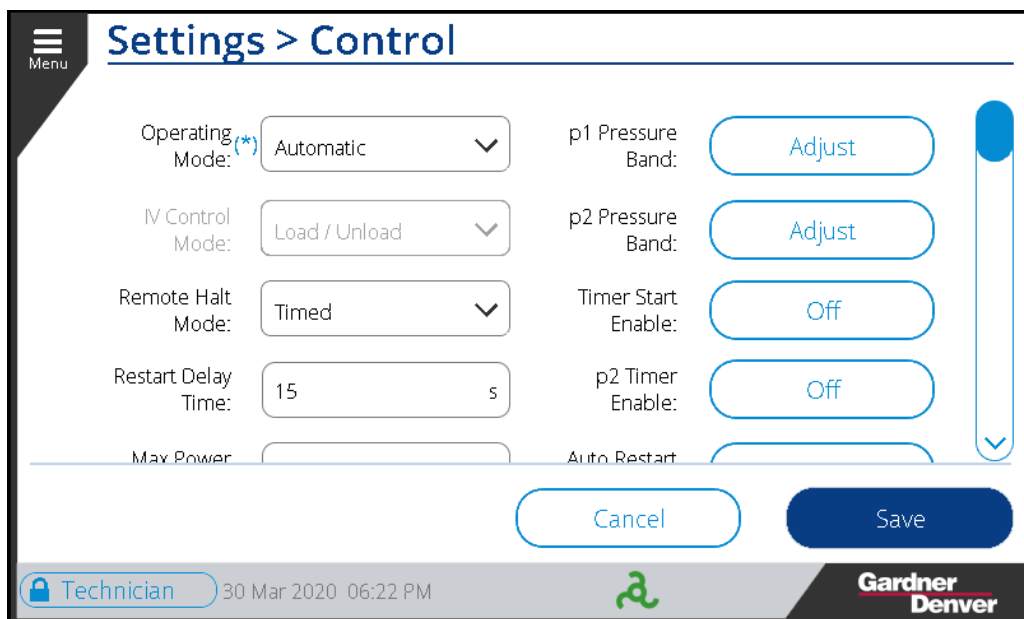

Figure 75: Operating Mode

4.2.2 p1 Pressure Band

There are two types of Pressure settings: *Primary (p1)* and *Secondary (p2)*, these allow to the user to configure two separate sets of pressure bands or curves that the compressor will operate within. The p1 value is the primary pressure band and defines the default pressure set points of the compressor while p2

is the secondary pressure band which defines alternative pressure set points that can be activated by a timer or control input. Both pressure band settings use the same type of interface and data entry, described below.

The **p1 Pressure Band** defines the default pressure set points of the compressor. The **p1 Pressure Band Settings** screen will look like Figure 76 below.

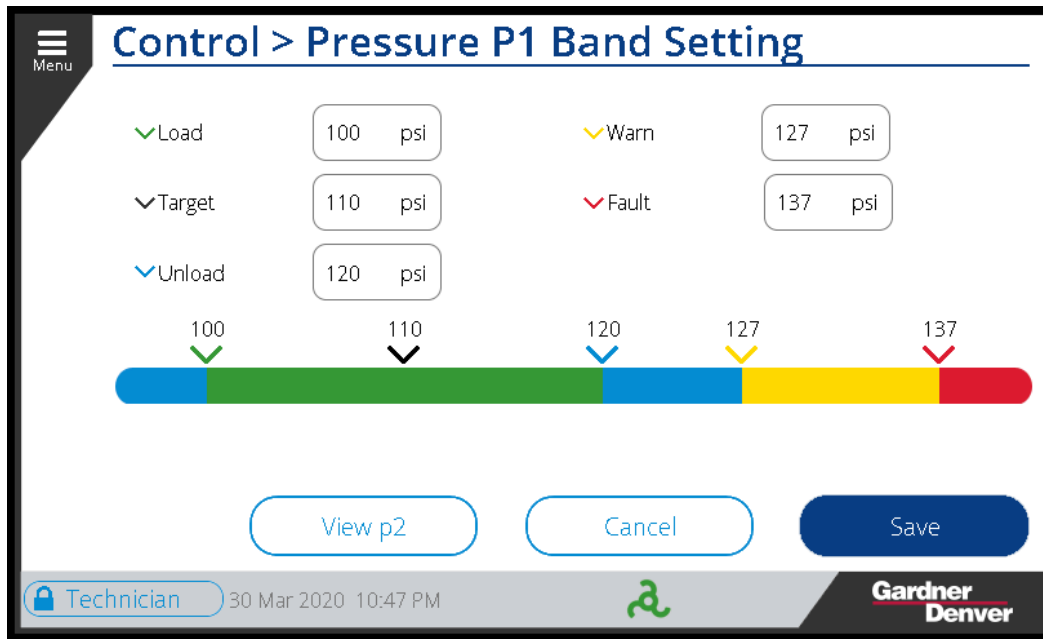

Figure 76: p1 Pressure Band

There are five parameters on the pressure band setting screen: *Load*, *Target*, *Unload*, *Warn*, and *Fault*.

Load pressure

This value is the pressure at which the compressor will open the inlet valve and begin producing air after an unload, blowdown, or stop sequence occurs. If the motor is not already running and the compressor has been enabled, the motor will be started when the pressure drops below the load pressure. This value must be set lower than the *Target Pressure* value.

Target pressure

This value is the pressure set point of the compressor. This is the pressure that the compressor attempts to maintain throughout daily operation. This is typically a value between the *load* and *unload pressure*. On variable speed machines the motor speed will be controlled to match this pressure set point. On machines with inlet and turn-valve modulation the machine will modulate to match this set point.

Unload pressure

This value is the pressure at which the compressor will close the inlet valve and begin the unload or blowdown sequence.

Warn pressure

This value is the pressure where the controller will flag a machine warning, meaning the pressure is reaching a critical level that is higher than the machine *unload pressure* value.

Fault pressure

This value is the pressure where the controller will flag a fault and shutdown the machine. This is a condition that will need to be taken care of immediately and reset at the controller HMI.

Any of the values can be set or changed by selecting the input box. A number keypad will come up for data entry. For example, *Target pressure* value entry screen will look like Figure 77 below.

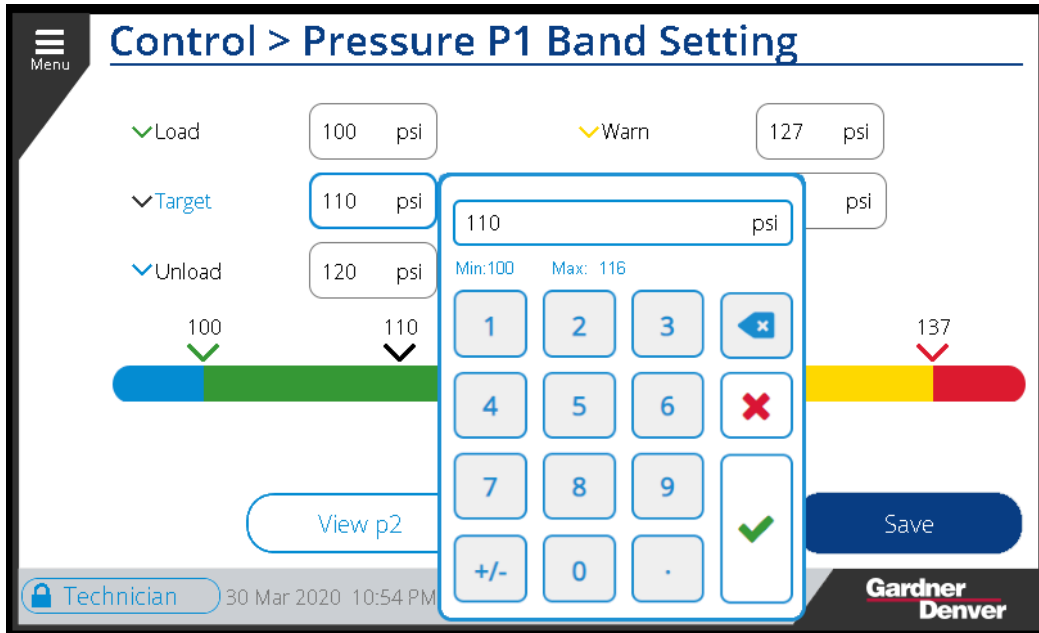

Figure 77: p1 Pressure Band

Note that there is a certain limit that can be set for each of the pressure values. For example, the *Target pressure* minimum is 100 psi which is the *Load Pressure Value*. If you want to set the *Target pressure* below 100 psi then the *Load pressure* needs to be changed first and it should be set lower than the *Target pressure*.

Similarly, the upper limit, max is 116 psi which is close to the *Unload pressure*. If you want the *Target pressure* greater than 116 psi then the *Unload pressure* needs to change first and its value should be greater than the desired *Load Pressure*.

The same methodology will be followed for setting the *Unload* and *Warn* pressure values.

We can toggle between the primary pressure and secondary pressure screen with the button available on the bottom of the **Pressure Band Setting** screen. The **p1 Pressure Band** screen has a button called **View p2** to jump to **p2 pressure band** screen.

4.2.3 p2 Pressure Band

The **p2 Pressure Band** defines alternative pressure set points that can be activated by a timer or control input. This band can be used for when the compressor is operating at off-hours or during the weekend when production is not functioning at full output and therefore does not have the same pressure requirements.

Similar to the primary pressure band settings, it has five parameters: *Load*, *Target*, *Unload*, *Warn*, and *Fault*. Any of these values can be changed by selecting the input boxes. A sample screen of **p2** is shown in Figure 78 below. The warning and fault setting on the **p2** screen is the same set point as the set points on the **p1 pressure band** settings screen.

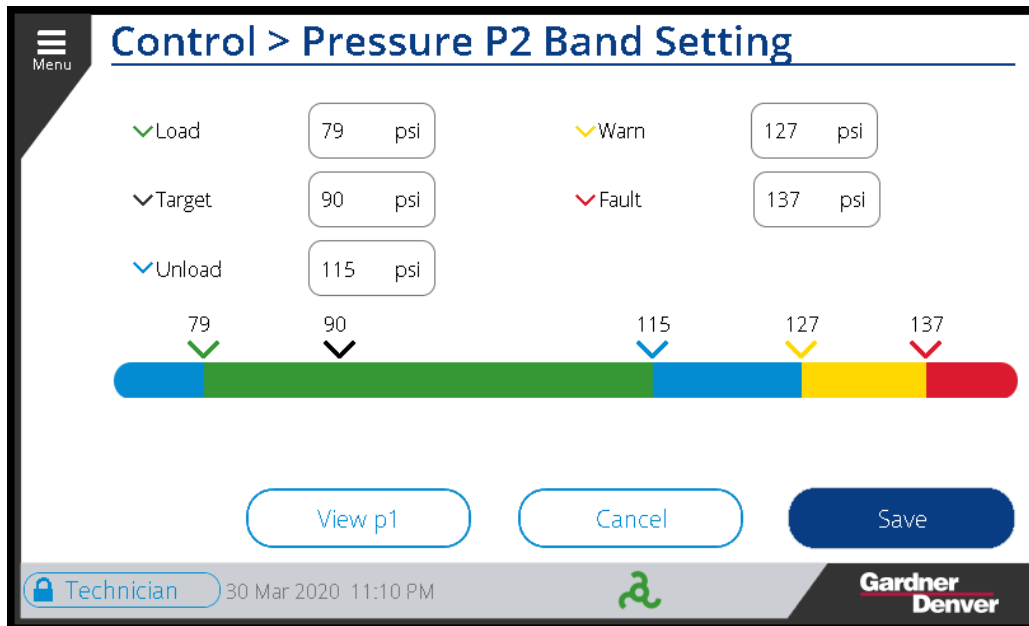

Figure 78: p2 Pressure Band

The user can switch to the *Primary Pressure Band* screen by hitting the **View p1** button available on the screen.

4.2.4 IV Control Mode

These settings are only available on machines that have inlet valve modulation capability. The way the inlet valve is controlled can be changed here between *load/unload* and *modulation*.

Inlet Valve Control Mode allows the user to change the operation of the inlet valve on the compressor to either *Load/Unload* or *Modulation*. When set to *load / unload*, the inlet valve will open at the load set point and close at the unload set point, but will not modulate to the target pressure set point. While in *modulation* mode, the compressor will attempt to modulate the inlet valve and maintain the target pressure set point.

4.2.5 Remote Halt Mode

There are three options for **Remote Halt Mode** operation. The modes are *Timed*, *Immediate*, and *Disabled*. These can be selected from the dropdown menu shown in Figure 79 below.

The **Remote Halt Mode** controls how the compressor will stop if a remote halt signal is detected on a programmed digital input on the controller IO module. Refer to the compressor's electrical wiring diagram for connection of an external remote halt signal.



Figure 79: Remote Halt Mode

Timed mode means the compressor will stop after the unload, blowdown, and automatic stop timers have expired upon receiving a remote halt signal. The compressor will act as if the pressure exceeded the unload set point. If the remote halt signal is removed at any point the compressor will re-load, as long as the pressure is not above the unload pressure set point.

Immediate mode means the compressor will unload, blowdown, and stop immediately upon receiving a remote halt signal. This stopping process is essentially the same as if the stop button has been pressed on the controller.

Disabled mode is used when there are no remote halt signals programmed to a digital input or when this function needs to be switched off for any reason. Control will continue locally at the machine controller in this mode.

4.2.6 Timer Start Enable

Timer Start Enable allows the user to *enable* or *disable* the starting and stopping of the machine under timer control. If currently shown as *Off* then pressing it again will toggle it to *On* and Vice-Versa. Refer Figure 80 below.

When the **Timer Start Enable** is turned on the compressor will start and stop based on the schedule set under the timer control settings page. If this is disabled then the compressor will continue to run as normal regardless of the schedule.

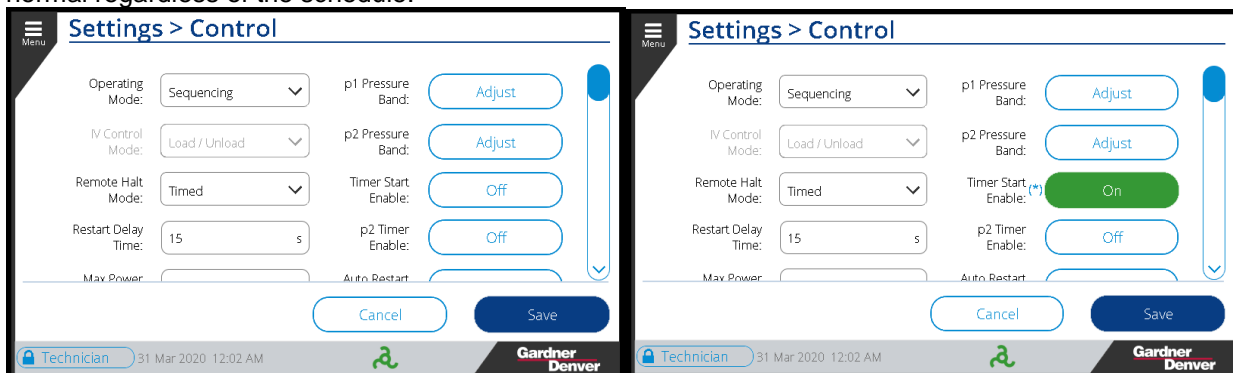

Figure 80: Timer Start Enable

4.2.7 Restart Delay Time

The **Restart Delay Time** sets the amount of time the controller will wait before restarting operation after a power failure has occurred. The user can input the desired value on the number pad. Refer to Figure 81 below.

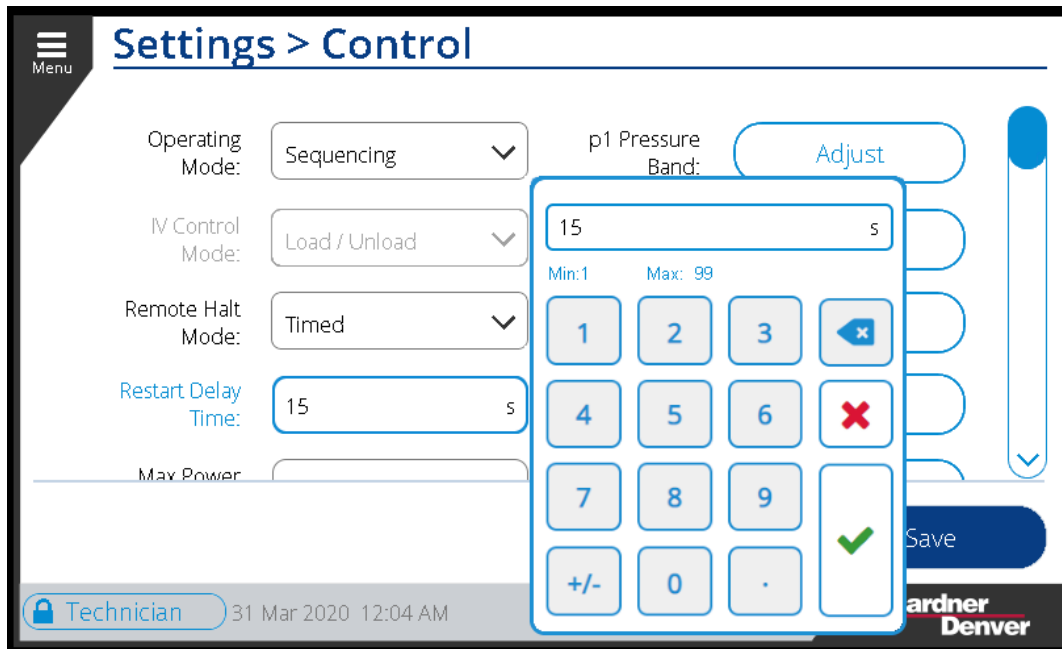

Figure 81: Restart Delay Time

4.2.8 p2 Timer Enable

The **p2 Timer Enable** setting allows the user to *enable* or *disable* the activation of the secondary pressure band based on the timer control. The schedule for this timer is set under the **Timer Control Settings** page. When **p2 Timer Enable** is set to on the pressure set point will be automatically adjusted based on the schedule. Refer to Figure 82 below.

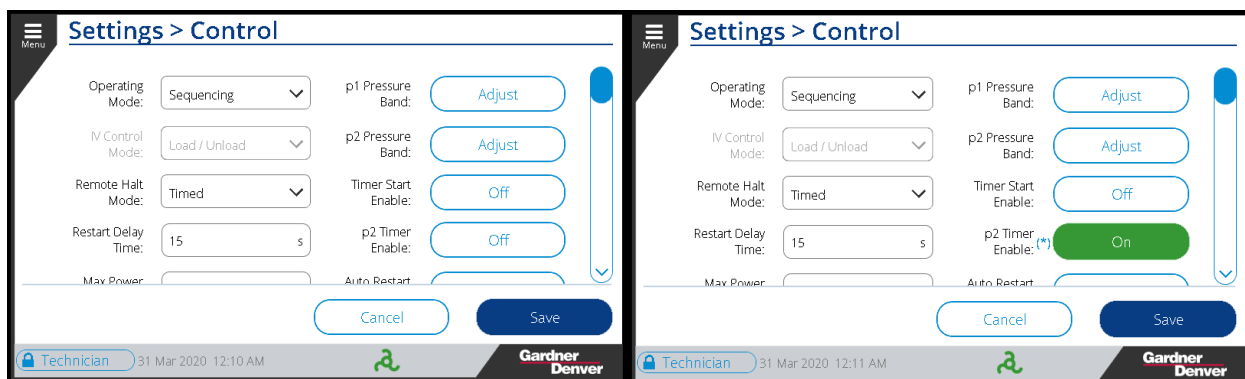

Figure 82: p2 Timer Enable

4.2.9 Max Power Loss Time

The **Max Power Loss** defines the maximum duration of a power failure event that will still allow a restart of the machine. Values can be set between 1 and 999 seconds. Refer to Figure 83 below for **Max Power Loss** time entry screen. If the power failure occurs and continues for longer than the values set in the max power loss time setting the controller will not allow the machine to restart and a power loss fault will be registered.

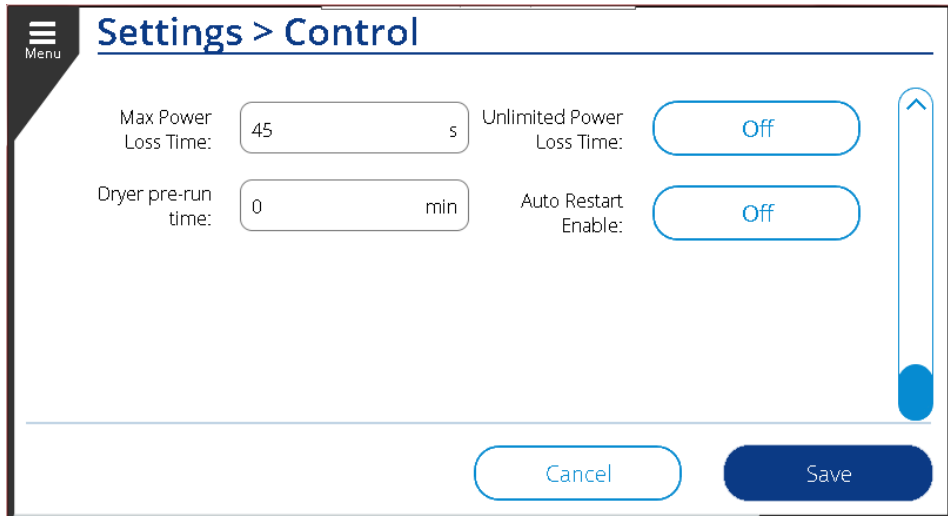

Figure 83: Max Power Loss Time

4.2.10 Unlimited Power Loss Time

When the **Unlimited Power Loss Time** is turned *On* the **Max Power Loss Time** setting will be disabled and the controller will allow the machine to restart regardless of the duration of the power failure.

4.2.11 Auto Restart Enable

Auto Restart Enable can be toggled *on* or *off* by pressing the button show below in Figure 84. When *auto restart* is enabled and a power failure occurs, the controller will automatically return the machine to the operating state it was in prior to the power failure. With this setting off the machine will need to be started again manually. A power failure event will cause a warning to be entered in the alarm history when auto restart is enabled but it will not be treated as a fault.

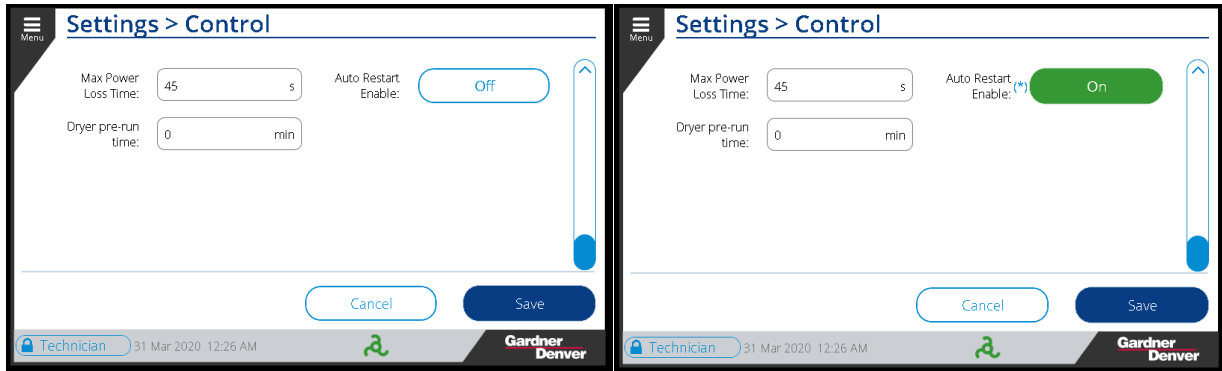

Figure 84: Auto Restart Enable

4.2.12 Dryer Pre-Run Time

The **Dryer Pre-Run Time** is the time, in minutes, the machine dryer or external dryer should run to reach its optimal operating temperature before the compressor motor will be allowed to start. The **Dryer Pre-Run Time** can be set by selecting the input box and entering the time on the keypad window. Refer below Figure 85 for reference.

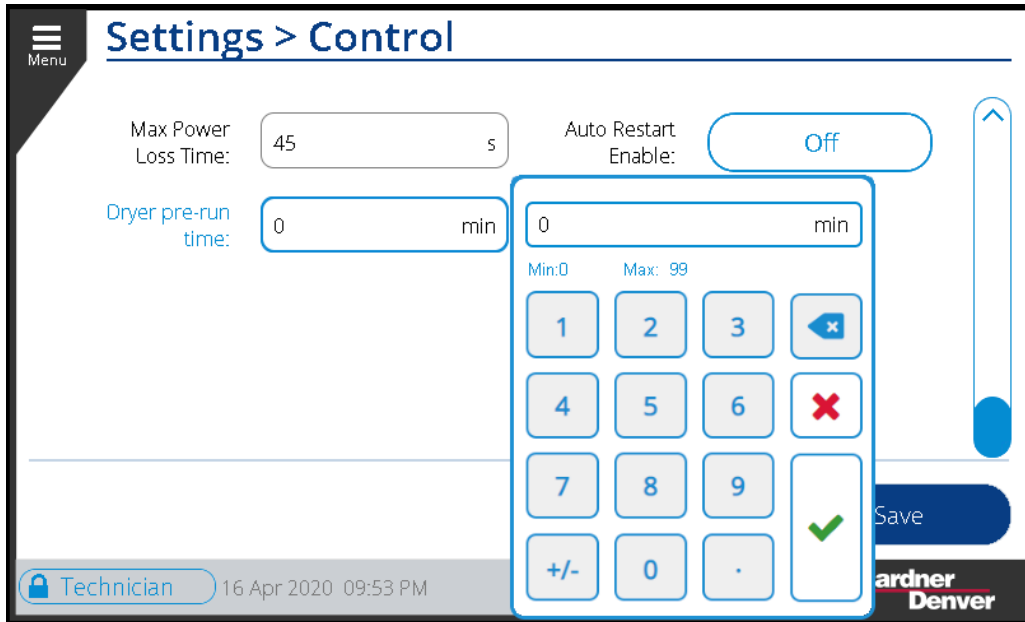

Figure 85: Dryer Pre-Run Time

When the compressor is started by local or remote control, it will activate the dryer start programmable output and then wait for the duration of the **Dryer Pre-Run Time** before starting the compressor motor.

4.3 Configuration

Table 32 below gives a brief overview of the available configuration settings. Figure 86 shows the **Configuration** menu selection on the controller. This section of the controller contains settings that are not related to the control of the machine.

Table 32: Configuration Setting

Configuration Settings		
Setting	Sub-Menu	Short Description
Configuration	4.3.1 Locale	The User can see and set the Pressure Units, Temperature Units, Flow Units, and Language under this section
	4.3.2 Date & Time	The User can set the time, date, and time zone.
	4.3.3 Communication	The User can set or edit the following parameters: Ethernet Configuration Mode, IP Address, Subnet Mask, and Gateway Address. The RS485 settings can also be configured here.
	4.3.4 Security	This screen allows changing and resetting passwords.
	4.3.5 Advanced	The User can set and select the logging level and temporarily disable the Firewall.

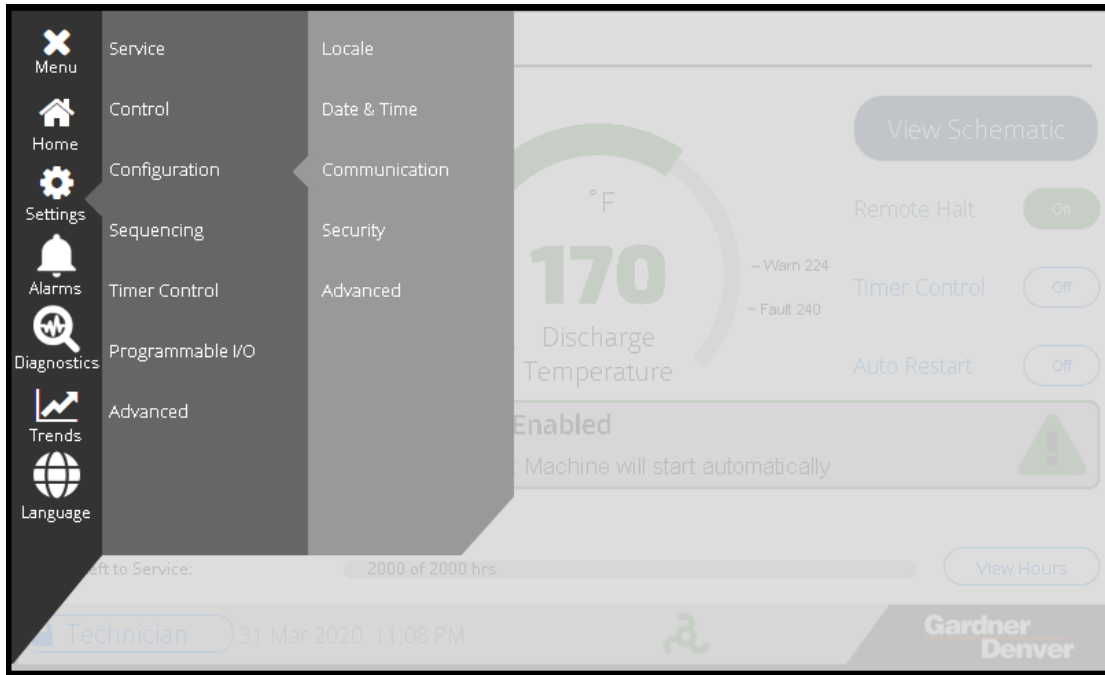

Figure 86: Configuration Menu Selection

4.3.1 Locale

Under the **Locale** configuration menu the user can select the units used for different machine data such as the *pressure*, *temperature*, and *flow*.

Pressure Units:

With the drop down menu, the user can select the pressure units between *bar* and *psi*, as shown in Figure 87 below.

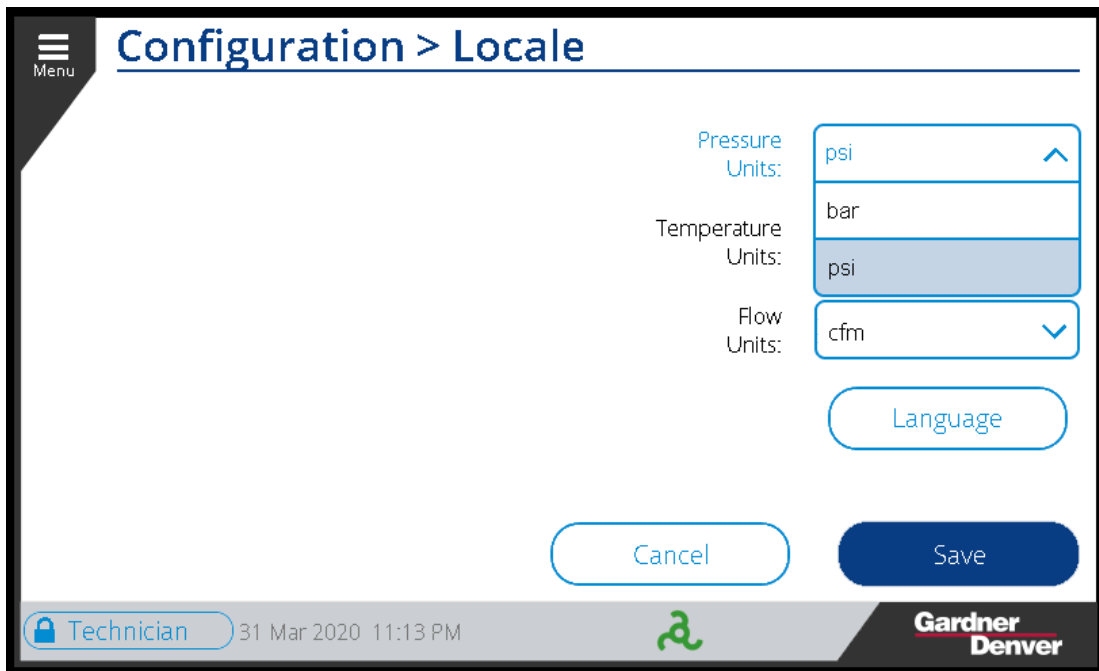

Figure 87: Pressure Units

Temperature Units:

The User can set the temperature units to either °C or °F as shown in Figure 88 below.

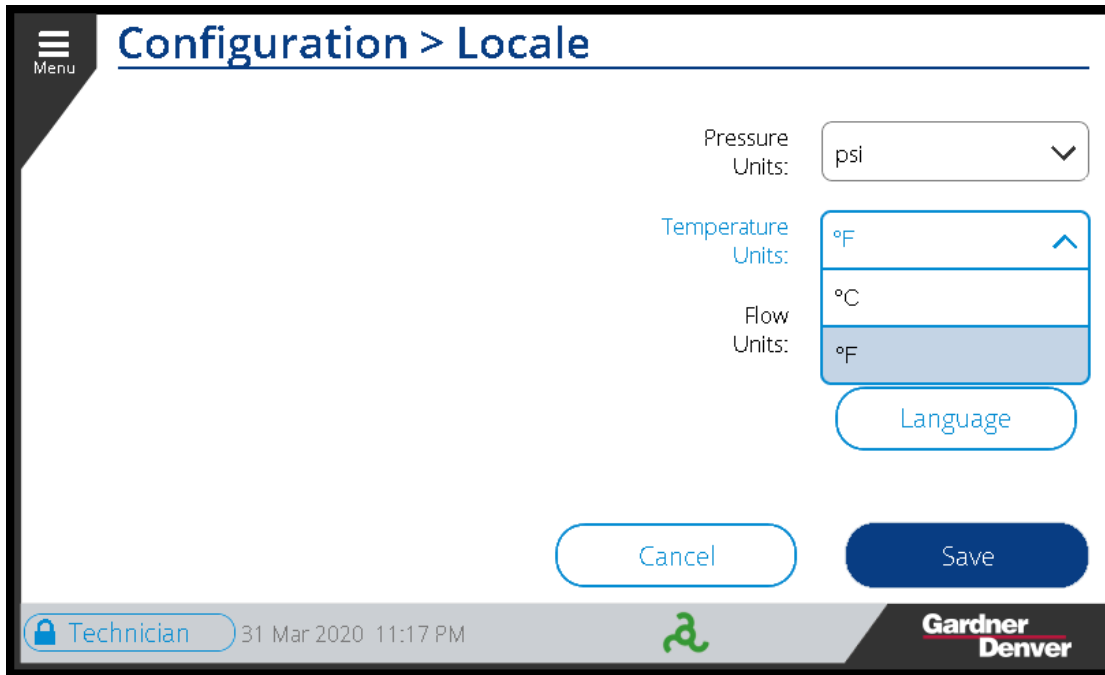

Figure 88: Temperature Units

Flow Units:

The User can set the flow units between m^3/min , m^3/hr , and cfm as shown in Figure 89 below.

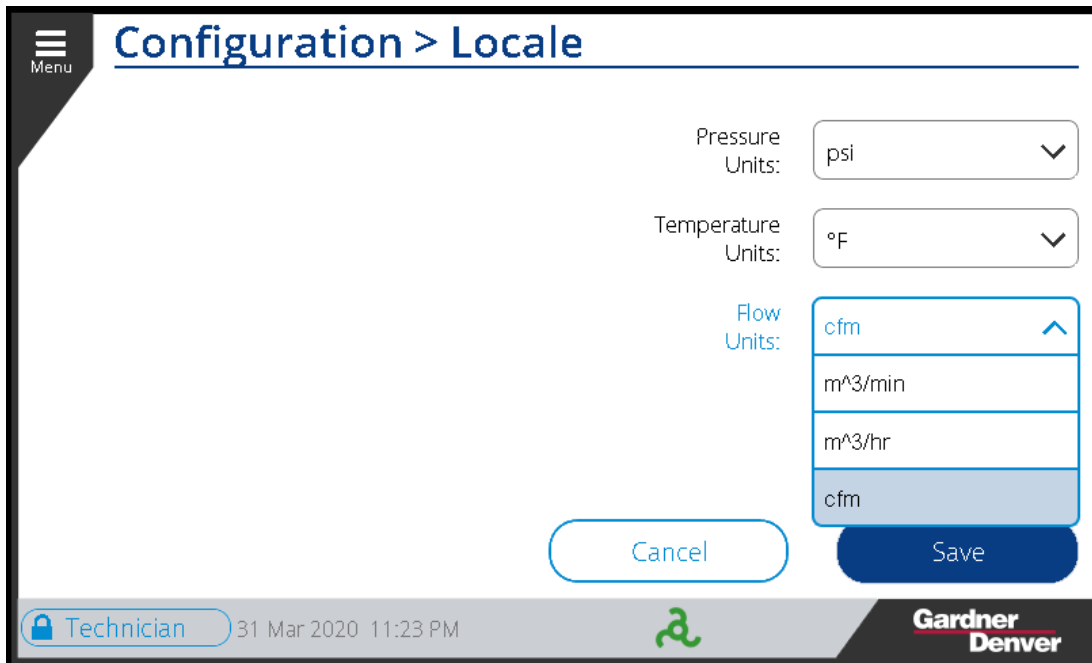

Figure 89: Flow Units

4.3.2 Date & Time

This screen has seven parameters which can be edited with the pop-up keypad/dropdown menu. These **Date** and **Time** parameters are: *Year*, *Month*, *Day*, *Hour*, *Minute*, and *Second* values as well as the *Time zone*. Figure 90 shows the **Date & Time** configuration settings screen. Note, the *Timezone* should be set before editing the other **Date & Time** settings.

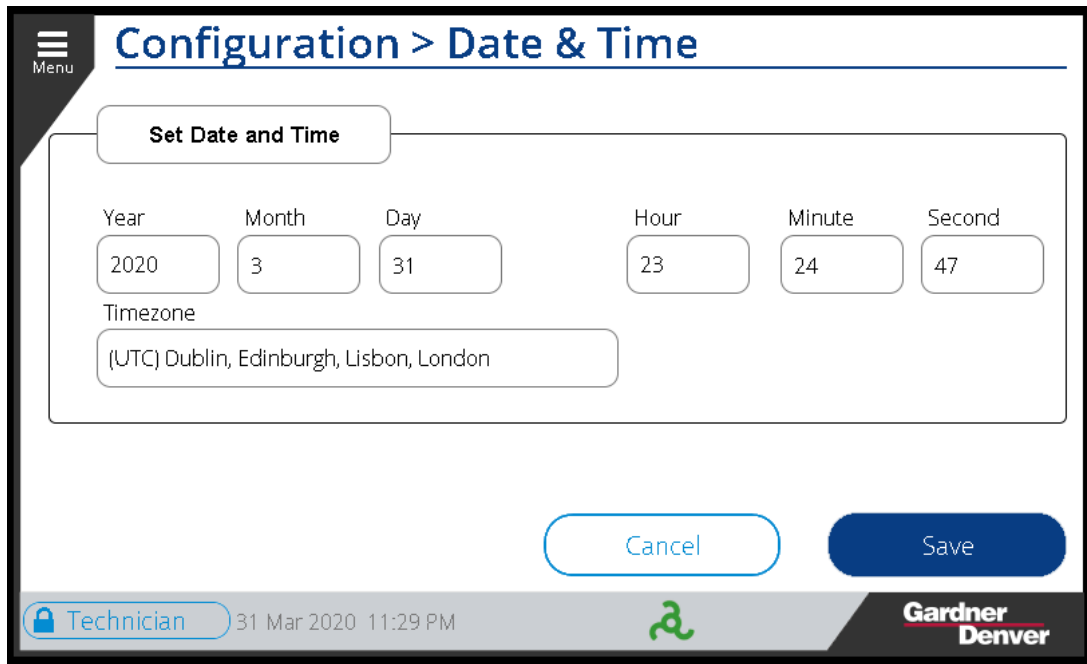

Figure 90: Date & Time

Each parameter has a min and max value that may be entered. *Year* can be selected from 2018 to 2106, *Month* can be entered between 1 to 12, *Day* between 1 to 31, *Hour* between 0 to 23, *Minute* between 0 to 59 and *second* between 0 to 59. Figure 91 below shows an example for setting the hours on the keypad. When the **Timezone** is set correctly, the controller will automatically adjust the time for adjustments such as daylight savings time.

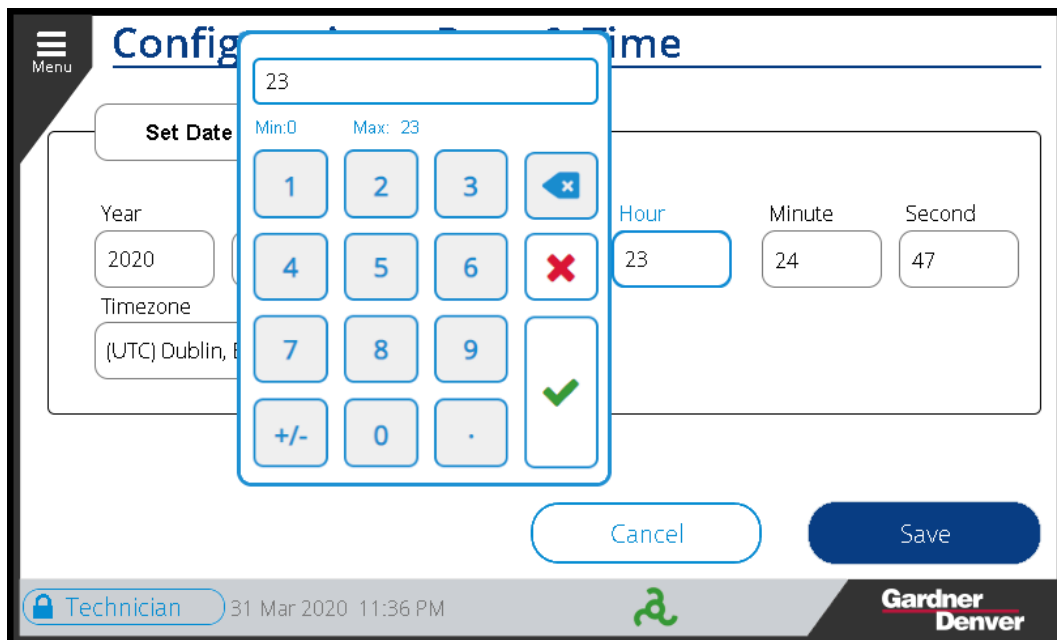

Figure 91: Hours Settings

4.3.3 Communication

There are three communication protocol sub-menus available on the **Communication** screen: *Ethernet*, *RS485 0*, and *RS485 1*.

Note, certain machine configurations will show an additional RS485 port labeled *RS485 2*, which will have identical settings to the *RS485 1* port.

Ethernet:

Under **Ethernet** settings, the following parameters can be set: **Ethernet Configuration Mode** between *Static* and *DHCP* from drop down menu, **IP Address** with number pad entry, **Subnet Mask** with number pad entry, and **Gateway Address** with number pad entry. Figure 92 below shows the **Ethernet** tab settings. Note that if the controller is set to DHCP it will automatically attempt to retrieve IP network settings from a local DHCP server. In this case you will not be able to set the other values and the IP addresses that are acquired will be shown in the respective fields.

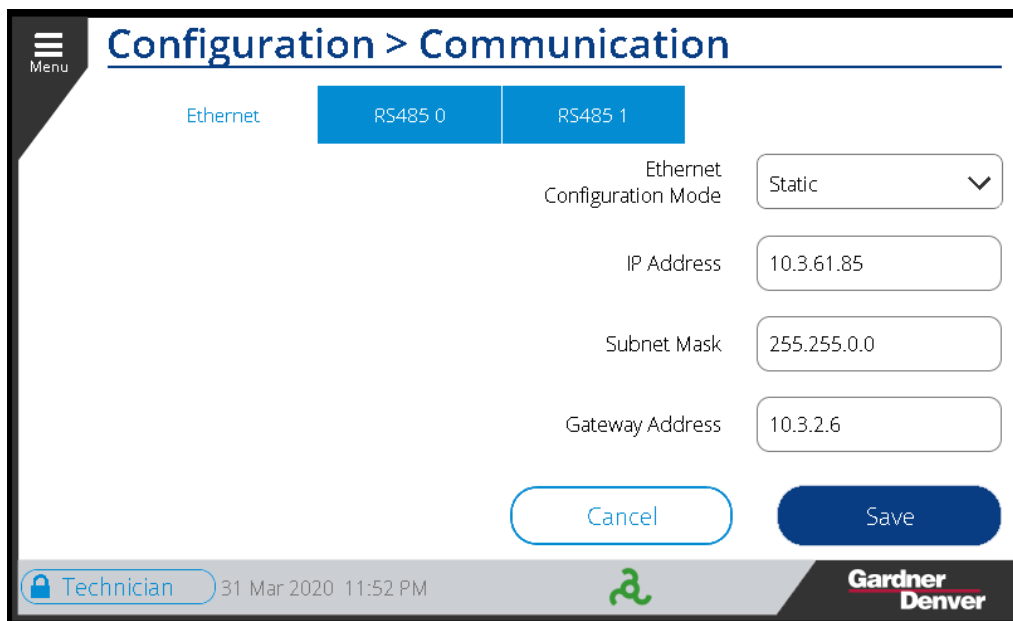

Figure 92: Ethernet

RS485 0:

Communication Mode can be selected between *Disabled*, *Sequence – AirSmart*, *Sequence – Delcos*, *Sequence – ES+*, *Modbus Master*, and *Modbus Slave* from drop down menu. Figure 93 below shows the mode selection drop-down menu options.

Table 33: Communication Modes

Communication Modes	
Mode	Function Description
Disabled	The communication mode for this port is disabled and not functional
Sequence – AirSmart	AirSmart Protocol can sequence up to 8 variable speed or fixed speed compressors or a mix of the two. This protocol is designed to handle sequencing and load sharing for direct and optimal control
Sequence – Delcos	Delcos Protocol can sequence up to 4 compressors, one compressor must be configured as the master with up to 3 slaves connected. All slave machines run off the master machine's delivery pressure sensor.

Sequence – ES+	ES+ Protocol is designed to optimize systems of machine with turn valve or inlet valve modulation. The system will automatically rotate the lead of the system and vary modulation across all of the machines to save energy.
Modbus Master	The machine will be assigned as a Master in the sequence.
Modbus Slave	The machine will be assigned as a Slave in the sequence.

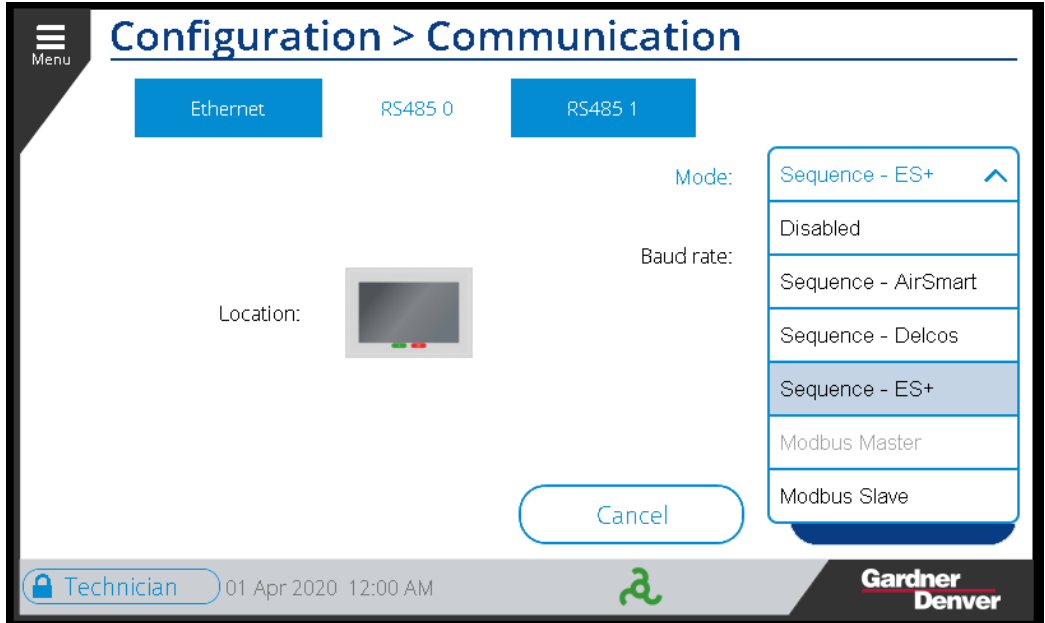

Figure 93: RS485 0 Mode

Baud Rate:

This is the bit rate the system will be using for data transfer. The available options in the drop down menu are: 1200, 9600, 19200, 38400, 57600, and 115200. Figure 94: RS485 0 Baud Rate shows the **Baud Rate** selection drop down menu option. Note only the baud rates compatible with the mode currently selected will be available.

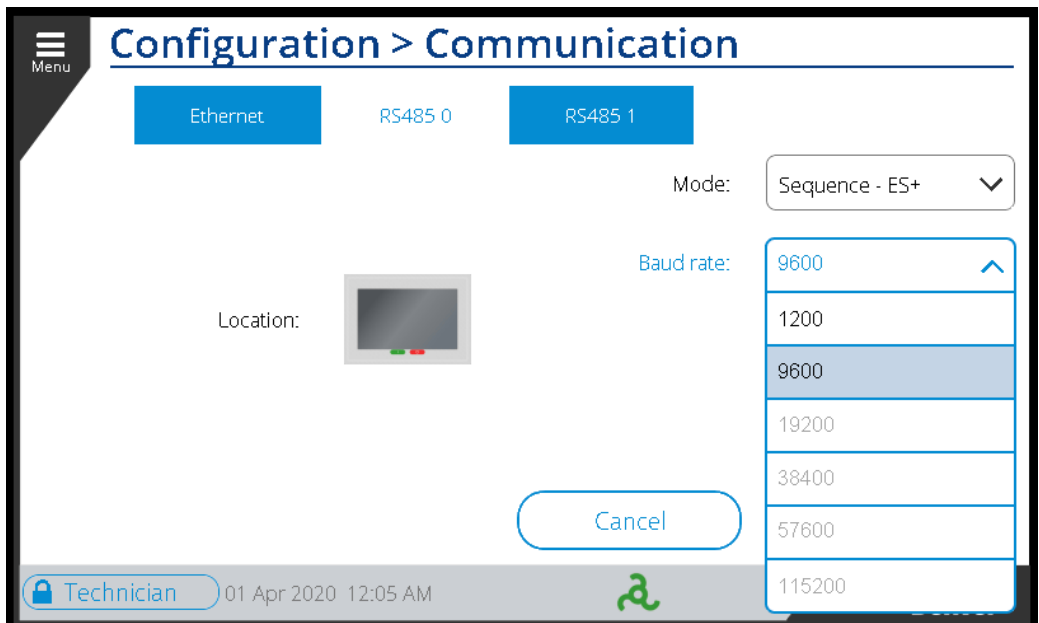

Figure 94: RS485 0 Baud Rate

Node ID:

The **Node ID** is the Modbus address of the device when set to Modbus slave.

Byte Swap:

Byte Swap changes the order of bytes or endianness of the data in a 16-bit Modbus register.

RS485 1:

RS485-1 has the same type of settings and screens as **RS485-0**. The location of each of these communication ports are shown in the middle of the screen when selecting the various tabs at the top. Refer to Table 33 above for a description of each mode that can be selected.

4.3.4 Security

In the **Security** settings the password can be managed or changed for a specific user level. Note that a *User* level login won't see this option. This is available when there is *Maintenance*, *Technician*, or *Factory* login and only *Technician* and *Maintenance* login password change is allowed. Figure 95 below is the **Security** screen. The password for the current level user and any lower level user may be changed. For example, Maintenance may only change a maintenance level password, technician may only change technician and maintenance level passwords. The factory password may not be changed.

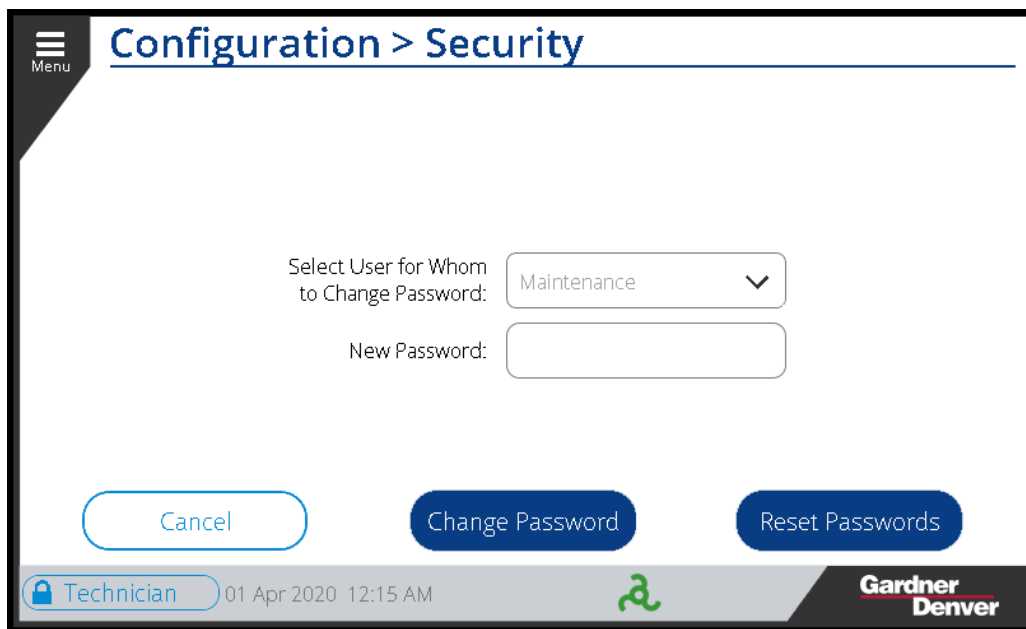

The screenshot shows a web interface titled "Configuration > Security". In the top left corner, there is a "Menu" icon. The main content area contains a form with the following elements:

- A label "Select User for Whom to Change Password:" followed by a dropdown menu currently showing "Maintenance".
- A label "New Password:" followed by an empty text input field.
- Three buttons at the bottom: "Cancel" (light blue), "Change Password" (dark blue), and "Reset Passwords" (dark blue).

The bottom of the screen features a status bar with a lock icon, the text "Technician", the date and time "01 Apr 2020 12:15 AM", a green logo, and the "Gardner Denver" logo.

Figure 95: Security Configuration Menu

To change the password, click the box next to *New Password* and a number pad will come up. Enter desired password to set. Figure 96 below shows the number pad.

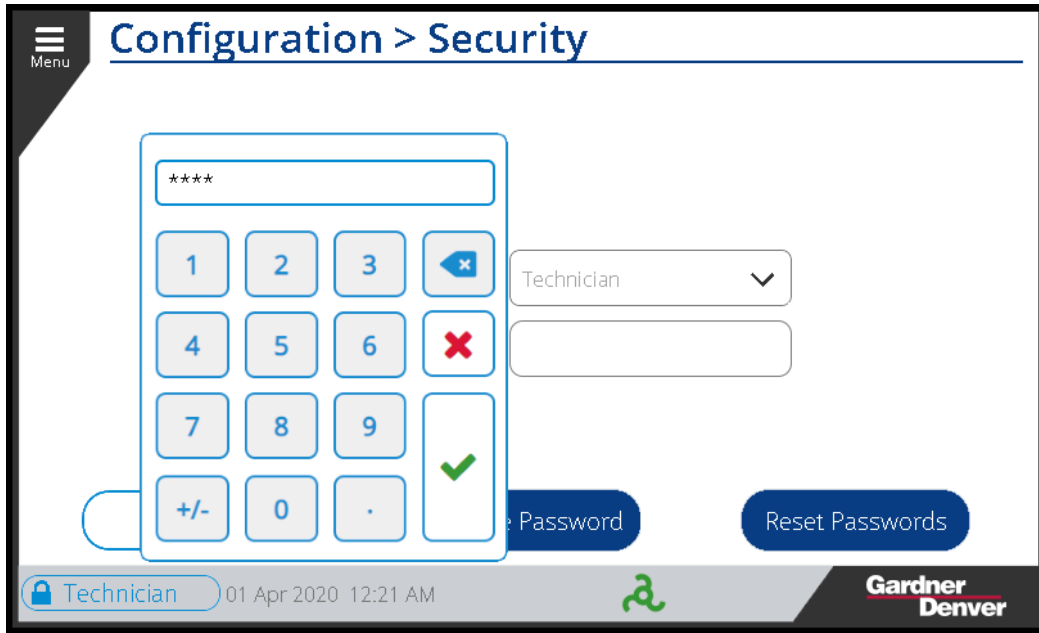

Figure 96: New Password

Once done hit the **Change Password** button and another screen will come up confirming the password has changed as is shown in Figure 97.

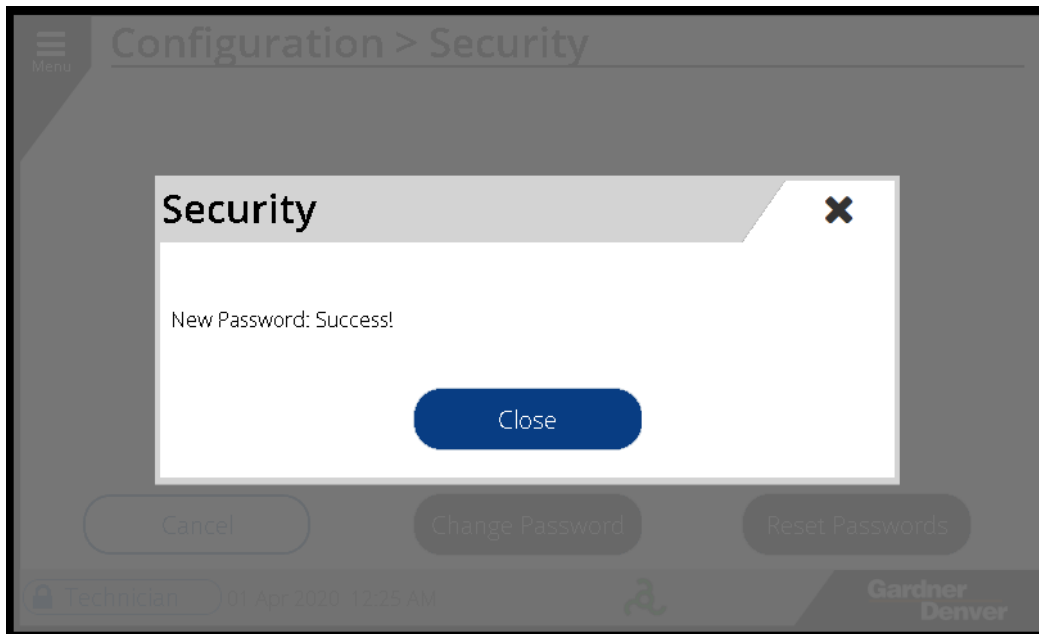

Figure 97: Change Password

On the **Security** home screen, if the user hits the *Reset Password* button, the password will be reset to the factory default password values for the *Technician* and *Maintenance* login.

4.3.5 Advanced

This option is available only with *Technician* and *Factory* level logins.

Logging Level:

There are three logging levels: *Low*, *Medium*, and *High*. These logging levels the level of info included in the system logger, which is valuable for engineering level diagnostics. Do not change this value unless

directed by Gardner Denver service or engineering. One can select the required logging level with the drop down menu as shown in Figure 98 below.

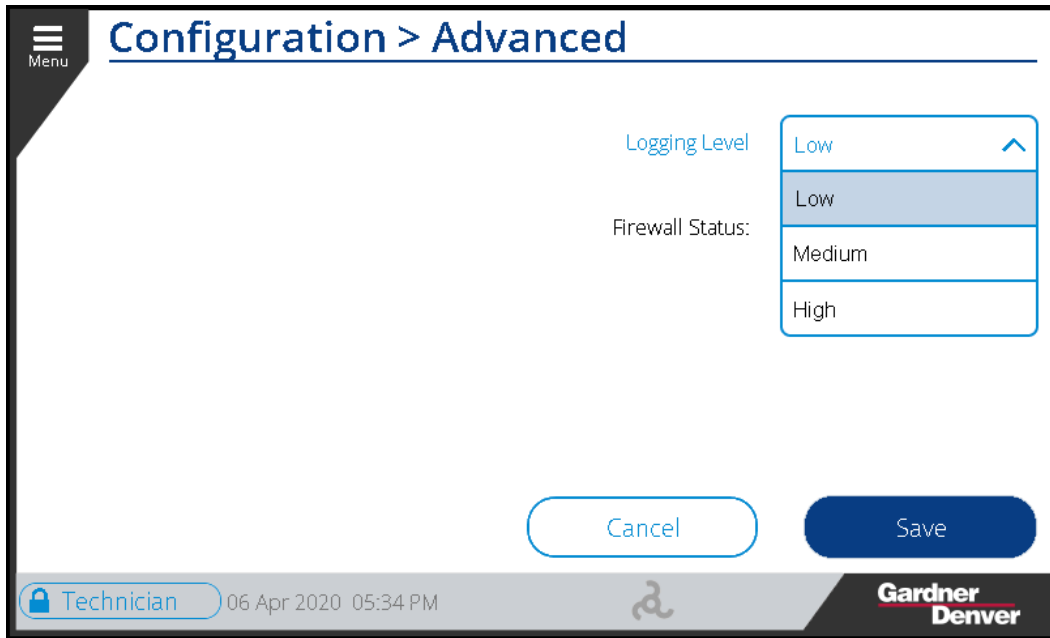

Figure 98: Logging Level

Firewall Status:

The **Firewall Status** setting can be either enabled or disabled with the toggle button. Figure 99 below shows the Firewall *Enable* status. There are specific communication instances where the firewall will need to be disabled on the controller to provide the required access for qualified personnel. The firewall will revert to enabled when the controller is rebooted. Do not change this setting unless directed by Gardner Denver service or engineering.

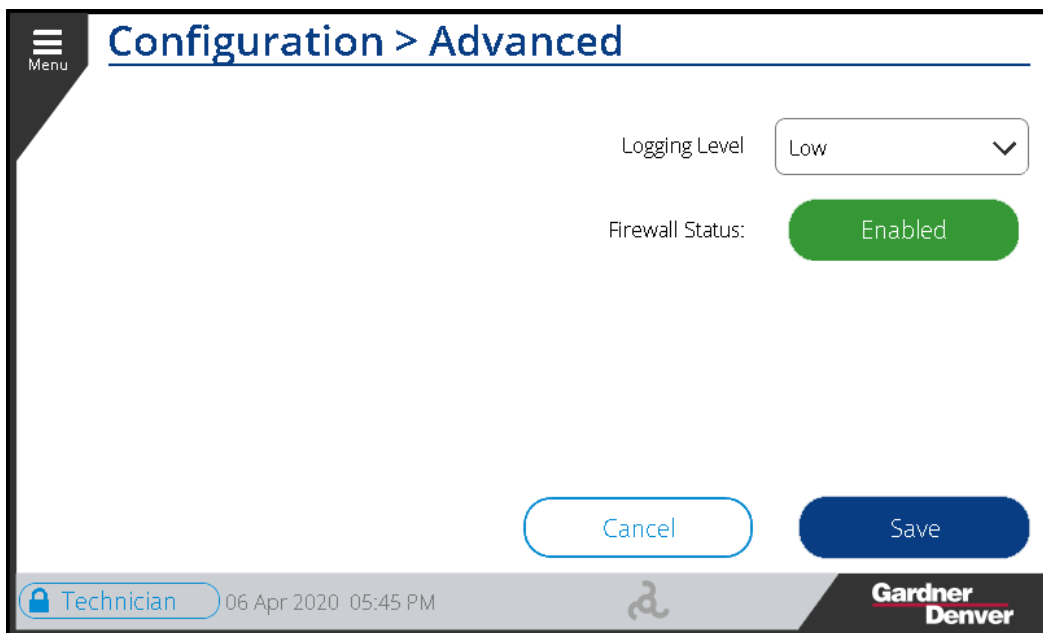

Figure 99: Firewall Status

4.4 Sequencing

The Gardner Denver Governor™ controller is capable of communicating with several different generations of Gardner Denver controls to allow multi-machine sequencing of new and existing Gardner Denver equipment. Depending on the protocol selected, up to 4 or 8 machines may be sequenced on a single installation without the use of a master controller.

Table 34 below shows the settings available under the **Sequencing** menu. Click on the desired setting from the Sub-Menu column to directly jump to the respective setting.

For more comprehensive and detailed information on sequencing of machines, refer to the *Governor Sequencing Manual*, document number **13-17-625**.

Table 34: Sequencing Settings

Sequencing Settings		
Setting	Sub-Menu	Short Description
Sequencing	4.4.1 Sequencing Types:	Gives Information about the different Sequencing Types
	4.4.2 AirSmart Protocol:	Summary of AirSmart Protocol Sequencing Settings
	4.4.3 Delcos Protocol:	Summary of Delcos Protocol Sequencing Settings

4.4.1 Sequencing Types:

Figure 100 outlines the **Sequencing** settings home screen for the *ES+* protocol. This screen will list different settings depending on the sequencing protocol that was selected on the communications screen, refer to Figure 93 above for the different sequencing types available.

As you can see the **Sequencing Type** selection setting is *disabled* on this screen. If you touch **Sequencing Type**, a pop up message will come up saying it can't be configured here and will show the path where it can be found, shown in Figure 101 below.

The screenshot displays the 'Settings > Sequencing' interface. It features a 'Menu' icon in the top left corner. The main content area includes the following settings:

- Sequencing Type:** A dropdown menu currently set to 'ES+' with a downward arrow.
- Number of Units:** A text input field containing the value '4'.
- Transfer Interval:** A text input field containing '1' followed by a unit selector 'h'.
- Unit Number:** A text input field containing the value '2'.
- Lag Start Delay:** A text input field containing '15' followed by a unit selector 's'.

At the bottom of the settings area, there are two buttons: a light blue 'Cancel' button and a dark blue 'Save' button. The bottom status bar shows a lock icon, the text 'Technician', the date and time '01 Apr 2020 12:39 AM', a green logo, and the 'Gardner Denver' brand name.

Figure 100: ES+ Protocol Sequencing Settings

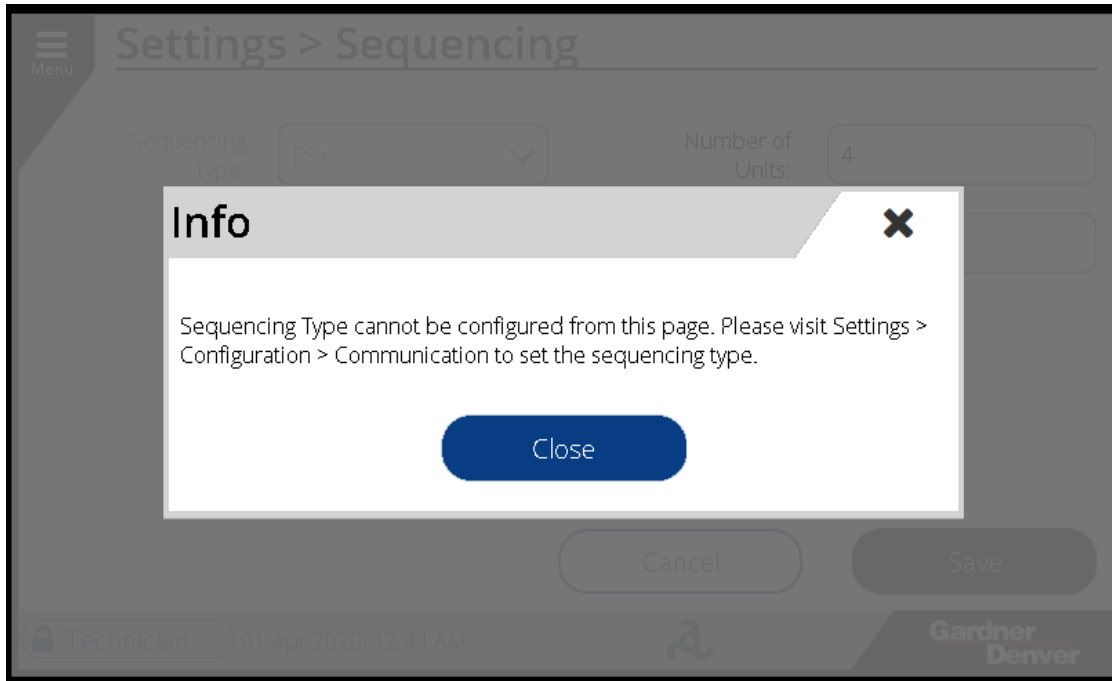

Figure 101: Sequencing Mode Change Info

4.4.2 AirSmart Protocol:

The **AirSmart protocol** is the native protocol for fixed and variable speed compressors using the *AirSmart* or *AirSmart G2* controller. If you are connecting to other Gardner Denver compressors with these controllers, the AirSmart protocol should be used to allow for direct and optimal sequencing control. The AirSmart protocol is uniquely designed to handle sequencing and load sharing of variable speed compressors or a mix of up to 8 variable speed and fixed speed machines. It also features the ability to use a dedicated system pressure input to sample a true network delivery pressure.

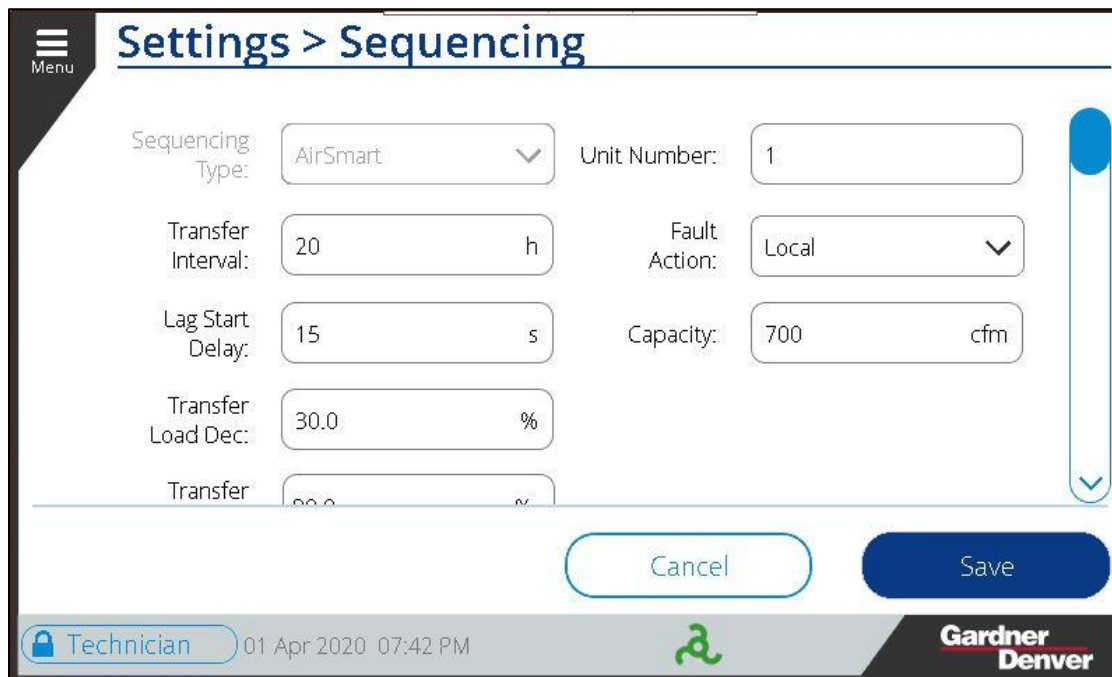

Figure 102: AirSmart Protocol Sequencing Settings

4.4.3 Delcos Protocol:

The **Delcos protocol** is the native protocol for Gardner Denver machines using the *GD Pilot*, *GD Pilot TS*, *GD Pilot XTC*, *Delcos Pro*, *Delcos XL*, and *Delcos XXL* controllers. If you are connecting to other Gardner Denver compressors with one of these controllers, this is the protocol that should be used. It is also the protocol to select if you are using a Gardner Denver *Connect 12™* system controller.

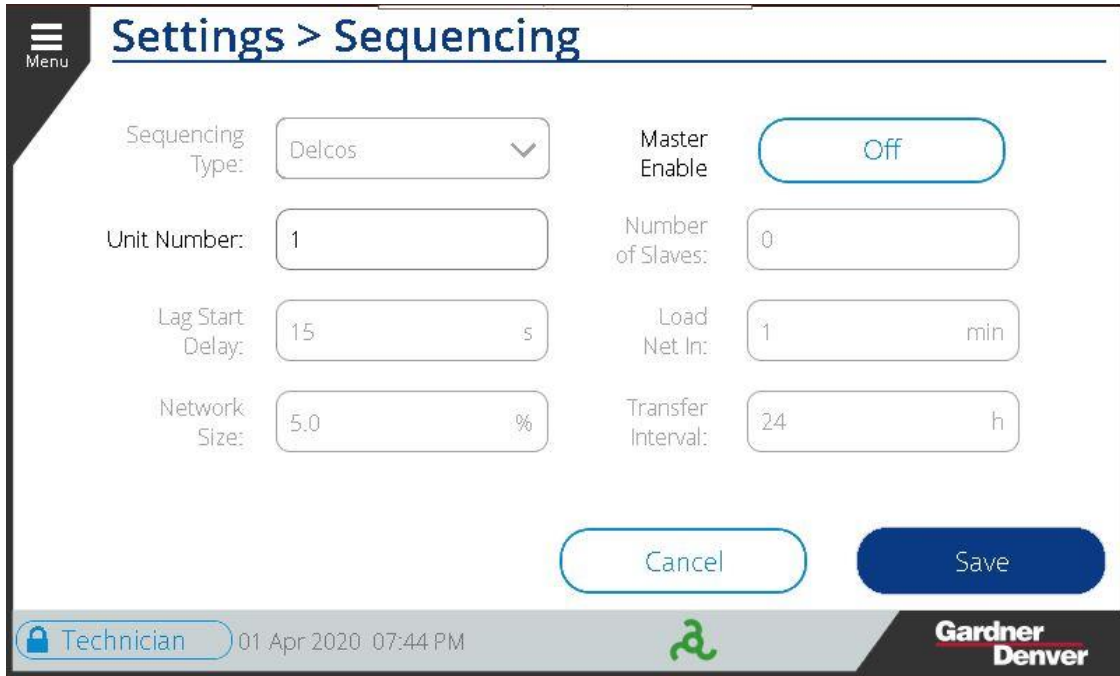

Figure 103: Delcos Protocol Sequencing Settings

4.5 Timer Control

The **Timer Control** feature allows the compressor operation to be modified based on a time schedule. There are two schedules available, one to control starting and stopping of the machine and another to activate the secondary pressure band. Table 35 below lists the timer control settings available under this menu.

Table 35: Timer Control

Timer Control Setting		
Setting	Sub-Menu	Short Description
Timer Control	Set Date, Time and Time Zone	The User can set the Date, Time and Timezone on this screen.
	Pressure Band p2 setting	The User can set the schedule for the secondary pressure band.
	Timer Start and Stop setting	The User can set the schedule to control the starting and stopping of the compressor.

Figure 104 shows the main screen for the **Timer Control** Settings.

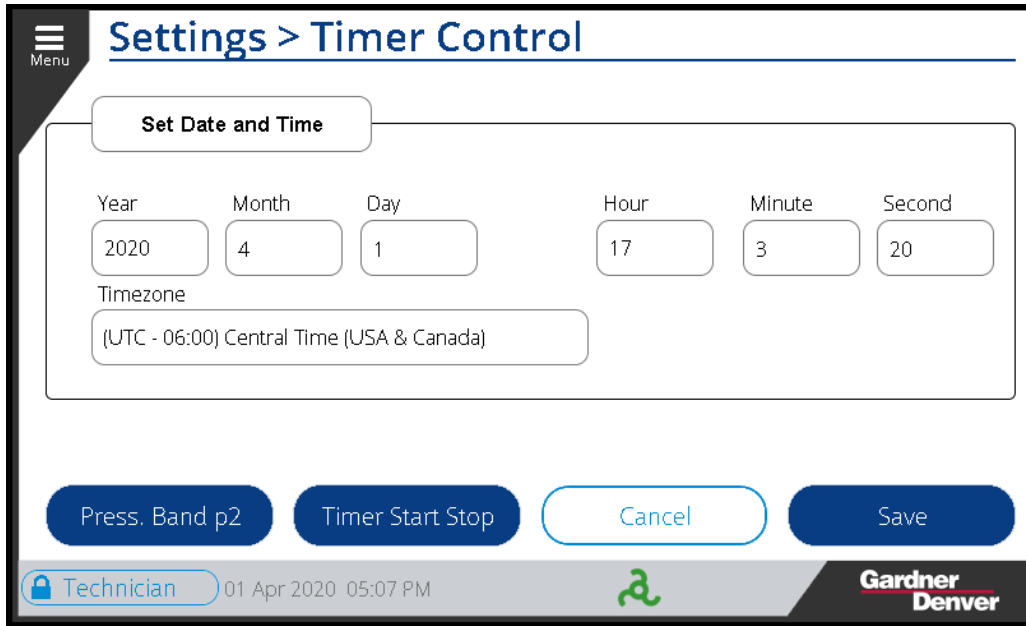

Figure 104: Timer Control

Time can also be set from the *Settings > Configuration > Locale* menu. Refer to Section 4.3.2 for more details, the same logic to change these settings applies.

4.5.1 Timer Start Stop:

Hit the **Timer Start Stop** button and it will bring the user to the **Timer Config** settings. As you can see in Figure 105 below, all the channels are set to *off*. We can set up to 8 different sets of time and days labeled as channels. Each timer control channel controls a compressor switch-on time and a compressor switch-off time that can be set for one or more days of the week.

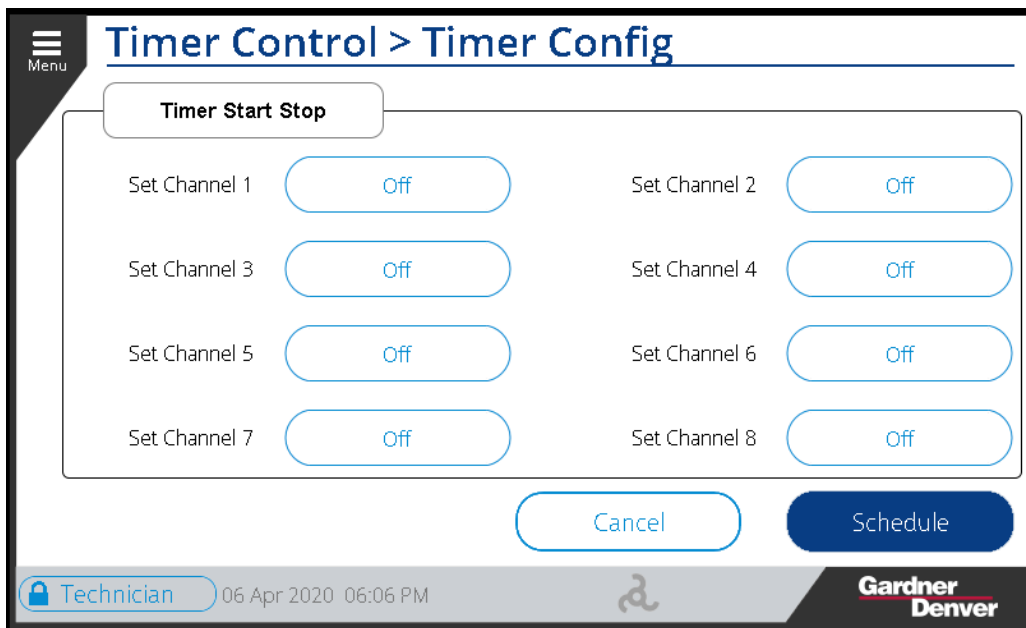

Figure 105: Timer Start Stop

To configure one of the channels, hit the button labeled *Off* next to the channel you want to set. If the channel has already been configured the button will be labeled *On*. This will navigate you to the **Channel Setting Screen** as shown in Figure 106 below.

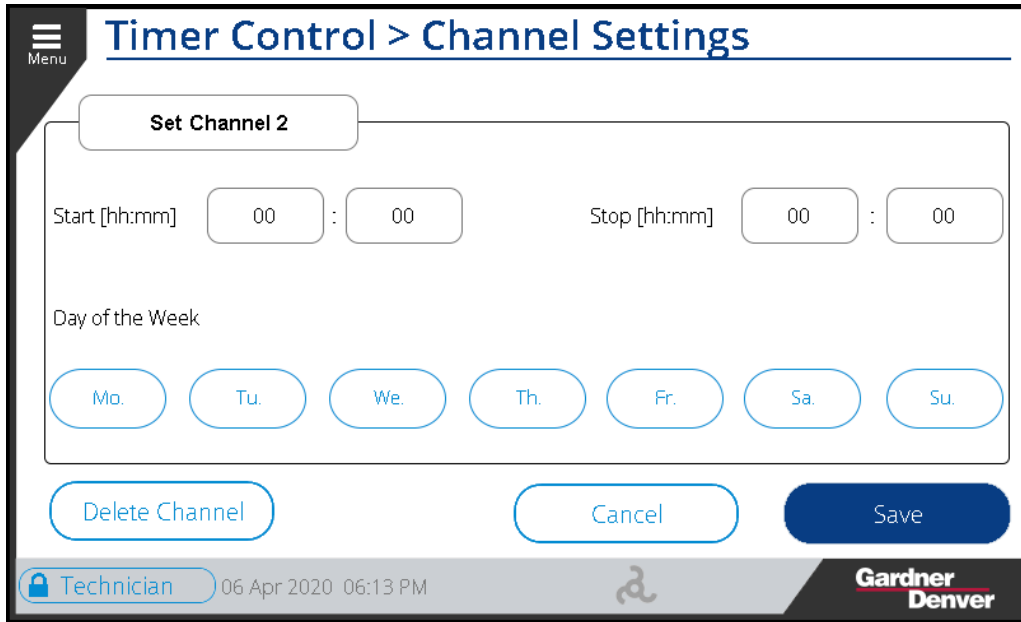

Figure 106: Set Channel 2

User can set the *Start Time*, *Stop time*, and *Days of the week* for compressor operation. We are setting Start time as 08:15, Stop Time 16:45 and days as Mo (Monday), We (Wednesday), Fr (Friday) and Sa (Saturday), for example. Once changed, the screen will look like Figure 107 below.

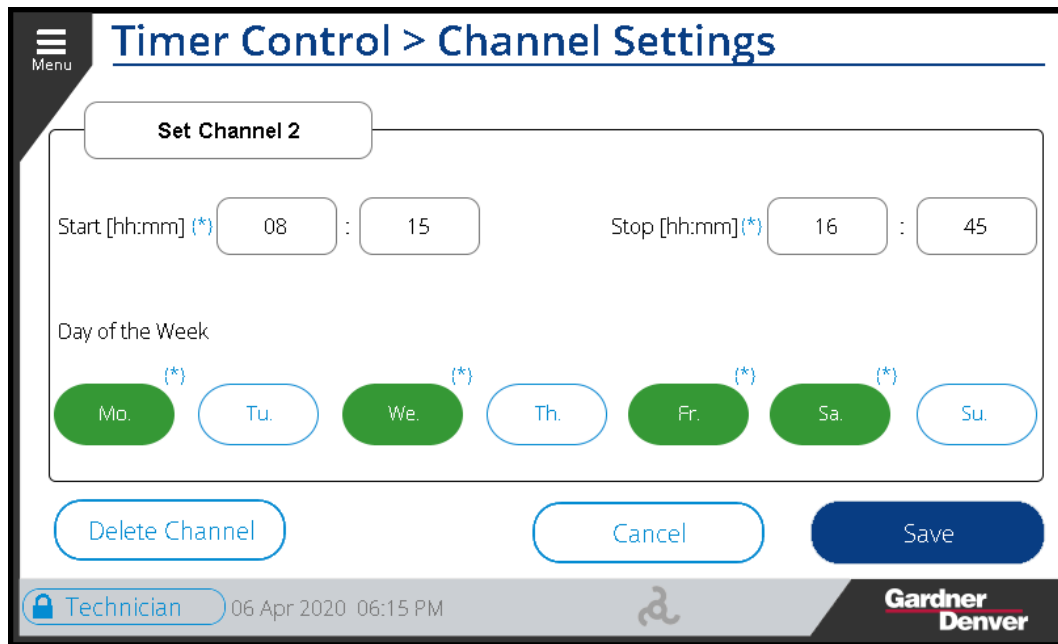

Figure 107: Set Channel 2

Once saved it will bring the user back to the **Timer Config Screen**. Channel 2 is set to *On* now as shown in Figure 108 below.

To turn off the timer channel press the **Delete Channel Button** on the bottom left of this screen, this will delete all the values and bring the user back to the **Timer Config** screen, with the respective channel set to *Off*.

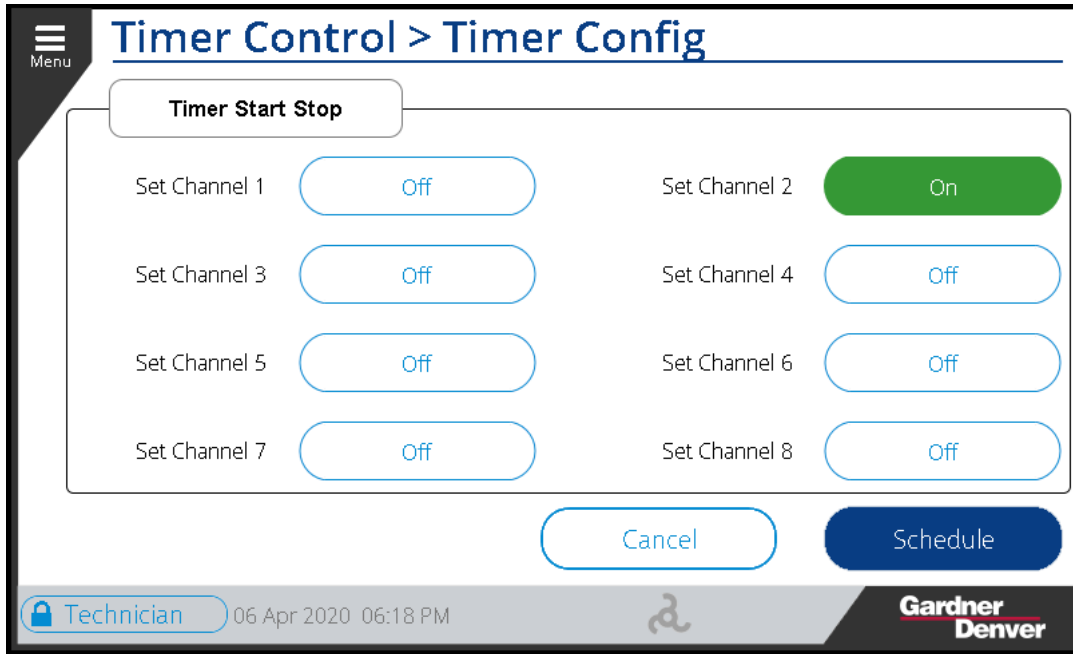

Figure 108: Timer On

Note that any channels with overlapping time will be treated as a continuous timer value.

Press the **Schedule** button to view the current schedule of operation. The green areas shown on the schedule screen are the times when the compressor will be active, shown in Figure 109 below.

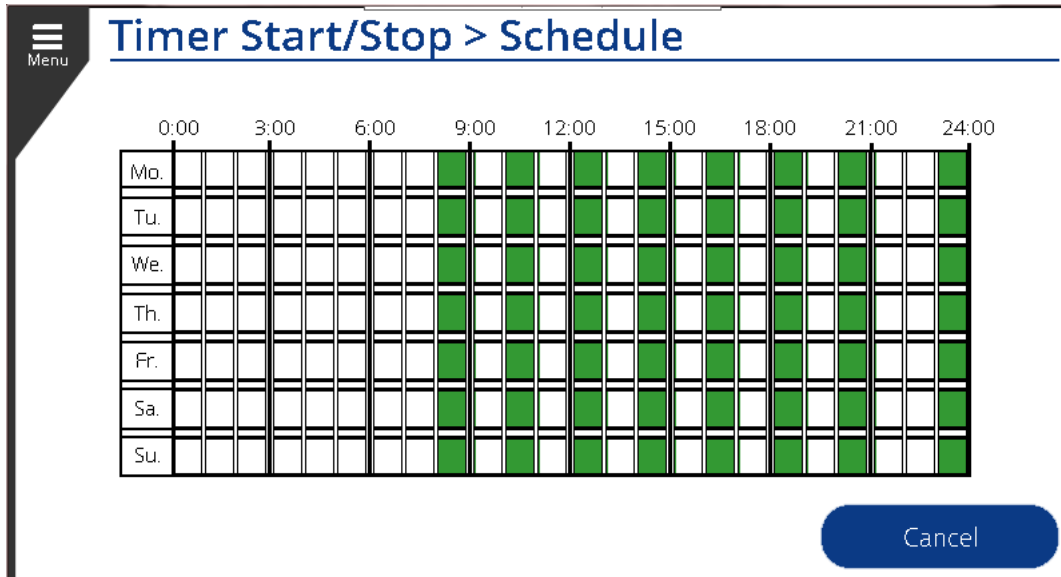

Figure 109: Schedule View

4.5.2 Press Band p2 Timer:

The **Press. Band p2** button on the bottom left side of the **Timer Control** Screen will bring the user to the **Timer Config** screen, this button is shown in Figure 110 below.

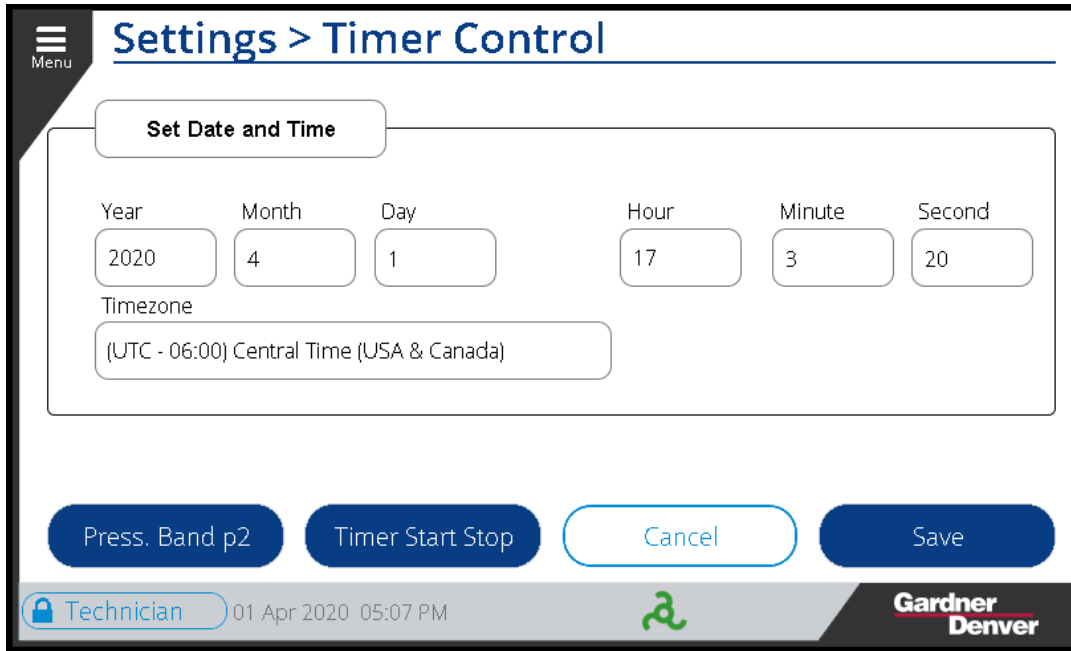

Figure 110: Timer Control

Pressing the button will bring the user to **Timer Config** screen for **Timer Pressure Band p2** as shown in Figure 111 below, all the channels are set to *Off*. We can set up to 8 different sets of time and days labeled as channels. Each timer control channel controls a compressor switch-on time and a compressor switch-off time that can be set for one or more days of the week.

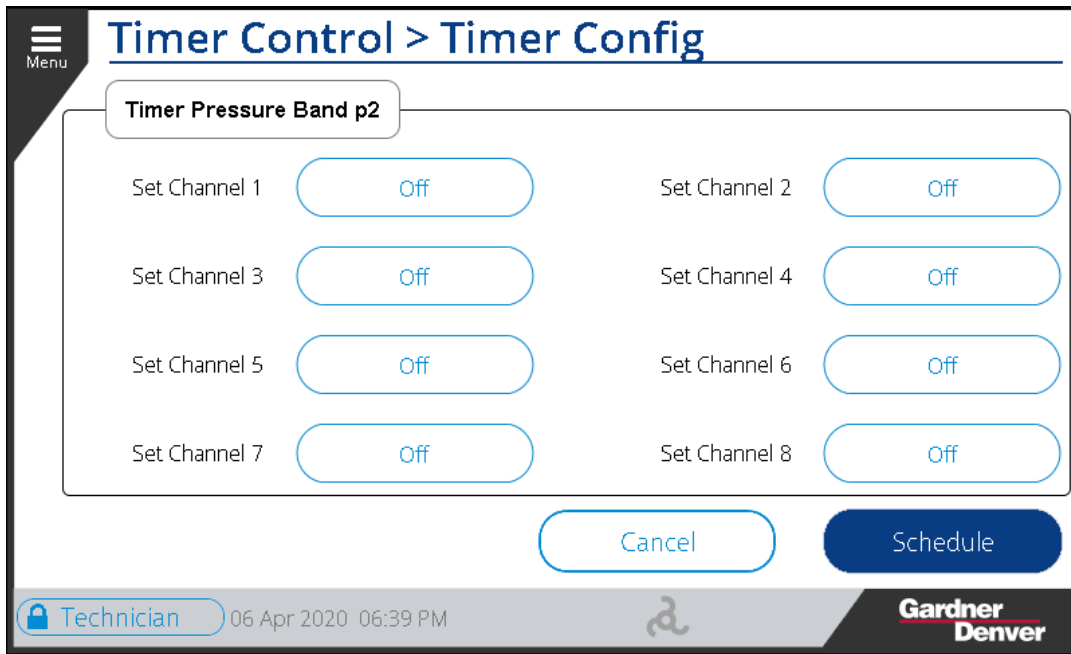

Figure 111 Timer Pressure Band p2

To configure one of the channels, hit the button labeled *Off* next to the channel you want to set. If the channel has already been configured the button will be labeled *On*. This will navigate you to the **Channel Setting Screen** as shown in Figure 112 below.

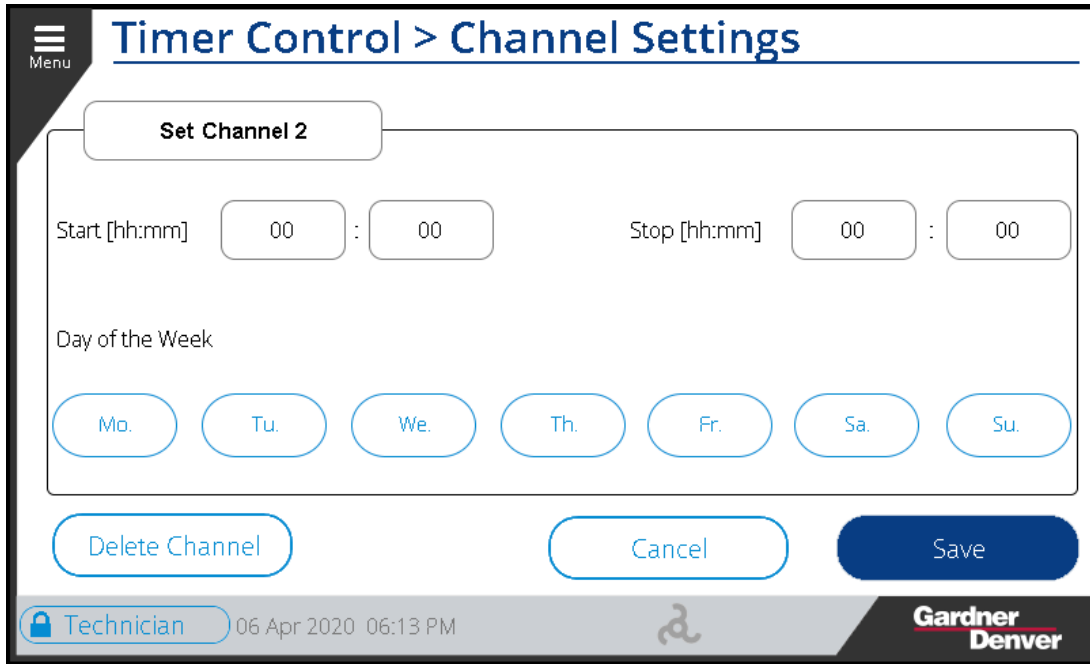

Figure 112: Set Channel 2

The User can set the *Start Time*, *Stop time*, and *Days of the week* for compressor operation. We are setting Start time as 22:30, Stop Time 07:30 and days as Mo (Monday), We (Wednesday), Fr (Friday) and Sa (Saturday), for example. Once changed, the screen will look like Figure 113 below.

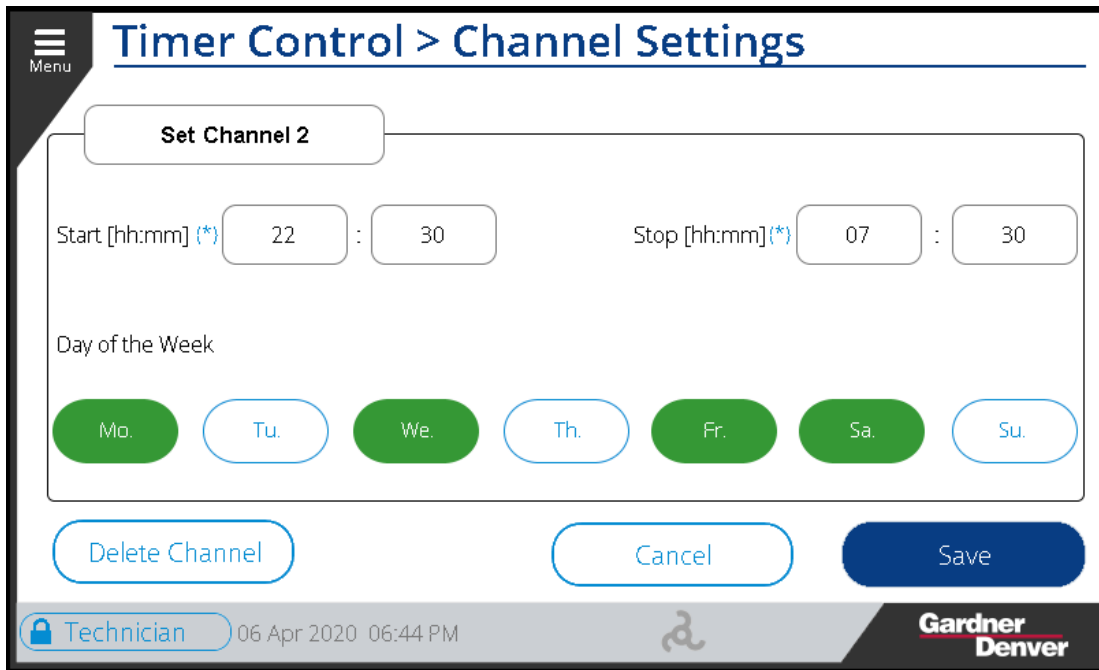

Figure 113: Set Channel 2

Once saved it will bring the user back to the **Timer Config Screen**. Channel 2 is set to *On* now as shown in Figure 114 below.

To turn off the timer channel press the **Delete Channel Button** on the bottom left of this screen, this will delete all the values and bring the user back to the **Timer Config** screen, with the respective channel set to *Off*.

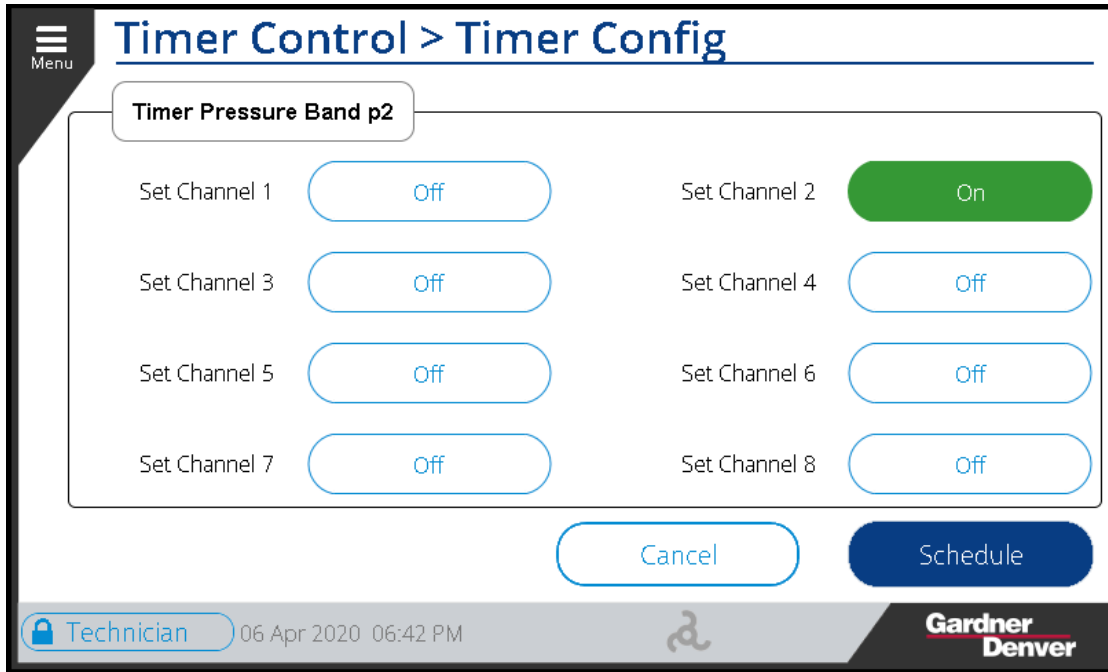

Figure 114: Timer Pressure Band p2 On

Note that any channels with overlapping time will be treated as a continuous timer value.

Press the **Schedule** button to view the current schedule of operation. The green areas shown on the schedule screen are the times when the compressor will be active, shown in Figure 115 below.

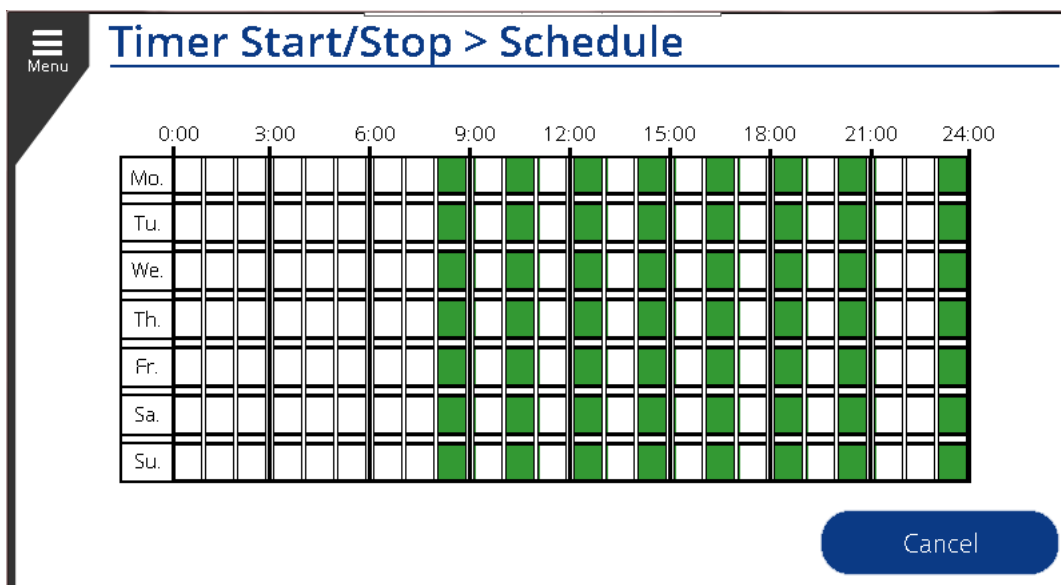

Figure 115: Schedule View

4.6 Programmable I/O

The **Programmable I/O** settings menu allows the user to assign different digital and analog inputs and outputs to any free physical input or output connection on the controller. This is categorized into four sections: *Digital Inputs*, *Digital Outputs*, *Temperature Inputs*, *Analog Inputs*, and *Analog Outputs*.

Table 36: Programmable I/O

Programmable I/O Settings		
Setting	Sub-Menu	Short Description
Programmable I/O	4.6.1 Digital Inputs:	The User can enable or disable and assign digital input signals to available channels.
	4.6.2 Digital Outputs:	The User can enable or disable and assign digital output signals to available channels.
	4.6.3 Temperature Inputs:	The User can enable or disable and assign temperature input signals to available channels.
	4.6.4 Analog Inputs:	The User can enable or disable and assign analog input signals to available channels.
	4.6.5 Analog Outputs:	The User can enable or disable and assign analog output signals to available channels.

Table 36 above lists the sub-menus of the **Programmable I/O** sections.

4.6.1 Digital Inputs:

The **Digital Input** tab lists 14 parameter settings and each can be assigned a channel based on their position on the IO module. Figure 116 below shows the screen for the **Digital Inputs**. Next to each signal name, there is an input box to set the channel value and a toggle to set the signal as *high* or *low*.

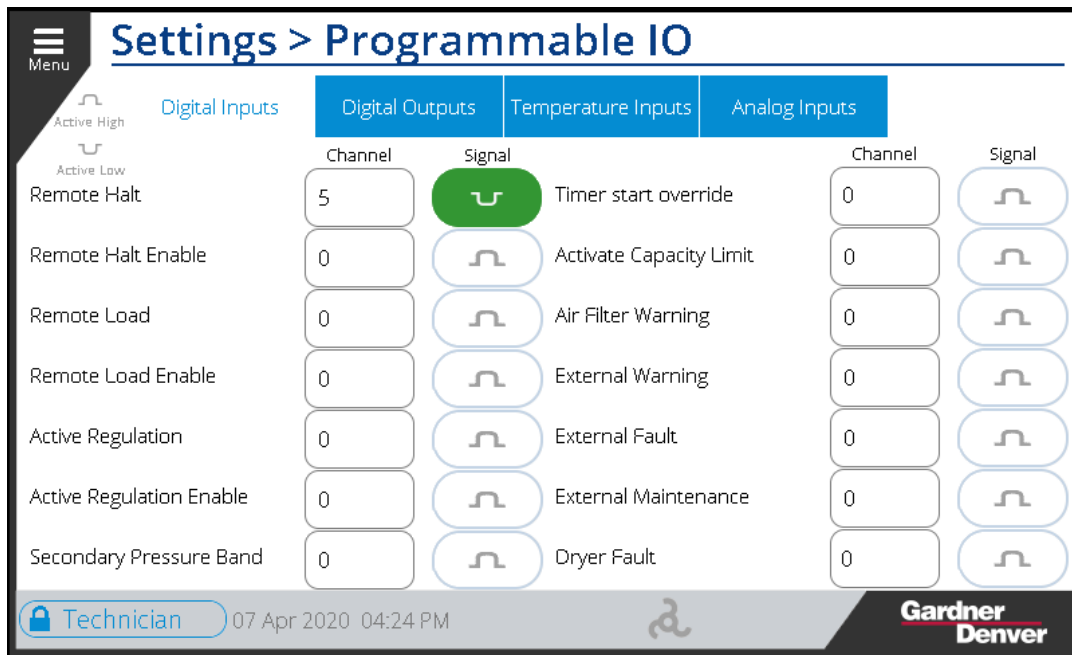

Figure 116: Digital Inputs

The **Remote Halt** signal has been assigned to *Channel 5* and is an *Active Low* signal, for the example above.

The **Remote Halt Enable** has not been assigned to a channel, so it is set to '0' or disabled. To activate the **Remote Halt Enable**, tap the input box to assign a channel. Now the user can toggle this signal as active high or active low depending on the operating logic required. Refer Figure 117 and Figure 118 below.

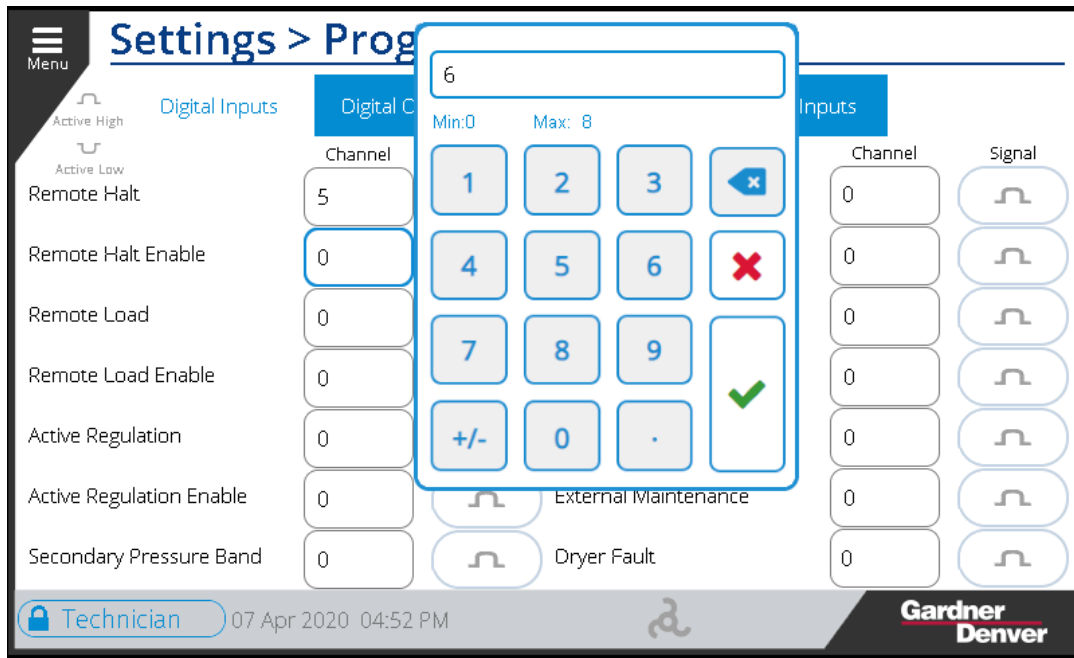

Figure 117: Setting Channel

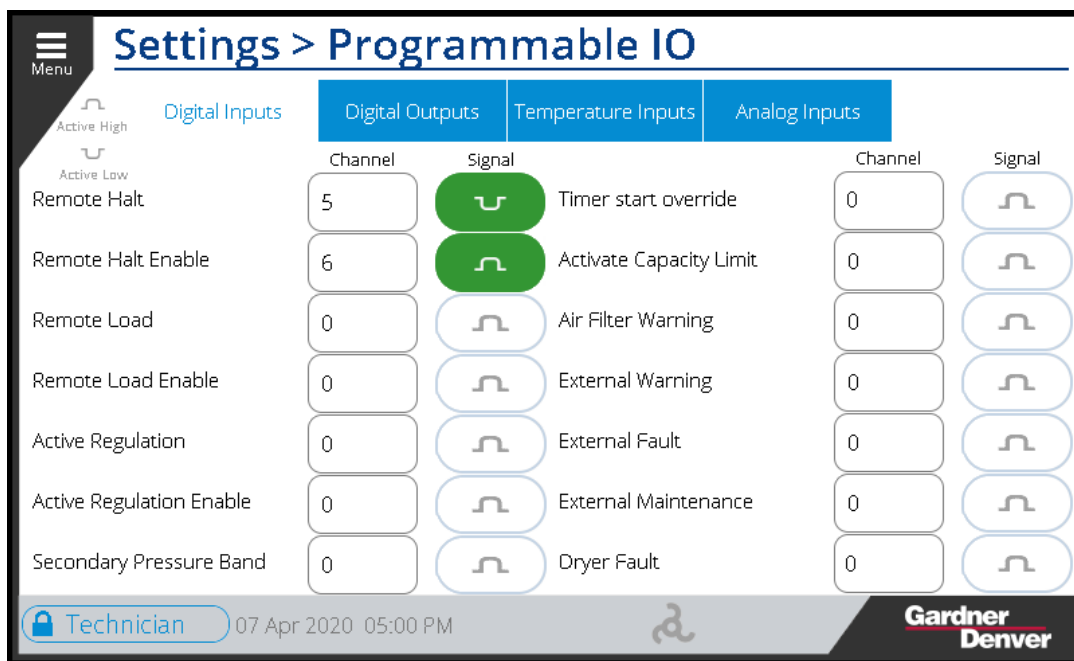

Figure 118: Setting Signal

Active High and Active Low Signal



In the system, digital signals are specified as either Active High  or Active Low . An Active High signals means the function that is assigned to the pin will be active if there is a positive voltage on the input. An Active Low signals means the function that is assigned to the pin will be active if there is a low voltage on the input. For example, with the **Remote Halt** signal shown above configured as active low, **Remote Halt** will be on when there is zero volts on input number 5 and will be off when there is 24VDC on input number 5.

Table 37 below lists the signals available on the Digital Input Signals screen and a brief description of their function.

Table 37: Digital Inputs

Digital Input Signals	
Signal Name	Function
Remote Halt	This function can be used to stop the machine using a digital input. The method used to stop the machine will depend on the Remote Halt Mode setting, which can be either <i>Timed</i> or <i>Immediate</i> . If set to <i>Timed</i> , the machine will unload and blowdown using its configured timers if it is running when the Remote Halt signal becomes active. If set to <i>Immediate</i> , the machine will immediately depressurize and perform a soft stop when the Remote Halt signal becomes active. The machine will not start if the Remote Halt signal is active.
Remote Halt Enable	If this function is assigned to an input and is active, the Remote Halt functionality will be enabled. If it is not active, the Remote Halt signal will be ignored.
Remote Load	This function will cause the compressor to load immediately if the current delivery pressure is below the unload pressure setpoint on the machine. If it is assigned but inactive, the machine will unload immediately and will act as if the pressure unload setpoint has been exceeded.
Remote Load Enable	If this function is assigned to an input and is active, the Remote Load functionality will be enabled. If it is not active, the Remote Load signal will be ignored.
Active Regulation	This function will cause the compressor to immediately unload if it is assigned to an input and not active. If it is active, normal pressure regulation will be enabled.
Active Regulation Enable	If this function is assigned to an input and is active, the Activate Regulation functionality will be enabled. If it is not active, the Activate Regulation signal will be ignored.
Turn Valve Full Open	This function will cause a machine with turn valve modulation to force the turn valve to the full open position (minimum flow).
Turn Valve Full Close	This function will cause a machine with turn valve modulation to force the turn valve to the full closed position (maximum flow).
Inlet Modulation Mode	This function will disable the inlet modulation functionality if active, and the machine will run in load / unload mode. If assigned to an input and not active, the inlet valve will be allowed to modulate.
Secondary Pressure Band	This function enables the secondary (P2) pressure band when it is active.
Timer Start Override	This function is used to override the Timer Start / Stop functionality. For example, if a machine is set to start at 6AM but needs to be started at 5:30AM, a digital input set to this function could be used to override the timer functionality and allow the machine to start without reconfiguring the settings on the controller. This is an edge-triggered input that does not need to remain active after the machine starts (it can be tied to a momentary signal or push button).
Active Capacity Limit	This function is used to activate the capacity limits set in the HMI for minimum and maximum speed will be activated.
Separator Warning	If this digital input is active, a separator warning will be triggered.
Separator Fault	If this digital input is active, a separator fault will be triggered.
Dryer Running	This function provides running status feedback from a connected dryer. If the input is assigned, a dryer aux contact fault will be triggered if the dryer does not provide running feedback after the dryer start output is activated.
Dryer Warning	If this digital input is active, a dryer warning will be triggered.
Dryer Fault	If this digital input is active, a dryer fault will be triggered.
Air Filter Warning	If this digital input is active, an air filter warning will be triggered.
External Warning	If this digital input is active, an external warning will be triggered. This can be connected to any general condition that does not fall under the available programmable functions on the controller.
External Maintenance	If this digital input is active, an external maintenance alarm will be triggered. This can be connected to any general condition that does not fall under the available programmable functions on the controller.
External Fault	If this digital input is active, an external fault condition will be triggered. This can be connected to any general condition that should stop the compressor that does not fall under the available programmable functions on the controller.

Belt Break Fault	If this digital input is active, a belt break fault will be triggered. This can be tied to a belt break or proximity sensor which would sense a broken drive belt.
Safety Switch Fault	If this digital input is active, a safety switch fault will be triggered.
Low Voltage Relay Warning	If this digital input is active, a low voltage warning will be triggered.
Low Voltage Relay Fault	If this digital input is active, a low voltage fault will be triggered.
Phase Sequence Fault	If this digital input is active, a phase sequence fault will be triggered. This is typically connected to a phase fault relay.
High Vibration Warning	If this digital input is active, a high vibration warning will be triggered. This is typically connected to a vibration switch mounted on the compressor or motor.
High Vibration Fault	If this digital input is active, a high vibration fault will be triggered. This is typically connected to a vibration switch mounted on the compressor or motor.
Enclosure Temperature Warning	If this digital input is active, an enclosure temperature warning will be triggered. This is typically used to monitor the temperature inside the machine enclosure and protect against high ambient temperature, dirty package air filters, or cooling fan faults.
Enclosure Temperature Fault	If this digital input is active, an enclosure temperature fault will be triggered. This is typically used to monitor the temperature inside the machine enclosure and protect against high ambient temperature, dirty package air filters, or cooling fan faults.
Oil Filter Warning	If this digital input is active, an oil filter warning will be triggered. This is typically used to indicate a clogged or defective filter.
Oil Temperature Warning	If this digital input is active, an oil temperature warning will be triggered.
Oil Temperature Fault	If this digital input is active, an oil temperature fault will be triggered.
Oil Pressure Warning	If this digital input is active, an oil pressure warning will be triggered.
Oil Pressure Fault	If this digital input is active, an oil pressure fault will be triggered.
Water Pressure Warning	If this digital input is active, a water pressure warning will be triggered. This is typically utilized to monitor cooling water pressure on water-cooled machines.
Water Pressure Fault	If this digital input is active, a water pressure fault will be triggered. This is typically utilized to monitor cooling water pressure on water-cooled machines.
Condensate Drain Warning	If this digital input is active, a condensate drain warning will be triggered.
Condensate Drain Fault	If this digital input is active, a condensate drain fault will be triggered.
Reset Alarms	This function is used to acknowledge all active alarms on the system. The functionality is identical to pressing the Reset All button on the Alarms page.
OK to Start	This function is used as a start permissive for the controller. If it is assigned and not active, the compressor will not start the motor until this signal becomes active.
OK to Load	This function is used to delay opening the inlet valve on a compressor until it becomes active.
Motor Lubrication System	This function is used to monitor Gardner Denver automatic motor lubrication systems. A set of controls and monitoring logic is tied to this input that monitor the automatic lubricator for proper operation and fault signals.

4.6.2 Digital Outputs:

Figure 119 below shows the **Digital Outputs** Tab. As discussed for the **Digital Inputs** in Section 4.6.1, The User can set the *Channel* and *Signal type* for each **Digital Output** signal.

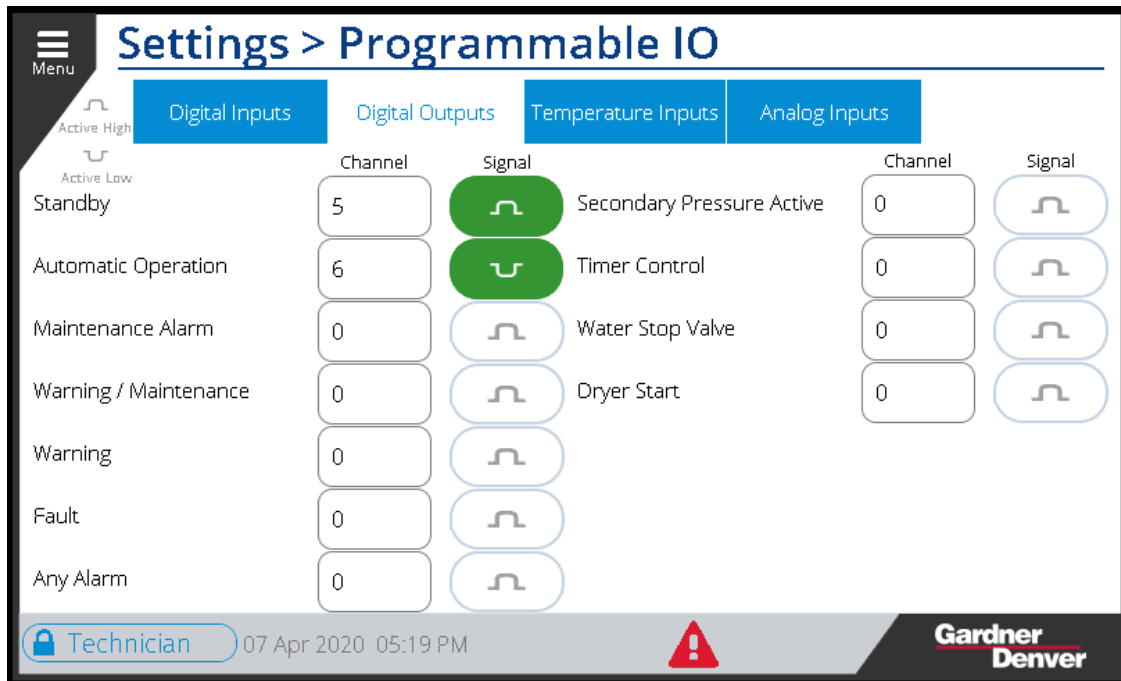



Figure 119: Digital Outputs

Active High and Active Low Signal

In the system, digital signals are specified as either Active High  or Active Low . An Active High output means that the pin assigned to the output will be turned on when the function assigned to the pin is active. An Active Low output means that the pin assigned to the output will be turned off when the function assigned to the pin is active.

For example, with the **Standby** signal shown above configured as active high, the output pin number 5 will be switched on (24Vdc) when the machine is in a standby state.

Table 38 below lists the signals available on the **Digital Outputs** Signals screen and a brief description of their function.

Table 38: Digital Outputs

Digital Outputs	
Signal Name	Function
Standby	This signal indicates that the machine is in an enabled state, but is not running the motor.
Automatic Operation	This signal indicates that the machine is enabled and the motor may be stopped or running. The machine can start up at any time.
Motor Running	This signal indicates that the main motor is running.
Loaded State	This signal indicates that the compressor is loaded and producing air (inlet valve is open).
Unloaded State	This signal indicates that the compressor is unloaded (inlet valve is closed).
Blowdown State	This signal indicates that the compressor is in the blowdown state. On some machines, this is the same as the unloaded state, but machines that have direct control over the blowdown valve may run unloaded prior to depressurizing the reservoir.
Maintenance Alarm	This signal indicates that the machine requires maintenance or service. An active warning for a service item has been detected. This may be due to a condition-based alarm (such as Air Filter vacuum), or a maintenance timer / counter.
Warning / Maintenance	This signal indicates that a warning or maintenance alarm is present on the system.

Warning	This signal indicates that a warning other than a maintenance alarm is present on the machine.
Fault	This signal indicates that a fault is present on the system. Note that an output that is not powered by the ESTOP must be used for the programmable output channel for this signal to remain active during an ESTOP fault.
Any Alarm	This signal indicates that an alarm is present on the machine. Any fault or warning will trigger this output.
Secondary Pressure Active	This signal indicates that the secondary pressure band is currently active, due to the Secondary Pressure Timer or digital input.
Timer Control	This signal indicates that the compressor is operating under timer control.
Request to Start	This signal can be used in conjunction with the OK to Start digital input function. If the controller needs to start the motor due to conditions such as pressure requirement, it will activate this output.
Request to Load	This signal can be used in conjunction with the OK to Load digital input function. If the controller needs to load the machine, it will activate this output.
Water Stop Valve	This function is used to control a water valve on water-cooled machines. Depending on the configuration of the machine, the water stop valve may be controlled continuously or through a thermostatic algorithm based on the discharge temperature of the compressor.
Condensate Drain	This function is used to control a condensate drain. An internal timer and additional logic is used to activate the drain output periodically.
Heater Start	This function is used to control an external heater based on the various temperature readings on the package.
Dryer Start	This signal is used to start an external dryer. It is used in conjunction with the Dryer Pre-run Time control setting, as well as the Dryer running digital input, if desired.
External Reset	This signal is used to send a reset command to an external device. This is tied to the Reset All button on the Alarm page used to acknowledge faults and warnings.
Motor Lubrication	This signal is used to control Gardner Denver automatic motor lubrication systems. Use of this output should always be combined with the Motor Lubrication digital input function for monitoring.

4.6.3 Temperature Inputs:

The **Temperature Inputs** settings page allows configuring optional temperature inputs to the controller as shown in Figure 120 below.

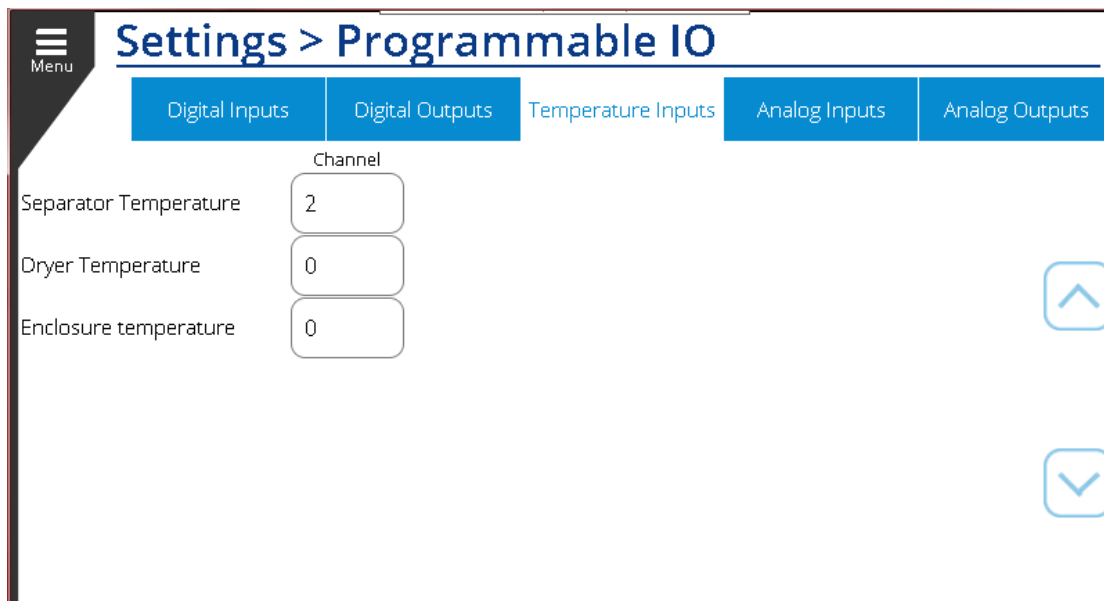

Figure 120: Temperature Inputs

Table 39 below lists the signals available on the **Temperature Inputs** screen and a brief description of their function.

Table 39: Temperature Inputs

Temperature Inputs	
Signal Name	Function
Separator Temperature	This temperature signal monitors the temperature after the air-oil separator. If assigned, the controller will monitor this input for temperature-based warnings and faults using the same warning and fault levels configured for the machine discharge temperature.
Dryer Temperature	This temperature signal monitors the temperature of an external dryer for warning or fault. When this function is assigned, additional temperature values can be set on the Settings -> Advanced -> Operating Limits page.
Enclosure Temperature	This temperature signal monitors the temperature of the package enclosure for warning or fault. When this function is assigned, additional temperature values can be set on the Settings -> Advanced -> Operating Limits page.

4.6.4 Analog Inputs:

The **Analog Inputs** settings page allows the user to configure optional analog inputs to the controller. Figure 121 below shows the **Analog Inputs** tab.

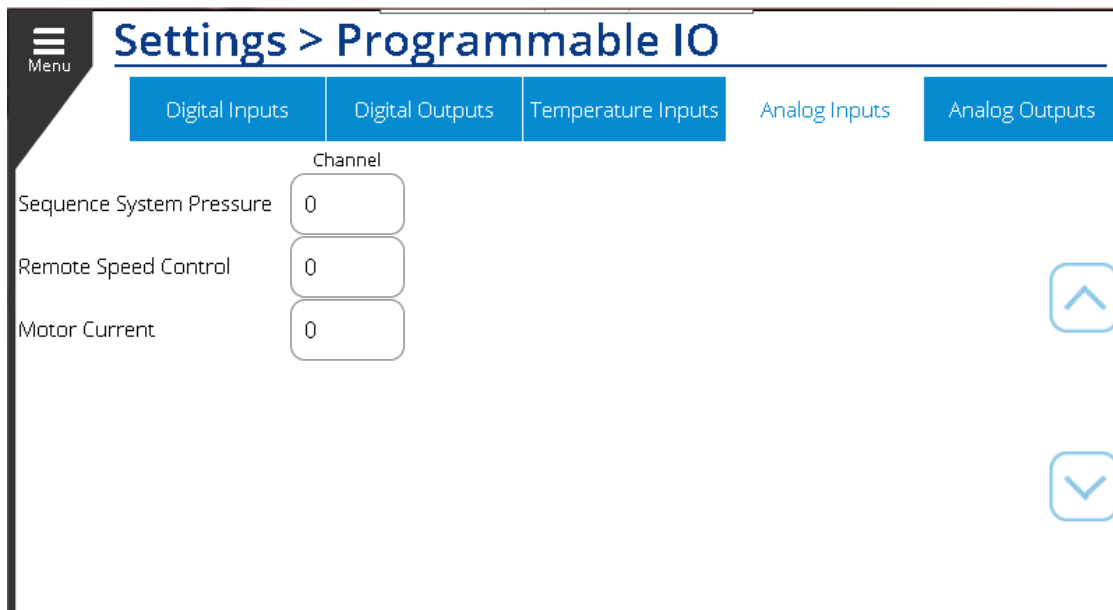

Figure 121: Analog Inputs

Table 40 below lists the signals available on the **Analog Inputs** screen and a brief description of their function.

Table 40: Analog Inputs

Analog Inputs	
Signal Name	Function
Sequence System Pressure	This input is used in the AirSmart sequencing protocol to monitor the pressure at the common tank connected to the compressors in the network.

Remote Speed Control	This input can be used to control the speed of a variable speed compressor. If the input is at 4 mA, the controller will run the motor at the minimum speed possible for the current conditions. If the input is at 20 mA, the controller will run the motor at the maximum speed possible for the current conditions. In between these two values, the controller will scale the speed linearly between minimum and maximum based on the input signal. Note that the Speed Source must be set to Remote on the Settings -> Advanced -> Control page for this function to control the speed of the compressor.
Motor Current	This input is used to monitor the current of the main compressor motor. When this input is present, the Motor SFA setting will be used to monitor the motor for high current, and on some machines will be used to adjust machine operation to reduce motor current (for example if a turn valve is present).

4.6.5 Analog Outputs:

The **Analog Outputs** tab consists of five signal settings which are shown below in Figure 122. Here the user can assign channels to various analog outputs on the compressor.

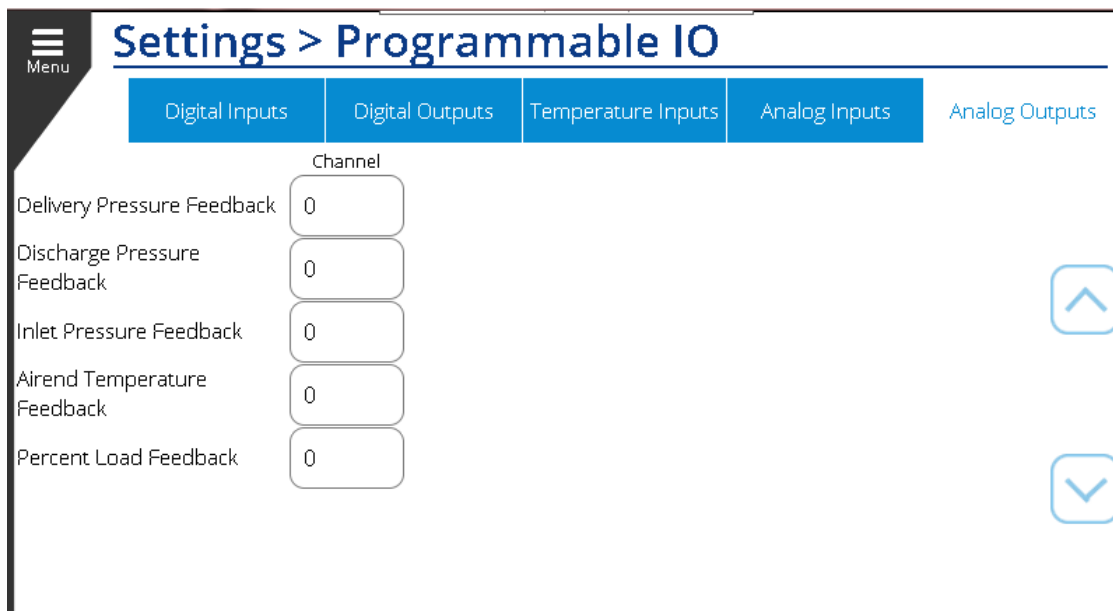

Figure 122: Analog Outputs

Table 41 below lists the signals available on the **Analog Outputs Signals** screen and a brief description of their function.

Table 41: Analog Outputs

Analog Output Signals	
Signal Name	Function
Delivery Pressure Feedback	This output can be used to monitor the existing value of the analog input for delivery pressure. The scaling of the output matches the scaling of the delivery pressure sensor. For most machines, this is as follows: 4mA = -1 bar gauge and 20 mA = 15 bar gauge.
Discharge Pressure Feedback	This output can be used to monitor the current value of the analog input for discharge pressure on machines that have a discharge pressure sensor. The scaling of the output matches the scaling of the discharge pressure sensor. For most machines, this is as follows: 4 mA = -1 bar gauge and 20 mA = 3 bar gauge.

Inlet Pressure Feedback	This output can be used to monitor the current value of the analog input for inlet pressure on machines that have an inlet pressure sensor. The scaling of the output matches the scaling of the inlet pressure sensor. For most machines, this is as follows: 4 mA = 0 bar absolute and 20 mA = 1 bar absolute.
Airend Temperature Feedback	This output can be used to monitor the current value of the temperature input for airend discharge temperature. The scaling of the output is linear between 0 degrees C and the factory maximum fault setting. On most machines, this will be equal to: 4 mA = 0 C (32 F) and 20 mA = 115.56 C (240 F).
Percent Load Feedback	This output can be used to monitor the current value of percent load on a variable speed machine. The scale of the output is linear between 4mA = 0% load and 20 mA = 100% load.

4.7 Advanced

There are five sub-menus in the **Advanced** settings menu: *Setup, Operating Limits, Control, Cooling, and Backup / Restore.*

Table 42: Advanced Settings

Advanced Settings		
Setting	Sub-Menu	Short Description
Advanced	4.7.1 Setup:	The User can setup the Model Name, Serial Number, Design Pressure, Max Volume Flow, Oil Type, System Voltage, Motor SFA, Elevation, Total Hours, Loaded Hours and Brand
	4.7.2 Operating Limits:	The User can set the operating limits for Max Start Pressure, Heavy Startup, Minimum State Temperature, Discharge Temperature Warning, Delivery Pressure Warning, Discharge Temperature Fault and Delivery Pressure Fault.
	4.7.3 Control - Default:	The User can set the Automatic Stop Time, Rotation Direction Check, Min Stop Time, Minimum Run Time, Acceleration Time and Star / Delta Time.
	4.7.5 Cooling - Default:	The User can set and select the Cooling Type and cooling Fan Control.
	4.7.4 Control – Variable Speed:	The User can set advanced control and cooling options for variable speed drive, when applicable.
	4.7.6 PID Tuning:	The User can set advanced PID tuning options.
	4.7.7 Backup / Restore:	The User can perform backup and restore tasks like Save User Configuration, Restore User Configuration and Restore Factory Defaults.

Table 42 above lists the sub-menus of the **Advanced** settings menu.

4.7.1 Setup:

These settings are intended to be set/modified by authorized personnel having the Technician and Factory Login. Please contact Gardner Denver for assistance if you are not sure about these settings. Figure 123 shows the **Advanced Setup** home screen.

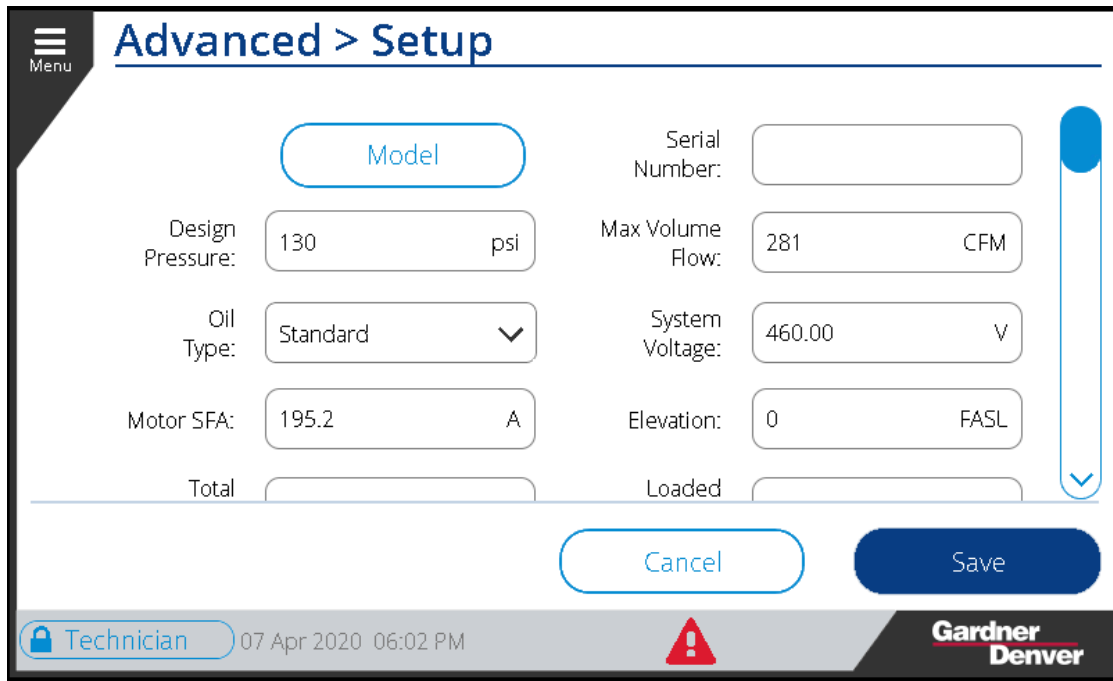

Figure 123: Advanced Setup

4.7.1.1 Model:

The **Model** button on the advanced setup menu brings the user to the *Machine Definition* and *Configuration* files selection screen. This is where machine configurations are loaded based on the system requirements and type of machine being set up. Hit the **Model** button on the **Setup** home screen as shown in Figure 123: Advanced Setup above. The **Model** selection screen that comes up is shown in Figure 124 below.

A combination of two configuration files are used to configure the controller for a particular machine model. The first file that must be loaded is the *Machine Definition* file, this specifies the type of machine, the IO mapping, and the features of the machine. The second file that is loaded is the *Machine Config File*, this specifies a particular variant of the chosen machine, for example the voltage and power variant for a variable speed machine.

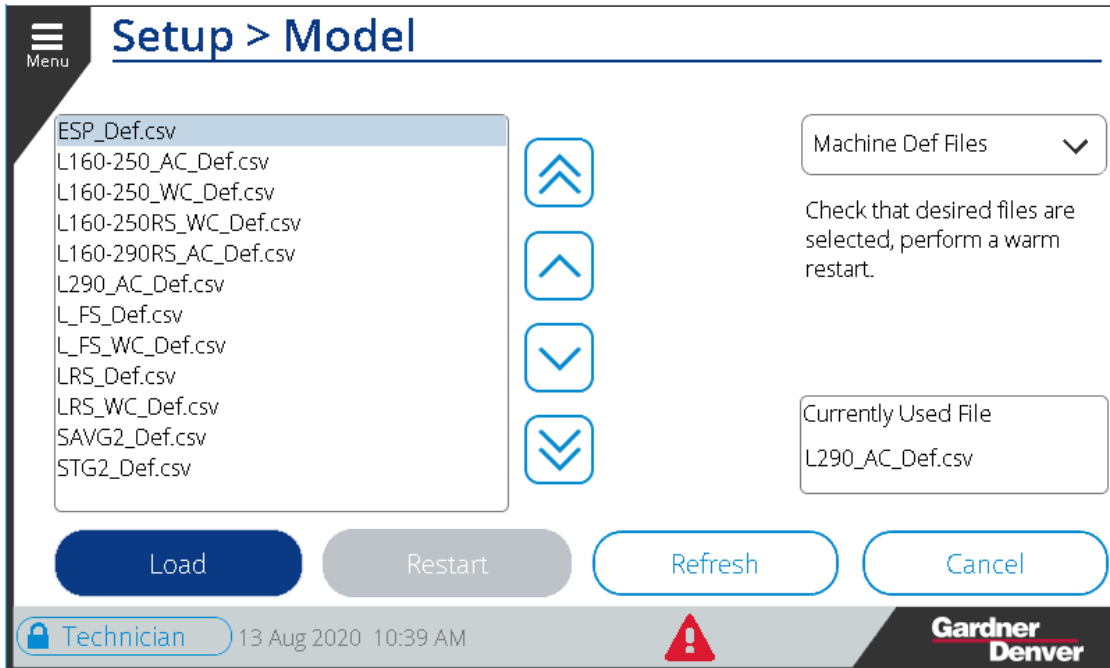

Figure 124: Model Setting

The drop down menu on the left hand side of this screen lists two options as shown in Figure 125: *Machine Def Files* and *Machine Config Files*. The left side of this screen lists all of the different Machine Def Files or Machine Config Files, depending on which is selected from the drop-down menu.

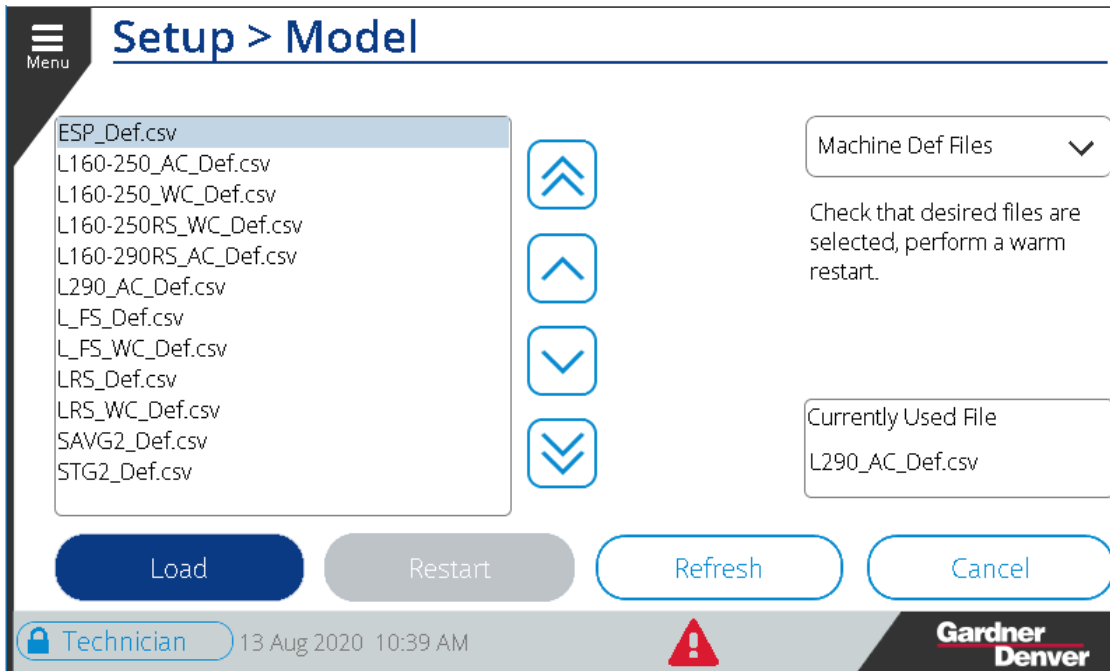

Figure 125: Model Setting

The bottom right text box will show the currently used file for each of the respective selections. With the up and down scroll buttons, users can browse through the list of files. Figure 126 below shows the list of available Machine Definition Files. Figure 127 below shows the list of available Machine Configuration Files for this particular controller.

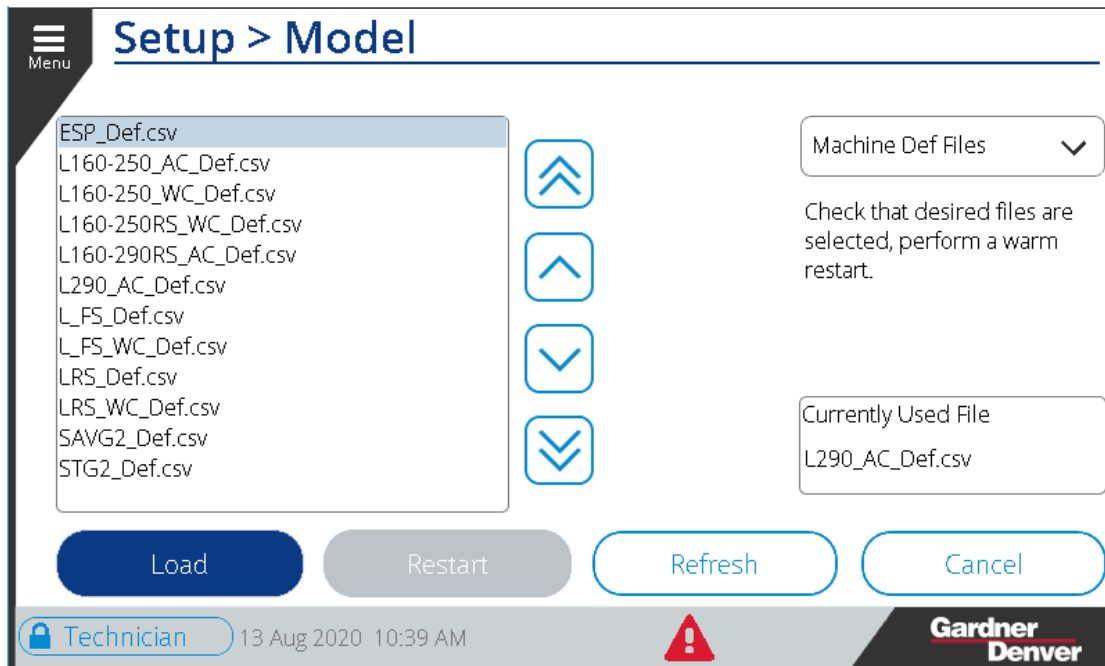

Figure 126: Model Setting

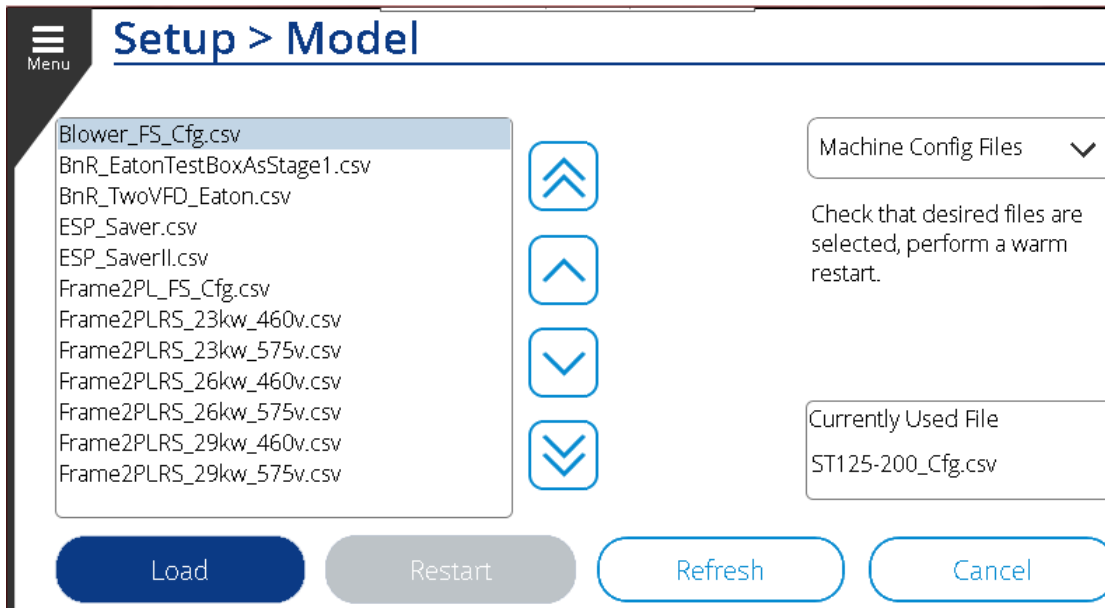

Figure 127: Model Setting

Once the desired file is selected under each of the options from the drop down menu, hit the **Load** Button to load the file to the machine. Once the file is loaded, the user can confirm from the bottom right message box that the correct file is loaded. Once the file is loaded to the machine successfully, press the **Restart** button. The controller will re-boot with the new configuration and definition files for the machine.

Hit the **Refresh** Button available on bottom to refresh the list of available files.

Hit the **Cancel** Button to cancel this setting and exit the Model Setup menu.

4.7.1.2 Serial Number:

The **Serial Number** of the compressor will be entered in this location. This serial number is used in various places including the data logs for the machine. The serial number is set at the factory and can be used as a reference to the machine when needing information or replacement parts.

4.7.1.3 Design Pressure:

The **Design Pressure** setting is the pressure this machine is designed to run at. Figure 128 below shows the setting of **Design Pressure** set to *130 psi*. Note that setting the design pressure to a value that does not match the machine capabilities may allow dangerous operation of the compressor. The warning and fault pressure band settings will be limited based off the design pressure setting.

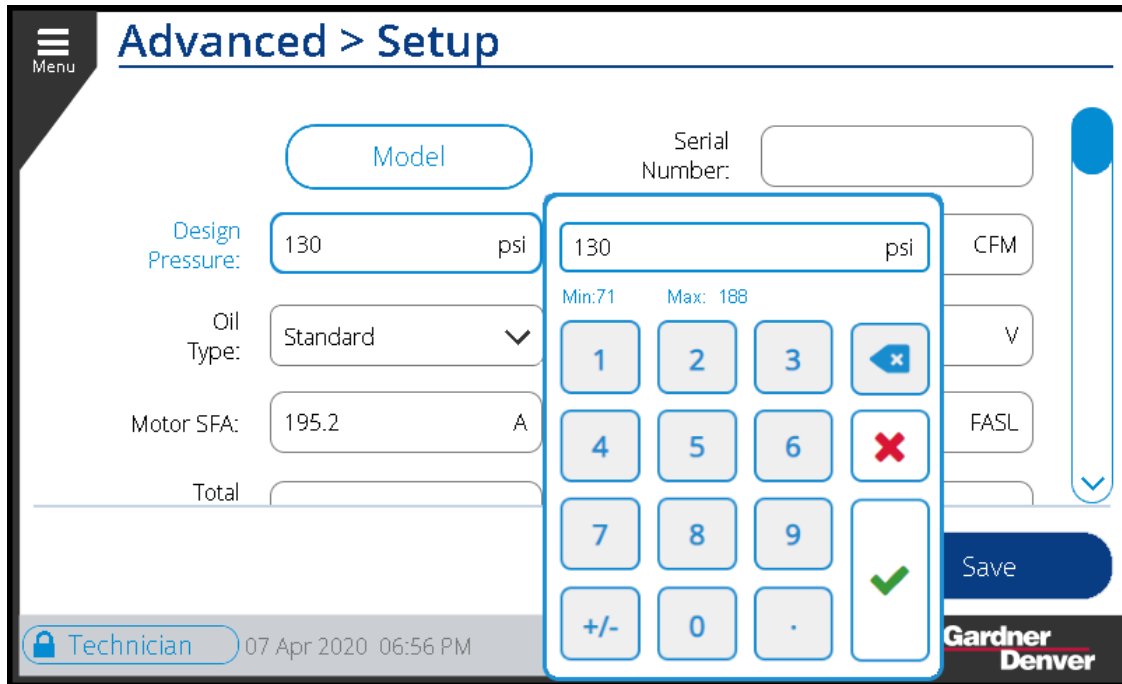

Figure 128: Design Pressure

4.7.1.4 Max Volume Flow:

The **Max Volume Flow** setting is used on fixed speed machines, it should be set to the compressor rated volume flow at the operating pressure. This value is used to calculate the current volume flow readings throughout the user interface as well as the volume flow used for some sequencing algorithms. Figure 129 below shows setting the **Max Volume Flow** to *281 CFM*.

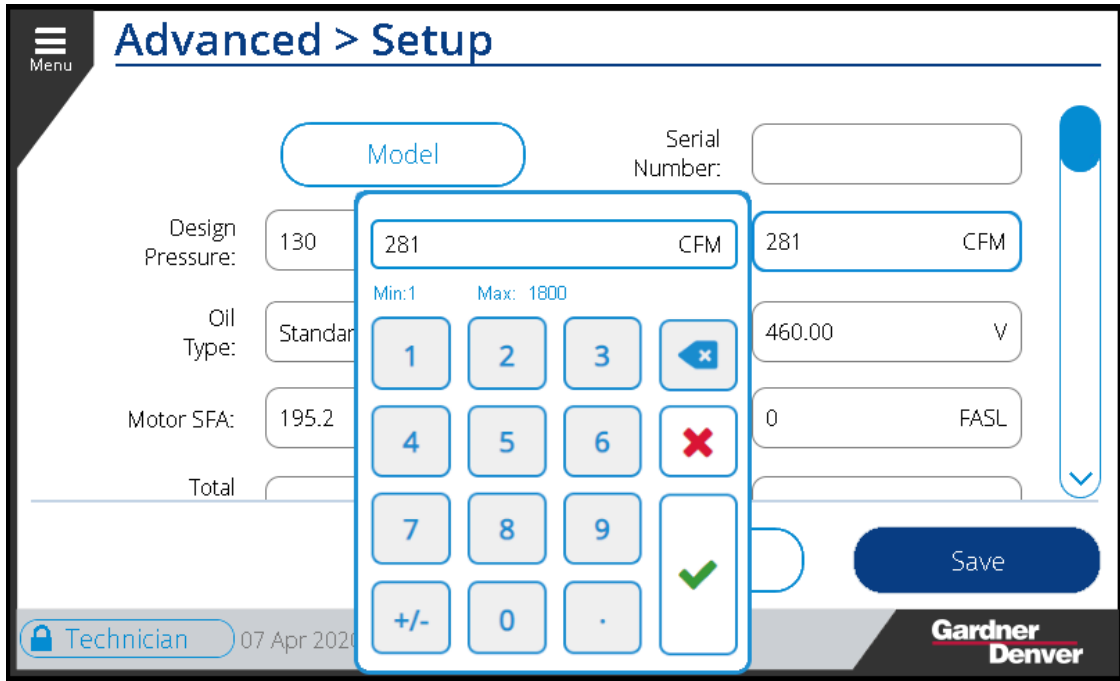

Figure 129: Max Volume Flow

4.7.1.5 Oil Type:

The **Oil Type** setting is used to specify the oil used in the compressor. There are two types of selections available: *Standard* and *High Temp*. This should be set to match the type of oil used in the machine. Figure 130 shows the drop down menu of **Oil Type**.

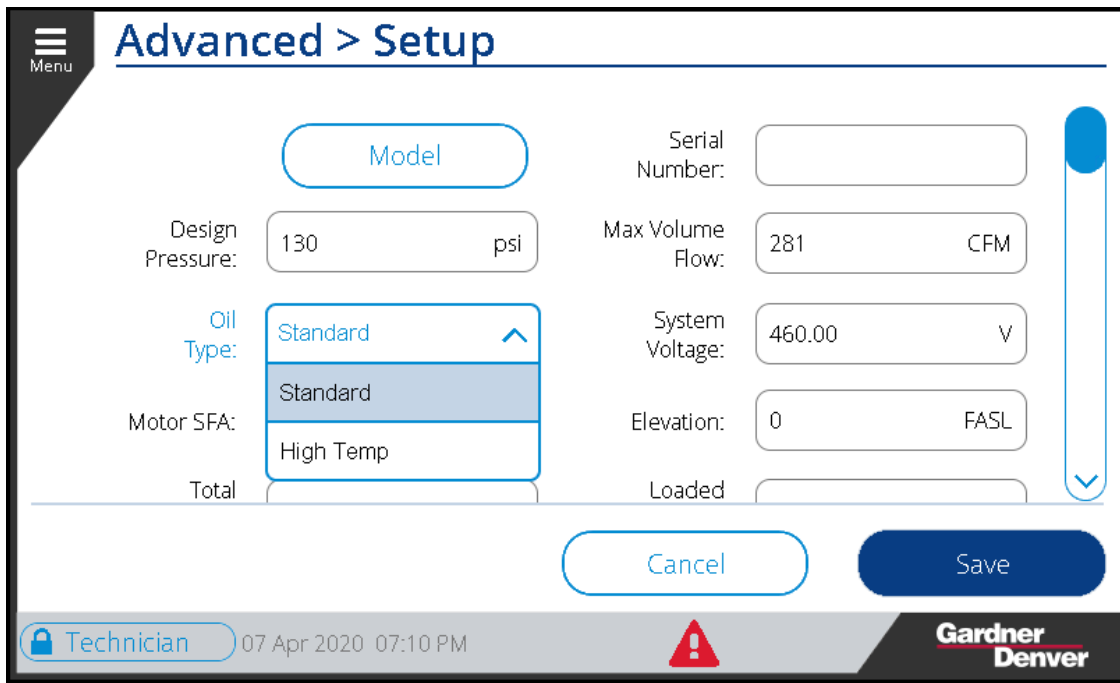

Figure 130: Oil Type

Each of the **Oil Types** use a specific aging algorithm to determine the oil change interval. The multipliers for the oil aging can be seen in Table 43 below. The **Oil Type** selections are the following:

Standard: Oil Change Timer counts down normally at high temperature. Use with AEON

9000SP or similar lubricant.

High Temp: Oil Change Timer counts down more slowly at high temperature. Use with AEON 9000TH or similar lubricant.

Table 43: Oil Change Multipliers

Oil Change Multipliers		
Oil Aging Clock Multiplier	Standard Oil Temperature Break Points	High Temp Oil Temperature Break Points
X1	< 180°F (82°C)	< 210°F (99°C)
X 1.3	180°F - 189°F (82°C - 87°C)	210°F - 219°F (99°C - 104°C)
X 2	190°F - 198°F (88°C - 92°C)	220°F - 228°F (104°C - 109°C)
X 4	199°F - 216°F (93°C - 102°C)	> 229°F (109°C)
X 8	217°F - 234°F (103°C - 112°C)	
X 16	> 234°F (112°C)	

4.7.1.6 System Voltage:

Each system is designed to operate at a certain voltage and in some cases a range of voltages. The User can configure the operating voltage by touching the voltage value and enter the **System Voltage** on the number-pad. Figure 131 below shows setting the **System Voltage** to 460V.

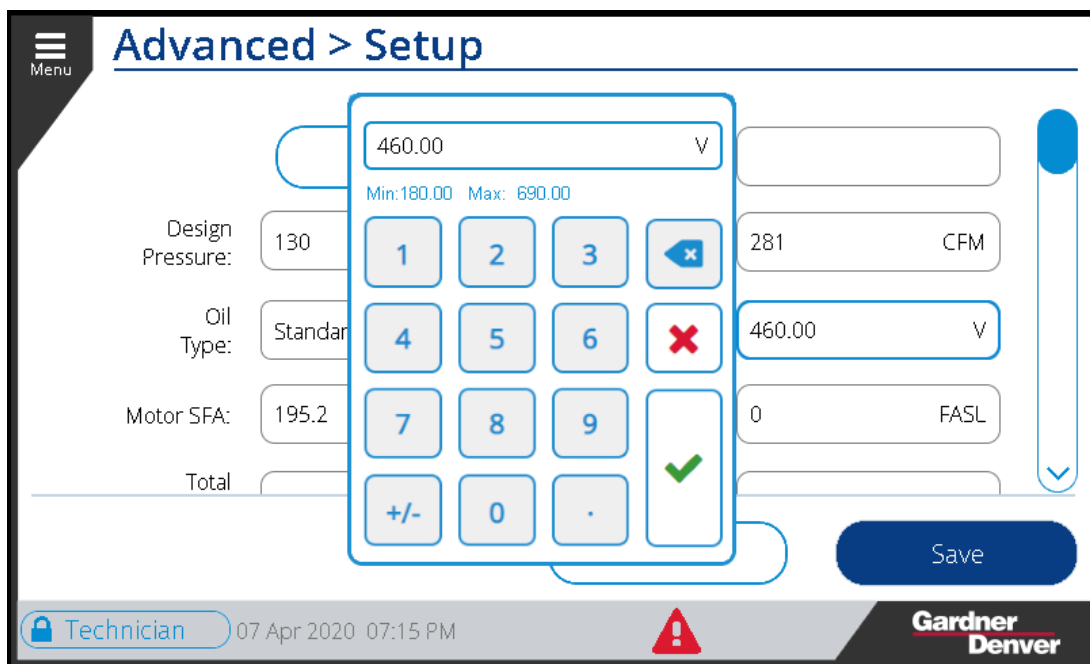

Figure 131: System Voltage

4.7.1.7 Motor SFA:

The **Motor Service Factor Amperage** value is the amount of current the motor will draw when running at the full service factor. This value can be obtained from motor manufacturer of the motor used in the system or listed on the motor nameplate. Figure 132 shows setting the value of **Motor SFA** as 195.2 A. This value is used on fixed speed machines where a motor current analog input is present.

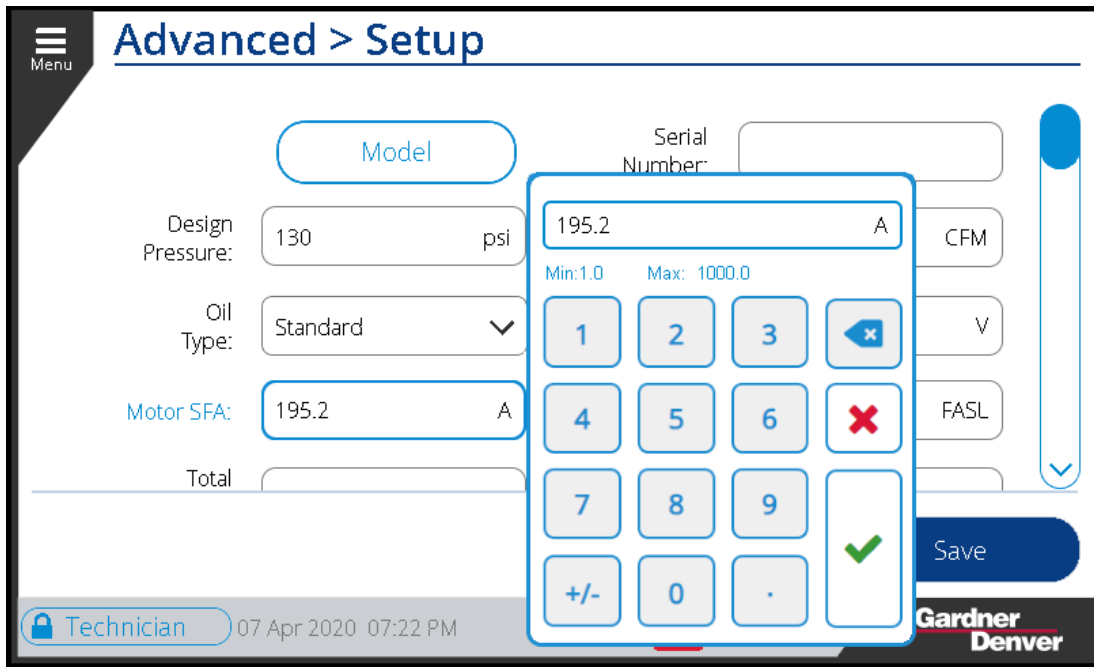

Figure 132: Motor SFA

4.7.1.8 Elevation:

The **Elevation** setting is the height above sea level of the geographical location where this unit (compressor/motor) is installed. Figure 133 below shows the **Elevation** setting. This value is used on variable speed machines to ensure that the variable speed drive performance is de-rated according to the elevation.

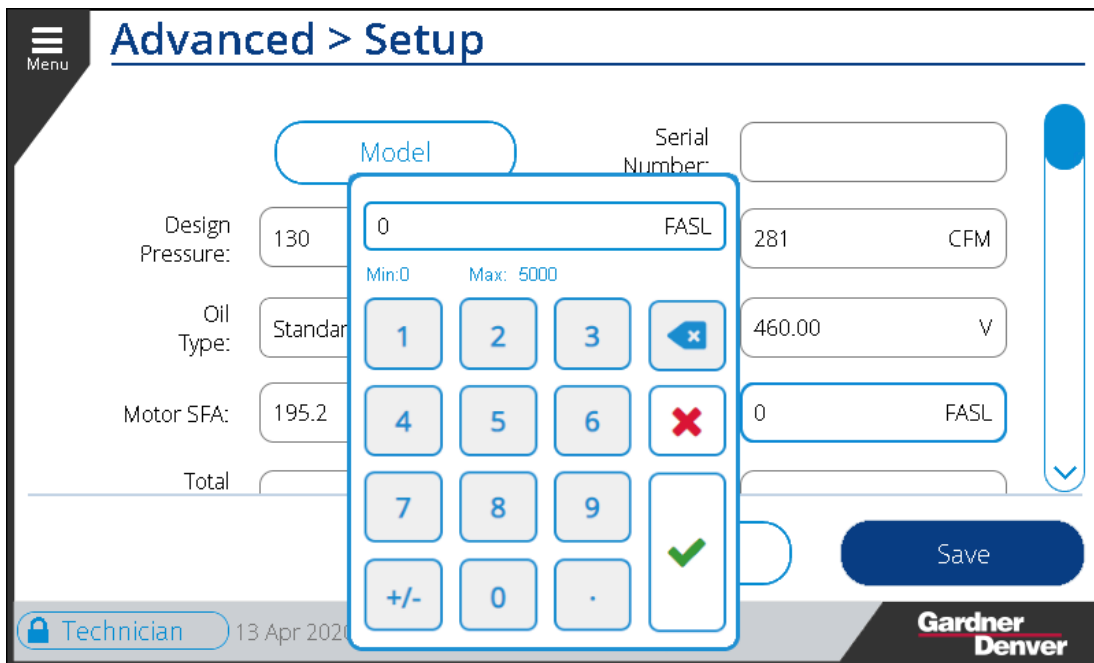

Figure 133: Elevation

4.7.1.9 Total Hours:

The **Total Hours** is the amount of run hours for the machine including both loaded and unloaded operation. The total hours must be set to match the actual hours on the machine when installing a replacement controller. Figure 134 shows setting the **Total Hours** to 100h.

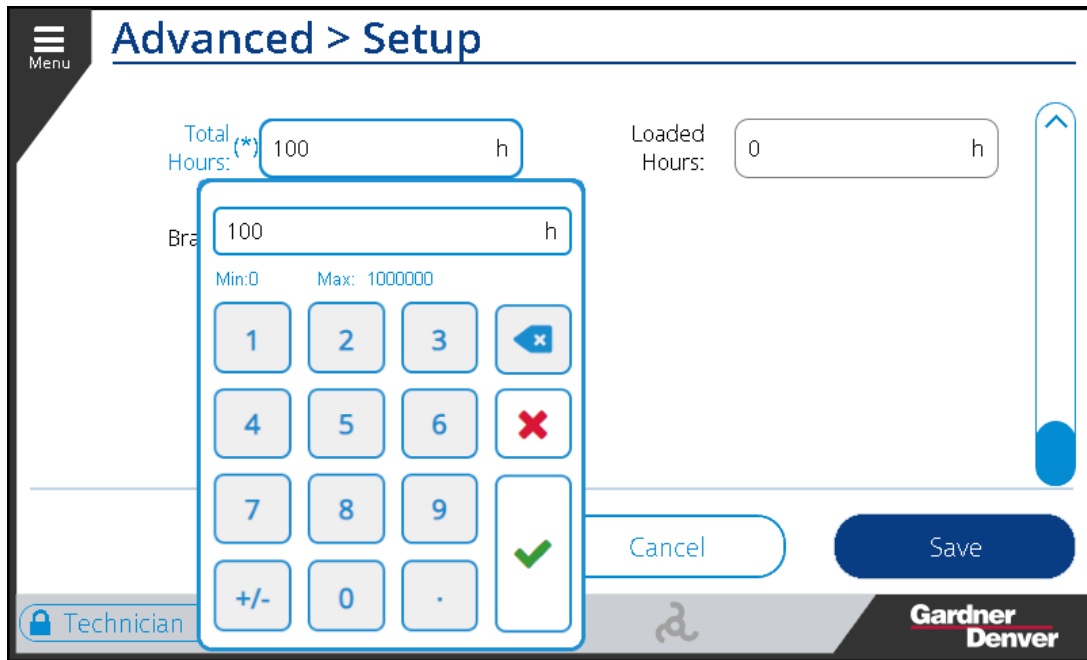

Figure 134: Total Hours

4.7.1.10 Loaded Hours:

The **Loaded Hours** are the hours run hours during which the machine was loaded and producing air. One thing to note, the **Loaded Hours** maximum allowed value will be equal to **Total Hours**. As shown in Figure 135. The loaded hours must be set to match the actual loaded hours on the machine when installing a replacement controller.

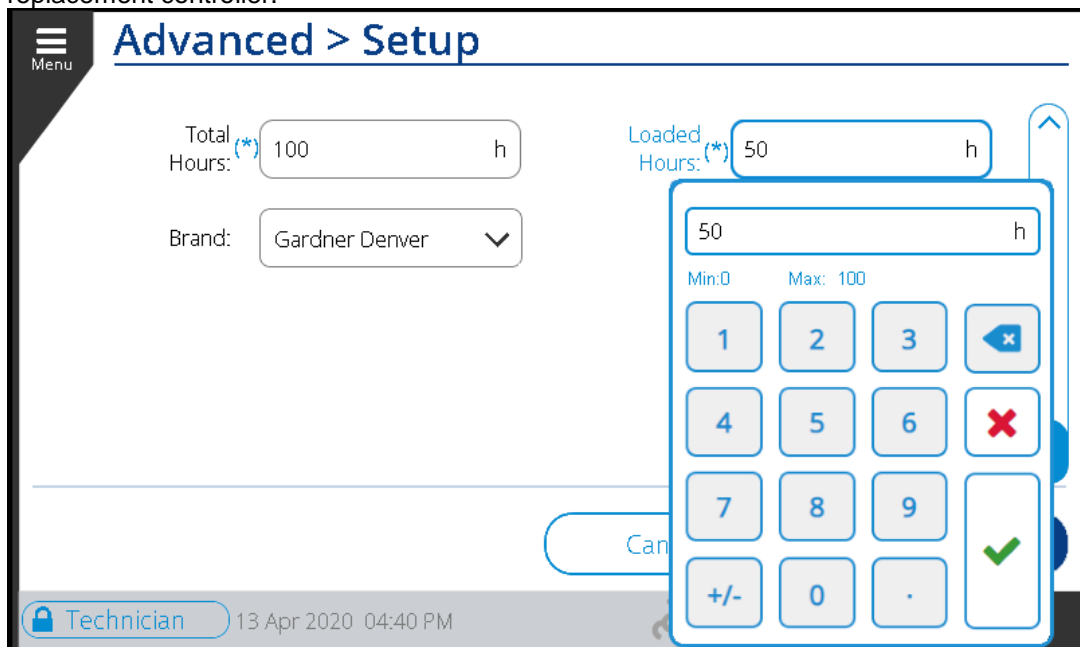

Figure 135: Loaded Hours

4.7.1.11 Brand:

The **Brand** Name can be set to *Gardner Denver* or *CompAir* as seen in the example below. Use the drop down menu to select and set it accordingly. Figure 136 below shows the drop down menu for the **Brand** setting. Note that the brand may only be set once by the technician level access and then only changed by the factory level thereafter.

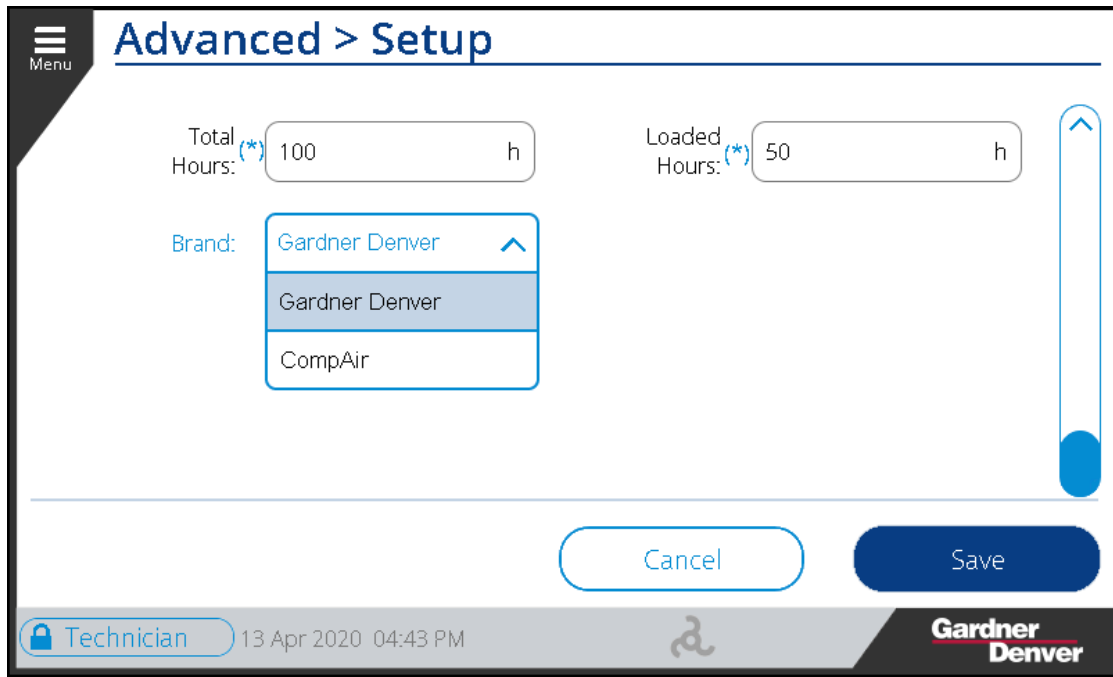

Figure 136: Brand

4.7.2 Operating Limits:

On the advanced **Operating Limits** menu the user can set the machine operating pressures and temperatures warning and fault set points. This option is available only to Technician and Factory level logins. Figure 137 below represents the **Operating Limits** Home Page.

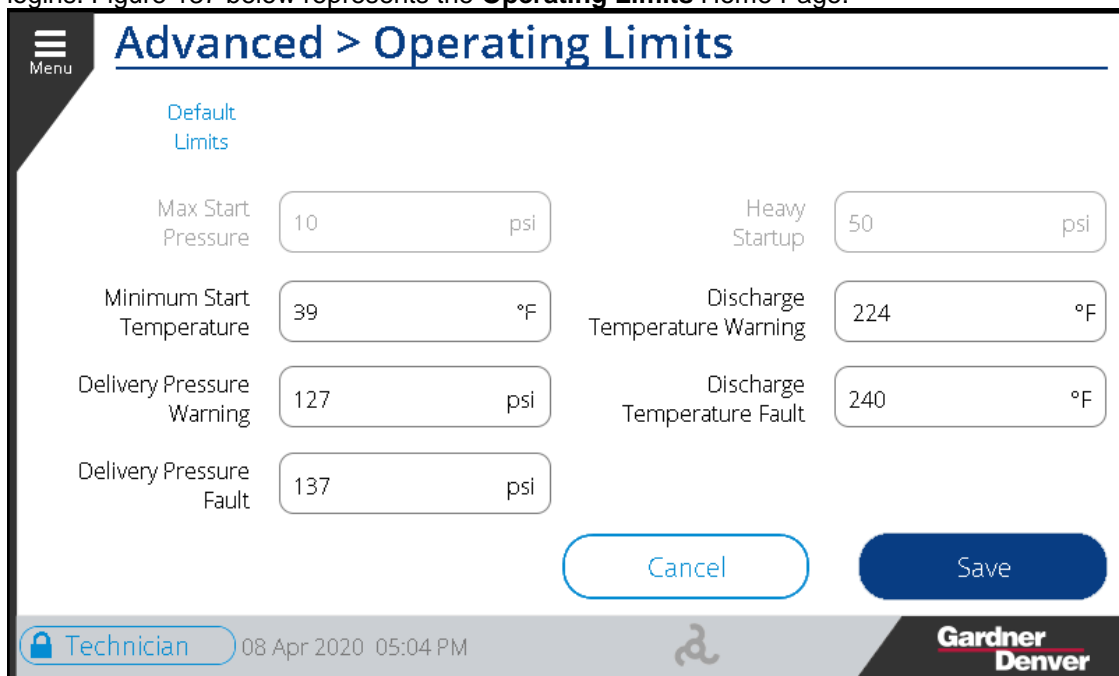

Figure 137: Operating Limits

As shown in the Figure above, **Max Start Pressure** and **Heavy Startup** settings are grayed out and the user can't make changes to them.

4.7.2.1 Max Start Pressure:

The **Max Start Pressure** setting defines the maximum start pressure in the reservoir before the motor will be allowed to start.

4.7.2.2 Heavy Startup:

The **Heavy Startup** setting defines the maximum pressure that will be allowed to be built up in the reservoir during the acceleration process, if this pressure is exceeded a heavy startup fault will occur.

4.7.2.3 Minimum Start Temperature:

The **Minimum Start Temperature** setting is the temperature the compressor needs to be at before the motor will start. Figure 138 below shows the setting of **Minimum Start Temperature** as 39°F.

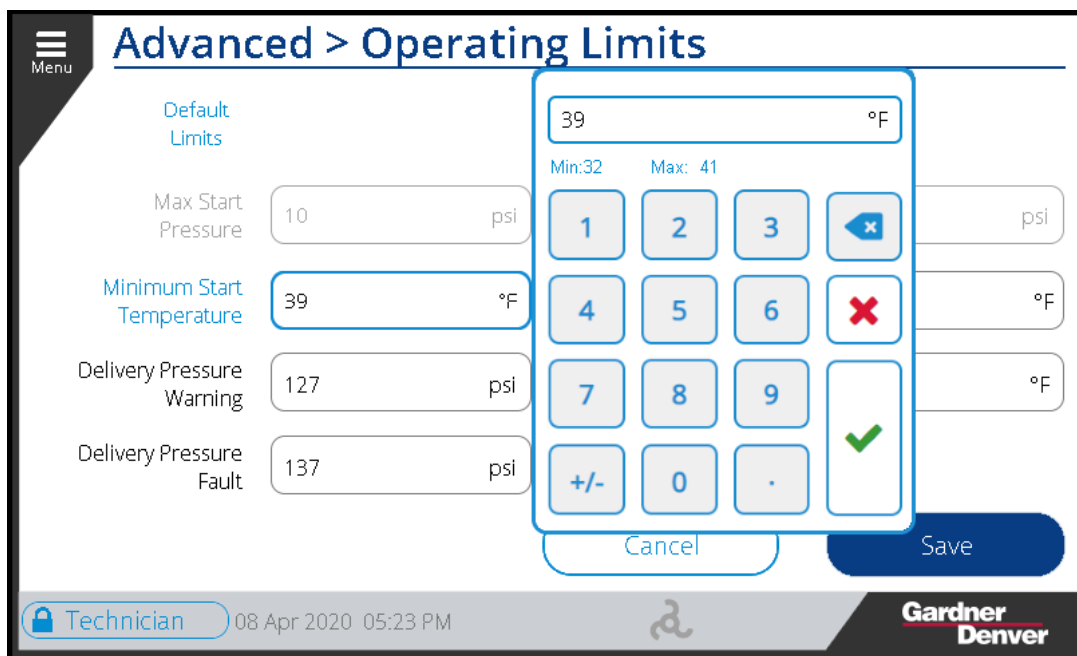

Figure 138: Minimum Start Temperature

4.7.2.4 Discharge Temperature Warning:

The **Discharge Temperature Warning** setting defines the temperature value where an over temperature warning will be triggered. This applies to both the discharge and separator temperature values. The warning may not be set above the value of the discharge temperature fault. Figure 139 below shows the setting of **Discharge Temperature Warning** at 224°F.

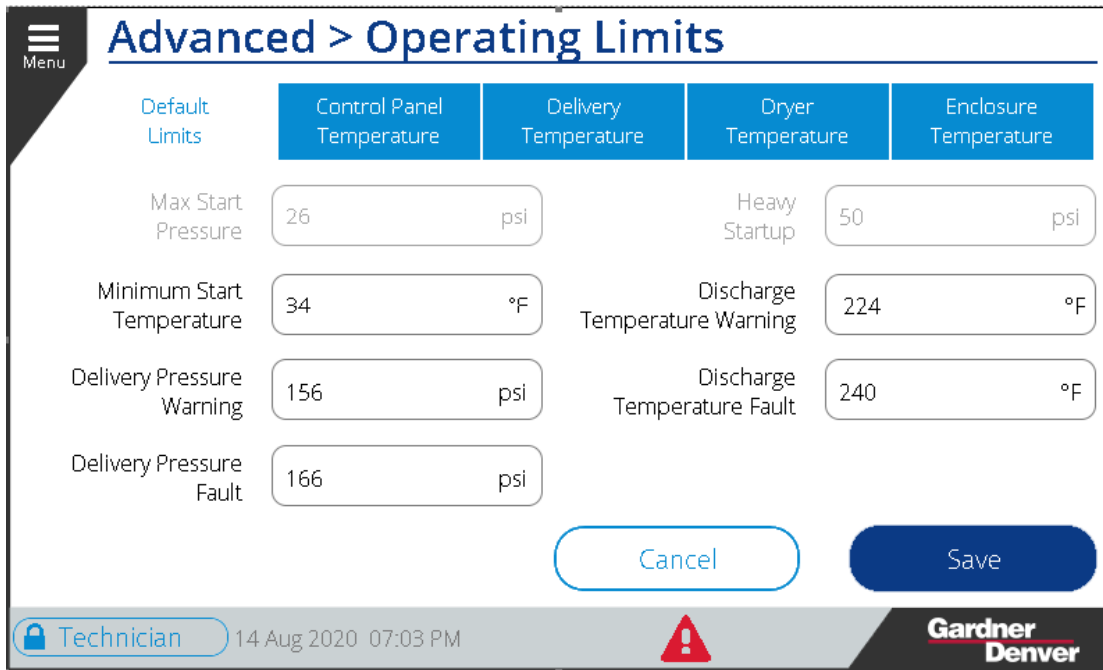

Figure 139: Discharge Temperature Warning

4.7.2.5 Discharge Temperature Fault:

The **Discharge Temperature Fault** setting defines the temperature where an over temperature fault will be triggered in the controller. The technician may set the value of the **Discharge Temperature Fault** lower than the factory default but not above. Figure 140 below shows the setting of **Discharge Temperature Fault** as 240°F.

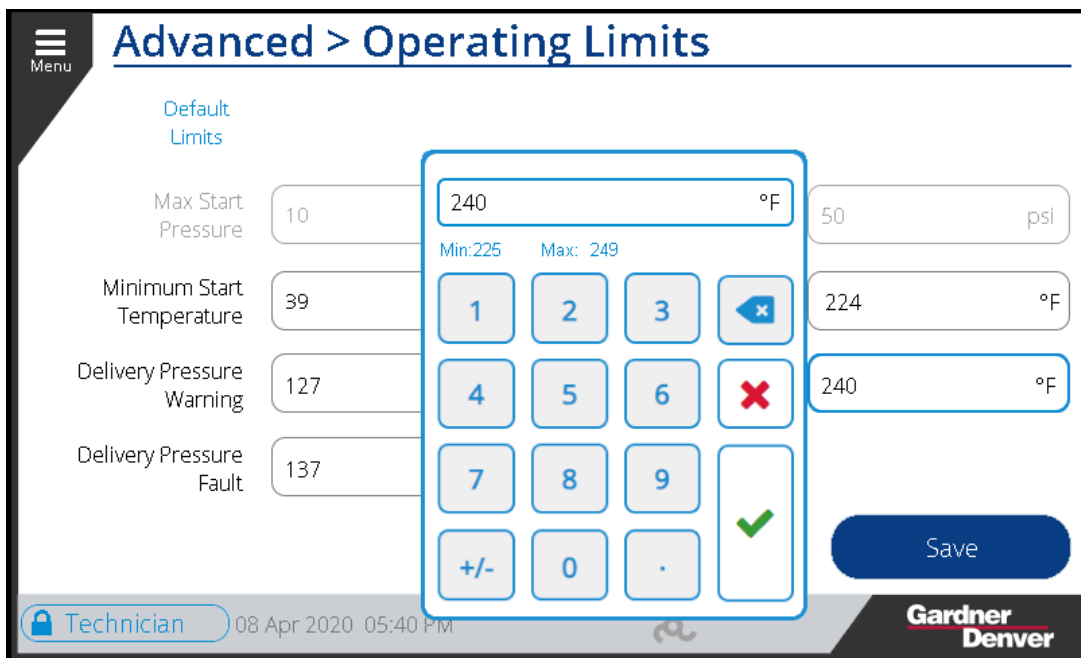

Figure 140: Discharge Temperature Fault

4.7.2.6 Delivery Pressure Warning:

The **Delivery Pressure Warning** setting defines the pressure where an over pressure warning is triggered in the controller. Figure 141 below shows setting the **Delivery Pressure Warning** to 127 *psi*.

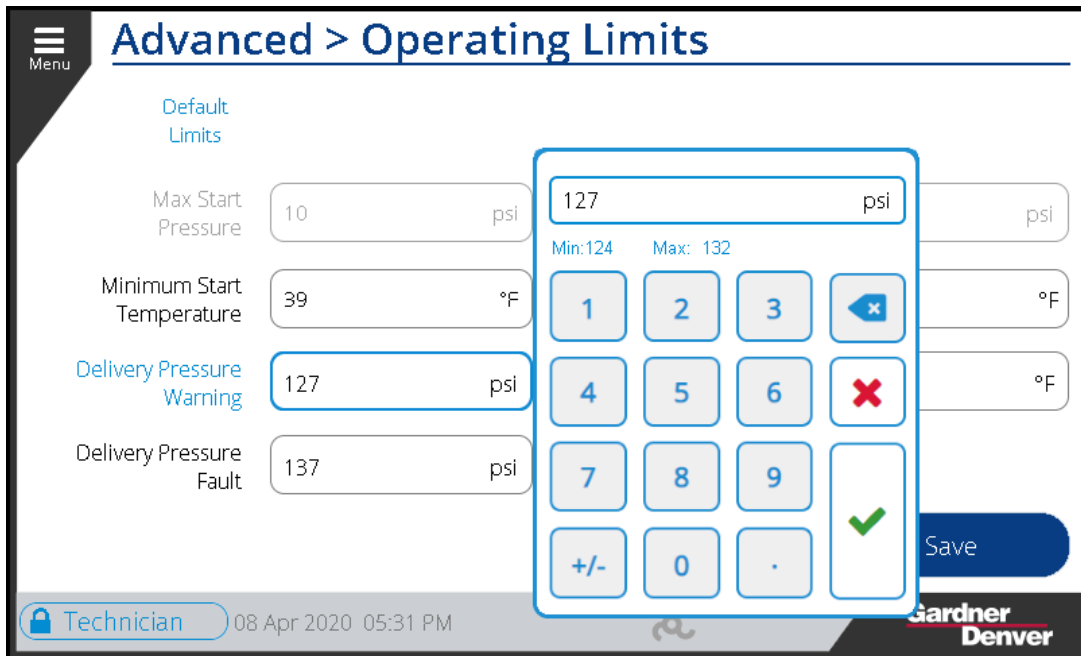

Figure 141: Delivery Pressure Warning

4.7.2.7 Delivery Pressure Fault:

The **Delivery Pressure Fault** defines the pressure where an over pressure fault is triggered in the controller. Figure 142 below shows setting the **Delivery Pressure Fault** to 137 *psi*.

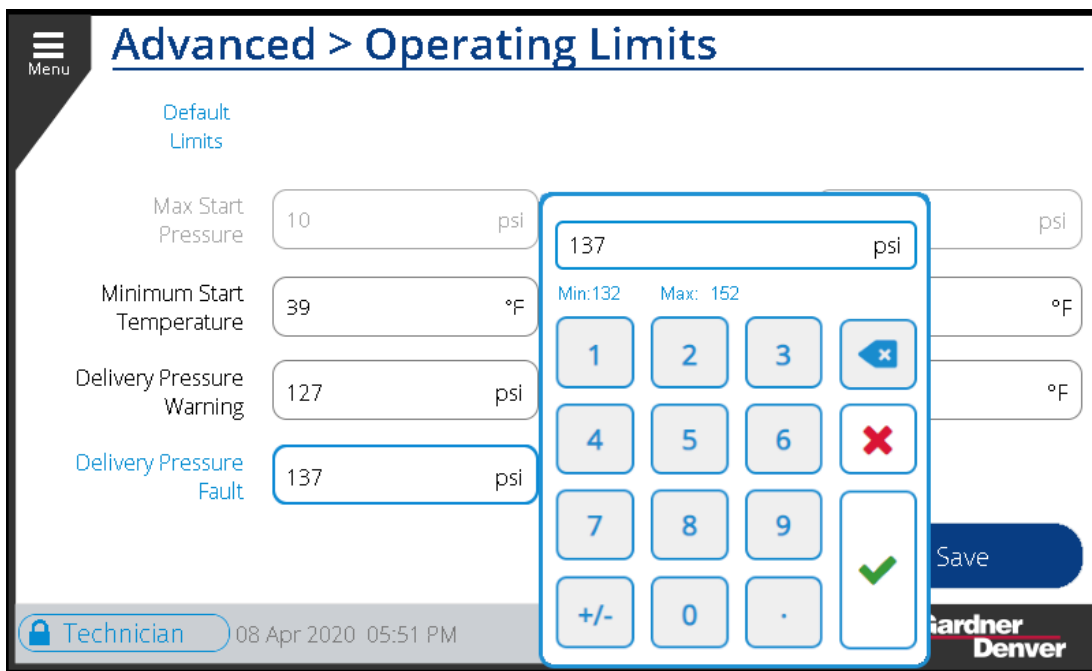

Figure 142: Delivery Pressure fault

4.7.2.8 Additional Operating Limits

When the *Temperature Inputs* on the **Programmable IO** screen are set to a channel, additional operating limit tabs will show next to the **Default Limits** on the **Operating Limits** screen. The possible tabs are *Control Panel Temperature*, *Delivery Temp*, *Dryer Temp*, and *Enclosure Temp* and they will only show up when they are addressed to a channel.

Under each of these tabs the user can set *warning* and *fault* limits for each of the additional temperature sensors on the machine. There are min and max values for each entry as explained previously for the other settings. An example of the *Enclosure Temperature* tab settings and the other possible tabs are shown below in Figure 143.

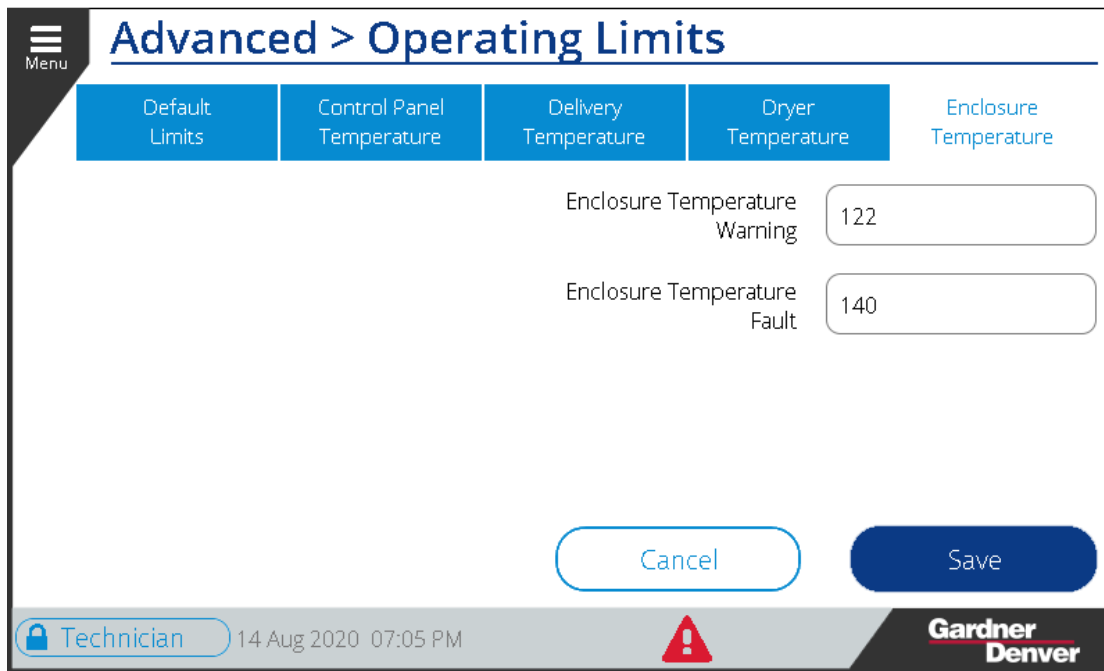

Figure 143: Enclosure Temperature Limits

4.7.3 Control - Default:

The **Control** settings are mainly related to compressor/motor operation. Figure 144 below shows the home screen for **Control** settings under the advanced settings menu. These are the settings in the *Default* tab.

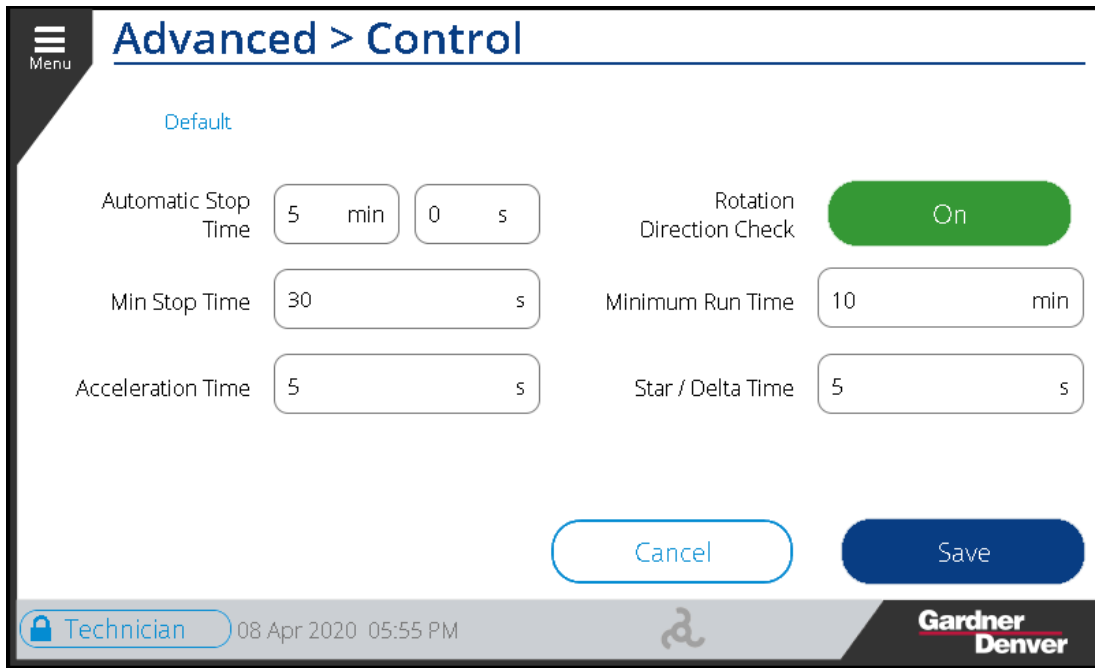

Figure 144: Control - Default

4.7.3.1 Automatic Stop Time:

The **Automatic Stop Time** is the amount of time that the compressor will run after the blowdown timer has expired before stopping the motor. This time setting has two inputs, one is for Minute and other for Seconds. Figure 145 below shows the setting **Automatic Stop Time** to 5 min 0 Sec.

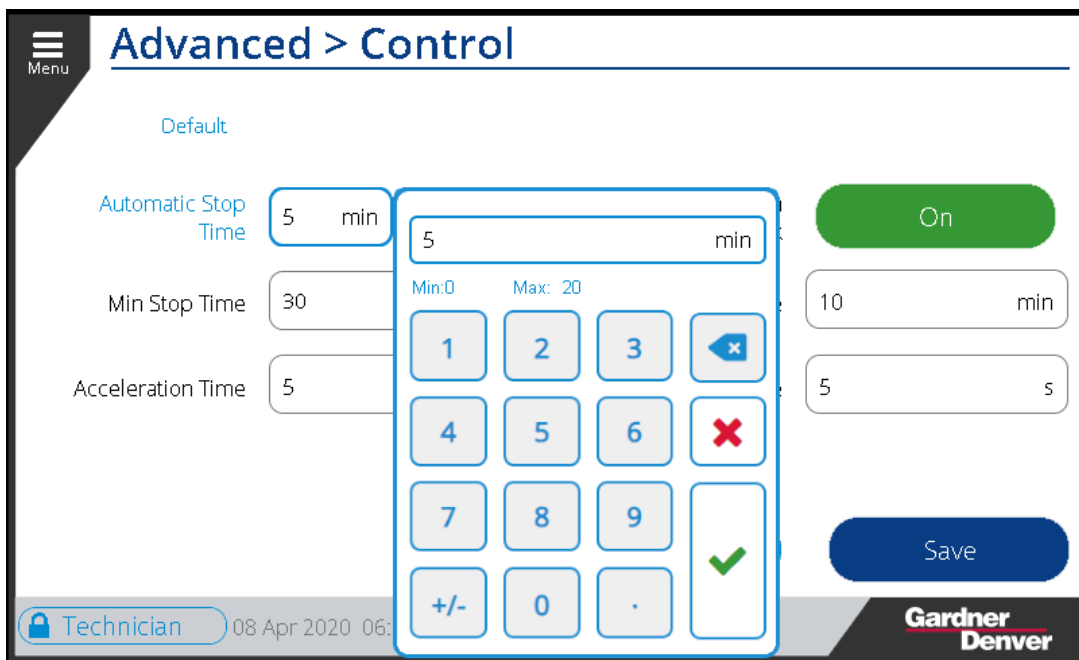

Figure 145: Automatic Stop Time

4.7.3.2 Rotation Direction Check:

The **Rotation Direction Check** setting can be set to either *On* or *Off* by using the On/Off toggle Button. When the **Rotation Direction Check** is enabled, the controller will for pressure to be built in the reservoir immediately following the motor starting, if adequate pressure is not detected the unit will be shut down on a no start pressure fault. This may indicate that the motor is turning the wrong direction. In some

installations, such as high elevation, it may be necessary to turn this function off to avoid trips. Figure 146 shows the **Rotation Direction Check** setting turned *On*.

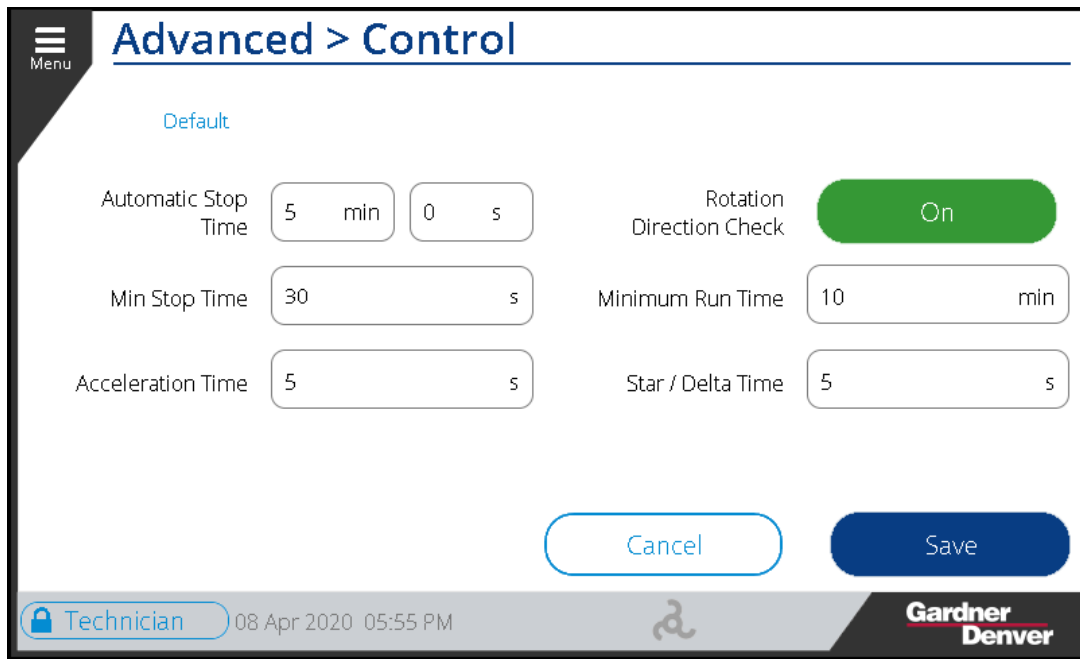

Figure 146: Rotation Direction Check

4.7.3.3 Min Stop Time:

The **Min Stop Time** is the minimum amount of time that the compressor motor will run after pressing the stop button, which starts the depressurization process. Figure 147 shows setting the **Minimum Stop Time** as *30 seconds*.

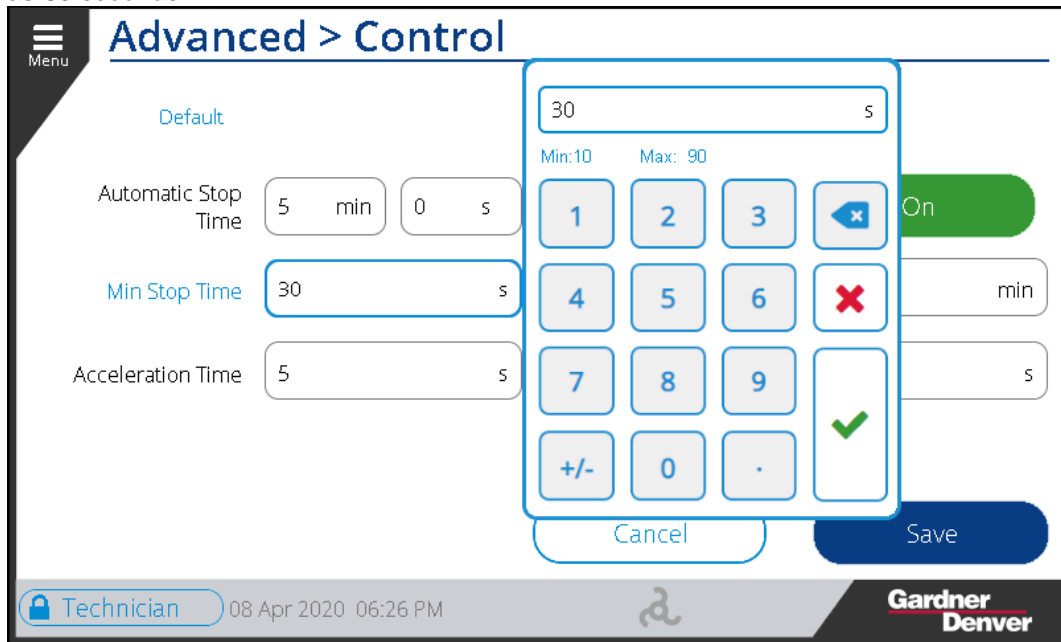

Figure 147: Min Stop Time

4.7.3.4 Minimum Run Time:

The **Minimum Run Time** setting is defines the amount of time that the compressor must be running before it will be allowed to stop automatically. This setting should be utilized to limit the number of motor starts per

hour, without unnecessarily extending the automatic stop time. The range can be set from 1 Minute to 60 Minutes. Figure 148 shows the setting of **Minimum Run Time** to 10 Mins.

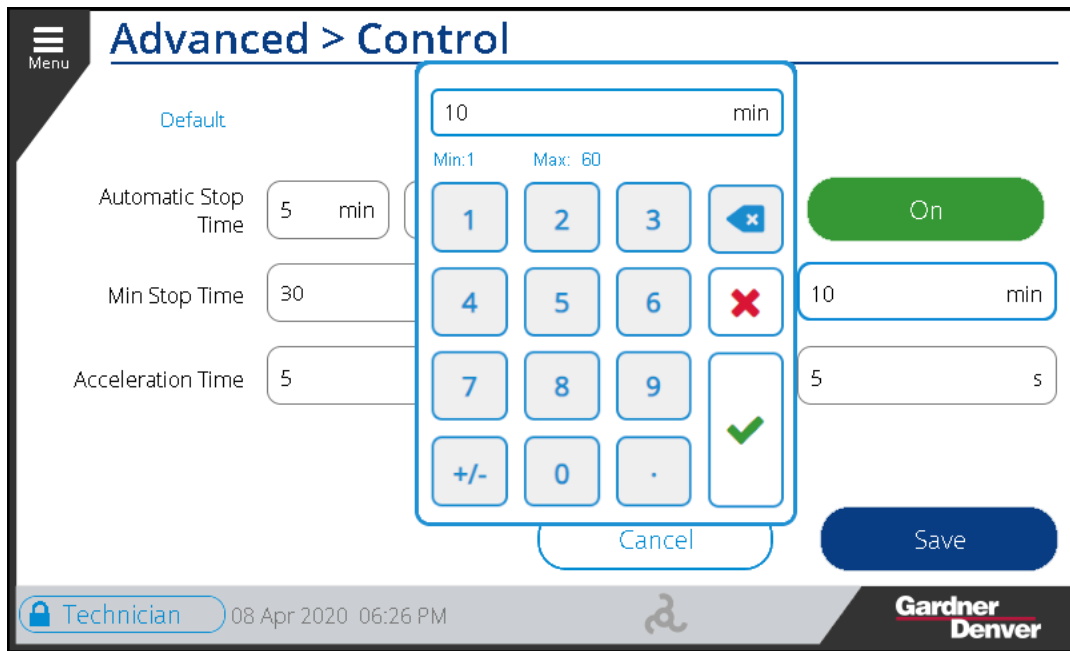

Figure 148: Minimum Run Time

4.7.3.5 Acceleration Time:

The **Acceleration Time** setting is used on fixed speed machines and defines the amount of time that the motor takes to accelerate. Setting a proper Acceleration time reduces risk of Compressor/Motor failure as it provides a smooth loading of the Compressor. On machines with a wye-delta starter the acceleration time will start after the wye-delta transition. To extend the time before the compressor is loaded after the wye-delta transition, set the acceleration time to the desired value. On machines with a full voltage, soft starter, or remote starter, the acceleration time will start after the main motor has been started and should be set to a time sufficient to allow the main motor to accelerate to full speed before loading the compressor. Figure 149 shows the setting the **Acceleration Time** to 5s.

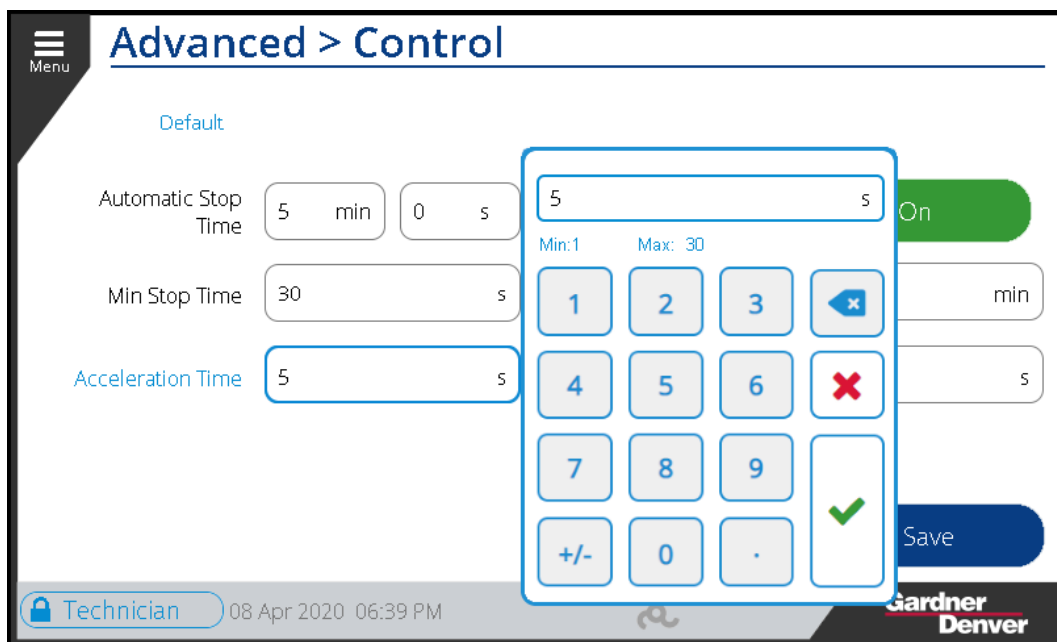

Figure 149: Acceleration Time

4.7.3.6 Star Delta Time:

The **Star Delta Time** setting defines the amount of time the main motor will run in the wye phase before transitioning to the delta connection. This value should be set to an appropriate value for the compressor by default but may be adjusted, if needed. The time should be set to a sufficient value to allow the main motor to accelerate to full speed before transitioning to delta. Figure 150 show the setting of **Star Delta Time** to 5 Seconds.

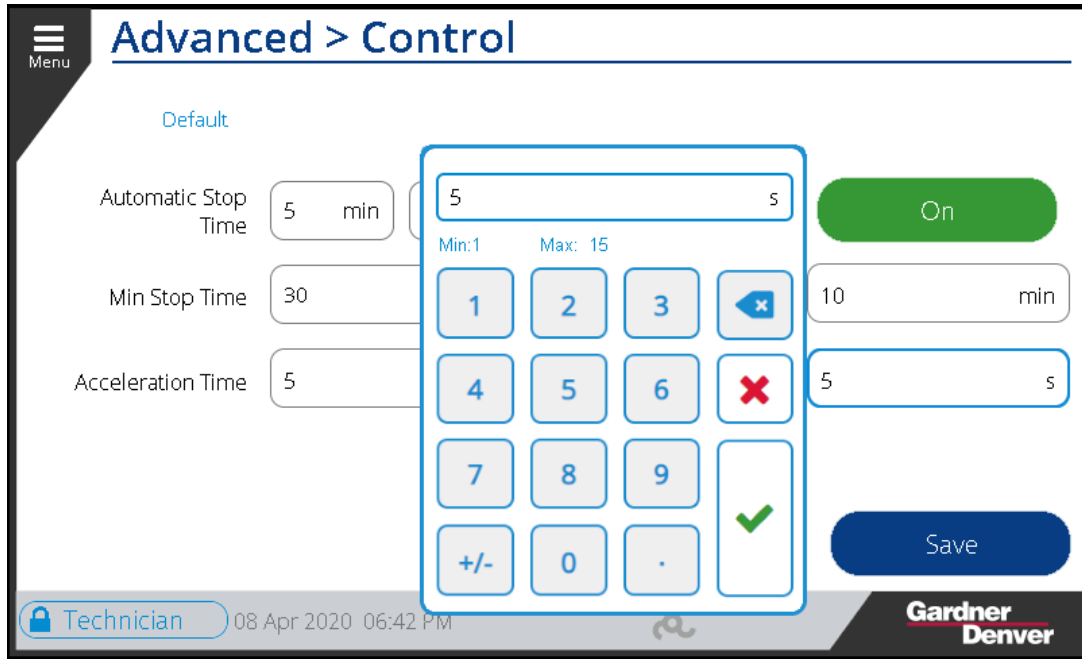

Figure 150: Star Delta Time

4.7.4 Control – Variable Speed:

The **Control – Variable Speed** settings are related to the operation of the variable frequency drive on compressor packages that have a VFD. Figure 151 below shows the home screen for **Control – Variable Speed** settings under the advanced settings menu. These are the settings in the *Variable Speed* tab and this tab will only show on certain machine configurations.

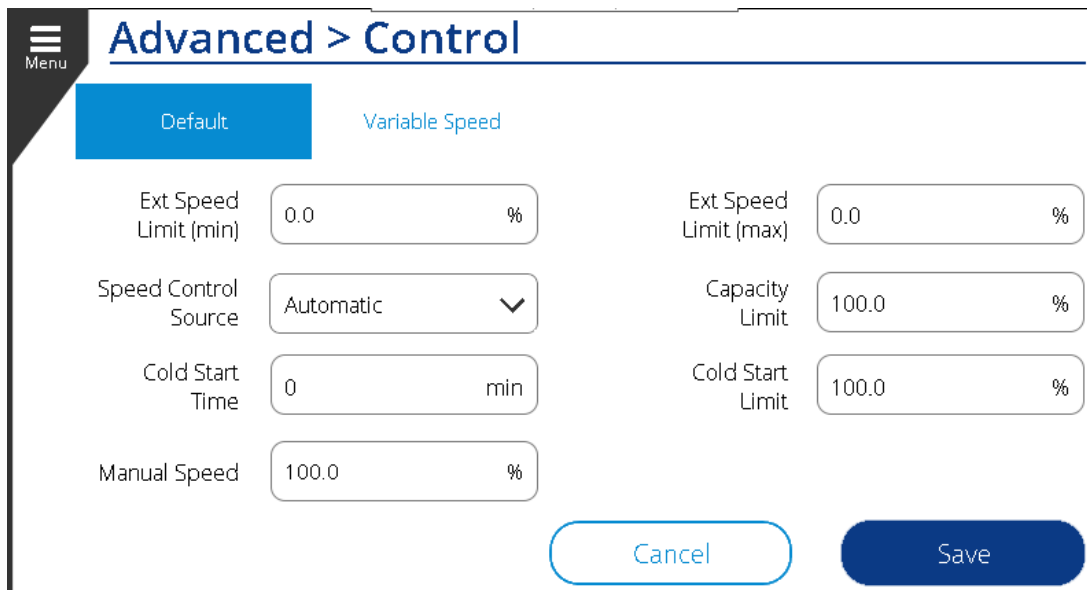

Figure 151: Control - Variable Speed

4.7.4.1 Ext Speed Limit (min):

The **Ext Speed Limit (min)** is a percentage of the minimum speed of the variable speed motor. This is used to set the minimum speed limit when the programmable digital input function for External Speed Limit is active. This can only be used to increase the minimum speed above the allowable minimum speed for the machine for a given operating point. For example, if the allowable minimum speed is 21% for a given machine at the current pressure and the Ext Sped Limit (min) is set to 30%, the machine would not be allowed to modulate the speed below 30% when the External Speed Limit input was active. If the Ext Speed Limit (min) is set to 15% on this same machine, the machine would still not be allowed to run below its minimum of 21% regardless of the state of the input.

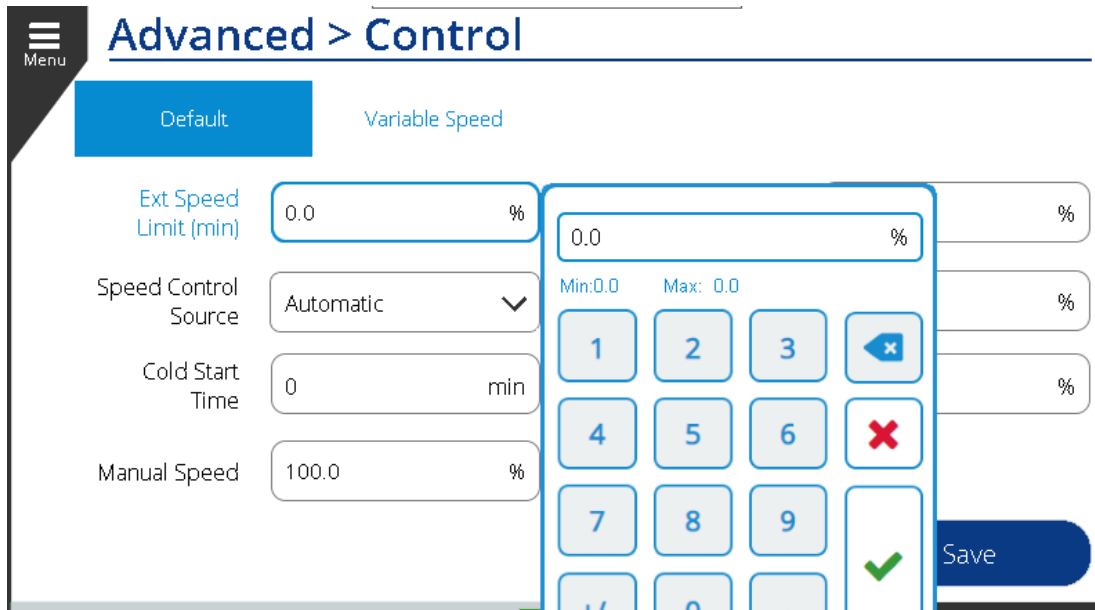

Figure 152: Ext Speed Limit (min)

4.7.4.2 Ext Speed Limit (max):

The **Ext Speed Limit (max)** is a percentage of the maximum speed of the variable speed motor. This setting is used to set the maximum speed limit when the programmable digital input function for External Speed Limit is active> This can only be used to decrease the maximum speed above the allowable maximum speed for the machine for a given operating point.

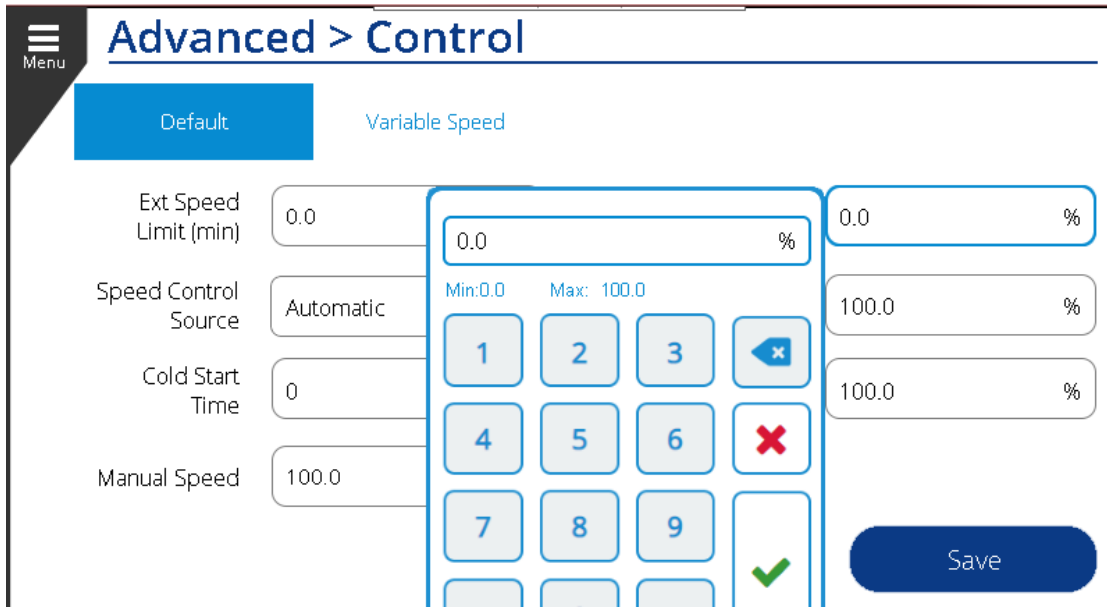

Figure 153: Ext Speed Limit (max)

4.7.4.3 Speed Control Source:

The **Speed Control Source** is a selection drop-down to specify the source of the VFD's speed control input. The user can select between *Automatic*, *Remote*, and *Manual*, shown below in Figure 154. When the Speed Control Source is set to Automatic (the default value), the controller will use its internal algorithms based on the system configuration to control the speed of the motor and attempt to maintain pressure control. When the speed control source is set to Remote, the analog input for Remote Speed Control will be used to control the speed of the motor between the allowable minimum and maximum speeds for the current operating point. When the Speed Control Source is set to Manual, the Manual Speed setting will be used to control the speed of the motor.

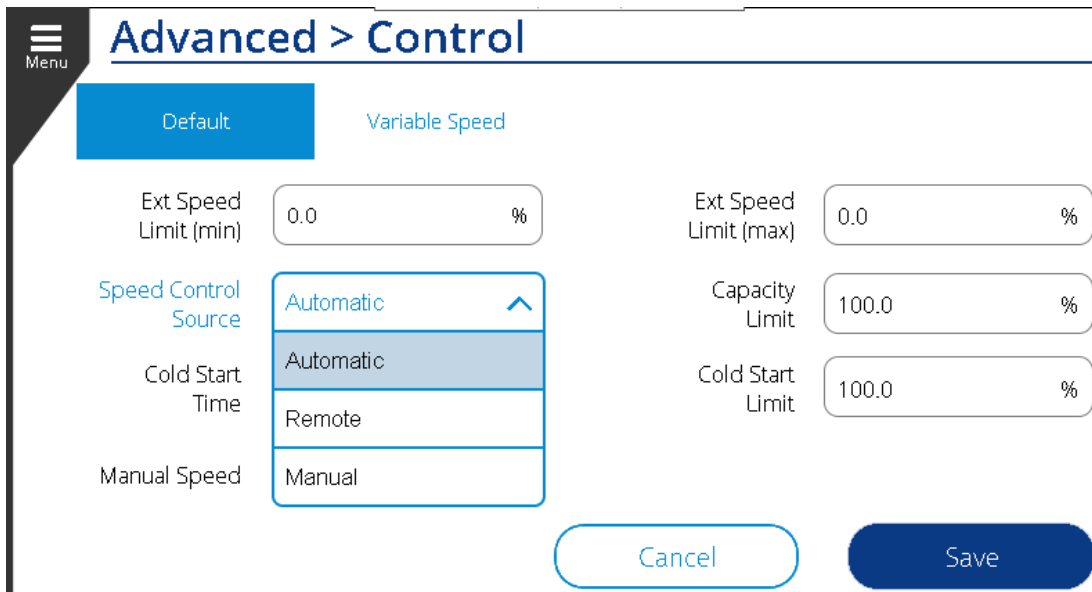

Figure 154: Speed Control Source

4.7.4.4 Capacity Limit:

The **Capacity Limit** setting is a percentage of the compressor's full speed. This setting limits the maximum speed that the compressor will run in any operating mode. Unlike the Ext Speed Limit settings, the Capacity Limit is active all of the time and a setting other than 100% will cause maximum speed limiting to occur any time that the motor is active. This setting may be used in cases where a temporary power limitation or other condition presents a need to limit the maximum power or flow of the machine.

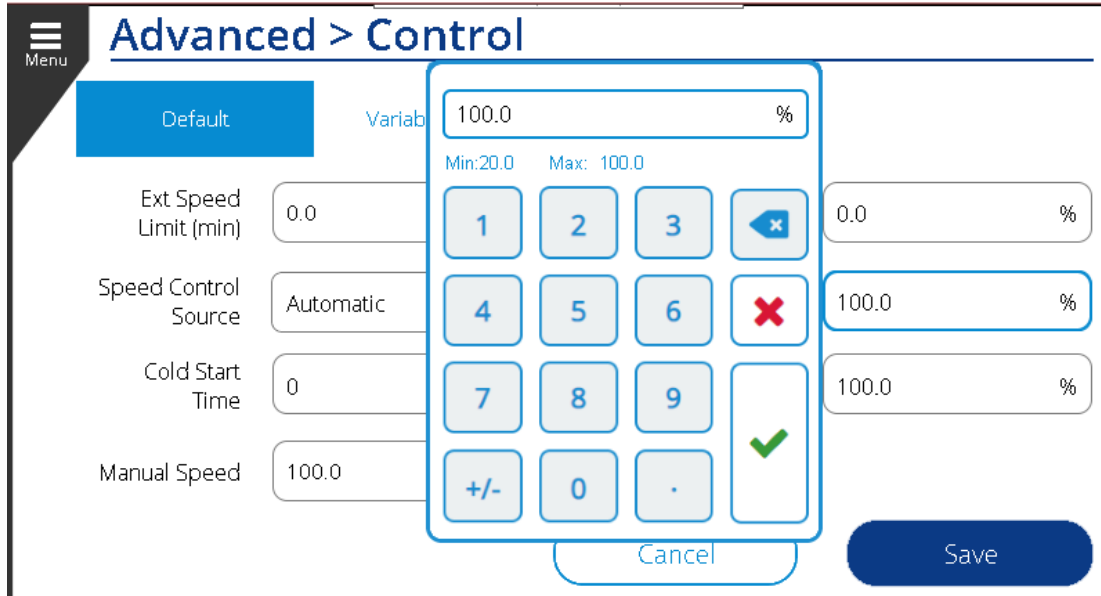

Figure 155: Capacity Limit

4.7.4.5 Cold Start Time:

The **Cold Start Time** setting allows the user to specify a time delay for the motor to warm up in cold weather before allowing to start and run fully loaded. This setting has a maximum time setting of 15 minutes, shown below in Figure 156. This is the time the compressor will run at a specified capacity when the inlet temp of the compressor reads less than 50 degrees Fahrenheit.

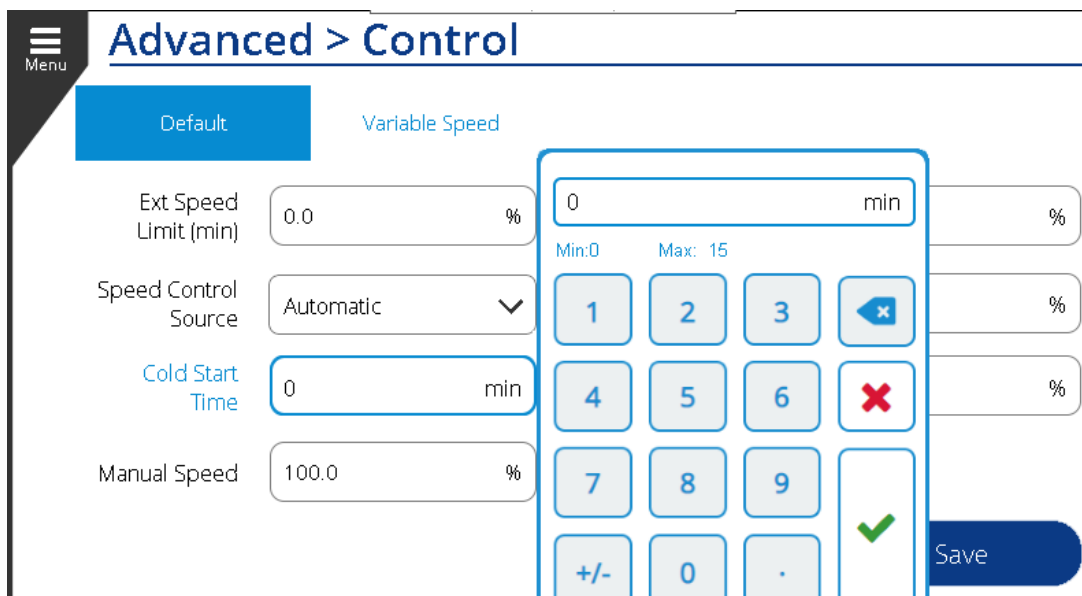

Figure 156: Cold Start Time

4.7.4.6 Cold Start Limit:

The **Cold Start Limit** setting is a percentage between 50% and 100%, which sets the limit of the compressor's full speed when running under cold start conditions, shown in Figure 157 below. This limit is active for the duration of the Cold Start Time setting when starting at ambient conditions less than 50 degrees Fahrenheit.

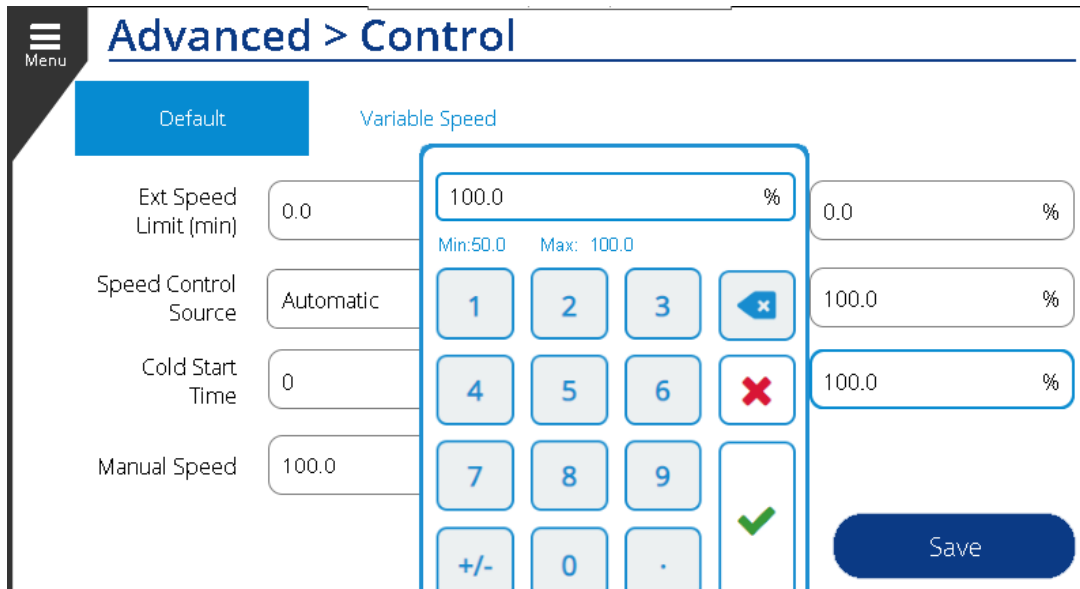

Figure 157: Cold Start Limit

4.7.4.7 Manual Speed:

The **Manual Speed** setting allows the user to manually set the speed of the VFD output to the motor based on a percentage of the full speed. This speed is active when the Speed Control Source is set to Manual. The compressor will still load and unload based on the operating settings of the machine, but the motor will run at a fixed speed rather than modulating the motor speed to achieve pressure control.

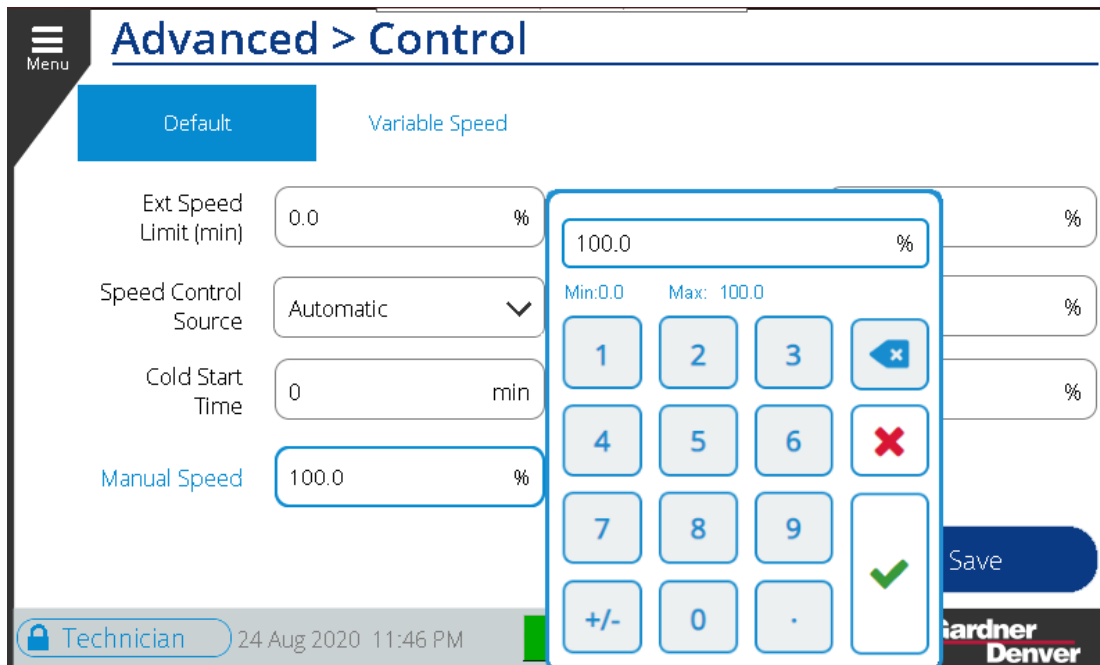

Figure 158: Manual Speed

4.7.5 Cooling - Default:

The Advanced **Cooling** menu has two settings, one is the selection of the **Cooling Type** and the second is the selection of the type of **Fan Control** being used on the machine. Figure 159 below represents the **Cooling** settings screen.

The screenshot shows the 'Advanced > Cooling' settings screen. The title bar includes a 'Menu' icon and the text 'Advanced > Cooling'. Below the title, the word 'Default' is displayed. There are three settings: 'Cooling Type' with a dropdown menu showing 'Air Cooled', 'Fan Control' with a dropdown menu showing 'Constant', and 'Fan Shutoff Delay' with a text input field containing '1' and a unit label 'min'. At the bottom of the screen, there are two buttons: 'Cancel' and 'Save'.

Figure 159: Cooling

4.7.5.1 Cooling Type:

There are two options to select for **Cooling Type**: *Air Cooled* and *Water Cooled*. Before making any change to this parameter, one should know what cooling type the machine uses, this value should generally not be changed in the field. Figure 160 below shows the selection between *Air Cooled* and *Water Cooled* from drop down menu.

The screenshot shows the 'Advanced > Cooling' settings screen with the 'Cooling Type' dropdown menu open. The menu lists 'Air Cooled' (which is highlighted) and 'Water Cooled'. The other settings, 'Fan Control' set to 'Constant' and 'Fan Shutoff Delay' set to '1 min', and the 'Cancel' and 'Save' buttons at the bottom, are the same as in Figure 159.

Figure 160: Cooling Type

4.7.5.2 Fan Control:

There are two fan control types: *Constant* and *Thermostatic*. Figure 161 below shows the **Fan Control** setting selection drop down menu.

Constant: Under this setting the cooling fan will run continuously anytime the main motor of the machine is running.

Thermostatic: This setting runs the cooling fan based on thermal sensor feedback. If the temperature goes up beyond a set limit then the controller will turn on the cooling fan and will turn off if the temperature goes below the set limit.

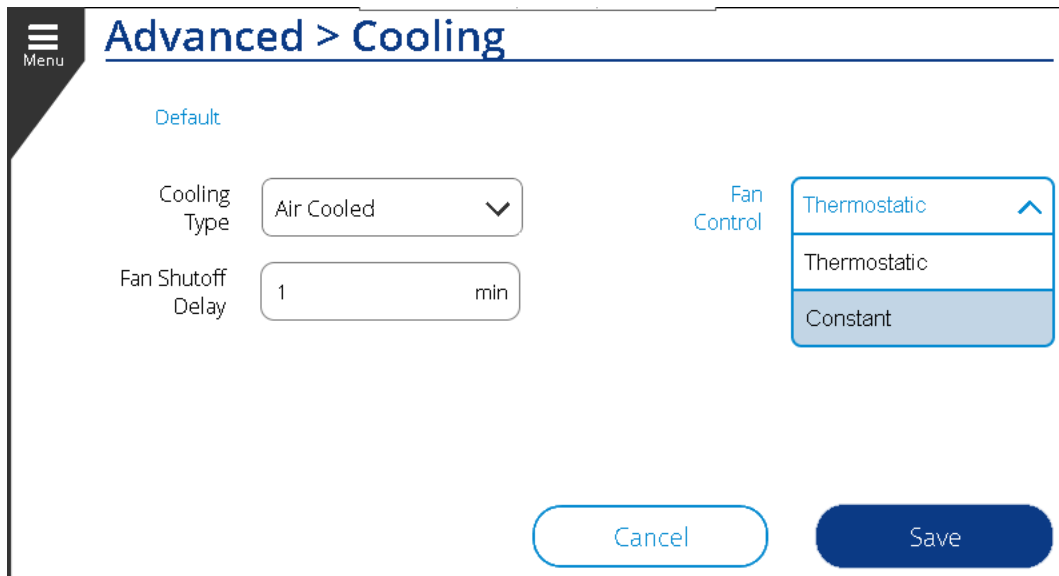

Figure 161: Fan Control

4.7.5.3 Fan Shutoff Delay:

The **Fan Shutoff Delay** is a time delay setting for the fan to continue running for a set period after the main motor has been shut off for additional machine cooling. This setting is shown below in Figure 162, you can see that the fan delay can be set between 0 and 20 minutes.

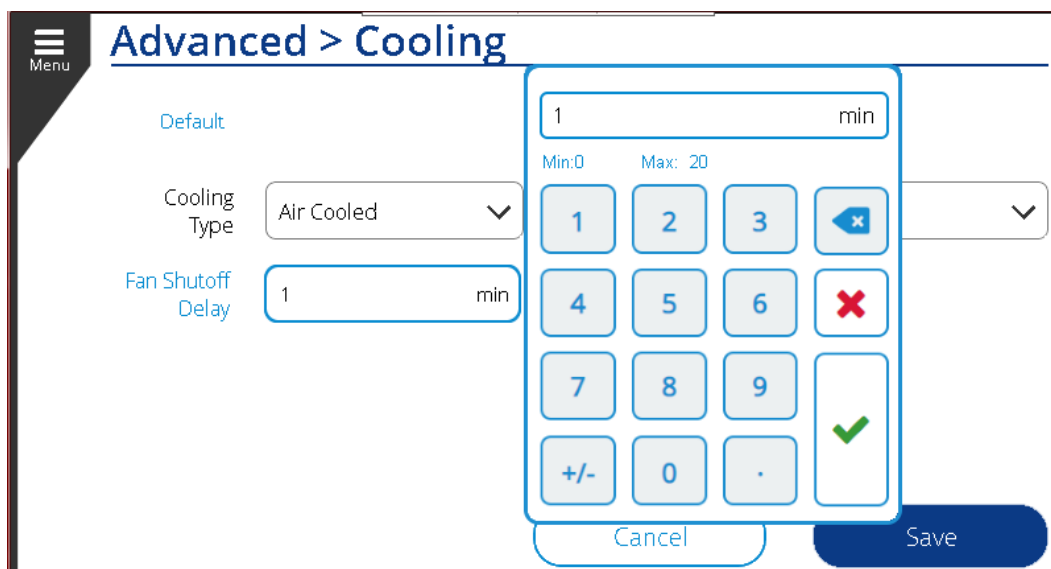
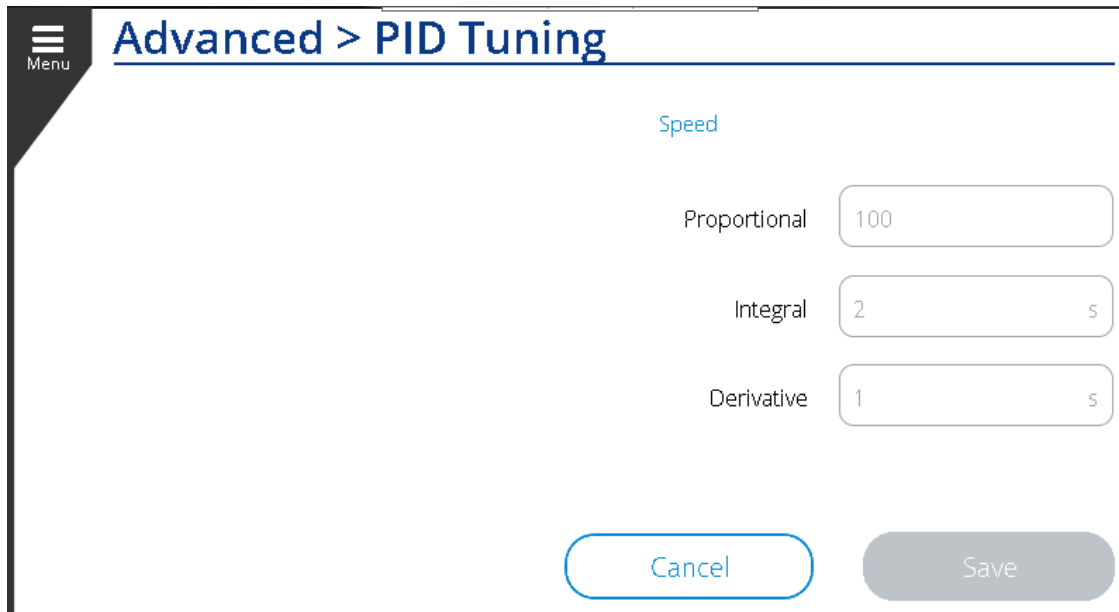

Figure 162: Fan Shutoff Delay

4.7.6 PID Tuning:

The **PID Tuning** settings allows the user to make adjustments to the PID controller parameters for the variable speed drive, inlet valve modulation, and turn valve modulation, depending on the features of the machine. The factory settings are optimized for the machine and will perform well for almost all applications. Only make adjustments to these values if directed by Gardner Denver.



The screenshot shows the 'Advanced > PID Tuning' interface. At the top left is a 'Menu' icon. The title 'Advanced > PID Tuning' is displayed in blue. Below the title, the word 'Speed' is centered. There are three rows of settings, each with a label and a text input field:

- Proportional: 100
- Integral: 2 s
- Derivative: 1 s

At the bottom, there are two buttons: 'Cancel' (outlined in blue) and 'Save' (solid grey).

Figure 163: PID Tuning

4.7.7 Backup / Restore:

The **Backup / Restore** settings allow the user to save the current configuration, restore an already saved configuration, or restore the system to factory default. Figure 164 below shows the **Backup / Restore** setting screen.

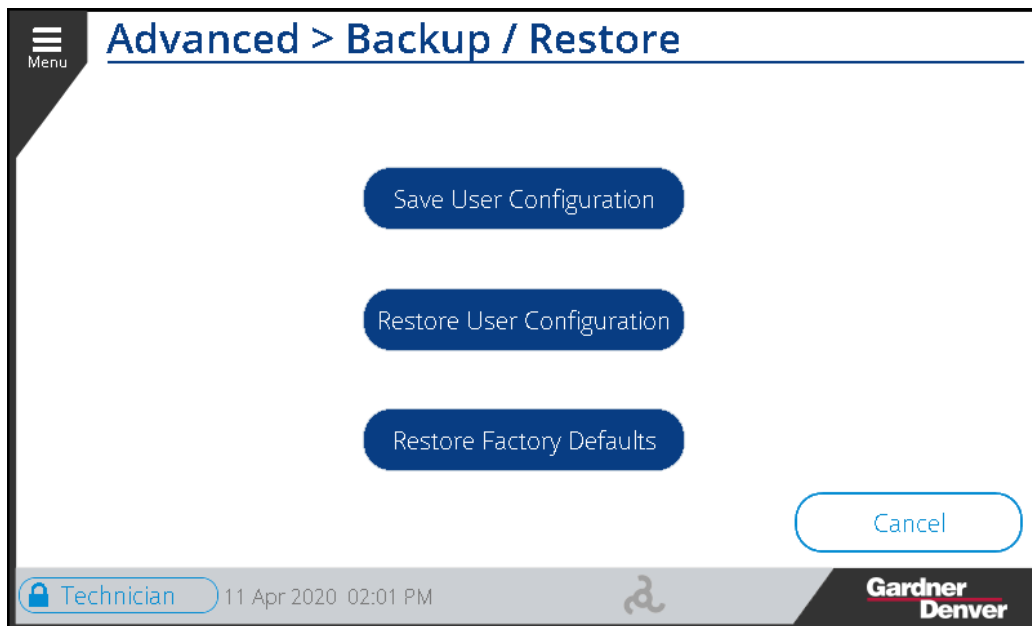

The screenshot shows the 'Advanced > Backup / Restore' interface. At the top left is a 'Menu' icon. The title 'Advanced > Backup / Restore' is displayed in blue. The main area contains three large, rounded blue buttons stacked vertically:

- Save User Configuration
- Restore User Configuration
- Restore Factory Defaults

At the bottom right, there is a 'Cancel' button (outlined in blue). The bottom status bar includes a lock icon, the text 'Technician', the date and time '11 Apr 2020 02:01 PM', a logo, and the 'Gardner Denver' logo.

Figure 164: Backup / Restore

Save User Configuration:

The User can save the current or user defined settings with **Save User Configuration**. Once you hit the button, a dialogue box will confirm user consent to proceed and perform the save operation. Figure 165: Save User Configuration below shows the **Confirm Changes** dialogue box.

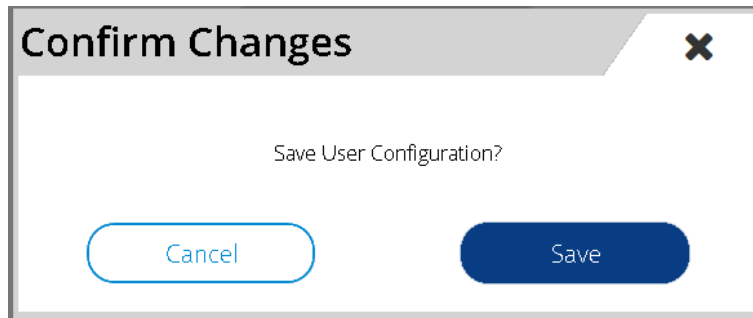

Figure 165: Save User Configuration

The System will then save the settings and values and return to the screen shown in Figure 164: Backup / Restore.

Restore User Configuration:

The User can go to the previously saved settings and parameter values by selecting the **Restore User Configuration** option. This option will only work when there is a stored configuration. Press the **Restore** button and a dialogue box will confirm the changes as shown in Figure 166 below.

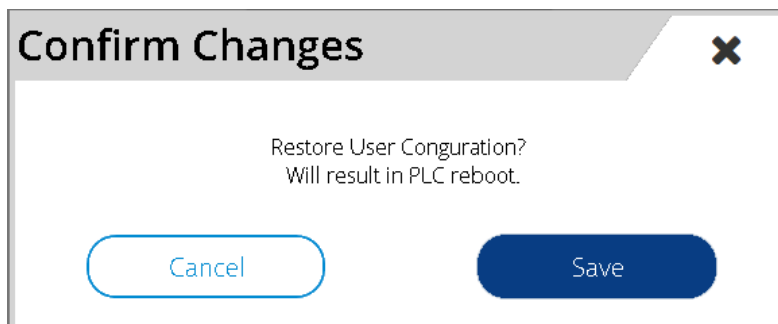

Figure 166: Restore User Configuration

Once you hit the **Save** Button, the controller will reboot to implement the changes.

Restore Factory Default:

The **Restore Factory Default** button will overwrite any changes that have been made and will set the system to the factory default settings. Selecting this option will also bring up a dialogue box to confirm the action, followed by a reboot to implement the changes. Figure 167 below shows the Confirm Changes message.

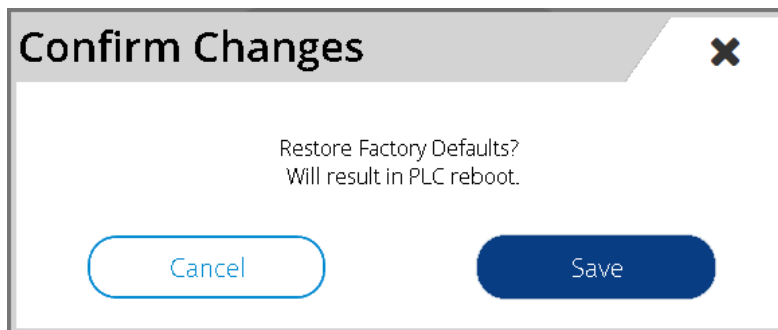

Figure 167: Restore Factory Defaults

SECTION 5

ALARMS

The Governor controller reads many analog inputs and controls a host of digital IO in order to achieve the system objectives and make sure the compressor is running optimally and efficiently. Tests are performed constantly by the Governor controller in order to determine the state of the compressor system at any given moment. Many of the tests are designed to check if certain parameters have been exceeded so that action can be taken immediately to protect the machine, operators, and the facility.

The controller home page includes a banner near the bottom of the screen, which highlights the current status of the machine and alerts the user of any alarms. Figure 168 below shows the home screen of controller with the machine in the *enabled* state. This means the machine is ready to run and there are no current system alarms; indicated by the green color. The colors of the triangles and banner border change depending on the machine state and status. A shutdown or warning will appear as red or yellow on the banner. An example of a shutdown alarm is shown in Figure 169 below.

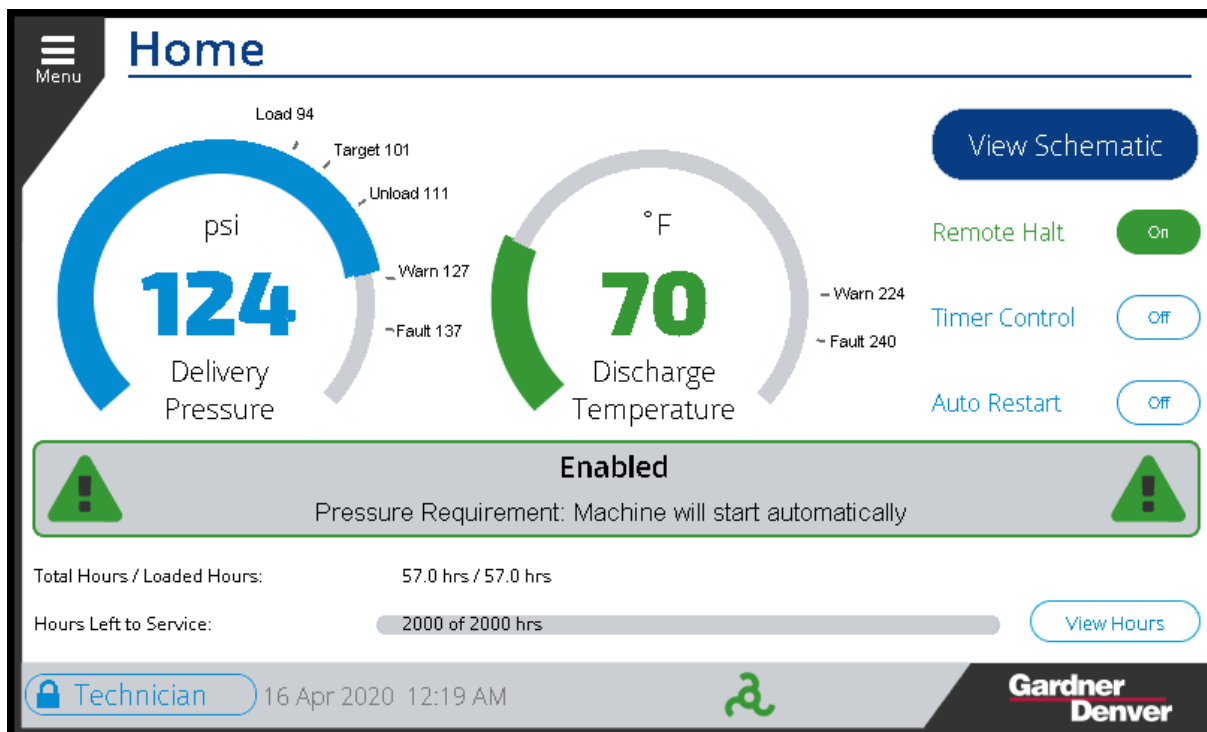

Figure 168 – No Alarm Active

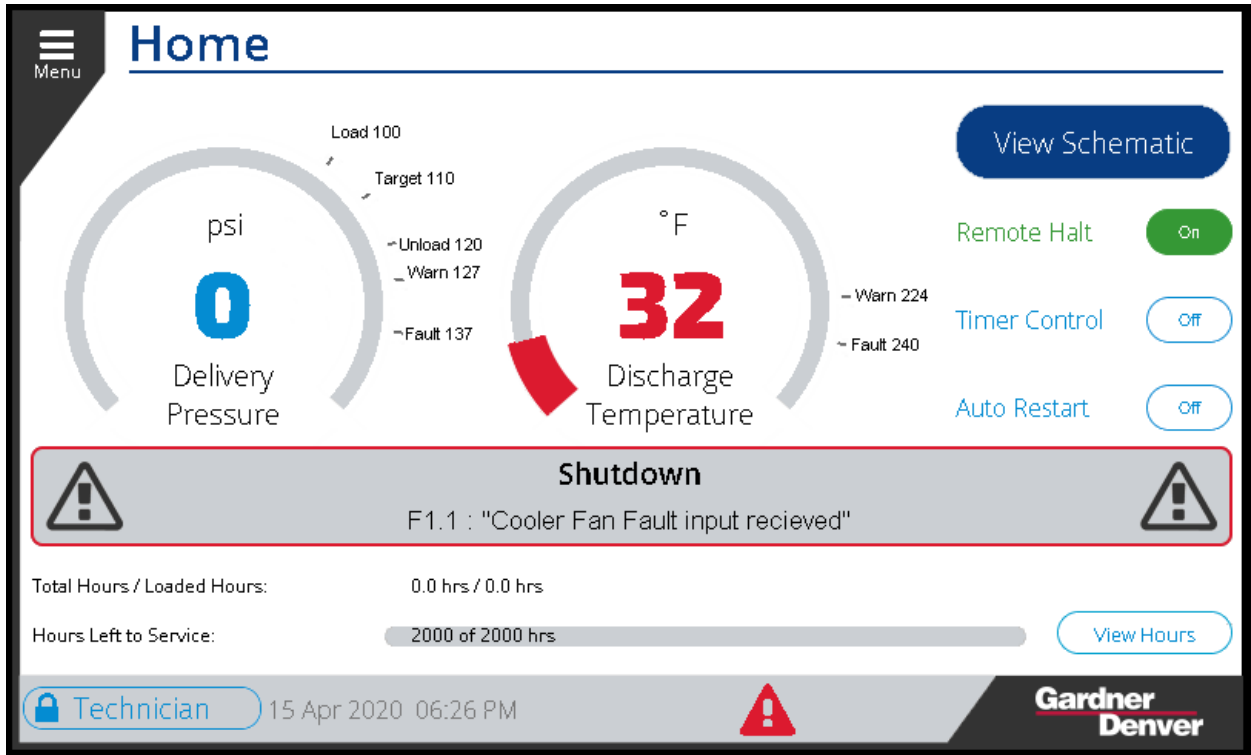

Figure 169 – Alarm Active

To view more information about the particular alarm, click anywhere inside the banner border to open a list of active alarms. Past alarm history can also be found on this page. An alternative way to navigate to this screen is through the main menu, selecting the **Alarms** sub-menu. As you can see in the Figure 170 below, the **Alarm** menu has two sub-options: *Active Alarm* and *Alarm History*.

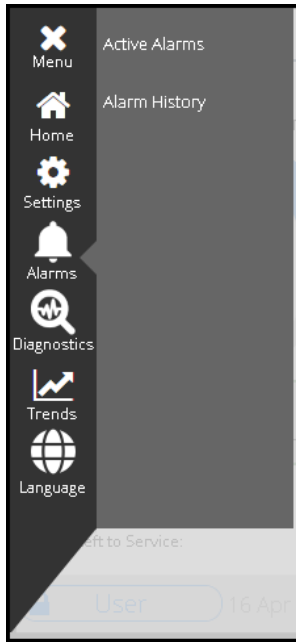

Figure 170 – Alarms Menu Selection

5.1 Active Alarm

The **Active Alarm** page lists all the alarms which are currently active on the machine. Figure 171 below shows the **Active Alarm** page with a few different alarms listed. Note that each alarm has an *Alarm type*,

Timestamp, Code, and Message. Selecting an alarm on the list and clicking the **Info** button will provide more detailed information about the specific alarm.

Alarm	Timestamp	Code	Message
	2020-04-11 14:35:46	C.15	Check IO Modules: Failed to receive Module OK status from all module:
	2020-04-11 14:35:45	M1.1	Motor Fault input recieved
	2020-04-11 14:35:45	P.1	Emergency Stop Pressed
	2020-04-11 14:35:45	F1.1	Cooler Fan Fault input recieved
	2020-04-11 14:35:45	P.2	Low DC Supply Voltage to Controller
	2020-04-11 14:35:45	M1.2	Motor Temperature PTC Fault

Buttons: Contact Info, Info, Alarm History, Reset All

Status: Technician | 13 Apr 2020 11:45 AM | | Gardner Denver

Figure 171: Active Alarms

Alarm:

The alarm column indicates if the alarm is *warning* or *fault*. A fault alarm is an error which needs to be resolved first in order to further machine operation. This is shown by a Red Triangle

Figure 171: Active Alarms above is only showing *faults*. A warning is alarm that needs to be addressed as soon as possible but the system can keep running in most cases. It is shown with a yellow triangle

Timestamp:

The Timestamp column shows the date and time when that particular alarm was triggered. As you can see below, M1.1 alarm was activated on 11th-Apr-2020 at 14:35:45.

	2020-04-11 14:35:45	M1.1	Motor Fault input recieved
--	---------------------	------	----------------------------

Code:

Each alarm has a specific alarm code. The alarm code is an alpha-numeric text. The alarm codes are set up in a *major.minor* format. The major portion of the code defines the component or subsystem and the minor portion of the code defines the specific condition.

Table 44 below provides more definition of the major codes and components it represents in the compressor system.

Table 44: Major Alarms

Major Code	Component	Description
A1	Airend 1	This major code indicates an issue related to the compressor airend, such as high discharge temperature.
P	Package	This category indicates an issue related to the compressor package, such as separator and reservoir sensors.
S	Service	This category indicates issues with service items, such as maintenance timers and filter monitors.
M1	Motor	This category indicates an issue with the main compressor motor, such as over-temperature.
F1	Fan	This category indicates an issue with the fan or fan motor, such as over-temperature.
FV1	VFD Cooling	This category indicates an issue with the cooling system for Variable Speed Drive.
C	Controller	This category indicates an issue with the controller, such as a configuration error or hardware fault.
V1	VFD1	This category indicates an issue with the main compressor variable speed drive 1.
V2	VFD2	This category indicates an issue with the main compressor variable speed drive 2.
SQ	Sequencing	This category indicates an issue with the sequencing communications, such as communication faults.

Refer to Table 45: All Alarms below for a list of the all faults and warnings on the system. This table has a full list of alarms with *major.minor* format. Note, some alarms are specific to the machine configuration and sensors that are present.

Diagnose an Alarm:

The table below shows the possible root cause and first hand remedy for each alarm. Note, that if the remedy listed is not useful and the problem persists, please contact the Gardner-Denver help desk for expert assistance.

Table 45: All Alarms

Alarm List				
Alarm Code	Severity	Alarm Details	Potential Root Cause	Action
Airend 1 Alarms				
A1.0	Fault	Airend Inlet Temperature is below the Fault Limit	Inlet air temperature is too low to start or run the compressor.	Check the site conditions and increase temperature of the inlet air to the compressor.
A1.0	Warning	Airend Inlet Temperature is below the Warning Limit	Inlet air temperature is approaching the minimum limit to start or run the compressor.	Check the site conditions and increase temperature of the inlet air to the compressor.
A1.1	Fault	Airend Inlet Temperature is above the Fault Limit	Inlet air temperature is too high to start or run the compressor.	Check the site conditions and decrease temperature of the inlet air to the compressor.
A1.1	Warning	Airend Inlet Temperature is above the Warning Limit	Inlet air temperature is approaching the maximum limit to start or run the compressor.	Check the site conditions and decrease temperature of the inlet air to the compressor.

A1.3	Fault	Airend Inlet Temperature is shorted, check sensor wiring	Inlet temperature sensor is faulty or the wiring to the sensor is shorted.	Using the wiring schematic for the machine, locate the inlet temperature sensor connection to the controller. Check for any shorted wires at the connector. Inspect the cable for damage between the controller and the sensor. Remove the cable connector from the sensor and use a multi-meter to check the resistance of the sensor and ensure that it is not shorted. It is possible that the sensor may read within range at room temperature but still be faulty once exposed to an elevated temperature or vibration. Replace or repair the wiring or sensor depending on the results of the findings.
A1.4	Fault	Airend Inlet Temperature is Open, check sensor wiring	Inlet temperature sensor is faulty, the wiring to the sensor is broken, or the wiring or connector is disconnected.	Using the wiring schematic for the machine, locate the inlet temperature sensor connection to the controller. Check for disconnected wires, plugs, or loose connections. Inspect the cable for damage between the controller and the sensor. Remove the cable connector from the sensor and use a multi-meter to check the resistance of the sensor and ensure that it is not open (very high resistance). It is possible that the sensor may read within range at room temperature but still be faulty once exposed to an elevated temperature or vibration. Replace or repair the wiring or sensor depending on the results of the findings.
A1.5	Fault	Airend Discharge Temperature Input is below the Fault Limit	Airend discharge temperature is too low to start or run the machine.	Check site conditions and increase the ambient temperature around the airend.
A1.5	Warning	Airend Discharge Temperature Input is below the Warning Limit	Airend discharge temperature is approaching the minimum value to be able to start or run the machine.	Check site conditions and increase the ambient temperature around the airend.
A1.6	Fault	Airend Discharge Temperature Input is above the Fault Limit.	Airend discharge temperature has exceeded the fault limit. The machine has been stopped to prevent damage.	Check the temperature fault setting to ensure that it is not set too close to the normal operating range of the machine. Check site conditions for elevated ambient temperature. Check the condition of compressor cooling functions such as thermal mixing valve and cooler. Check oil condition and oil level. Examine airend for issues. Review history of compressor discharge temperature using the controller trends, data logs, or site maintenance log. A slowly increasing trend of the temperature may indicate overdue maintenance such as cooler cleaning, while a sharp increase may indicate a malfunction. Perform adjustments, cleaning, or repair based on the results of the investigation.

A1.6	Warning	Airend Discharge Temperature Input is above the Warning Limit	Airend discharge temperature has exceeded the warning limit and approaching the maximum limit for safe operation of the machine.	Check the temperature warning setting to ensure that it is not set too close to the normal operating range of the machine. Check site conditions for elevated ambient temperature. Check the condition of compressor cooling functions such as thermal mixing valve and cooler. Check oil condition and oil level. Examine airend for issues. Review history of compressor discharge temperature using the controller trends, data logs, or site maintenance log. A slowly increasing trend of the temperature may indicate overdue maintenance such as cooler cleaning, while a sharp increase may indicate a malfunction. Perform adjustments, cleaning, or repair based on the results of the investigation.
A1.7	Fault	Airend Discharge Temperature Unsafe rate of change on input	The rate of change of the airend discharge temperature exceeded the maximum limit. The controller identified a sharp spike in the temperature and shut down the machine to prevent damage.	This fault will occur when the compressor discharge temperature is in the normal operating range and a sudden increase of temperature has been detected. Check the condition of compressor cooling functions such as thermal mixing valve and cooler. Check oil condition and oil level. Examine airend for issues. Review history of compressor discharge temperature using the controller trends, data logs, or site maintenance log. Perform adjustments, cleaning, or repair based on the results of the investigation.
A1.8	Fault	Airend Discharge Temperature input is shorted, check sensor wiring	Discharge temperature sensor is faulty or the wiring to the sensor is shorted.	Using the wiring schematic for the machine, locate the discharge temperature sensor connection to the controller. Check for any shorted wires at the connector. Inspect the cable for damage between the controller and the sensor. Remove the cable connector from the sensor and use a multi-meter to check the resistance of the sensor and ensure that it is not shorted. It is possible that the sensor may read within range at room temperature but still be faulty once exposed to an elevated temperature or vibration. Replace or repair the wiring or sensor depending on the results of the findings.
A1.9	Fault	Airend Discharge Temperature Input is open, check sensor wiring.	Discharge temperature sensor is faulty, the wiring to the sensor is broken, or the wiring or connector is disconnected.	Using the wiring schematic for the machine, locate the discharge temperature sensor connection to the controller. Check for disconnected wires, plugs, or loose connections. Inspect the cable for damage between the controller and the sensor. Remove the cable connector from the sensor and use a multi-meter to check the resistance of the sensor and ensure that it is not open (very high resistance). It is possible that the sensor may read within range at room temperature but still be faulty once exposed to an elevated temperature or vibration. Replace or repair the wiring or sensor depending on the results of the findings.
A1.10	Fault	Airend Inlet Pressure Input is below the Fault Limit	Airend inlet pressure is too low to operate the machine. Blockage on the air filter or inlet valve.	Inspect inlet air filter, clean/replace as necessary.

A1.10	Warning	Airend Inlet Pressure Input is below the Warning Limit	Airend inlet pressure is approaching the minimum value to be able to start or run the machine.	Inspect inlet air filter, clean/replace as necessary.
A1.12	Fault	Airend Inlet Pressure Input is shorted, check sensor wiring	Airend Inlet Pressure sensor is faulty or the wiring to the sensor is shorted.	Using the wiring schematic for the machine, locate the airend inlet pressure sensor connection to the controller. Check for any shorted wires at the connector. Inspect the cable for damage between the controller and the sensor. Using a multi-meter with process clamp meter measure the current (mA) in the signal wire between the sensor and controller. The signal should be in the range of 4-20mA. Replace or repair the wiring or sensor depending on the results of the findings.
A1.13	Fault	Airend Inlet Pressure Input is open, check sensor wiring.	Airend Inlet temperature sensor is faulty, the wiring to the sensor is broken, or the wiring or connector is disconnected.	Using the wiring schematic for the machine, locate the airend inlet pressure sensor connection to the controller. Check for any shorted wires at the connector. Inspect the cable for damage between the controller and the sensor. Using a multi-meter with process clamp meter measure the current (mA) in the signal wire between the sensor and controller. The signal should be in the range of 4-20mA. Replace or repair the wiring or sensor depending on the results of the findings.
A1.15	Fault	Discharge pressure above the Fault Limit.	The package discharge pressure has exceeded the fault limit.	Inspect the oil level and condition. Check the performance of the thermal mixing valve and oil cooler if equipped.
A1.15	Warning	Discharge pressure above the Warning Limit	The package discharge pressure has exceeded the warning limit and is approaching the fault limit.	Inspect the oil level and condition. Check the performance of the thermal mixing valve and oil cooler if equipped.
A1.16	Fault	Discharge pressure sensor shorted	Discharge pressure input is faulty or the wiring to the sensor is shorted.	Using the wiring schematic for the machine, locate the plant delivery pressure sensor connection to the controller. Check for any shorted wires at the connector. Inspect the cable for damage between the controller and the sensor. Using a multi-meter with process clamp meter measure the current (mA) in the signal wire between the sensor and controller. The signal should be in the range of 4-20mA. Replace or repair the wiring or sensor depending on the results of the findings.
A1.17	Fault	Discharge pressure sensor open	Discharge pressure input is faulty, the wiring to the sensor is broken, or the wiring or connector is disconnected.	Using the wiring schematic for the machine, locate the plant delivery pressure sensor connection to the controller. Check for disconnected wires, plugs, or loose connections. Inspect the cable for damage between the controller and the sensor. Using a multi-meter with process clamp meter measure the current (mA) in the signal wire between the sensor and controller. The signal should be in the range of 4-20mA. Replace or repair the wiring or sensor depending on the results of the findings.
Controller Alarms				
C.0	Warning	Network Error	Network configuration error	Check network configuration settings.

C.1	Fault	Machine configuration error	The machine configuration file selected is invalid, corrupt, or otherwise not compatible.	Check the machine definition and configuration file selections and reload if necessary. If the problem persists, export the logs from the controller and contact Gardner Denver service.
C.2	Fault	Error on Compressor control task	Internal software error or misconfiguration	Check the configuration settings. If the problem persists, export the logs from the controller and contact Gardner Denver service.
C.3	Warning	Date and Time error	Error setting date and time, most likely due to invalid entries.	Check the date and time settings and attempt to set them. If the problem persists, export the logs from the controller and contact Gardner Denver service.
C.4	Fault	Error in valve control task	Internal software error or misconfiguration	Check the configuration settings. If the problem persists, export the logs from the controller and contact Gardner Denver service.
C.5	Warning	Error on Data log Task	Internal software or hardware error	Export logs from the controller and contact Gardner Denver service.
C.6	Fault	Error in Oil control task	Internal software error or misconfiguration	Check the machine configuration settings. If the problem persists, export the logs from the controller and contact Gardner Denver service.
C.7	Information	Manual snapshot taken	Snapshot function activated from machine schematic view	None. Info captured with the snapshot event may be viewed through the alarm history or by exporting logs.
C.8	Warning	User access task error	Internal software error or misconfiguration	Export logs from the controller and contact Gardner Denver service.
C.9	Warning	Error on FX30 USB link task	Internal error in communication with iConn module.	Check the iConn diagnostics page to verify communication between the iConn and controller. Check USB cable between the iConn and controller and the power cable to the iConn. If the problem persists, export the logs from the controller and contact Gardner Denver service.
C.10	Warning	Error on alarm info task	Internal software error or corrupt alarm info file detected.	Check functionality of the alarm info feature by viewing the alarm info associated with alarms on the system. If the problem persists, export the logs from the controller and contact Gardner Denver service.
C.11	Fault	Invalid parameters in Machine Configuration	Invalid parameters were detected in the machine configuration file that was attempted to be loaded. This generally indicates that the version of the machine configuration file does not match the controller firmware version.	Check the machine definition and configuration file selections and reload if necessary. If the problem persists, export the logs from the controller and contact Gardner Denver service.
C.12	Warning	Error on Audit page	Internal software error or inability to save audit log	Check the functionality of the Audit log page. If the problem persists, export the logs from the controller and contact Gardner Denver service.
C.13	Fault	Error on cooling control task	Internal software error or misconfiguration	Check the machine configuration settings. If the problem persists, export the logs from the controller and contact Gardner Denver service.
C.14	Fault	Monitor Task Error	Internal software error or misconfiguration	Check the machine configuration settings. If the problem persists, export the logs from the controller and contact Gardner Denver service.

C.15	Fault	Check IO Modules: Failed to receive Module OK status from all modules	Communication between the controller and IO module has been interrupted, or the wrong software configuration has been loaded that does not match the module that is connected.	<ol style="list-style-type: none"> 1. If the problem is persistent and cannot be cleared, make sure that the correct version of software has been loaded onto the controller. 2. Check the wiring between the IO module and the controller on the CAN bus for loose connections. 3. Check that the CAN bus termination resistor DIP switch is set to ON the IO module (for machines with more than one IO module, the last IO module on the bus should have the termination resistor enabled). 4. Check the power wiring to the IO module to ensure that there are no loose connections. 5. Check the status LEDs on the IO module and controller. The CAN LEDs should indicate activity on the bus. 6. Intermittent C.15 faults are typically the result of noise induced on the CAN bus disrupting communications. To resolve these, (a) make sure that the CAN bus shield is terminated to the brackets at the controller and at the IO module, (b) eliminate close parallel runs of the CAN bus with the AC line voltage in the panel, (c) check ground from back panel to enclosure door and controller, (d) check for continuity between panel ground and the metal mounting brackets on the IO module.
C.18	Warning	Error in Backup/Restore	An error occurred trying to backup or restore the machine configuration using the backup/restore functionality.	If the problem persists, export the logs from the controller and contact Gardner Denver service.
C.19	Warning	Error transferring logs to USB	An error occurred while trying to export the logs to a USB device.	Remove and re-insert the USB device and try to save the logs again. Ensure that the USB device is formatted in a FAT16 format and make sure that it is not removed during the save operation. Try a different USB device. If the problem persists, contact Gardner Denver service.
C.20	Warning	Error updating software	An error occurred during a software update from an external device or through iConn.	Check that the software has been installed properly on the device being used to transfer the update to the controller. Attempt to update again. Reformat the USB device using the FAT16 format, or try a different USB device. If the problem persists, contact Gardner Denver service.
C.21	Warning	More than one Modbus slave configured	A misconfiguration on the Modbus slave settings has been detected.	Check the machine configuration settings and reload if necessary. If the problem persists, contact Gardner Denver service.
C.22	Warning	More than one Sequencing configured	A misconfiguration on the sequencing settings has been detected.	Check the machine configuration settings and reload if necessary. If the problem persists, contact Gardner Denver service.
C.23	Warning	More than one Modbus master configured	A misconfiguration on the Modbus master settings has been detected.	Check the machine configuration settings and reload if necessary. If the problem persists, contact Gardner Denver service.
C.48	Fault	Digital Output 1 Short High	The feedback value of Digital Output 1 is high while the controller is	<ol style="list-style-type: none"> 1. Check the wiring connected to the associated digital output for any shorts to 24VDC. 2. Using the digital output diagnostics page,

			attempting to set it low. This indicates that the output pin is shorted to 24VDC.	<p>observe the feedback output for the digital output while forcing the value ON and OFF. If shorted high, the feedback will remain ON regardless of the forced value.</p> <p>3. Remove any wires from the digital output at the IO module connection and see if the feedback begins to operate following the commanded value. If the output operates correctly without anything connected to the module, the problem is most likely with the wiring outside the controller. If the problem persists after removing the wires from the connector, the problem is most likely inside the IO module.</p>
C.49	Fault	Digital Output 2 Short High	The feedback value of Digital Output 2 is high while the controller is attempting to set it low. This indicates that the output pin is shorted to 24VDC.	
C.50	Fault	Digital Output 3 Short High	The feedback value of Digital Output 3 is high while the controller is attempting to set it low. This indicates that the output pin is shorted to 24VDC.	
C.51	Fault	Digital Output 4 Short High	The feedback value of Digital Output 4 is high while the controller is attempting to set it low. This indicates that the output pin is shorted to 24VDC.	
C.52	Fault	Digital Output 5 Short High	The feedback value of Digital Output 5 is high while the controller is attempting to set it low. This indicates that the output pin is shorted to 24VDC.	
C.53	Fault	Digital Output 6 Short High	The feedback value of Digital Output 6 is high while the controller is attempting to set it low. This indicates that the output pin is shorted to 24VDC.	
C.54	Fault	Digital Output 7 Short High	The feedback value of Digital Output 7 is high while the controller is attempting to set it low. This indicates that the output pin is shorted to 24VDC.	
C.55	Fault	Digital Output 8 Short High	The feedback value of Digital Output 8 is high while the controller is attempting to set it low. This indicates that the output pin is shorted to 24VDC.	
C.56	Fault	Digital Output 9 Short High	The feedback value of Digital Output 9 is high while the controller is attempting to set it low. This indicates that the	

			output pin is shorted to 24VDC.
C.57	Fault	Digital Output 10 Short High	The feedback value of Digital Output 10 is high while the controller is attempting to set it low. This indicates that the output pin is shorted to 24VDC.
C.58	Fault	Digital Output 11 Short High	The feedback value of Digital Output 11 is high while the controller is attempting to set it low. This indicates that the output pin is shorted to 24VDC.
C.59	Fault	Digital Output 12 Short High	The feedback value of Digital Output 12 is high while the controller is attempting to set it low. This indicates that the output pin is shorted to 24VDC.
C.60	Fault	Digital Output 13 Short High	The feedback value of Digital Output 13 is high while the controller is attempting to set it low. This indicates that the output pin is shorted to 24VDC.
C.61	Fault	Digital Output 14 Short High	The feedback value of Digital Output 14 is high while the controller is attempting to set it low. This indicates that the output pin is shorted to 24VDC.
C.62	Fault	Digital Output 15 Short High	The feedback value of Digital Output 15 is high while the controller is attempting to set it low. This indicates that the output pin is shorted to 24VDC.
C.63	Fault	Digital Output 16 Short High	The feedback value of Digital Output 16 is high while the controller is attempting to set it low. This indicates that the output pin is shorted to 24VDC.
C.64	Fault	Digital Output 17 Short High	The feedback value of Digital Output 17 is high while the controller is attempting to set it low. This indicates that the output pin is shorted to 24VDC.

C.65	Fault	Digital Output 18 Short High	The feedback value of Digital Output 18 is high while the controller is attempting to set it low. This indicates that the output pin is shorted to 24VDC.	
C.66	Fault	Digital Output 19 Short High	The feedback value of Digital Output 19 is high while the controller is attempting to set it low. This indicates that the output pin is shorted to 24VDC.	
C.67	Fault	Digital Output 20 Short High	The feedback value of Digital Output 20 is high while the controller is attempting to set it low. This indicates that the output pin is shorted to 24VDC.	
C.68	Fault	Digital Output 1 Short Low	The feedback value of Digital Output 1 is low while the controller is attempting to set it high. This indicates that the output pin is shorted to ground or the output is overloaded.	<p>1. Check the wiring connected to the associated digital output for any shorts to ground or DC-. Check that the device that is connected to the output (solenoid valve, contactor coil, etc.) is not shorted by measuring impedance with a multi-meter.</p> <p>2. Using the digital output diagnostics page, observe the feedback output for the digital output while forcing the value ON and OFF. If shorted or overloaded, the Feedback result will stay OFF regardless of the forced value.</p> <p>3. Remove any wires from the digital output at the IO module connection and see if the feedback begins to operate following the commanded value. If the output operates correctly without anything connected to the module, the problem is most likely with the wiring outside the controller. If the problem persists after removing the wires from the connector, the problem is most likely inside the IO module.</p>
C.69	Fault	Digital Output 2 Short Low	The feedback value of Digital Output 2 is low while the controller is attempting to set it high. This indicates that the output pin is shorted to ground or the output is overloaded.	
C.70	Fault	Digital Output 3 Short Low	The feedback value of Digital Output 3 is low while the controller is attempting to set it high. This indicates that the output pin is shorted to ground or the output is overloaded.	
C.71	Fault	Digital Output 4 Short Low	The feedback value of Digital Output 4 is low while the controller is attempting to set it high. This indicates that the output pin is shorted to ground or the output is overloaded.	
C.72	Fault	Digital Output 5 Short Low	The feedback value of Digital Output 5 is low while the controller is attempting to set it high. This indicates that the output pin is shorted to	

			ground or the output is overloaded.
C.73	Fault	Digital Output 6 Short Low	The feedback value of Digital Output 6 is low while the controller is attempting to set it high. This indicates that the output pin is shorted to ground or the output is overloaded.
C.74	Fault	Digital Output 7 Short Low	The feedback value of Digital Output 7 is low while the controller is attempting to set it high. This indicates that the output pin is shorted to ground or the output is overloaded.
C.75	Fault	Digital Output 8 Short Low	The feedback value of Digital Output 8 is low while the controller is attempting to set it high. This indicates that the output pin is shorted to ground or the output is overloaded.
C.76	Fault	Digital Output 9 Short Low	The feedback value of Digital Output 9 is low while the controller is attempting to set it high. This indicates that the output pin is shorted to ground or the output is overloaded.
C.77	Fault	Digital Output 10 Short Low	The feedback value of Digital Output 10 is low while the controller is attempting to set it high. This indicates that the output pin is shorted to ground or the output is overloaded.
C.78	Fault	Digital Output 11 Short Low	The feedback value of Digital Output 11 is low while the controller is attempting to set it high. This indicates that the output pin is shorted to ground or the output is overloaded.
C.79	Fault	Digital Output 12 Short Low	The feedback value of Digital Output 12 is low while the controller is attempting to set it high. This indicates that the output pin is shorted to

			ground or the output is overloaded.
C.80	Fault	Digital Output 13 Short Low	The feedback value of Digital Output 13 is low while the controller is attempting to set it high. This indicates that the output pin is shorted to ground or the output is overloaded.
C.81	Fault	Digital Output 14 Short Low	The feedback value of Digital Output 14 is low while the controller is attempting to set it high. This indicates that the output pin is shorted to ground or the output is overloaded.
C.82	Fault	Digital Output 15 Short Low	The feedback value of Digital Output 15 is low while the controller is attempting to set it high. This indicates that the output pin is shorted to ground or the output is overloaded.
C.83	Fault	Digital Output 16 Short Low	The feedback value of Digital Output 16 is low while the controller is attempting to set it high. This indicates that the output pin is shorted to ground or the output is overloaded.
C.84	Fault	Digital Output 17 Short Low	The feedback value of Digital Output 17 is low while the controller is attempting to set it high. This indicates that the output pin is shorted to ground or the output is overloaded.
C.85	Fault	Digital Output 18 Short Low	The feedback value of Digital Output 18 is low while the controller is attempting to set it high. This indicates that the output pin is shorted to ground or the output is overloaded.
C.86	Fault	Digital Output 19 Short Low	The feedback value of Digital Output 19 is low while the controller is attempting to set it high. This indicates that the output pin is shorted to

			ground or the output is overloaded.	
C.87	Fault	Digital Output 20 Short Low	The feedback value of Digital Output 20 is low while the controller is attempting to set it high. This indicates that the output pin is shorted to ground or the output is overloaded.	
C.88	Fault	Supply Bank 1 Fault	Digital output bank 1 has lost 24VDC supply voltage.	Pin 1 of each set of four digital output pins is used to provide power for switching the outputs. Check pin 1 of the corresponding bank (1 = X07, 2 = X08, 3 = X09) and verify that it is being supplied with 24VDC. Correct wiring as needed.
C.89	Fault	Supply Bank 2 Fault	Digital output bank 2 has lost 24VDC supply voltage.	
C.90	Fault	Supply Bank 3 Fault	Digital output bank 3 has lost 24VDC supply voltage.	
C.92	Warning	Error on create directories task	An error occurred trying to create directories on the internal filesystem. Internal software or hardware issue or the operation was interrupted.	Export the logs from the controller and Contact Gardner Denver service.
C.93	Warning	Error changing Baud Rate	An error occurred trying to write new baud rate settings to the serial port. Internal software or hardware issue or the operation was interrupted.	Check the communication configuration and attempt to save again. If the problem persists, export the logs from the controller and contact Gardner Denver service.
C.94	Fault	Controller Initialization Failed	Internal software or hardware error or misconfiguration.	Reboot the controller. If the problem persists, export the logs from the controller and contact Gardner Denver service.
C.95	Fault	Communications with VFD Cooling Lost	Modbus communications lost with cooling fan VFD	Check the connections on the RS485 link between the VFD and the controller. Make sure that cable shields are properly terminated. Check that the termination resistors are enabled on the VFD that is the last link in the RS485 network.
C.96	Fault	Communications with VFD Lost	Modbus communications lost with main motor VFD.	Check the connections on the RS485 link between the VFD and the controller. Make sure that cable shields are properly terminated. Check that the termination resistors are enabled on the VFD that is the last link in the RS485 network.
C.97	Warning	Machine Definition recipe save failed, new file created.	An error occurred during an attempt to save the machine definition file. The operation may have been interrupted. The controller was able to recover.	If the problem persists, export the logs from the controller and contact Gardner Denver service.
C.98	Warning	Machine Definition recipe save partially failed	An error occurred during an attempt to save the machine definition file. The operation may have	If the problem persists, export the logs from the controller and contact Gardner Denver service.

			been interrupted. The controller was able to recover.	
C.99	Warning	Machine Definition recipe load failed	An error occurred when the controller tried to read the machine definition file. The operation may have been interrupted.	Reboot the controller. If the problem persists, export the logs from the controller and contact Gardner Denver service.
C.100	Warning	Machine Definition recipe load partially failed	An error occurred when the controller tried to read the machine definition file. The operation may have been interrupted.	Reboot the controller. If the problem persists, export the logs from the controller and contact Gardner Denver service.
C.101	Warning	Machine Parameter recipe save failed, new file created.	An error occurred during an attempt to save the machine parameter file. The operation may have been interrupted. The controller was able to recover.	If the problem persists, export the logs from the controller and contact Gardner Denver service.
C.102	Warning	Machine Parameter recipe save partially failed	An error occurred during an attempt to save the machine parameter file. The operation may have been interrupted. The controller was able to recover.	If the problem persists, export the logs from the controller and contact Gardner Denver service.
C.103	Warning	Machine Parameter recipe load failed	An error occurred when the controller tried to read the machine parameter file. The operation may have been interrupted.	Reboot the controller. If the problem persists, export the logs from the controller and contact Gardner Denver service.
C.104	Warning	Machine Parameter recipe load partially failed	An error occurred when the controller tried to read the machine parameter file. The operation may have been interrupted.	Reboot the controller. If the problem persists, export the logs from the controller and contact Gardner Denver service.
C.105	Warning	Machine Configuration recipe save failed, new file created.	An error occurred during an attempt to save the machine configuration file. The operation may have been interrupted. The controller was able to recover.	If the problem persists, export the logs from the controller and contact Gardner Denver service.
C.106	Warning	Machine Configuration recipe save partially failed	An error occurred when the controller tried to read the machine configuration file. The operation may have been interrupted.	Reboot the controller. If the problem persists, export the logs from the controller and contact Gardner Denver service.
C.107	Warning	Machine Configuration recipe load failed	An error occurred when the controller tried to read the machine configuration file. The	Reboot the controller. If the problem persists, export the logs from the controller and contact Gardner Denver service.

			operation may have been interrupted.	
C.108	Warning	Machine Configuration recipe load partially failed	An error occurred during an attempt to save the machine parameter file. The operation may have been interrupted. The controller was able to recover.	If the problem persists, export the logs from the controller and contact Gardner Denver service.
C.109	Warning	Alarm Info recipe save failed	An error occurred during an attempt to save the alarm info file. The operation may have been interrupted. The controller was able to recover.	If the problem persists, export the logs from the controller and contact Gardner Denver service.
C.110	Warning	Alarm Info recipe save partially failed	An error occurred when the controller tried to read the alarm info file. The operation may have been interrupted.	Reboot the controller. If the problem persists, export the logs from the controller and contact Gardner Denver service.
C.111	Warning	Alarm Info recipe load failed	An error occurred when the controller tried to read the alarm info file. The operation may have been interrupted.	Reboot the controller. If the problem persists, export the logs from the controller and contact Gardner Denver service.
C.112	Warning	Alarm Info recipe load partially failed	An error occurred during an attempt to save the machine parameter file. The operation may have been interrupted. The controller was able to recover.	If the problem persists, export the logs from the controller and contact Gardner Denver service.
C.113	Warning	Permanent Variables recipe save failed	An error occurred during an attempt to save the permanent variables file. The operation may have been interrupted. The controller was able to recover.	If the problem persists, export the logs from the controller and contact Gardner Denver service.
C.114	Warning	Permanent Variables recipe save partial failed	An error occurred when the controller tried to read the permanent variables file. The operation may have been interrupted.	Reboot the controller. If the problem persists, export the logs from the controller and contact Gardner Denver service.
C.115	Warning	Permanent Variables recipe load failed	An error occurred when the controller tried to read the permanent variables file. The operation may have been interrupted.	Reboot the controller. If the problem persists, export the logs from the controller and contact Gardner Denver service.
C.116	Warning	Permanent Variables recipe load partial failed	An error occurred during an attempt to save the machine parameter file. The operation may have been interrupted. The	If the problem persists, export the logs from the controller and contact Gardner Denver service.

			controller was able to recover.	
C.117	Fault	Error on machine parameters	Machine parameters have been corrupted.	Reboot the controller. If the problem persists, export the logs from the controller and contact Gardner Denver service.
C.118	Fault	Error on the Permanent Variable Tasks	An error occurred on the task that processes and manages permanent variables. Internal software or hardware issue.	Reboot the controller. If the problem persists, export the logs from the controller and contact Gardner Denver service.
C.119	Warning	Snapshot Task error	An error occurred when attempting to take or process a snapshot.	Attempt to take the snapshot again. If the problem persists, export the logs from the controller and contact Gardner Denver service.
C.120	Information	Data log recording completed successfully	Informational. Log recording was successful.	No action needed
C.121	Warning	Data log recording interrupted and aborted	Data log recording was interrupted.	Reboot the controller. If the problem persists, export the logs from the controller and contact Gardner Denver service.
C.122	Warning	Data log value of a registered process variable has violated limits	An error occurred with the format of one of the variables being logged.	Reboot the controller. If the problem persists, export the logs from the controller and contact Gardner Denver service.
C.123	Information	Snapshot recording completed successfully	Informational. Snapshot recording process was successful.	No action needed
C.124	Warning	Snapshot recording interrupted and aborted	Snapshot recording was interrupted.	Reboot the controller. If the problem persists, export the logs from the controller and contact Gardner Denver service.
C.125	Warning	Snapshot value of a registered process variable has violated limits	An error occurred with the format of one of the variables being logged.	Reboot the controller. If the problem persists, export the logs from the controller and contact Gardner Denver service.
C.126	Fault	Error on the EIP variable Tasks	The Ethernet IP task has encountered an issue.	If the problem persists, export the logs from the controller and contact Gardner Denver service.
C.127	Warning	No EIP connection detected, check network cables.	An Ethernet IP connection cannot be detected. Cables may be disconnected or the network is not configured properly.	Check cables and network configuration. If the problem persists, export the logs from the controller and contact Gardner Denver service.
C.128	Warning	Firewall Setting error	A misconfiguration of the firewall has been detected.	Reboot the controller. If the problem persists, export the logs from the controller and contact Gardner Denver service.
C.129	Warning	Error on Profiler configuration task	An error was encountered trying to set up the software profiler. Internal software issue or the task was interrupted.	Reboot the controller. If the problem persists, export the logs from the controller and contact Gardner Denver service.

C.130	Warning	Cell-Data importer task error	An error occurred when trying to import diagnostic data from the iConn unit.	Check the power cable to the iConn and the USB cable between the iConn and controller. If the problem persists, export the logs from the controller and contact Gardner Denver service.
C.131	Warning	Cell-Data exporter task error	An error occurred when trying to export data to the iConn unit.	Check the power cable to the iConn and the USB cable between the iConn and controller. If the problem persists, export the logs from the controller and contact Gardner Denver service.
C.132	Information	User blocked due to too many failed login attempts	Too many failed login attempts have occurred. The user has been blocked for 30 seconds after five failed attempts.	Attempt to log in with the correct passcode. If you do not have the passcode, log in with the next higher user level and reset the passcode for the user level with the lost passcode.
C.133	Warning	Import Hardware-Configuration has failed.	An error occurred trying to load the hardware configuration file for the system.	Reboot the controller. If the problem persists, export the logs from the controller and contact Gardner Denver service.
C.134	Information	New Hardware-Configuration imported	Informational. Hardware configuration was successful.	No action needed
C.135	Information	Hardware-Configuration was changed externally	The hardware configuration was changed and is no longer synchronized with the hardware.	Reboot the controller. If the problem persists, export the logs from the controller and contact Gardner Denver service.
C.136	Fault	Error in IO Mapping task	An error occurred in trying to load the IO map for the controller. Possible misconfiguration.	Reboot the controller. If the problem persists, export the logs from the controller and contact Gardner Denver service.
C.137	Fault	Internal Configuration Fault - Bad VFD Address	A misconfiguration was detected where one of the VFDs in the system is assigned an invalid address.	Check the configuration and definition files that have been loaded and ensure that they match the machine. Reload if necessary. If the problem persists, export the logs from the controller and contact Gardner Denver service.
C.138	Fault	Error Communicating with Precision Mixing Valve	Error in Modbus communications with precision mixing valve.	Check the RS485 connections between the controller and the mixing valve. Ensure that the cable shields are terminated properly. Check for loose connections. Check to make sure that the PMV has power.
C.139	Warning	Error on the PRJ variable Tasks	An error occurred loading the project info task. Internal software issue.	Reboot the controller. If the problem persists, export the logs from the controller and contact Gardner Denver service.
C.140	Warning	Error on Serial Data model task	An error occurred loading the data model task used to supply data to external communication protocols. Internal software issue.	Reboot the controller. If the problem persists, export the logs from the controller and contact Gardner Denver service.
C.141	Warning	Error on Modbus Data model task	An error occurred loading the data model task used to supply data to external communication protocols. Internal software issue.	Reboot the controller. If the problem persists, export the logs from the controller and contact Gardner Denver service.

C.142	Warning	Error during updating serial configuration on Panel	An error occurred when trying to update the serial port configuration on the controller. The operation may have been interrupted.	Reboot the controller. If the problem persists, export the logs from the controller and contact Gardner Denver service.
C.143	Warning	Error in sequencing control task	An error occurred during the operation of the sequencing control task. Internal software issue. The operation may have been interrupted.	Reboot the controller. If the problem persists, export the logs from the controller and contact Gardner Denver service.
C.144	Warning	Error in HMI Serial	An error was detected in serial communications on the HMI serial port (RS485-0).	Check wiring and all devices connected to the RS485-0 port. Check configuration of the devices to ensure that they match. This problem is generally related to baud rate or other communication misconfigurations. If the problem persists, export the logs from the controller and contact Gardner Denver service.
C.145	Warning	Error in IOBrick RS485-1 Serial	An error was detected in serial communications on the IO Module serial port RS485-1.	Check wiring and all devices connected to the RS485-1 port. Check configuration of the devices to ensure that they match. This problem is generally related to baud rate or other communication misconfigurations. If the problem persists, export the logs from the controller and contact Gardner Denver service.
C.146	Warning	Error in IOBrick RS485-2 Serial	An error was detected in serial communications on the IO Module serial port RS485-2.	Check wiring and all devices connected to the RS485-2 port. Check configuration of the devices to ensure that they match. This problem is generally related to baud rate or other communication misconfigurations. If the problem persists, export the logs from the controller and contact Gardner Denver service.
C.147	Warning	File Backup Failure Warning	Backup operation failed. The operation may have been interrupted.	Attempt the backup operation again. If the problem persists, export the logs from the controller and contact Gardner Denver for service.
C.148	Fault	Process Control task entered an unknown state.	An error was detected in the process control task. Internal software issue.	Export the logs from the controller and contact Gardner Denver service.
C.149	Information	Archive available	Informational. An archive of logs is available for download.	No action needed
C.150	Warning	Archiving stopped (maximum number of archives reached)	Too many archive files exist on the controller.	Export the logs from the controller. If the problem persists, contact Gardner Denver service.
Fan Alarms				
F1.0	Fault	Cooler Fan Auxiliary Input does not match expected value	The contactor coil failed or the wiring to the coil or auxiliary contact is disconnected. The contactor could be stuck in the open or closed position.	Check wiring to the contactor coil and auxiliary contact. Use the digital output IO diagnostics function in the controller to check operation of the contactor. If the contactor is not operating properly use an ohm-meter to check the resistance on the coil of the contactor. Attempt to operate the contactor manually to ensure it is not stuck in place.

F1.1	Fault	Cooler Fan Fault input received	The cooler fan input to the controller has faulted and the cooler fan could have issues with wiring or cables from the control box to the fan.	Check wiring and all circuits from the fan to the controller or terminal blocks in the control box are connected properly and there are no loose wires or connectors. Depending on the results of the findings, replace the fan motor if needed or contact Gardner Denver service.
VFD Cooling Alarms				
FV1.1	Warning	VFD Cooling Over Current Warning	VFD is measuring excessive current to the motor. Motor current is approaching the fault limit to run the compressor.	Check wiring between fan motor and VFD for incorrect or loose connections. Verify supply voltage within tolerance. Check fan wheel for proper alignment and balance. If possible, manually spin fan wheel and observe rotation. Test fan motor insulation resistance.
FV1.1	Fault	VFD Cooling Over Current Fault	VFD is measuring excessive current to the motor, current has surpassed maximum fault level.	Check wiring between fan motor and VFD for incorrect or loose connections. Verify supply voltage within tolerance. Check fan wheel for proper alignment and balance. If possible, manually spin fan wheel and observe rotation. Test fan motor insulation resistance.
FV1.2	Warning	VFD Cooling Over Voltage Warning	VFD has detected that the DC bus voltage has risen above the warning limit, due to motor regen or high input voltage	Verify supply voltage within tolerance. Check if fan wheel is freewheeling when not running. Fan deceleration may be too fast and require parameter adjustment, contact Gardner Denver service.
FV1.2	Fault	VFD Cooling Over Voltage Fault	VFD has detected that the DC bus voltage has risen above the fault limit, due to motor regen or high input voltage	Verify supply voltage within tolerance. Check if fan wheel is freewheeling when not running. Fan deceleration may be too fast and require parameter adjustment, contact Gardner Denver service.
FV1.3	Warning	VFD Cooling Earth Warning	The VFD has detected a high level of ground current.	Check wiring between motor and VFD for incorrect or loose connections. Ground connections should be checked to make sure there is a solid connection. Inspect motor leads and conduit for damage or wear. Test motor insulation resistance.
FV1.3	Fault	VFD Cooling Earth Fault	The VFD has detected a high level of ground current.	Check wiring between motor and VFD for incorrect or loose connections. Ground connections should be checked to make sure there is a solid connection. Inspect motor leads and conduit for damage or wear. Test motor insulation resistance.
FV1.5	Fault	VFD Cooling Charging Circuit switch fault	The VFD has detected that the charging circuit has faulted.	Verify package supply voltage within tolerance. Check DC bus voltage with meter to verify voltage level (approx. 1.414 times AC Rms input voltage). Reset and restart compressor. If issue persists contact Gardner Denver service.
FV1.6	Fault	VFD Cooling Emergency Stop fault	Emergency Stop Pressed. E-Stop digital input signal received.	Reset the E-Stop switch. Refer to machine schematic and check wiring between E-Stop contact and cooling VFD input.
FV1.7	Fault	VFD Cooling Saturation Trip fault	Voltage across drive IGBT exceeds fault limit.	Verify package supply voltage within tolerance. Confirm DC bus voltage within tolerance when idle and running. Contact Gardner Denver service.
FV1.9	Warning	VFD Cooling Under Voltage Warning	Low VFD input voltage resulting in Low DC Bus voltage. Below the warning limit, nearing fault level.	Verify package supply voltage within tolerance. Check input wiring connections to VFD. Confirm DC bus voltage within tolerance when idle and running.

FV1.9	Fault	VFD Cooling Under Voltage Fault	Low VFD input voltage resulting in Low DC Bus voltage. Below the fault level.	Verify package supply voltage within tolerance. Check input wiring connections to VFD. Confirm DC bus voltage within tolerance when idle and running.
FV1.10	Fault	VFD Cooling Input Phase Fault	Input phase imbalance or phase loss in VFD supply	Check L-L voltage between all three phases supplying VFD input. Investigate configuration of 3 phase system supplying compressor package, protection may need to be disabled. Contact Gardner Denver service.
FV1.11	Fault	VFD Cooling Output Phase Fault	VFD has detected output phase loss to motor	Check wiring between motor and VFD for damaged or loose connections. Measure output current on the leads to the fan motor with a clamp on amp meter. Test motor insulation resistance.
FV1.13	Warning	VFD Cooling Drive Under Temp Warning	Ambient temperature is below the warning limit for the VFD	Raise ambient temperature near the VFD and compressor package.
FV1.13	Fault	VFD Cooling Drive Under Temp Fault	Ambient temperature is below the fault limit for the VFD	Raise ambient temperature near the VFD and compressor package.
FV1.14	Warning	VFD Cooling Drive Over Temp Warning	VFD is measuring internal temperatures above the warning limit.	Confirm ambient temperature near the VFD is below 50C. Check ventilation filters and fans mounted in the control panel for debris. Check the VFD heat sink cooling fans for correct operation. Clean cooling fans and heat sink fins with compressed air.
FV1.14	Fault	VFD Cooling Drive Over Temp Fault	VFD is measuring internal temperatures above the fault limit.	Confirm ambient temperature near the VFD is below 50C. Check ventilation filters and fans mounted in the control panel for debris. Check the VFD heat sink cooling fans for correct operation. Clean cooling fans and heat sink fins with compressed air.
FV1.15	Fault	VFD Cooling Motor Stall Fault	Motor has stalled during start or run	Check wiring between fan motor and VFD for incorrect or loose connections. Verify supply voltage within tolerance. Check fan wheel for proper alignment and balance. If possible, manually spin fan wheel and observe rotation. Test fan motor insulation resistance.
FV1.15	Warning	VFD Cooling Motor Stall Warning	Motor has stalled during start or run	Check wiring between fan motor and VFD for incorrect or loose connections. Verify supply voltage within tolerance. Check fan wheel for proper alignment and balance. If possible, manually spin fan wheel and observe rotation. Test fan motor insulation resistance.
FV1.16	Warning	VFD Cooling Motor Over Temp Warning	VFD has calculated that the motor has been run in an overloaded condition for an extended time and is too	Check wiring between motor and VFD for incorrect or loose connections. Check drive system for proper alignment and wear. Verify supply voltage within tolerance. Decouple compressor from drive motor and check for proper manual rotation. Test motor insulation resistance.
FV1.16	Fault	VFD Cooling Motor Over Temp Fault	VFD has calculated that the motor has been run in an overloaded condition for an extended time and is too	Check wiring between motor and VFD for incorrect or loose connections. Check drive system for proper alignment and wear. Verify supply voltage within tolerance. Decouple compressor from drive motor and check for proper manual rotation. Test motor insulation resistance.

FV1.19	Fault	VFD Cooling Power Board EEPROM fault	VFD has detected internal memory error.	Power cycle drive. Contact Gardner Denver service.
FV1.20	Fault	VFD Cooling RAM fault	VFD has detected internal memory error.	Power cycle drive. Contact Gardner Denver service.
FV1.21	Warning	VFD Cooling Serial Flash Warning	VFD has detected internal memory error.	Power cycle drive. Contact Gardner Denver service.
FV1.21	Fault	VFD Cooling Serial Flash Fault	VFD has detected internal memory error.	Power cycle drive. Contact Gardner Denver service.
FV1.25	Fault	VFD Cooling MCU Watchdog fault	VFD has detected internal processing error.	Power cycle drive. Contact Gardner Denver service.
FV1.32	Fault	VFD Cooling Fan Cooling fault	VFD has detected an issue with its heat sink cooling fans	Monitor the heat sink cooling fan operation. Using a multi-meter check for 24VDC/48VDC at the cooling fan pins during run (dependent on VFD size). Replace cooling fans as needed.
FV1.36	Fault	VFD Cooling Device Compatibility fault	VFD has detected and compatibility error between its control board and power board.	Power cycle drive. Contact Gardner Denver service.
FV1.37	Warning	VFD Cooling Device Changed warning	VFD has detected new option card or control board hardware	Power cycle drive. Contact Gardner Denver service.
FV1.38	Warning	VFD Cooling Device Added warning	VFD has detected a new option card has been installed	Power cycle drive. Contact Gardner Denver service.
FV1.39	Fault	VFD Cooling Device Removed fault	VFD has detected removal of an Option card	Power cycle drive. Contact Gardner Denver service.
FV1.40	Fault	VFD Cooling Unknown Device fault	VFD has detected and compatibility error between its control board and an option board.	Power down drive. Check option card and ribbon cable are connected.
FV1.41	Fault	VFD Cooling IGBT Temp fault	VFD has detected that IGBT internal temperatures are too high, potentially caused by high motor current	Check motor operating current at full load is not exceeding nominal rating. Check wiring between fan motor and VFD for incorrect or loose connections. Verify supply voltage within tolerance. Check fan wheel for proper alignment and balance. If possible, manually spin fan wheel and observe rotation. Test fan motor insulation resistance.
FV1.51	Warning	VFD Cooling External Input Warning	VFD has detected external fault input active	Check for any damage in external cable/wirings and check if there is any loose connections or terminal.
FV1.51	Fault	VFD Cooling External Input Fault	VFD has detected external fault input active	Check for any damage in external cable/wirings and check if there is any loose connections or terminal.
FV1.55	Warning	VFD Cooling Real Time Clock warning	VFD reporting error with the real time clock	Power cycle drive, Contact Gardner Denver service
FV1.55	Fault	VFD Cooling Real Time Clock Fault	VFD reporting error with the real time clock	Power cycle drive, Contact Gardner Denver service
FV1.58	Fault	VFD Cooling Current Measure fault	VFD has detected an error with its internal current measuring devices	Power cycle drive, Contact Gardner Denver service

FV1.59	Fault	VFD Cooling Power Wiring fault	Input/Output wiring to VFD is incorrectly connected	Power the drive down and safely lock out system. Inspect and verify input power wires are properly connected to VFD terminals L1/L2/L3. Inspect and verify motor leads are connected to the VFD output terminals U/V/W.
FV1.60	Fault	VFD Cooling control Board Over Temp fault	VFD is measuring control board temperatures above the fault limit.	Confirm ambient temperature near the VFD is below 50C. Check ventilation filters and fans mounted in the control panel for debris. If equipped, confirm the small control board cooling fan is operational.
FV1.61	Fault	VFD Cooling internal control Power Supply fault	VFD is reporting that the internal 24VDC control supply outside the range of 18-27VDC	Using a multi-meter, measure 24VDC supply at the control board terminals. If the voltage is in range, power cycle the drive. If out of range, contact Gardner Denver service.
FV1.62	Fault	VFD Cooling Flying Start fault	VFD has detected a failure during a flying start of the fan motor.	Check the VFD output terminal connections to the motor. Check if fan wheel is freewheeling in the wrong direction during start. Remove ventilation ducting causing the reverse freewheeling.
FV1.63	Fault	VFD Cooling Current Imbalance fault	The VFD has detected an output phase imbalance of more than 20%	Check VFD output terminal connections to the motor. Check the condition of the motor leads, and the connections in the motor junction box. Measure current with a clamp on amp meter in each lead between the VFD & motor. Test fan motor insulation resistance.
FV1.64	Warning	VFD Cooling Replace Battery Warning	The VFD's real time clock battery is near depletion	Replace the RTC battery.
FV1.64	Fault	VFD Cooling Replace Battery Fault	The VFD's real time clock battery is depleted	Replace the RTC battery.
FV1.65	Warning	VFD Cooling Replace Fan Warning	VFD has calculated that its cooling fan life is less than 2 months.	Inspect condition and operation of heat sink cooling fans. Replace as needed.
FV1.65	Fault	VFD Cooling Replace Fan Fault	VFD has calculated that its cooling fan life is less than 2 months.	Inspect condition and operation of heat sink cooling fans. Replace as needed.
FV1.66	Warning	VFD Cooling Safe Torque Off Warning	Emergency Stop Pressed. E-Stop digital input signal received.	Reset the E-Stop switch. Refer to machine schematic and check wiring between E-Stop contact and cooling VFD input.
FV1.66	Fault	VFD Cooling Safe Torque Off Fault	Emergency Stop Pressed. E-Stop digital input signal received.	Reset the E-Stop switch. Refer to machine schematic and check wiring between E-Stop contact and cooling VFD input.
FV1.67	Warning	VFD Cooling Current Limit Warning	VFD is actively limiting output current to the cooling fan motor, motor is overloaded	Check wiring between fan motor and VFD for incorrect or loose connections. Verify supply voltage within tolerance. Check fan wheel for proper alignment and balance. If possible, manually spin fan wheel and observe rotation. Test fan motor insulation resistance.
FV1.68	Warning	VFD Cooling Voltage Limit Warning	VFD has detected that the DC bus voltage has risen above the warning limit, due to motor regen or high input voltage	Verify supply voltage within tolerance. Check if fan wheel is freewheeling when not running. Fan deceleration may be too fast and require parameter adjustment, contact Gardner Denver service.
FV1.69	Fault	VFD Cooling System Fault	Internal communication error within the VFD	Try performing a power cycle to see if fault clears. Contact Gardner Denver service
FV1.83	Fault	VFD Cooling Communications fault	VFD has detected an error in the Modbus RTU communication between	Check the communication cabling between the controller and the VFD. Confirm proper cable routing (avoiding parallel runs with AC power

			it and the compressor controller	lines), and confirm cable shielding drains are terminated to ground terminals.
FV1.96	Warning	VFD Cooling Parameter Warning	Internal parameter error within the VFD	Try performing a power cycle to see if fault clears. Contact Gardner Denver service
FV1.96	Fault	VFD Cooling Parameter Fault	Internal parameter error within the VFD	Try performing a power cycle to see if fault clears. Contact Gardner Denver service
FV1.104	Warning	VFD Cooling Firmware Warning	Internal firmware compatibility error within the VFD	Try performing a power cycle to see if fault clears. Contact Gardner Denver service
FV1.104	Fault	VFD Cooling Firmware Fault	Internal firmware compatibility error within the VFD	Try performing a power cycle to see if fault clears. Contact Gardner Denver service
IC Alarms				
IC.10	Information	Data recording completed successfully	Informational alarm only. Data has successfully been written to the iConn device. This notification will not occur during normal operation.	No Action Required.
IC.11	Warning	Data recording interrupted	An error occurred in the operation attempting to write data to the iConn device. The operation may have been interrupted.	Check the USB cable connection to the iConn device and power cabling to the iConn. If the problem persists contact Gardner Denver service.
IC.12	Warning	Value of a registered process variable has violated limits	Internal software configuration issue.	Reboot the controller. If the problem persists, export the logs from the controller and contact Gardner Denver service.
Motor Alarms				
M1.0	Fault	Motor Auxiliary fault	The motor contactor or contactor coil has failed. The wiring to the contactor coil or aux contact has failed.	Check wiring to the contactor coil and auxiliary contact. Use the digital output IO diagnostics function in the controller to check operation of the contactor. If the contactor is not operating properly use an ohm-meter to check the resistance on the coil of the contactor.
M1.1	Fault	Motor Fault	The overload relay for the main motor has tripped.	Verify the motor connections, check the overload relay settings to make sure it matches the motor nameplate, and verify the wiring to the fault contact. Run the machine and record the amp draw of the motor, if the amp draw is higher than expected check the machine for any service needs. Check the line voltage supplied to the machine to ensure it is within the machine's rated voltage.
M1.2	Fault	Motor Temperature PTC Fault	The PTC internal to the motor windings has exceeded the resistance limit. The motor windings have exceeded the maximum temperature rating. The connection to the PTC device has failed.	Check the wiring to the motor PTC sensor. Using the IO diagnostics temperature page, evaluate the resistance of the motor PTC input. If the motor is cool the resistance should be low (less than 1kohm). The input will trip as resistance exceeds 3.4kohms. Evaluate if the motor is overheating, check for excessive load or damage to the motor or its cooling source.

M1.6	Warning	Motor High Current Warning	The motor current has exceeded the service factor amps and the controller has not been able to reduce load to control the current level.	Check that the motor service factor amps setting matches the motor nameplate. Run the machine and record the amp draw of the motor, if the amp draw is higher than expected check the machine for any service needs. Check the line voltage supplied to the machine to ensure it is within the machine's rated voltage.
M1.7	Fault	Motor Current Short fault	Motor Current sensor is faulty or the wiring to the sensor is shorted.	Using the wiring schematic for the machine, locate the motor current sensor connection to the controller. Check for any shorted wires at the connector. Inspect the cable for damage between the controller and the sensor. Replace or repair the wiring or sensor depending on the results of the findings.
M1.8	Fault	Motor Current Open fault	Motor current sensor is faulty, the wiring to the sensor is broken, or the wiring or connector is disconnected.	Using the wiring schematic for the machine, locate the motor current sensor connection to the controller. Check for disconnected wires, plugs, or loose connections. Inspect the cable for damage between the controller and the sensor. Replace or repair the wiring or sensor depending on the results of the findings.
M1.13	Fault	VFD Motor Speed Low fault	VFD Actual Motor Speed is below the minimum speed limit set in the controller.	Typically this alarm will be accompanied by a VFD warning or fault. See the actions for the associated VFD alarm. Contact Gardner Denver service.
M1.13	Warning	VFD Motor Speed Low warning	VFD Actual Motor Speed is below the minimum speed limit set in the controller.	Typically this alarm will be accompanied by a VFD warning or fault. See the actions for the associated VFD alarm. Contact Gardner Denver service.
M1.14	Fault	VFD Motor Speed High fault	VFD Actual Motor Speed is above the maximum speed limit set in the controller.	Typically this alarm will be accompanied by a VFD warning or fault. See the actions for the associated VFD alarm. Contact Gardner Denver service.
M1.14	Warning	VFD Motor Speed High warning	VFD Actual Motor Speed is above the maximum speed limit set in the controller.	Typically this alarm will be accompanied by a VFD warning or fault. See the actions for the associated VFD alarm. Contact Gardner Denver service.
Package Alarms				
P.0	Warning	Power Loss Warning	The controller has detected a power loss on the machine with auto restart enabled.	Reset the alarm
P.0	Fault	Power loss fault	The controller has detected a power loss on the machine with auto restart disabled. The controller has detected a power loss on the machine with auto restart enabled and max power loss time exceeded.	Reset the alarm
P.1	Fault	Emergency Stop fault	The emergency stop pushbutton has been activated on the machine.	When safe to do so, reset the E-stop pushbutton.

P.2	Fault	Low DC supply Voltage fault	Control panel 24VDC power supply has dropped below the low DC voltage fault limit.	Refer to the compressor package wiring diagram. Using a multi-meter, measure 24VDC supply at the power supply output terminals. If voltage is low, use the adjustment screw to raise voltage to 24VDC. If voltage is not present check for AC supply on the input side of the power supply. Check fuses protecting the AC supply to the DC power supply. Replace fuses or DC power supply as needed.
P.3	Fault	Low Sump Pressure Fault	Reservoir pressure has dropped below the low sump pressure fault level during operation.	Inspect blowdown and inlet valve control circuits for leaks. Confirm proper setting of blowdown adjustment device, if equipped.
P.4	Warning	Design Pressure Warning	During sequencing operation the plant delivery pressure has exceeded the unload pressure by 1bar (14.5psi).	Inspect process air piping downstream of compressor package for blockages or closed process valves. Check aftercooler for blockages. Confirm adequate air storage for compressor system.
P.5	Fault	No Start Pressure Fault	Controller did not detect proper pressure build-up during start.	Check for proper direction of rotation of airend. Check condition of minimum pressure valve.
P.6	Fault	Heavy Startup Fault	Reservoir pressure exceeded the heavy start-up fault limit during start-up.	Inspect inlet valve assembly for leaks and proper sealing during startup. Confirm proper adjustment of control pressure regulator if equipped.
P.7	Warning	Ambient temperature speed limiter warning	Ambient temperature is above the limiter set point.	Lower ambient temperature in compressor package area.
P.8	Warning	Control box temperature limiter warning	Control panel internal air temperature above the limiter set point.	Confirm ambient temp near the compressor package inlets is below the rating of the machine. Check ventilation filters and fans mounted in the control panel for debris, clean/replace as needed.
P.9	Warning	Cold start speed limiter warning	Ambient temperature is below the limiter set point.	Raise ambient temperature in compressor package area.
P.10	Warning	Voltage factor limiter warning	Package input voltage is below the tolerance of the compressor package. The motor is overloaded causing the VFD's DC Bus voltage to fall below the limiter set point.	Check wiring between motor and VFD for incorrect or loose connections. Verify supply voltage within tolerance. Check drive system for proper alignment and wear. Decouple compressor from drive motor and check for proper manual rotation. Test motor insulation resistance.
P.11	Warning	Drive current speed limiter active	VFD output current is above the limiter set point. Motor is overloaded.	Check wiring between motor and VFD for incorrect or loose connections. Verify supply voltage within tolerance. Check drive system for proper alignment and wear. Decouple compressor from drive motor and check for proper manual rotation. Test motor insulation resistance.
P.12	Warning	Heatsink temperature limiter warning	VFD heatsink temperature is above the limiter set point.	Confirm ambient temperature near the VFD is below 50C. Check ventilation filters and fans mounted in the control panel for debris. Check the VFD heat sink cooling fans for correct operation. Clean cooling fans and heat sink fins with compressed air.
P.21	Warning	Low voltage relay warning	Programmable input for low voltage relay warning	Inspect low voltage relay and monitor for conditions causing the device to trip.

			function has been activated.	
P.21	Fault	Low voltage relay fault	Programmable input for low voltage relay fault function has been activated.	Inspect low voltage relay and monitor for conditions causing the device to trip.
P.22	Fault	High vibration fault	Programmable input for high vibration fault function has been activated.	Inspect vibration monitoring equipment and correct issue causing high vibration.
P.22	Warning	High vibration warning	Programmable input for high vibration warning function has been activated.	Inspect vibration monitoring equipment and correct issue causing high vibration.
P.23	Fault	Enclosure temp fault	Programmable input for high package enclosure temp fault has been activated.	Check the site conditions and decrease ambient temperature around the package enclosure.
P.24	Fault	Belt break fault	Programmable input for belt break fault has been activated.	Inspect drive belt, replace as necessary
P.25	Fault	Safety switch fault	Programmable input for safety switch fault has been activated.	Inspect the switch and correct conditions causing it to trip.
P.26	Fault	Oil Level 1 fault	Programmable input for oil level 1 fault has been activated.	Inspect oil level and condition. Add oil as necessary.
P.26	Fault	Oil Level 1 warning	Programmable input for oil level 1 warning has been activated.	Inspect oil level and condition. Add oil as necessary.
P.27	Fault	Oil level 2 fault	Programmable input for oil level 2 fault has been activated.	Inspect oil level and condition. Add oil as necessary.
P.27	Fault	Oil level 2 warning	Programmable input for oil level 2 warning has been activated.	Inspect oil level and condition. Add oil as necessary.
P.29	Fault	User Shutdown Fault input received : External Device	The digital input programmed for an external fault has been activated.	Inspect the external device.
P.29	Warning	External Warning	The digital input programmed for an external warning has been activated.	Inspect the external device.
P.30	Fault	Dryer Fault	The digital input programmed for dryer fault has been activated.	Inspect the dryer and dryer control system if equipped.
P.100	Fault	Separator temperature rate fault	Separator temperature has increased at a rate above the rate-of-rise fault limit.	Check the condition of compressor cooling functions such as thermal mixing valve and cooler. Check oil condition and oil level. Examine airend for issues. Review history of compressor discharge temperature using the controller trends, data logs, or site maintenance log. Perform adjustments, cleaning, or repair based on the results of the investigation.

P.101	Fault	separator temperature high fault	Separator temperature has exceeded the high fault limit setting.	Check the condition of compressor cooling functions such as thermal mixing valve and cooler. Check oil condition and oil level. Examine airend for issues. Review history of compressor discharge temperature using the controller trends, data logs, or site maintenance log. Perform adjustments, cleaning, or repair based on the results of the investigation.
P.101	Warning	separator temperature high warning	Separator temperature has exceeded the high warning limit, nearing the fault limit.	Check the condition of compressor cooling functions such as thermal mixing valve and cooler. Check oil condition and oil level. Examine airend for issues. Review history of compressor discharge temperature using the controller trends, data logs, or site maintenance log. Perform adjustments, cleaning, or repair based on the results of the investigation.
P.102	Fault	separator temperature low fault	Separator temperature is below the low fault limit setting.	Increase the ambient temperature near the inlet to the compressor package.
P.102	Warning	separator temperature low warning	Separator temperature is below the low warning limit, nearing the fault limit.	Increase the ambient temperature near the inlet to the compressor package.
P.103	Fault	separator temperature short fault	Separator temperature sensor is faulty, or the wiring to the sensor is shorted.	Using the wiring schematic for the machine, locate the separator temperature sensor connection to the controller. Check for any shorted wires at the connector. Inspect the cable for damage between the controller and the sensor. Remove the cable connector from the sensor and use a multi-meter to check the resistance of the sensor and ensure that it is not shorted. It is possible that the sensor may read within range at room temperature but still be faulty once exposed to an elevated temperature or vibration. Replace or repair the wiring or sensor as needed.
P.104	Fault	separator temperature open fault	Separator temperature sensor is faulty, or the connection between the sensor and controller is disconnected.	Using the wiring schematic for the machine, locate the separator temperature sensor connection to the controller. Check for disconnected wires, plugs, or loose connections. Inspect the cable for damage between the controller and the sensor. Remove the cable connector from the sensor and use a multi-meter to check the resistance of the sensor and ensure that it is not open (very high resistance) It is possible that the sensor may read within range at room temperature but still be faulty once exposed to an elevated temperature or vibration. Replace or repair the wiring or sensor as needed.
P.105	Fault	Ambient temperature high fault	Ambient air temperature is too high to start or run the compressor.	Check the site conditions and decrease temperature of the ambient air to the compressor enclosure.
P.105	Warning	Ambient temperature high warning	Ambient air temperature is approaching the maximum limit to start or run the compressor.	Check the site conditions and decrease temperature of the ambient air to the compressor enclosure.
P.106	Fault	Ambient temperature low fault	Ambient air temperature is too low to start or run the compressor.	Check the site conditions and increase temperature of the ambient air to the compressor enclosure.

P.106	Warning	Ambient temperature low warning	Ambient air temperature is approaching the minimum limit to start or run the compressor.	Check the site conditions and increase temperature of the ambient air to the compressor enclosure.
P.107	Fault	Ambient temperature short fault	Ambient temperature sensor is faulty or the wiring to the sensor is shorted.	Using the wiring schematic for the machine, locate the enclosure temperature sensor connection to the controller. Check for any shorted wires at the connector. Inspect the cable for damage between the controller and the sensor. Remove the cable connector from the sensor and use a multi-meter to check the resistance of the sensor and ensure that it is not shorted. It is possible that the sensor may read within range at room temperature but still be faulty once exposed to an elevated temperature or vibration. Replace or repair the wiring or sensor depending on the results of the findings.
P.108	Fault	Ambient temperature open fault	Ambient temperature sensor is faulty, the wiring to the sensor is broken, or the wiring or connector is disconnected.	Using the wiring schematic for the machine, locate the enclosure temperature sensor connection to the controller. Check for disconnected wires, plugs, or loose connections. Inspect the cable for damage between the controller and the sensor. Remove the cable connector from the sensor and use a multi-meter to check the resistance of the sensor and ensure that it is not open (very high resistance). It is possible that the sensor may read within range at room temperature but still be faulty once exposed to an elevated temperature or vibration. Replace or repair the wiring or sensor depending on the results of the findings.
P.110	Fault	Control Box temperature high fault	Control panel internal air temperature has exceeded the high fault limit.	Confirm ambient temp near the compressor package inlets is below the rating of the machine. Check ventilation filters and fans mounted in the control panel for debris, clean/replace as needed.
P.110	Warning	Control Box temperature high warning	Control panel internal air temperature is approaching the maximum limit to start or run the compressor.	Confirm ambient temp near the compressor package inlets is below the rating of the machine. Check ventilation filters and fans mounted in the control panel for debris, clean/replace as needed.
P.111	Fault	Control Box temperature low fault	Control panel internal air temperature is below the low fault limit.	Check the site conditions and increase the ambient temperature of the air near the compressor package.
P.111	Warning	Control Box temperature low warning	Control Box air temperature is approaching the minimum limit to start or run the compressor.	Check the site conditions and increase the ambient temperature of the air near the compressor package.
P.112	Fault	Control Box temperature short fault	Control Box temperature sensor is faulty or the wiring to the sensor is shorted.	Using the wiring schematic for the machine, locate the Control Box temperature sensor connection. Check for any shorted wires at the connector. Inspect the cable for damage between the controller and the sensor. Remove the cable connector from the sensor and use a multi-meter to check the resistance of the sensor and ensure that it is not shorted. It is possible that the sensor may read within range at room temperature but still be faulty once exposed to an elevated temperature or vibration. Replace or repair the

				wiring or sensor depending on the results of the findings.
P.113	Fault	Control Box temperature open fault	Control Box temperature sensor is faulty, the wiring to the sensor is broken, or the wiring or connector is disconnected.	Using the wiring schematic for the machine, locate the Control Box temperature sensor connection. Check for disconnected wires, plugs, or loose connections. Inspect the cable for damage between the controller and the sensor. Remove the cable connector from the sensor and use a multi-meter to check the resistance of the sensor and ensure that it is not open (very high resistance). It is possible that the sensor may read within range at room temperature but still be faulty once exposed to an elevated temperature or vibration. Replace or repair the wiring or sensor depending on the results of the findings.
P.114	Fault	Plant delivery temperature rate fault	Plant delivery temperature has increased at a rate above the rate-of-rise fault limit.	Inspect the aftercooler and cooling fan for proper operation. Clean the aftercooler if required.
P.115	Fault	Plant delivery temperature high fault	Plant delivery air temperature has exceeded the high fault limit.	Inspect the aftercooler and cooling fan for proper operation. Clean the aftercooler if required.
P.115	Warning	Plant delivery temperature high warning	Plant delivery air temperature is approaching the high fault limit.	Inspect the aftercooler and cooling fan for proper operation. Clean the aftercooler if required.
P.116	Fault	Plant delivery temperature low fault	Plant delivery air temperature is below the low fault limit.	Check the site conditions and increase the ambient temperature near the compressor package.
P.116	Warning	Plant delivery temperature low warning	Plant delivery air temperature is approaching the low fault limit.	Check the site conditions and increase the ambient temperature near the compressor package.
P.117	Fault	Plant delivery temperature short fault	Delivery temperature sensor is faulty or the wiring to the sensor is shorted.	Using the wiring schematic for the machine, locate the Delivery temperature sensor connection to the controller. Check for any shorted wires at the connector. Inspect the cable for damage between the controller and the sensor. Remove the cable connector from the sensor and use a multi-meter to check the resistance of the sensor and ensure that it is not shorted. It is possible that the sensor may read within range at room temperature but still be faulty once exposed to an elevated temperature or vibration. Replace or repair the wiring or sensor depending on the results of the findings.

P.118	Fault	Plant delivery temperature open fault	Delivery temperature sensor is faulty, the wiring to the sensor is broken, or the wiring or connector is disconnected.	Using the wiring schematic for the machine, locate the Delivery temperature sensor connection to the controller. Check for disconnected wires, plugs, or loose connections. Inspect the cable for damage between the controller and the sensor. Remove the cable connector from the sensor and use a multi-meter to check the resistance of the sensor and ensure that it is not open (very high resistance). It is possible that the sensor may read within range at room temperature but still be faulty once exposed to an elevated temperature or vibration. Replace or repair the wiring or sensor depending on the results of the findings.
P.120	Fault	Dryer temperature high fault	Dryer air temperature is too high to start or run the compressor.	Check the site conditions and decrease temperature of the dryer air temperature.
P.120	Warning	Dryer temperature high warning	Dryer air temperature is approaching the maximum limit to start or run the compressor.	Check the site conditions and decrease temperature of the dryer air temperature.
P.121	Fault	Dryer temperature low fault	Dryer air temperature is too low to start or run the compressor.	Check the site conditions and increase temperature of the dryer air temperature.
P.121	Warning	Dryer temperature low warning	Dryer air temperature is approaching the minimum limit to start or run the compressor.	Check the site conditions and increase temperature of the dryer air temperature.
P.122	Fault	Dryer temperature short fault	Dryer temperature sensor is faulty or the wiring to the sensor is shorted.	Using the wiring schematic for the machine, locate the Dryer temperature sensor connection to the controller. Check for any shorted wires at the connector. Inspect the cable for damage between the controller and the sensor. Remove the cable connector from the sensor and use a multi-meter to check the resistance of the sensor and ensure that it is not shorted. It is possible that the sensor may read within range at room temperature but still be faulty once exposed to an elevated temperature or vibration. Replace or repair the wiring or sensor depending on the results of the findings.
P.123	Fault	Dryer temperature open fault	Dryer temperature sensor is faulty, the wiring to the sensor is broken, or the wiring or connector is disconnected.	Using the wiring schematic for the machine, locate the Dryer temperature sensor connection to the controller. Check for disconnected wires, plugs, or loose connections. Inspect the cable for damage between the controller and the sensor. Remove the cable connector from the sensor and use a multi-meter to check the resistance of the sensor and ensure that it is not open (very high resistance). It is possible that the sensor may read within range at room temperature but still be faulty once exposed to an elevated temperature or vibration. Replace or repair the wiring or sensor depending on the results of the findings.
P.129	Fault	Oil Sump 1 temperature rate fault	Oil Sump 1 temperature is increasing at a rate above the rate-of-rise fault limit.	Inspect the oil level and condition. Add oil as required. Inspect the oil cooler and thermal mixing valve operation. Clean the cooler as required.

P.130	Fault	Oil Sump 1 temperature high fault	Oil Sump 1 temperature has exceeded the high temp fault limit.	Inspect the oil level and condition. Add oil as required. Inspect the oil cooler and thermal mixing valve operation. Clean the cooler as required.
P.130	Warning	Oil Sump 1 temperature high warning	Oil Sump 1 temperature has exceeded the high temp warning limit and is approaching the fault limit.	Inspect the oil level and condition. Add oil as required. Inspect the oil cooler and thermal mixing valve operation. Clean the cooler as required.
P.131	Fault	Oil Sump 1 temperature low fault	Oil Sump 1 temperature is too low to start or run the compressor.	Raise the ambient temperature with the compressor package. Inspect thermal mixing valve.
P.131	Warning	Oil Sump 1 temperature low warning	Oil Sump 1 temperature is approaching the minimum limit to start or run the compressor.	Raise the ambient temperature with the compressor package. Inspect thermal mixing valve.
P.132	Fault	Oil Sump 1 temperature short fault	Oil Sump 1 temperature sensor is faulty or the wiring to the sensor is shorted.	Using the wiring schematic for the machine, locate the Oil Sump 1 temperature sensor connection to the controller. Check for any shorted wires at the connector. Inspect the cable for damage between the controller and the sensor. Remove the cable connector from the sensor and use a multi-meter to check the resistance of the sensor and ensure that it is not shorted. It is possible that the sensor may read within range at room temperature but still be faulty once exposed to an elevated temperature or vibration. Replace or repair the wiring or sensor depending on the results of the findings.
P.133	Fault	Oil Sump 1 temperature open fault	Oil Sump 1 temperature sensor is faulty, the wiring to the sensor is broken, or the wiring or connector is disconnected.	Using the wiring schematic for the machine, locate the Oil Sump 1 temperature sensor connection to the controller. Check for disconnected wires, plugs, or loose connections. Inspect the cable for damage between the controller and the sensor. Remove the cable connector from the sensor and use a multi-meter to check the resistance of the sensor and ensure that it is not open (very high resistance). It is possible that the sensor may read within range at room temperature but still be faulty once exposed to an elevated temperature or vibration. Replace or repair the wiring or sensor depending on the results of the findings.
P.134	Fault	Oil Sump 2 temperature rate fault	Oil Sump 2 temperature is increasing at a rate above the rate-of-rise fault limit.	Inspect the oil level and condition. Add oil as required. Inspect the oil cooler and thermal mixing valve operation. Clean the cooler as required.
P.135	Fault	Oil Sump 2 temperature high fault	Oil Sump 2 temperature has exceeded the high temp fault limit.	Inspect the oil level and condition. Add oil as required. Inspect the oil cooler and thermal mixing valve operation. Clean the cooler as required.
P.235	Warning	Oil Sump 2 temperature high warning	Oil Sump 2 temperature has exceeded the high temp warning limit and is approaching the fault limit.	Inspect the oil level and condition. Add oil as required. Inspect the oil cooler and thermal mixing valve operation. Clean the cooler as required.
P.236	Fault	Oil Sump 2 temperature low fault	Oil Sump 2 temperature is too low to start or run the compressor.	Raise the ambient temperature with the compressor package. Inspect thermal mixing valve.

P.236	Warning	Oil Sump 2 temperature low warning	Oil Sump 2 temperature is approaching the minimum limit to start or run the compressor.	Raise the ambient temperature with the compressor package. Inspect thermal mixing valve.
P.237	Fault	Oil Sump 2 temperature short fault	Oil Sump 2 temperature sensor is faulty or the wiring to the sensor is shorted.	Using the wiring schematic for the machine, locate the Oil Sump 2 temperature sensor connection to the controller. Check for any shorted wires at the connector. Inspect the cable for damage between the controller and the sensor. Remove the cable connector from the sensor and use a multi-meter to check the resistance of the sensor and ensure that it is not shorted. It is possible that the sensor may read within range at room temperature but still be faulty once exposed to an elevated temperature or vibration. Replace or repair the wiring or sensor depending on the results of the findings.
P.238	Fault	Oil Sump 2 temperature open fault	Oil Sump 2 temperature sensor is faulty, the wiring to the sensor is broken, or the wiring or connector is disconnected.	Using the wiring schematic for the machine, locate the Oil Sump 2 temperature sensor connection to the controller. Check for disconnected wires, plugs, or loose connections. Inspect the cable for damage between the controller and the sensor. Remove the cable connector from the sensor and use a multi-meter to check the resistance of the sensor and ensure that it is not open (very high resistance). It is possible that the sensor may read within range at room temperature but still be faulty once exposed to an elevated temperature or vibration. Replace or repair the wiring or sensor depending on the results of the findings.
P.139	Fault	Oil Injection Temperature rate fault	Oil injection temperature is increasing at a rate above the rate-of-rise fault limit.	Inspect the oil level and condition. Add oil as required. Inspect the oil cooler and thermal mixing valve operation. Clean the cooler as required.
P.140	Fault	Oil Injection temperature high fault	Oil injection temperature has exceeded the high temp fault limit.	Inspect the oil level and condition. Add oil as required. Inspect the oil cooler and thermal mixing valve operation. Clean the cooler as required.
P.140	Warning	Oil Injection temperature high warning	Oil injection temperature has exceeded the high temp warning limit and is approaching the fault limit.	Inspect the oil level and condition. Add oil as required. Inspect the oil cooler and thermal mixing valve operation. Clean the cooler as required.
P.141	Fault	Oil Injection temperature low fault	Oil Injection temperature is too low to start or run the compressor.	Raise the ambient temperature with the compressor package. Inspect thermal mixing valve.
P.141	Warning	Oil Injection temperature low warning	Oil Injection temperature is approaching the minimum limit to start or run the compressor.	Raise the ambient temperature with the compressor package. Inspect thermal mixing valve.
P.142	Fault	Oil Injection temperature short fault	Oil Injection temperature sensor is faulty or the wiring to the sensor is shorted.	Using the wiring schematic for the machine, locate the Oil Injection temperature sensor connection to the controller. Check for any shorted wires at the connector. Inspect the cable for damage between the controller and the sensor. Remove the cable connector from the sensor and use a multi-meter to check the resistance of the sensor and ensure that it is not shorted. It is possible that the sensor may read

				within range at room temperature but still be faulty once exposed to an elevated temperature or vibration. Replace or repair the wiring or sensor depending on the results of the findings.
P.143	Fault	Oil Injection temperature open fault	Oil Injection temperature sensor is faulty, the wiring to the sensor is broken, or the wiring or connector is disconnected.	Using the wiring schematic for the machine, locate the Oil Injection temperature sensor connection to the controller. Check for disconnected wires, plugs, or loose connections. Inspect the cable for damage between the controller and the sensor. Remove the cable connector from the sensor and use a multi-meter to check the resistance of the sensor and ensure that it is not open (very high resistance). It is possible that the sensor may read within range at room temperature but still be faulty once exposed to an elevated temperature or vibration. Replace or repair the wiring or sensor depending on the results of the findings.
P.159	Fault	Enclosure temperature rate fault	Enclosure temperature is increasing at a rate above the rate-of-rise fault limit.	Check the site conditions and decrease the ambient temperature in the compressor enclosure.
P.160	Fault	Enclosure temperature high fault	Enclosure temperature has exceeded the high temp fault limit.	Check the site conditions and decrease the ambient temperature in the compressor enclosure.
P.160	Warning	Enclosure temperature high warning	Enclosure temperature is approaching the high temp fault limit.	Check the site conditions and decrease the ambient temperature in the compressor enclosure.
P.161	Fault	Enclosure temperature low fault	Enclosure temperature is below the low temp fault limit.	Check the site conditions and increase the ambient temperature in the compressor enclosure.
P.161	Warning	Enclosure temperature low warning	Enclosure temperature is approaching the low temp fault limit.	Check the site conditions and increase the ambient temperature in the compressor enclosure.
P.162	Fault	Enclosure temperature short fault	Enclosure temperature sensor is faulty or the wiring to the sensor is shorted.	Using the wiring schematic for the machine, locate the Enclosure temperature sensor connection to the controller. Check for any shorted wires at the connector. Inspect the cable for damage between the controller and the sensor. Remove the cable connector from the sensor and use a multi-meter to check the resistance of the sensor and ensure that it is not shorted. It is possible that the sensor may read within range at room temperature but still be faulty once exposed to an elevated temperature or vibration. Replace or repair the wiring or sensor depending on the results of the findings.

P.163	Fault	Enclosure temperature open fault	Enclosure temperature sensor is faulty, the wiring to the sensor is broken, or the wiring or connector is disconnected.	Using the wiring schematic for the machine, locate the Enclosure temperature sensor connection to the controller. Check for disconnected wires, plugs, or loose connections. Inspect the cable for damage between the controller and the sensor. Remove the cable connector from the sensor and use a multi-meter to check the resistance of the sensor and ensure that it is not open (very high resistance). It is possible that the sensor may read within range at room temperature but still be faulty once exposed to an elevated temperature or vibration. Replace or repair the wiring or sensor depending on the results of the findings.
P.201	Fault	Plant Delivery pressure high fault	Plant delivery pressure has exceeded the high pressure fault limit.	Inspect process air piping downstream of compressor package for blockages or closed process valves. Check aftercooler for blockages. Confirm adequate air storage for compressor system.
P.201	Warning	Plant Delivery pressure high warning	Plant delivery pressure is approaching the high pressure fault limit.	Inspect process air piping downstream of compressor package for blockages or closed process valves. Check aftercooler for blockages. Confirm adequate air storage for compressor system.
P.202	Fault	Plant Delivery pressure short fault	Plant Delivery sensor is faulty or the wiring to the sensor is shorted.	Using the wiring schematic for the machine, locate the plant delivery pressure sensor connection to the controller. Check for any shorted wires at the connector. Inspect the cable for damage between the controller and the sensor. Using a multi-meter with process clamp meter measure the current (mA) in the signal wire between the sensor and controller. The signal should be in the range of 4-20mA. Replace or repair the wiring or sensor depending on the results of the findings.
P.203	Fault	Plant Delivery pressure open fault	Plant Delivery pressure sensor is faulty, the wiring to the sensor is broken, or the wiring or connector is disconnected.	Using the wiring schematic for the machine, locate the plant delivery pressure sensor connection to the controller. Check for disconnected wires, plugs, or loose connections. Inspect the cable for damage between the controller and the sensor. Using a multi-meter with process clamp meter measure the current (mA) in the signal wire between the sensor and controller. The signal should be in the range of 4-20mA. Replace or repair the wiring or sensor depending on the results of the findings.
P.204	Fault	Reservoir pressure high fault	Reservoir pressure has exceeded the high pressure fault limit.	Inspect inlet valve assembly for leaks and proper sealing during unloaded operation. Confirm proper adjustment of control pressure regulator if equipped. Confirm proper operation of the blowdown circuit. Check MPV for proper operation. Inspect aftercooler for blockages.
P.204	Warning	Reservoir pressure high warning	Reservoir pressure is approaching the high pressure fault limit.	Inspect inlet valve assembly for leaks and proper sealing during unloaded operation. Confirm proper adjustment of control pressure regulator if equipped. Confirm proper operation of the blowdown circuit. Check MPV for proper operation. Inspect aftercooler for blockages.

P.205	Fault	Reservoir pressure short fault	Reservoir pressure sensor is faulty or the wiring to the sensor is shorted.	Using the wiring schematic for the machine, locate the Reservoir pressure sensor connection to the controller. Check for any shorted wires at the connector. Inspect the cable for damage between the controller and the sensor. Using a multi-meter with process clamp meter measure the current (mA) in the signal wire between the sensor and controller. The signal should be in the range of 4-20mA. Replace or repair the wiring or sensor depending on the results of the findings.
P.206	Fault	Reservoir pressure open fault	Reservoir pressure sensor is faulty, the wiring to the sensor is broken, or the wiring or connector is disconnected.	Using the wiring schematic for the machine, locate the Reservoir pressure sensor connection to the controller. Check for disconnected wires, plugs, or loose connections. Inspect the cable for damage between the controller and the sensor. Using a multi-meter with process clamp meter measure the current (mA) in the signal wire between the sensor and controller. The signal should be in the range of 4-20mA. Replace or repair the wiring or sensor depending on the results of the findings.
P.207	Fault	Separator pressure high fault	Separator pressure has exceeded the high pressure fault limit.	Inspect inlet valve assembly for leaks and proper sealing during unloaded operation. Confirm proper adjustment of control pressure regulator if equipped. Confirm proper operation of the blowdown circuit. Check MPV for proper operation. Inspect aftercooler for blockages.
P.207	Warning	Separator pressure high warning	Separator pressure is approaching the high pressure fault limit.	Inspect inlet valve assembly for leaks and proper sealing during unloaded operation. Confirm proper adjustment of control pressure regulator if equipped. Confirm proper operation of the blowdown circuit. Check MPV for proper operation. Inspect aftercooler for blockages.
P.208	Fault	Separator pressure short fault	Separator pressure sensor is faulty or the wiring to the sensor is shorted.	Using the wiring schematic for the machine, locate the Separator pressure sensor connection to the controller. Check for any shorted wires at the connector. Inspect the cable for damage between the controller and the sensor. Using a multi-meter with process clamp meter measure the current (mA) in the signal wire between the sensor and controller. The signal should be in the range of 4-20mA. Replace or repair the wiring or sensor depending on the results of the findings.
P.209	Fault	Separator pressure open fault	Separator pressure sensor is faulty, the wiring to the sensor is broken, or the wiring or connector is disconnected.	Using the wiring schematic for the machine, locate the Separator pressure sensor connection to the controller. Check for disconnected wires, plugs, or loose connections. Inspect the cable for damage between the controller and the sensor. Using a multi-meter with process clamp meter measure the current (mA) in the signal wire between the sensor and controller. The signal should be in the range of 4-20mA. Replace or repair the wiring or sensor depending on the results of the findings.
P.210	Fault	System pressure high fault	The system pressure has exceeded the high pressure fault limit.	Inspect process air piping for blockages or closed process valves. Confirm adequate air storage for compressor system.
P.210	Warning	System pressure high warning	The system pressure is approaching the high pressure fault limit.	Inspect process air piping for blockages or closed process valves. Confirm adequate air storage for compressor system.

P.211	Fault	System pressure short fault	System pressure sensor is faulty or the wiring to the sensor is shorted.	Using the wiring schematic for the machine, locate the System pressure sensor connection to the controller. Check for any shorted wires at the connector. Inspect the cable for damage between the controller and the sensor. Using a multi-meter with process clamp meter measure the current (mA) in the signal wire between the sensor and controller. The signal should be in the range of 4-20mA. Replace or repair the wiring or sensor depending on the results of the findings.
P.212	Fault	System pressure open fault	System pressure sensor is faulty, the wiring to the sensor is broken, or the wiring or connector is disconnected.	Using the wiring schematic for the machine, locate the System pressure sensor connection to the controller. Check for disconnected wires, plugs, or loose connections. Inspect the cable for damage between the controller and the sensor. Using a multi-meter with process clamp meter measure the current (mA) in the signal wire between the sensor and controller. The signal should be in the range of 4-20mA. Replace or repair the wiring or sensor depending on the results of the findings.
P.225	Fault	Oil Injection pressure low fault	Oil injection pressure is below the low fault pressure limit.	Inspect the oil level and condition. Add oil as required. Inspect the oil cooler and thermal mixing valve operation. Confirm proper operation of the oil pump.
P.225	Warning	Oil Injection pressure low warning	Oil injection pressure is approaching the low fault pressure limit.	Inspect the oil level and condition. Add oil as required. Inspect the oil cooler and thermal mixing valve operation. Confirm proper operation of the oil pump.
P.226	Fault	Oil Injection pressure high fault	Oil injection pressure has exceeded the high pressure fault limit.	Inspect the oil system, pump, and cooler for blockages. Confirm proper operation of the oil pump.
P.226	Warning	Oil Injection pressure high warning	Oil injection pressure has exceeded the high pressure warning limit and is approaching the fault limit.	Inspect the oil system, pump, and cooler for blockages. Confirm proper operation of the oil pump.
P.227	Fault	Oil Injection pressure short fault	Oil Injection pressure sensor is faulty or the wiring to the sensor is shorted.	Using the wiring schematic for the machine, locate the Oil Injection pressure sensor connection to the controller. Check for any shorted wires at the connector. Inspect the cable for damage between the controller and the sensor. Replace or repair the wiring or sensor depending on the results of the findings.
P.228	Fault	Oil Injection pressure open fault	Oil Injection pressure sensor is faulty, the wiring to the sensor is broken, or the wiring or connector is disconnected.	Using the wiring schematic for the machine, locate the Oil Injection pressure sensor connection to the controller. Check for disconnected wires, plugs, or loose connections. Inspect the cable for damage between the controller and the sensor. Replace or repair the wiring or sensor depending on the results of the findings.
P.312	Warning	Remote speed control short fault	Remote speed control input is faulty or the wiring to the sensor is shorted.	Using the wiring schematic for the machine, locate the Remote speed control input connection to the controller. Check for any shorted wires at the connector. Inspect the cable for damage between the controller and the Remote speed control. Replace or repair the wiring or sensor depending on the results of the findings.

P.313	Warning	Remote speed control open fault	Remote speed control input is faulty, the wiring to the sensor is broken, or the wiring or connector is disconnected.	Using the wiring schematic for the machine, locate the Remote speed control input connection to the controller. Check for any shorted wires at the connector. Inspect the cable for damage between the controller and the Remote speed control. Replace or repair the wiring or sensor depending on the results of the findings.
Service Alarms				
S.0	Warning	Service Warning	The machine is due for servicing.	Perform the respective service task and reset the timer in the controller once the task is complete. Locate the Distributor info tab in the control settings to schedule a maintenance visit by a certified technician.
S.1	Warning	Air Filter maintenance warning	Air Filter Maintenance required. The service timer for the air filter has run out and the machine is due for servicing.	Change the air filter and reset the timer in the controller when the change is complete.
S.2	Warning	Oil Filter maintenance warning	Oil Filter Maintenance required. The service timer for the oil filter has run out and the machine is due for servicing.	Change the oil filter and reset the timer in the controller when the change is complete.
S.3	Warning	Oil change maintenance warning	Oil Change required. The service timer for the oil has run out and the machine is due for servicing.	Change the Oil in the machine following the service instructions. Reset the timer after the change is complete.
S.4	Warning	Oil sample maintenance warning	Oil Sample Service required. The service timer for taking an oil sample has expired.	Perform the Oil sample service following service instructions. Reset the timer in the controller once the change is complete.
S.5	Warning	Separator maintenance warning	Separator service required. The service timer for performing separator maintenance has expired.	Perform the Separator maintenance and reset the timer in the controller once the maintenance is complete
S.6	Warning	Motor Lubrication maintenance warning	Motor lubrication service required. The service timer for the motor lubrication has expired and it is time	Change the Motor Lubrication in the machine and reset the timer in the controller when the change is complete.
S.7	Warning	Control Box filter maintenance warning	Control box filter service required. The control box filter service timer has expired.	Change the control box air filter. Once a new air filter is installed, reset the timer in the controller.
S.8	Warning	Drive Belt maintenance warning	Drive belt service required. The service timer for drive belt maintenance has expired.	Perform the drive belt maintenance on the machine and reset the timer in the controller once complete.
S.9	Warning	Bearings greasing maintenance warning	Bearings greasing service required. The service timer for the bearings greasing service has expired.	Perform the Bearing greasing maintenance and reset the timer in the controller once the maintenance is complete.
S.10	Warning	Compressor overhaul	Compressor overhaul service required. The service timer for a	Perform the Compressor overhaul service on the machine and reset the service timer on the controller when complete.

		maintenance warning	compressor overhaul has expired.	
S.21	Warning	Air Filter Warning	The digital input for the air filter vacuum has tripped. The air filter is blocked and has created excessive vacuum at the inlet to the compressor	Change the air filter and reset the air filter maintenance timer when the change is complete.
S.22	Warning	Oil Filter Warning	The digital input for the oil filter differential pressure has tripped. The oil filter is blocked or defective.	Change the oil filter and reset the oil filter maintenance timer when the change is complete.
S.25	Warning	External maintenance warning	The digital input programmed for external maintenance warning has tripped.	Service the external device.
S.30	Fault	Change Separator fault	The differential pressure across the separator element has exceeded the fault limit. The separator element needs to be serviced.	Change the separator element and reset the separator maintenance timer when the change is complete.
S.30	Warning	Change Separator Warning	The differential pressure across the separator element has exceeded the warning limit. The separator element needs to be serviced.	Change the separator element and reset the separator maintenance timer when the change is complete.
Sequencing Alarms				
SQ.0	Warning	Sequencing communication error warning	Problem with the communication wiring or connection to the controller.	Check the cable and wiring connection to the controller or IO brick, depending on protocol, to verify no loose wires or connectors. Make sure each of the compressors in the sequence are wired properly and the controller sequencing settings are correct.
SQ.1	Warning	Sequencing duplicate unit number warning	The Unit number assigned in the sequencing menu is identical to another machine in the sequence.	Change the unit number in the sequencing settings menu of the device to an unused value, either the next number in the sequence or the missing number.
SQ.2	Warning	Sequencing no Compressor detected warning	No available compressors in sequence. Connection may have been disrupted between compressors.	Check the communication wiring from the master machine to each of the slaves to ensure connection is secure and there are no loose wires. Confirm the sequencing settings in the controller. Refer to the sequencing manual for more information. Power cycle controller if connections and settings are correct.
VFD1 Alarms				
V1.1	Warning	VFD1 Over Current warning	VFD is measuring excessive current to the motor. Motor current is approaching the fault limit to run the compressor.	Check wiring between motor and VFD for incorrect or loose connections. Check drive system for proper alignment and wear. Verify supply voltage within tolerance. Decouple compressor from drive motor and check for proper manual rotation. Test motor insulation resistance.

V1.1	Fault	VFD1 Over Current fault	VFD is measuring excessive current to the motor, current has surpassed maximum fault level.	Check wiring between motor and VFD for incorrect or loose connections. Check drive system for proper alignment and wear. Verify supply voltage within tolerance. Decouple compressor from drive motor and check for proper manual rotation. Test motor insulation resistance.
V1.2	Warning	VFD1 Over Voltage warning	VFD has detected that the DC bus voltage has risen above the warning limit, due to motor regen or high input voltage	Verify supply voltage within tolerance. Motor deceleration may be too fast and require parameter adjustment, contact Gardner Denver service.
V1.2	Fault	VFD1 Over Voltage fault	VFD has detected that the DC bus voltage has risen above the fault limit, due to motor regen or high input voltage	Verify supply voltage within tolerance. Motor deceleration may be too fast and require parameter adjustment, contact Gardner Denver service.
V1.3	Warning	VFD1 Earth warning	The VFD has detected a high level of ground current.	Check wiring between motor and VFD for incorrect or loose connections. Ground connections should be checked to make sure there is a solid connection. Inspect motor leads and conduit for damage or wear. Test motor insulation resistance.
V1.3	Fault	VFD1 Earth fault	The VFD has detected a high level of ground current.	Check wiring between motor and VFD for incorrect or loose connections. Ground connections should be checked to make sure there is a solid connection. Inspect motor leads and conduit for damage or wear. Test motor insulation resistance.
V1.5	Fault	VFD1 Charging Circuit fault	The VFD has detected that the charging circuit has faulted.	Verify package supply voltage within tolerance. Check DC bus voltage with meter to verify voltage level (approx. 1.414 times AC Rms input voltage). Reset and restart compressor. If issue persists contact Gardner Denver service.
V1.6	Fault	VFD1 Estop fault	Emergency Stop Pressed. E-Stop digital input signal received.	Reset the E-Stop switch. Refer to machine schematic and check wiring between E-Stop contact and VFD input.
V1.7	Fault	VFD1 Saturation Trip fault	Voltage across drive IGBT exceeds fault limit.	Verify package supply voltage within tolerance. Confirm DC bus voltage within tolerance when idle and running. Contact Gardner Denver service.
V1.9	Warning	VFD1 Under Voltage warning	Low VFD input voltage resulting in Low DC Bus voltage. Below the warning limit, nearing fault level.	Verify package supply voltage within tolerance. Check input wiring connections to VFD. Confirm DC bus voltage within tolerance when idle and running.
V1.9	Fault	VFD1 Under Voltage fault	Low VFD input voltage resulting in Low DC Bus voltage. Below the fault level.	Verify package supply voltage within tolerance. Check input wiring connections to VFD. Confirm DC bus voltage within tolerance when idle and running.
V1.10	Fault	VFD1 Input Phase fault	Input phase imbalance or phase loss in VFD supply	Check L-L voltage between all three phases supplying VFD input. Investigate configuration of 3 phase system supplying compressor package, protection may need to be disabled. Contact Gardner Denver service.
V1.11	Fault	VFD1 Output Phase fault	VFD has detected output phase loss to motor	Check wiring between motor and VFD for damaged or loose connections. Measure output current on the leads to the compressor motor with

				a clamp on amp meter. Test motor insulation resistance.
V1.13	Warning	VFD1 Drive Under Temp warning	Ambient temperature is below the warning limit for the VFD	Raise ambient temperature near the VFD and compressor package.
V1.13	Fault	VFD1 Drive Under Temp fault	Ambient temperature is below the fault limit for the VFD	Raise ambient temperature near the VFD and compressor package.
V1.14	Warning	VFD1 Drive Over Temp warning	VFD is measuring internal temperatures above the warning limit.	Confirm ambient temperature near the VFD is below 50C. Check ventilation filters and fans mounted in the control panel for debris. Check the VFD heat sink cooling fans for correct operation. Clean cooling fans and heat sink fins with compressed air.
V1.14	Fault	VFD1 Drive Over Temp fault	VFD is measuring internal temperatures above the fault limit.	Confirm ambient temperature near the VFD is below 50C. Check ventilation filters and fans mounted in the control panel for debris. Check the VFD heat sink cooling fans for correct operation. Clean cooling fans and heat sink fins with compressed air.
V1.15	Fault	VFD1 Motor Stall fault	Motor has stalled during start or run	Check wiring between motor and VFD for incorrect or loose connections. Check drive system for proper alignment and wear. Verify supply voltage within tolerance. Decouple compressor from drive motor and check for proper manual rotation. Test motor insulation resistance.
V1.15	Warning	VFD1 Motor Stall warning	Motor has stalled during start or run	Check wiring between motor and VFD for incorrect or loose connections. Check drive system for proper alignment and wear. Verify supply voltage within tolerance. Decouple compressor from drive motor and check for proper manual rotation. Test motor insulation resistance.
V1.16	Warning	VFD1 Motor Over Temp warning	VFD has calculated that the motor has been run in an overloaded condition for an extended time and is too	Check wiring between motor and VFD for incorrect or loose connections. Check drive system for proper alignment and wear. Verify supply voltage within tolerance. Decouple compressor from drive motor and check for proper manual rotation. Test motor insulation resistance.
V1.16	Fault	VFD1 Motor Over Temp fault	VFD has calculated that the motor has been run in an overloaded condition for an extended time and is too	Check wiring between motor and VFD for incorrect or loose connections. Check drive system for proper alignment and wear. Verify supply voltage within tolerance. Decouple compressor from drive motor and check for proper manual rotation. Test motor insulation resistance.
V1.19	Fault	VFD1 Power Board EEPROM fault	VFD has detected internal memory error.	Power cycle drive. Contact Gardner Denver service.
V1.20	Fault	VFD1 RAM fault	VFD has detected internal memory error.	Power cycle drive. Contact Gardner Denver service.
V1.21	Warning	VFD1 Serial Flash Warning	VFD has detected internal memory error.	Power cycle drive. Contact Gardner Denver service.
V1.21	Fault	VFD1 Serial Flash Fault	VFD has detected internal memory error.	Power cycle drive. Contact Gardner Denver service.

V1.25	Fault	VFD1 MCU Watchdog fault	VFD has detected internal processing error.	Power cycle drive. Contact Gardner Denver service.
V1.32	Fault	VFD1 Fan Cooling fault	VFD has detected an issue with its heat sink cooling fans	Monitor the heat sink cooling fan operation. Using a multi-meter check for 24VDC/48VDC at the cooling fan pins during run (dependent on VFD size). Replace cooling fans as needed.
V1.36	Fault	VFD1 Device Compatibility fault	VFD has detected and compatibility error between its control board and power board.	Power cycle drive. Contact Gardner Denver service.
V1.37	Warning	VFD1 Device Changed warning	VFD has detected new option card or control board hardware	Power cycle drive. Contact Gardner Denver service.
V1.38	Warning	VFD1 Device Added warning	VFD has detected a new option card has been installed	Power cycle drive. Contact Gardner Denver service.
V1.39	Fault	VFD1 Device Removed fault	VFD has detected removal of an Option card	Power cycle drive. Contact Gardner Denver service.
V1.40	Fault	VFD1 Device Unknown fault	Unknown option card or power board connected to control section.	Power down drive, check option card and ribbon cable are connected. Replace option board or drive.
V1.41	Fault	VFD1 IGBT Temp fault	VFD has detected that IGBT internal temperatures are too high, potentially caused by high motor current	Check motor operating current at full load is not exceeding nominal rating. Check wiring between motor and VFD for incorrect or loose connections. Verify supply voltage within tolerance. Test fan motor insulation resistance.
V1.51	Warning	VFD1 External Input warning	VFD has detected external fault input active	Check for any damage in external cable/wirings and check if there is any loose connections or terminal.
V1.51	Fault	VFD1 External input fault	VFD has detected external fault input active	Check for any damage in external cable/wirings and check if there is any loose connections or terminal.
V1.55	Warning	VFD1 Real Time Clock warning	VFD reporting error with the real time clock	Power cycle drive. Contact Gardner Denver service.
V1.55	Fault	VFD1 Real Time Clock fault	VFD reporting error with the real time clock	Power cycle drive. Contact Gardner Denver service.
V1.58	Fault	VFD1 Current Measure fault	VFD has detected an error with its internal current measuring devices	Power cycle drive. Contact Gardner Denver service.
V1.59	Fault	VFD1 Power Wiring fault	Input/Output wiring to VFD is incorrectly connected	Power the drive down and safely lock out system. Inspect and verify input power wires are properly connected to VFD terminals L1/L2/L3. Inspect and verify motor leads are connected to the VFD output terminals U/V/W.
V1.60	Fault	VFD1 Control Board Over Temp fault	VFD is measuring control board temperatures above the fault limit.	Confirm ambient temperature near the VFD is below 50C. Check ventilation filters and fans mounted in the control panel for debris. If equipped, confirm the small control board cooling fan is operational.
V1.61	Fault	VFD1 Internal control power supply fault	VFD is reporting that the internal 24VDC control supply outside the range of 18-27VDC	Using a multi-meter, measure 24VDC supply at the control board terminals. If the voltage is in range, power cycle the drive. If out of range, contact Gardner Denver service.

V1.63	Fault	VFD1 Current Imbalance fault	The VFD has detected an output phase imbalance of more than 20%	Check VFD output terminal connections to the motor. Check the condition of the motor leads, and the connections in the motor junction box. Measure current with a clamp on amp meter in each lead between the VFD & motor. Test fan motor insulation resistance.
V1.64	Warning	VFD1 Replace Battery warning	The VFD's real time clock battery is near depletion	Replace the RTC battery
V1.64	Fault	VFD1 Replace Battery fault	The VFD's real time clock battery is depleted	Replace the RTC battery
V1.65	Warning	VFD1 Replace Fan warning	VFD has calculated that its cooling fan life is less than 2 months.	Inspect condition and operation of heat sink cooling fans. Replace as needed.
V1.65	Fault	VFD1 Replace Fan fault	VFD has calculated that its cooling fan life is less than 2 months.	Inspect condition and operation of heat sink cooling fans. Replace as needed.
V1.66	Warning	VFD1 Safe Torque Off warning	Emergency Stop Pressed. E-Stop digital input signal received.	Reset the E-Stop switch. Refer to machine schematic and check wiring between E-Stop contact and cooling VFD input.
V1.66	Fault	VFD1 Safe Torque Off fault	Emergency Stop Pressed. E-Stop digital input signal received.	Reset the E-Stop switch. Refer to machine schematic and check wiring between E-Stop contact and cooling VFD input.
V1.67	Warning	VFD1 Current Limit control warning	VFD is actively limiting output current to the compressor motor, motor is overloaded	Check wiring between motor and VFD for incorrect or loose connections. Verify supply voltage within tolerance. Check drive system for proper alignment and wear. Decouple compressor from drive motor and check for proper manual rotation. Test motor insulation resistance.
V1.68	Warning	VFD1 over Voltage limit warning	VFD has detected that the DC bus voltage has risen above the warning limit, due to motor regen or high input voltage	Verify supply voltage within tolerance. Motor deceleration may be too fast and require parameter adjustment, contact Gardner Denver service.
V1.69	Fault	VFD1 System fault	Internal communication error within the VFD	Try performing a power cycle to see if fault clears. Contact Gardner Denver service
V1.83	Fault	VFD1 Communications fault	VFD has detected an error in the Modbus RTU communication between it and the compressor controller	Check the communication cabling between the controller and the VFD. Confirm proper cable routing (avoiding parallel runs with AC power lines), and confirm cable shielding drains are terminated to ground terminals.
V1.96	Warning	VFD1 Parameter error Warning	Internal parameter error within the VFD	Try performing a power cycle to see if fault clears. Contact Gardner Denver service.
V1.96	Fault	VFD1 Parameter fault	Internal parameter error within the VFD	Try performing a power cycle to see if fault clears. Contact Gardner Denver service.
V1.104	Warning	VFD1 Firmware compatibility warning	Internal firmware compatibility error within the VFD	Try performing a power cycle to see if fault clears. Contact Gardner Denver service.
V1.104	Fault	VFD1 Firmware comp ability fault	Internal firmware compatibility error within the VFD	Try performing a power cycle to see if fault clears. Contact Gardner Denver service.
V1.105	Warning	VFD1 warning	Controller has detected an unknown warning code in the VFD	Check the VFD's keypad for specific warning code and reference the VFD user manual for appropriate action. Contact Gardner Denver service

V1.106	Fault	VFD1 fault	Controller has detected an unknown fault code in the VFD	Check the VFD's keypad for specific fault code and reference the VFD user manual for appropriate action. Contact Gardner Denver service
V1.107	Fault	VFD1 communications lost fault	Controller has detected an error in the Modbus RTU communication between it and the VFD	Check the communication cabling between the controller and the VFD. Confirm proper cable routing (avoiding parallel runs with AC power lines), and confirm cable shielding drains are terminated to ground terminals.
V1.201	Fault	VFD Initialization Fail fault	Controller has detected a parameter initialization problem with the VFD	Confirm proper machine configuration selection through the model setup page on the controller. Check the communication cabling between the controller and the VFD. Confirm proper cable routing (avoiding parallel runs with AC power lines), and confirm cable shielding drains are terminated to ground terminals.
Water Pump Alarms				
WP.0	Fault	Water Pump Auxiliary Input fault	The contactor coil failed or the wiring to the coil or auxiliary contact is disconnected. The contactor could be stuck in the open or closed position.	Check wiring to the contactor coil and auxiliary contact for the Water Pump. Use the digital output IO diagnostics function in the controller to check operation of the contactor. If the contactor is not operating properly use an ohm-meter to check the resistance on the coil of the contactor. Attempt to operate the contactor manually to ensure it is not stuck in place.

5.1.1 Contact Info:

Select the **Contact Info** Button on the bottom left side of the page, the **Contact Info** page will be opened. A quick link has been provided to reach out for the best support and service in case the user needs help in handling any particular alarm. As shown in Figure 172, the **Contact Info Name** is set to *Gardner Denver*. The values displayed here are set on the *Service>Distributor Info* page.



Figure 172: Contact Info

5.1.2 Info:

The **Info** Button available next to the **Contact Info** button, gives more information about a specific alarm. Select the Alarm from the list then select the **Info** Button and an **Alarm Info** screen will come up with details such as *Operating Stats, Total Hours, Loaded Hours, Reservoir Pressure, Delivery Pressure, and Discharge Temp*. See Figure 173 below with an example of the **Alarm Info** screen. Note, the information available on the alarm info page will vary based on the machine features.

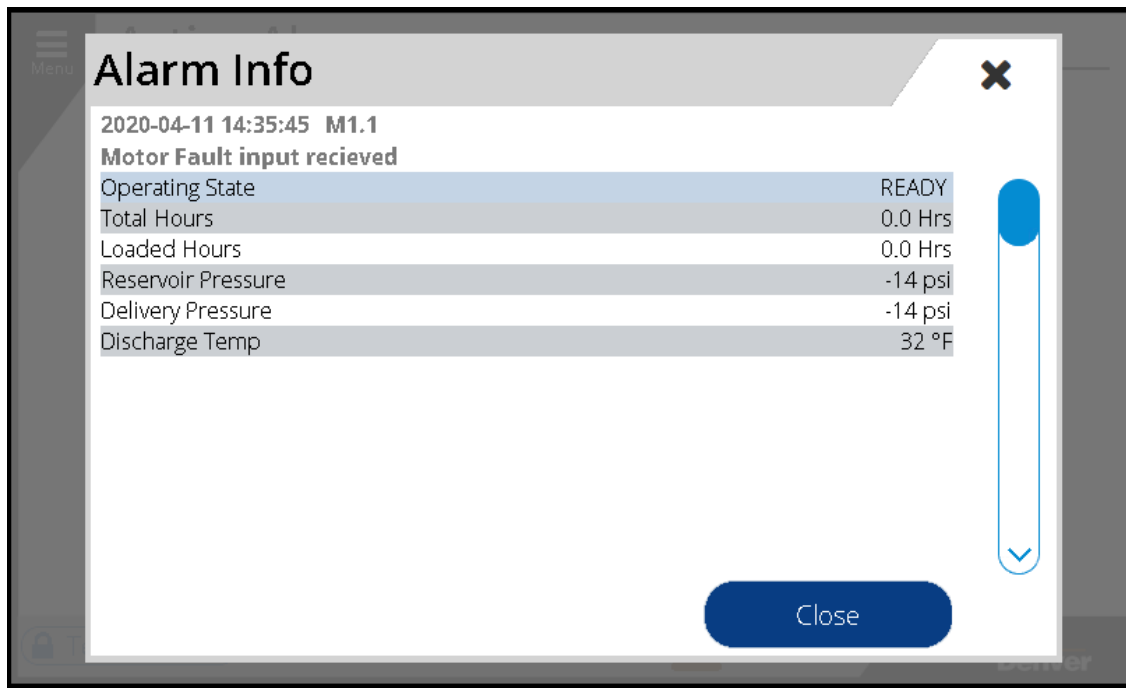

Figure 173: Alarm Info

The **Active Alarm** page has a link to the **Alarm History** Page. Press the **Alarm History** Button. Once corrective actions have been taken, hit the **Reset All** button to clear the **Active Alarm** list.

5.2 Alarm History

The **Alarm History** page lists all the alarms the system has experienced in the order they occurred. As shown in Figure 174 below, the alarm column has various symbols that represent different alarm types. Table 46 shows the possible symbols in the alarm column and a description for each.

Table 46: Alarm Symbols

Alarm Symbols	
Alarm	Description
	A yellow outlined triangle shows a warning alarm that is no longer active and can be reset.
	A yellow solid triangle shows a warning alarm that is still active, but the machine can continue to operate.
	A red outlined triangle shows a fault alarm that is no longer active and may be reset.
	A red solid triangle shows a fault alarm that is still active and must be resolved before it can be cleared.
	The green check shows the time, date, code, and message of alarms that have been resolved in the system.
	The flag shows when a snap shot of the current machine data has been taken from the schematic page.

Alarm History

Alarm	Timestamp	Code	Message
⚠	2020-04-11 14:35:46	C.15	Check IO Modules: Failed to receive Module OK status from all module
⚠	2020-04-11 14:35:45	M1.1	Motor Fault input recieved
⚠	2020-04-11 14:35:45	P.1	Emergency Stop Pressed
⚠	2020-04-11 14:35:45	F1.1	Cooler Fan Fault input recieved
⚠	2020-04-11 14:35:45	P.2	Low DC Supply Voltage to Controller
⚠	2020-04-11 14:35:45	M1.2	Motor Temperature PTC Fault
✅	2020-04-08 09:53:13	P.2	Low DC Supply Voltage to Controller
✅	2020-04-08 09:53:13	F1.1	Cooler Fan Fault input recieved
✅	2020-04-08 09:53:13	P.1	Emergency Stop Pressed
✅	2020-04-08 09:53:13	M1.1	Motor Fault input recieved

Info Active Alarms

Technician 13 Apr 2020 11:47 AM Gardner Denver

Figure 174: Alarm History

The **Info** Button available on the **Alarm History Page** is the same as described in section 5.1.2. The **Info** button will be available for alarm and snapshot events but disabled for acknowledged events as shown in Figure 175 below. The **Active Alarms** button takes the user back to the **Active Alarms** page.

Alarm History

Alarm	Timestamp	Code	Message
⚠	2020-04-11 14:35:46	C.15	Check IO Modules: Failed to receive Module OK status from all module
⚠	2020-04-11 14:35:45	M1.1	Motor Fault input recieved
⚠	2020-04-11 14:35:45	P.1	Emergency Stop Pressed
⚠	2020-04-11 14:35:45	F1.1	Cooler Fan Fault input recieved
⚠	2020-04-11 14:35:45	P.2	Low DC Supply Voltage to Controller
⚠	2020-04-11 14:35:45	M1.2	Motor Temperature PTC Fault
✅	2020-04-08 09:53:13	P.2	Low DC Supply Voltage to Controller
✅	2020-04-08 09:53:13	F1.1	Cooler Fan Fault input recieved
✅	2020-04-08 09:53:13	P.1	Emergency Stop Pressed
✅	2020-04-08 09:53:13	M1.1	Motor Fault input recieved

Info Active Alarms

Technician 13 Apr 2020 11:47 AM Gardner Denver

Figure 175: Alarm History

SECTION 6

DIAGNOSTICS

This section explains the diagnostics and troubleshooting options and settings available to the user. The user can review and monitor the status of the machine in a number of different ways. Table 47 below gives a brief summary about the sub-menus for diagnostics and brief information about each.

Table 47: Diagnostics

Diagnostics	
Sub-Menu	Brief Information
6.1 Sequencing	The User can see the sequencing System Overview, including the status of online units, Sequence #, loaded hours, etc.
6.2 Jog Motors	The User can perform the motor jog by setting the parameters such as Jog Duration, Selected Motor, and, Jog Delay.
6.3 IO	The User can view the status of Digital, Temperature, and Analog inputs and outputs. Digital outputs may also be controlled through this page.
6.4 Controller	The User can see the General and Advanced information about the controller, Logs, and System status. Software updates may be performed through this page.
6.5 iConn	The User can see iConn info and status.
6.6 Communication	The Communication channel's status can be seen here.
6.7 Remote Control	The current state of all remote control functions can be viewed from this page.
6.8 VFD Diagnostics	The user can see the information about the variable frequency drive used on this machine, if applicable.

6.1 Sequencing

The **Sequencing** Diagnostics page gives an overview of the sequencing settings for the machine. The *compressor name, run hours, capacity, and operating pressure* is also shown at the top of this page as well as other information depending on the mode selected.

As more compressors are added to the sequenced network, the white space fills with additional compressor information. Four compressors are shown in the example below. Each unit is represented by a rectangle which has the information shown in Figure 162 below for the *ES+* sequencing protocol.

The screens will appear different depending on the sequencing protocol being used. The *AirSmart* sequencing diagnostics page is shown in Figure 177 below. The *Delcos* sequencing diagnostics page is different depending on if the machine is configured for a master or slave. Figure 178 and Figure 179 shows the *Delcos* sequencing diagnostics pages.

Refer to Governor sequencing manual (13-17-625) for more detailed information on the sequencing diagnostics.

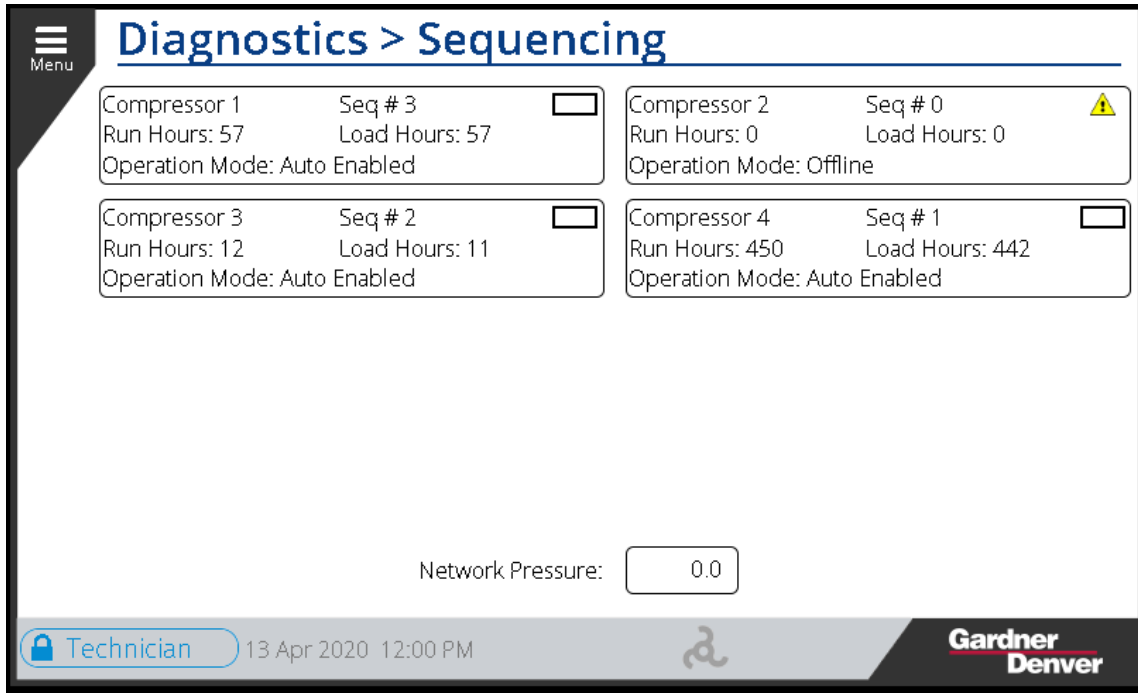

Figure 176: Sequencing Diagnostics – ES+ Protocol

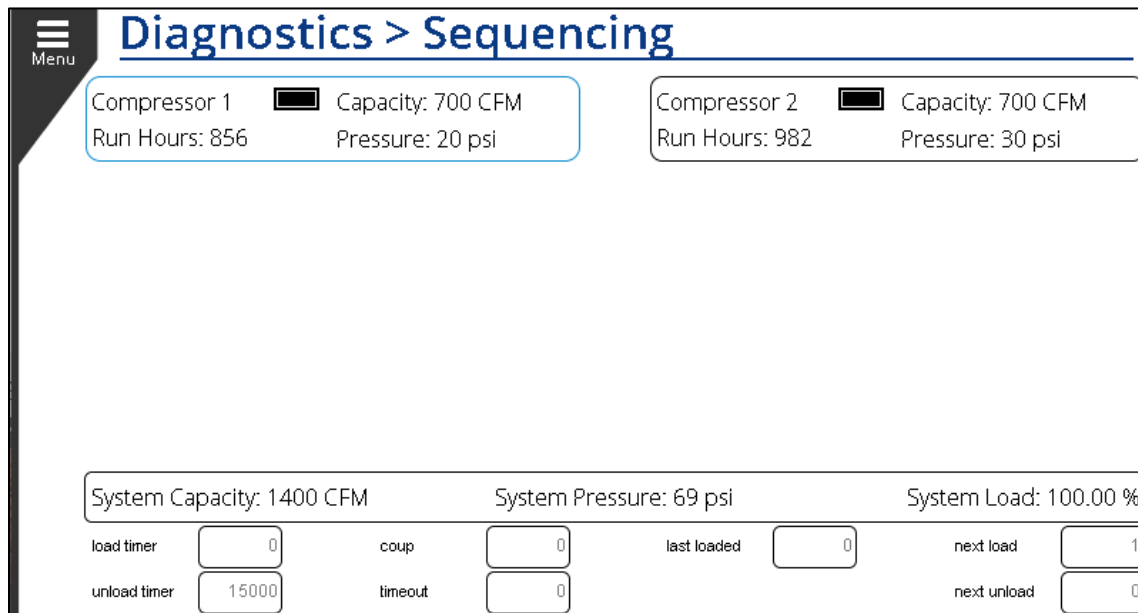

Figure 177: Sequencing Diagnostics - AirSmart Protocol

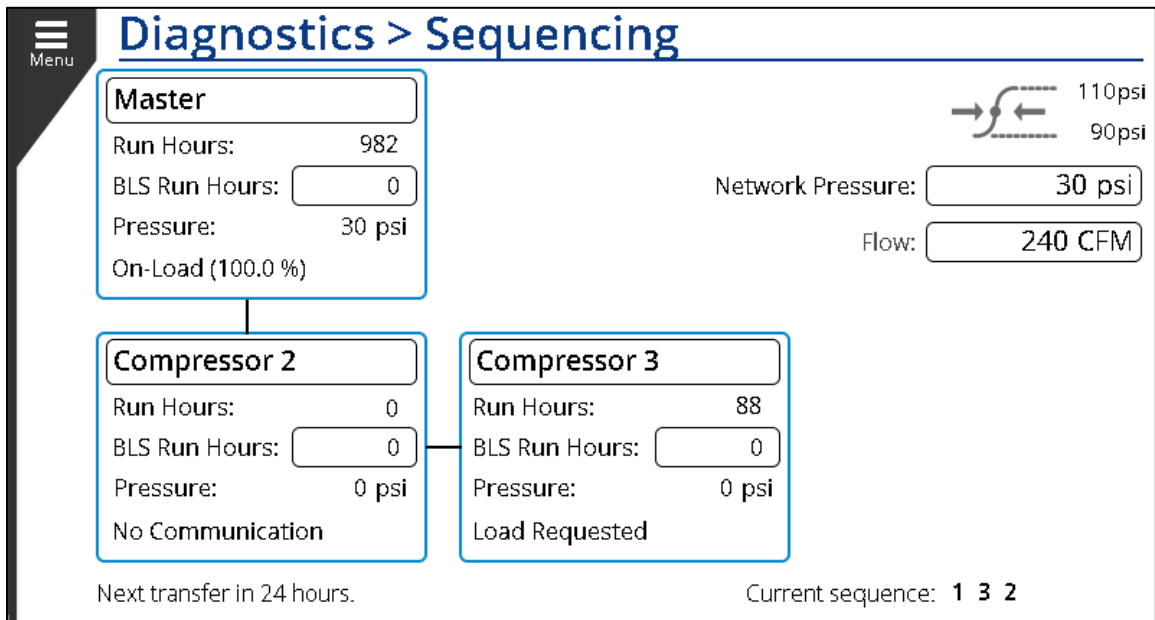

Figure 178: Sequencing Diagnostics - Delcos Protocol - Master

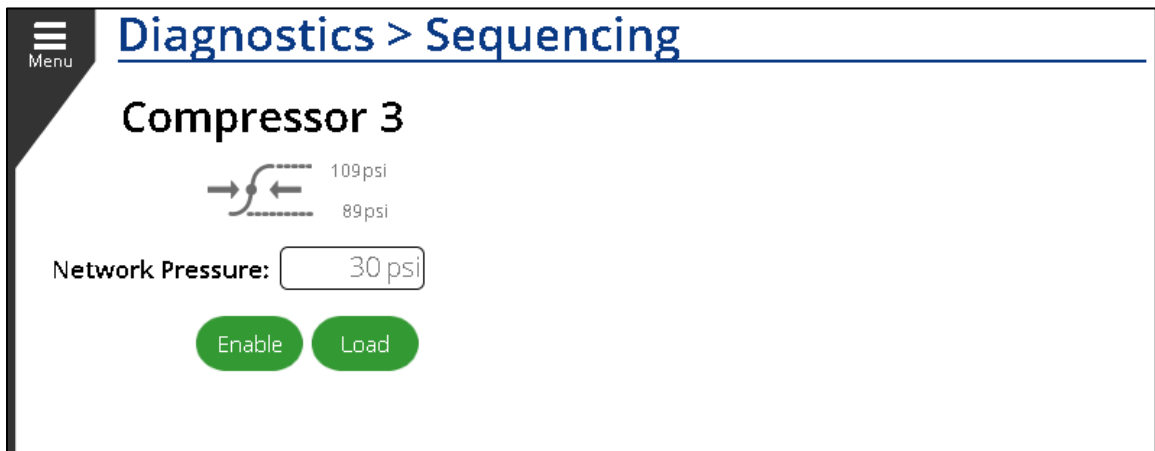

Figure 179: Sequencing Diagnostics - Delcos Protocol - Slave

6.2 Jog Motors

The **Jog Motor** diagnostics screen is used to run the motors in the system for a short amount of time to make sure they are rotating in the right direction. Running the motor in the wrong direction can cause damage to the machine. This function should be utilized anytime there is a risk that the AC power phases changed sequence, such as on initial startup.

This page lists the following three parameters: *Jog Duration*, *Selected Motor*, and *Jog Delay*.

6.2.1 Jog Duration:

The Motor **Jog Duration** is the amount of time the motor will be run during the jog operation. The shortest amount of time sufficient to turn the motor should be used. This value can be set between *0.2 Second*, *0.5 Second*, and *1 second*. Figure 180 below shows the selection of **Jog Duration** set as *0.2 second*.

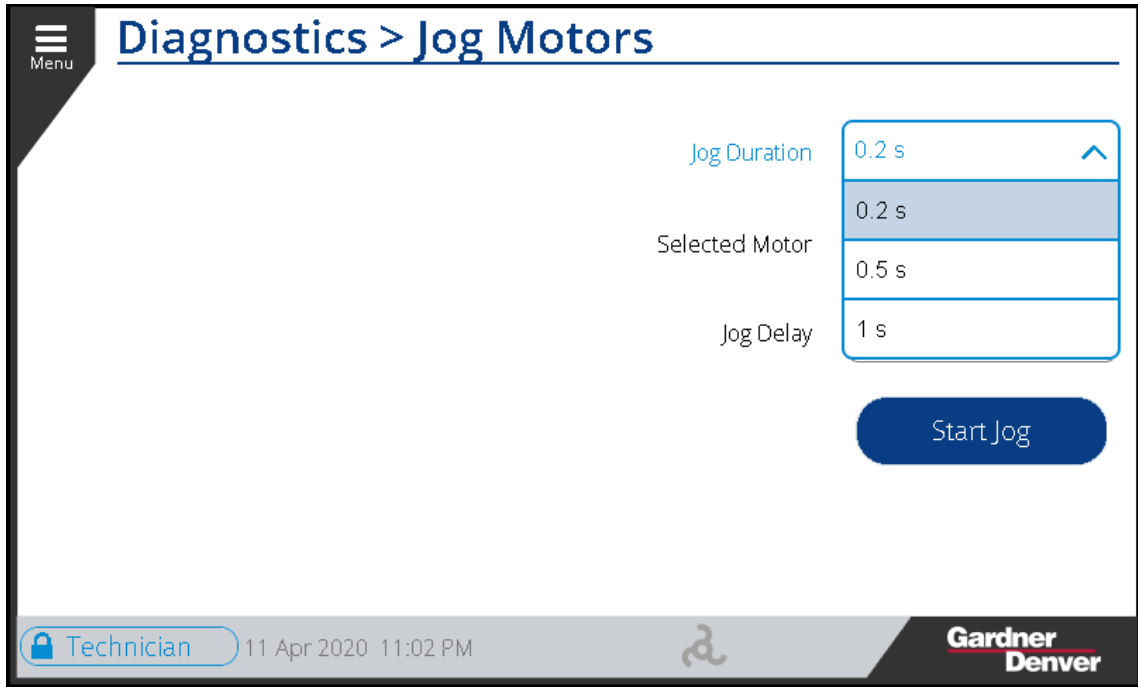

Figure 180: Jog Duration

6.2.2 Selected Motor:

In the system there are two types of motors: *Compressor* and *Fan*. Select the motor you wish to jog from the dropdown menu. Figure 181 below shows the selection of *compressor motor*.



Figure 181: Selected Jog Motor

6.2.3 Jog Delay:

The **Jog Delay** setting allows the user to insert a delay between pressing the start job button and the start of the motor jog operation. Figure 182 shows setting the **Jog Delay** with the keypad. This allows the user time to get into a position where the motor can be viewed to observe rotation.

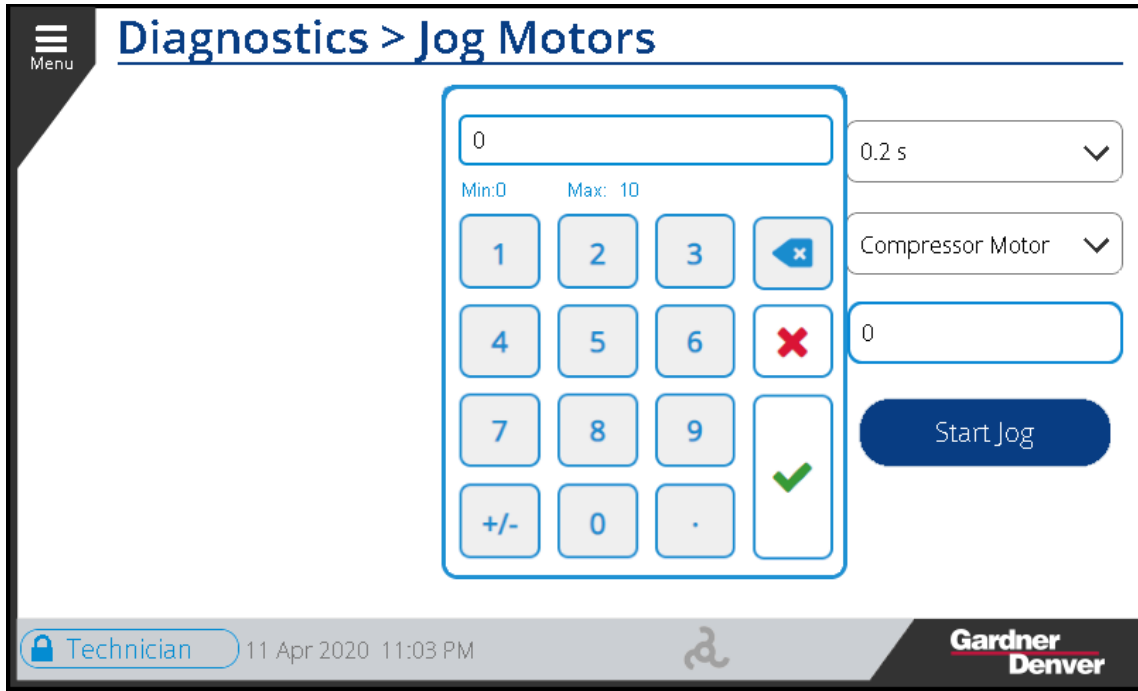

Figure 182: Jog Delay

Once set the user can hit the **Start Jog** button to start the test jog. Note, once the jog function has been activated, another jog may not be started until 10 seconds have passed since the previous jog.

6.3 IO

The **IO Diagnostics** screen gives the status of **IO** signals for the **Digital Inputs**, **Digital Outputs**, **Temperature Inputs**, **Analog Inputs**, and **Analog Outputs**.

Digital Inputs:

Figure 183 below shows the tab for the **Digital Inputs**. Each Input number represents the channel number of the input. To see which parameter is assigned against each channel number you can refer to the **Settings > Programmable I/O** screen, as well as the machine wiring diagram.

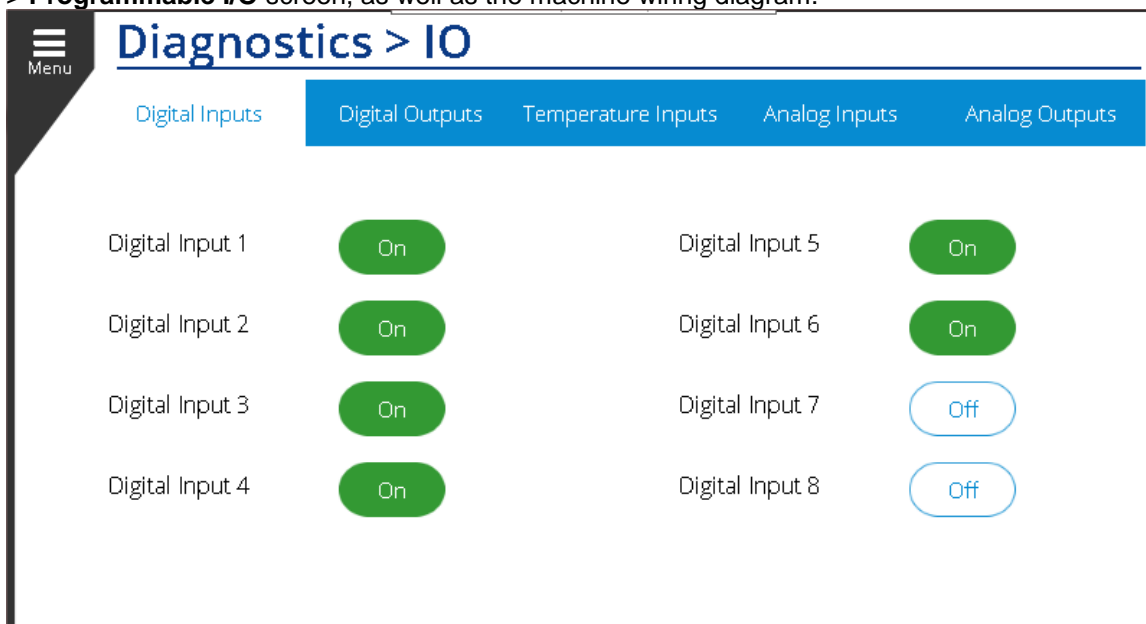

Figure 183: Digital Inputs

Digital Outputs:

Figure 184 below shows the screen for **Digital Output** signals. The feedback is a readout of the status of the output pin while the value column represents the commanded state. The Value and Feedback for each output should match if the output is working properly. If these do not match, the output may be shorted or overloaded or there may be not power signal applied to the appropriate digital output bank.

If the machine is not running, the outputs may be forced to a specific value by pressing the **Enable Output Forcing** button in the bottom right of the screen. Note that any device connected to the output pin such as a motor or valve will be toggled based on the values that are set in this mode. When output forcing is enabled, pressing on the value column for a specific output will turn that output on or off.

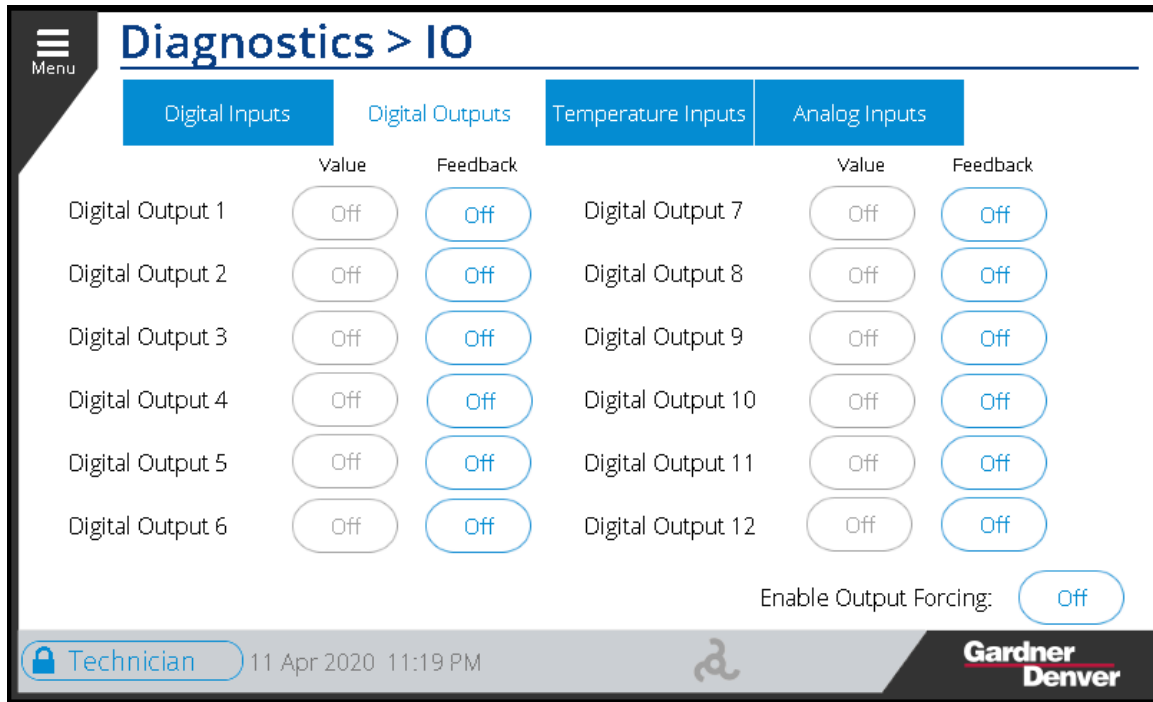

Figure 184: Digital Output

Temperature Inputs:

The **Temperature Inputs** tab shows the raw and scaled values for each of the temperature probes connected on the machine. As shown in Figure 185 below, the raw value for temperature is typically 1/10th of the actual value in °C while the scaled value is equivalent to °F. The PTC input is used to measure the status of a thermal device in a motor. Raw resistance can be measured on these inputs. The example below has the **PTC Status** toggled *ON*.

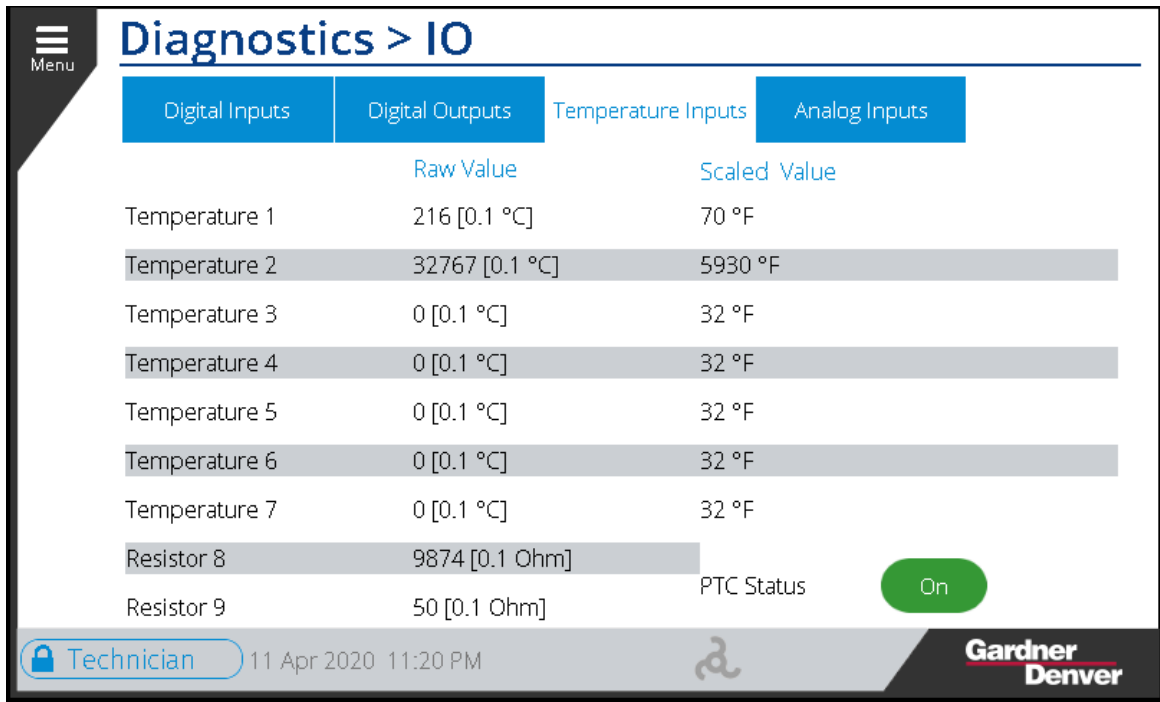

Figure 185: Temperature Inputs

Analog Inputs:

Similar to the Temperature Inputs tab, the **Analog Inputs** tab lists the raw and scaled values for each of the analog sensors on the machine. Figure 186 below shows the **Analog Input** screen.

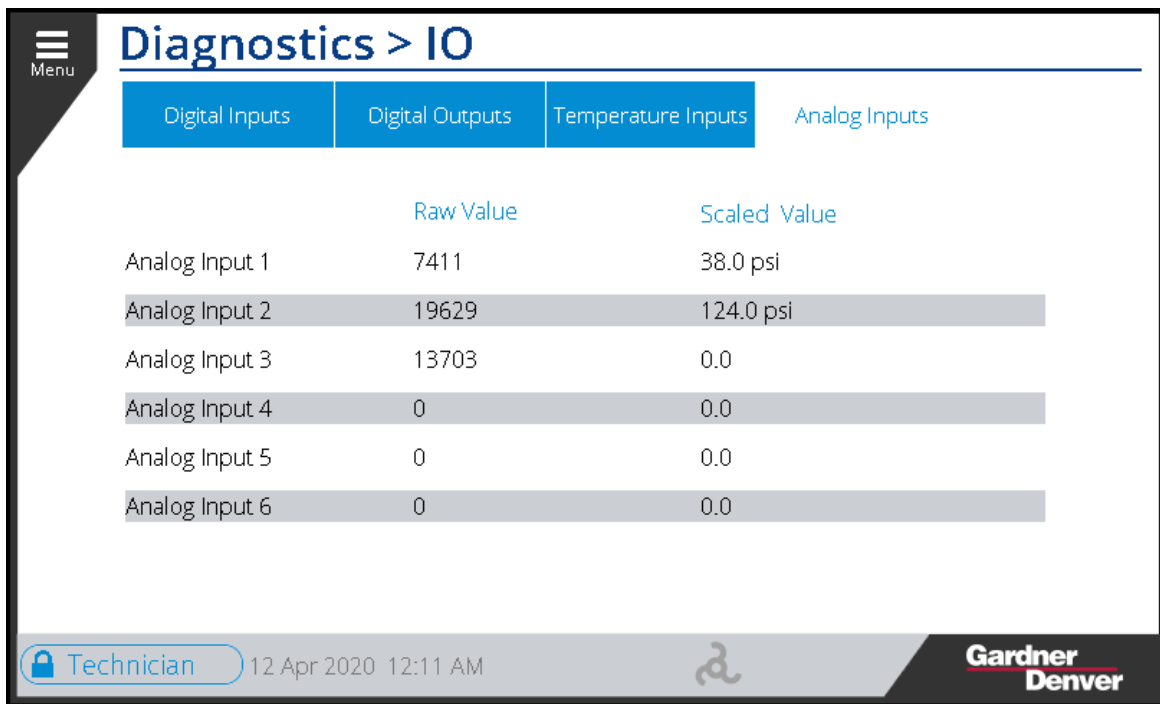

Figure 186: Analog Inputs

Analog Outputs:

Similar to the Analog Inputs tab, the **Analog Outputs** tab lists the raw and scaled values for each of the analog sensors on the machine. Figure 187 below shows the **Analog Outputs** screen.

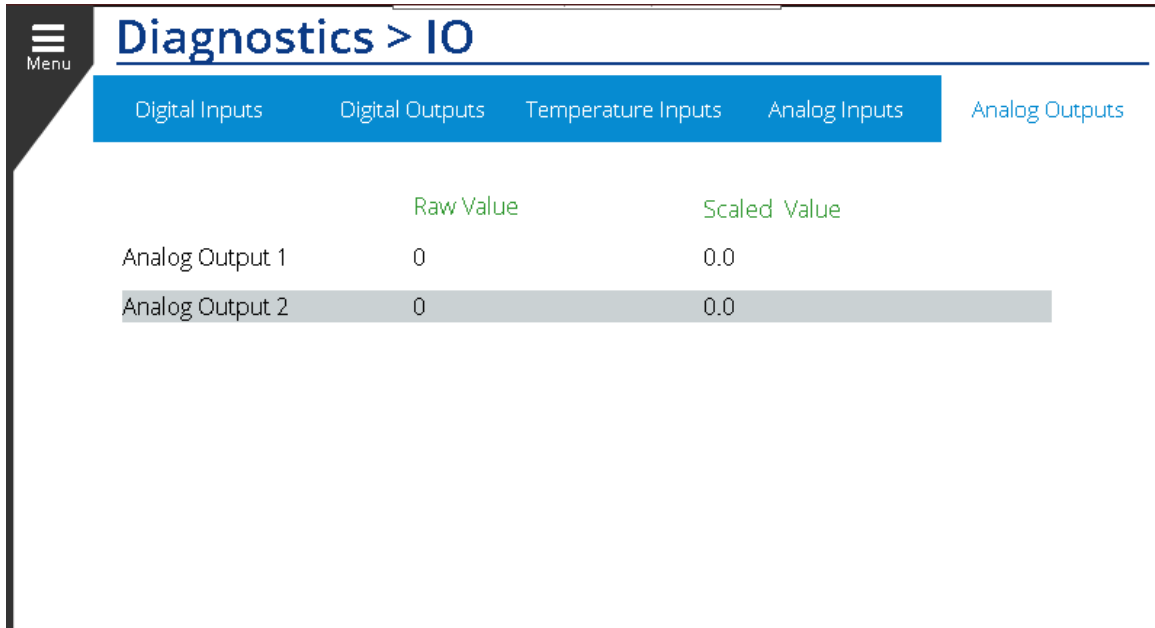

Figure 187: Analog Outputs

6.4 Controller

The **Controller** section of the **Diagnostics** menu gives information about controller, its operation, and running status. This is also a place where the software can be updated. A list of the sub-menus under the **Controller** menu and a description of each can be found in Table 48 below.

Table 48: Controller Menus

Controller	
Sub-Menu	Brief Information
6.4.1 General:	The user can see general information about the controller and access the update software interface.
6.4.2 Logs:	The user can download the controller logs onto a flash drive.
6.4.3 System:	The user can view information about the status of the controller and its operation.
6.4.4 Update Software	The user can see the current software version being used and update the controller software to the latest version.
6.4.5 Audit:	The user can view a record of all the changes made to the system.
6.4.6 Logger:	The user can view the system logs and select a specific logger.
6.4.7 Advanced:	Lists files on the controller and the size of each folder in the structure.

6.4.1 General:

Figure 188 below shows the Controller's **General** Info. This includes: *Total motor starts*, *IO module Serial Number*, *Controller Serial Number*, *Controller Software Version*, *Controller Software ID*, *AR Version*, *DC Supply*, *Build ID*, and *Build Timestamp*.

Along with above information, there is an **Update Software** button. Refer to Section 6.4.4 Update Software for more information on updating the controller software.

The *DC Supply* is the current value of the control voltage and can be useful in troubleshooting. The other values may be referenced by Gardner Denver Support to determine if a software update should be performed on the controller.

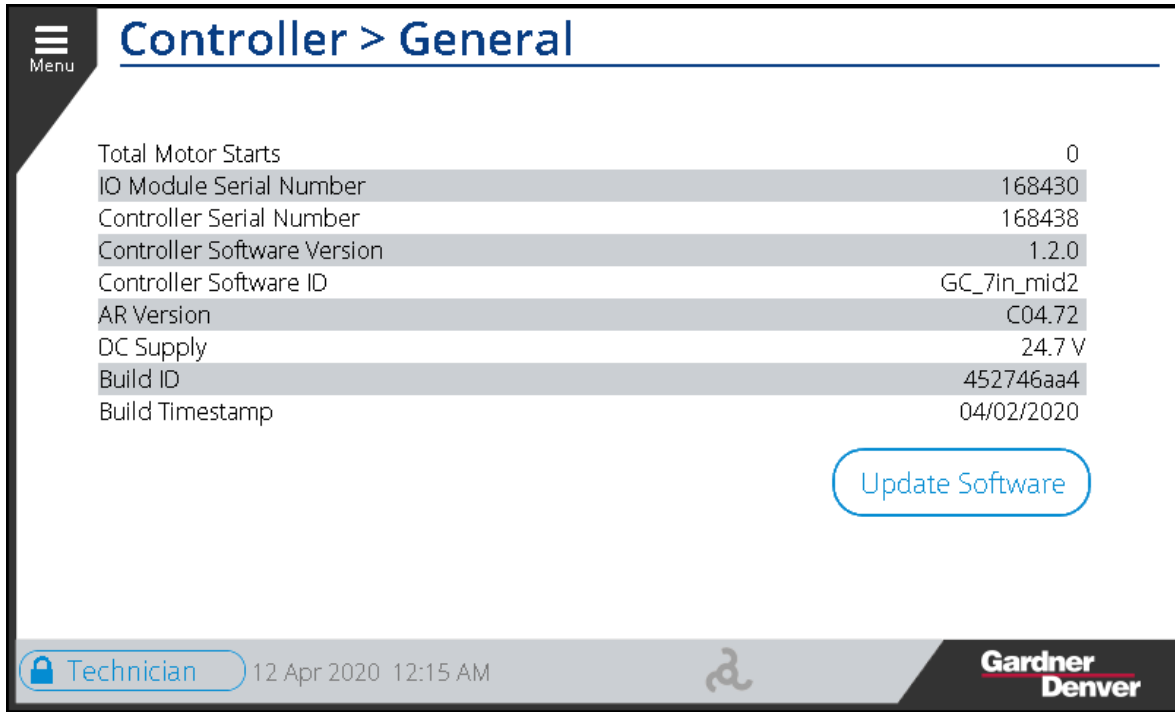

Figure 188: Controller General Information

6.4.2 Logs:

The controller has a data recording function which enables the user to save log files to a flash drive. This function can be used to monitor and save various compressor parameters for evaluation of system performance and troubleshooting.

To save the **Log** to a flash drive, first insert the USB drive into an open port on the controller and then press the **Save** button and the logs will be downloaded. If there is no flash drive available then the system the **Save** button will be disabled and grayed out. Figure 189 below shows what the page s like when a flash drive is connected, hit the **Save** button to start the transfer of data.

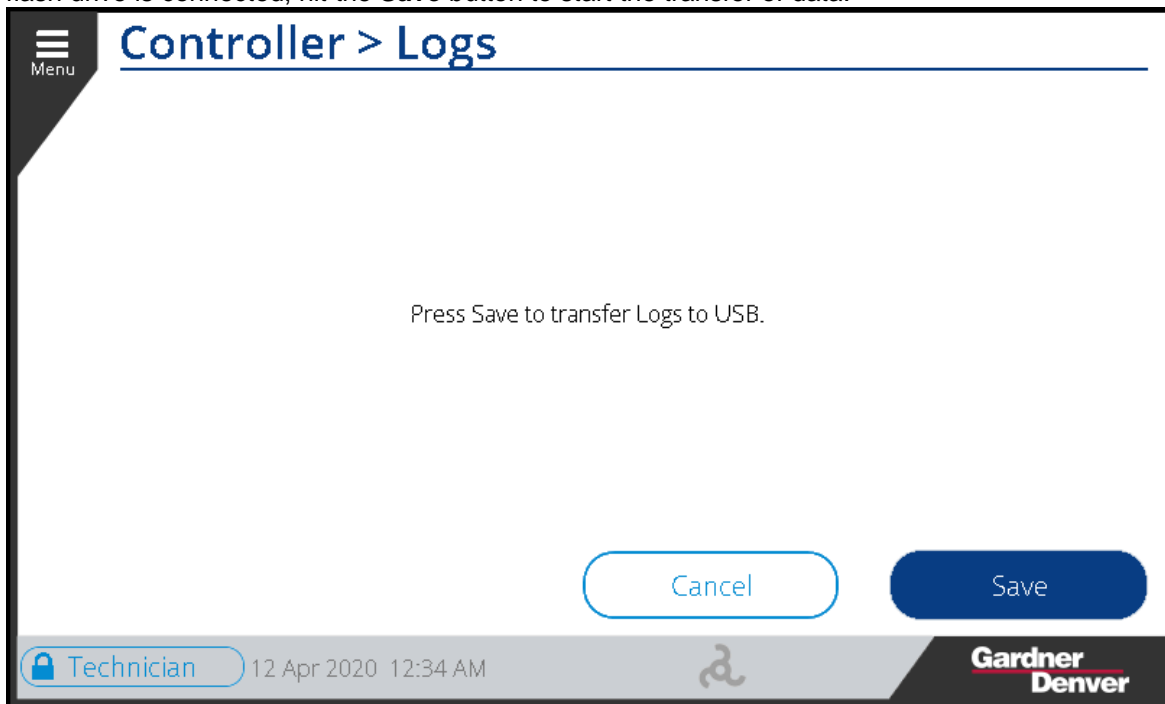

Figure 189: Controller Logs

Once the files have been transferred to the flash drive it may be removed and inserted to a PC for review. The files downloaded from the controller will be stored in a “gz archive” file and will need to first be unzipped and extracted to a folder for viewing by right-clicking on the file and extracting. Figure 190 shows the downloaded files and extracted folder. Two extractions are required, first for the gz archive and second for the tar archive.

Name	Date modified	Type	Size
_GCExport_168421_20200825_163109.tar.gz	8/25/2020 16:31	gz Archive	2,295 KB
_GCExport_168421_20200825_163109.tar	8/25/2020 16:31	tar Archive	3,560 KB
_GCExport_168421_20200825_163109	8/25/2020 11:32	File folder	

Figure 190: Downloaded Files

Figure 191 below shows the files contained in the unzipped folder. The folders and files contained here are explained in more detail below.

Name	Date modified	Type	Size
Audit	5/10/2020 5:20 PM	File folder	
DataRecorder	5/10/2020 5:20 PM	File folder	
EventTrace	5/10/2020 5:20 PM	File folder	
BuR_SDM_Sysdump_2020-05-01_10-55_11.tar.gz	5/10/2020 5:20 PM	GZ File	2,066 KB
Frame4LRS_55kw_460v.csv	5/10/2020 5:20 PM	Microsoft Excel Com...	26 KB
LRS_Def.csv	5/10/2020 5:20 PM	Microsoft Excel Com...	39 KB
MachParameters.csv	5/10/2020 5:20 PM	Microsoft Excel Com...	16 KB
Package.pkg	5/10/2020 5:20 PM	PKG File	1 KB

Figure 191: Log Folder

Audit:

The Audit folder contains files which hold a record of the activities performed on the controller. The Audit report are text files that may be opened with any text editor. Figure 192 shows a typical view of Audit file opened on the computer. For example, the top entry in the file below shows that on May 1st, 2020 at 10:40:21 the Heavy Start-Up Fault Alarm was acknowledged. Another example is the event that occurred on May 1st, 2020 at 09:41:26 which shows that the Technician user changed the value of ‘star/delta time’ from 5 seconds to 7 seconds.

```

Audit-Trail Export File
Information:
Export=1588344910.864 -04: by Technician
TextSource=AR/TextSystem | (V1.00)
Language=
Data:
2020-05-01 10:40:21 Alarm: HeavyStartupFault Old state: Unacknowledged, New state:Acknowledged
2020-05-01 10:39:57 Alarm: HeavyStartupFault Old state: Inactive, New state:Active
2020-05-01 10:39:57 Alarm: HeavyStartupFault Old state: Inactive, New state:Active
2020-05-01 09:54:07 Alarm: DI_ESTOP_OK Old state: Unacknowledged, New state:Acknowledged
2020-05-01 09:54:07 Alarm: VFD1Fault Old state: Unacknowledged, New state:Acknowledged
2020-05-01 09:53:57 Alarm: VFD1Fault Old state: Inactive, New state:Active
2020-05-01 09:53:57 Alarm: DI_ESTOP_OK Old state: Inactive, New state:Active
2020-05-01 09:44:44 Alarm: HeavyStartupFault Old state: Unacknowledged, New state:Acknowledged
2020-05-01 09:44:23 Alarm: HeavyStartupFault Old state: Inactive, New state:Active
2020-05-01 09:44:23 Alarm: HeavyStartupFault Old state: Inactive, New state:Active
2020-05-01 08:42:09 Alarm: HeavyStartupFault Old state: Unacknowledged, New state:Acknowledged
2020-05-01 09:41:52 Alarm: HeavyStartupFault Old state: Inactive, New state:Active
2020-05-01 09:41:26 Technician: Value of 'star/delta time ' changed. Old: 5.00 , New: 7.00
2020-05-01 09:18:10 Alarm: HeavyStartupFault Old state: Unacknowledged, New state:Acknowledged
2020-05-01 08:27:47 Alarm: HeavyStartupFault Old state: Inactive, New state:Active
2020-05-01 08:27:47 Alarm: HeavyStartupFault Old state: Inactive, New state:Active
2020-05-01 08:27:18 Alarm: HeavyStartupFault Old state: Unacknowledged, New state:Acknowledged
2020-05-01 08:24:45 Alarm: HeavyStartupFault Old state: Inactive, New state:Active
2020-05-01 08:24:45 Alarm: HeavyStartupFault Old state: Inactive, New state:Active
2020-05-01 08:23:08 Alarm: HeavyStartupFault Old state: Unacknowledged, New state:Acknowledged
2020-05-01 08:21:38 Alarm: HeavyStartupFault Old state: Inactive, New state:Active
2020-05-01 08:21:38 Alarm: HeavyStartupFault Old state: Inactive, New state:Active
2020-05-01 08:21:19 Alarm: HeavyStartupFault Old state: Unacknowledged, New state:Acknowledged
2020-05-01 08:20:24 Alarm: HeavyStartupFault Old state: Inactive, New state:Active
2020-05-01 08:20:24 Alarm: HeavyStartupFault Old state: Inactive, New state:Active
2020-05-01 08:16:30 Alarm: DI_ESTOP_OK Old state: Unacknowledged, New state:Acknowledged
2020-05-01 08:16:30 Alarm: PowerLossFault Old state: Unacknowledged, New state:Acknowledged
2020-05-01 08:16:30 Alarm: VFD1Fault Old state: Unacknowledged, New state:Acknowledged
2020-04-30 15:45:00 Alarm: VFD1Fault Old state: Inactive, New state:Active
2020-04-30 15:44:59 Alarm: DI_ESTOP_OK Old state: Inactive, New state:Active
2020-04-30 15:17:55 Alarm: HeavyStartupFault Old state: Inactive, New state:Active
2020-04-30 15:17:55 Alarm: HeavyStartupFault Old state: Inactive, New state:Active

```

Figure 192: Audit Report

Data Recorder:

The Data Recorder folder contains logs recording various values of the system during operation. Figure 193 below shows the contents of the Data Recorder folder.











Name	Date modified	Type	Size
 Datalog_2014_12_31_18_01_02.csv	5/10/2020 5:20 PM	Microsoft Excel Com...	1 KB
 Datalog_2015_01_01_00_08_28.csv	5/10/2020 5:20 PM	Microsoft Excel Com...	1 KB
 Datalog_2020_03_26_10_43_34.csv	5/10/2020 5:20 PM	Microsoft Excel Com...	1 KB
 Datalog_2020_03_26_10_43_37.csv	5/10/2020 5:20 PM	Microsoft Excel Com...	2 KB
 Datalog_2020_03_26_10_47_23.csv	5/10/2020 5:20 PM	Microsoft Excel Com...	30 KB
 Datalog_2020_04_30_09_47_56.csv	5/10/2020 5:20 PM	Microsoft Excel Com...	2 KB
 Datalog_2020_04_30_10_14_22.csv	5/10/2020 5:20 PM	Microsoft Excel Com...	11 KB
 Datalog_2020_04_30_11_16_05.csv	5/10/2020 5:20 PM	Microsoft Excel Com...	57 KB
 Datalog_2020_05_01_08_16_30.csv	5/10/2020 5:20 PM	Microsoft Excel Com...	19 KB
 Package.pkg	5/10/2020 5:20 PM	PKG File	1 KB

Figure 193: Data Recorder Folder

The file named “Datalog_2020_05_01_08_16_30.csv” contains the logs of the system after the previously generated log. In this example it would include the logs between 30th-April 11:16:05 to 1st-May 08:16:30. Figure 194 below shows an example of the Data Recorder Log file. Note that the parameters that are logged will change based on the configuration and features of the machine. The entries in the data recorder files will be logged at different intervals depending on the current state of the machine. Typically, entries will be

made once every 10 minutes if the machine is not running, every 20 seconds during normal operation, and every 1 second during the starting phase.

Timestamp	Total Hours [UDINT]	Loaded Hours [UDINT]	State [UDINT]	Current Fault [STRING]	Current Warning [STRING]	Load Pressure [REAL]	Target Pressure [REAL]	Unload Pressure [REAL]	AI_RESERVOIR_PRESSURE [REAL]	AI_PLANT_DELIVERY_PRESSURE [REAL]	AI_DISCHARGE_TEMPERATURE [REAL]	DO_MAINTENANCE_STATUS [REAL]	DO_AUTO_OPERATION [REAL]
2020 05 01 08:16:30:422	9308	7042	0	V1.106	0	7.1	7.1	7.38	0	-0.01	11.8	TRUE	FALSE
2020 05 01 08:16:31:232	9308	7042	1	V1.106	0	7.1	7.1	7.38	0	-0.01	11.8	FALSE	FALSE
2020 05 01 08:20:01:771	9308	7042	5	V1.106	0	7.1	7.1	7.38	0	7.07	11.8	FALSE	TRUE
2020 05 01 08:20:18:871	9308	7042	3	V1.106	0	7.1	7.1	7.38	0	7.07	12	FALSE	FALSE
2020 05 01 08:20:20:071	9308	7042	3	V1.106	0	7.1	7.1	7.38	0	7.07	12	FALSE	FALSE
2020 05 01 08:20:21:271	9308	7042	3	V1.106	0	7.1	7.1	7.38	0.02	7.07	12	FALSE	FALSE
2020 05 01 08:20:22:471	9308	7042	3	V1.106	0	7.1	7.1	7.38	0.85	7.06	12.4	FALSE	FALSE
2020 05 01 08:20:23:671	9308	7042	3	V1.106	0	7.1	7.1	7.38	2.57	7.06	17.1	FALSE	FALSE
2020 05 01 08:20:24:771	9308	7043	0	P.6	0	7.1	7.1	7.38	4.96	7.07	26.3	TRUE	FALSE
2020 05 01 08:20:45:071	9308	7043	0	P.6	0	7.1	7.1	7.38	1.62	7.07	15.7	TRUE	FALSE
2020 05 01 08:21:05:271	9308	7043	0	P.6	0	7.1	7.1	7.38	0.54	7.06	14.6	TRUE	FALSE
2020 05 01 08:21:19:471	9308	7043	1	P.6	0	7.1	7.1	7.38	0.17	7.06	14	FALSE	FALSE
2020 05 01 08:21:25:071	9308	7043	5	P.6	0	7.1	7.1	7.38	0.1	7.06	13.8	FALSE	TRUE
2020 05 01 08:21:33:471	9308	7043	3	P.6	0	7.1	7.1	7.38	0.09	7.06	13.8	FALSE	FALSE
2020 05 01 08:21:34:671	9308	7043	3	P.6	0	7.1	7.1	7.38	0.09	7.06	13.9	FALSE	FALSE
2020 05 01 08:21:35:871	9308	7043	3	P.6	0	7.1	7.1	7.38	0.36	7.06	13.8	FALSE	FALSE
2020 05 01 08:21:37:071	9308	7043	3	P.6	0	7.1	7.1	7.38	1.32	7.06	14.1	FALSE	FALSE
2020 05 01 08:21:38:271	9308	7044	3	P.6	0	7.1	7.1	7.38	3.18	7.06	20.4	FALSE	FALSE
2020 05 01 08:21:39:071	9308	7044	0	P.6	0	7.1	7.1	7.38	4.91	7.06	29.6	TRUE	FALSE

Figure 194: Datalog File

Event Trace:

The Event Trace folder contains logs created when a specific event occurred. These files include the same information that is available in the Data Recorder files but at a higher resolution for a short period of time preceding a fault. Entries in this file will be made every 500ms. Each file will include several minutes worth of data. Figure 195 below shows the Event Trace Folder containing various log files created with the name of Exported Snapshot.



















 ExportedSnapshot_2014_12_31_18_00_52.csv	5/10/2020 5:20 PM	Microsoft Excel Com...	1 KB
 ExportedSnapshot_2015_01_01_00_08_20.csv	5/10/2020 5:20 PM	Microsoft Excel Com...	1 KB
 ExportedSnapshot_2015_01_01_00_09_48.csv	5/10/2020 5:20 PM	Microsoft Excel Com...	12 KB
 ExportedSnapshot_2020_03_26_10_43_39.csv	5/10/2020 5:20 PM	Microsoft Excel Com...	30 KB
 ExportedSnapshot_2020_03_26_10_44_54.csv	5/10/2020 5:20 PM	Microsoft Excel Com...	31 KB
 ExportedSnapshot_2020_03_26_10_47_13.csv	5/10/2020 5:20 PM	Microsoft Excel Com...	1 KB
 ExportedSnapshot_2020_03_26_13_22_43.csv	5/10/2020 5:20 PM	Microsoft Excel Com...	32 KB
 ExportedSnapshot_2020_04_30_09_50_15.csv	5/10/2020 5:20 PM	Microsoft Excel Com...	33 KB
 ExportedSnapshot_2020_04_30_09_52_49.csv	5/10/2020 5:20 PM	Microsoft Excel Com...	33 KB
 ExportedSnapshot_2020_04_30_09_53_28.csv	5/10/2020 5:20 PM	Microsoft Excel Com...	32 KB
 ExportedSnapshot_2020_04_30_09_55_10.csv	5/10/2020 5:20 PM	Microsoft Excel Com...	32 KB
 ExportedSnapshot_2020_04_30_10_01_17.csv	5/10/2020 5:20 PM	Microsoft Excel Com...	32 KB
 ExportedSnapshot_2020_04_30_10_02_55.csv	5/10/2020 5:20 PM	Microsoft Excel Com...	32 KB
 ExportedSnapshot_2020_04_30_10_14_18.csv	5/10/2020 5:20 PM	Microsoft Excel Com...	2 KB
 ExportedSnapshot_2020_04_30_10_18_38.csv	5/10/2020 5:20 PM	Microsoft Excel Com...	35 KB
 ExportedSnapshot_2020_04_30_10_21_10.csv	5/10/2020 5:20 PM	Microsoft Excel Com...	36 KB
 ExportedSnapshot_2020_04_30_10_28_50.csv	5/10/2020 5:20 PM	Microsoft Excel Com...	36 KB
 ExportedSnapshot_2020_04_30_10_46_38.csv	5/10/2020 5:20 PM	Microsoft Excel Com...	35 KB
 ExportedSnapshot_2020_04_30_10_59_35.csv	5/10/2020 5:20 PM	Microsoft Excel Com...	35 KB

Figure 195: Event Trace Folder

Each file created lists the various parameters at various times, as shown in Figure 196 below.

Timestamp	Total Hours [UDINT]	Loaded Hours [UDINT]	State [UDINT]	Current Fault [STRING]	Current Warning [STRING]	Load Pressure [REAL]	Target Pressure [REAL]	Unload Pressure [REAL]	AI_ RESERVOIR_ PRESSURE [REAL]	AI_ PLANT_ DELIVERY_ PRESSURE [REAL]	AI_ DISCHARGE_ TEMPERATURE [REAL]
2014 12 31 18:00:50:162	7580	6837	0	V1.106	0	9.51	9.72	10.07	0	0	13.9
2014 12 31 18:00:50:757	7580	6837	0	V1.106	0	9.51	9.72	10.07	0	-0.01	13.9
2014 12 31 18:00:51:257	7580	6837	0	V1.106	0	9.51	9.72	10.07	0	-0.01	13.9
2014 12 31 18:00:51:757	7580	6837	0	V1.106	0	9.51	9.72	10.07	0	-0.01	13.8
2014 12 31 18:00:52:257	7580	6837	0	V1.106	0	9.51	9.72	10.07	0	-0.01	13.9
2014 12 31 18:00:52:757	7580	6837	0	V1.106	0	9.51	9.72	10.07	0	-0.01	13.9

Figure 196: Event Trace data log file

Machine Configuration Files:

In addition to the above folders, the logger folder contains 3 configuration files shown in Figure 197 below. These files contain all of the current settings and configurations of the machine.



 Frame4LRS_55kw_460v.csv	5/10/2020 5:20 PM	Microsoft Excel Com...	26 KB
 LRS_Def.csv	5/10/2020 5:20 PM	Microsoft Excel Com...	39 KB
 MachParameters.csv	5/10/2020 5:20 PM	Microsoft Excel Com...	16 KB

Figure 197: Machine Configuration Files

System Dump File:

The logs also contain the system dump files which can be used by Gardner Denver support for diagnostics. If this file is requested, please forward to Gardner Denver support. Figure 198 shows the system dump file for this example.

 BuR_SDM_Sysdump_2020-05-01_10-55_11.tar.gz	5/10/2020 5:20 PM	GZ File	2,066 KB
--	-------------------	---------	----------

Figure 198: System Dump File

6.4.3 System:

The Controller **System** screen gives information about the status of the controller and its operation. The System menu has been distributed between 6 tabs. Note under most circumstances the user will not need to access this page and it will only be needed when directed by Gardner-Denver service or engineering.

SDM:

The SDM screen shows the status of each element of the system. Figure 199 below shows the SDM tab.

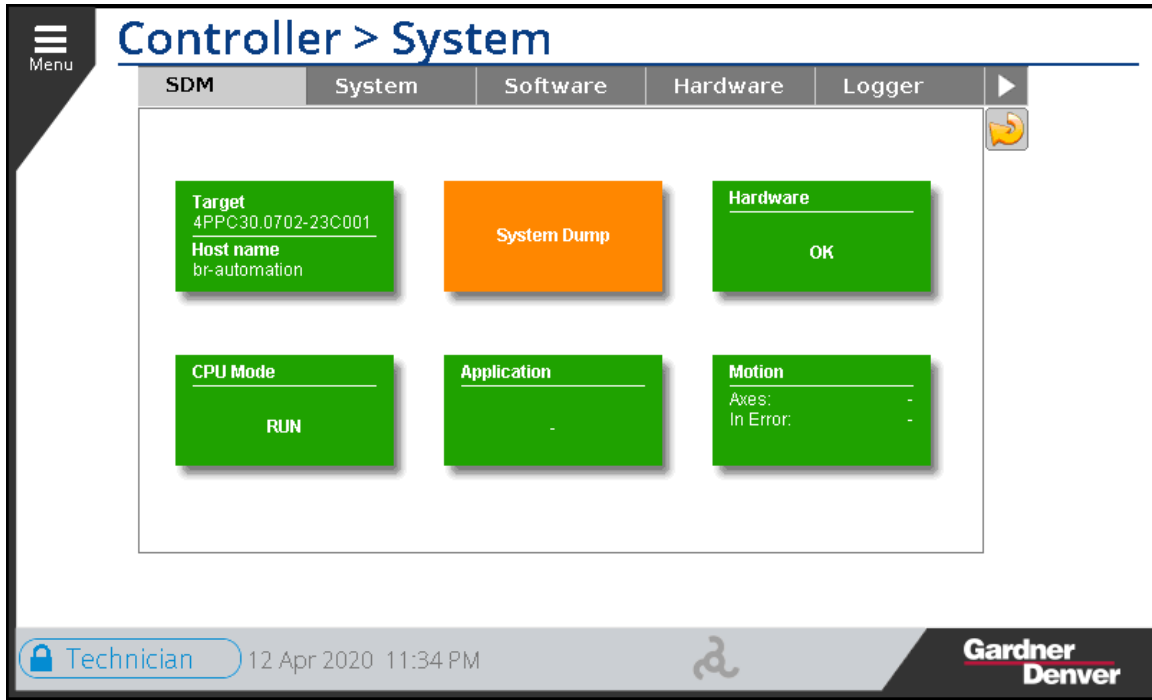

Figure 199: System SDM

System:

The System Tab lists the operational values, time synchronization, software versions, and CPU configuration information. Figure 200 below shows the System screen.

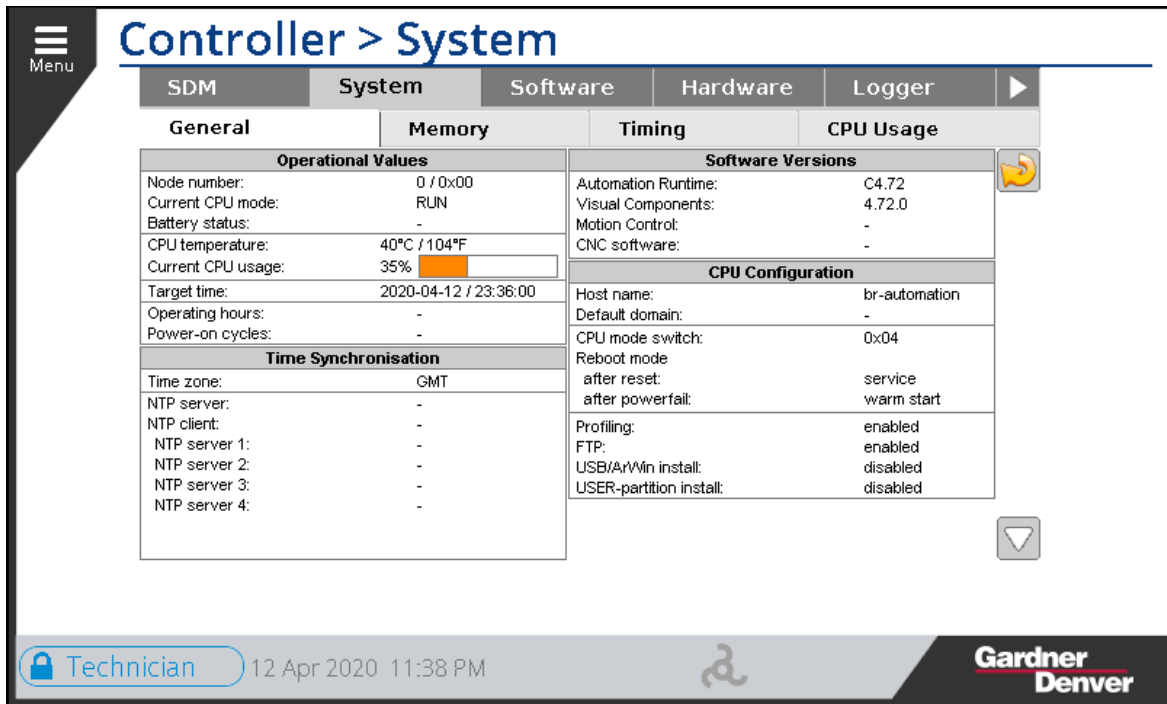

Figure 200: System

Software:

The Software information page will list the software configuration. Figure 201 shows the Software tab.

SDM	System	Software	Hardware	Logger		
Module	Version	Date / Time	Type	Memory	Address	Size
07291553f	4.00.2	2020-07-29 / 15:53:01	Data objects	UserROM	0x00000000	2MiB
07271313f	4.00.2	2020-07-27 / 13:13:56	Data objects	UserROM	0x00000000	2MiB
_Init	1.02.0	2015-02-05 / 05:07:58	Other objects	UserROM	0x833d4c80	119KiB
_VisCtrl	1.02.0	2015-02-05 / 05:07:58	Other objects	UserROM	0x833f27e0	15KiB
_FileHandl	1.02.0	2015-02-05 / 05:07:59	Other objects	UserROM	0x833f65e0	15KiB
_FX30USBLi	1.02.0	2015-02-05 / 05:07:59	Other objects	UserROM	0x833fa3e0	15KiB
_MachCfg	1.02.0	2015-02-05 / 05:07:59	Other objects	UserROM	0x833fe300	15KiB
_SeqCtrl	1.02.0	2015-02-05 / 05:07:59	Other objects	UserROM	0x83402100	15KiB
_JOCtrl	1.02.0	2015-02-05 / 05:07:59	Other objects	UserROM	0x83405f00	15KiB
_Process	1.02.0	2015-02-05 / 05:07:59	Other objects	UserROM	0x83409e20	15KiB
_Utilities	1.02.0	2015-02-05 / 05:07:59	Other objects	UserROM	0x8340dc20	15KiB
_AlarmMoni	1.02.0	2015-02-05 / 05:08:00	Other objects	UserROM	0x83411b40	15KiB
_VrdCtrl	1.02.0	2015-02-05 / 05:08:00	Other objects	UserROM	0x83415940	15KiB
_DataModel	1.02.0	2015-02-05 / 05:08:00	Other objects	UserROM	0x83419740	15KiB
_SerialCom	1.02.0	2015-02-05 / 05:08:00	Other objects	UserROM	0x8341d660	1MiB
_HealthChe	1.02.0	2015-02-05 / 05:08:01	Other objects	UserROM	0x8358eae0	15KiB

page 1 of 15

Figure 201: Software

Hardware:

The Hardware screen shows the status of hardware within the hardware tree. It also have the Module Status and Module details. Figure 202 below shows the hardware status with green tick marks.

Hardware Tree

- ✓ 4PPC30.0702-23C001
- ✓ IF3(ETHERNET)
- ✓ IF4(CAN)
- ✓ XEPCMB105.03C
 - ✓ IF1(X2X)
 - ✓ XEPCMB105.03Cio
- ✓ IF5(RS485)

Module path: -

Module Status

ModuleOk: -

Configured: 4PPC30.0702-2...

Plugged: 4PPC30.0702-2...

Module Details

B&R serial number: F6340168430

Firmware version: -

Hardware revision: -

Hardware variant: 1

Equipment ID: 4PPC30_0702_...

Technician 12 Apr 2020 11:53 PM

Figure 202: Hardware

Logger:

The Logger page lists logs for various machine modules. The User can either view it right on the screen or save it, see Figure 203 below.

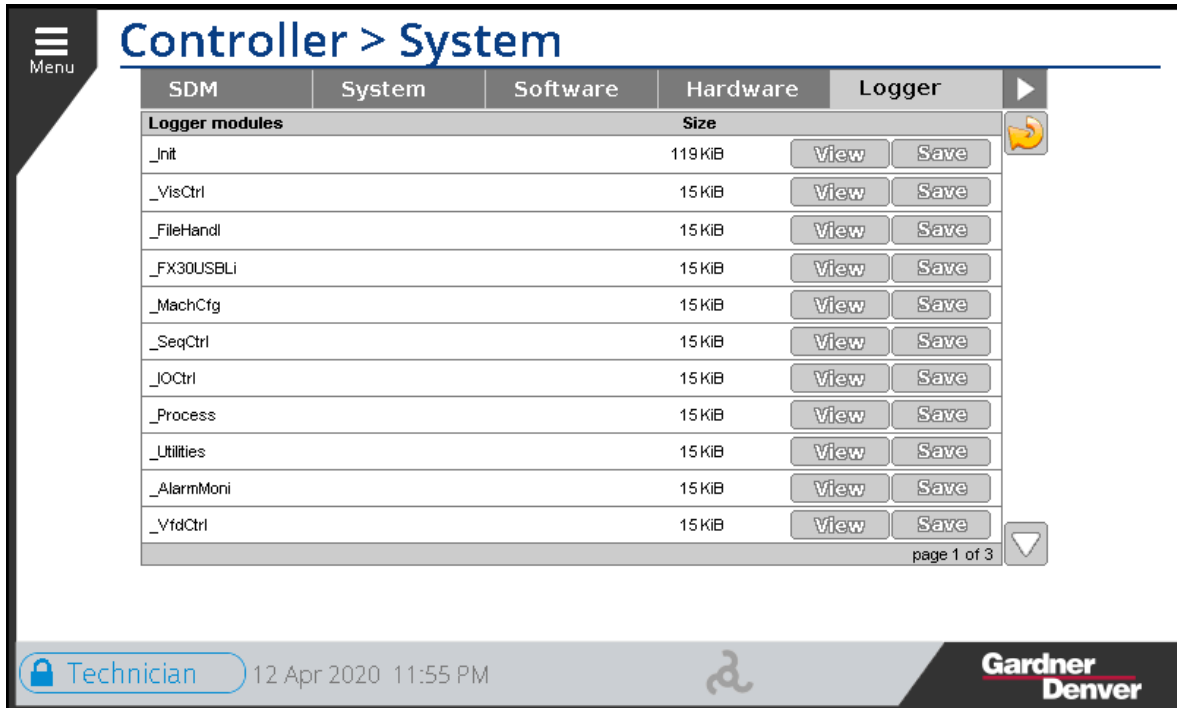

Figure 203: Logger

To view the details right on the screen, hit the View button. Another screen with more details will show up as shown in Figure 204 below.

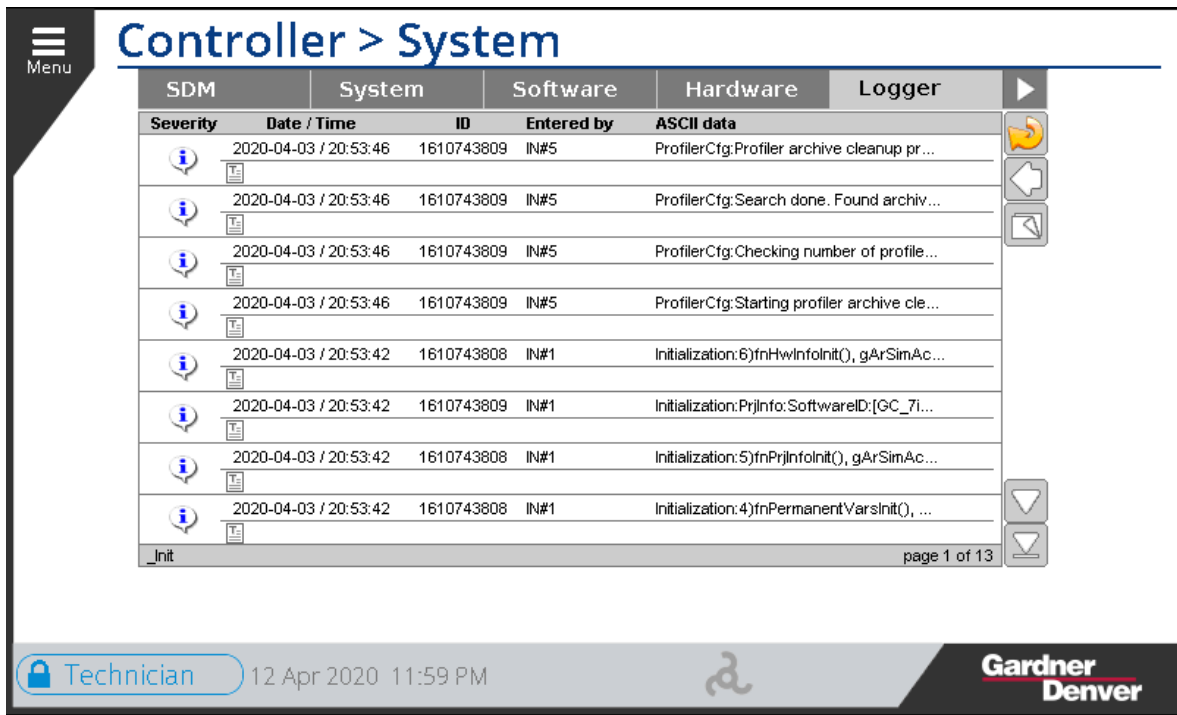





Figure 204: Logger Details

Hit  to return to previous screen of Logger.

Hit  to refresh the page.

Hit  to select how many pages show at a time. It will be as shown in Figure 205 below.

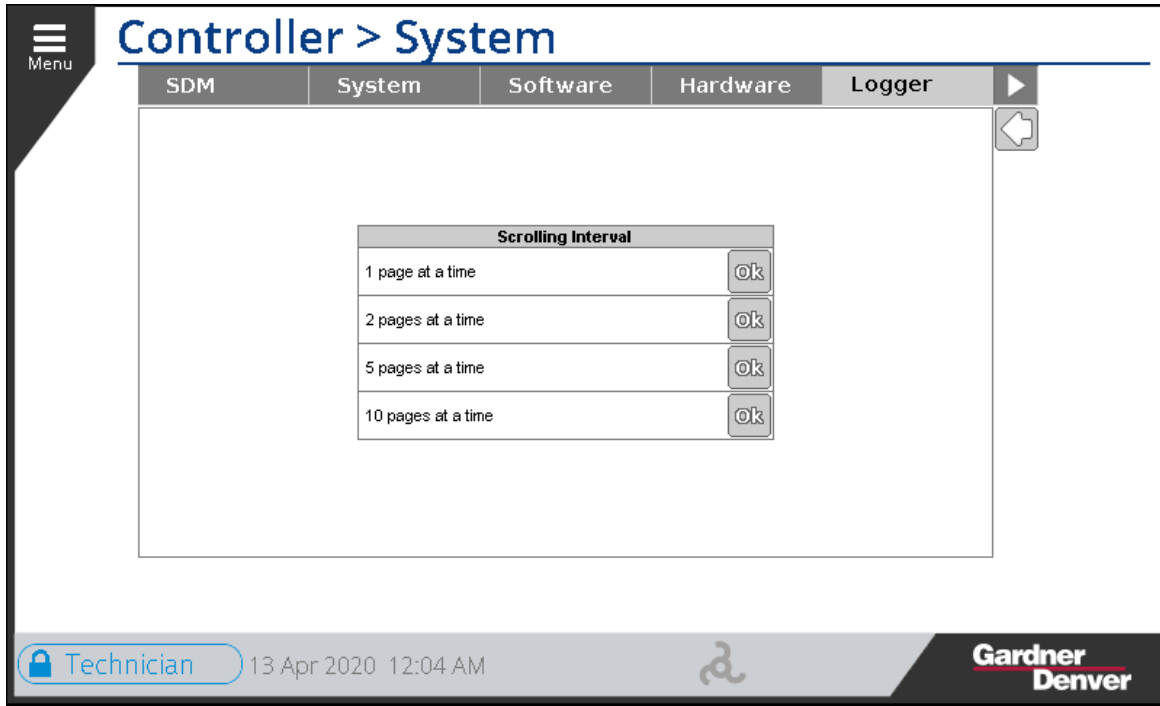

Figure 205: Logger Details

Profiler:

The Profiler in Figure 206 is a high level Diagnostic tool which keeps track of all the changes taking place with very fine level of details. By default there will be default profiler running and keeping record of all the changes. Note, the user should not modify this page unless directed to by Gardner Denver.

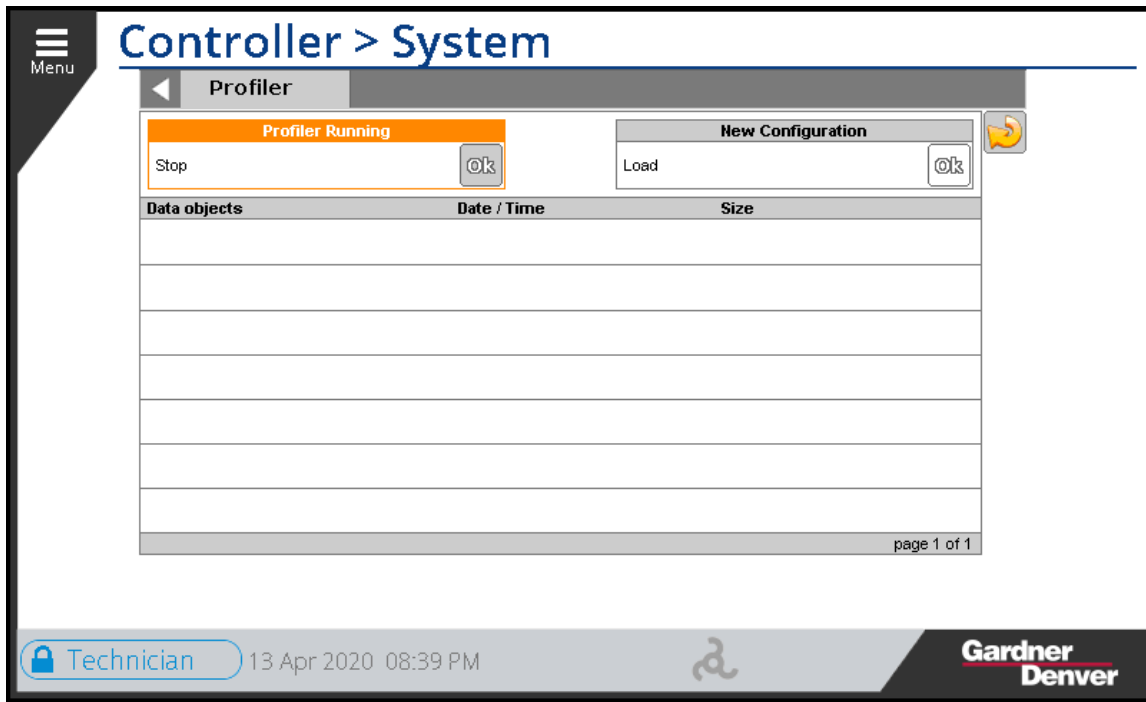

Figure 206: Profiler

6.4.4 Update Software

The **Update Software** screen will show the list of available software versions to install. In order to install new software insert a USB device with the desired software on it and then select the software from the list. Once the software has been selected, press the install button to update the controller. This screen also show the current software version and Configuration ID at bottom left of the screen. Figure 207 below shows the **Update Software** Screen.

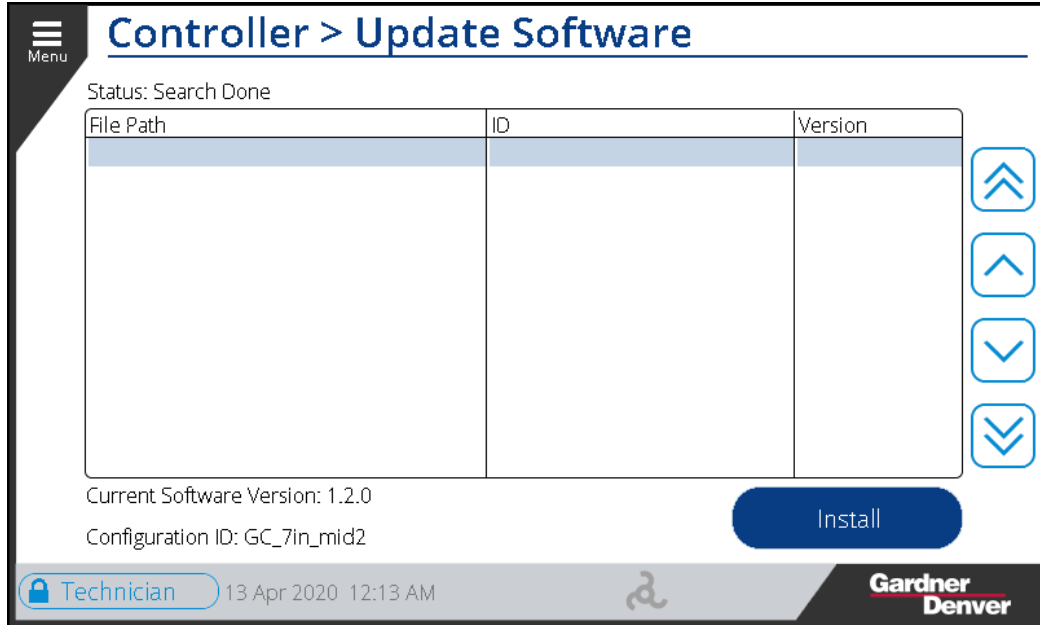

Figure 207: Update Software

6.4.5 Audit:

The **Audit** log is a record of all the changes made to the system. This includes details such as changes to settings, as well as resetting alarms. Refer to Figure 208 below for an example of the Audit Log screen. On the first line you can see that on 21th-August, 2020 at 11:33:11, PowerLossFault signal was acknowledged. This was the result of addressing an Alarm signal and clearing the Alarm. On the 7th-August, 2020 at 09:31:31 a technician changed the P1 Unload pressure from 8.27 bar to a new value of 7.58 bar.

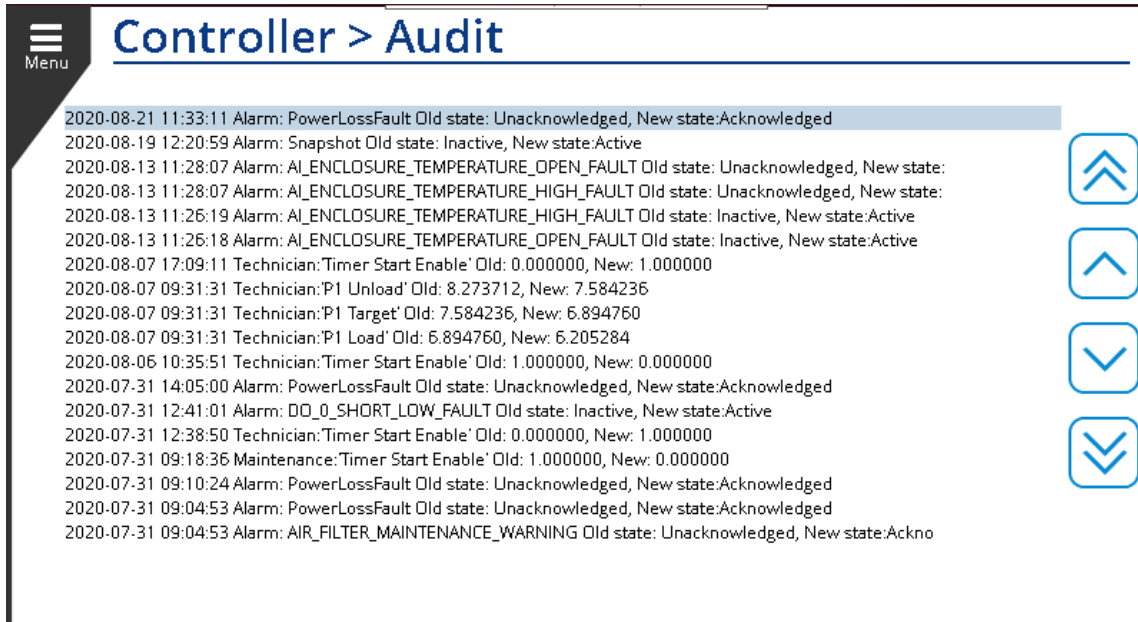

Figure 208: Audit

6.4.6 Logger:

This **Logger** page is a shortcut to the **Logger** tab in **Controller System** section. We saw the list of log from various modules under **Section 6.4.3**. This screen facilitates the user to read the logs from a specific logger. Figure 209 below represents the **Logger** screen. Note that this page should be used only when directed by Gardner Denver service.

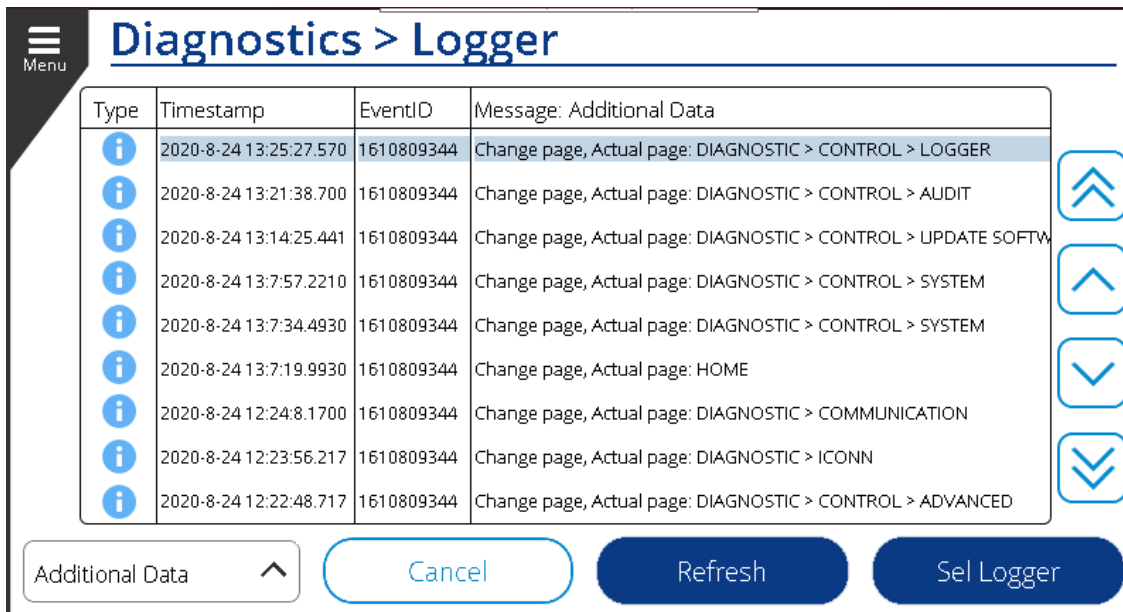

Figure 209: Logger

To select a logger, hit the **Sel Logger** button on the bottom right side. It will open up the list of all the loggers the system created. Refer Figure 210 below.

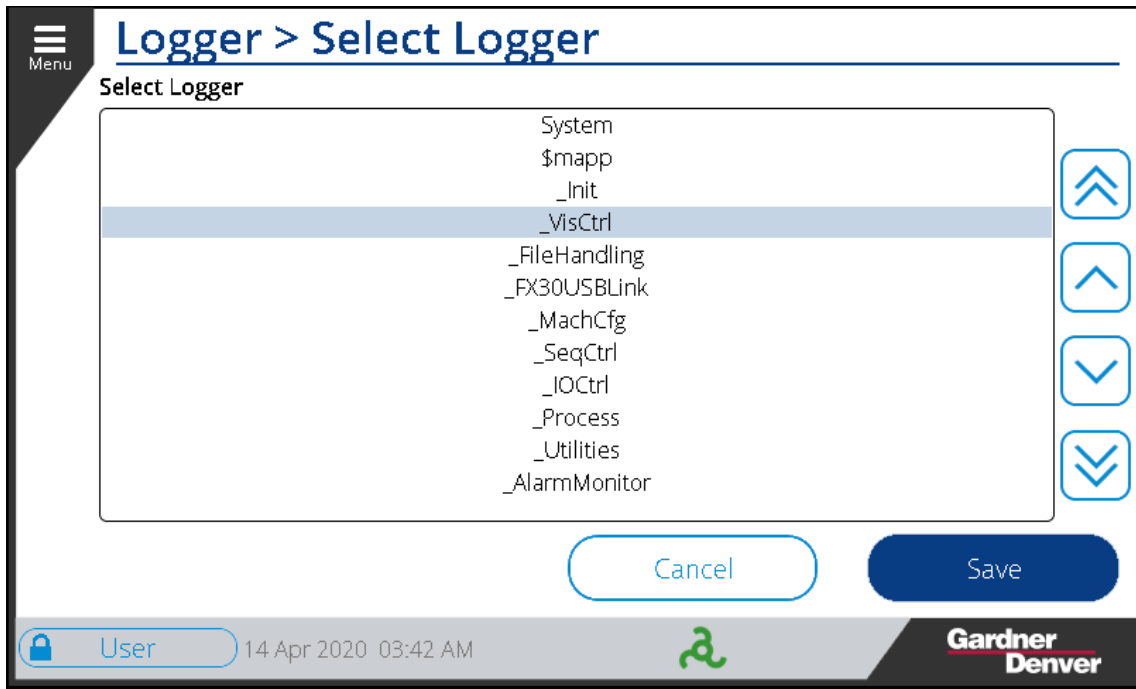

Figure 210: Select Logger

Once selected, hit the **Save** button. Another window will open showing that it is loading data from the selected logger as shown in Figure 211 below.

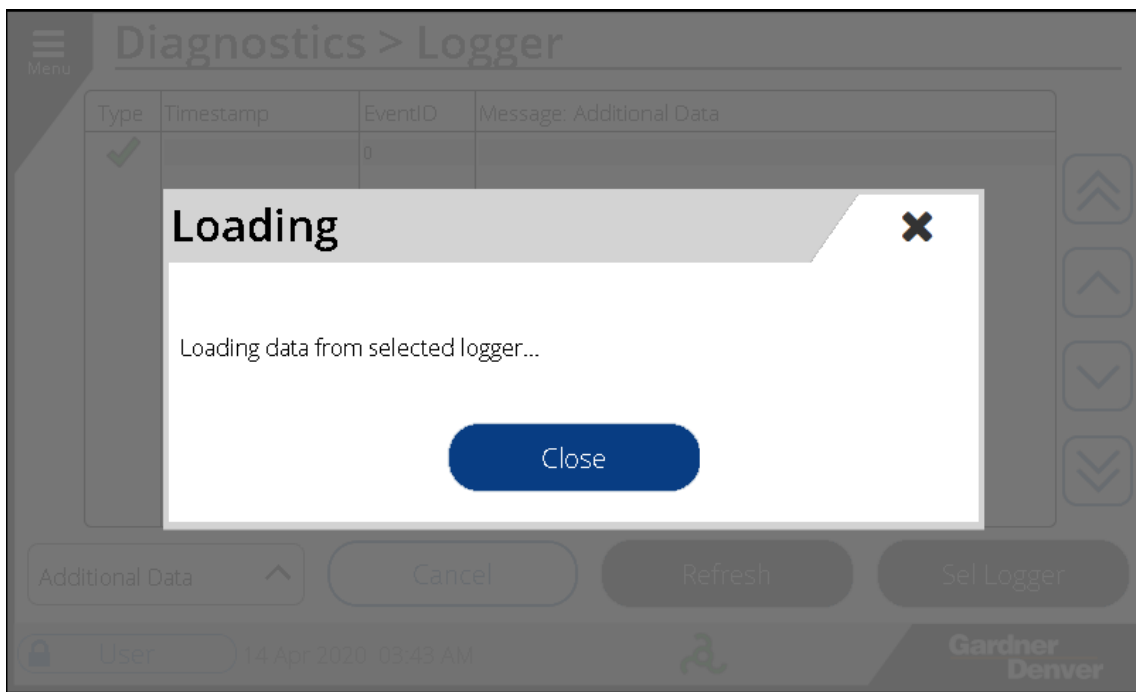

Figure 211: Data Loading from Logger

Hit the **Close** button and it will take you to the **Logger** home screen. It might take few minutes to load and display the data. Left to the **Sel Logger** there is a **Refresh** button. Hit the **Refresh** button if you want to update the log list, note, it will refresh the logs for the currently selected logger only.

6.4.7 Advanced:

The **Advanced** screen of the controller lists the number of files and their sizes in kB for each folder. Figure 212 below shows the **Advanced Controller** screen.

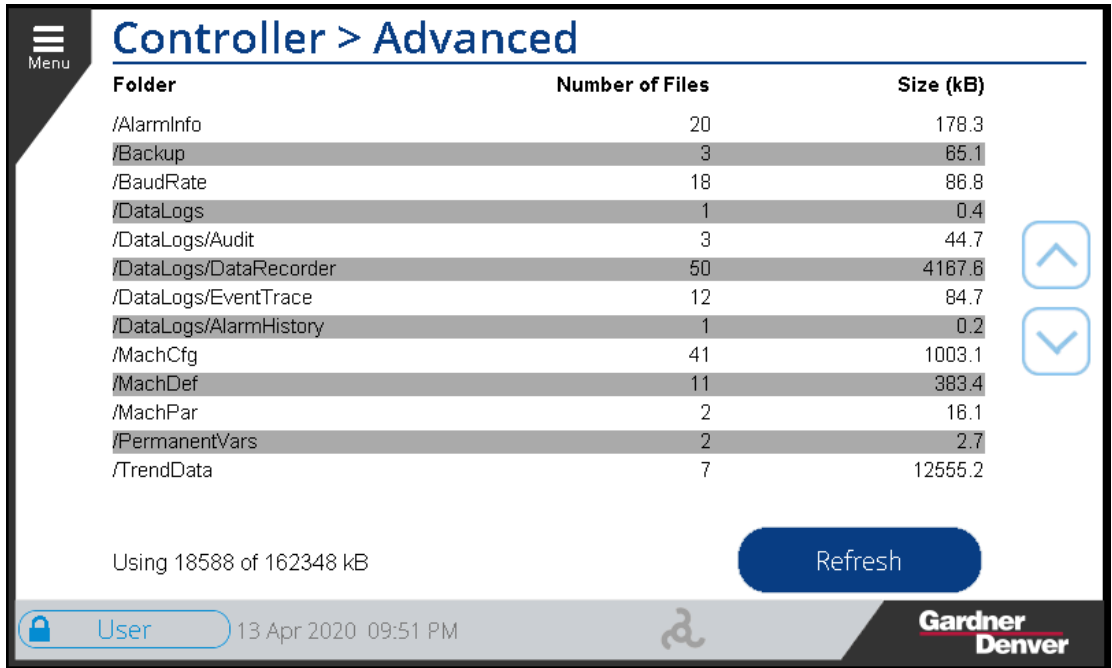

Figure 212: Advanced

As you can see, for Alarm info there are total of 20 files with 178.3 kB of memory size. You can scroll through the list using up and down navigation. The bottom left side of the screen shows how much memory is being used in the system. In the above figure, 18588 kB of system memory is used of the 162348 kB available. To refresh the list hit the refresh button on the bottom right side of the page. A confirmation dialogue box will show up displaying the total number of folders and their loading status. Refer Figure 213 below. Note the system will automatically manage the amount of free space available and delete old files as necessary.

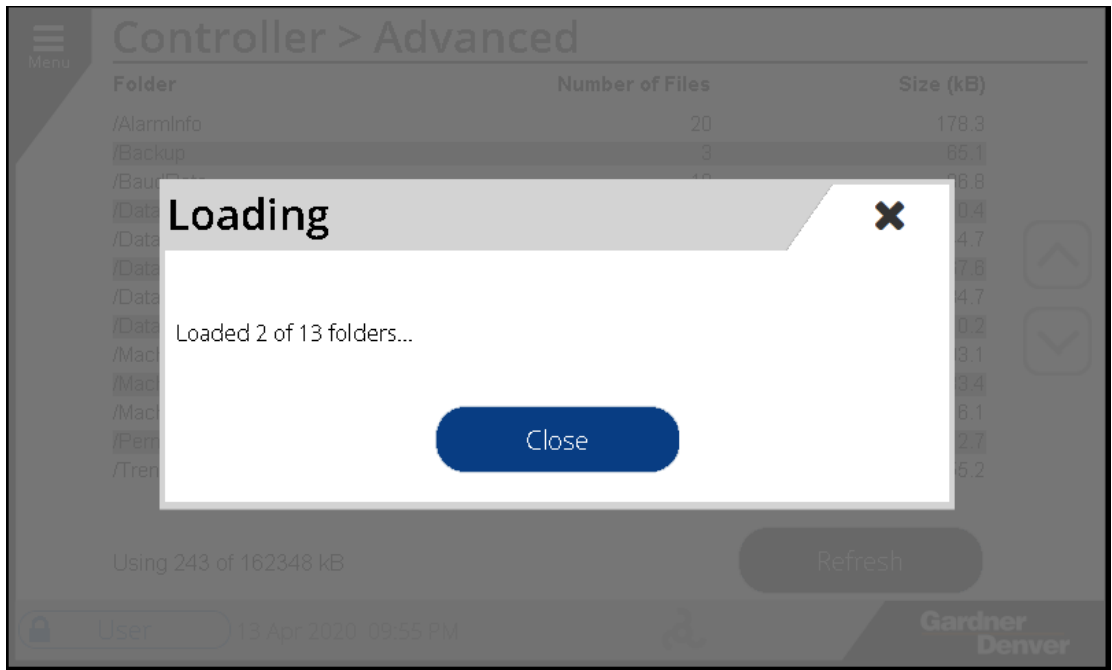
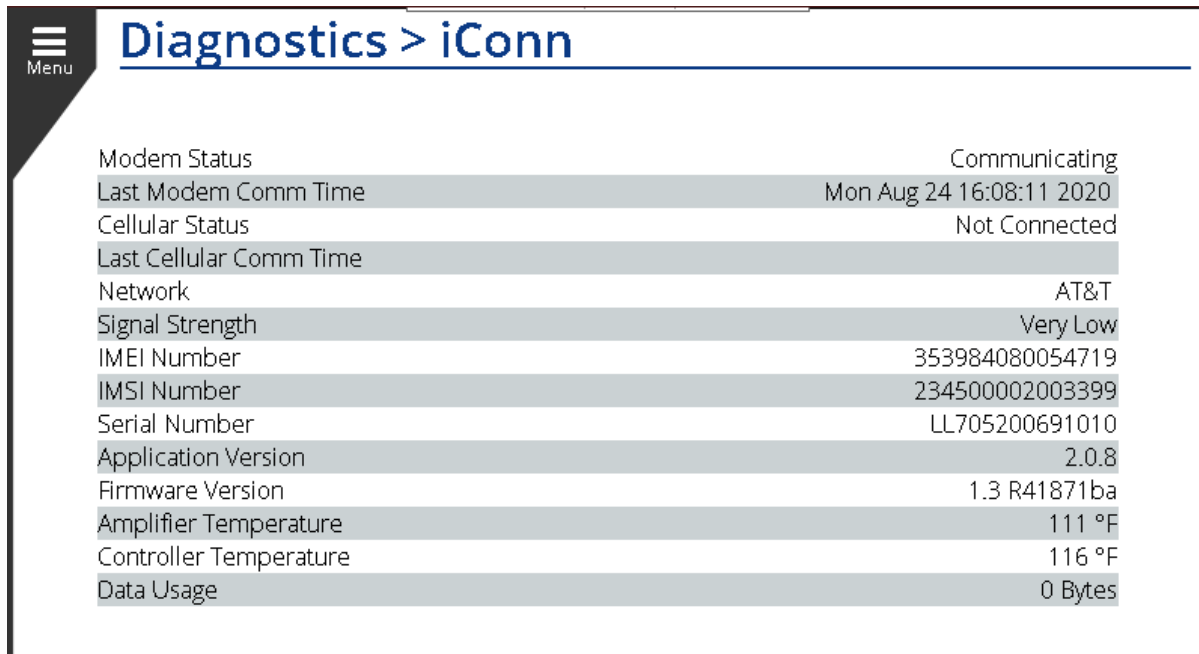

Figure 213: Advanced

6.5 iConn

iConn is a remote connectivity systems which enables the unit to be connected over the cellular network. The **iConn** diagnostics page shows the operating status and information about the **iConn** module. If the **iConn** is connected to the controller but you are having issues with operation, refer to this screen first for diagnostics information. For example, a poor cellular signal can lead to connection loss with the **iConn** server.

Example Figure 214 shows an **iConn** connected to a machine but the cellular status is not connected.



The screenshot shows a web interface for 'Diagnostics > iConn'. On the left is a 'Menu' icon. The main content is a table with alternating light and dark gray rows. The table lists various system parameters and their current values.

Diagnostics > iConn	
Modem Status	Communicating
Last Modem Comm Time	Mon Aug 24 16:08:11 2020
Cellular Status	Not Connected
Last Cellular Comm Time	
Network	AT&T
Signal Strength	Very Low
IMEI Number	353984080054719
IMSI Number	234500002003399
Serial Number	LL705200691010
Application Version	2.0.8
Firmware Version	1.3 R41871ba
Amplifier Temperature	111 °F
Controller Temperature	116 °F
Data Usage	0 Bytes

Figure 214: iConn

6.6 Communication

The **Communication** diagnostics screen displays the status of the *RS485-1* & *RS485-2* channels. As shown in Figure 215 below, each RS485 network shows a *Mode*, *Rx Count*, *Tx Bytes*, and *Rx/Tx toggle Status* indicators. Here the user can see if the communication ports are sending and receiving data, represented by the count columns. Note that it is not possible to monitor *RS485-0* through this page.

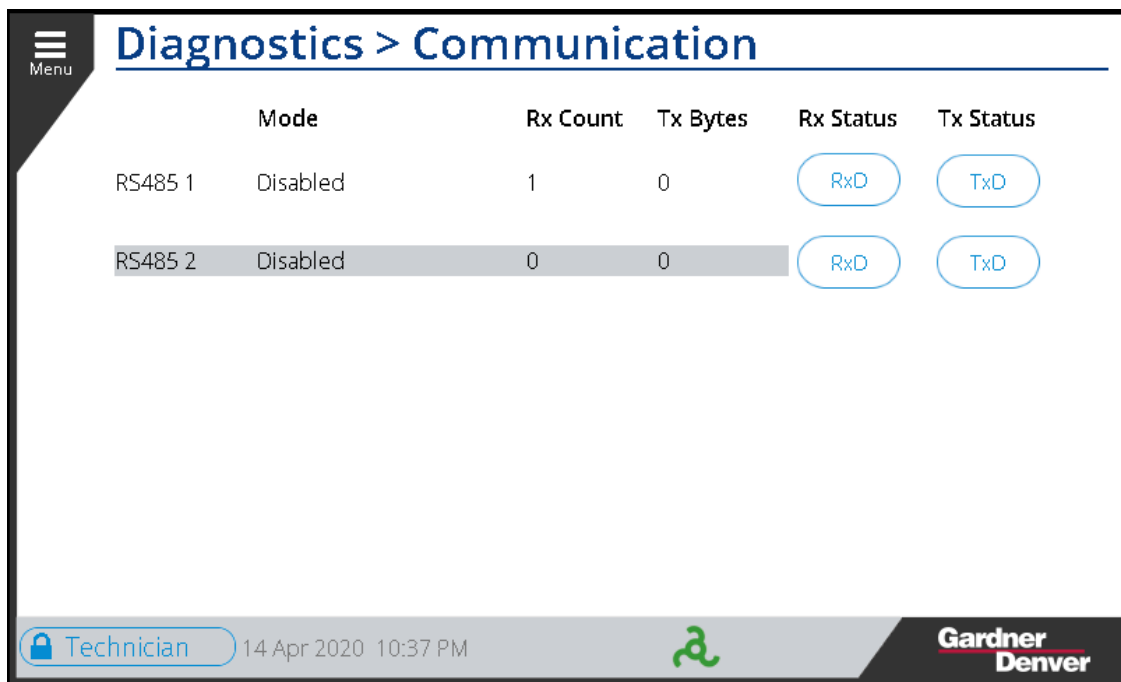

Figure 215: Communication

6.7 Remote Control

The **Remote Control** diagnostics page is a diagnostics page which shows the current status of all available remote control input signals. These parameters and their brief descriptions are listed below in Table 49.

Table 49: Remote Control

Remote Control	
Signal Name	Brief Description
Remote Halt	If active machine will stop, mode can be immediate or timed for the unload sequence
Remote Halt Enable	If assigned and active, remote halt input will function, If assigned and not active, remote halt input will be ignored, If not assigned, remote halt input will be treated as active.
Remote Load	If assigned and active, compressor loads immediately if discharge pressure is below the unload pressure. If assigned and inactive, compressor unloads immediately
Remote Load Enable	If assigned and active, remote load input is enabled, if assigned and not active, remote load input is ignored.
Remote Timer Override	If assigned and active, the timer start functionality will be overridden so that the machine will operate regardless of a start/stop timer schedule.
Secondary Pressure Activate	If active the secondary pressure band will be activated, if not active the secondary pressure band is ignored.
Active Regulation	If active, normal pressure regulation is active, if assigned and not active, compressor will begin unload sequence.
Active Regulation Enable	If assigned and active the active regulation input is followed, if assigned and not active the active regulation input is ignored.
Active Capacity Limit	If assigned and active the capacity limits set on the HMI will be enabled, if not active the limits will be ignored. When active, the speed of the compressor motor will be limited.
Inlet Modulation Mode	If active, inlet modulation is forced to disabled and machine is run in load/unload, if assigned and not active, inlet modulation is enabled overriding the setting selected on the HMI.

TV Full open	When active, turn valve is forced to a fully open position
TV Full close	When active, turn valve is forced to a fully closed position operating at full flow.
Remote Speed Control	An analog input that will control the percent load of a machine when the speed control source is set to remote.

For each parameter there are two statuses. **I/O Status** and **Communication Status**.

I/O Status:

The **I/O Status** is shown as *ON* or *OFF* for each of the parameters. If toggled *ON* it means the digital input assigned to this function is *active*. Note that this could mean that the physical input is high or low depending on configuration of the input.

Communication Status:

The **Communication Status** is shown with either *ON* or *OFF*. If toggled *ON* it indicates that the bit representing this function in the communication interface is *active*.

Figure 216 below shows an example of the **Remote Control** page.

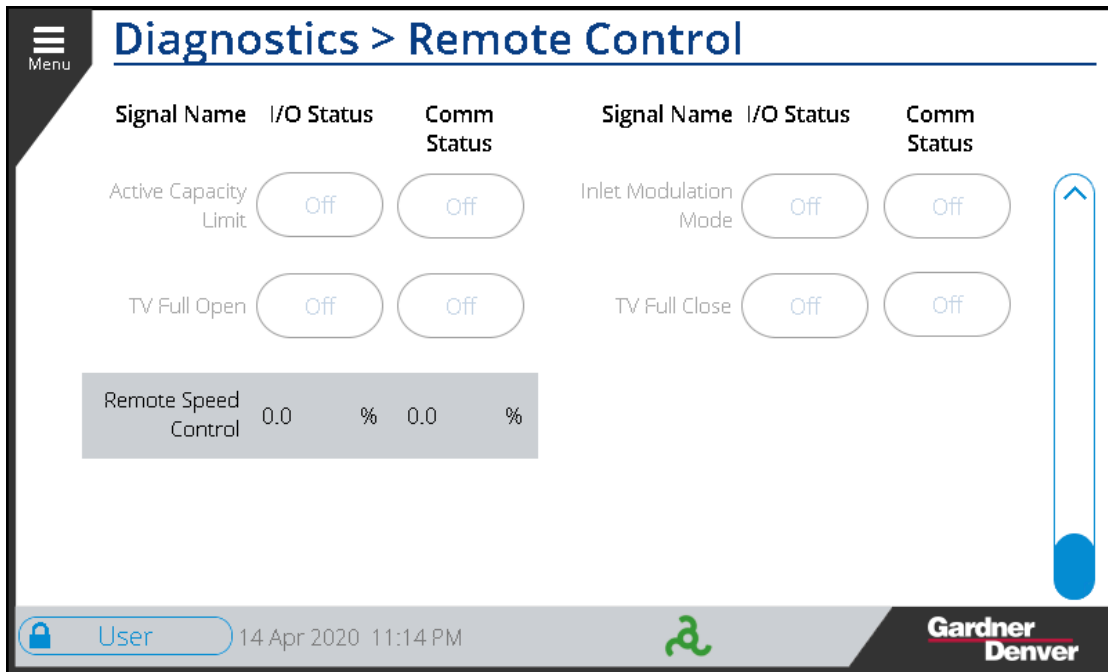

Figure 216: Remote Control

6.8 VFD Diagnostics

The **VFD Diagnostics** page lists information specific to the variable frequency drive connected to the machine. There is also important motor data listed here, as shown in Figure 217 below.

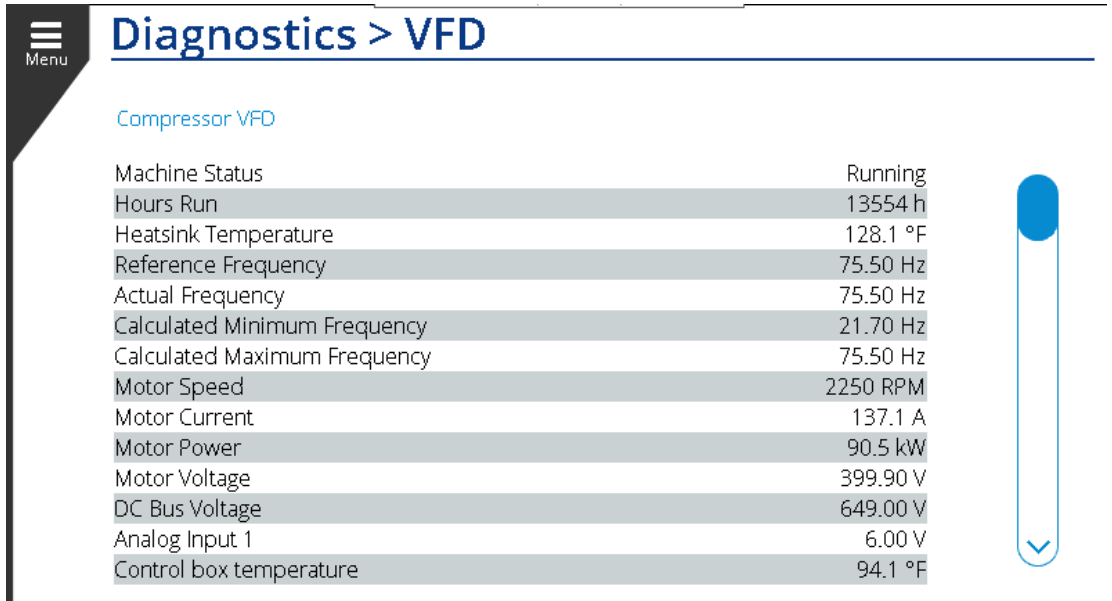

Figure 217: VFD Diagnostics

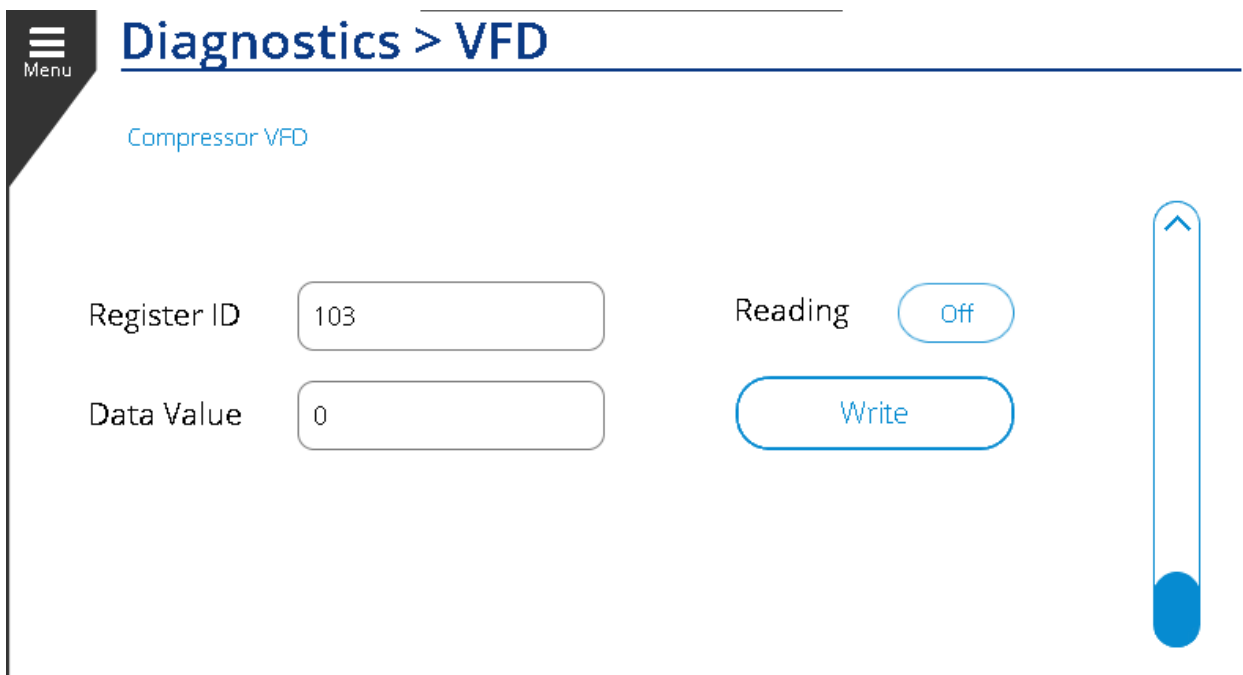

Figure 218: VFD Diagnostics

SECTION 7

TRENDS

The **Trends** screen shows data on the operation of the machine over time. The **Trends** screen is shown in Figure 219, *Delivery Pressure* and *Discharge Temp* are shown along the left and right y-axis respectively, with time across the x-axis.

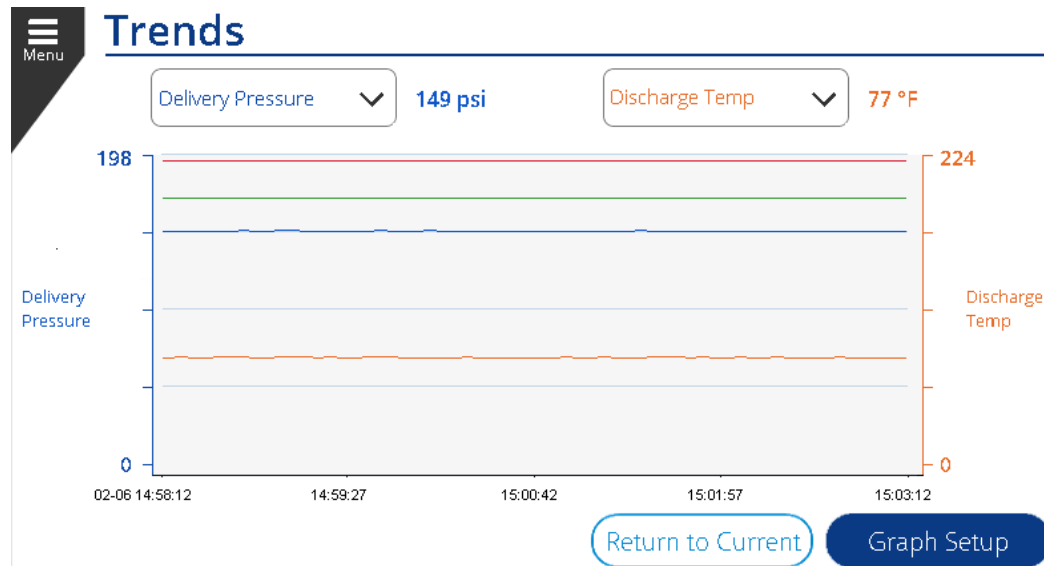

Figure 219: Trends Display

The graph allows you to display any two available parameters by changing the selection in the two dropdowns. The left dropdown changes the left y-axis of the graph and the right dropdown changes the right y-axis on the graph. The value shown next to the dropdown box is the value of the currently selected parameter. The available parameters for each dropdown are shown in Figure 220 and Figure 221 below. Notice the selections that do not apply to the machine configuration will be greyed out (as shown with **Fan Motor Speed** in the examples).

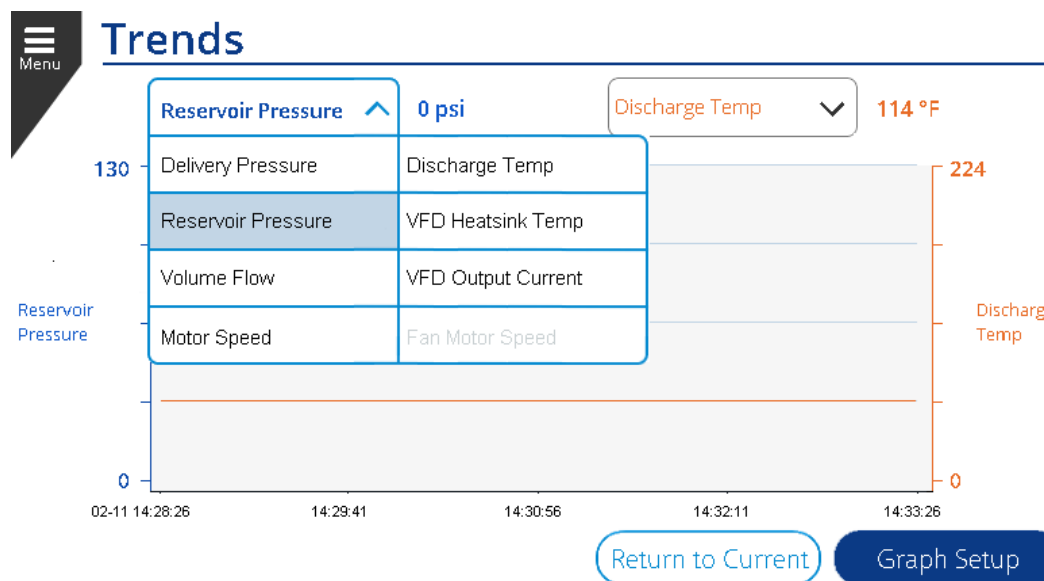

Figure 220: Trend Left Dropdown

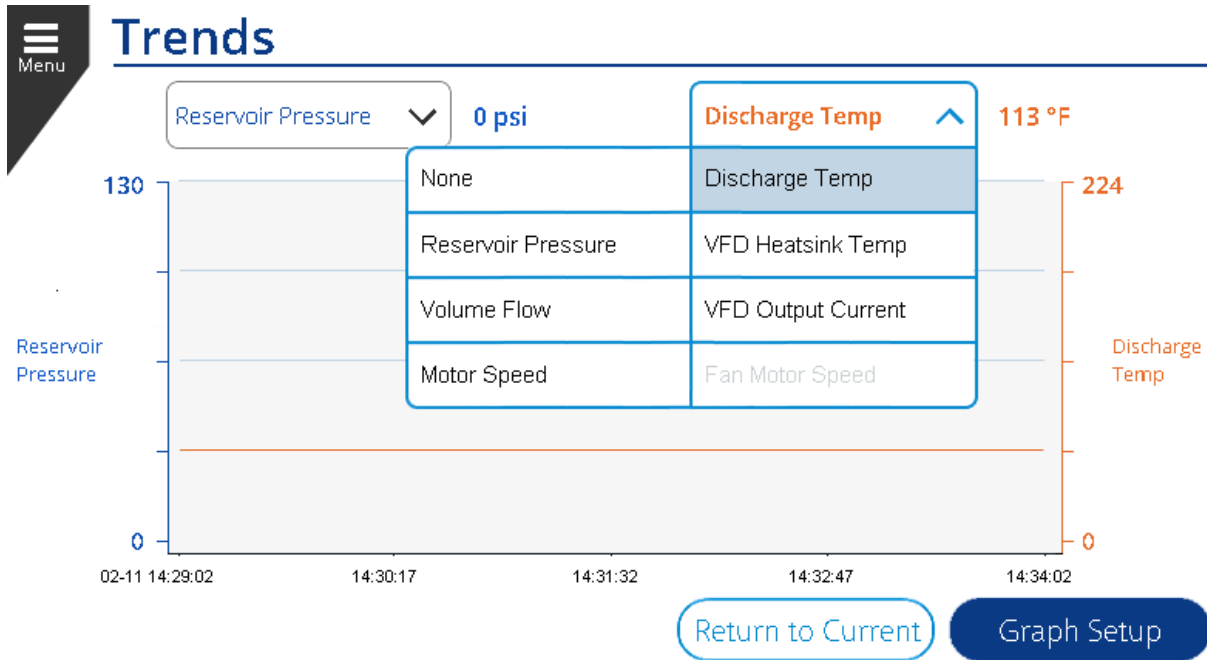

Figure 221: Trend Right Dropdown

The trends on the controller keep up to 30 days of data. To examine historical readings, press anywhere within the graph and a cursor will be activated for a History View. This is shown in Figure 222.

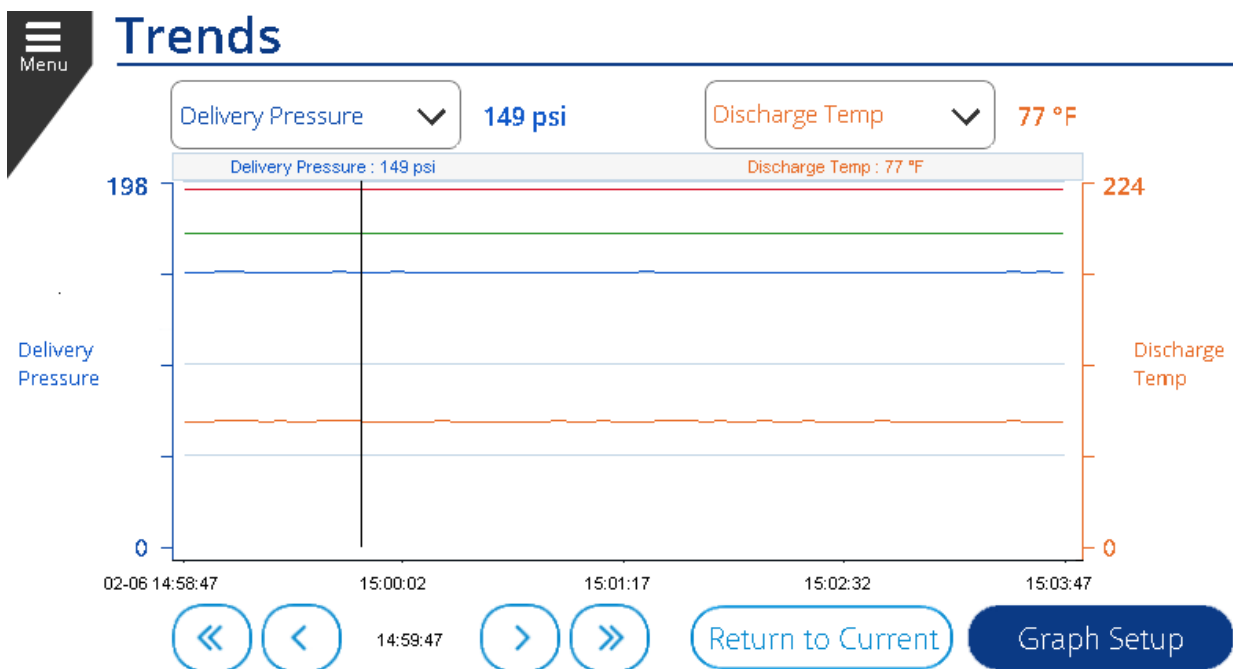

Figure 222: Trend History View

While the History view is activated, you can use the arrows to scroll forward and backward in time. The black vertical bar on the display shows the current position of the cursor and the readings just above the graph show the values at the location of the cursor. Press **Return to Current** to return to the Live Data view.

Additional configurations of the graph can be done by pressing the **Graph Setup** button. This will bring up a configuration popup as shown in Figure 223.

- The upper and lower limits of each axis can be configured to change the scale of the graph.
- The **Time Span** dropdown can be used to change the scale of the time axis. For example, setting to 12 hours would scale the graph so that the full width of the window represents 12 hours of time.
- To jump to a particular date and time in history view, press the **Edit** button next to the Date / Time and enter the date and time that you would like to view. This can be more efficient than scrolling on the graph and allows precise review of a moment in time during machine operation.

Graph Setup ✕

Zoom

Left Axis Upper Limits:	130	psi	Right Axis Upper Limits:	224	°F
Left Axis Lower Limits:	0	psi	Right Axis Lower Limits:	0	°F

Date / Time: 02/11/2019 01:27 PM Edit Time Span: 12 Hours ^

300 s	1 Hour
3 Hours	6 Hours
12 Hours	

Cancel

Figure 223: Trend Graph Setup

SECTION 8

WEB INTERFACE

The controller HMI may be viewed as a web interface from a remote location on an internet browser. This allows monitoring of the compressor when away from the physical machine. All that is needed is the *IP Address* from the *Settings > Configuration > Communication* menu under the *Ethernet* tab.

Enter the IP address into a web browser with *':81'* at the end to specify port 81. The web interface will look like Figure 224, below. As seen in the figure, the web interface shows the user the pressure and temperature limits, with current pressure and temperature readings on the gauges for the machine being monitored.

There is also a list of active alarms and alarm history for the machine. The hours left to service, loaded hours, and total run hours are listed here as well on the right side of the interface. Lastly, there are indicators for remote halt, timer control, and auto restart.

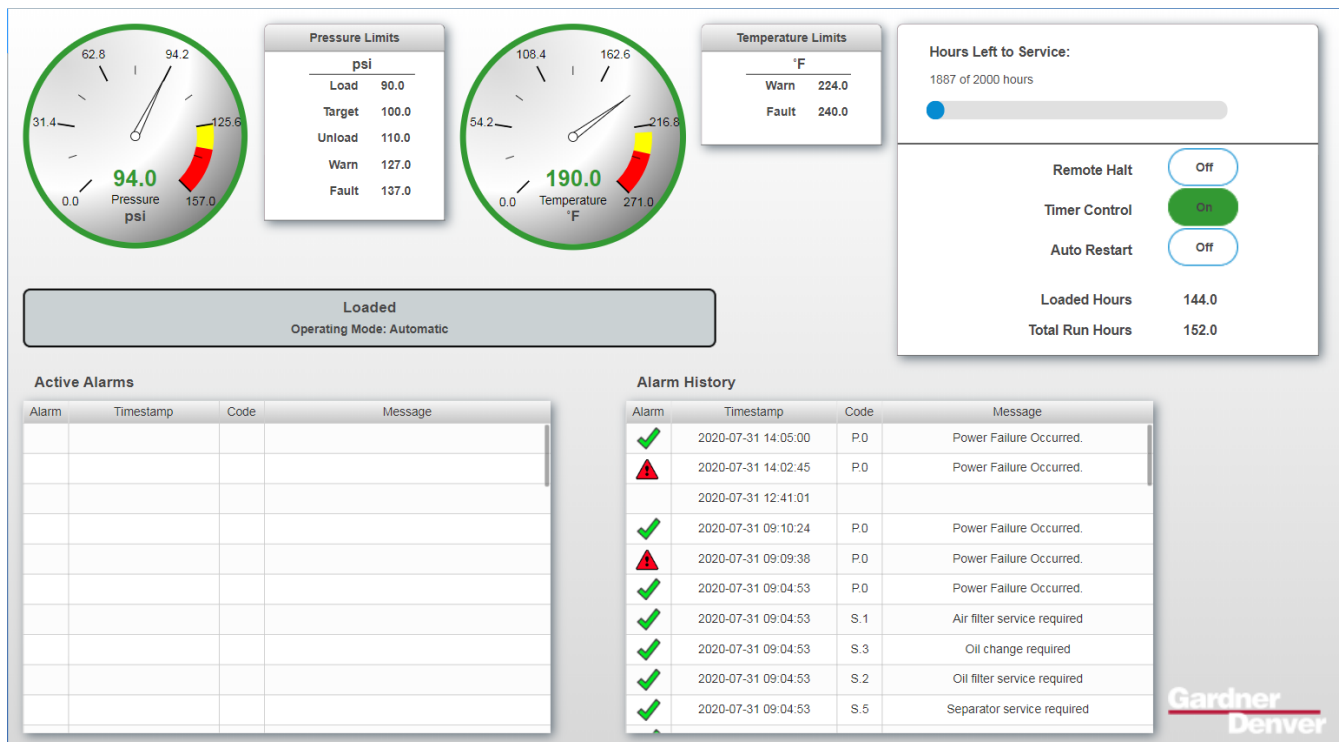

Figure 224: Web Interface

Page left blank intentionally.

Gardner Denver®

For additional information, contact your local representative or visit:
www.contactgd.com/compressors

©2019 Gardner Denver, Inc. Printed in U.S.A.

