



RHP SERIES HIGH PRESURE REFRIGERATED DRYERS

**MODELS: RHP0300, RHP0500, RHP0750, RHP1000,
RHP1250, RHP1750, RHP2000, RHP3000, RHP3750**

Contents

GENERAL SAFETY INFORMATION	2
RECEIVING, MOVING, UNPACKING	2
1.0 INSTALLATION	3
2.0 OPERATION	5
3.0 MAINTENANCE	5
SIZING	6
ENGINEERING DATA	7,8
ELECTRICAL SCHEMATICS	9
CONTROL TRANSFORMER CONNECTIONS.....	10
DIMENSIONS / WEIGHTS	11
TROUBLESHOOTING	12
PARTS LIST	13-15
WARRANTY	16

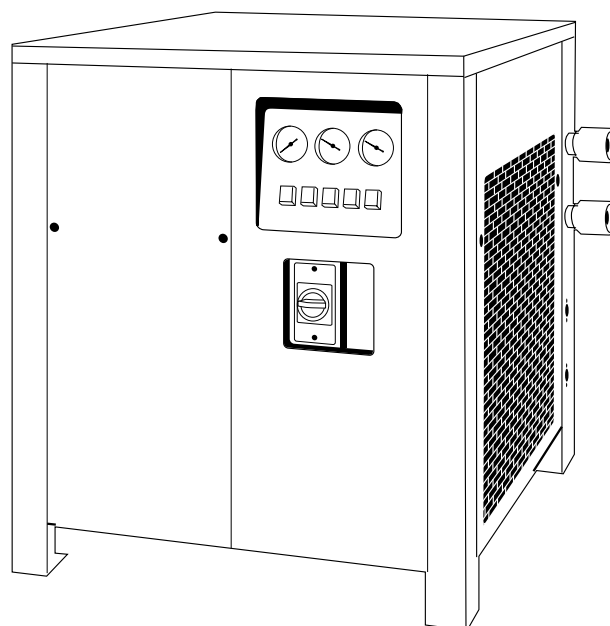

GENERAL SAFETY INFORMATION

1. PRESSURIZED DEVICES:

This equipment is a pressure containing device.



- Do not exceed maximum operating pressure as shown on equipment serial number tag.
- Make sure equipment is depressurized before working on or disassembling it for service.

2. ELECTRICAL:

This equipment requires electricity to operate.

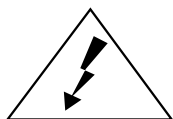

- Install equipment in compliance with all applicable electrical codes.
- Standard equipment is supplied with electrical enclosures not intended for installation in hazardous environments.
- Disconnect power supply to equipment when performing any electrical service work.

3. BREATHING AIR:

- Air treated by this equipment may not be suitable for breathing without further purification. Refer to applicable standards and specifications for the requirements for breathing quality air.



RECEIVING, MOVING, AND UNPACKING

A. RECEIVING

This shipment has been thoroughly checked, packed and inspected before leaving our plant. It was received in good condition by the carrier and was so acknowledged.

Check for Visible Loss or Damage. If this shipment shows evidence of loss or damage at time of delivery to you, insist that a notation of this loss or damage be made on the delivery receipt by the carrier's agent.

B. UNPACKING

Check for Concealed Loss or Damage. When a shipment has been delivered to you in apparent good order, but concealed damage is found upon unpacking, notify the carrier immediately and insist on his agent inspecting the shipment. Concealed damage claims are not our responsibility as our terms are F.O.B. point of shipment.

C. MOVING

In moving or transporting dryer, do not tip dryer onto its side.

D. STORAGE

IMPORTANT: Do not store dryer in temperatures above 130°F, 54.4°C.

IMPORTANT: READ PRIOR TO STARTING THIS EQUIPMENT.

1.0 INSTALLATION

1.1 Location

- A. For typical placement in a compressed air system, see drawing at right.
 - B. Air compressor intake - Locate air compressor so that contaminants potentially harmful to the dryer (e.g. ammonia) are not drawn into the air system.
 - C. Air-cooled units - Free air flow - Ambient air should be free to flow across the refrigeration condenser. Do not block either side of the cabinet.
1. Location - Locate the dryer so that the coolest ambient air possible will be drawn across the condenser.
 2. Free air flow - leave at least 36 inches (915 mm) clearance for free air flow

1.2 Mounting

- A. Mount the dryer on a firm level surface.
- B. Dryers may be bolted to the floor if desired.

NOTE: Outdoor installation: Standard dryers are designed for indoor installation. Contact manufacturer if installing outdoors.

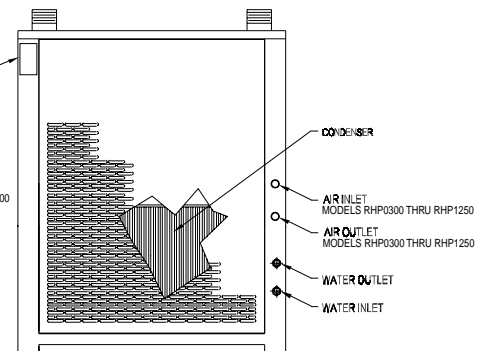
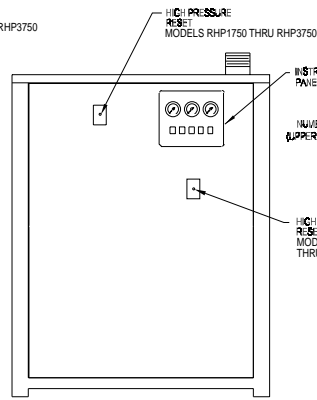
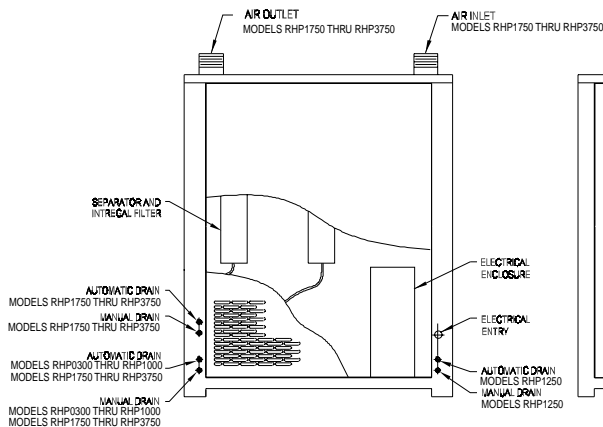
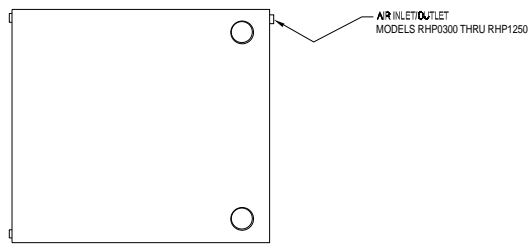
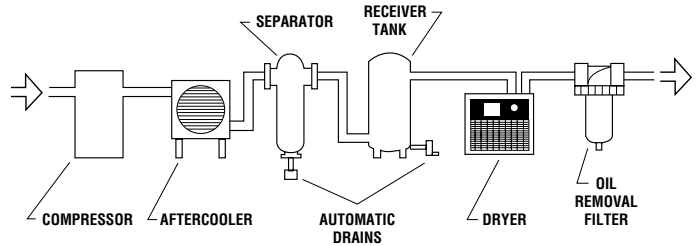

1.3 Piping connections

- A. Air Inlet - Connect compressed air line from air source to air inlet using strainer supplied. Install strainer (included in shipping carton) prior to dryer inlet.



NOTE: Observe flow direction arrows on strainer.
NOTE: Install strainer where it is easily accessible for cleaning.

NOTE: Use vibration dampening, if vibration exists in airline at inlet to dryer.

IMPORTANT: Y angle strainer must be properly installed per instruction manual to maintain dryer warranty.

IMPORTANT: Refer to Serial Number Tag for maximum working pressure. Do not exceed dryer's Maximum Working Pressure.

NOTE: Install dryer in air system at the highest pressure possible (e.g., before pressure reducing valves).

NOTE: Install dryer at coolest compressed air temperature possible. Maximum inlet compressed air temperature: 120° (49°C). If inlet air exceeds this temperature, precool the air with an aftercooler.

- B. Air Outlet - Connect air outlet to downstream air lines.
- C. By-pass piping - If servicing the dryer without interrupting the air supply is desired, piping should include inlet and outlet valves and an air by-pass valve.



D. Condensate Drain

1. Manual Drains

Dryers are shipped with ball valves for manual draining. These are loose in the cabinet and must be installed on the manual drain coupling located on the cabinet leg before pressurizing the dryer.

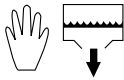

2. Automatic Drains

Drain lines can be run from Automatic Drain outlets (1) on models RHP0300 through RHP1250 or (2) on models RHP1750 through RHP3750 to plant drainage system.

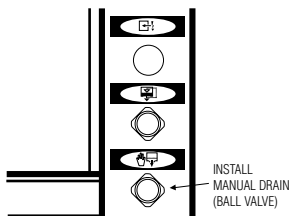

NOTE: Condensate discharge is at system pressure. Anchor drain lines to prevent whipping.

NOTE: Condensate may contain oil. Comply with applicable laws concerning proper disposal.

- E. Water cooled models - cooling water inlet and outlet
1. Connect cooling water supply to cooling water inlet coupling.
 2. Connect cooling water return line to cooling water outlet coupling.

NOTE: Strainer and water regulating valve are supplied on water cooled models.

1.4 Electrical connections

IMPORTANT-Use copper supply wires only.

- A. Unit is designed to operate on the voltage, phase, and frequency listed on serial number tag.
- B. Electrical entry is through the hole in the cabinet and into the electrical enclosure. Connect power source to the terminal strip in the electrical enclosure as shown on the Electrical Schematic.



IMPORTANT-Models RHP1250 through RHP3750 are equipped with scroll compressors. These compressors must rotate in the proper direction. It will operate backwards if phasing is not correctly connected. To determine proper rotation, connect to power source and after 24 hours start unit. If an unusual noise is heard and the suction pressure fails to drop into normal operating range as noted in ENGINEERING DATA, stop dryer, reverse two power leads, and restart. Suction pressure should now drop into normal range.

NOTE: The refrigeration condensing unit is designed to run continuously and should NOT be wired to cycle on/off with the air compressor.

1.5 Automatic condensate drains

- A. Verify that isolation valves are open.
- B. Verify time settings.
After dryer is operating, verify that valve remains open long enough for all condensate to be ejected from the system. If all condensate is not ejected during valve open time, shorten time between operations.
- C. Drain timers (1) or (2) are factory set for 5 minutes between operations (valve closed) and 5 seconds valve open time.

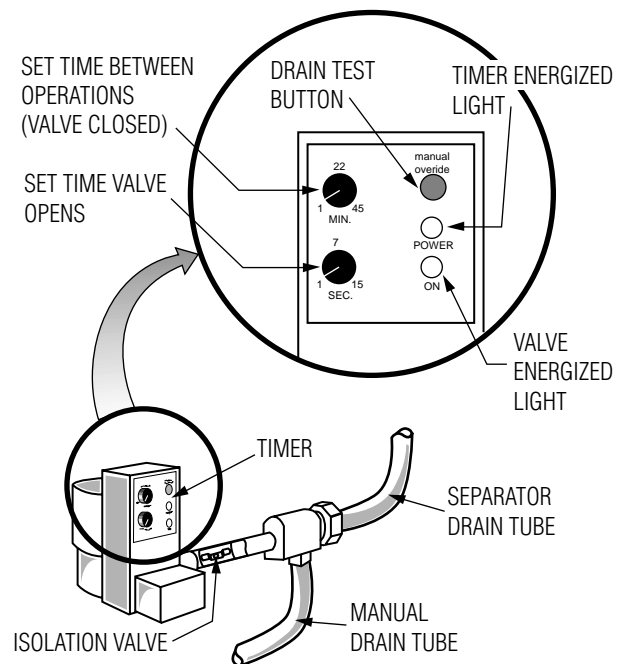

ELECTRIC ASSEMBLY

2.0 OPERATION

2.1 Minimum/maximum operating conditions

- A. Maximum inlet air pressure: 700 psig (48 barg)
- B. Minimum inlet air pressure: 15 psig (0.35 kgf/cm²)
- C. Maximum inlet air temperature: 120°F (49°C)
- D. Maximum ambient temperature:
 - Air-cooled models: 110°F (43°C)
 - Water-cooled models: 130°F (54°C)
- E. Minimum ambient temperature: 35°F (2°C)

2.2 Start-up

NOTE: DRYER MUST BE ENERGIZED 24 HOURS BEFORE STARTING REFRIGERATION COMPRESSOR

NOTE: START UNIT BEFORE INTRODUCING AIR FLOW. HIGH PRESSURE SWITCH HAS A MANUAL RESET. SWITCH MAY NEED TO BE RESET DURING START-UP.

- A. Control Panel
 1. After making sure that on/off switch is off ("O"), energize dryer. Green power-on light will glow.
 2. On water-cooled units - after 24 hours start flow of through condenser.
 3. After 24 hours, energize compressor by positioning the switch in the on ("I") position. Green compressor-on light will glow.
- B. Alarms
 1. High temperature alarm - If the Lowest Air Temperature exceeds the alarm set point, the red high temp warning light will glow.
 2. Refrigerant system cut-out alarm - If the high or low refrigerant pressure set points have been exceeded, the dryer will shut down. The green compressor-on light will turn off and the red refrigerant cut out light will glow.

NOTE: THIS ALARM CAN ALSO INDICATE HIGH DISCHARGE TEMPERATURE ON MODELS RHP1250 AND RHP1750 AND HIGH COMPRESSOR WINDING TEMPERATURE, HIGH DISCHARGE TEMPERATURE OR IMPROPER COMPRESSOR ROTATION ON MODELS RHP2000 THROUGH RHP3750.

NOTE: HIGH REFRIGERANT PRESSURE SWITCH HAS A MANUAL RESET. AFTER CORRECTION FAULT, MANUALLY RESET SWITCH TO RESUME OPERATION.

- C. Drain Test Button
Push test button on drain valve to manually activate. Drain energized light will glow.

2.3 Operating check points

Check the following on a periodic basis:

- A. Power-on light glows indicating power to the dryer.
- B. Compressor-on light (green) glows indicating the refrigerator compressor is operating.
- C. The high air temperature warning light is out. The high air temperature warning light will illuminate when unit is energized. The light should go out approximately 15

minutes after start-up. If light remains lit after 30 minutes or lights again after going out, refer to the Troubleshooting Guide.

- D. Refrigerant system cut-out light is out.
- E. Suction pressure gauge indicates proper low side refrigerant pressure.
- F. Inlet temperature gauge should read below 120°F (49°C).

3.0 MAINTENANCE

3.1 Air-cooled models -

Condenser coil - Clean off accumulated dust and dirt monthly.

3.2 Water-cooled models -

Strainer - Clean strainer periodically to prevent restriction of water flow.

3.3 Automatic condensate drains

Check daily to be sure automatic drain is discharging.

Manually drain separator weekly by using push-to-test button to energize electric drains.

3.4 Inlet air strainer

Clean inlet air strainer monthly or more often if rapid clogging occurs.

- A. Shut-off compressed air supply to strainer and depressurize dryer.
- B. Remove screen and clean or replace
- C. Re-install
- D. Repressurize dryer and resume operation.

3.5 Replace separator/filter element yearly or more often if pressure drop across dryer is excessive.

- A. Shut-off compressed air supply to separator and depressurize dryer.
- B. Remove screen and disconnect drain line from bottom of separator.
- C. Remove bowl by turning counter clockwise.
- D. Let bowl down to filter element.
- E. Remove element by rotating counter clockwise.
- F. Install new filter element and bowl with new o-rings properly seated to head.
- G. Connect drain line and replace screen.
- H. Repressurize dryer and resume operation.

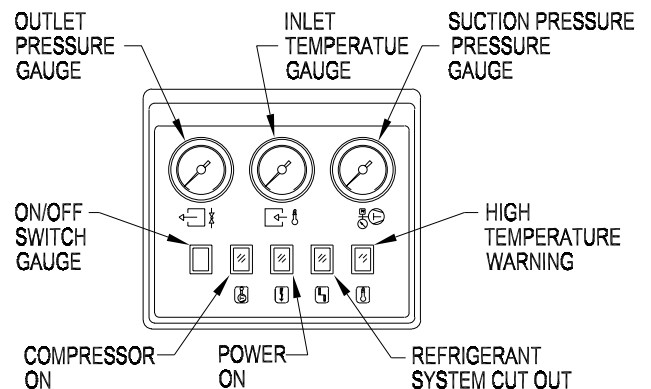

INSTRUMENT PANEL

SIZING

Determining dryer capacity

To determine the maximum inlet flow capacity of a dryer at various operating conditions, multiply the rated capacity from Table 1 by the multipliers shown in Table 2, 3, 4, & 5. Maximum capacity using all correction factors CANNOT be more than twice the rated capacity. EXAMPLE: How many scfm will a RHP0500 handle when the compressed air to be dried is at 500 psig inlet pressure and 90°F inlet temperature; 110°F ambient air temperature; 60 Hz operation; and a 38°F dew point temperature is desired?

Answer: $500 \times 1.19 \times 0.94 \times 1.00 \times 1.00 = 559$ SCFM.

TABLE 1

Rated capacity and Pressure Drop @ 700 psig inlet pressure, 100°F inlet temperature, and 100°F ambient temperature and 60 Hz operation.)

MODEL	FLOW (1)		PRESSURE DROP(1)		MWP		REFRIGERATION SYSTEM (2)		IN/OUT CONNECTION NPT/BSP (3)
	SCFM	M ³ /H	PSIG	BAR	PSIG	BAR	HP	KW	
RHP0300	300	515	4.1	0.28	700	49	1	1.1	1"
RHP0500	500	859	5.8	0.40	700	49	1.5	1.98	1"
RHP0750	750	1288	7.3	0.50	700	49	2	2.35	1-1/2"
RHP1000	1000	1717	11.8	0.81	700	49	3	3.69	1-1/2"
RHP1250	1250	2146	10.7	0.74	700	49	4	5.34	1-1/2"
RHP1750	1750	3005	9.5	0.65	700	49	6	7.65	3" or DN80
RHP2000	2000	3434	11.8	0.81	700	49	7.5	9.81	3" or DN80
RHP3000	3000	5151	11.8	0.81	700	49	10	14.06	3" or DN80
RHP3750	3750	6439	10.7	0.74	700	49	12	16.47	3" or DN80

(1) Flow and pressure drop at MWP (maximum working pressure) and at 60 Hz, 100°F inlet and 100°F ambient pressure.

(2) Figures shown are condensing unit manufacturer's published ratings @ 35°F, 2°C evaporator and 100°F, 38°C ambient.

(3) Please specify NPT or BSP

TABLE 2 - Capacity Adjustment Factor for Compressed Air Inlet Temperature and Pressure

INLET PRESSURE (psig)	INLET TEMPERATURE (°F)				
	80°F (27°C)	90°F (32°C)	100°F (38°C)	110°F (43°C)	120°F (49°C)
300 psig to MWP 20 BAR to MWP	1.49	1.19	1.00	0.83	0.72

TABLE 3 - Correction Factors for Ambient Air Temperature

AMBIENT TEMPERATURE °F (°C)	CAPACITY ADJUSTMENT FACTOR
80 (27)	1.12
90 (32)	1.06
100 (38)	1.00
110 (43)	0.94
Water-cooled (85°F, 27°C cooling water)	1.15

TABLE 4 - Correction Factors Outlet Dew Point

DEW POINT	ISO 8573.1 CLASS	FACTOR
38°F (3°C)	4	1.0
45°F (7°C)	5	1.2
50°F (10°C)	6	1.3

TABLE 5 - Correction Factors for Electrical Frequency

60 Hz	1.0
50Hz	0.83

ENGINEERING DATA

MODELS		RHP0300	RHP0500	RHP0750	RHP1000	RHP1250
MINIMUM - MAXIMUM OPERATING CONDITIONS						
Max. Inlet Air Pressure (compressed air at inlet to dryer)		700 psig (49 bar)				
Max. Inlet Air Temperature (compressed air at inlet to dryer)		120°F (49°C)				
Min.-Max. Ambient Temperature		35°F (1.7°C) - 110°F (43°C)				
Air-cooled		35°F (1.7°C) - 130°F (54°C)				
Water-cooled		35°F (1.7°C) - 130°F (54°C)				
Pressure drop inlet/outlet	psid	4.1	5.8	7.3	11.8	10.7
Inlet/outlet connection	npt(m)	1	1	1-1/2	1-1/2	1-1/2
REFRIGERATION SYSTEM DATA						
Condensing Unit Mfg		Copeland				
Compressor Type		Hermetic - Non-Cycling				
Refrigeration Compressor Horsepower		1	1-1/2	2	3	4
BTU/HR - Refrigeration Only @ 35°F (1.7°C) Evaporator & 100°F (38°C) Ambient	60 / 50 Hz	9202 / 7668	14750 / 12292	20322 / 16935	28592 / 23827	35730 / 29775
Outlet Air Temperature (nominal at rated conditions)		85°F (29°C)				
Refrigerant Type		R-134a	R-134a	R-134a	R-134a	R-404a
Refrigerant Charge		See dryer serial number tag				
Suction Pressure Setting psig (bar)		30.5 (2.1)	30.5 (2.1)	30.5 (2.1)	30.5 (2.1)	78 (5.4)
Compressor Control Ranges (psig) (out-in)	A/C High	281-190	281-190	281-190	281-190	450-350
	A/C Low	24-34	24-34	24-34	24-34	84-67
Compressor Control Ranges (psig) (out-in)	W/C High	200-160	200-160	200-160	200-160	320-280
	W/C Low	24-34	24-34	24-34	24-34	84-67
Condenser Fan Switch Setting (in-out)(psig)	Fan 1	113-78	113-78	113-78	113-78	300-230
(air-cooled models)	Fan 2	-	-	183-124	183-124	-
Air Flow Across Condenser (cfm)	60 / 50 Hz	672 / 560	1093 / 911	2650 / 2208	2650 / 2208	2725 / 2271
CONDENSER COOLING WATER REQUIREMENTS (water-cooled models)						
Recommended Water Pressure psig (bar)*		40 (2.8) Min. - 120 (8.4) Max*.				
Gallons Per Minute Of Flow Required With 85°F Cooling Water 60 / 50 Hz		2.9 / 2.4	4.8 / 4.0	5.8 / 4.8	8.2 / 6.8	12 / 10
ELECTRICAL						
Nominal Voltage						
208-230/3/60						
Max. - Min. voltage		253-187	253-187	253-187	253-187	253-187
Amperage Draw Total Full Load**		8.4	11.5	13.6	22.9	19.1
Compressor Rated Load (amps)		7.5	10.4	11.4	20.7	15
Compressor Locked Rotor (amps)		51	65.5	75	90	99
Unit Protection Fuse Size (amps)**		10	12-1/2	15	25	20
Branch Circuit Fuse Size (amps) Max. ***		15	20	25	45	35
Watts @ 35°F (1.7°C) Evaporator & 100°F (38°C) Ambient		1335	1940	2620	3600	5375
Resistance (ohms)	Three phase (total)	1.77	1.256	1.058	0.853	-
Nominal Voltage						
460/3-60						
Max. - Min. Voltage		506-414	506-414	506-414	506-414	506-414
Amperage Draw Total Full Load***		4.0	5.4	6.2	11	10.3
Compressor Rated Load (amps)		3.59	4.7	5.1	9.9	8.2
Compressor Locked Rotor (amps)		25	33	40	45	49.5
Unit Protection Fuse Size (amps)**		5	7-1/2	7-1/2	12-1/2	12-1/2
Branch Circuit Fuse Size (amps) Max. ***		10	10	10	20	20
Watts @ 35°F Evaporator & 100°F Ambient		1335	1940	2620	3600	5375
Resistance (ohms)	Three phase (total)	7.44	4.95	4.11	0.853	-
Nominal Voltage						
200-220/3/50						
Max. - Min. Voltage		242-180	242-180	242-180	242-180	242-180
Amperage Draw Total Full Load **		8.4	11.5	13.6	22.9	19.1
Compressor Rated Load (amps)		7.5	10.4	11.4	20.7	15
Compressor Locked Rotor (amps)		51	65.5	75	90	99
Unit Protection Fuse Size (amps)**		10	12-1/2	15	25	20
Branch Circuit Fuse Size (amps) Max. ***		15	20	25	45	35
Watts @ 35°F (1.7°C) Evaporator & 100°F (38°C) Ambient		1004	1459	1970	2929	4479
Resistance (ohms)	Three phase (total)	7.44	4.95	4.11	0.853	-
Nominal Voltage						
400/3/50						
Max. - Min. Voltage		462-342	462-342	462-342	462-342	462-342
Amperage Draw Total Full Load **		4.0	5.4	6.2	11	10.3
Compressor Rated Load (amps)		3.59	4.7	5.1	9.9	8.2
Compressor Locked Rotor (amps)		25	33	40	45	49.5
Unit Protection Fuse Size (amps)**		5	7-1/2	7-1/2	12-1/2	12-1/2
Branch Circuit Fuse Size (amps) Max. ***		10	10	10	20	20
Watts @ 35°F (1.7°C) Evaporator & 100°F (38°C) Ambient		1004	1459	1970	2929	4479
Resistance (ohms)	Three phase (total)	7.44	4.95	4.11	0.853	-
Nominal Voltage						
575/3/60						
Max. - Min. Voltage		632-518	632-518	632-518	632-518	632-518
Amperage Draw Total Full Load **		4.0	5.4	6.2	11	9.8
Compressor Rated Load (amps)		3.59	4.7	5.1	9.9	8.2
Compressor Locked Rotor (amps)		25	33	40	45	40
Unit Protection Fuse Size (amps)**		5	7-1/2	7-1/2	12-1/2	12-1/2
Branch Circuit Fuse Size (amps) Max. ***		10	10	10	20	20
Watts @ 35°F (1.7°C) Evaporator & 100°F (38°F) Ambient		1335	1940	2620	3600	5375
Resistance (ohms)	Three phase (total)	7.44	4.95	4.11	0.853	-

* Allows continued operation with some restriction in the water strainer

** Air-cooled models only

*** HACR type per NEC

ENGINEERING DATA

MODELS	RHP1750	RHP2000	RHP3000	RHP3750	
MINIMUM - MAXIMUM OPERATING CONDITIONS					
Max. Inlet Air Pressure (compressed air at inlet to dryer)	700 psig (49 bar)				
Max. Inlet Air Temperature (compressed air at inlet to dryer)	120°F (49°C)				
Min. -Max. Ambient Temperature					
Air-cooled	35°F (1.7°C) - 110°F (43°C)				
Water-cooled	35°F (1.7°C) - 130°F (54°C)				
Pressure drop inlet/outlet	psid	10.4	11	11.6	10.1
Inlet/outlet connection	npt(m)	3	3	3	3
REFRIGERATION SYSTEM DATA					
Condensing Unit Mfg	Copeland				
Compressor Type	Hermetic - Non-Cycling				
Refrigeration Compressor Horsepower	6	7.5	10	12	
BTU/HR - Refrigeration Only @ 35°F (1.7°C) Evaporator & 100°F (38°C) Ambient	60 / 50 Hz	52700 / 43916	63030 / 52525	90240 / 75200	109900 / 91583
Outlet Air Temperature (nominal at rated conditions)	85°F (29°C)				
Refrigerant Type	R-404A	R-404A	R-404A	R-404A	
Refrigerant Charge	See dryer serial number tag				
Suction Pressure Setting psig (bar)	78 (5.4)	78 (5.4)	78 (5.4)	78 (5.4)	
Compressor Control Ranges (psig) (out-in)	A/C High A/C Low	450-350 84-67	450-350 84-67	450-350 84-67	450-350 84-67
Compressor Control Ranges (psig) (out-in)	W/C High W/C Low	320-280 84-67	320-280 84-67	320-280 84-67	320-280 84-67
Condenser Fan Switch Setting (in-out)(psig) (air-cooled models)	Fan 1 Fan 2	300-230 325-255	300-230 325-255	300-230 325-255	300-230 325-255
Air Flow Across Condenser (cfm)	60 / 50 Hz	4237 / 3531	4900 / 4083	4900 / 4083	4900 / 4083
CONDENSER COOLING WATER REQUIREMENTS (water-cooled models)					
Recommended Water Pressure psig (bar)*	40 (2.8) Min. - 120 (8.4) Max*.				
Gallons Per Minute Of Flow Required With 85°F Cooling Water 60 / 50 Hz	14 / 12	21 / 18	27 / 23	35 / 30	
ELECTRICAL					
Nominal Voltage					
208-230/3/60					
Max. - Min. voltage	253-187	253-187	253-187	253-187	
Amperage Draw Total Full Load**	26.9	39.3	53.1	62.8	
Compressor Rated Load (amps)	23.9	30.9	44.9	54.4	
Compressor Locked Rotor (amps)	156	189	278	350	
Unit Protection Fuse Size (amps)**	30	45	60	70	
Branch Circuit Fuse Size (amps) Max. ***	50	70	100	125	
Watts @ 35°F (1.7°C) Evaporator & 100°F (38°C) Ambient	6221	9623	12250	16025	
Resistance (ohms) Three phase (total)	-	-	-	-	
Nominal Voltage					
460/3-60					
Max. - Min. voltage	506-414	506-414	506-414	506-414	
Amperage Draw Total Full Load**	15.4	20	25.5	29.6	
Compressor Rated Load (amps)	11.8	16.2	21.7	25.8	
Compressor Locked Rotor (amps)	70	94	127	158	
Unit Protection Fuse Size (amps)**	15	25	30	35	
Branch Circuit Fuse Size (amps) Max. ***	20	40	50	60	
Watts @ 35°F (1.7°C) Evaporator & 100°F (38°C) Ambient	6221	9623	12250	16025	
Resistance (ohms) Three phase (total)	-	-	-	-	
Nominal Voltage					
200-220/3/50					
Max. - Min. Voltage	242-180	242-180	242-180	242-180	
Amperage Draw Total Full Load***	30.8	39.3	53.1	62.8	
Compressor Rated Load (amps)	27.2	30.9	44.9	54.4	
Compressor Locked Rotor (amps)	156	189	278	350	
Unit Protection Fuse Size (amps)**	30	45	60	70	
Branch Circuit Fuse Size (amps) Max. ***	50	70	100	125	
Watts @ 35°F Evaporator & 100°F Ambient	5184	8019	10208	13354	
Resistance (ohms) Three phase (total)	-	-	-	-	
Nominal Voltage					
400/3/50					
Max. - Min. Voltage	462-342	462-342	462-342	462-342	
Amperage Draw Total Full Load **	15.4	20	25.5	29.6	
Compressor Rated Load (amps)	13.6	16.2	21.7	25.8	
Compressor Locked Rotor (amps)	74	99	127	167	
Unit Protection Fuse Size (amps)**	15	25	30	35	
Branch Circuit Fuse Size (amps) Max. ***	20	40	50	60	
Watts @ 35°F (1.7°C) Evaporator & 100°F (38°C) Ambient	5184	8019	10208	13354	
Resistance (ohms) Three phase (total)	-	-	-	-	
Nominal Voltage					
575/3/60					
Max. - Min. Voltage	632-518	632-518	632-518	632-518	
Amperage Draw Total Full Load **	9.3	15.2	20	24	
Compressor Rated Load (amps)	7.9	11.8	16.6	20.6	
Compressor Locked Rotor (amps)	54	74	100	125	
MODELS					
Unit Protection Fuse Size (amps)**	6	7.5	10	12	
Branch Circuit Fuse Size (amps) Max. ***	12-1/2	17-1/2	25	30	
Watts @ 35°F (1.7°C) Evaporator & 100°F (38°C) Ambient	15	25	40	50	
Watts @ 35°F (1.7°C) Evaporator & 100°F (38°C) Ambient	6221	9623	12250	16025	

* Allows continued operation with some restriction in the water strainer

** Air-cooled models only

***HACR type per NEC

ELECTRICAL CONNECTIONS

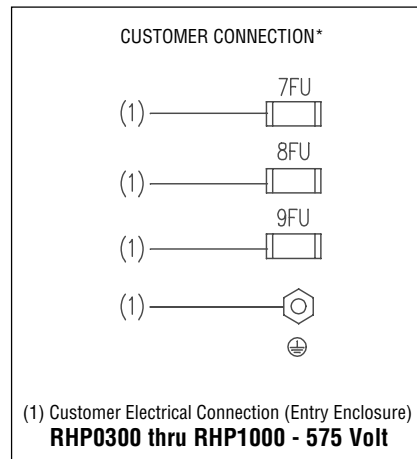
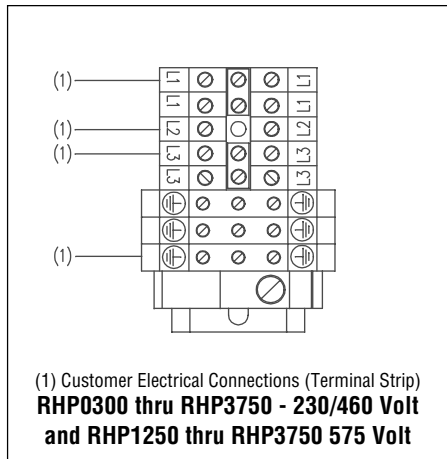

WIRING DIAGRAM

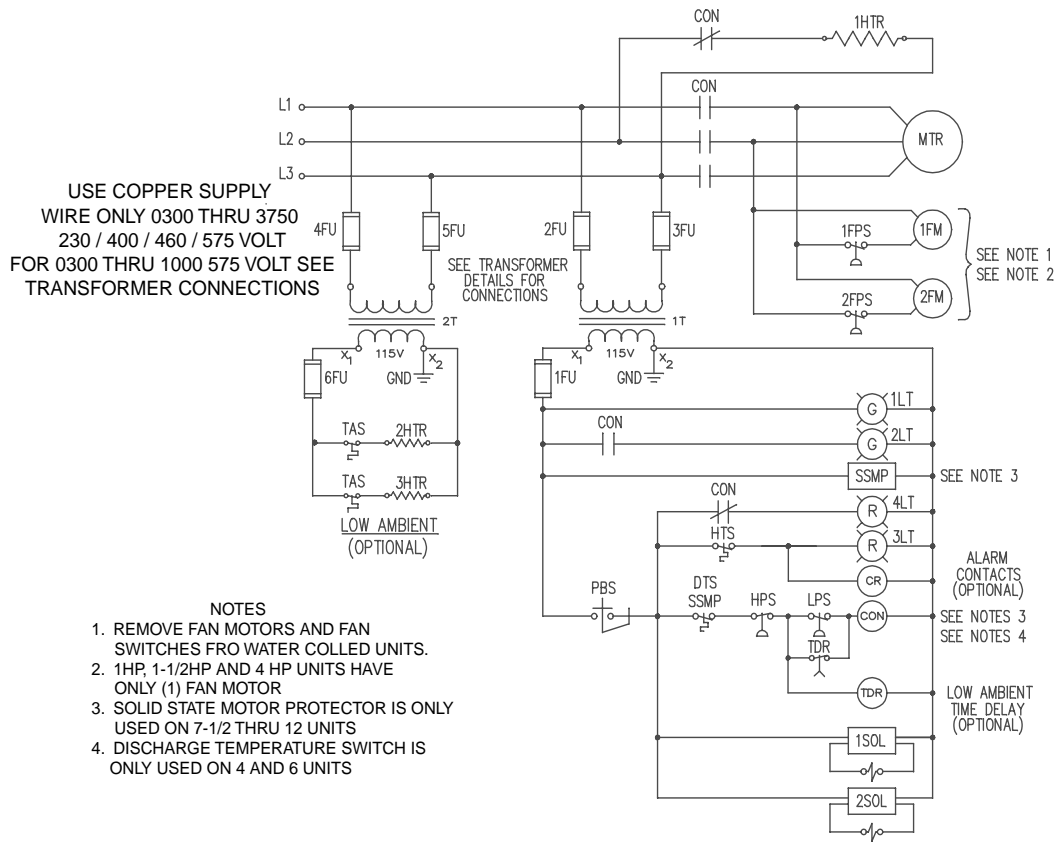

CONTROL TRANSFORMER CONNECTIONS

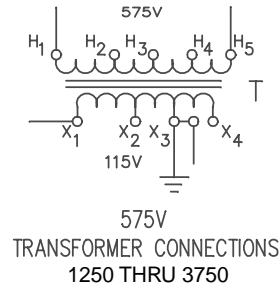
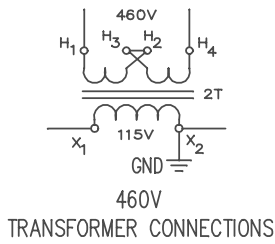
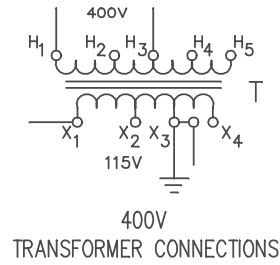
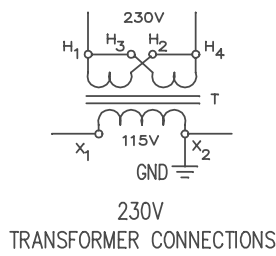

1 THRU 3 - 575 VOLT POWER TRANSFORMER CONNECTION

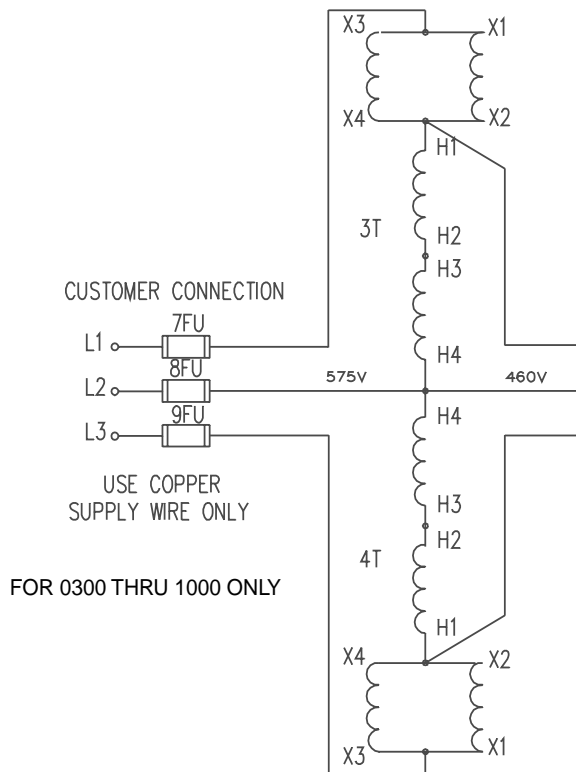

NOTES

2. FOR 1000 ONLY.

- 7FU - FUSE, LITTELFUSE, CCMR10, 600V (SEE NOTE 1)
- 8FU - FUSE, LITTELFUSE, CCMR10, 600V (SEE NOTE 1)
- 9FU - FUSE, LITTELFUSE, CCMR10, 600V (SEE NOTE 1)
- 7FU - FUSE, LITTELFUSE, CCMR15, 600V (SEE NOTE 2)
- 8FU - FUSE, LITTELFUSE, CCMR15, 600V (SEE NOTE 2)
- 9FU - FUSE, LITTELFUSE, CCMR15, 600V (SEE NOTE 2)

DIMENSIONS AND WEIGHTS

DIMENSIONS IN INCHES (DIMENSIONS IN MILLIMETERS)				
MODEL	0300 0500	0750 1000 1250	1750	2000 3000 3750
A	43" (1092)	43" (1092)	50" (1270)	60" (1524)
B	38" (965)	38" (965)	48" (1219)	48" (1219)
C	32" (813)	44" (1118)	50" (1270)	50" (1270)
D	NA	NA	54" (1371.6)	64" (1625.6)
E	2-3/8" (60)	2-3/8" (60)	6" (152.4)	6" (152.4)
F	24-1/4" (617)	24-1/4" (617)	5" (127)	5" (127)
G	1" NPT	1-1/2" NPT	3" NPT	3" NPT
H	31-1/4" (794)	31-1/4" (794)	40" (1016)	40" (1016)
J	35-3/8" (899)	35-3/8" (899)	45" (1143)	45" (1143)
K	27-7/8" (708)	39-7/8" (1013)	46" (1168.4)	46" (1168.4)
L	5/8" (16)	5/8" (16)	5/8" (16)	5/8" (16)
M	2-1/2" (63.5)	2-1/2" (63.5)	2-1/2" (63.5)	2-1/2" (63.5)
N	10-3/4" (273)	10-3/4" (273)	10" (254)	10" (254)
P	16-3/4" (426)	16-3/4" (426)	17-1/2" (444.5)	17-1/2" (444.5)
Q	2-1/2" (63.5)	2-1/2" (63.5)	2-1/2" (63.5)	2-1/2" (63.5)
R	7" (178)	7" (178)	4-7/8" (123.8)	4-7/8" (123.8)
S	9" (229)	9" (229)	6-7/8" (174.6)	6-7/8" (174.6)
T	1/2" NPT(F)	1/2" NPT(F)	3/4" NPT(F)	3/4" NPT(F)
U	19" (483)	19" (483)	11-7/8" (301.6)	11-7/8" (301.6)
WEIGHT	A/C	370 lbs (168kg) 380 lbs (172kg)	465 lbs (211kg) 480 lbs (218kg) 590 lbs (268kg)	1025 lbs (465kg) 1300 lbs (590kg) 1565 lbs (710kg) 1585 lbs (719kg)
	W/C	360 lbs (164kg) 370 lbs (168kg)	445 lbs (202kg) 460 lbs (209kg) 500 lbs (227kg)	925 lbs (420kg) 1000 lbs (454kg) 1265 lbs (574kg) 1285 lbs (583kg)

NOTE: DIMENSIONS AND WEIGHTS ARE FOR REFERENCE ONLY.
REQUEST CERTIFIED DRAWINGS FOR CONSTRUCTION PURPOSES.

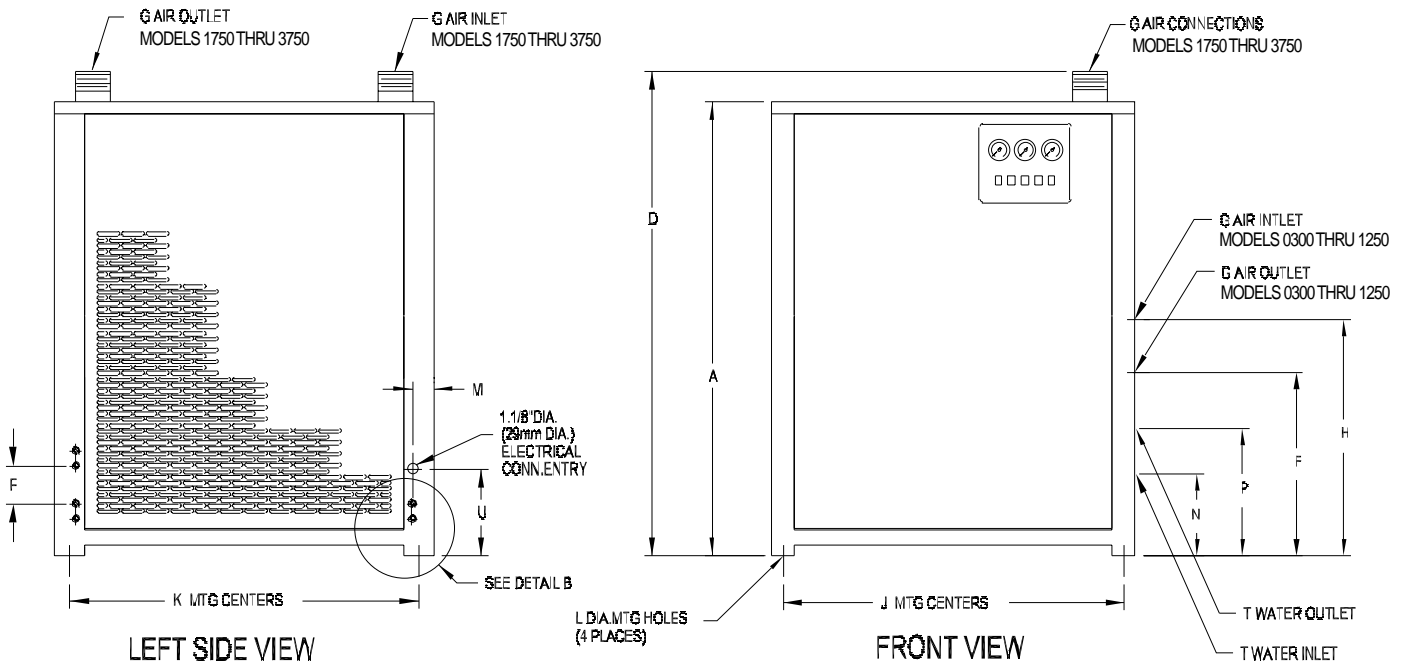
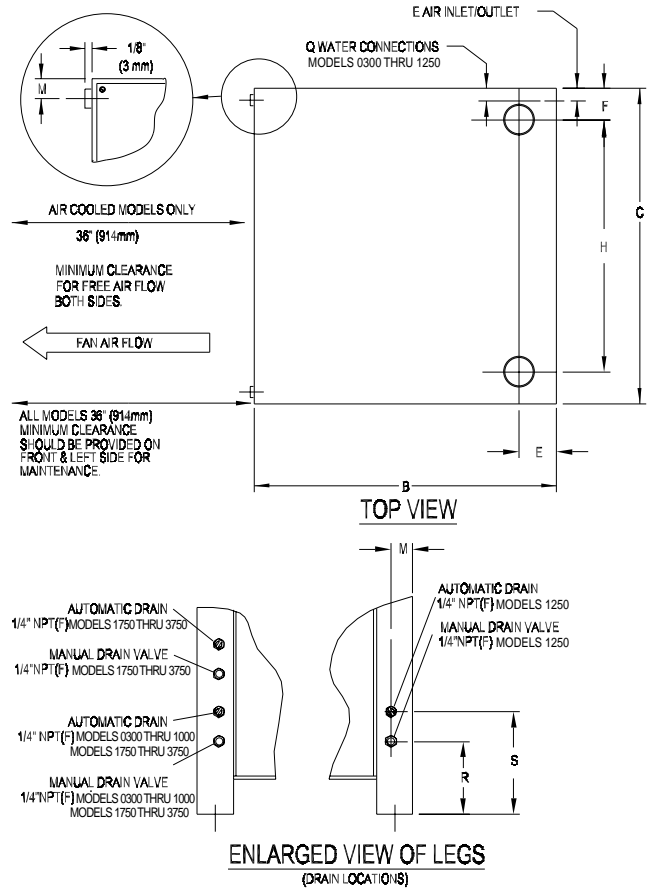

TROUBLESHOOTING GUIDE

SYMPTOM	POSSIBLE CAUSES	CORRECTIVE ACTION
A) Water downstream of dryer	<ol style="list-style-type: none"> 1. Residual free moisture remaining in downstream pipelines. 2. Air by-pass system is open. 3. Inlet and Outlet connections are reversed. 4. Temperatures surrounding air lines. downstream of dryer have dropped below dryers dew point rating. 5. Excessive free moisture (bulk liquid) at dryer inlet. 6. Condensate not being automatically drained. Drain mechanism is clogged or inoperative. Drain line is restricted or frozen. Electric drain timer not set to allow for sufficient condensate removal. 7. Dryer overloaded resulting in elevated dew point. 8. Refrigeration system not functioning properly resulting in elevated dew point. 9. Separator element not properly installed. 	<p>Blow out system with dry air.</p> <p>Check valve positions. Check for correct connection. Insulate or heat trace air lines exposed to low ambients or dry air to lower dew point. Install separator ahead of dryer. Rebuild drain mechanism if inoperative. Open drain line. Reset time so that all liquid is discharged. Check inlet air temperature and pressure, flow rate (compressor capacity) and ambient air or water temperature.</p> <p>See D below.</p> <p>Check element installation.</p>
B) High pressure drop across dryer	<ol style="list-style-type: none"> 1. Excessive air flow. 2. Freezing of moisture in evaporator because of refrigeration system improperly functioning. 3. Inlet air strainer clogged. 4. Separator filter clogged. 	<p>Check flow rate. See D below.</p> <p>Clean inlet air strainer. Replace filter cartridge.</p>
C) High Temperature Alarm	<ol style="list-style-type: none"> 1. Dryer overloaded resulting in high air outlet temperature. 2. Refrigeration system not functioning properly resulting in high air outlet temperature. 3. Unit functioning normally but thermostatic switch is malfunctioning or not securely mounted. 	<p>See A 7.</p> <p>See D below.</p> <p>Contact qualified refrigeration repairman or manufacturer's service department. Check power to unit.</p>
D) Refrigeration system not functioning properly <ol style="list-style-type: none"> 1. Power on light off. 2. Refrigerant Suction Pressure above set point. 3. Refrigerant Suction Pressure Gauge below set point. 4. Refrigerant system cut out light on (with on/off switch in on position). 	<ol style="list-style-type: none"> a. Power failure. b. Line disconnect switch open. c. Blown fuses, open breaker. d. Faulty wiring, loose terminals. <ol style="list-style-type: none"> a. Refrigeration compressor not running. b. High inlet air temperature. c. High ambient air temperature. d. Hot gas by-pass valve improperly set. <ol style="list-style-type: none"> a. Hot gas by-pass valve improperly set. b. Low on refrigerant. <ol style="list-style-type: none"> a. High or low ambient temperature. b. Air-cooled models - Dirty, clogged condenser fins, obstructed air flow across condenser, or non-functioning fan motor or fan control switch. c. Water-cooled models - Cooling water temperature too high, or flow too low, faulty water regulating valve, clogged water strainer. d. Start-up - high pressure switch may have tripped. e. High discharge temperature (Models 4 thru 6) f. Solid state motor protector (Models 7.5 thru 12) 	<p>Close disconnect switch. Check for continuity. Have electrician check electrical connections.</p> <p>Contact qualified refrigeration repairman or manufacturer's service department. Check temperature. Check temperature. Contact qualified refrigeration repairman or manufacturer's service department. Contact qualified refrigeration repairman or manufacturer's service department.</p> <p>Check ambient temperature range. Clean condenser and check for free air flow, if problem persists contact qualified refrigeration repairman or manufacturer's service department. Clean strainer, check water flow and temperature, if problem persists contact qualified refrigeration repairman or manufacturer's service department. Manually reset and restart without load. Contact qualified refrigeration repairman or manufacturer's service department. Improper phase connection to dryer. Reverse two power leads. Contact qualified refrigeration repairman or manufacturer's service department.</p>

PARTS LIST

Voltage	208-230/3/60	400/3/50 460/3/60	575/3/60	208-230/3/60	400/3/50* 460/3/60	575/3/60	208-230/3/60	400/3/50* 460/3/60	575/3/60
Parts Description	0300	0300	0300	0500	0500	0500	0750	0750	0750
ELECTRICAL SYSTEM									
Power Transformer	---	---	G6120-276-9	---	---	G6120-276-9	---	---	G6120-276-9
Fuse, Power Transformer	---	---	G5920-274-33	---	---	G5920-274-33	---	---	G5920-274-33
Control Circuit Transformer	G6120-092-1	G6120-092-1	G6120-092-1	G6120-092-1	G6120-092-1	G6120-092-1	G6120-092-1	G6120-092-1	G6120-092-1
Fuse, Control Circuit	G5920-274-20	G5920-274-20	G5920-274-20	G5920-274-20	G5920-274-20	G5920-274-20	G5920-274-20	G5920-274-20	G5920-274-20
Fuse, Primary, Transformer	G5920-274-19	G5920-274-19	G5920-274-19	G5920-274-19	G5920-274-19	G5920-274-19	G5920-274-19	G5920-274-19	G5920-274-19
On/Off Switch	G6110-706-13	G6110-706-13	G6110-706-13	G6110-706-13	G6110-706-13	G6110-706-13	G6110-706-13	G6110-706-13	G6110-706-13
Light - Red	G6350-457-27	G6350-457-27	G6350-457-27	G6350-457-27	G6350-457-27	G6350-457-27	G6350-457-27	G6350-457-27	G6350-457-27
Light - Green	G6350-457-25	G6350-457-25	G6350-457-25	G6350-457-25	G6350-457-25	G6350-457-25	G6350-457-25	G6350-457-25	G6350-457-25
High Temperature Light Sensor	G5930-189-1	G5930-189-1	G5930-189-1	G5930-189-1	G5930-189-1	G5930-189-1	G5930-189-1	G5930-189-1	G5930-189-1
Discharge Temperature Switch	---	---	---	---	---	---	---	---	---
Solid State Motor Protector	---	---	---	---	---	---	---	---	---
High Refrigerant Pressure Switch (Air-cooled)	G4130-138-32	G4130-138-32	G4130-138-32	G4130-138-32	G4130-138-32	G4130-138-32	G4130-138-32	G4130-138-32	G4130-138-32
High Refrigerant Pressure Switch (Water-cooled)	G4130-139-34	G4130-139-34	G4130-139-34	G4130-139-34	G4130-139-34	G4130-139-34	G4130-139-34	G4130-139-34	G4130-139-34
Low Refrigerant Pressure Switch	G4130-138-22	G4130-138-22	G4130-138-22	G4130-138-22	G4130-138-22	G4130-138-22	G4130-138-22	G4130-138-22	G4130-138-22
Contactors	G5910-135-4	G5910-135-4	G5910-135-4	G5910-135-19	G5910-135-4	G5910-135-4	G5910-135-19	G5910-135-4	G5910-135-4
Aux Contactor NO	G6110-101-13	G6110-101-13	G6110-101-13	G6110-101-13	G6110-101-13	G6110-101-13	G6110-101-13	G6110-101-13	G6110-101-13
Aux Contactor NC	G6110-101-14	G6110-101-14	G6110-101-14	G6110-101-14	G6110-101-14	G6110-101-14	G6110-101-14	G6110-101-14	G6110-101-14
Aux Contactor NCNO	---	---	---	---	---	---	---	---	---
Fan Cut-out Switch (Fan 1)	G4130-138-23	G4130-138-23	G4130-138-23	G4130-138-23	G4130-138-23	G4130-138-23	G4130-138-30	G4130-138-30	G4130-138-30
Fan Cut-out Switch (Fan 2)	---	---	---	---	---	---	G4130-138-24	G4130-138-24	G4130-138-24
REFRIGERATION SYSTEM									
Condensing unit (Air-cooled)	G4130-127-16	G4130-127-17	G4130-127-17	G4130-127-19	G4130-127-20	G4130-127-20	G4130-125-14	G4130-125-15	G4130-125-15
Compressor	G4130-108-53	G4130-108-54	G4130-108-54	G4130-108-55	G4130-108-56	G4130-108-56	G4130-108-57	G4130-108-58	G4130-108-58
Crankcase Heater	G5920-327-12	G5920-327-13	G5920-327-13	G5920-327-12	G5920-327-13	G5920-327-13	G5920-327-12	G5920-327-13	G5920-327-13
Hot Gas By-pass Valve	G4130-690-5	G4130-690-5	G4130-690-5	G4130-690-5	G4130-690-5	G4130-690-5	G4130-690-5	G4130-690-5	G4130-690-5
Condenser (Air-cooled)	G4130-111-23	G4130-111-23	G4130-111-23	G4130-111-24	G4130-111-24	G4130-111-24	G4130-111-25	G4130-111-25	G4130-111-25
Condenser (Water-cooled)	G4130-112-3	G4130-112-3	G4130-112-3	G4130-111-8	G4130-111-8	G4130-111-8	G4130-115-13	G4130-115-13	G4130-115-13
Fan Motor	G6105-238-37	G6105-238-38	G6105-238-38	G6105-238-39	G6105-238-40	G6105-238-40	G6105-238-39	G6105-238-40	G6105-238-40
Fan Blade	G4140-227-22	G4140-227-22	G4140-227-22	G4140-227-23	G4140-227-23	G4140-227-23	G4140-227-24	G4140-227-24	G4140-227-24
Filter Dryer (liquid line)	G4130-166-2	G4130-166-2	G4130-166-2	G4130-166-2	G4130-166-2	G4130-166-2	G4130-166-2	G4130-166-2	G4130-166-2
Sight Glass	G4130-725-3	G4130-725-3	G4130-725-3	G4130-725-3	G4130-725-3	G4130-725-3	G4130-725-3	G4130-725-3	G4130-725-3
Thermal Expansion Valve	G4130-829-21	G4130-829-21	G4130-829-21	G4130-829-21	G4130-829-21	G4130-829-21	G4130-829-28	G4130-829-28	G4130-829-28
De-Superheating Valve	---	---	---	---	---	---	---	---	---
Suction Filter	---	---	---	---	---	---	---	---	---
Suction Pressure Gauge	G6685-287-3	G6685-287-3	G6685-287-3	G6685-287-3	G6685-287-3	G6685-287-3	G6685-287-3	G6685-287-3	G6685-287-3
WATER SYSTEM (WATER-COOLED ONLY)									
Cooling Water Strainer	G4731-735-1	G4731-735-1	G4731-735-1	G4731-735-1	G4731-735-1	G4731-735-1	G4731-735-1	G4731-735-1	G4731-735-1
Cooling Water Strainer Screen	G4731-735-5	G4731-735-5	G4731-735-5	G4731-735-5	G4731-735-5	G4731-735-5	G4731-735-5	G4731-735-5	G4731-735-5
Cooling Water Regulating Valve	G4130-145-1	G4130-145-1	G4130-145-1	G4130-145-1	G4130-145-1	G4130-145-1	G4130-145-1	G4130-145-1	G4130-145-1
AIR SYSTEM									
Inlet Air Strainer	G4731-736-8	G4731-736-8	G4731-736-8	G4731-736-8	G4731-736-8	G4731-736-8	G4731-736-9	G4731-736-9	G4731-736-9
Replacement, Screen Strainer	G4730-735-12	G4730-735-12	G4730-735-12	G4730-735-12	G4730-735-12	G4730-735-12	G4731-735-13	G4731-735-13	G4731-735-13
Separator Filter/Cartridge	GE9-24-09	GE9-24-09	GE9-24-09	GE9-24-09	GE9-24-09	GE9-24-09	GE9-32-11	GE9-32-11	GE9-32-11
Sleeve Only	GS9-24	GS9-24	GS9-24	GS9-24	GS9-24	GS9-24	GS9-32	GS9-32	GS9-32
Air Pressure Gauge	G6685-270-5	G6685-270-5	G6685-270-5	G6685-270-5	G6685-270-5	G6685-270-5	G6685-270-5	G6685-270-5	G6685-270-5
Air Temperature Gauge	G6685-281-6	G6685-281-6	G6685-281-6	G6685-281-6	G6685-281-6	G6685-281-6	G6685-281-6	G6685-281-6	G6685-281-6
ELECTRIC DRAIN									
Timer	G5945-693-4	G5945-693-4	G5945-693-4	G5945-693-4	G5945-693-4	G5945-693-4	G5945-693-4	G5945-693-4	G5945-693-4
Coil and Valve	G4810-747-4	G4810-747-4	G4810-747-4	G4810-747-4	G4810-747-4	G4810-747-4	G4810-747-4	G4810-747-4	G4810-747-4

(*) For 400/3/50 use control transformer G6120-093-6

PARTS LIST

Voltage	208-230/3/60	400/3/50 460/3/60	575/3/60	208-230/3/60	400/3/50* 460/3/60	575/3/50	208-230/3/60	400/3/50* 460/3/60	575/3/60
Parts Description	1000	1000	1000	1250	1250	1250	1750	1750	1750
ELECTRICAL SYSTEM									
Power Transformer	---	---	G6120-277-1	---	---	---	---	---	---
Fuse, Power Transformer	---	---	G5920-274-34	---	---	---	---	---	---
Control Circuit Transformer	G6120-092-1	G6120-092-1	G6120-092-1	G6120-092-1	G6120-092-1	G6120-093-6	G6120-092-1	G6120-092-1	G6120-093-6
Fuse, Control Circuit	G5920-274-20	G5920-274-20	G5920-274-20	G5920-274-20	G5920-274-20	G5920-274-20	G5920-274-20	G5920-274-20	G5920-274-20
Fuse, Primary, Transformer	G5920-274-19	G5920-274-19	G5920-274-19	G5920-274-19	G5920-274-19	G5920-274-19	G5920-274-19	G5920-274-19	G5920-274-19
On/Off Switch	G6110-706-13	G6110-706-13	G6110-706-13	G6110-706-13	G6110-706-13	G6110-706-13	G6110-706-13	G6110-706-13	G6110-706-13
Light - Red	G6350-457-27	G6350-457-27	G6350-457-27	G6350-457-27	G6350-457-27	G6350-457-27	G6350-457-27	G6350-457-27	G6350-457-27
Light - Green	G6350-457-25	G6350-457-25	G6350-457-25	G6350-457-25	G6350-457-25	G6350-457-25	G6350-457-25	G6350-457-25	G6350-457-25
High Temperature Light Sensor	G5930-189-1	G5930-189-1	G5930-189-1	G5930-189-1	G5930-189-1	G5930-189-1	G5930-189-1	G5930-189-1	G5930-189-1
Discharge Temperature Switch	---	---	---	G5930-190-8	G5930-190-8	G5930-190-8	G5930-190-8	G5930-190-8	G5930-190-8
Solid State Motor Protector	---	---	---	---	---	---	---	---	---
High Refrigerant Pressure Switch (Air-cooled)	G4130-138-32	G4130-138-32	G4130-138-32	G4130-138-33	G4130-138-33	G4130-138-33	G4130-138-33	G4130-138-33G	G4130-138-33
High Refrigerant Pressure Switch (Water-cooled)	G4130-139-34	G4130-139-34	G4130-139-34	G4130-139-35	G4130-139-35	G4130-139-35	G4130-139-35	G4130-139-35	G4130-139-35
Low Refrigerant Pressure Switch	G4130-138-22	G4130-138-22	G4130-138-22	G4130-138-29	G4130-138-29	G4130-138-29	G4130-138-29	G4130-138-29	G4130-138-29
Contacto5910-135-4	G5910-135-19	G5910-135-4	G5910-135-4	G5910-135-19	G5910-135-4	G5910-135-4	G5910-135-10	G5910-135-4	G5910-135-4
Aux Contactor NO	G6110-101-13	G6110-101-13	G6110-101-13	G6110-101-13	G6110-101-13	G6110-101-13	G6110-101-13	G6110-101-13	G6110-101-13
Aux Contactor NC	G6110-101-14	G6110-101-14	G6110-101-14	G6110-101-14	G6110-101-14	G6110-101-14	G6110-101-14	G6110-101-14	G6110-101-14
Aux Contactor NC/NO	---	---	---	---	---	---	---	---	---
Fan Cut-out Switch (Fan 1)	G4130-138-30	G4130-138-30	G4130-138-30	G4130-138-26	G4130-138-26	G4130-138-26	G4130-138-26	G4130-138-26	G4130-138-26
Fan Cut-out Switch (Fan 2)	G4130-138-24	G4130-138-24	G4130-138-24	---	---	---	G4130-138-27	G4130-138-27	G4130-138-27
REFRIGERATION SYSTEM									
Condensing unit (Air-cooled)	G4130-129-1	G4130-129-2	G4130-129-2	G4130-129-3	G4130-129-4	G4130-129-5	G4130-129-6	G4130-129-7	G4130-129-8
Compressor	G4130-108-64	G4130-108-65	G4130-108-65	G4130-106-57	G4130-106-48	G4130-106-58	G4130-106-59	G4130-106-49	G4130-106-60
Crankcase Heater	G5920-327-12	G5920-327-13	G5920-327-13	G5920-330-18	G5920-330-16	G5920-330-19	G5920-330-18	G5920-330-16	G5920-330-19
Hot Gas By-pass Valve	G4130-690-5	G4130-690-5	G4130-690-5	G4130-690-18	G4130-690-18	G4130-690-18	G4130-690-18	G4130-690-18	G4130-690-18
Condenser (Air-cooled)	G4130-111-28	G4130-111-28	G4130-111-28	G4130-113-11	G4130-113-11	G4130-113-11	G4130-112-12	G4130-112-12	G4130-112-12
Condenser (Water-cooled)	G4130-115-13	G4130-115-13	G4130-115-13	G4130-115-11	G4130-115-11	G4130-115-11	G4130-115-11	G4130-115-11	G4130-115-11
Fan Motor	G6105-238-39	G6105-238-40	G6105-238-40	G6105-238-46	G6105-238-23	G6105-238-47	G6105-238-48	G6105-238-52	G6105-238-49
Fan Blade	G4140-227-24	G4140-227-24	G4140-227-24	G4140-227-14	G4140-227-14	G4140-227-14	G4140-228-10	G4140-228-10	G4140-228-10
Filter Dryer (liquid line)	G4130-166-2	G4130-166-2	G4130-166-2	G4130-166-4	G4130-166-4	G4130-166-4	G4130-166-4	G4130-166-4	G4130-166-4
Sight Glass	G4130-725-3	G4130-725-3	G4130-725-3	G4130-725-3	G4130-725-3	G4130-725-3	G4130-725-4	G4130-725-4	G4130-725-4
Thermal Expansion Valve	G4130-829-14	G4130-829-14	G4130-829-14	G4130-829-23	G4130-829-23	G4130-829-23	G4130-829-38	G4130-829-38	G4130-829-38
De-Superheating Valve	---	---	---	---	---	---	---	---	---
Suction Filter	---	---	---	---	---	---	---	---	---
Suction Pressure Gauge	G6685-287-3	G6685-287-3	G6685-287-3	G6685-287-3	G6685-287-3	G6685-287-3	G6685-287-3	G6685-287-3	G6685-287-3
WATER SYSTEM (WATER-COOLED ONLY)									
Cooling Water Strainer	G4731-735-1	G4731-735-1	G4731-735-1	G4731-735-2	G4731-735-2	G4731-735-2	G4731-735-2	G4731-735-2	G4731-735-2
Cooling Water Strainer Screen	G4731-735-5	G4731-735-5	G4731-735-5	G4731-735-7	G4731-735-7	G4731-735-7	G4731-735-7	G4731-735-7	G4731-735-7
Cooling Water Regulating Valve	G4130-145-1	G4130-145-1	G4130-145-1	G4130-145-3	G4130-145-3	G4130-145-3	G4130-145-3	G4130-145-3	G4130-145-3
AIR SYSTEM									
Inlet Air Strainer	G4731-736-9	G4731-736-9	G4731-736-9	G4731-736-9	G4731-736-9	G4731-736-9	G4731-736-10	G4731-736-10	G4731-736-10
Replacement, Screen Strainer	G4730-735-13	G4730-735-13	G4730-735-13	G4730-735-13	G4730-735-13	G4730-735-13	G4731-735-14	G4731-735-14	G4731-735-14
Separator Filter/Cartridge	GE9-32-11	GE9-32-11	GE9-32-11	GE9-32-11	GE9-32-11	GE9-32-11	GE9-32-11 (2)	GE9-32-11 (2)	GE9-32-11(2)
Sleeve Only	GS9-32	GS9-32	GS9-32	GS9-32	GS9-32	GS9-32	GS9-32 (2)	GS9-32 (2)	GS9-32 (2)
Air Pressure Gauge	G6685-270-5	G6685-270-5	G6685-270-5	G6685-270-5	G6685-270-5	G6685-270-5	G6685-270-5	G6685-270-5	G6685-270-5
Air Temperature Gauge	G6685-281-6	G6685-281-6	G6685-281-6	G6685-281-6	G6685-281-6	G6685-281-6	G6685-281-6	G6685-281-6	G6685-281-6
ELECTRIC DRAIN									
Timer	G5945-693-4	G5945-693-4	G5945-693-4	G5945-693-4	G5945-693-4	G5945-693-4	G5945-693-4	G5945-693-4	G5945-693-4
Coil and Valve	G4810-747-4	G4810-747-4	G4810-747-4	G4810-747-4	G4810-747-4	G4810-747-4	G4810-747-4	G4810-747-4	G4810-747-4

(*) For 400/3/50 use control transformer G6120-093-6

PARTS LIST

Voltage	208-230/3/60	400/3/50 460/3/60	575/3/60	208-230/3/60	400/3/50* 460/3/60	575/3/60	208-230/3/60	400/3/50* 460/3/60	575/3/60
Parts Description	2000	2000	2000	3000	3000	3000	3750	3750	3750
ELECTRICAL SYSTEM									
Power Transformer	---	---	---	---	---	---	---	---	---
Fuse, Power Transformer	---	---	---	---	---	---	---	---	---
Control Circuit Transformer	G6120-092-3	G6120-092-3	G6120-095-2	G6120-092-3	G6120-092-3	G6120-095-2	G6120-092-3	G6120-092-3	G6120-095-2
Fuse, Control Circuit	G5920-274-25	G5920-274-25	G5920-274-25	G5920-274-25	G5920-274-25	G5920-274-25	G5920-274-25	G5920-274-25	G5920-274-25
Fuse, Primary Transformer	G5920-274-19	G5920-274-19	G5920-274-19	G5920-274-19	G5920-274-19	G5920-274-19	G5920-274-19	G5920-274-19	G5920-274-19
On/Off Switch	G6110-706-13	G6110-706-13	G6110-706-13	G6110-706-13	G6110-706-13	G6110-706-13	G6110-706-13	G6110-706-13	G6110-706-13
Light - Red	G6350-457-27	G6350-457-27	G6350-457-27	G6350-457-27	G6350-457-27	G6350-457-27	G6350-457-27	G6350-457-27	G6350-457-27
Light - Green	G6350-457-25	G6350-457-25	G6350-457-25	G6350-457-25	G6350-457-25	G6350-457-25	G6350-457-25	G6350-457-25	G6350-457-25
High Temperature Light Sensor	G5930-189-1	G5930-189-1	G5930-189-1	G5930-189-1	G5930-189-1	G5930-189-1	G5930-189-1	G5930-189-1	G5930-189-1
Discharge Temperature Switch	---	---	---	---	---	---	---	---	---
Solid State Motor Protector	G5935-580-7	G5935-580-7	G5935-580-7	G5935-580-7	G5935-580-7	G5935-580-7	G5935-580-7	G5935-580-7	G5935-580-7
High Refrigerant Pressure Switch (Air-cooled)	G4130-138-33	G4130-138-33	G4130-138-33	G4130-138-33	G4130-138-33	G4130-138-33	G4130-138-33	G4130-138-33	G4130-138-33
High Refrigerant Pressure Switch (Water-cooled)	G4130-139-35	G4130-139-35	G4130-139-35	G4130-139-35	G4130-139-35	G4130-139-35	G4130-139-35	G4130-139-35	G4130-139-35
Low Refrigerant Pressure Switch	G4130-138-29	G4130-138-29	G4130-138-29	G4130-138-29	G4130-138-29	G4130-138-29	G4130-138-29	G4130-138-29	G4130-138-29
Contactors	G5910-135-12	G5910-135-19	G5910-135-19	G5910-135-16	G5910-135-19	G5910-135-19	G5910-135-16	G5910-135-19	G5910-135-19
Aux Contactor NO	---	---	---	---	---	---	---	---	---
Aux Contactor NC	---	---	---	---	---	---	---	---	---
Aux Contactor NC/NO	G6110-101-20	G6110-101-20	G6110-101-20	G6110-101-20	G6110-101-20	G6110-101-20	G6110-101-20	G6110-101-20	G6110-101-20
Fan Cut-out Switch (Fan 1)	G4130-138-26	G4130-138-26	G4130-138-26	G4130-138-26	G4130-138-26	G4130-138-26	G4130-138-26	G4130-138-26	G4130-138-26
Fan Cut-out Switch (Fan 2)	G4130-138-27	G4130-138-27	G4130-138-27	G4130-138-27	G4130-138-27	G4130-138-27	G4130-138-27	G4130-138-27	G4130-138-27
REFRIGERATION SYSTEM									
Condensing unit (Air-cooled)	G4130-129-9	G4130-129-10	G4130-129-11	G4130-129-12	G4130-129-13	G4130-129-14	G4130-129-15	G4130-129-16	G4130-129-17
Compressor	G4130-106-61	G4130-106-50	G4130-106-62	G4130-106-63	G4130-106-51	G4130-106-64	G4130-106-65	G4130-106-52	G4130-106-66
Crankcase Heater	G5920-330-20	G5920-330-17	G5920-330-21	G5920-330-20	G5920-330-17	G5920-330-21	G5920-330-20	G5920-330-17	G5920-330-21
Hot Gas By-pass Valve	G4130-690-19	G4130-690-19	G4130-690-19	G4130-690-19	G4130-690-19	G4130-690-19	G4130-690-19	G4130-690-19	G4130-690-19
Condenser (Air-cooled)	G4130-111-15	G4130-111-15	G4130-111-15	G4130-111-15	G4130-111-15	G4130-111-15	G4130-111-15	G4130-111-15	G4130-111-15
Condenser (Water-cooled)	G4130-115-12	G4130-115-12	G4130-115-12	G4130-115-12	G4130-115-12	G4130-115-12	G4130-115-12	G4130-115-12	G4130-115-12
Fan Motor	G6105-238-50	G6105-238-25	G6105-238-51	G6105-238-50	G6105-238-25	G6105-238-51	G6105-238-50	G6105-238-25	G6105-238-51
Fan Blade	G4140-227-15	G4140-227-15	G4140-227-15	G4140-227-15	G4140-227-15	G4140-227-15	G4140-227-15	G4140-227-15	G4140-227-15
Filter Dryer (liquid line)	G4130-166-4	G4130-166-4	G4130-166-4	G4130-166-4	G4130-166-4	G4130-166-4	G4130-166-4	G4130-166-4	G4130-166-4
Sight Glass	G4130-725-4	G4130-725-4	G4130-725-4	G4130-725-4	G4130-725-4	G4130-725-4	G4130-725-4	G4130-725-4	G4130-725-4
Thermal Expansion Valve	G4130-829-38	G4130-829-38	G4130-829-38	G4130-829-35	G4130-829-35	G4130-829-35	G4130-829-35	G4130-829-35	G4130-829-35
De-Superheating Valve	G4130-829-19	G4130-829-19	G4130-829-19	G4130-829-20	G4130-829-20	G4130-829-20	G4130-829-20	G4130-829-20	G4130-829-20
Suction Filter	G4130-246-1	G4130-246-1	G4130-246-1	G4130-246-1	G4130-246-1	G4130-246-1	G4130-246-1	G4130-246-1	G4130-246-1
Suction Pressure Gauge	G6685-287-3	G6685-287-3	G6685-287-3	G6685-287-3	G6685-287-3	G6685-287-3	G6685-287-3	G6685-287-3	G6685-287-3
WATER SYSTEM (WATER-COOLED ONLY)									
Cooling Water Strainer	G4731-735-2	G4731-735-2	G4731-735-2	G4731-735-3	G4731-735-3	G4731-735-3	G4731-735-4	G4731-735-4	G4731-735-4
Cooling Water Strainer Screen	G4731-735-7	G4731-735-7	G4731-735-7	G4731-735-8	G4731-735-8	G4731-735-8	G4731-735-9	G4731-735-9	G4731-735-9
Cooling Water Regulating Valve	G4130-145-3	G4130-145-3	G4130-145-3	G4130-145-5	G4130-145-5	G4130-145-5	G4130-145-6	G4130-145-6	G4130-145-6
AIR SYSTEM									
Inlet Air Strainer	G4731-736-10	G4731-736-10	G4731-736-10	G4731-736-10	G4731-736-10	G4731-736-10	G4731-736-10	G4731-736-10	G4731-736-10
Replacement, Screen Strainer	G4731-735-14	G4731-735-14	G4731-735-14	G4731-735-14	G4731-735-14	G4731-735-14	G4731-735-14	G4731-735-14	G4731-735-14
Separator Filter/Cartridge	GE9-32-11 (2)	GE9-32-11 (2)	GE9-32-11 (2)	GE9-32-11 (3)	GE9-32-11 (3)	GE9-32-11 (3)	GE9-32-11 (3)	GE9-32-11 (3)	GE9-32-11 (3)
Sleeve Only	GS9-32 (2)	GS9-32 (2)	GS9-32 (2)	GS9-32 (3)	GS9-32 (3)	GS9-32 (3)	GS9-32 (3)	GS9-32 (3)	GS9-32 (3)
Air Pressure Gauge	G6685-270-5	G6685-270-5	G6685-270-5	G6685-270-5	G6685-270-5	G6685-270-5	G6685-270-5	G6685-270-5	G6685-270-5
Air Temperature Gauge	G6685-281-6	G6685-281-6	G6685-281-6	G6685-281-6	G6685-281-6	G6685-281-6	G6685-281-6	G6685-281-6	G6685-281-6
ELECTRIC DRAIN									
Timer	G5945-693-4	G5945-693-4	G5945-693-4	G5945-693-4	G5945-693-4	G5945-693-4	G5945-693-4	G5945-693-4	G5945-693-4
Coil and Valve	G4810-747-4	G4810-747-4	G4810-747-4	G4810-747-4	G4810-747-4	G4810-747-4	G4810-747-4	G4810-747-4	G4810-747-4

(*) For 400/3/50 use control transformer G6120-95-2

WARRANTY

The manufacturer warrants the product manufactured by it, when properly installed, operated, applied, and maintained in accordance with procedures and recommendations outlined in manufacturer's instruction manuals, to be free from defects in material and workmanship for a period of one (1) year from the date of shipment to the buyer by the manufacturer or manufacturer's authorized distributor, or eighteen months from the date of shipment from the factory, whichever occurs first (refrigerated dryers, models 300 through 3750 scfm inclusive, for a period of two years from the date of shipment from the factory), provided such defect is discovered and brought to the manufacturer's attention within the aforesaid warranty period.

The manufacturer will repair or replace any product or part determined to be defective by the manufacturer within the warranty period, provided such defect occurred in normal service and not as a result of misuse, abuse, neglect or accident. Normal maintenance items requiring routine replacement are not warranted. For refrigerated dryers model 300 thru 3750 scfm, the manufacturer will include parts and labor for 18 months from the date of shipment from the factory and parts only for an additional six (6) months. On all other products, the warranty covers parts and labor for the warranty period. Repair or replacement shall be made at the factory or the installation site, at the sole option of the manufacturer. Any service performed on the product by anyone other than the manufacturer must first be authorized by the manufacturer.

Unauthorized service voids the warranty and any resulting charge or subsequent claim will not be paid.

Products repaired or replaced under warranty shall be warranted for the unexpired portion of the warranty applying to the original product.

The foregoing is the exclusive remedy of any buyer of the manufacturer's product. The maximum damages liability of the manufacturer is the original purchase price of the product or part.

THE FOREGOING WARRANTY IS EXCLUSIVE AND IN LIEU OF ALL OTHER WARRANTIES, WHETHER WRITTEN, ORAL, OR STATUTORY, AND IS EXPRESSED IN LIEU OF THE IMPLIED WARRANTY OF MERCHANTABILITY AND THE IMPLIED WARRANTY OF FITNESS FOR A PARTICULAR PURPOSE. THE MANUFACTURER SHALL NOT BE LIABLE FOR LOSS OR DAMAGE BY REASON OF STRICT LIABILITY IN TORT OR ITS NEGLIGENCE IN WHATEVER MANNER INCLUDING DESIGN, MANUFACTURE OR INSPECTION OF THE EQUIPMENT OR ITS FAILURE TO DISCOVER, REPORT, REPAIR, OR MODIFY LATENT DEFECTS INHERENT THEREIN.

THE MANUFACTURER, HIS REPRESENTATIVE OR DISTRIBUTOR SHALL NOT BE LIABLE FOR LOSS OF USE OF THE PRODUCT OR OTHER INCIDENTAL OR CONSEQUENTIAL COSTS, EXPENSES, OR DAMAGES INCURRED BY THE BUYER, WHETHER ARISING FROM BREACH OF WARRANTY, NEGLIGENCE OR STRICT LIABILITY IN TORT.

The manufacturer does not warrant any product, part, material, component, or accessory manufactured by others and sold or supplied in connection with the sale of manufacturer's products.

6/01

**AUTHORIZATION FROM THE SERVICE DEPARTMENT IS NECESSARY
BEFORE MATERIAL IS RETURNED TO THE FACTORY OR IN-WARRANTY REPAIRS ARE MADE.**



©2005 Gardner Denver, Inc.
<http://www.gardnerdenver.com>

respond@gardnerdenver.com

18-2-655 2nd edition 1/05

Litho in U.S.A.



For additional information contact
your local representative or
Gardner Denver Compressor and Pump Division,
1800 Gardner Expressway, Quincy, Illinois 62301
Customer Service Department Telephone:
(800) 682-9868 FAX: (217) 228-8243
Sales and Service in all major cities.
For parts information, contact Gardner Denver,
Master Distribution Center, Memphis, TN
Telephone: (800) 245-4946 FAX: (901) 542-6159