GARDNER DENVER®

13-9/10-643
6th Edition
March, 1997

ELECTRA-SCREW®
ELECTRA-SAVER®
ELECTRA-SAVER II®
STATIONARY BASE-MOUNTED
COMPRESSOR

AUTO SENTRY®-ES+ CONTROLS
AUTO SENTRY®-ES CONTROLS

DOMESTIC MODELS

EDM, EDP, EAQ & EBQ – 125 – 200 HP

INTERNATIONAL MODELS

EAQ – 75 – 112 KW (100 – 150 HP)

EBQ – 93 – 112 KW (125 – 150 HP)

OPERATING AND
SERVICE MANUAL

Gardner

Denver

MAINTAIN COMPRESSOR RELIABILITY AND PERFORMANCE WITH GENUINE GARDNER DENVER COMPRESSOR PARTS AND SUPPORT SERVICES

Gardner Denver Compressor genuine parts, engineered to original tolerances, are designed for optimum dependability — specifically for Gardner Denver compressor systems. Design and material innovations are the result of years of experience with hundreds of different compressor applications. Reliability in materials and quality assurance are incorporated in our genuine replacement parts.

Your authorized Gardner Denver Compressor distributor offers all the backup you'll need. A worldwide network of authorized distributors provides the finest product support in the air compressor industry. Your local authorized distributor maintains a large inventory of genuine parts and he is backed up for emergency parts by direct access to the Gardner Denver Machinery Inc. Master Distribution Center (MDC) in Memphis, Tennessee.

Your authorized distributor can support your Gardner

Denver air compressor with these services:

1. Trained parts specialists to assist you in selecting the correct replacement parts.
2. Factory warranted new and remanufactured rotary screw air ends. Most popular model remanufactured air ends are maintained in stock at MDC for purchase on an exchange basis with liberal core credit available for the replacement unit.
3. A full line of factory tested AEON™ compressor lubricants specifically formulated for use in Gardner Denver compressors.
4. Repair and maintenance kits designed with the necessary parts to simplify servicing your compressor.

Authorized distributor service technicians are factory-trained and skilled in compressor maintenance and repair. They are ready to respond and assist you by providing fast, expert maintenance and repair services.

For the location of your local authorized Gardner Denver Air Compressor distributor refer to the yellow pages of your phone directory or contact:

Distribution Center:
Gardner Denver Machinery Inc.
Master Distribution Center
5585 East Shelby Drive
Memphis, TN 38141
Phone: (901) 542-6100
(800) 245-4946
Fax: (901) 542-6159

Factory:
Gardner Denver Machinery Inc.
1800 Gardner Expressway
Quincy, IL 62301
Phone: (217) 222-5400
Fax: (217) 224-7814

REMANUFACTURED AIR ENDS

Whenever an air end requires replacement or repair, Gardner Denver offers an industry unique, factory remanufactured air end exchange program. From its modern Remanufacturing Center in Indianapolis, IN, Gardner Denver is committed to supplying you with the highest quality, factory remanufactured air ends that are guaranteed to save you time, aggravation and money.

Immediately Available

Repair downtime costs you money, which is why there are over 200 remanufactured units in inventory at all times, ready for immediate delivery.

Skilled Craftsmen

Our Remanufacturing assembly technicians average over 20 years experience with air compression products.

Precision Remanufacturing

All potentially usable parts are thoroughly cleaned, inspected and analyzed. Only those parts that can be brought back to original factory specifications are remanufactured. Every remanufactured air end receives

a new overhaul kit: bearings, gears, seals, sleeves and gaskets.

Extensive Testing

Gardner Denver performs testing that repair houses just don't do. Magnaflux and ultrasonic inspection spot cracked or stressed castings, monochromatic light analysis exposes oil leaks, and coordinate measurement machine inspects to $\pm .0001$ ", insuring that all remanufactured air ends meet factory performance specifications.

Warranty

Gardner Denver backs up every remanufactured air end with a new warranty . . . 18 months from purchase, 12 months from service.

Gardner Denver remanufactured air ends deliver *quality without question . . . year in and year out.*

Call Gardner Denver for information on the air end exchange program and the name of your authorized distributor.

Phone Number: 800-245-4946 or
FAX: 901-542-6159

FOREWORD

Gardner Denver Rotary Screw compressors are the result of advanced engineering and skilled manufacturing. To be assured of receiving maximum service from this machine the owner must exercise care in its operation and maintenance. This book is written to give the operator and maintenance department essential information for day-to-day operation, maintenance and adjustment. Careful adherence to these instructions will result in economical operation and minimum downtime.

DANGER

Danger is used to indicate the presence of a hazard which will cause severe personal injury, death, or substantial property damage if the warning is ignored.

WARNING

Warning is used to indicate the presence of a hazard which can cause severe personal injury, death, or substantial property damage if the warning is ignored.

CAUTION

Caution is used to indicate the presence of a hazard which will or can cause minor personal injury or property damage if the warning is ignored.

NOTICE

Notice is used to notify people of installation, operation or maintenance information which is important but not hazard-related.

This book covers the following models:

DOMESTIC MODELS:

HP	PSIG	Air Cooled	Water Cooled	Parts List	Controller Manual
125	100, 125, 150	EAQQNH	EAQSNH	13-10-508	13-9/10-647
		EAQQNK	EAQSNK	13-10-508	13-9/10-647
	100, 125, 150	EBQQNE	EBQSNE	13-9-559	13-9/10-647
		EBQQNF	EBQSNF	13-9-559	13-9/10-647
	100	EDMQNB	EDMSNB	13-8-507	13-9/10-647
		EDMQNC	EDMSNC	13-8-507	13-9/10-647
150	100, 125, 150	EAQQOH	EAQSOH	13-10-508	13-9/10-647
		EAQQOK	EAQSOK	13-10-508	13-9/10-647
	100, 125, 150	EBQQOE	EBQSOE	13-9-559	13-9/10-647
		EBQQOF	EBQSOF	13-9-559	13-9/10-647
	100, 125	EDMQOB	EDMSOB	13-8-507	13-9/10-647
		EDMQOC	EDMSOC	13-8-507	13-9/10-647
200	100, 125	EDPQPB	EDPSPB	13-8-508	13-9/10-647
		EDPQPC	EDPSPC	13-8-508	13-9/10-647

INTERNATIONAL MODELS:

HP (KW)	PSIG (BARS)	Air Cooled	Water Cooled	Parts List	Controller Manual
100 (75)	100, 125, 150 (6.9, 8.6, 10.3)	EAQQMJ	EAQSMJ	13-10-508X	13-9/10-647
		EAQQML	EAQSML	13-10-508X	13-9/10-647
125 (93)	100, 125, 150 (6.9, 8.6, 10.3)	EAQQNJ	EAQSNJ	13-10-508X	13-9/10-647
		EAQQNL	EAQSNL	13-10-508X	13-9/10-647
		EBQQND	EBQSND	13-9-558X	13-9/10-647
		EBQQNG	EBQSNG	13-9-558X	13-9/10-647
150 (112)	100, 125, 150 (6.9, 8.6, 10.3)	EAQQOJ	EAQSOJ	13-10-508X	13-9/10-647
		EAQQOL	EAQSOL	13-10-508X	13-9/10-647
		EBQQOD	EBQSOD	13-9-558X	13-9/10-647
		EBQQOG	EBQSOG	13-9-558X	13-9/10-647

INSTRUCTIONS FOR ORDERING REPAIR PARTS

When ordering parts, specify Compressor MODEL, Method of Cooling, HORSEPOWER and SERIAL NUMBER (see nameplate on unit). The Serial Number is also stamped on top of the cylinder flange to the right of the inlet housing.

All orders for Parts should be placed with the nearest authorized distributor.

Where NOT specified, quantity of parts required per compressor or unit is one (1); where more than one is

required per unit, quantity is indicated in parenthesis. SPECIFY EXACTLY THE NUMBER OF PARTS REQUIRED.

DO NOT ORDER BY SETS OR GROUPS.

To determine the Right Hand and Left Hand side of a compressor, stand at the motor end and look toward the compressor. Right Hand and Left Hand are indicated in parenthesis following the part name, i.e. (RH) & (LH), when appropriate.

TABLE OF CONTENTS

Remanufactured Air Ends	i
Foreword	ii
Instructions For Ordering Repair Parts	iii
Index	iv
List of Illustrations	ix
Section 1, General Information	1
Section 2, Installation	8
Section 3, Starting & Operating Procedures	16
Section 4, Controls & Instrumentation	18
Section 5, Lubrication, Oil Cooler, Oil Filter & Separator	33
Section 6, Air Filter	45
Section 7, Coupling	47
Section 8, Maintenance Schedule	48
Section 9, Trouble Shooting	49
Warranty	Last Page

INDEX

Actuator, Turn Valve,	23	Controls & Instruments, General Description . .	18
Addition of Oil Between Changes	37	Cooler, Compressor Oil	40
Aftercooler Piping	36	Cooling, Sealing and Lubrication	1
AIR FILTER, SECTION 6	45	COUPLING, SECTION 7	47
Air Filter Element Life	45	Coupling	47
Air Filter Vacuum Switch	21	Alignment	47
Air Filter, Heavy Duty (Standard)	45	Individual Cushion Design	47
Compression Principle	1	Daily Check	17
Air Flow in the Compressor System	1	Decals	6–7
Air Receiver, Auxiliary	10	Discharge Service Line	11
Air-Cooled Units, Location	8	Discharge Thermistor	21
Auto Sentry Operation	18	Drain, Oil Reservoir	9
Auxiliary Air Receiver	10	Draining and Cleaning Oil System	39
Blowdown Valve	19, 21	Electric Motor Grease Recommendations	14
Blowdown Valve Piping	12	Electric Motor Regreasing Interval	15
Change Procedure, Lubricant	37	Electrical Wiring	13
Check, Daily	17	Standard Units	13
Cleaning and Draining Oil System	39	Element Life, Air Filter	45
Cold Ambient Operation	37	Emergency Stop Push-Button	21
Cold Weather Operation	10	Enclosure	9
Cold Weather Operation, Installation for	10	Fan Starter	21
Compressor	1	Filter, Compressor Oil	40
Compressor (GD Eliminator) Oil Separator . . .	42	Filter Element	45
Compressor Capacity Control – EAQ Units Only	22	Filter, Heavy Duty Air (Standard)	45
Compressor Oil Cooler	40	Foreword	ii
Compressor Oil Cooler-Water Cooled Heat Exchanger	40	Foundation	9
Compressor Oil Filter	40	Gauge, Oil Level	19, 38
Compressor Oil System	33	GENERAL INFORMATION, SECTION 1	1
Compressor Oil System Check	43	Grease Recommendations, Electric Motor	14
Control Devices	18	Grounding	14
Control Devices, Other	18	Heat Exchanger, Compressor Oil Cooler, Water-Cooled	40
Control Piping	10	Heat Exchanger (Oil) Piping	36
Control Transformer	21	High Temperature Operation	33
Controller	18	Inlet Line	10
CONTROLS & INSTRUMENTS, SECTION 4	18		

INDEX

<p>Inlet Screen and Tube 46</p> <p>Inlet Valve 20</p> <p>INSTALLATION, SECTION 2 8</p> <p>Installation, General 8</p> <p>Installation for Cold Weather Operation 10</p> <p>Lifting Unit 8</p> <p>Line, Discharge Service 11</p> <p>Line, Inlet 10</p> <p>Location 8</p> <p style="padding-left: 20px;">Air-Cooled Units 8</p> <p style="padding-left: 20px;">Water-Cooled Units 9</p> <p>Lubricant, Recommended 33</p> <p>Lubricant Change Procedure 37</p> <p>Lubrication, Motor 14</p> <p>Lubrication, Cooling and Sealing 1</p> <p>LUBRICATION, OIL COOLER, OIL FILTER & SEPARATOR, SECTION 5 33</p> <p>Main Starter 22</p> <p>MAINTENANCE SCHEDULE, SECTION 8 ... 48</p> <p>Minimum Discharge Pressure Valve 19</p> <p>Moisture in the Oil System 38</p> <p>Moisture Separator/Trap 10</p> <p>Motor Grease Recommendations 14</p> <p>Motor Lubrication 14</p> <p>Motor Regreasing Interval 15</p> <p>Oil Change Interval 38</p> <p>Oil Cooler, Compressor 40</p> <p>Oil Filter, Compressor 40</p> <p>Oil Level Gauge 19, 38</p> <p>Oil Reservoir 42</p> <p>Oil Reservoir Drain 9</p> <p>Oil Separator</p> <p style="padding-left: 20px;">Compressor (GD Eliminator) 42</p> <p style="padding-left: 20px;">Inspection 43</p> <p style="padding-left: 20px;">Oil Carryover 42</p> <p style="padding-left: 20px;">Removal for Inspection or Replacement ... 43</p> <p>Oil Specifications – EAQ and EBQ 33</p>	<p>Oil Specifications – EDM and EDP 33</p> <p>Oil System</p> <p style="padding-left: 20px;">Compressor 33</p> <p style="padding-left: 20px;">Draining and Cleaning 39</p> <p>Oil System Check 43</p> <p style="padding-left: 20px;">Air and Oil Discharge Temperature 43</p> <p style="padding-left: 20px;">Compressor Oil Inlet Temperature 43</p> <p style="padding-left: 20px;">Oil Cooler Oil Pressure Differential 43</p> <p style="padding-left: 20px;">Oil Cooler Temperature Differential 44</p> <p style="padding-left: 20px;">Oil Cooler Water Pressure Differential 44</p> <p style="padding-left: 20px;">Oil Inlet Pressure 43</p> <p>Operation</p> <p style="padding-left: 20px;">Cold Ambient 37</p> <p style="padding-left: 20px;">High Temperature 33</p> <p>Optional Switches 21</p> <p>Parallel Piping 13</p> <p>Piping</p> <p style="padding-left: 20px;">Aftercooler 36</p> <p style="padding-left: 20px;">Blowdown Valve 12</p> <p style="padding-left: 20px;">Control 10</p> <p style="padding-left: 20px;">Heat Exchanger (Oil) 36</p> <p style="padding-left: 20px;">Parallel 13</p> <p style="padding-left: 20px;">Series 13</p> <p style="padding-left: 20px;">Water 12</p> <p>Pressure Differential Gauging 43</p> <p>Pressure Regulator 21</p> <p>Prestart-Up Instructions 16</p> <p style="padding-left: 20px;">Air Filter 16</p> <p style="padding-left: 20px;">Coupling 16</p> <p style="padding-left: 20px;">Electrical 16</p> <p style="padding-left: 20px;">Enclosure 17</p> <p style="padding-left: 20px;">Grounding 16</p> <p style="padding-left: 20px;">Operating Mode 17</p> <p style="padding-left: 20px;">Piping 16</p> <p style="padding-left: 20px;">Rotation 16</p> <p style="padding-left: 20px;">System Pressure 17</p> <p>Purge Air Valve 22</p>
--	---

INDEX

<p>Recommended Lubricant 33</p> <p>Regreasing Interval, Electric Motor 15</p> <p>Regulator, Pressure 21</p> <p>Relief Valve 18</p> <p>Remote Mounted Elevated Cooler Assembly Procedure 36</p> <p>Repair Parts, Ordering Instructions iii</p> <p>Reservoir, Oil 42</p> <p>Reservoir Pressure Transducer 21</p> <p>Reservoir Thermistor 21</p> <p>Safety Precautions 4, 5</p> <p>Sealing, Lubrication and Cleaning 1</p> <p>Separator, Compressor (GD Eliminator) Oil 42</p> <p>Series Piping 13</p> <p>SERVICE CHECK LIST, AIR FILTER 48</p> <p>Service Check List 48</p> <p> Every 1000 Hours Operation 48</p> <p> Every 125 Hours Operation 48</p> <p> Every 6000 Hours Operation 48</p> <p> Every 8 Hours Operation 48</p> <p> Every Year 48</p> <p> Motor Lubrication 48</p> <p> Oil Separator 48</p> <p>Shuttle Valve 21</p> <p>Solenoid Valves IVC and IVO 20</p> <p>Solenoid Valves TVC and TVO 22</p> <p>Specifications, OIL, EDM and EDP 33</p> <p>Specifications, Oil, EAQ and EBQ 33</p> <p>Starter</p> <p> Fan 21</p> <p> Main 22</p> <p>STARTING & OPERATING PROCEDURES, SECTION 3 16</p> <p>Starting the Unit 17</p> <p> Unit Cold 17</p> <p> Unit Hot 17</p> <p>Stopping the Unit 17</p> <p>Strip, Terminal 21</p>	<p>Switch, Air Filter Vacuum 21</p> <p>Switches, Optional 21</p> <p>System Pressure Transducer 21</p> <p>Terminal Strip 21</p> <p>Thermal Control (Thermostatic Mixing) Valve 40</p> <p>Thermistor</p> <p> Discharge 21</p> <p> Reservoir 21</p> <p>Transducer</p> <p> Reservoir Pressure 21</p> <p> System Pressure 21</p> <p>Transformer, Control 21</p> <p>TROUBLE SHOOTING, SECTION 9 49</p> <p>Tube, Inlet 46</p> <p>Turn Valve 1, 22</p> <p>Turn Valve Actuator – EAQ Units Only 23</p> <p>Valve</p> <p> Blowdown 19, 21</p> <p> Inlet 20</p> <p> Minimum Discharge Pressure 19</p> <p> Purge Air 22</p> <p> Relief 18</p> <p> Shuttle 21</p> <p> Solenoid IVC and IVO 20</p> <p> Solenoid TVC and TVO 22</p> <p> Thermal Control (Thermostatic Mixing) 40</p> <p> Turn 22</p> <p> Water Flow Control 41</p> <p> Water Shutoff Valve 41</p> <p>Warranty Last Page</p> <p>Water Flow Control Valve for Heat Exchanger 41</p> <p>Water Piping 12</p> <p>Water Shutoff Valve – Water–Cooled Heat Exchanger 41</p> <p>Water–Cooled Units, Location 9</p> <p>Wiring, Electrical 13</p>
---	--

LIST OF ILLUSTRATIONS

Figure 1–2	Starter Box	2
Figure 1–1	Compression Cycle	1
Figure 1–2	Starter Box	2
Figure 1–3	Package – Controller & Starters	2
Figure 1–4	Package – Drive Motor & Air Filter	2
Figure 1–5	Package – Oil Filter, Oil Level Gauge, Mixing Valve, Minimum Press. Valve & Check Valve ..	3
Figure 1–6	Package – Air/Oil Flow Diagram	3
Figure 2–1	Typical Compressor Room	8
Figure 2–2	Air Flow Chart	8
Figure 2–3	Cold Weather Installation	9
Figure 2–4	Inlet Line Lengths	11
Figure 2–5	Heat Exchanger (Oil Cooler) Approximate Water Flow	11
Figure 2–6	Aftercooler Approximate Water Flow	12
Figure 2–7	Series Piping	13
Figure 2–8	Parallel Piping	13
Figure 4–1	Schematic Tubing Diagram	19
Figure 4–2	Blowdown Valve	19
Figure 4–3	Minimum Discharge Pressure Valve	20
Figure 4–4	Inlet Valve	20
Figure 4–5	Shuttle Valve	21
Figure 4–6	Turn Valve – EAQ Units Only	22
Figure 4–7	Control Schematic – Compressor Unloaded–Constant Speed Mode, EBQ, EDM & EDP ...	24
Figure 4–8	Control Schematic – Compressor at Full Load–Constant Speed Mode, EBQ, EDM & EDP ..	25
Figure 4–9	Control Schematic – Compressor Unloaded – Low Demand Mode, EBQ, EDM & EDP	26
Figure 4–10	Control Schematic – Compressor at Full Load, EAQ Units Only	27
Figure 4–11	Control Schematic – Compressor Fully Unload – Low Demand Mode Switch Off, EAQ	28
Figure 4–12	Control Schematic – Compressor Fully Loaded – Low Demand Mode Switch On, EAQ ...	29
Figure 4–13	Wiring Diagram – 206EDM546	30
Figure 4–14	Wiring Diagram – 207EDM546	31
Figure 4–15	Wiring Diagram – 202EAQ546	32
Figure 5–1	Flow Diagram	34
Figure 5–2	Oil Flow Diagram – Remote Overhead Mounted	35
Figure 5–3	Cooler Drain Detail	36
Figure 5–4	Oil Level Gauge	38
Figure 5–5	Oil Change Interval	38
Figure 5–6	Approximate Oil System Capacities	39
Figure 5–7	Water Control Valve	41
Figure 5–8	Dew Point Temperature vs. Ambient Temperature, (100% Relative Humidity)	42
Figure 5–9	Oil Separator	42
Figure 6–1	Heavy Duty Air Filter (Standard)	45
Figure 7–1	Installation of Coupling Cushions	47

SECTION 1

GENERAL INFORMATION

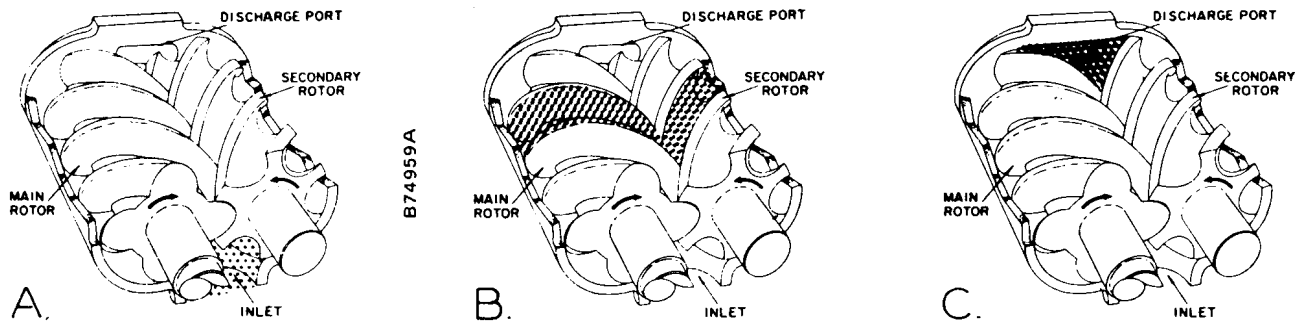

FIGURE 1-1 – COMPRESSION CYCLE

COMPRESSOR – The Gardner Denver Rotary Screw compressor is a single stage, positive displacement rotary machine using meshing helical rotors to effect compression. Both rotors are supported between high capacity roller bearings located outside the compression chamber. Single width cylindrical roller bearings are used at the inlet end of the rotors to carry part of the radial loads. Tapered roller bearings at the discharge end locate each rotor axially and carry all thrust loads and the remainder of the radial loads.

COMPRESSION PRINCIPLE (FIGURE 1-1) – Compression is accomplished by the main and secondary rotors synchronously meshing in a one-piece cylinder. The main rotor has four (4) helical lobes 90° apart. The secondary rotor has six (6) matching helical grooves 60° apart to allow meshing with main rotor lobes.

The air inlet port is located on top of the compressor cylinder near the drive shaft end. The discharge port is near the bottom at the opposite end of the compressor cylinder. *Figure 1-1 is an inverted view to show inlet and discharge ports.* The compression cycle begins as rotors unmesh at the inlet port and air is drawn into the cavity between the main rotor lobes and secondary rotor grooves (A). When the rotors pass the inlet port cut-off, air is trapped in the interlobe cavity and flows axially with the meshing rotors (B). As meshing continues, more of the main rotor lobe enters the secondary rotor groove, normal volume is reduced and pressure increases.

Oil is injected into the cylinder to remove the heat of compression and seal internal clearances. Volume reduction and pressure increase continues until the air/oil mixture trapped in the interlobe cavity by the rotors passes the discharge port and is released to the oil res-

ervoir (C). Each rotor cavity follows the same “fill-compress-discharge” cycle in rapid succession to produce a discharge air flow that is continuous, smooth and shock free.

AIR FLOW IN THE COMPRESSOR SYSTEM (FIGURE 5-1, page 34) – Air enters the air filter and passes through the inlet unloader valve to the compressor. After compression, the air/oil mixture passes into the oil reservoir where most of the entrained oil is removed by velocity change and impingement and drops back into the reservoir. The air and remaining oil passes into the separator and separator housing where the oil is separated and passes through tubing connecting the separator housing and compressor. The air passes through the minimum pressure valve, discharge check valve and cooler, then to the plant air lines.

LUBRICATION, COOLING AND SEALING – Oil is forced by air pressure from the oil reservoir through the oil cooler, thermostatic mixing valve, and oil filter and discharges into the compressor main oil gallery. A portion of the oil is directed through internal passages to the bearings, gears and shaft oil seal. The balance of the oil is injected directly into the compression chamber to remove heat of compression, seal internal clearances and lubricate the rotors.

TURN VALVE (EAQ UNITS ONLY) – The turn valve is a rotary helical valve located on the discharge side of the cylinder toward the inlet end. The valve opens and closes ports in the cylinder which communicates with the inlet passage. This varies the compressor rotor volume to match the demand for air, thus reducing the part-load power requirement.

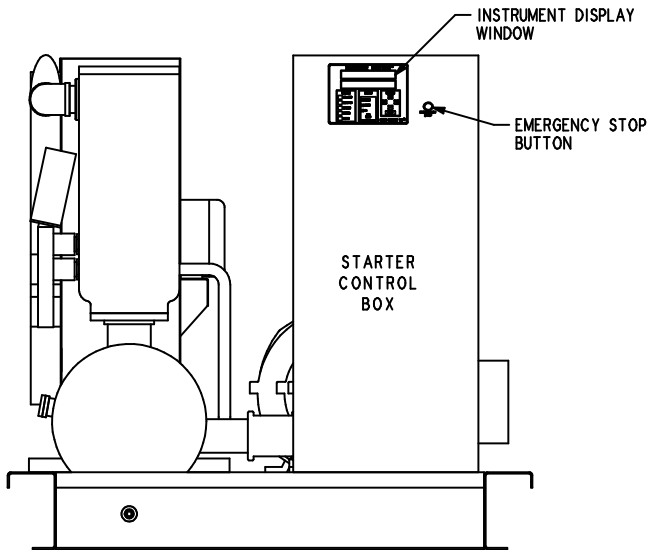

FIGURE 1-2 - STARTER BOX

200EDM797-A
(Ref. Drawing)

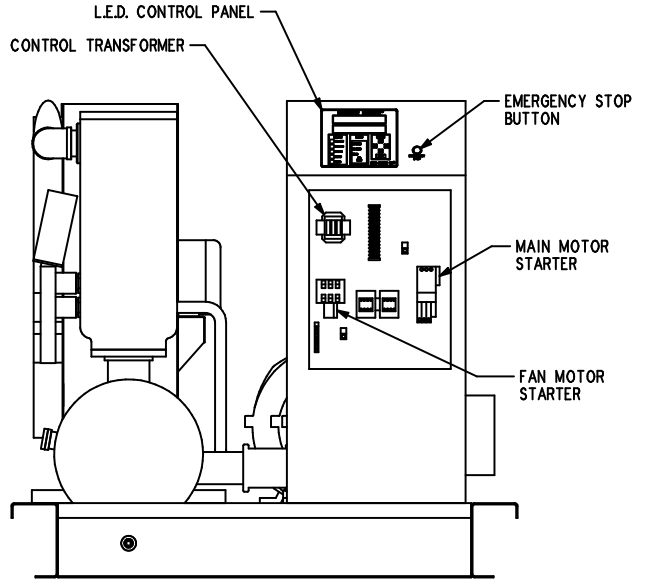
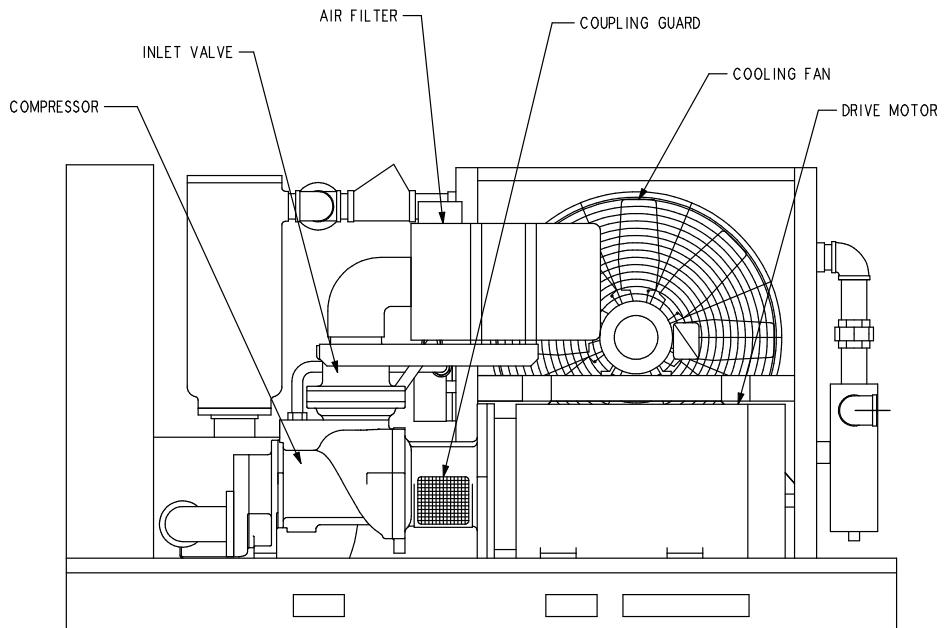

FIGURE 1-3 - PACKAGE - CONTROLLER & STARTERS



200EDM797
(Ref. Drawing)

FIGURE 1-4 - PACKAGE - DRIVE MOTOR & AIR FILTER

200EDM797
(Ref. Drawing)

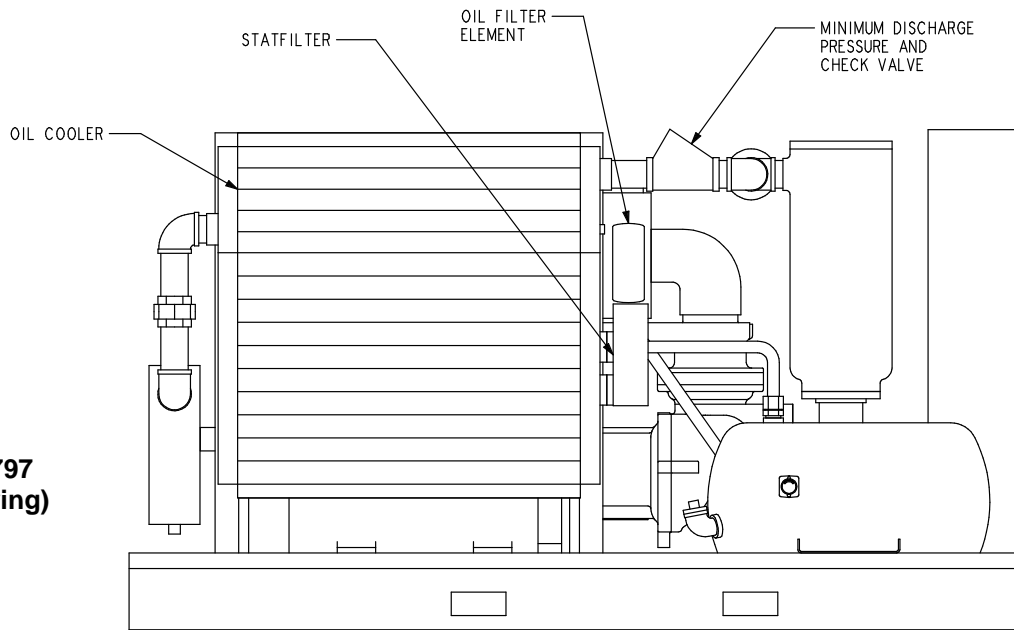
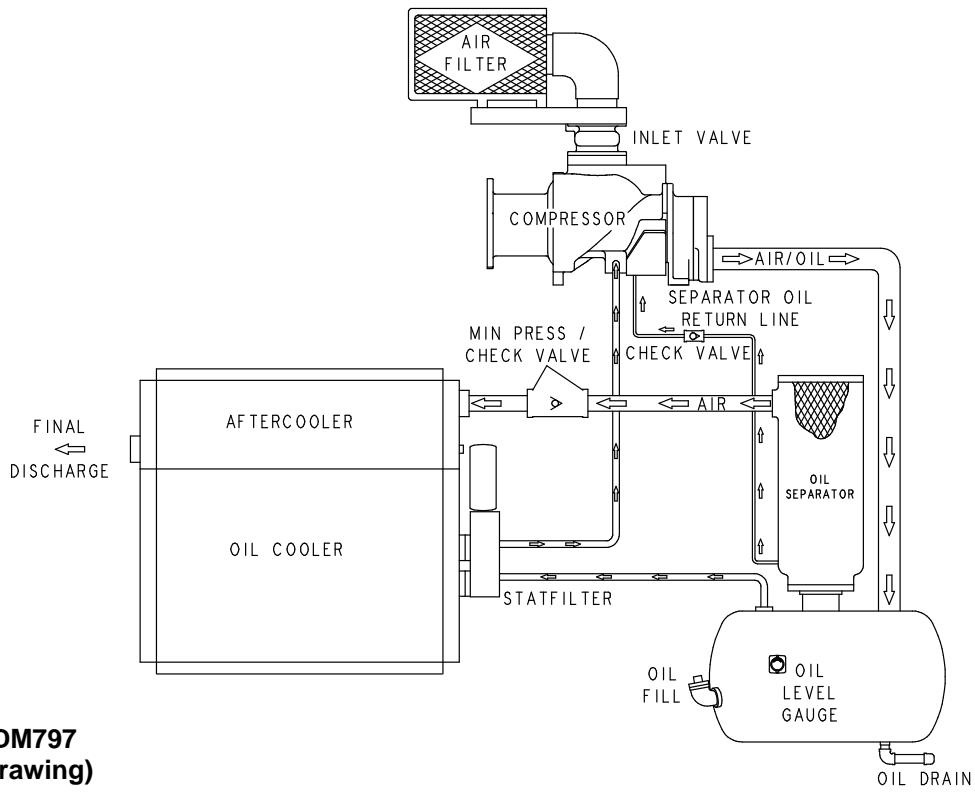

FIGURE 1-5 – PACKAGE – OIL FILTER, OIL LEVEL GAUGE, MIXING VALVE,
MINIMUM PRESSURE VALVE & CHECK VALVE



202EDM797
(Ref. Drawing)

FIGURE 1-6 – PACKAGE – AIR/OIL FLOW DIAGRAM

SAFETY PRECAUTIONS

Safety is everybody's business and is based on your use of good common sense. All situations or circumstances cannot always be predicted and covered by established rules. Therefore, use your past experience, watch out for safety hazards and be cautious.

Some general safety precautions are given below:

DANGER

Failure to observe these notices could result in injury to or death of personnel.

- **Keep fingers and clothing away from revolving fan, drive coupling, etc.**
- **Do not use the air discharge from this unit for breathing – not suitable for human consumption.**
- **Do not loosen or remove the oil filler plug, drain plugs, covers, the thermostatic mixing valve or break any connections, etc., in the compressor air or oil system until the unit is shut down and the air pressure has been relieved.**
- **Electrical shock can and may be fatal.**
- **Compressor unit must be grounded in accordance with the National Electrical Code. A ground jumper equal to the size of the equipment ground conductor must be used to connect the compressor motor base to the unit base.**
- **Fan motors must remain grounded to the main base through the starter mounting panel in accordance with the National Electrical Code.**
- **Open main disconnect switch, tag and lockout before working on the control.**
- **Disconnect the compressor unit from its power source, tag and lockout before working on the unit – this machine is automatically controlled and may start at any time.**

 **WARNING**

Failure to observe these notices could result in damage to equipment.

- **Stop the unit** if any repairs or adjustments on or around the compressor are required.
- **Disconnect the compressor** unit from its power source, tag and lockout before working on the unit – this machine is automatically controlled and may start at any time.
- **An Excess Flow Valve** should be on all compressed air supply hoses exceeding 1/2 inch inside diameter. (OSHA Regulation, Section 1926.302)
- **Do not exceed the rated maximum pressure values** shown on the nameplate.
- **Do not operate unit** if safety devices are not operating properly. Check periodically. Never bypass safety devices.

DECALS



206EAQ077

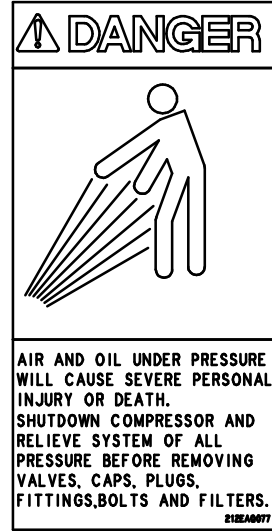

212EAQ077

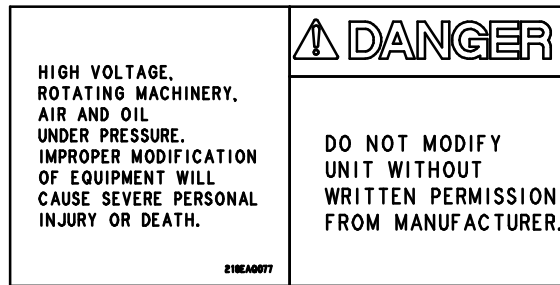

218EAQ077

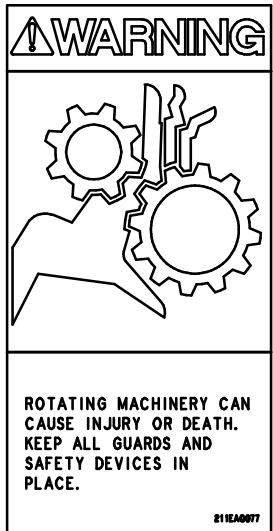

211EAQ077

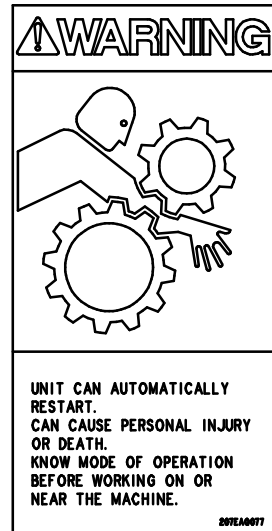

207EAQ077

DECALS

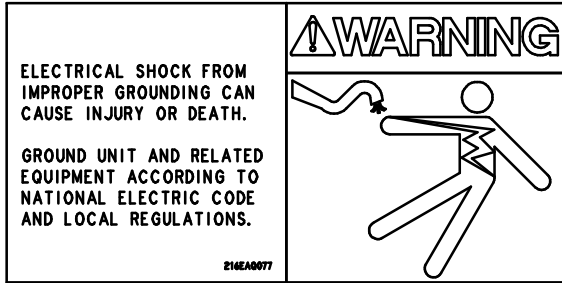

216EAQ077

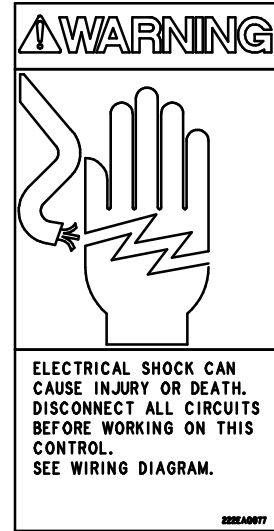

222EAQ077

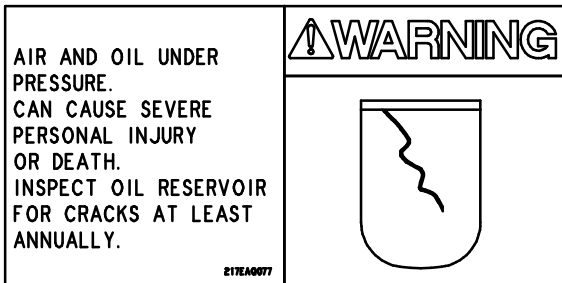

217EAQ077

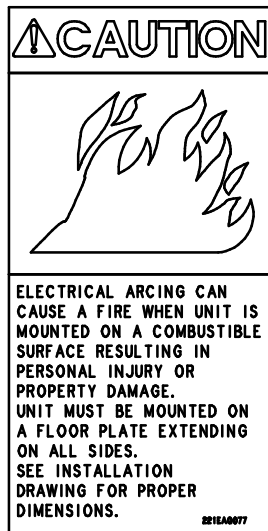

221EAQ077

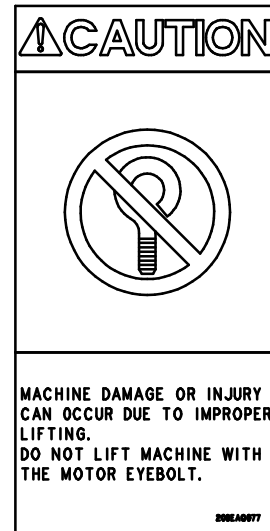

208EAQ077

SECTION 2 INSTALLATION

GENERAL – On receipt of the unit, check for any damage that may have been incurred during transit. Report any damage or missing parts as soon as possible.

 **CAUTION**

Do not electric weld on the compressor or base; bearings can be damaged by passage of current.

LIFTING UNIT – Proper lifting and/or transporting methods must be used to prevent damage. Lifting slots are provided in the base for towmotor use. The unit may also be moved into location by rolling on bars.

 **CAUTION**

Lift compressor unit by base only. Do not use other places such as motor, compressor or discharge manifold piping as lifting points.

 **DANGER**

The eyebolts or lugs provided on the motor are for lifting the motor only and should not be used to lift any additional weight. All eyebolts must be securely tightened. When lifting the motor the lifting angle must not exceed 15 degrees. Failure to observe this warning may result in damage to equipment or personal injury.

LOCATION – The compressor should be installed, whenever possible, in a clean, well-lighted, well-ventilated area with ample space all around for maintenance. Select a location that provides a cool, clean, dry source of air. In some cases it may be necessary to install the air filter at some distance from the compressor to obtain proper air supply.

Both the air-cooled and water-cooled units require

cooling air as well as air to the compressor inlet. Proper ventilation **MUST** be provided; hot air must be exhausted from the compressor operating area. A typical inlet-outlet air flow arrangement is shown in FIGURE 2-1.

Air-Cooled Units – A combination oil/aftercooler is supplied as standard equipment on all air-cooled units. The air-cooled unit with the standard enclosure requires sufficient flow, FIGURE 2-2, for the compressor oil/aftercooling system and for electric motor cooling. Air is drawn into the unit at the motor side of the enclosure and is exhausted at the oil cooler side. Do not block the air flow to and from the unit. Allow three and one-half (3-1/2) feet (1.1 M) to the nearest obstruction on the starter end and control box end of the unit. Allow three (3) feet (.9 M) to the nearest obstruction above and on other sides of unit. For continuous efficiency, oil cooler cores must be periodically cleaned with either vacuum or compressed air. If wet cleaning is required, shield motor and spray on a mild soap solution and flush with clean water.

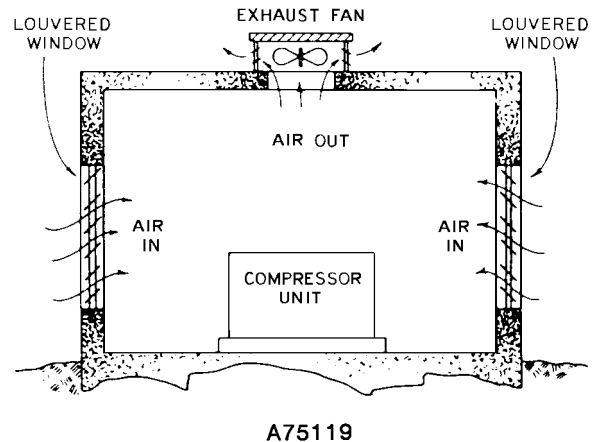

FIGURE 2-1 – TYPICAL COMPRESSOR ROOM

Minimum Air Flow* For Compression And Cooling – Cubic Feet/Minute (Cubic Meters/Minute)		
HP (KW)	Air Cooled	Water Cooled
100, 125, 150, 200 (75, 93, 112, 150)	17,000 (481)	4,000 (113 M ³ /min.)

* 80° F (27° C) Inlet Air

FIGURE 2-2 – AIR FLOW CHART

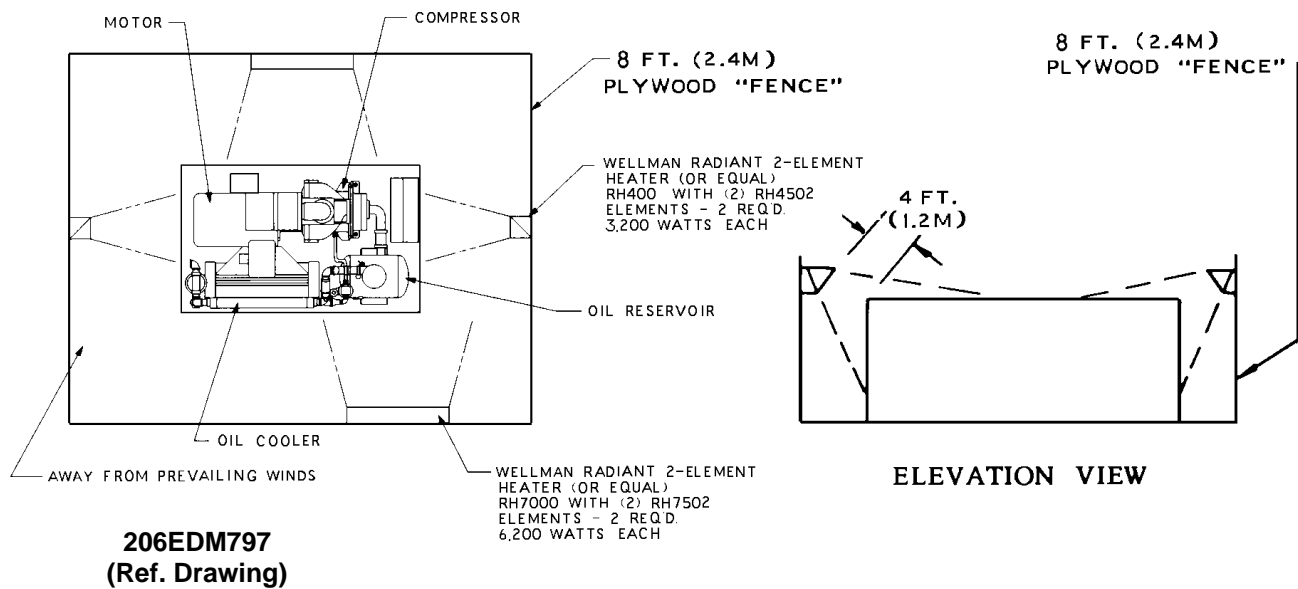

FIGURE 2-3 – COLD WEATHER INSTALLATION

⚠ WARNING

For aluminum oil coolers, do not use any cleaning solution that is not compatible with aluminum. Use of improper solution may result in damage to the cooler.

Water-Cooled Units – The water-cooled unit with the standard enclosure requires sufficient air flow, FIGURE 2-2, page 8, for electric motor cooling. Air is drawn into the unit at the top of the enclosure and is exhausted at the motor side. Do not block air flow to and from unit. Allow three and one-half (3-1/2) feet (1.1 M) to the nearest obstruction on the starter end and control box side of the unit. Allow three (3) feet (.9 M) to the nearest obstruction above and on other sides of the unit.

FOUNDATION – The G-D Rotary Screw compressor requires no special foundation, but should be mounted on a smooth, solid surface. Whenever possible install the unit near level. Temporary installation may be made at a maximum 10° angle lengthwise or 10° sidewise.

Mounting bolts are not normally required. However, installation conditions such as piping rigidity, angle of tilt, or danger of shifting from outside vibration or moving vehicles may require the use of mounting bolts and shims to provide uniform support for the base.

OIL RESERVOIR DRAIN – The oil drain is piped from the bottom of the reservoir to the side of the frame. This

drain is approximately 4.50 inches (115 mm) above the floor level. If this is not sufficient to conveniently drain the oil some other methods of providing drain are:

1. Elevate the compressor unit on a suitable structure to obtain the desired drain height.

⚠ CAUTION

If the compressor unit base is raised above floor level, the space between the floor and the base bottom must be closed with solid material all around to prevent recirculation of hot air from the oil cooler end and over temperature operation.

2. Construct an oil sump or trough below the floor level and pump or bail the drained oil.
3. Pump oil from the reservoir filler opening or drain to a container.

ENCLOSURE – The compressor, electric motor, oil cooler and aftercooler are mounted inside the enclosure. Service doors are provided for maintenance access. Be sure to allow enough space around the unit for the doors to open completely.

Any of the enclosure doors may be removed by opening the door and lifting it up slightly to disengage the hinges.

 **DANGER**

Do not operate the compressor with the fan and coupling guard removed. Exposed fan and belts may cause injury to personnel.

The motor inspection/air filter service panel is held by two latches and lifts away from the enclosure. The air outlet panel is attached by screws to the enclosure and is not readily removeable.

INSTALLATION FOR COLD WEATHER OPERATION (FIGURE 2–3, page 9) – It is recommended that the unit be installed inside a shelter that will be heated to temperatures above freezing (32°F, 0°C). This will eliminate many of the problems associated with operating units in cold climates where freezing rain, drifting snow, freezing condensate and bitter cold temperatures are encountered..

Refer to Engineering Data Sheet 13–9–411 for the advantages of using the heat recovered from rotary compressors. This heat recovery could easily pay for an adequate shelter for the unit.

When an outside installation must be made, the precautions required will depend on the severity of the environment. The following are general guidelines for outside installations:

Cold Weather (Down To +10°F, –12°C)

1. Be sure all drains, traps, and control lines, including pressure transducer lines are heated to avoid freezing of condensate. Heat tape with thermostat control is generally satisfactory for this purpose and can be obtained at various local plumbing or hardware outlets at nominal cost.
2. If an air-cooled aftercooler is to be used, provisions to bypass the aftercooler must be made. Since cold air contains very little moisture, successful operation can be achieved without the aftercooler.
3. Provide at least some simple shelter such as a plywood windbreak to protect against drifting snow.
4. Use only Gardner Denver® AEON™ 9000 SP lubricant.
5. Monitor the unit carefully during start-up and operation to be sure it is functioning normally.
6. Specify NEMA 4 enclosure for electrical devices.

Extreme Cold Weather Operation (Down To –40°F, –40°C)

In addition to the above, the following should be provided:

1. It will be necessary to provide shutters or to block off part of the cooler in some manner since the cooler is greatly oversized for operation in these low temperatures. Since shutters are not provided as a factory option, blocking off a portion of the cooler with plywood should be satisfactory.
2. Auto operation should not be used in extreme environments.
3. Some means of providing heat during shutdown should be provided. There are various methods to accomplish this, but since openings are not provided for sump heaters, the use of radiant heaters is recommended. The heaters should be sized to provide at least a +10°F (–12°C) environment for coolers, motor and sump. FIGURE 2–3, page 9, shows how these might be located in a typical installation and sizes required.

Remember unsheltered (outside) installations should be avoided where possible. Installation next to a heated building where enough heat can be used to keep the compressor room above freezing will save many complications in the operation and installation of the unit.

Refer to Engineering Data Sheet 13–9–411, available from an authorized Gardner Denver distributor, for the advantages of using the heat recovered from rotary compressors. This heat recovery could easily pay for an adequate shelter for the unit.

AUXILIARY AIR RECEIVER – An auxiliary air receiver is not required if the piping system is large and provides sufficient storage capacity to prevent rapid cycling. When used, an air receiver should be of adequate size, provided with a relief valve of proper setting, a pressure gauge and a means of draining condensate.

MOISTURE SEPARATOR/TRAP – Since the unit is equipped with a built-in aftercooler, a combination moisture separator and trap is furnished with the unit.

CONTROL PIPING – Control piping is not necessary since the Rotary Screw compressor unit is factory wired and piped for the control system specified.

INLET LINE – Where an inlet line is used between the air filter and the compressor, it must be thoroughly cleaned on the inside to prevent dirt or scale from entering the compressor. **If welded construction is used, the line must be shot blasted and cleaned to remove welding scale.** In either case, the inlet line must be coated internally by galvanizing or painting with a moisture and oil-proof sealing lacquer. Up to ten (10) feet (3 meters) in length, the inlet line should be the full size of the inlet opening on the compressor. If an extra-long line is necessary, the pipe size should be in-

Length of Inlet Line	Diameter of Pipe Size
0 to 10 Feet (0 to 3 Meters)	Same as Compressor Inlet Opening
10 to 17 Feet (3 to 5 Meters)	One Size Larger Than Inlet Opening
17 to 38 Feet (5 to 11.5 Meters)	Two Sizes Larger Than Inlet Opening

FIGURE 2-4 – INLET LINE LENGTHS

creased according to Inlet Line Length Chart FIGURE 2-4.

Accessibility for inlet air filter servicing must be considered when relocating the filters from the unit to a remote location.

DISCHARGE SERVICE LINE – The discharge service line connection on both water-cooled and air-cooled

units is made at the right hand corner of the unit, viewed from the opposite end from control panel side. When manifolding two or more rotary screw units on the same line, each unit is isolated by the check valve in the unit discharge line. If a rotary screw unit is manifolded to another compressor, be sure the other compressor has a check valve in the line between the machine and the manifold. If a rotary screw and a reciprocating com-

HEAT EXCHANGER (DOMESTIC)							
HP	Model	Water Temperature to Heat Exchanger Gallons/minute				Maximum Water Flow GPM	Approx. Water Pressure Drop @ 90° F Water Temp. PSI
		60° F.	70° F.	80° F.	90° F.		
125 HP	EAQSN_	12.0	15.0	20.0	30.0	40.0	4.0
125 HP	EBQSN_	12.0	15.0	20.0	30.0	40.0	4.0
125 HP	EDMSN_	12.0	15.0	20.0	30.0	40.0	4.0
150 HP	EAQSO_	13.4	16.7	22.3	33.5	40.0	4.5
150 HP	EBQSO_	13.4	16.7	22.3	33.5	40.0	4.5
150 HP	EDMSO_	13.4	16.7	22.3	33.5	40.0	4.5
200 HP	EDPSP_	19.3	24.1	32.1	40.0*	40.0	5.0

* 85° F. Max. Water Temperature

HEAT EXCHANGER (INTERNATIONAL)							
KW	Model	Water Temperature to Heat Exchanger Liters/Second				Maximum Water Flow L/S	Approx. Water Press. Drop @ 32° C. Water Temp. Bar
		16° C.	21° C.	27° C.	32° C.		
75 KW	EAQSM_	.57	.70	.94	1.41	2.52	.3 Bar
93 KW	EBQSN_	.76	.95	1.26	1.89	2.52	.3 Bar
93 KW	EAQSN_	.76	.95	1.26	1.89	2.52	.3 Bar
112 KW	EBQSO_	.85	1.05	1.41	2.11	2.52	.3 Bar
112 KW	EAQSO_	.85	1.05	1.41	2.11	2.52	.3 Bar

FIGURE 2-5 – HEAT EXCHANGER (OIL COOLER) APPROXIMATE WATER FLOW

AFTERCOOLER (DOMESTIC)							
HP	Model	Water Temperature to Heat Exchanger Gallons/minute				Maximum Water Flow GPM	Approx. Water Pressure Drop @ 90° F Water Temp. PSI
		60° F.	70° F.	80° F.	90° F.		
125 HP	EAQSN_	2.1	2.6	3.4	5.2	55	Less than 1 PSI for any flow rate shown in the table.
125 HP	EBQSN_	2.1	2.6	3.4	5.2	55	
125 HP	EDMSN_	2.1	2.6	3.4	5.2	55	
150 HP	EAQSO_	2.7	3.3	4.5	6.7	55	
150 HP	EBQSO_	2.7	3.3	4.5	6.7	55	
150 HP	EDMSO_	2.7	3.3	4.5	6.7	55	
200 HP	EDPSP_	3.6	4.5	6.0	9.0	90	

AFTERCOOLER (INTERNATIONAL)							
KW	Model	Water Temperature to Heat Exchanger Liters/Second				Maximum Water Flow L/S	Approx. Water Press. Drop @ 32° C. Water Temp. Bar
		16° C.	21° C.	27° C.	32° C.		
75 KW	EAQSM_	.11	.14	.19	.28	3.47	Less than .1 Bar for any flow rate shown in the table.
93 KW	EBQSN_	.13	.16	.21	.33	3.47	
93 KW	EAQSN_	.13	.16	.21	.33	3.47	
112 KW	EBQSO_	.17	.21	.28	.42	3.47	
112 KW	EAQSO_	.17	.21	.28	.42	3.47	

FIGURE 2-6 – AFTERCOOLER APPROXIMATE WATER FLOW

pressor are manifolded together, an air receiver must be located between the two units.

 DANGER
<p>Discharge air used for breathing will cause severe injury or death.</p> <p>Consult filtration specialists for additional filtration and treatment equipment to meet health and safety standards.</p>

BLOWDOWN VALVE PIPING – The blowdown valve is fitted with a muffler for operation indoors. If the instal-

lation requires, the muffler may be removed and the blowdown valve piped to the outside with a pipe size the same as the blowdown valve outlet connection.

WATER PIPING (Water-Cooled Heat Exchanger Models Only) – On machines equipped with water-cooled heat exchangers, the water inlet and outlet connections are located in the unit base flange on the left side of the unit.

The water source should be capable of supplying up to the maximum flow shown in FIGURE 2-5, page 11, and FIGURE 2-6, above, at a minimum pressure of 40 psig (2.8 Bars); maximum allowable water pressure is 150 psig (10.3 Bars). The water flow rates shown are approximate and a guide to sizing piping, cooling tower and other water system equipment.

The heat exchanger system is designed to operate with water inlet temperatures from 60° to 90° F (16° to 32° C) and a water outlet temperature not to exceed 110° F

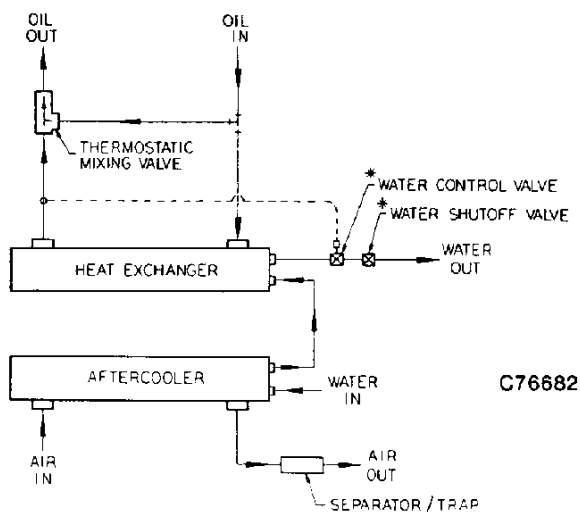

FIGURE 2-7 – SERIES PIPING

(43° C). If water cooler than 60° F is used, high water outlet temperatures (over 110° F, 43° C) will be experienced along with shortened heat exchanger life caused by tube fouling and corrosion. If water warmer than 90° F (32° C) is used, higher compressor oil inlet temperatures and high water usage will result.

Most water systems will require control of impurities: filtration, softening or other treatment. See “Compressor Oil Cooler – Water-Cooled Heat Exchanger” for more information on the water system.

SERIES PIPING (FIGURE 2-7) – Water flow must be through aftercooler first for effective cooling of discharge air and is so piped on the standard water-cooled unit.

PARALLEL PIPING (FIGURE 2-8) – A separate water control valve is required to control the discharge air temperature. If a remote (externally mounted) water-cooled aftercooler is piped in parallel with the heat exchanger, provide a separate water control valve for the aftercooler and pipe separate inlet water lines to both the aftercooler and heat exchanger.

The water control valve is to be adjusted to maintain oil out of the heat exchanger within the 140° to 150° F (60° to 66° C) range regardless of inlet water flow or temperature as long as a minimum flow for a given temperature is met (FIGURE 2-5, page 11, and FIGURE 2-6, page 12. See Section 5, page 33, for adjustment instructions and maximum allowable lubricant temperature.

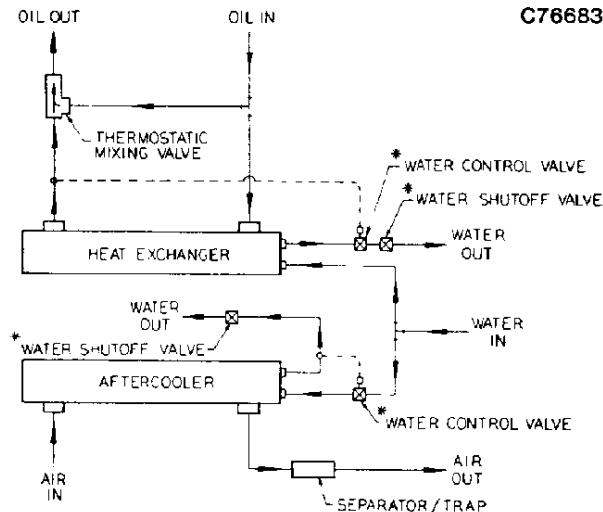

FIGURE 2-8 – PARALLEL PIPING

ELECTRICAL WIRING – Standard Units – The Rotary Screw compressor is factory wired for all starter to motor and control connections for the voltage specified on the order. It is necessary only to connect the unit starter to the correct power supply. The standard unit is supplied with an open drip-proof motor, a NEMA 12 starter and control enclosure. See “Location” paragraph, page 8, for distance to the nearest obstruction on starter and control box sides of the unit.

Lower operating voltages (200/208) require that the unit starter be remote mounted since the starter is too large to be mounted within the control enclosure. If not supplied with the compressor unit, the starter is to be a size 6 full voltage non-reversing type in NEMA (CEMA) enclosure suitable for the environment, with two (2) rejection type control circuit fuses (size according to motor starter manufacturer’s standard), a 200 (208) volt coil, and three (3) overload heaters for 200 (208) volt 100 HP (75 KW), 1.15 service factor motor. The overload heaters are to be selected according to starter manufacturer’s tables based on motor nameplate full load amperage.

WARNING

Electrical shock can cause injury or death. Open main disconnect switch, tag and lockout before working on starter/control box.

GROUNDING – Equipment must be grounded in accordance with Table 250–95 of the National Electrical Code.

 WARNING
Failure to properly ground the compressor package could result in controller malfunction.

MOTOR LUBRICATION – Long time satisfactory operation of an electric motor depends in large measure on proper lubrication of the bearings. The following charts show recommended grease qualities and regreasing intervals for ball bearing motors. For additional information refer to the motor manufacturer's instructions. The following procedure should be used in regreasing:

1. Stop the unit.
2. Disconnect, tag and lockout the unit from the power supply.

3. Remove the relief plug and free hole of hardened grease.
4. Wipe lubrication fitting clean and add grease with a hand-operated grease gun.
5. Leave the relief plug temporarily off. Reconnect the unit and run for about 20 minutes to expell the excess grease.
6. Stop the unit. Replace the relief plug.
7. Restart the unit.

 WARNING
Rotating machinery can cause injury or death. Open main disconnect, tag and lockout power supply to the starter before working on the electric motor.

ELECTRIC MOTOR GREASE RECOMMENDATIONS (–30° to 50° C)

MANUFACTURER	TRADE NAME
CHEVRON	SRI #2
SHELL	DOLIUM R
EXXON	UNIREX #2
EXXON	POLYREX

ELECTRIC MOTOR REGREASING INTERVAL

Type of Service	Typical Examples	Rating	Relubrication Interval
Standard	One– or Two–Shift Operation	Up to 150 HP (112 KW)	18 Months
		Above 150 HP (112 KW)	12 Months
Severe	Continuous Operation	Up to 150 HP (112 KW)	9 Months
		Above 150 HP (112 KW)	6 Months
Very Severe	Dirty Locations, High Ambient Temperature	Up to 150 HP (112 KW)	4 Months
		Above 150 HP (112 KW)	2 Months

SECTION 3 STARTING & OPERATING PROCEDURES

PRESTART-UP INSTRUCTIONS – A new unit as received from the factory has been tested and then prepared for shipping only. Do not attempt to operate the unit until checked and serviced as follows:

1. **Compressor Oil** – Check the oil level in the reservoir. Add oil only if oil level gauge reads in the red “ADD OIL” range. Do not mix different type oils. EDM and EDP units are shipped filled with Gardner Denver AEON™ 4000 Lubricating Coolant which is suitable for the first 6000 hours under normal operating conditions. EAQ and EBQ units are shipped filled with Gardner Denver AEON™ 9000 SP Lubricating Coolant which is suitable for the first 8000 hours under normal operating conditions.

REPLACE OIL FILTER EVERY 1000 HOURS.

Initial fill, or filling after a complete draining of the system, may show the oil level in the yellow “EXCESS OIL” range. After start-up, the oil will fall into the green operating range as system components are filled. If necessary, add oil to bring the level to the top of the green range as read when the unit is operating at full load and normal pressure. See FIGURE 5-5, page 38.

During unloaded operation and after shutdown, the system will partially drain back into the oil reservoir and the oil level may read higher than when operating on load. DO NOT DRAIN OIL TO CORRECT; on the next loaded cycle or start, oil will again fill the system and the gauge will indicate the operating level.

2. **Air Filter** – Inspect the air filter to be sure it is clean and tightly assembled. Refer to Section 6, “Air Filter,” page 45, for complete servicing instructions. Be sure the inlet line, if used, is tight and clean.
3. **Coupling** – Check all bolts and cap screws for tightness. See Section 7, page 47.
4. **Piping** – Refer to Section 2, “Installation,” page 8, and make sure piping meets all recommendations.
5. **Electrical** – Check the wiring diagrams furnished with the unit to be sure it is properly wired. See FIGURE 4-13 thru FIGURE 4-15, pages 30 thru 32, for general wiring diagrams and Section 2, page 8 for installation instructions.
6. **Grounding** – Equipment must be properly grounded according to Table 250-95 of the National Electrical Code.

NOTICE

Regular maintenance and replacement at required intervals of the oil filter, air filter and air-oil separator is necessary to achieve maximum service and extended drain intervals of AEON™ 9000 SP synthetic lubricant. Use only genuine Gardner Denver filters designed and specified for this compressor.

WARNING

Failure to properly ground the compressor package could result in controller malfunction.

DANGER

Before removing the oil filler plug, always stop the unit and release air pressure, tag and lockout the power supply to the starter. Failure to release pressure or properly disconnect the power may result in personal injury or death.

WARNING

Operation with incorrect motor rotation can damage equipment and cause oil eruption from the compressor inlet. When checking motor rotation, induce minimum rotation (less than one revolution if possible). Never allow motor to reach full speed.

7. **Rotation** – Check for correct motor rotation using “JOG MODE.” Compressor drive shaft rotation must be clockwise standing facing the compressor coupling.

8. **System Pressure** – Set the controls to the desired load pressure. DO NOT EXCEED THE MAXIMUM OPERATING PRESSURE ON THE COMPRESSOR NAMEPLATE. See Section 4, “Controls and Instruments” for procedure.

 **WARNING**

Operation at excessive discharge air pressure can cause personal injury or damage to equipment. Do not adjust the full discharge air pressure above the maximum stamped on the unit nameplate.

9. **Operating Mode** – Refer to Section 4 for detailed information on the control system.
10. **Enclosure** – Check for damaged panels or doors.

Check all screws and latches for tightness. Be sure doors are closed and latched.

STARTING THE UNIT – Observe the following starting procedures.

Unit Cold – If the unit is a water-cooled heat exchanger model, open any manual water inlet valves wide open. Start the unit by pushing either the “CONSTANT RUN” button or one of the “AUTO” buttons. Since the unit is equipped with a minimum (65 psig, 4.5 Bars) pressure discharge valve, no special procedure to maintain unit reservoir pressure is required.

Unit Hot – No warm-up period is required. If the unit is a water-cooled heat exchanger model, open any manual water inlet valves wide open. Start the unit by pushing either the “CONSTANT RUN” button or one of the “AUTO” buttons.

DAILY CHECK – Refer to Section 8, “Maintenance Schedule,” page 48.

STOPPING THE UNIT – Press “STOP-RESET” button. The oil reservoir will automatically blow down as the motor stops. If the unit is a water-cooled heat exchanger type, close any manual water inlet valves.

SECTION 4 CONTROLS & INSTRUMENTATION

GENERAL DESCRIPTION – The Gardner Denver rotary screw compressor is prewired with all controls, motor, and starter for the voltage and horsepower at the time of ordering. It is necessary only to connect the compressor unit to the correct power supply and to the shop air line (and to the appropriate water supply if water cooled). A standard compressor unit consists of the compressor, oil reservoir, oil cooling system and filter, motor type as specified, NEMA 12 starter / control box, and control components as described below.

AUTO SENTRY® OPERATION

Operation of the “Auto Sentry®” controller is dependent on selection of an operating mode from the controller keypad. Prior to starting, the [STOP/RESET] key must be pressed to place the controller into its READY state (as indicated on the display). Compressor operation may then be started by pressing an operating mode key.

AUTOMATIC is the most commonly selected mode of operation, as it will operate the compressor unit automatically in the most efficient manner for the demand of the air system.

Once operating, the mode may be changed at any time by pressing a key, and the selected mode will be displayed in the lower right corner of the message window. Press the [STOP/RESET] key at any time to stop the compressor under normal conditions.

Detailed instructions for the controller are found in the manual 13–9/10–647.

WARNING

Automatic restarting or electrical shock can cause injury or death. Open, tag and lockout main disconnect and any other circuits before servicing the unit.

CONTROL DEVICES

Controller – This compressor unit features the “AUTO SENTRY®” controller, which integrates all the control functions under microprocessor control. Its functions include safety and shutdown, compressor regulation,

operator control, and advisory/maintenance indicators. The keypad and display provide the operator with a logical and easily operated control of the compressor and indication of its condition. The controller is factory adjusted for the compressor package, but allows tuning for specific applications.

OTHER CONTROL DEVICES

In addition to the electronic controller described in the controller manual 13–9/10–647, the following components are also used to control operation of the compressor unit.

Relief Valve – A pressure relief valve(s) is (are) installed in the final discharge line and set to approximately 120–125% of the unit’s full load operating pressure for protection against over pressure. Periodic checks should be made to ensure its (their) operation.

The relief valve should be tested for proper operation at least once every year. To test the relief valve, raise the system operating pressure to 75% of the relief valve set pressure and manually open the valve with the hand lever. Hold the valve open for a few seconds and allow it to snap shut.

WARNING

When the relief valve opens, a stream of high velocity air is released, resulting in a high noise level and possible discharge of accumulated dirt or other debris. Always wear eye and ear protection and stand clear of the discharge port when testing the relief valve to prevent injury.

CAUTION

Never paint, lubricate or alter a relief valve. Do not plug vent or restrict discharge.

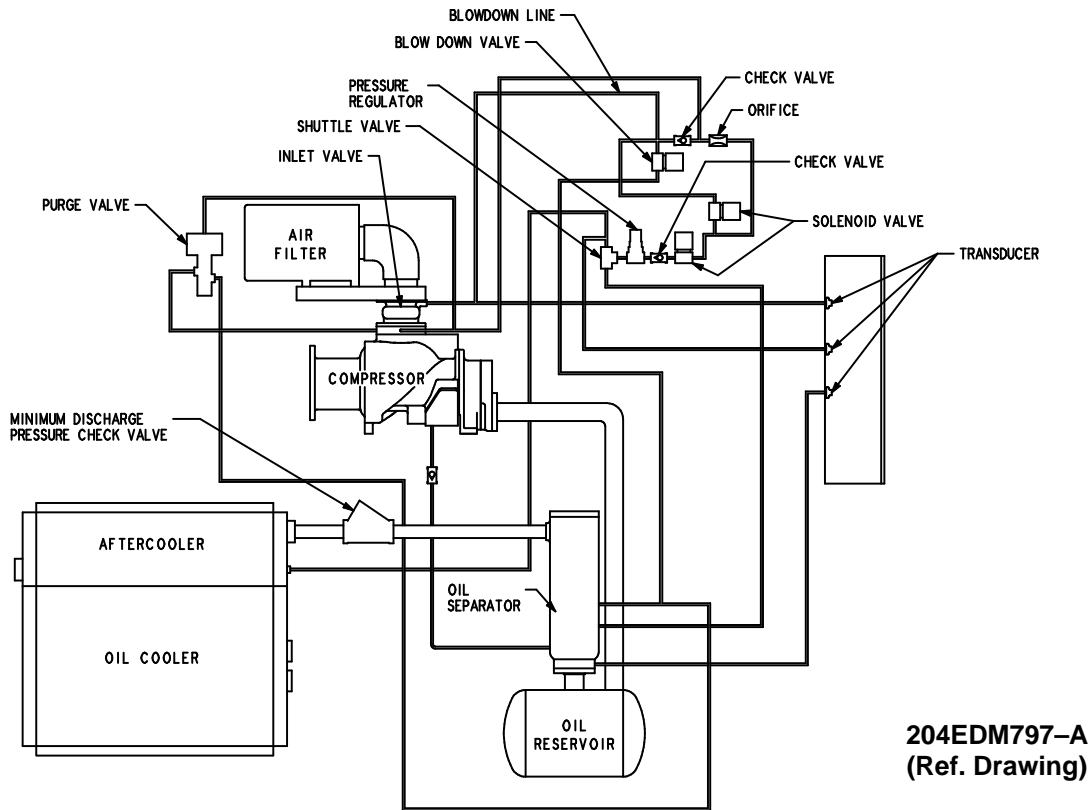

204EDM797-A
(Ref. Drawing)

FIGURE 4-1 – SCHEMATIC TUBING DIAGRAM

WARNING

Operation of unit with improper relief valve setting can result in severe personal injury or machine damage. Insure properly set valves are installed and maintained.

Blowdown Valve (FIGURE 4-2) – This valve normally is used for control functions, but also serves to relieve reservoir pressure following a shutdown. See additional blowdown valve description on page 21.

Oil Level Gauge (FIGURE 1-6, Section 1, page 3) – This gauge is located on the oil reservoir and indicates the oil level.

Minimum Discharge Pressure/Check Valve (FIGURE 4-3, page 20) – An internal spring-loaded minimum pressure valve is used in the final discharge

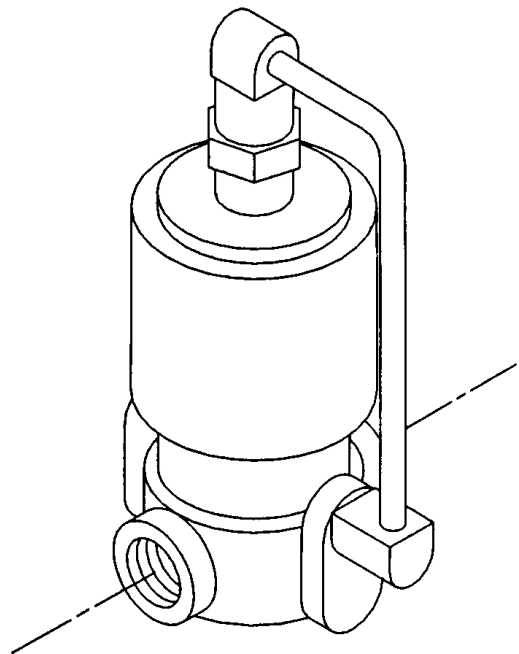

FIGURE 4-2 – BLOWDOWN VALVE

line to provide a positive pressure on the coolant system of the compressor even if the air service valve is fully open to atmospheric pressure. This valve also functions as a check valve to prevent back flow of air from the shop air line when the unit stops, unloads, or is shut down.

The valve incorporates an orifice which, when air is flowing through it, maintains pressure in the oil reservoir. A spring-loaded piston valve senses air pressure on the upstream (reservoir) side of the valve. When the system pressure rises, the spring is overridden and the valve opens to full porting.

The valve does not require maintenance or adjustment. If the valve fails to function, check the valve stem O-ring for sealing, valve orifices for restriction, or valve and valve seat for burrs and dirt.

Inlet Valve (FIGURE 1-4 page 2, and FIGURE 4-4) – The Inlet valve restricts the inlet to control delivery and closes to unload the compressor. At shutdown, the inlet valve closes to prevent the back flow of air.

The inlet valve position is controlled by air pressure in its piston cylinder, which is controlled by the “AUTO SENTRY®” controller through solenoid valves IVC and IVO.

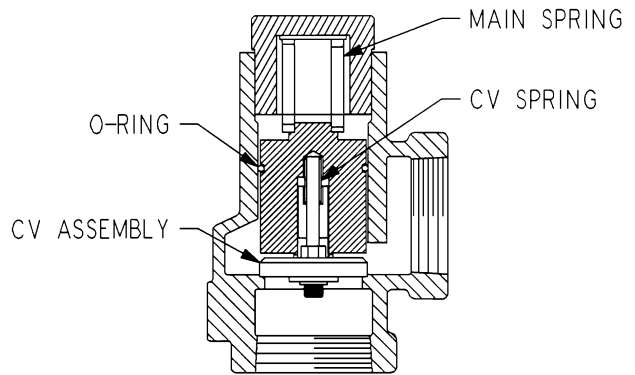
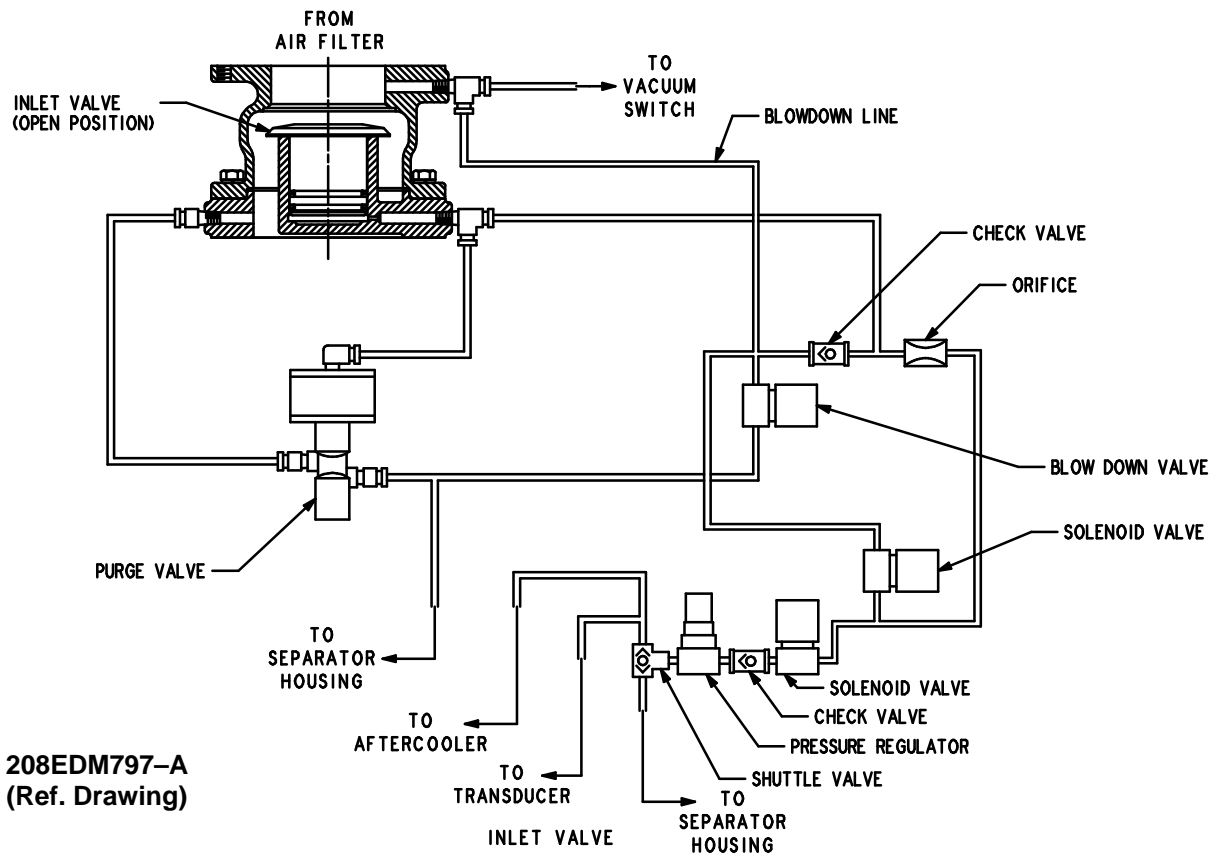

FIGURE 4-3 – MINIMUM DISCHARGE PRESSURE / CHECK VALVE

As pressure to the piston is increased, the valve closes to restrict air flow and compressor delivery.

Solenoid Valves IVC and IVO – These valves control position of the inlet valve in response to signals from the “AUTO SENTRY®” controller. With both valves de-energized, the normally open IVC valve allows con-



208EDM797-A
(Ref. Drawing)

FIGURE 4-4 – INLET VALVE

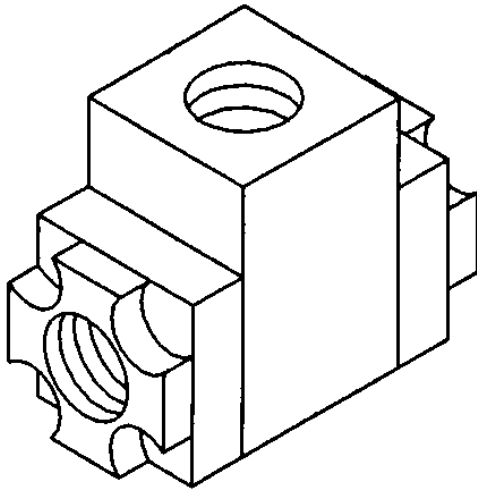

FIGURE 4-5 – SHUTTLE VALVE

control pressure to the inlet piston to close the valve. If IVC only is energized, the inlet valve is held in its current position. If both valves are energized, control pressure is relieved from the inlet piston to allow the valve to open.

Pressure Regulator – The pressure regulator is used to supply a constant and low control pressure to prevent damage to the inlet valve from “slamming.” The regulator should be set for 25–30 psig.

Shuttle Valve (FIGURE 4-5) – Also known as a double check valve, the shuttle valve is a device which will take two (2) supply signals and allow the one with the highest pressure to pass through. The shuttle valve is used to provide control air pressure from either the reservoir or plant air system, as required during different operating conditions.

Blowdown Valve (FIGURE 4-2, page 19) – The blowdown valve is a two-way solenoid valve which is piped into the oil reservoir outlet ahead of the minimum pressure valve. When the solenoid is de-energized, the valve opens and the coolant system is blown down. When the solenoid is energized, the valve closes to allow the coolant system to pressurize. A control air check valve is provided to ensure that the inlet valve is closed during blowdown.

System Pressure Transducer – This transducer is connected after the minimum pressure valve. It converts the pressure in the plant air system into an electrical signal for use by the “AUTO SENTRY®” controller for modulation and control.

Reservoir Pressure Transducer – This transducer is connected to the coolant system. Its signal is used

to prevent loaded starts, monitor coolant pressure, and monitor the condition of the separator filter.

Air Filter Vacuum Switch – This switch is used to monitor air filter condition and alert the user if the filter requires service or replacement.

Discharge Thermistor – This sensor is located directly in the compressor discharge. Its signal is used to monitor compressor temperature and shut down the compressor if a coolant problem is detected.

Reservoir Thermistor – This sensor is located in the unit separator housing. Its signal is used for gauging and temperature shutdowns.

Optional Switches – The “AUTO SENTRY®” controller has one additional input available for dealer or user installed optional shutdown switches. If the contact is opened, the compressor will be shut down, and will display “HIGH VIBRATION.”

Emergency Stop Push-Button – This is a maintained push-button, and removes power from the controller outputs regardless of controller status. It is located on the upper section of the panel, next to the keypad. This should be used for emergency purposes only – use the keypad [STOP/RESET] for normal controlled stopping.

⚠ WARNING

Automatic restarting or electrical shock can cause injury or death. Open, tag and lockout main disconnect and any other circuits before servicing the unit.

Control Transformer – This changes the incoming power voltage to 110–120 volts for use by all unit control devices. Two primary fuses and one secondary fuse are provided. Refer to adjacent labeling for replacement information.

Terminal Strip – This provides connections for all 110–120 volt devices not contained within the enclosure.

Fan Starter – The starter is used to provide control and overload protection for the fan. Overload heaters should be selected and adjusted based on the motor nameplate amps and the instructions located inside the cover of the electrical enclosure.

Main Starter – This starter is used to provide control and overload protection for the main drive motor. Full voltage starters employ a single contactor, overload heaters should be selected and adjusted based on the motor nameplate amps and the instructions located inside the cover of the enclosure. Wye–delta starters employ three contactors which are controlled sequentially to provide low current starting. For wye–delta starters, the motor nameplate amps must be first multiplied by 0.577 before using the heater table.

Purge Air Valve – The purge valve is a normally closed two–way air actuated valve that admits purge air from the final discharge manifold to the compressor to counteract the oil knock that occurs in oil–flooded rotary screw compressors when they are completely unloaded with pressure in the oil reservoir. This valve is controlled by the same control pressure which controls the inlet valve.

COMPRESSOR CAPACITY CONTROL – EAQ UNITS ONLY

The capacity of the compressor is controlled by the action of the Turn Valve and the Compressor Inlet Valve.

The turn valve controls compressor delivery to match demands of 40% to 100% of the compressor’s maximum capacity. The inlet valve throttles to control compressor delivery to match demands of 0% to 40% of the compressors maximum capacity.

Example with normal setting of 100 PSIG:

Compressor Delivery	Inlet Valve	Turn Valve	Discharge Manifold Pressure
Full Capacity	Open	Closed	100
70% Capacity	Open	50% Open	100
40% Capacity	Open	Full Open	100
30% Capacity	Closing	Full Open	103
20% Capacity	Closing	Full Open	103
0% Capacity	Closed	Full Open	103

Solenoid Valves TVC and TVO – EAQ Units Only– These valves control position of the turn valve in response to signals from the “AUTO SENTRY®” controller. With both valves de–energized, equal pressure is supplied to both sides of the actuator to hold it in its present position. If TVC only is energized, the right side of the turn valve actuator is exhausted to the compressor inlet cavity, causing the turn valve to move towards the full load position. If TVO only is energized, the left side of the turn valve actuator is exhausted to the compressor inlet cavity, causing the turn valve to move towards the unload position. See “Control System Operation” in this section for a description of how the turn valve components respond during operation.

Turn Valve – EAQ Units Only The turn valve is a helical valve which, when rotated, opens and closes a series

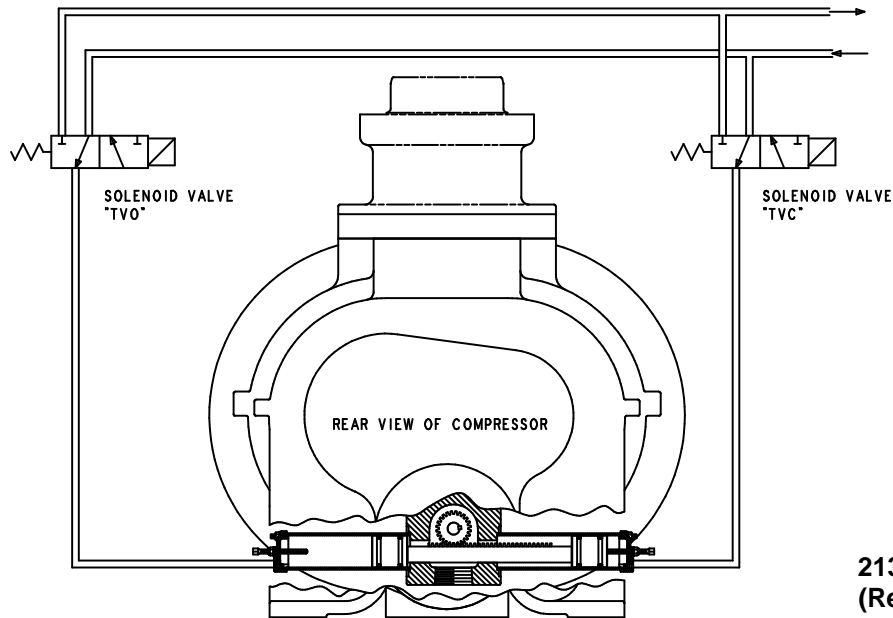

213ECM797–A
(Ref. Drawing)

FIGURE 4–6 – TURN VALVE – EAQ UNITS ONLY

of ports cast into the compressor cylinder. When these ports are open, they direct some of the air which would otherwise be compressed back to the inlet, reducing both capacity and power consumption.

Turn Valve Actuator – EAQ Units Only (FIGURE 4–6, page 22) The turn valve actuator is a rotary rack and pinion device which positions the turn valve according to system demand. Filtered oil from the compressor sump is directed to the outboard end of the two actuating cylinders to move the rack and rotate the valve. Lo-

cated on the end of the cylinders are adjusting screws which limit the travel of the actuator. When looking at the rear of the compressor, the adjusting screw on the right on the compressor adjusts the fully closed (full load) position of the valve. The full load position of the actuator may be checked by removing the adjusting screw at the unloaded end of the actuator (left side of the compressor) and using a rod to push the pistons to the full load position. The rod must be clean and free of burs and scale. Take care not to scrape the cylinder walls when moving the piston.

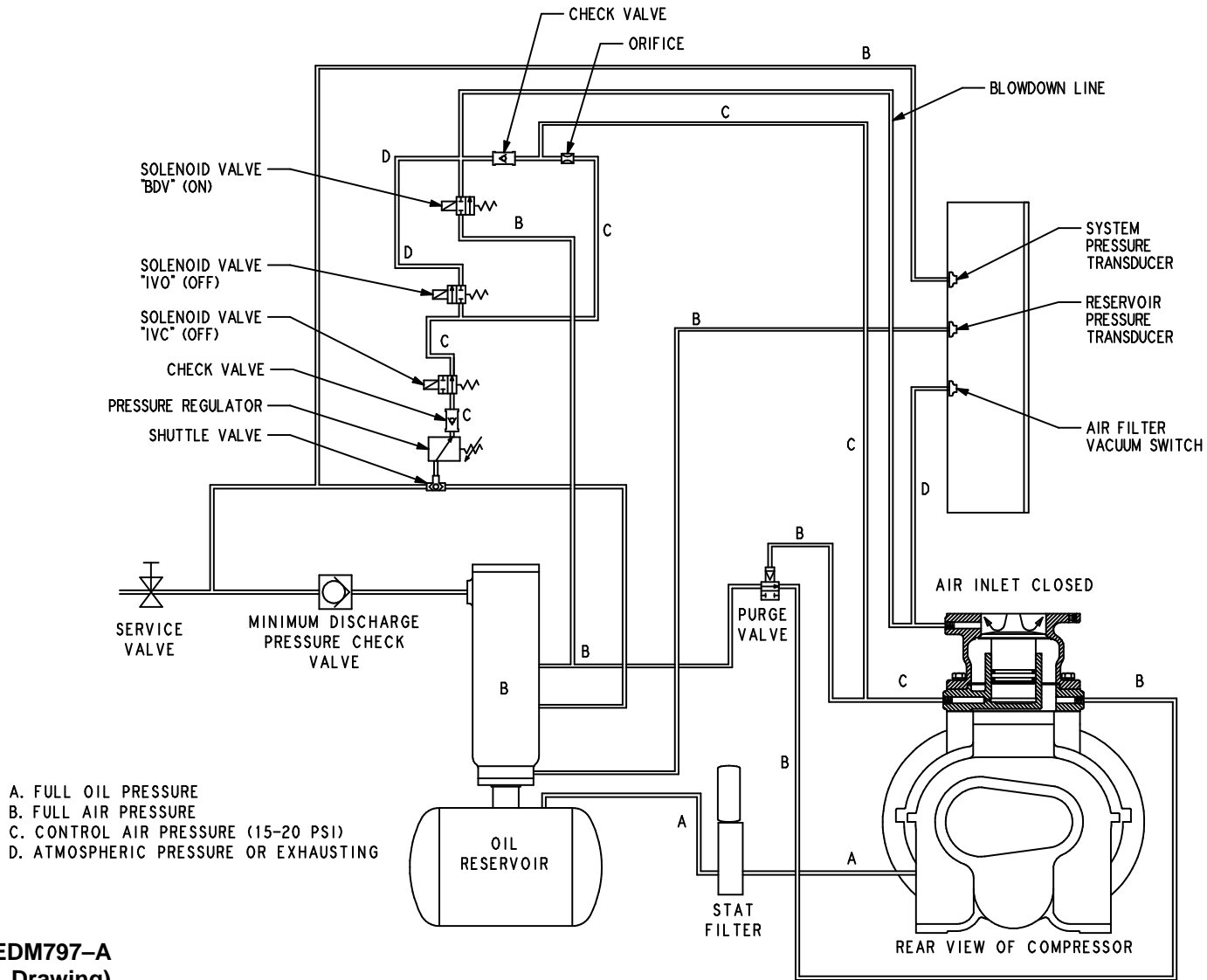

FIGURE 4-7 - CONTROL SCHEMATIC - COMPRESSOR UNLOADED - CONSTANT SPEED MODE
EBQ, EDM & EDP UNITS ONLY

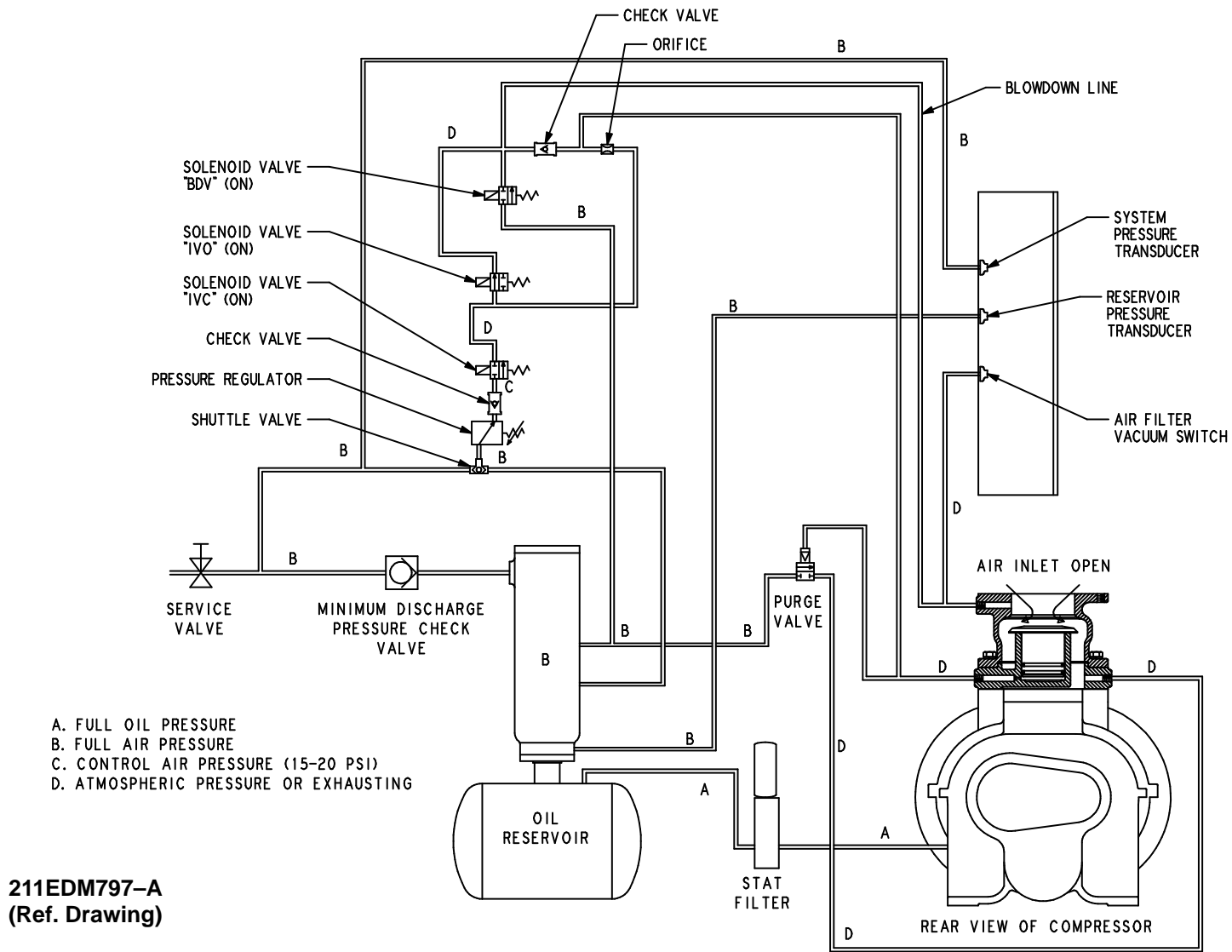
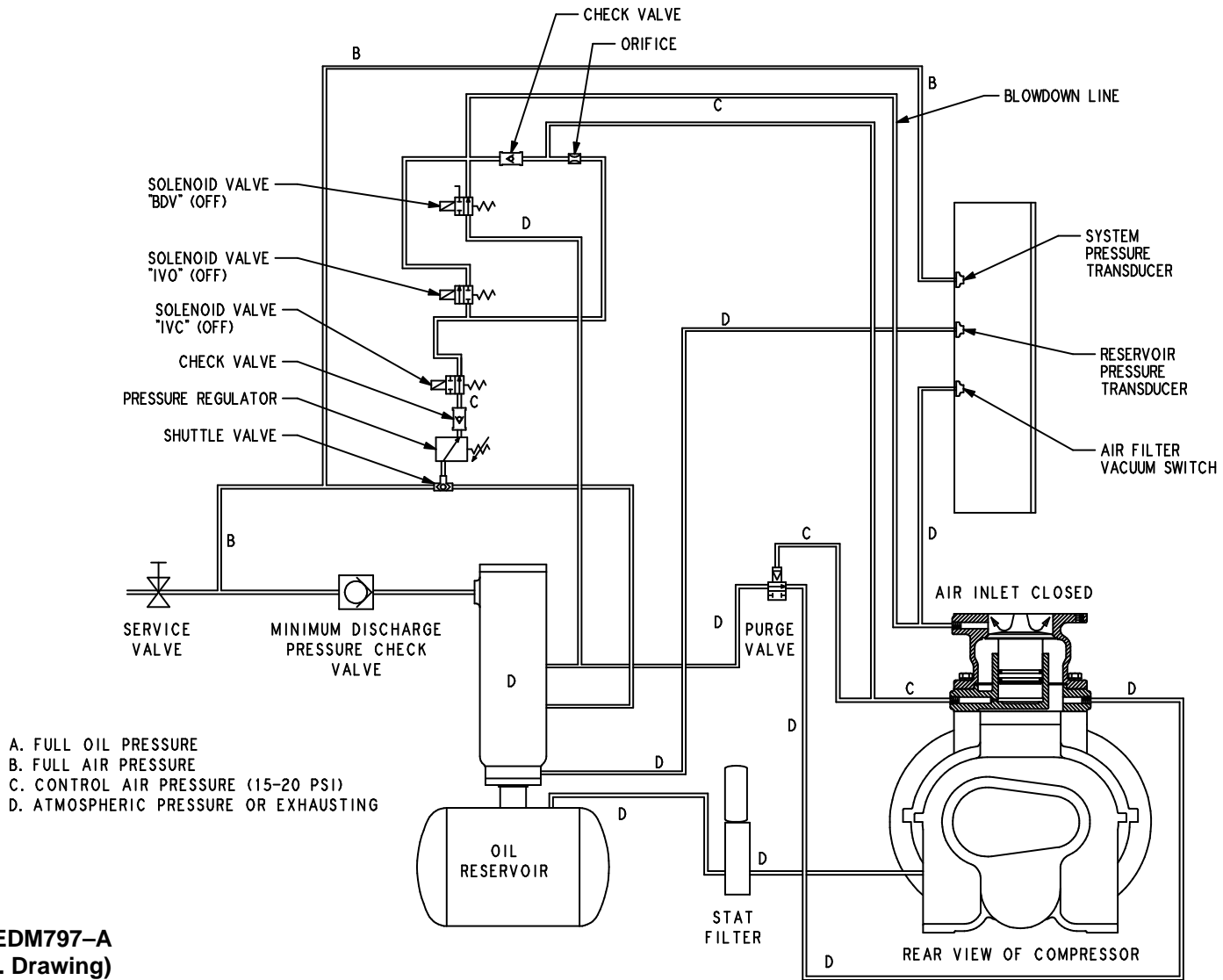

FIGURE 4-8 - CONTROL SCHEMATIC - COMPRESSOR AT FULL LOAD - CONSTANT SPEED MODE
 EBQ, EDM & EDP UNITS ONLY



213EDM797-A
(Ref. Drawing)

FIGURE 4-9 - CONTROL SCHEMATIC - COMPRESSOR UNLOADED - LOW DEMAND MODE
EBQ, EDM & EDP UNITS ONLY

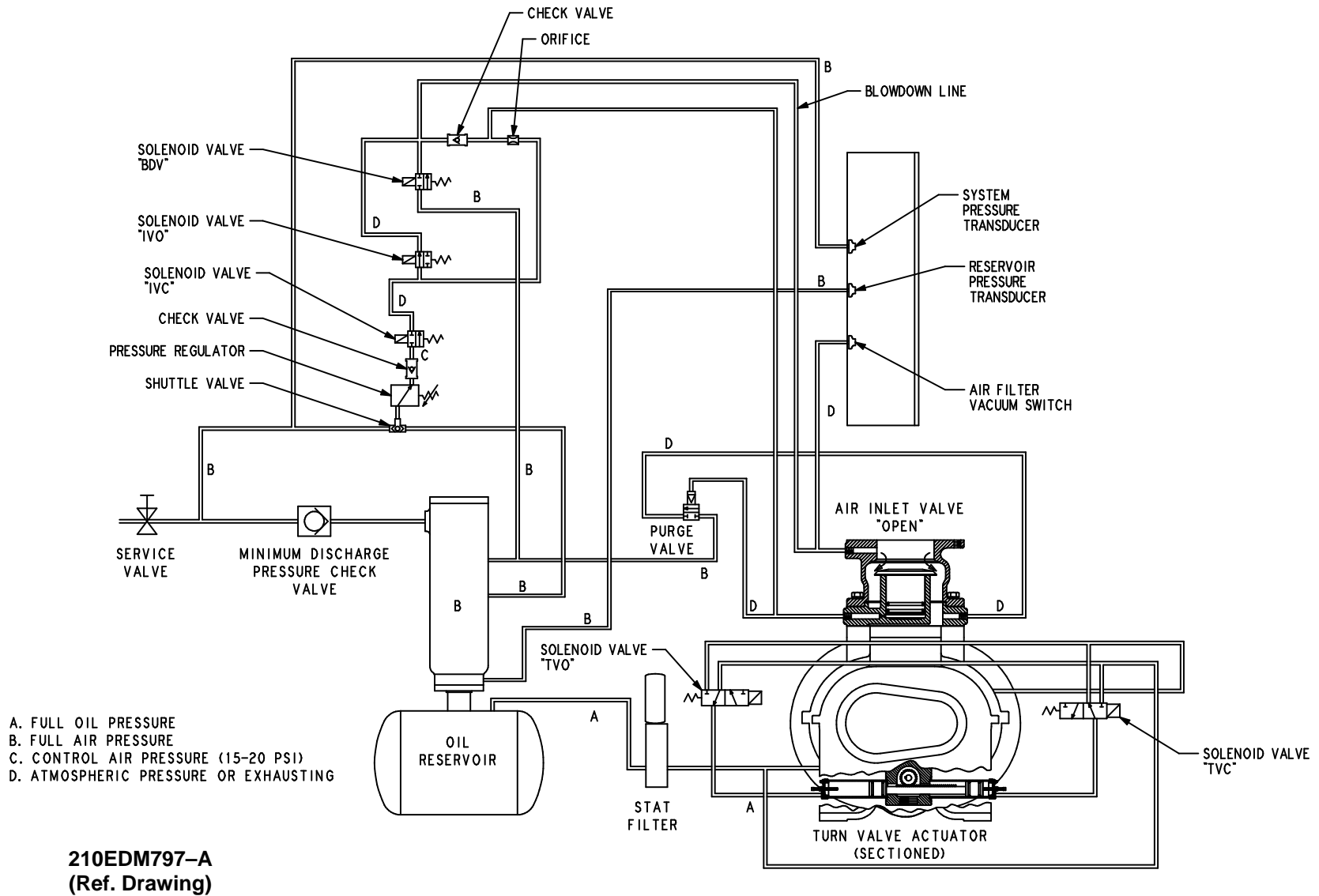

FIGURE 4-10 - CONTROL SCHEMATIC - COMPRESSOR AT FULL LOAD
 EQ UNITS ONLY

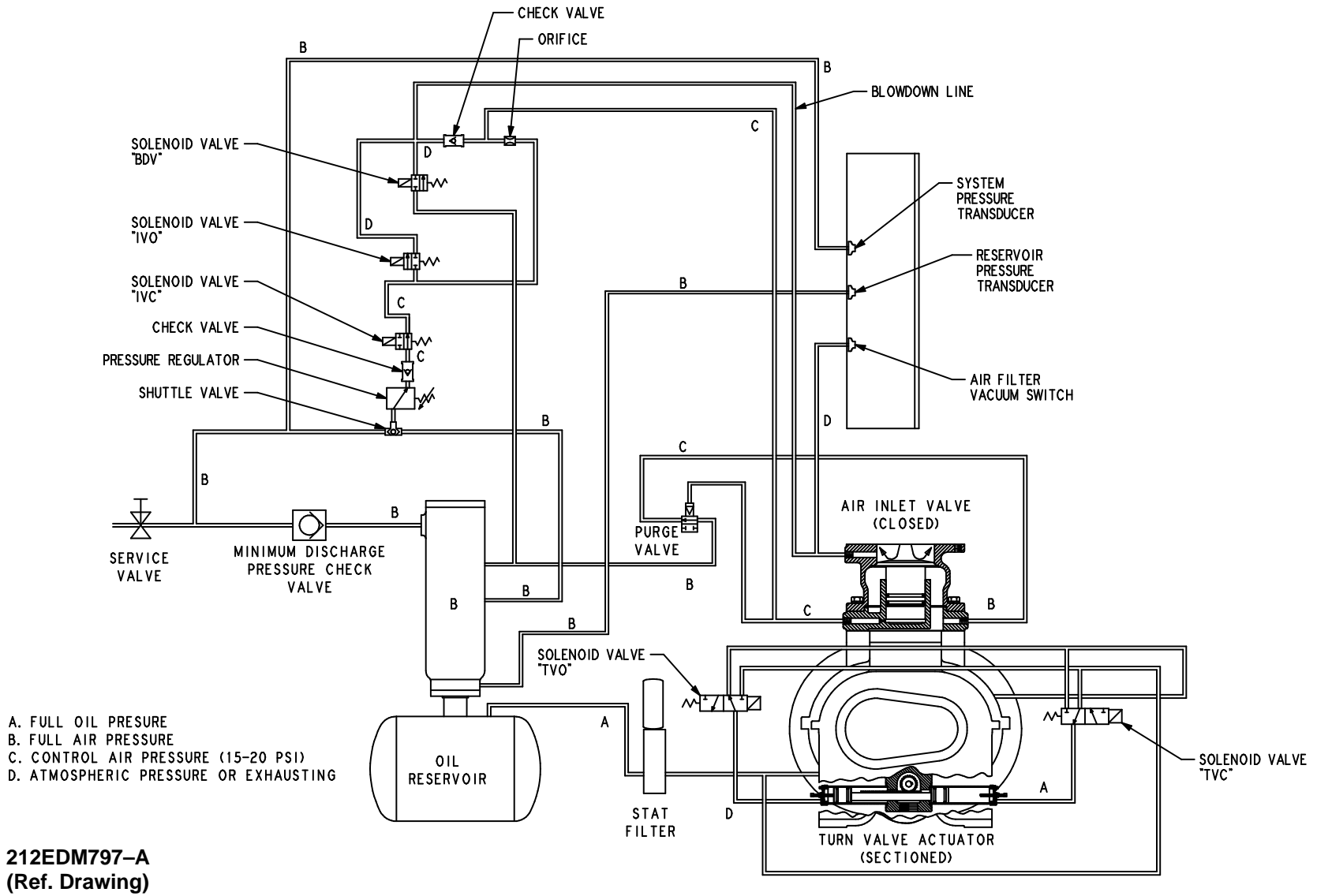

FIGURE 4-11 - CONTROL SCHEMATIC - COMPRESSOR FULLY UNLOADED - LOW DEMAND MODE SWITCH OFF
 EAQ UNITS ONLY

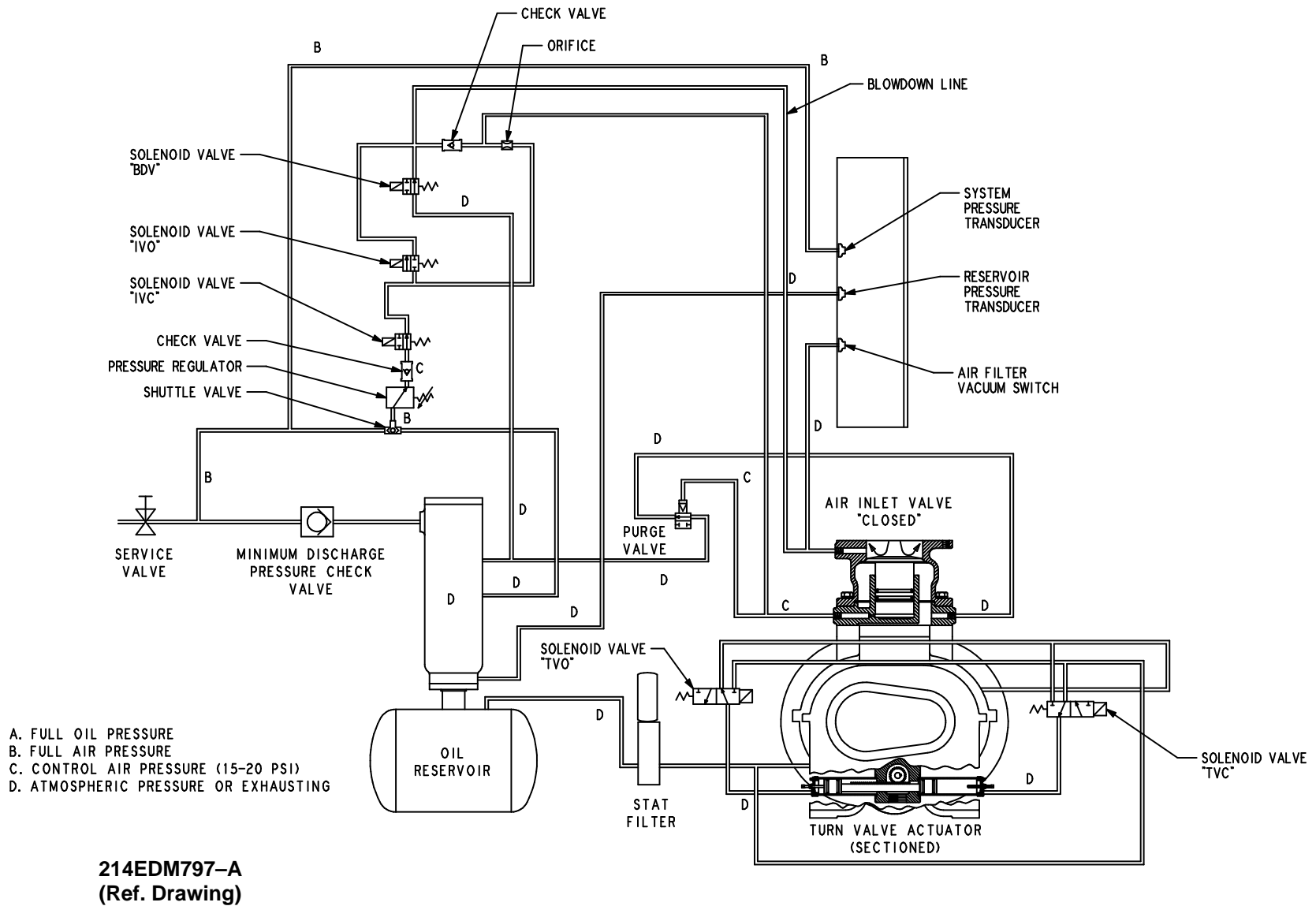

FIGURE 4-12 - CONTROL SCHEMATIC - COMPRESSOR FULLY LOADED - LOW DEMAND MODE SWITCH ON
 EAQ UNITS ONLY

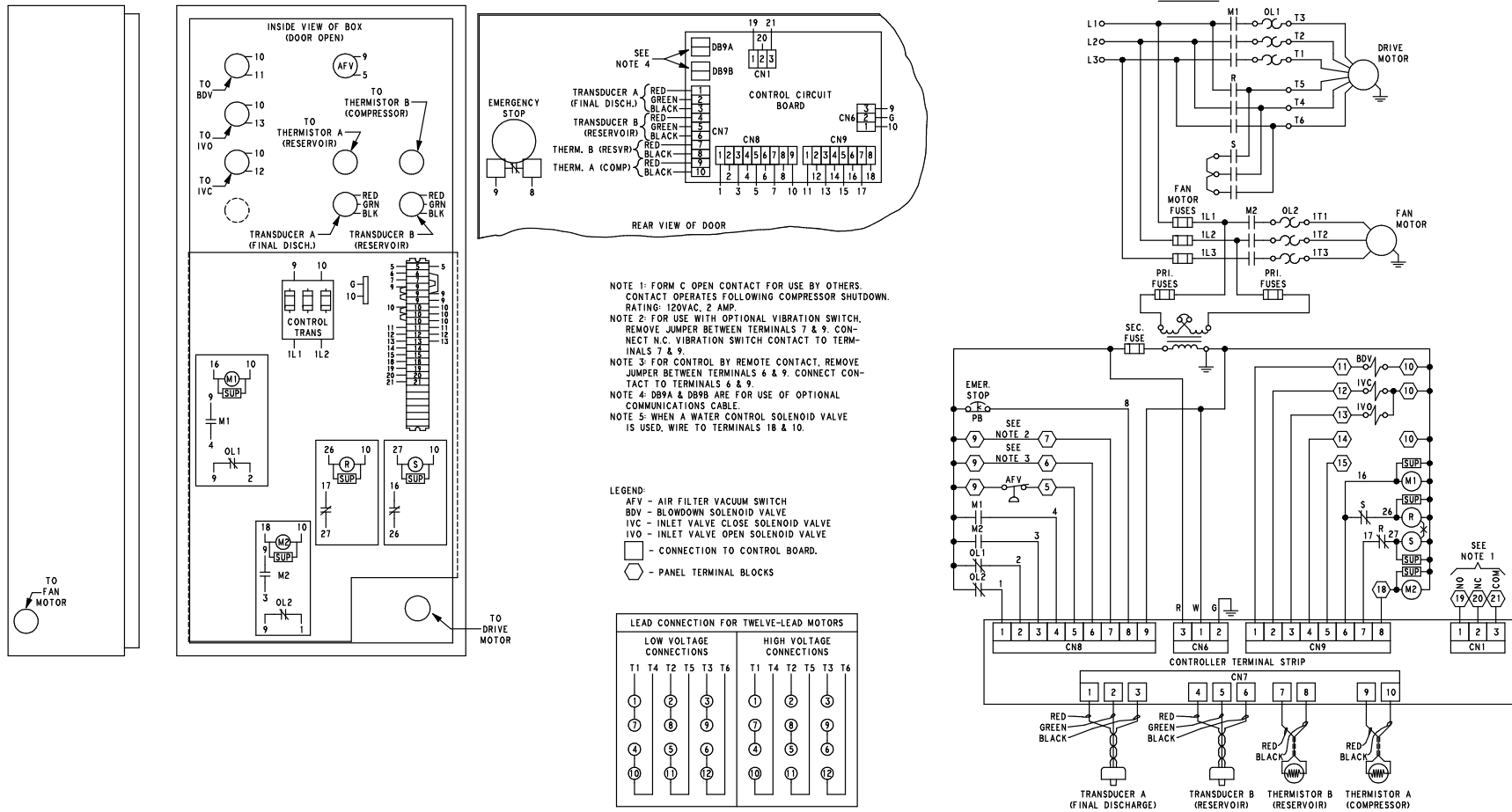

FIGURE 4-13 - WIRING DIAGRAM - 206EDM546 (WYE-DELTA - EBQ UNITS ONLY)

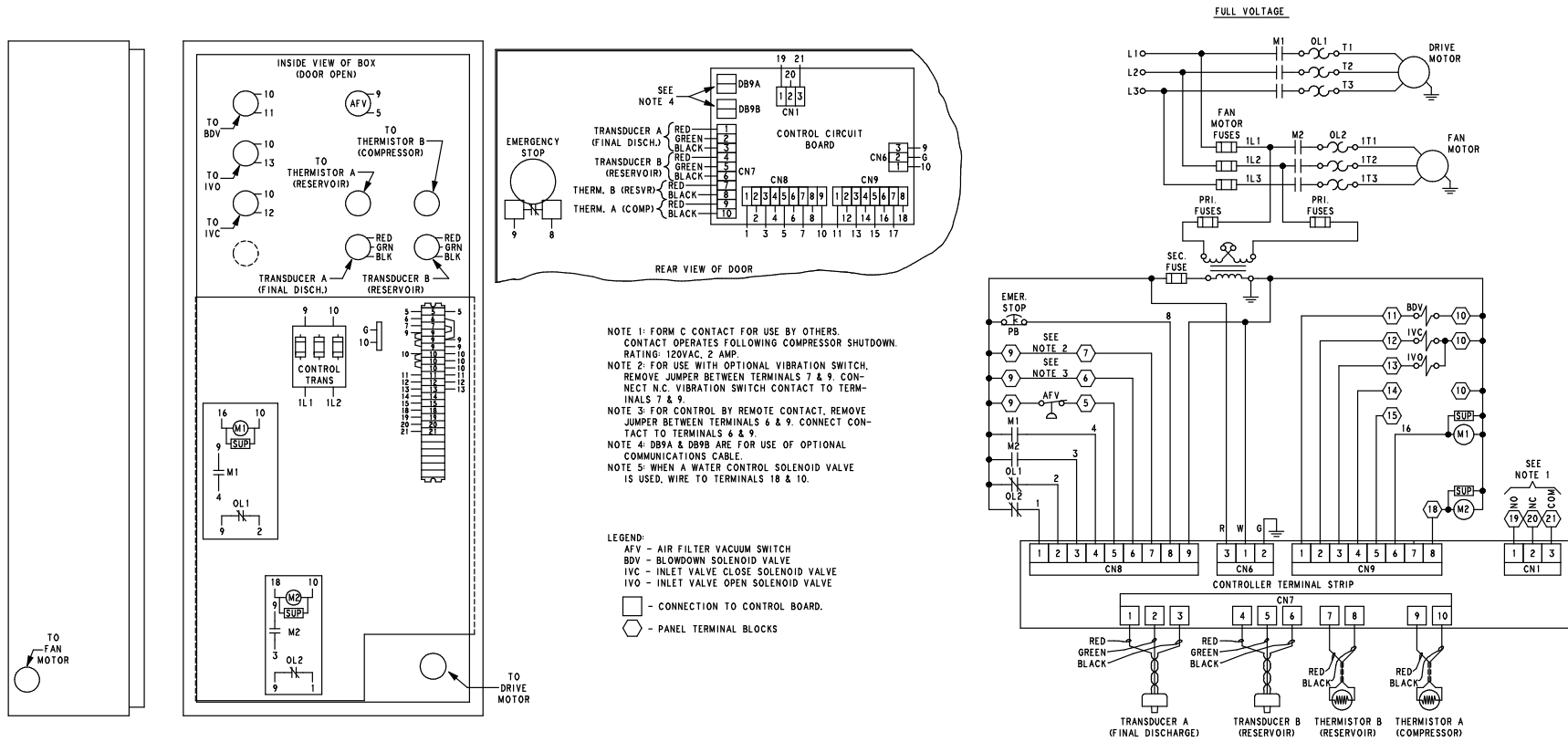
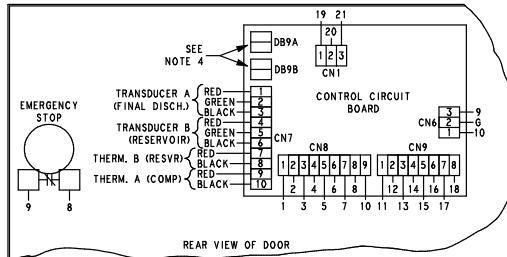
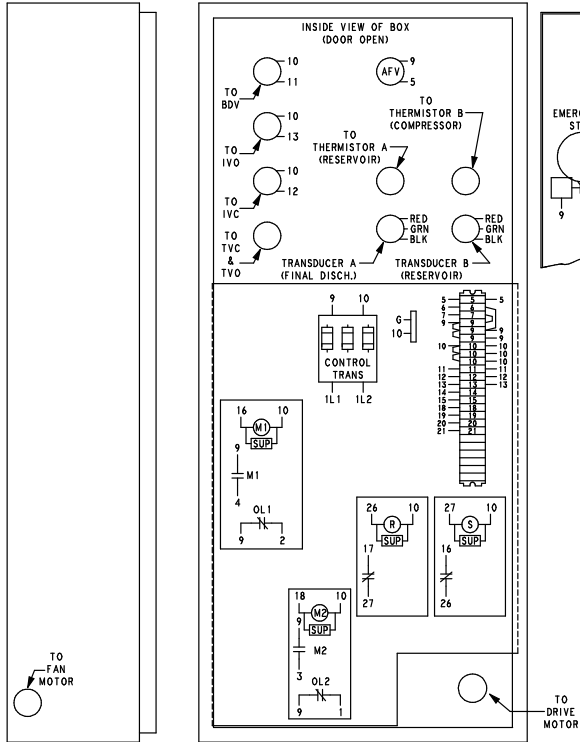

FIGURE 4-14 - WIRING DIAGRAM - 207EDM546 (FULL VOLTAGE - EDM, EDP & EBQ UNITS)



NOTE 1: FORM C OPEN CONTACT FOR USE BY OTHERS. CONTACT OPERATES FOLLOWING COMPRESSOR SHUTDOWN. RATING: 120VAC, 2 AMP.

NOTE 2: FOR USE WITH OPTIONAL VIBRATION SWITCH. REMOVE JUMPER BETWEEN TERMINALS 7 & 9. CONNECT N.C. VIBRATION SWITCH CONTACT TO TERMINALS 7 & 9.

NOTE 3: FOR CONTROL BY REMOTE CONTACT. REMOVE JUMPER BETWEEN TERMINALS 6 & 9. CONNECT CONTACT TO TERMINALS 6 & 9.

NOTE 4: DB9A & DB9B ARE FOR USE OF OPTIONAL COMMUNICATIONS CABLE.

NOTE 5: WHEN A WATER CONTROL SOLENOID VALVE IS USED, WIRE TO TERMINALS 18 & 10.

LEGEND:

AFV - AIR FILTER VACUUM SWITCH

BDV - BLOWDOWN SOLENOID VALVE

IVC - INLET VALVE CLOSE SOLENOID VALVE

IVO - INLET VALVE OPEN SOLENOID VALVE

□ - CONNECTION TO CONTROL BOARD.

○ - PANEL TERMINAL BLOCKS

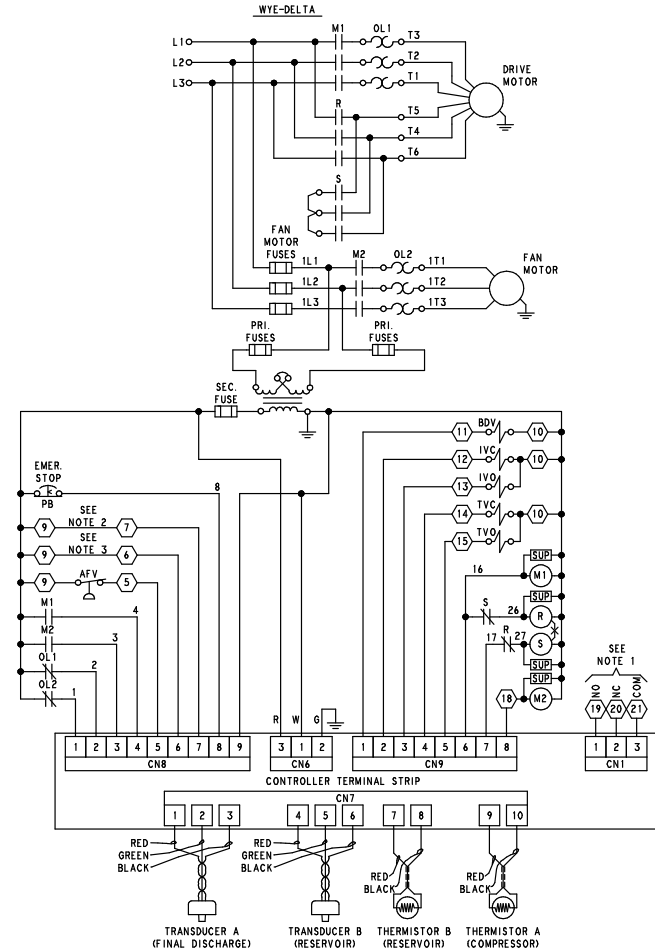
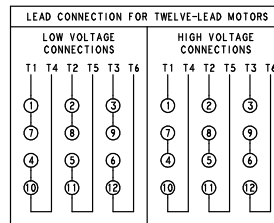

FIGURE 4-15 - WIRING DIAGRAM - 202EAQ546 (WYE-DELTA - EAQ UNITS ONLY)

SECTION 5 LUBRICATION OIL COOLER, OIL FILTER & SEPARATOR

COMPRESSOR OIL SYSTEM (FIGURE 5–1, page 34) cools the compressor, lubricates moving parts and seals internal clearances in the compression chamber.

The oil inlet line is connected at the bottom of the oil reservoir. Air pressure in the oil reservoir forces oil through the oil cooler, thermostatic mixing valve, oil filter and into the compressor main oil gallery.

The oil passes through internal passages for lubrication, cooling and sealing. The air–oil mixture is then discharged to the oil reservoir where a large part of the entrained oil drops out of the air stream; the air then passes through the final oil separator where most of the remaining oil is removed. The separated oil is returned to the compressor and the air passes to the final discharge line.

RECOMMENDED LUBRICANT – Gardner Denver compressors are factory filled with AEON lubricants. These lubricants are formulated to the highest quality standards and are factory authorized, tested and approved for use in rotary screw compressors. AEON lubricants are available through your authorized Gardner Denver compressor distributor.

OIL SPECIFICATIONS: EDM and EDP – The factory fill compressor lubricant is Gardner Denver AEON™ 4000 lubricating coolant which can be used for year–round operation, except as noted in the “High Temperature Operation” paragraph below and the “Installation for Cold Weather Operations, page 10.

AEON™ 4000 lubricating coolant is a superior petroleum base lubricant formulated and containing additives for use in Gardner Denver compressors. A lubricant analysis program for a periodic check of lubricant quality and remaining life can maximize the change interval.

OIL SPECIFICATIONS: EAQ and EBQ (Domestic and International) – The factory fill compressor lubricant is Gardner Denver AEON™ 9000 SP lubricating coolant which can be used for year–round operation. AEON™ 9000 SP is a synthetic, extended life lubricant which can extend lubricant change intervals up to 4 times that of a petroleum based lubricant. A lubricant analysis program for a periodic check of lubricant quality and remaining life can maximize the change interval.

CAUTION

Use of improper lubricants will cause damage to equipment. Do not mix different types of lubricants or use inferior lubricants..

CAUTION

Improper equipment maintenance with use of synthetic lubricants will damage equipment. Oil filter and oil separator change intervals remain the same as for AEON™ 4000 — See Maintenance Schedule, page 48.

HIGH TEMPERATURE OPERATION – Gardner Denver AEON 9000 SP lubricating coolant will operate at a sustained discharge temperature up to 210°F (99°C) when unusually high ambient air temperature is encountered.

DANGER

Air/oil under pressure will cause severe personal injury or death. Shut down compressor, relieve system of all pressure, disconnect, tag and lockout power supply to the starter before removing valves, caps, plugs, fittings, bolts, and filters.

WARNING

High temperature operation can cause damage to equipment or personal injury. Do not repeatedly restart the unit after high temperature stops operation. Find and correct the malfunction before resuming operation.

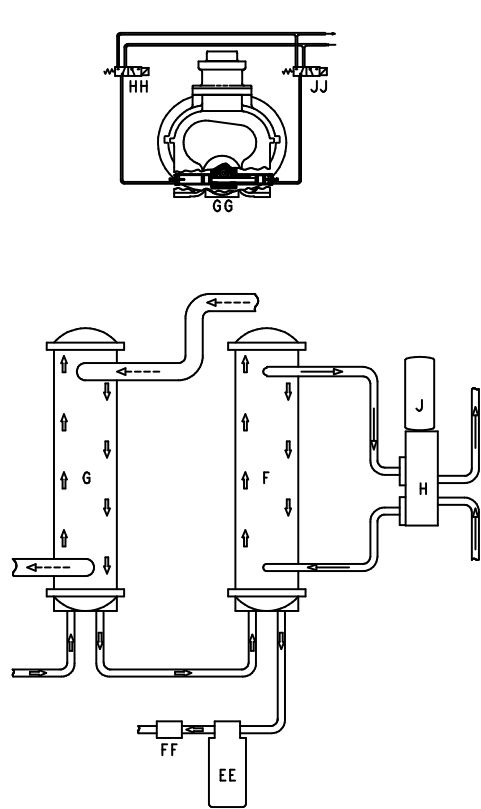

- | | |
|---|----------------------------------|
| A-MOTOR | S-PNEUMATIC BLOW DOWN VALVE |
| B-COMPRESSOR | V-SHUTTLE VALVE |
| C-AIR FILTER | W-PRESSURE REGULATOR |
| D-OIL RESERVOIR | X-SOLENOID VALVE "IVC" |
| E-OIL SEPARATOR | Y-SOLENOID VALVE "IVO" |
| F-OIL COOLER | Z-ORIFICE |
| G-AFTERCOOLER | AA-AIR FILTER VACUUM SWITCH |
| H-STATFILTER | BB-SYSTEM PRESSURE TRANSDUCER |
| J-OIL FILTER ELEMENT | CC-DISCHARGE PRESSURE TRANSDUCER |
| K-SEPARATOR TO CYLINDER
OIL RETURN LINE | DD-FAN AND MOTOR |
| L-CHECK VALVE | EE-WATER FLOW CONTROL VALVE |
| M-PRESSURE RELIEF VALVE | FF-MAGNETIC WATER SHUTOFF VALVE |
| N-MINIMUM DISCHARGE
PRESSURE CHECK VALVE | GG-TURN VALVE ACTUATOR |
| R-PURGE AIR VALVE | HH-SOLENOID VALVE "TVO" |
| | JJ-SOLENOID VALVE "TVC" |
| | KK-BLOWDOWN LINE |

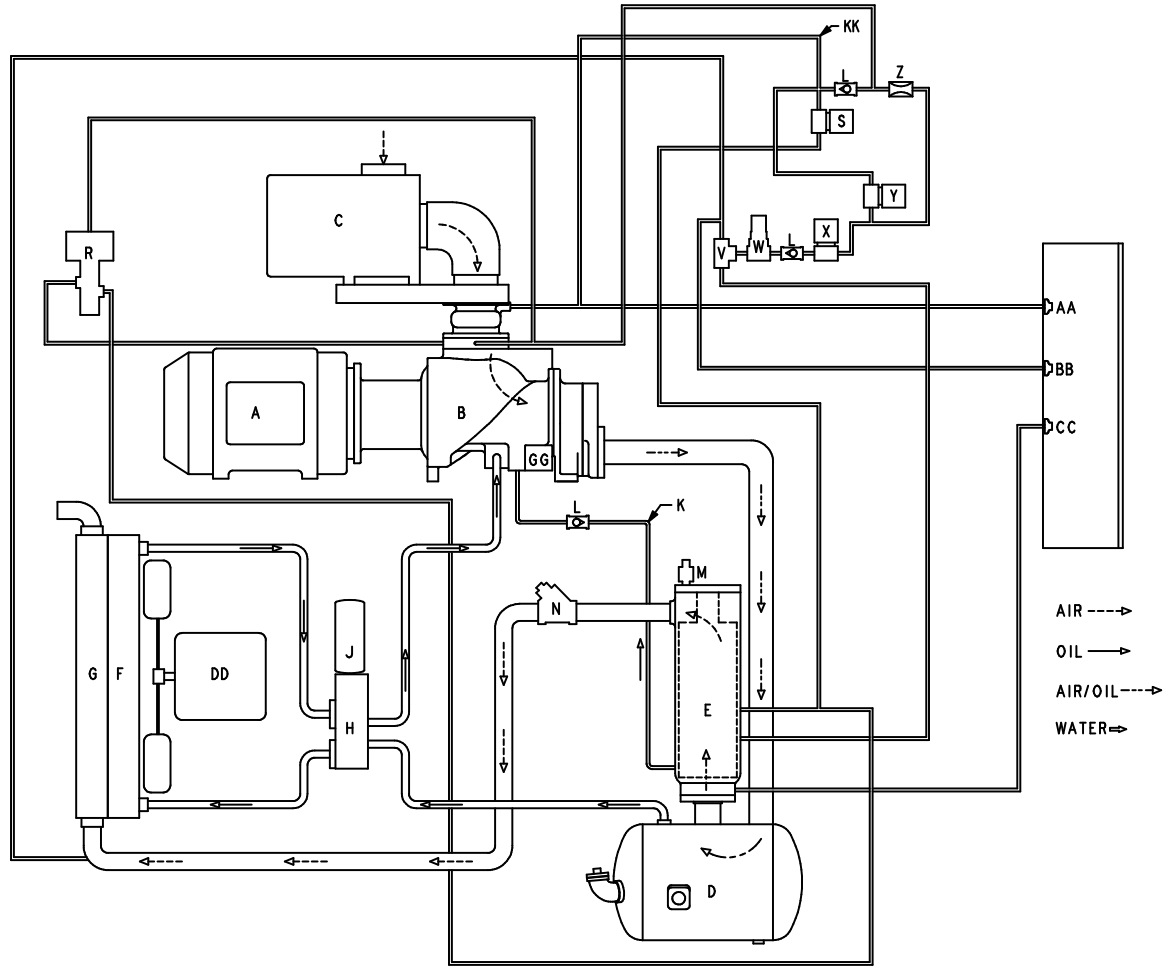

203EDM797-A
(Ref. Drawing)

FIGURE 5-1 - FLOW DIAGRAM

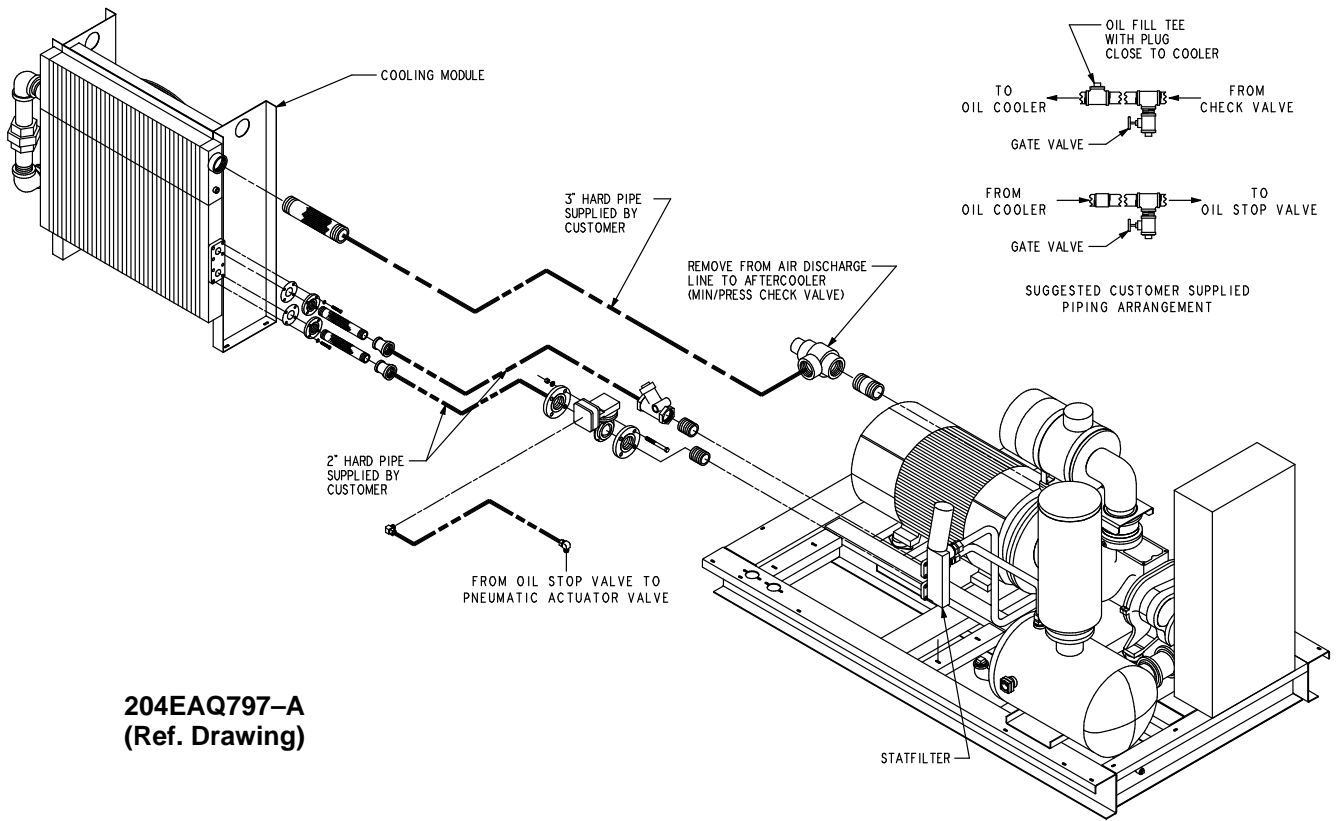

204EAQ797-A
(Ref. Drawing)

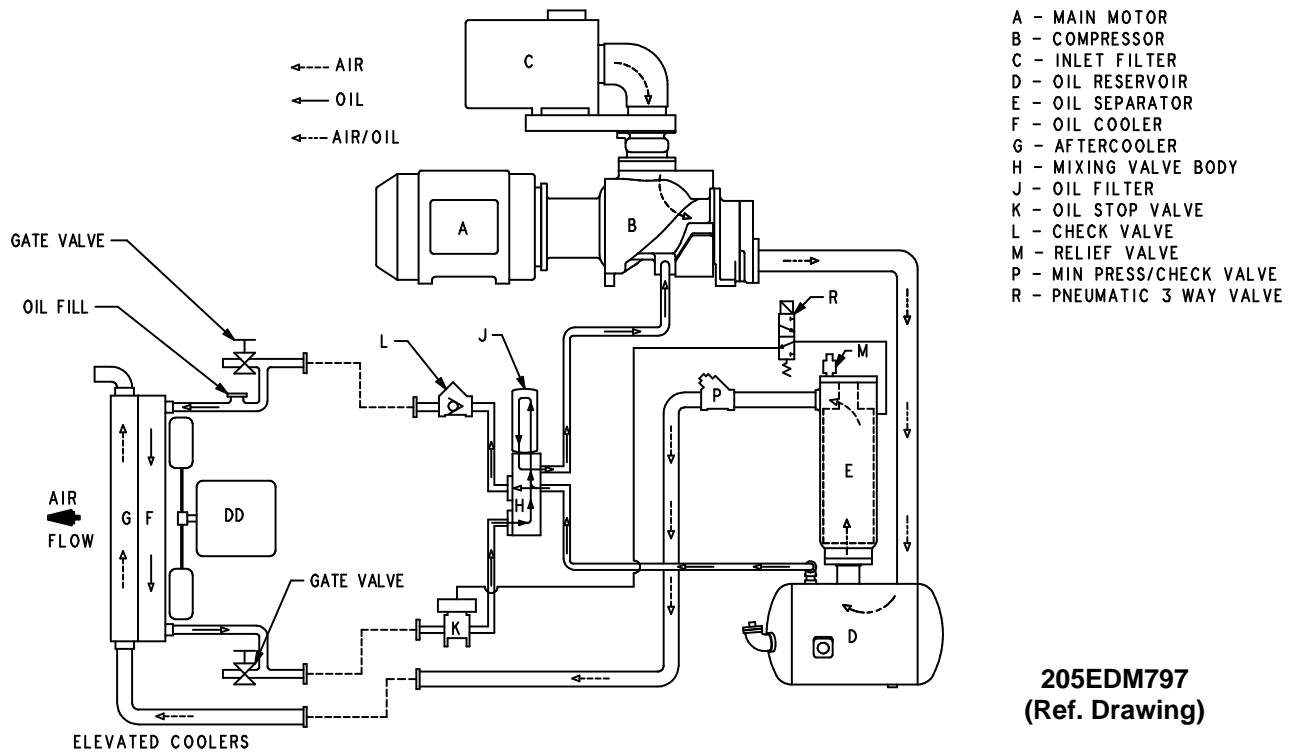

205EDM797
(Ref. Drawing)

FIGURE 5-2 - OIL FLOW DIAGRAM - REMOTE OVERHEAD MOUNTED

WARNING

All materials used in Gardner Denver® compressor units are compatible with AEON™ 9000 SP Lubricating Coolant. Use caution when selecting downstream components such as air line lubricating bowls, gaskets and valve trim.

AEON™ 9000 SP Synthetic Lubricant is not compatible with low nitrile Buna N or acrylic paints. AEON™ 9000 SP is compatible with most air system downstream components.

Material Safety Data Sheets (MSDS) are available for all AEON lubricants from your authorized Gardner Denver distributor or by calling 217-222-5400.

REMOTE MOUNTED ELEVATED COOLER ASSEMBLY PROCEDURE – The Compressor package will be built and tested with the coolers mounted on the package. On enclosed units, the fan motor will be disconnected after test and the vent fan motor connected in its place. The vent fan will be mounted in the enclosure. A contactor (starter) will be shipped loose and remote mounted with the cooler by others upon start-up at the job site. The control box will be wired for remote elevated coolers at the factory.

NOTICE

All requirements of local codes should be followed.

When connecting pipe fittings to the cooler, support the threaded coupling with a pipe wrench when tightening the connection. Use silicone sealant on all steel to aluminum threaded connections. All piping should be firmly supported to avoid strain on the cooler manifold and connections. Flexible connections should be installed in all interconnecting piping, adjacent to the cooler, to avoid transmitting piping weight or vibrations to the cooler elements. Before beginning installations, check to be sure that no debris or foreign matter remains in the couplings or cooler bodies. Be certain interconnecting piping is clean to avoid clogging the cooler passages.

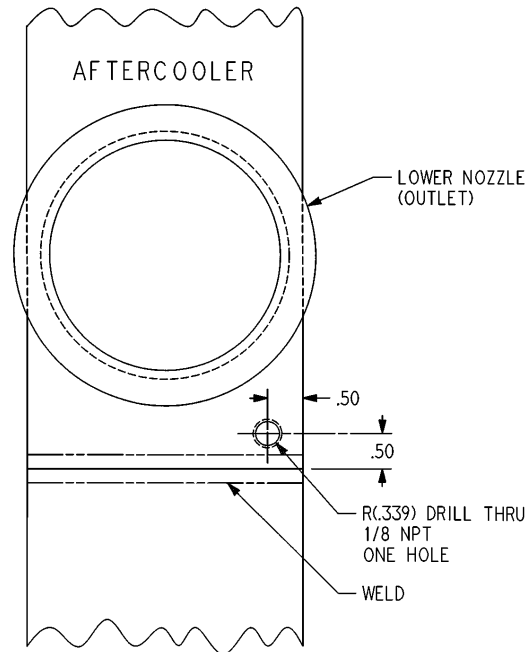

FIGURE 5-3 – COOLER DRAIN DETAIL

AFTERCOOLER PIPING – At shutdown of the system, all units should be drained completely of condensate if there is any possibility of freezing or corrosion damage. To help remove the condensate, the cooler may be tapped per FIGURE 5-3 and a drain cock installed. After opening the drain cock, blow air into the cooler from a connection on the opposite side of the cooler. At the same time the connection on the drain side of the cooler should be plugged. The drain cock should be left open until the machines are ready for start-up.

WARNING

Failure to remove condensate from an idle cooler in freezing temperatures will cause permanent cooler damage. Drain condensate after system shutdown. It is the owner/operator's responsibility to ensure that condensate has been drained and cooler dried out to prevent cooler damage.

HEAT EXCHANGER (OIL) PIPING – All remote elevated cooler applications must be sent through Engineering for approval and for recommending pipe size. When the cooling module is removed from the pack-

age, the thermal mixing valve (H) remains on the package. Control group part number 200ECM4002 will be mounted on package at the factory. This group controls the oil stop valve as well as not allowing machine to run blowdown. See FIGURE 5–2, page 35.

NOTICE

Remote mounted elevated coolers have a maximum pipe length of 30 feet (9 M) (each way) and a maximum height of 20 feet (6 M) with a minimum of fittings. Engineering will review all remote elevated cooler applications and recommend pipe size on an individual basis. Customer Service should include the engineering recommendation in the special order sent to Engineering.

Kit number EAQ68330 includes the oil stop valve, check valve and flanges and must be installed on all remote elevated coolers per See FIGURE 5–2, page 35, and the following instructions.

1. Mount the check valve (90J113) as shown.
2. Mount the drain valves in the lowest section of the pipe on each side of the cooler connections.
3. Mount the oil stop valve (90AR243) in the line after the thermal mixing valve as shown.

Modifications to the control lines will be made at the factory per 288ECM810 schematic. Air to the oil stop valve must come from the upper fitting in the separator housing, then pass through the 3–way pneumatic valve. Control air to the valve must be from the line between the tee and the orifice in the blowdown muffler line per FIGURE 5–2, page 35. When the machine blows down, it will activate the pneumatic valve and it will shut off the air and vent the line between the pneumatic control valve and the oil stop valve to atmosphere. This will shut the oil stop valve and prevent excessive oil from running into the reservoir.

Failure to install these parts could result in high oil carryover and cause the machine to shutdown on high discharge temperature.

COLD AMBIENT OPERATION – See “Installation for Cold Weather Operation,” page 10.

ADDITION OF OIL BETWEEN CHANGES must be made when the oil level is in the red range on the gauge as read while the unit is on. To add oil, follow these steps:

1. Be sure the unit is completely off and that no air pressure is in the oil reservoir.
2. Disconnect, tag and lockout the power supply to the starter.
3. Wipe away all dirt around the oil filler plug.
4. Remove the oil filler plug and add oil as required to return the oil level to the center of the green range on the gauge.
5. Install the oil filler plug, restore power, run and check for leaks.

DO NOT OVERFILL. The quantity required to raise the oil level from the red range center of the green range is shown in FIGURE 5–4, page 38. Repeated addition of oil between oil changes may indicate excessive oil carry–over and should be investigated.

DANGER

Air/oil under pressure will cause severe personal injury or death. Shut down compressor, relieve system of all pressure, disconnect, tag and lockout power supply to the starter before removing valves, caps, plugs, fittings, bolts, and filters.

CAUTION

Excessive oil carry–over can damage equipment. Never fill oil reservoir above the “FULL” marker.

LUBRICANT CHANGE PROCEDURE – Upgrading to a longer life lubricant is essentially a very worthwhile practice. Following are the primary steps to be completed when upgrading or changing the type of lubricant.

1. Thoroughly drain system:
 - Drain oil from air end and cooler while hot.
 - Break low point connections and drain oil from pipe runs.

- Dump oil from the filter and reinstall used filter.
2. Fill the system with a 50 percent charge of the new lubricant:
 - Start the machine and stay there to observe.
 - Allow the machine to run about five minutes at temperature, or until temperature stabilizes, then shut down.
 3. Thoroughly drain the machine.
 4. Change to a new filter and separator.
 5. Fill the system with a full charge of the new lubricant, then reinstall drain plug.
 6. Machine should then be run normally, however, total run time after the initial changeout should be 50 percent of normal anticipated service life of the new lubricant.
 - Drain all lubricant from the system, change the filter and separator, and replace with a full charge of the new lubricant.
 7. Subsequent lubricant changeouts should be at normal intervals. (See "Oil Change Interval" and chart below.)

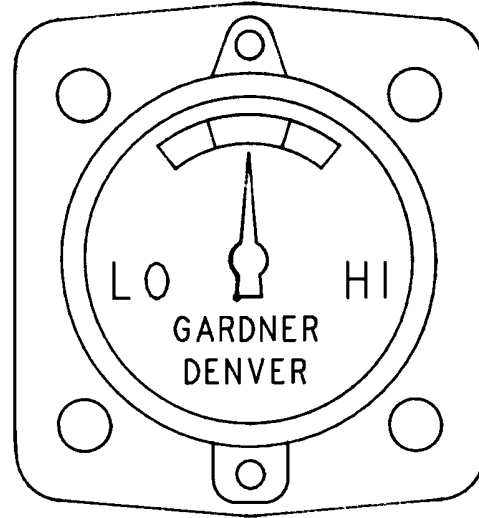

FIGURE 5-4 – OIL LEVEL GAUGE

OIL LEVEL GAUGE (FIGURE 1-3, page 2, and FIGURE 5-4) indicates the amount of oil in the oil reservoir. Read oil level only when unit is on. In operation the oil level will fluctuate as the compressor loads and unloads. Add oil only when the oil is at the bottom of the red range on the gauge as read when the compressor is on. Drain oil only when the oil level is above the center of the green range on the gauge as read when the compressor is on.

MOISTURE IN THE OIL SYSTEM – In normal humidity and with normal operating temperatures and pressures, the thermal mixing valve controls the oil temperature and prevents moisture contamination of the oil. Unusual cooling of the oil reservoir, short loaded cycle

in high humidity or malfunctions of the thermal valve may result in moisture in the oil system which is detrimental to compressor lubrication and could cause oil carryover. If moisture is observed in the oil reservoir, drain the moisture and correct the condition causing the accumulation. See "Compressor Oil System Check," page 43 and "Thermal Control (Thermostatic Mixing) Valve," page 40.

OIL CHANGE INTERVAL – Recommended oil change intervals are based on oil temperature. FIGURE 5-5, shows how the change interval is affected by temperature.

When operating conditions are severe (very dusty, high humidity, etc.), it will be necessary to change the oil more frequently. Operating conditions and the appearance of the drained oil must be surveyed and the oil change intervals planned accordingly by the user.

Discharge Temperature	AEON 4000 Change Interval	AEON 9000 SP Change Interval
Up to 180°F (82°C)	4000 hrs.	8000 hrs.
180° to 190°F (82° to 88°C)	3000 hrs.	6000 hrs.
190° to 200°F (88° to 93°C)	2000 hrs.	4000 hrs.
200°F+ (93°C)	1000 hrs.	2000 hrs.

FIGURE 5-5 – OIL CHANGE INTERVAL

Gardner Denver® offers a free oil analysis program with the AEON™ lubricants and we recommend a sample be sent in at 100 hours on a new unit.

DRAINING AND CLEANING OIL SYSTEM

 DANGER
<p>Air/oil under pressure will cause severe personal injury or death. Shut down compressor, relieve system of all pressure, disconnect, tag and lockout power supply to the starter before removing valves, caps, plugs, fittings, bolts, and filters.</p>

Always drain the complete system. Draining when the oil is hot will help to prevent varnish deposits and carry away impurities.

To drain the system, use one of the following methods:

1. If the unit is not elevated high enough to use the oil reservoir drain line to drain oil, a small hand, electric or air operated pump should be used to drain reservoir through the oil filler opening or from the drain valve.
2. If the unit is elevated so that the oil reservoir drain can be used, empty the oil reservoir through the drain valve to a suitable container or sump.
3. If the drained oil and/or the oil filter element are contaminated with dirt, flush the entire system: reservoir, oil cooler, mixing valve and lines. Inspect the oil separator elements for dirt accumulation; replace if necessary. If a varnish deposit exists, contact the factory for recommendations for removal of the deposit and prevention of varnish.

FILLING OIL RESERVOIR

 DANGER
<p>Air/oil under pressure will cause severe personal injury or death. Shut down compressor, relieve system of all pressure, disconnect, tag and lockout power supply to the starter before removing valves, caps, plugs, fittings, bolts, and filters.</p>

1. Be sure the unit is completely off and that no air pressure is in the oil reservoir.
2. Disconnect, tag and lockout the power supply to the starter.
3. Wipe away all dirt around the oil filler plug.
4. Remove the oil filler plug and add oil as required to return the oil level to the center of the green range on the gauge.
5. Install the oil filler plug and operate the unit for about a minute allowing oil to fill all areas of the system. Check for leaks.
6. Shut down unit, allowing the oil to settle, and be certain all pressure is relieved.
7. Add oil, if necessary, to bring level to the center of the green range on the gauge.

On unloaded operation and after shutdown some oil will drain back into the oil reservoir and the oil level gauge will read "FULL." DO NOT DRAIN OIL TO CORRECT. On the next start, oil will again fill the system and the gauge will indicate operating at the proper level. DO NOT OVERFILL as oil carryover will result. The quantity of oil required to raise the oil level from "ADD" to "FULL" is shown in FIGURE 5-6. Repeated addition of oil between changes may indicate excessive oil carryover and should be investigated.

	100, 125, 150 & 200 HP (75, 93, & 112 KW)
Refill Capacity For Normal Oil Change	21.0 U.S. Gallons (79.5 Liters)
Red to Yellow Range	3.5 U.S. Gallons (13.25 Liters)

FIGURE 5-6 – APPROXIMATE OIL SYSTEM CAPACITIES

Use only CLEAN containers and funnels so no dirt enters the reservoir. Provide for clean storage of oils. Changing the oil will be of little benefit if done in a careless manner.



CAUTION

Excessive oil carry-over can damage equipment. Never fill oil reservoir above the "FULL" marker.

COMPRESSOR OIL FILTER (FIGURE 5-1) – This patented design screw on oil filter is a vital part in maintaining a trouble-free compressor, since it removes dirt and abrasives from the circulated oil. The oil filter relief valve is located in the manifold under the 1-1/4" pipe plug. The relief valve opens in the event the element becomes dirty enough to block the flow of oil.



CAUTION

Improper oil filter maintenance will cause damage to equipment. Replace filter element every 1000 hours of operation. More frequent replacement could be required depending on operating conditions. A filter element left in service too long may damage equipment.

Use only complete oil filter for replacement. The part number is on the filter head and in the parts list.

NOTICE

The head and the filter body are bonded together and cannot be purchased separately..

Use the following procedure to replace the filter. Do not disturb the piping.



DANGER

Air/oil under pressure will cause severe personal injury or death. Shut down compressor, relieve system of all pressure, disconnect, tag and lockout power supply to the starter before removing valves, caps, plugs, fittings, bolts, and filters.

1. Stop unit and be sure no air pressure is in the oil reservoir.
2. Unscrew oil filter from housing and remove.
3. Screw new oil filter into housing.
4. Run the unit and check for leaks.

COMPRESSOR OIL COOLER – RADIATOR TYPE (FIGURE 1-5, page 3) – The oil cooler motor and fan is mounted on the oil cooler module; air is exhausted through the oil cooler and away from the unit. Do not obstruct air flow to and from the oil cooler. Allow a minimum of three (3) feet clearance around the cooler. Keep both faces of cooler core clean for efficient cooling of compressor oil.

THERMAL CONTROL (THERMOSTATIC MIXING) VALVE is installed in system as shown in FIGURE 5-1, page 34. This valve is used to control temperature of the oil in both air-cooled radiator and water-cooled heat exchanger type oil cooler systems. On start-up with unit cold, element is open to bypass, allowing oil to pass directly from the reservoir to compressor during warm-up. As oil warms, element gradually closes to the bypass allowing more of the oil from the cooler to mix with oil from the bypass.

After the unit is warmed up, the mixing valve maintains oil injection temperature into the compressor at a minimum of 150° F (66° C). This system provides proper compressor warm-up and helps prevent moisture contamination of oil.

To check element, heat in oil – it should be fully extended at 150° F (66° C). If unit shuts down due to high air discharge temperature, it may be that one or both thermostatic mixing valve elements (FIGURE 5-1, page 34) are stuck open. Remove mixing valve and clean all parts thoroughly when flushing the oil system.

COMPRESSOR OIL COOLER – WATER-COOLED HEAT EXCHANGER (FIGURE 5-1, page 34) – The heat exchanger oil cooler is a multiple pass type, with water in the tubes and oil in the shell. The oil temperature is controlled by the thermal (thermostatic mixing) valve. The optional water control valve may be used to conserve water.

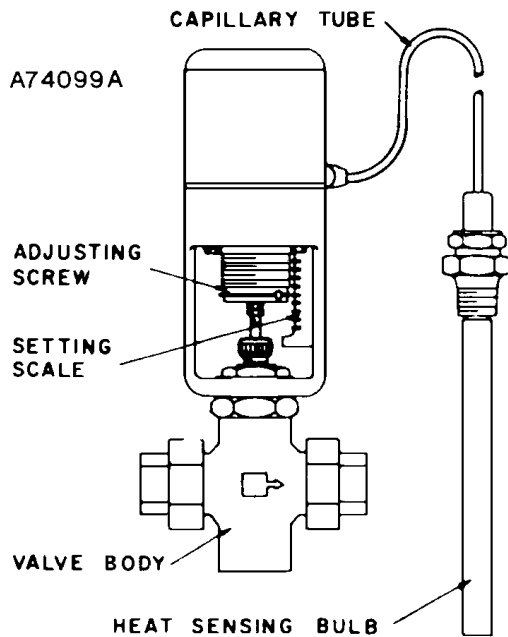

FIGURE 5-7 – WATER CONTROL VALVE

Oil cooler malfunction may be traced by checking pressure at oil inlet and outlet. At normal operating air service pressure (65 to 150 psig, 4.5 to 10.3 Bars) with the unit warm, a pressure drop of 3 to 15 psi (.2 to 1 Bar) can be expected between the oil inlet and the oil outlet.

Water pressure drop from water inlet to outlet will vary with the inlet pressure and amount of water flowing. A normal pressure drop may range from 5 to 10 psi (.3 to .7 Bar). Any change in the pressure drop from that normally held may indicate tube leakage or fouling and should be investigated.

In many instances, the cooling water supply for the heat exchanger will contain impurities in solution and/or suspension. These substances can cause scale formation, corrosion and plugging of any water-cooled heat exchanger equipment. Disregarding the possibility that one or more of these conditions exist may result in increased maintenance and operation expense, reduced equipment life and emergency shutdown. It is strongly recommended that a reputable, local water treatment concern be engaged to establish the corrosion, scale forming and fouling tendency of the cooling water and take steps necessary to remedy the situation if a problem does exist. The need for water treatment may involve only filtration (screening) to remove debris, sand and/or salt in the cooling water supply. However, chemical treatment methods may be necessary in certain instances to inhibit corrosion and/or remove dissolved solids, to alter the water's tendency to form scale deposits, or prevent the growth of microorganisms. The normal maintenance program for the unit

should also include periodic cleaning of the tubes (water side) of the heat exchanger to remove deposits which enhance fouling and corrosion.

Hex head zinc anodes are used in the return bonnet (opposite end to the water pipe connections) of heat exchangers to provide internal water system corrosion protection. These anodes should be inspected periodically and replaced when the zinc has been reduced to about 1/2 inch (13mm) in length.

WATER FLOW CONTROL VALVE FOR HEAT EXCHANGER (Optional Equipment) (FIGURE 5-7) –

The water flow control valve is adjustable to compensate for varying water inlet temperatures and pressures and is to be mounted in the water outlet line after the oil cooler (FIGURE 5-1, page 34). Use the compressor discharge air temperature gauge on the instrument panel in setting the flow control valve. The compressor discharge temperature must be maintained a minimum of 10° F (5° C) above the dew point temperature at the maximum anticipated ambient; refer to FIGURE 5-8, page 42, for the dew point temperature at the operating pressure and ambient temperature of the application.

To decrease water flow (increase compressor discharge air temperature) turn the adjusting screw from left to right, increasing spring tension. **To increase water flow** (decrease compressor discharge air temperature) turn the adjusting screw in the opposite direction. The groove at the lower edge of the adjusting screw is an index line for use with the index scale 0 to 8 in obtaining a desired setting.

These valves must be handled with care and proper tools and techniques must be used when working on the valve.

Care must be used when handling the capillary tube; a kink or break in the tubing or connections will make the valve inoperative. Never attempt to change capillary length. Excess capillary tube should be carefully coiled and placed so that damage will not occur in normal maintenance or traffic past the unit.

If the leak develops through the packing, tighten the packing gland nut firmly with a wrench to reseal the packing around the valve stem, then back off the nut until loose, and finally retighten the nut finger tight. Tightening the packing nut too tight may cause erratic operation. An occasional drop of oil on the valve stem at the packing nut will prolong packing life.

If valve malfunctions, check for bent or binding, paint or corrosion on valve stem, foreign material in valve, erosion, or thermal system (capillary) failure. If foreign material or scale is likely, the use of a strainer in the inlet water line is recommended.

WATER SHUTOFF VALVE – WATER-COOLED HEAT EXCHANGER (Optional Equipment) (FIGURE 5-1, page 34) – A magnetic solenoid-operated water shutoff valve rated at 150 psig (10.3 Bars)

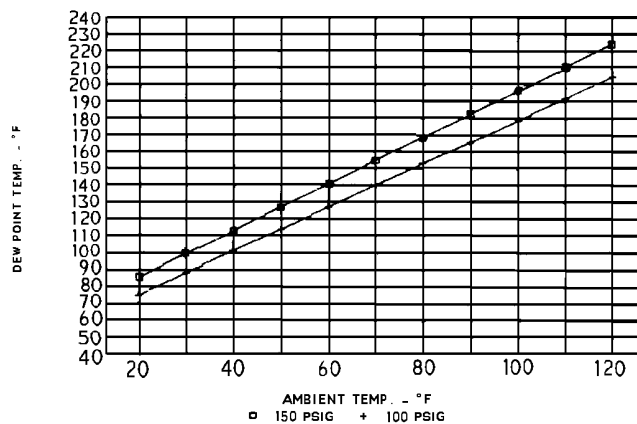
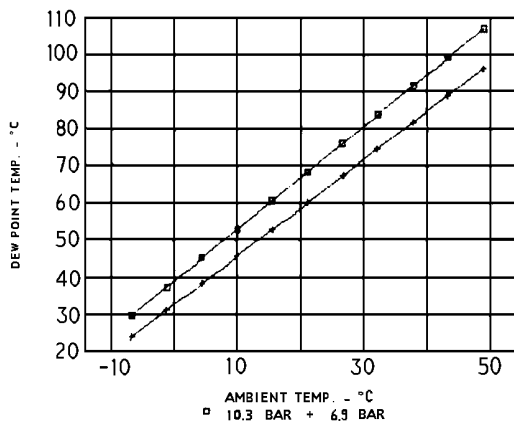

FIGURE 5-8 – DEW POINT TEMPERATURE VS. AMBIENT TEMPERATURE (100% RELATIVE HUMIDITY)

water pressure should be mounted in the water outlet line after the oil cooler. The valve should be wired into the compressor control circuit so that the valve opens to allow water to flow any time the compressor is running. When compressor stops under automatic control, or is shut off manually, the valve should close, stopping water flow through the system. See Wiring Diagrams in Section 4.

OIL RESERVOIR – The oil reservoir–separator combines multiple functions into one vessel. The lower half is the oil reservoir, providing oil storage capacity for the system and the top portion, a primary oil separation means. The reservoir also provides limited air storage for control and gauge actuation.

COMPRESSOR (GD ELIMINATOR) OIL SEPARATOR located in a separate housing, consists of a renewable cartridge-type separator element and provides the final removal of oil from the air stream (FIGURE 5-9).

Oil impinging on the inside of the separator element drains directly back into the oil reservoir by gravity. Oil collected outside the element is returned through tubing to the compressor cylinder.

Oil carryover through the service lines may be caused by a faulty oil separator, faulty minimum pressure valve, over-filling of the oil reservoir, oil that foams, oil return line malfunction or water condensate in the oil. If oil carryover occurs, inspect the separator only after it is determined that the oil level is not too high, the oil is not foaming excessively, the oil return line from the separator housing to the compressor cylinder is not clogged or pinched off, the check valve in the oil return line is functioning properly, and there is not water or an oil/water emulsion in the oil.

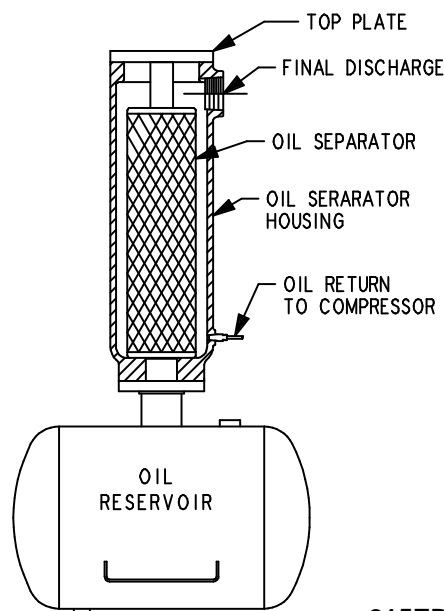

215EDM797 (Ref. Drawing)

FIGURE 5-9 – OIL SEPARATOR

Oil carryover malfunctions of the oil separator are usually due to using elements too long, heavy dirt or varnish deposits caused by inadequate air filter service, use of improper oil or using oil too long for existing conditions. A ruptured or collapsed separator element is usually due to heavy dirt or varnish buildup in the filtering material. Excessive tilt angle of the unit will also hamper separation and cause oil carryover.

Oil separator element life cannot be predicted; it will vary greatly depending on the conditions of operation, the quality of the oil used and the maintenance of the

oil and air filters. The condition of the separator can be determined by pressure differential gauging or by inspection.

Pressure Differential Gauging – The “CHANGE SEPARATOR” advisory will flash when the pressure differential across the oil separator reaches approximately 8 PSID (.55 Bar). Replace the oil separator element at this time. If ignored, the unit will shut down and the advisory will illuminate steadily when the pressure differential reaches 15 PSID (1 Bar).



CAUTION

Using an oil separator element at excessive pressure differential can cause damage to equipment. Replace the separator when the “Change Separator” advisory appears.

NOTICE

A sudden drop of zero pressure differential or sudden heavy oil carryover may indicate a ruptured element.

Inspection – After removal of separator element, shine a light inside the element to reveal areas of heavy dirt or varnish deposits or breaks (ruptures) in the element media.

Removal Of Oil Separator For Inspection Or Replacement:



DANGER

Air/oil under pressure will cause severe personal injury or death. Shut down compressor, relieve system of all pressure, disconnect, tag and lockout power supply to the starter before removing valves, caps, plugs, fittings, bolts, and filters.

1. Be certain unit is completely off and that no air pressure is in the oil reservoir.
2. Disconnect, tag and lockout power supply to the starter.
3. Remove screws holding the top plate to the separator housing. Lift the top plate from the separator housing.
4. Lift the separator from the separator housing.
5. Inspect and/or replace the separator as necessary. Be sure the o-ring is not damaged. Before installing (or reinstalling) any separator apply grease to the o-ring. Oil will be wiped off by the chamfer and the o-ring could be damaged.
6. Remove any gasket material adhering to top plate or separator housing, and install new gasket.
7. Lower the separator into the housing and center the separator on the chamfer. Press separator down into the housing. Do not use excessive force as separator damage can occur.
8. Place the spacer on the indent in the separator. Seat the top plate to the separator, spacer and separator housing. Install and tighten all cap screws.
9. Run the unit and check for leaks.

COMPRESSOR OIL SYSTEM CHECK – The following readings are based on ambient temperature of 80° F (27° C) for air-cooled oil cooler and 80° F inlet water on water-cooled oil cooler, with the system in good condition. Compressor should be at operating temperature at the time of checks. One-half hour of loaded operation is usually sufficient to reach level-out operating temperatures.

Air and Oil Discharge Temperature – 165° to 195° F (74° to 91° C) – Read at gauge on the instrument panel or check with a thermometer at the discharge housing.

Compressor Oil Inlet Temperature – 150° to 160° F (66° to 71° C) – Install a tee at the oil filter outlet and check with a thermometer.

Oil Inlet Pressure – Check at the fitting in the line near the compressor oil inlet. With air receiver pressure at 100 psi (6.9 Bar), oil inlet pressure should be 55–60 psig (3.8–4.1 Bar).

Oil Cooler Oil Pressure Differential (Air-Cooled Radiator) – Check differential across oil system by measuring oil inlet pressure as described above.

Oil Cooler Oil Pressure Differential (Water-Cooled Heat Exchanger) – 2 to 25 PSID (.1 to 1.7 Bar) (65 to 150 PSIG, 4.5 to 10.3 Bars Receiver Pressure) – Check that oil inlet pressure is correct or measure the differential between drains on the oil cooler shell.

Oil Cooler Temperature Differential (Air-Cooled Radiator) – The oil temperature differential depends on the temperature of the air at the oil cooler fan and cleanliness of core faces. As ambient temperatures and core restrictions increase, the oil cooler outlet temperature will increase. The oil inlet temperature is approximately the same as air discharge temperature – see the gauge on the instrument panel. The outlet oil temperature may be checked by installing a tee at the oil filter outlet.

Oil Cooler Temperature Differential (Water-Cooled Heat Exchanger) – The oil temperature differential depends on the inlet water temperature and the water flow

rate permitted by the water flow control valve setting. The oil inlet temperature is approximately the same as the air discharge temperature – see the gauge on the instrument panel. The oil outlet temperature may be checked by installing a tee at the oil filter outlet.

Oil Cooler Water Pressure Differential (Water-Cooled Heat Exchanger) – The water pressure differential through the heat exchanger will depend on the supply pressure, flow rate, cooler tube cleanliness and outlet pressure. The inlet and outlet water pressure may be checked at the pipe fittings supplied by the customer.

SECTION 6 AIR FILTER

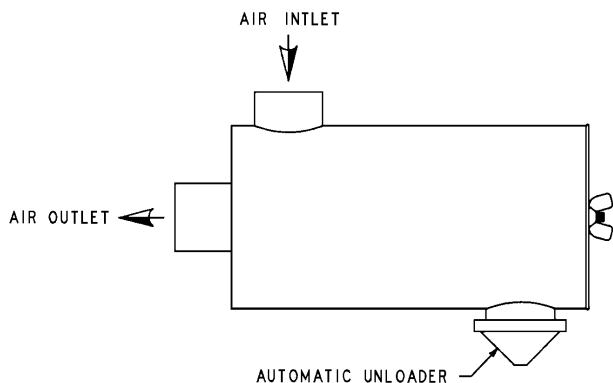

FIGURE 6-1 – HEAVY DUTY AIR FILTER (STANDARD)

HEAVY-DUTY AIR FILTER (FIGURE 6-1) furnished as standard equipment on units with an enclosure is a heavy-duty washable element dry type air filter. The air filter must receive proper maintenance if maximum service is to be obtained from the unit. Establishing adequate and timely filter service is **MOST IMPORTANT**. An improperly maintained air filter can cause a loss of compressor air delivery.

Filter Element – Service the air filter element when the “CHANGE AIR FILTER” LED is illuminated. Clean every 50 to 150 operating hours depending on dust conditions.

NOTICE

Use only genuine Gardner Denver air filter elements on Gardner Denver compressor units. Genuine parts are available through your authorized Gardner Denver distributor.

To service:

1. Remove the wingnut and pull out the filter element.
2. Visually inspect the element. If cleaning is not necessary, reinstall the filter element. If the element requires cleaning, follow steps 3, 4 and 5.

3. Wash the element by soaking about 15 minutes in warm water with a mild nonsudsing detergent. Rinse the element thoroughly with clean water; a hose may be used if the water pressure does not exceed 40 psig (2.8 Bars).
4. Inspect the element for ruptures or cracks in the pleated media; replace the element if any are found. Inspect the gasket on the bottom (outlet end) of the element; replace the entire element if the gasket is damaged. A spare element will keep down time to a minimum.
5. Allow the element to air dry **COMPLETELY**. Do not expose the element to heat over 150° F (66° C). Install the element in the filter body and fasten securely with the wing nut.

⚠ WARNING

Do not oil this element. Do not wash in inflammable cleaning fluids. Do not use solvents other than water. Improper cleaning may damage the element.

NOTICE

Never operate the unit without the element. Never use elements that are damaged, ruptured or wet. Never use gaskets that won't seal. Keep spare elements and gaskets on hand to reduce downtime. Store elements in a protected area free from damage, dirt and moisture. Handle all parts with care.

Filter Element Life – The element should be replaced after six (6) cleanings or if:

1. Visual inspection indicates a rupture, crack or pin hole in the pleated media. Inspection should be done by placing a bright light inside the element.

2. Pressure drop through a filter with a freshly cleaned element is below three (3) inches (76 mm) of water with the compressor running at full load – this would indicate a rupture or crack.

Inlet Tube – Inspect the inlet screen and tube for dirt accumulation each time the filter is serviced. Clean the

tube when required by ramming a clean dry cloth through the tube. Wipe the inside of the filter body to remove any dirt falling from the inlet tube before reinstalling the element.

Causes of short element life include: severe dust conditions, infrequent servicing, improper cleaning, or contamination by oil or chemical fumes.

SECTION 7 COUPLING

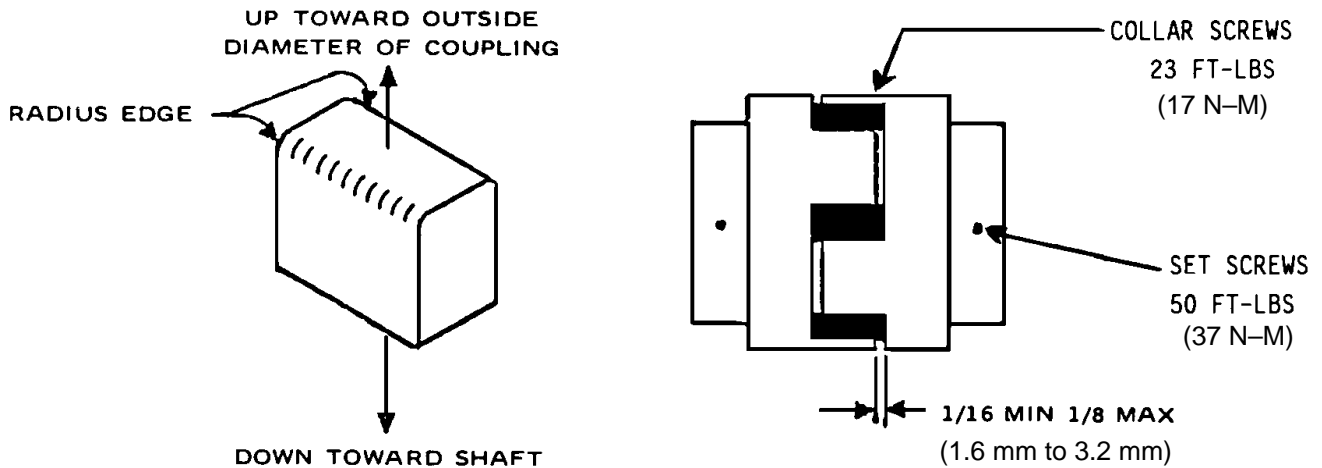

FIGURE 7-1 – INSTALLATION OF COUPLING CUSHIONS

DANGER

Rotating machinery can cause personal injury or death. Turn the unit completely off, open the main disconnect, tag and lockout before servicing the coupling.

- Working through the coupling guard opening, center the coupling over the gap between the shafts, maintaining the gap as shown in FIGURE 7-1 between the ends of the jaws on one coupling body and the flange on the opposite coupling body. Tighten set screws in each coupling body.
- Insert individual cushions as shown in FIGURE 7-1 and slide the collar over the cushions and secure with cap screws. Reinstall the cover plate.

DANGER

Rotating machinery can cause personal injury or death. Do not operate unit with either the coupling guard or the collar removed. All bolts and screws must be properly tightened.

COUPLING – The motor and compressor are direct connected by a resilient type flexible coupling with several individual cushions. The coupling does not require lubrication.

If maintenance on mating parts is required, reassemble coupling as follows:

Individual Cushion Design (FIGURE 7-1)

- Slide coupling halves over shaft extensions. Be sure the collar is installed on the shaft behind one coupling body.
- Assemble the motor to the compressor.

Alignment – The coupling is permanently aligned by the flanges on the compressor and motor.

SECTION 8 MAINTENANCE SCHEDULE

SERVICE CHECK LIST –

Air Filter – Operating conditions determine frequency of service. If the “CHANGE AIR FILTER” message is displayed, air filter requires servicing or changing. See “Air Filter,” Section 6, page 45.

Oil Separator – Operating conditions determine frequency of service. If the “CHANGE SEPARATOR” message is displayed, the oil separator element requires changing. See “Compressor Oil Separator” in Section 5, page 42, for further details.

Motor Lubrication – Refer to Section 2, page 14, and Maintenance Schedule Chart below.

Every 8 Hours Operation

1. Check the reservoir oil level – add oil if required. See Section 5, page 48. If oil consumption is high, refer to “Excessive Oil consumption, page 50. DO NOT MIX LUBRICANTS.
2. Observe if the unit loads and unloads properly.
3. Check discharge pressure and temperature.
4. Check Panel LED’s for advisories.

Every 125 Hours Operation

1. Check for dirt accumulation on oil/aftercooler core faces and the cooling fan. If cleaning is required, clean the exterior fin surfaces of the cores by blowing compressed air carrying a nonflammable safety solvent in a direction opposite that of the cooling fan air flow. This cleaning operation will keep the exterior cooling surfaces clean and ensure effective heat dissipation.

Every 1000 Hours Operation

1. Change the oil filter element.

Every 4000 Hours Operation

1. Change the compressor lubricant. UNDER ADVERSE CONDITIONS, CHANGE MORE FREQUENTLY (refer to “Oil Change Interval”, page 38). Flush system if required.

Every Year

1. Check the relief valve for proper operation. See Section 4, page 18.

MAINTENANCE SCHEDULE (See detail notes above)

Maintenance Action

	As Indicated By Auto-Sentry® Controller	Every 8 Hours	Every 125 Hours	Every 1000 Hours	Every 4000* Hours	Every Year
Change Air Filter	•					
Change Oil Separator	•					
Check Reservoir Oil Level		•				
Check For Proper Load/Unload		•				
Check Discharge Pressure/Temp		•				
Check Dirt Accumulation on Cooler			•			
Change Oil Filter Element	•			•		
Change Compressor Lubricant (AEON 4000)	•				•	
Check Relief Valve						•

* See Oil Change Interval Chart, FIGURE 5–5, Page 38, for specific lubricant life.

SECTION 9 TROUBLE SHOOTING

SYMPTOM	POSSIBLE CAUSE	REMEDY
Compressor fails to start.	<ol style="list-style-type: none"> 1. Wrong lead connections. 2. Blown fuses in control box. 3. Motor starter overload heaters tripped. 4. Pressure in reservoir. 5. Read error message on control panel. 6. Remote Contact is open (terminals 6 & 9). 	<ol style="list-style-type: none"> 1. Change leads. 2. Replace fuse. 3. Reset and investigate cause of overload. 4. Inspect blowdown valve and muffler. 5. Take appropriate action. See manual 13-9/10-647. 6. Replace switch or jumper.
Compressor starts but stops after a short time.	<ol style="list-style-type: none"> 1. High discharge temperature. 2. High discharge temperature switch malfunction. 3. Blown fuse in starter/control box. 4. Motor starter overload heaters trip. 	<ol style="list-style-type: none"> 1. See "High Discharge Air Temperature," this section, page 50. 2. Replace switch. 3. Replace fuse (investigate if fuses continue to blow). 4. Reset and investigate cause of overload.
Compressor does not unload (or load).	<ol style="list-style-type: none"> 1. Improperly adjusted control. 2. Air leak in control lines. 3. Restricted control line. 4. Blowdown valve malfunction. 	<ol style="list-style-type: none"> 1. Refer to manual 13-9/10-647 and adjust control. 2. Determine source of leak and correct. 3. Clean control lines. 4. Repair, clean or replace valve.
Compressor cycles from load to unload excessively.	<ol style="list-style-type: none"> 1. Insufficient receiver capacity. 2. Restriction in control tubing. 	<ol style="list-style-type: none"> 1. Increase receiver size. 2. Inspect and clean control tubing.

SYMPTOM	POSSIBLE CAUSE	REMEDY
Compressor is low on delivery and pressure.	<ol style="list-style-type: none"> 1. Restricted air filter. 2. Sticking inlet valve. 3. Unload pressure adjusted too low. 4. Minimum pressure valve stuck closed. 	<ol style="list-style-type: none"> 1. Clean or replace filter. 2. Inspect and clean inlet valve. 3. Adjust the unload pressure. See manual 13-9/10-647. 4. Disassemble and clean valve.
High discharge air temperature.	<ol style="list-style-type: none"> 1. Thermostatic mixing valve stuck open. 2. Dirty or clogged cooler face. 3. Insufficient cooling air flow. 4. Clogged oil filter or cooler (interior). 5. Low compressor oil. 	<ol style="list-style-type: none"> 1. Repair or replace valve. 2. Clean cooler. 3. Provide unrestricted supply of cooling air. 4. Replace filter or clean cooler. 5. Add oil to proper level.
Excessive Oil Consumption	<ol style="list-style-type: none"> 1. Oil carryover through lines. 2. Oil leaks at all fittings and gaskets. 	<ol style="list-style-type: none"> 1. See "Oil Carryover", below. 2. Tighten or replace fittings or gasket.
Oil Carry-Over	<ol style="list-style-type: none"> 1. Overfilling the reservoir. 	<ol style="list-style-type: none"> 1. Drain excess oil from system.

 **DANGER**

Air/oil under pressure will cause severe personal injury or death. Shut down compressor, relieve system of all pressure, disconnect, tag and lockout power supply to the starter before removing valves, caps, plugs, fittings, bolts, and filters.

- | | |
|--|---|
| 2. Clogged, broken or loose oil return lines | 2. Tighten or replace faulty lines. |
| 3. Ruptured oil separator element. | 3. Replace element. |
| 4. Loose assembly. | 4. Tighten all fittings and gaskets. |
| 5. Foam caused by use of incorrect oil. | 5. Use Gardner Denver® AEON™ 9000 SP Lubricating Coolant. |
| 6. Inoperative minimum pressure valve. | 6. Clean out or replace valve. |

SYMPTOM	POSSIBLE CAUSE	REMEDY
Oil Carry-Over (Continued)	<ul style="list-style-type: none"> 7. Operation at elevated discharge temperatures. 8. Scavenge line check valve failure. 9. Water condensate in oil. 	<ul style="list-style-type: none"> 7. Reduce temperature. See High Discharge Air Temperature, page 50, this section. 8. Replace check valve. 9. Check oil reservoir temperature and if low, change thermal mixing valve element to higher temperature.

NOTICE

Gardner Denver factory remanufactured replacement compressor air end units are available from your authorized distributor, on an exchange basis, for all rotary screw compressor units.

GENERAL PROVISIONS AND LIMITATIONS

Gardner Denver Machinery Inc. (the "Company") warrants to each original retail purchaser ("Purchaser") of its new products from the Company or its authorized distributor that such products are, at the time of delivery to the Purchaser, made with good material and workmanship. No warranty is made with respect to:

1. Any product which has been repaired or altered in such a way, in the Company's judgment, as to affect the product adversely.
2. Any product which has, in the Company's judgment been subject to negligence, accident, improper storage, or improper installation or application.
3. Any product which has not been operated or maintained in accordance with the recommendations of the Company.
4. Components or accessories manufactured, warranted and serviced by others.
5. Any reconditioned or prior owned product.

Claims for items described in (4) above should be submitted directly to the manufacturer.

WARRANTY PERIOD

The Company's obligation under this warranty is limited to repairing or, at its option, replacing, during normal business hours at an authorized service facility of the Company, any part which in its judgment proved not to be as warranted within the applicable Warranty Period as follows.

COMPRESSOR AIR ENDS

Compressor air ends, consisting of all parts within and including the compressor cylinder and gear housing, are warranted for 24 months from date of initial use or 27 months from date of shipment to the first purchaser, whichever occurs first.

Any disassembly or partial disassembly of the air end, or failure to return the "unopened" air end per Company instructions, will be cause for denial of warranty.

OTHER COMPONENTS

All other components are warranted for 12 months from date of initial use or 15 months from date of shipment to first purchaser, whichever occurs first.

LABOR TRANSPORTATION AND INSPECTION

The Company will provide labor, by Company representative or authorized service personnel, for repair or

replacement of any product or part thereof which in the Company's judgment is proved not to be as warranted. Labor shall be limited to the amount specified in the Company's labor rate schedule.

Labor costs in excess of the Company rate schedule amounts or labor provided by unauthorized service personnel is not provided for by this warranty.

All costs of transportation of product, labor or parts claimed not to be as warranted and, of repaired or replacement parts to or from such service facilities shall be borne by the Purchaser. The Company may require the return of any part claimed not to be as warranted to one of its facilities as designated by Company, transportation prepaid by Purchaser, to establish a claim under this warranty.

Replacement parts provided under the terms of the warranty are warranted for the remainder of the Warranty Period of the product upon which installed to the same extent as if such parts were original components.

DISCLAIMER

THE FOREGOING WARRANTY IS EXCLUSIVE AND IT IS EXPRESSLY AGREED THAT, EXCEPT AS TO TITLE, THE COMPANY MAKES NO OTHER WARRANTIES, EXPRESSED, IMPLIED OR STATUTORY, INCLUDING ANY IMPLIED WARRANTY OF MERCHANTABILITY.

THE REMEDY PROVIDED UNDER THIS WARRANTY SHALL BE THE SOLE, EXCLUSIVE AND ONLY REMEDY AVAILABLE TO PURCHASER AND IN NO CASE SHALL THE COMPANY BE SUBJECT TO ANY OTHER OBLIGATIONS OR LIABILITIES. UNDER NO CIRCUMSTANCES SHALL THE COMPANY BE LIABLE FOR SPECIAL, INDIRECT, INCIDENTAL OR CONSEQUENTIAL DAMAGES, EXPENSES, LOSSES OR DELAYS HOWSOEVER CAUSED.

No statement, representation, agreement, or understanding, oral or written, made by any agent, distributor, representative, or employee of the Company which is not contained in this Warranty will be binding upon the Company unless made in writing and executed by an officer of the Company.

This warranty shall not be effective as to any claim which is not presented within 30 days after the date upon which the product is claimed not to have been as warranted. Any action for breach of this warranty must be commenced within one year after the date upon which the cause of action occurred.

Any adjustment made pursuant to this warranty shall not be construed as an admission by the Company that any product was not as warranted.

Gardner
Denver

For additional information contact your local representative or Gardner Denver Machinery Inc., Customer Service Department, 1800 Gardner Expressway, Quincy, Illinois 62301
Telephone: (800) 682-9868 FAX: (217) 224-7814



Sales and Service in all major cities.

For parts information, contact Gardner Denver, Master Distribution Center, Memphis, TN
Telephone: (800) 245-4946 FAX: (901) 542-6159

Specifications subject to change without notice.
Copyright 1996 Gardner Denver Machinery Inc.

Litho in U.S.A.