

Received 4/19/93

Price \$ 5.00

GARDNER-DENVER®

13-9-645X
1st Edition
March, 1993

**ELECTRA-SAVER II® STATIONARY
BASE-MOUNTED COMPRESSOR
INTERNATIONAL 50/60 HZ**

MODELS

EBQQNB, EBQSNB - 93 KW (125 HP)

EBQQOB, EBQSOB - 112 KW (150 HP)

**OPERATING AND
SERVICE MANUAL**

**COOPER**

Gardner-Denver
Industrial Machinery

**MAINTAIN COMPRESSOR RELIABILITY AND PERFORMANCE WITH
GENUINE GARDNER-DENVER AND JOY COMPRESSOR
PARTS AND SUPPORT SERVICES**

Gardner-Denver and Joy Compressor genuine parts, engineered to original tolerances, are designed for optimum dependability --- specifically for Gardner-Denver and Joy compressor systems. Design and material innovations are the result of years of experience with hundreds of different compressor applications. Reliability in materials and quality assurance are incorporated in our genuine replacement parts.

Your authorized international servicing distributor offers all the backup you'll need. A worldwide network of authorized distributors provides the finest product support in the air compressor industry.

Your local authorized international servicing distributor maintains a large inventory of genuine parts and he is backed up for emergency parts by direct access to the Gardner-Denver Industrial Machinery Master Distribution Center (MDC) in Memphis, Tennessee, USA.

Your authorized international servicing distributor can support your Gardner-Denver or Joy air compressor with these services:

1. Trained parts specialists to assist you in selecting the correct replacement parts.
2. A full line of factory tested AEON™ compressor lubricants specifically formulated for use in Gardner-Denver and Joy compressors.
3. Repair and maintenance kits designed with the necessary parts to simplify servicing your compressor.

Authorized international servicing distributor service technicians are factory-trained and skilled in compressor maintenance and repair. They are ready to respond and assist you by providing fast, expert maintenance and repair services.



For the location of your local authorized Gardner-Denver and Joy Air Compressor dealer refer to the local yellow pages of your phone directory or contact:

**Distribution Center:
Gardner-Denver
Industrial Machinery Division
Master Distribution Center
5585 East Shelby Drive
Memphis, TN 38115
Phone: (901) 363-6100
Fax: (901) 393-1095**

**Factory
Gardner-Denver
Industrial Machinery Division
1800 Gardner Expressway
Quincy, IL 62301
Phone: (217) 222-5400
Fax: (217) 223-5897**

FOREWARD

Gardner-Denver Rotary Screw compressors are the result of advanced engineering and skilled manufacturing. To be assured of receiving maximum service from this machine the owner must exercise care in its operation and maintenance. This book is written to give the operator and maintenance department essential information for day-to-day operation, maintenance and adjustment. Careful adherence to these instructions will result in economical operation and minimum downtime.

 DANGER
Failure to observe a DANGER notice could result in injury to, or death of personnel.
 WARNING
Failure to observe a WARNING notice could result in damage to equipment.
 CAUTION
CAUTION notices set forth general reminders of good safety practice, or direct attention to unsafe practices.
NOTICE
Information furnished in a NOTE will include general information or the highlights of a procedure.

This book covers the following models:

KW (HP)	BARS (PSIG)	Air Cooled	Water Cooled	Parts List
93 (125)	6.9, 8.6, 10.3 (100, 125, 150)	EBQQNB	EBQSNB	13-9-558X
112 (150)	6.9, 8.6, 10.3 (100, 125, 150)	EBQQOB	EBQSOB	13-9-558X

TABLE OF CONTENTS

GENERAL INFORMATION.....	SECTION 1
INSTALLATION.....	SECTION 2
STARTING AND OPERATING PROCEDURES	SECTION 3
CONTROLS AND INSTRUMENTS	SECTION 4
LUBRICATION, OIL COOLER, OIL FILTER AND SEPARATOR	SECTION 5
AIR FILTERS	SECTION 6
COUPLING	SECTION 7
MAINTENANCE SCHEDULE	SECTION 8
TROUBLE SHOOTING.....	SECTION 9

INDEX

NOTE: Numbers preceding dash are Section Numbers -- Numbers following dash are Page Numbers

Air Control Components	4-3	LUBRICATION, OIL COOLER, OIL FILTER & SEPARATOR (SECTION 5).....	5-1
Air Cooled Unit Installation.....	2-1	MAINTENANCE SCHEDULE (SECTION 8)	8-1
Air Filter Element Life	6-2	Minimum Pressure/Check Valve	4-3
Air Filter Element - Service Instructions	6-1	Moisture in the Oil System	5-6
Air Filter Vacuum Switch	4-4	Motor Lubrication	2-6
AIR FILTERS (SECTION 6)	6-1	Motor Protection Devices	4-1
Air/Oil Flow Diagram	5-2, 5-4	Oil Cooler (Water Cld.) - Water Flow Control Valve	5-8
Air/Oil Flow Diagram - Remote Overhead Cooler...	5-4	Oil Cooler (Water Cld.) - Water Shutoff Valve	5-8
Auto Sentry-ES, Controller Display.....	4-5	Oil Cooler - Radiator Type	5-8
Auto Sentry-ES, Operation.....	4-5	Oil Cooler - Water Cooled	5-8
Auto Sentry-ES, Operation (Automatic Mode)	4-5	Oil Filter	5-7
Auto Sentry-ES, Operation (Constant Run Mode)	4-5	Oil Level Gauge	5-6
Auto Sentry-ES, Operation (Low Demand Mode)	4-5	Oil Reservoir	5-9
Auto Sentry-ES, Operation (Sequence Mode)	4-5	Oil Reservoir Drain	2-2
Auto Sentry-ES, Programming And Set-Up Instruction.....	4-6	Oil Separator	5-10
Auxiliary Air Receiver.....	2-3	Oil Separator - Inspection	5-10
Basic Information	1-1	Oil Separator - Pressure Differential Gauging	5-9
Blowdown Valve	4-2	Oil Separator - Removal	5-10
Blowdown Valve Piping	2-4	Oil System Check	5-11
Cold Weather Operation	2-3	Outline Drawings	1-2
Control Schematics.....	4-9, 4-10, 4-11	Parallel Piping.....	2-5
CONTROLS & INSTRUMENTS (SECTION 4)	4-1	Pressure Regulator	4-3
COUPLING - DRIVE (SECTION 7)	7-1	Prestart-up Instructions	3-1
Decals	1-6, 1-7	Protective Devices and Shutdown	4-1
Discharge Service Line	2-4	Purge Air Valve	4-4
Electrical Wiring.....	2-5	Remote Overhead Cooler	5-3
Enclosure	2-2	Reservoir Pressure Transducer	4-4
Filling Oil Reservoir	5-7	Safety Precautions	1-4
Foundation	2-2	Separator Differential Pressure Shutdown	4-1
Gauges and Displays	4-3	Sequencing, Automatic Change	3-3
GENERAL INFORMATION (SECTION 1)	1-1	Sequencing, Installation	3-2
Grease Recommendations	2-6	Sequencing, Operation	3-2
Grounding	2-5	Sequencing, Other Features	3-3
Heat Exchanger (Oil) Piping	5-5	Series Piping.....	2-5
High Temperature Operation	5-1	Shuttle Valve	4-4
High Temperature Shutdown	4-1	Solenoid Valves - IVC and IVO.....	4-4
Inlet Line	2-3	Starter/Control Panel	4-4
Inlet Valve Control	4-3	STARTING & OPERATING PROCEDURES (SECTION 3)	3-1
INSTALLATION (SECTION 2)	2-1	Starting The Unit, Cold	3-2
Lifting Unit	2-1	Starting The Unit, Hot	3-2
Location	2-1	Stopping Unit	3-2
Lubricant, Addition of Oil Between Changes	5-5	System Pressure Transducer	4-4
Lubricant, Changing Type of Oil.....	5-1	Thermostatic Mixing Valve	5-8
Lubricant, Draining and Cleaning System.....	5-6	TROUBLE SHOOTING (SECTION 9)	9-1
Lubricant, Oil Specifications	5-1	Water Cooled Unit Installation	2-2
Lubricant, Recommended	5-1	Water Cooled Unit Piping	2-4
Lubricant Change Interval.....	5-6	Wiring Diagram	4-11

LIST OF ILLUSTRATIONS

FIGURE	DESCRIPTION	SECT-PAGE
1-1	Compression Cycle.....	1-1
1-2	Starter Control Box, Reservoir & Separator Housing.....	1-2
1-3	Starter Control Panel.....	1-2
1-4	Air Filter & Motor	1-2
1-5	Compressor Oil Cooler (Radiator Type)	1-3
1-6	Package Showing Compressor & Inlet Valve	1-3
2-1	Typical Compressor Room.....	2-1
2-2	Air Flow for Compression/Cooling	2-1
2-3	Cold Weather Installation.....	2-2
2-4	Heat Exchanger/Aftercooler Water Flow.....	2-4
2-5	Series Piping.....	2-5
2-6	Parallel Piping.....	2-5
4-1	Schematic Tubing Diagram	4-2
4-2	Blowdown Valves	4-2
4-3	Inlet Valve	4-3
4-4	Minimum Discharge Pressure Valve.....	4-3
4-5	Shuttle Valve.....	4-4
4-6	Control Schematic - Unloaded - Constant Speed	4-9
4-7	Control Schematic - Full Load	4-10
4-8	Control Schematic - Unloaded - Low Demand	4-11
4-9	Wiring Diagram.....	4-12
5-1	Flow Diagram - Air/Oil System.....	5-2
5-2	Approximate Oil System Capacities.....	5-3
5-3	Oil Flow Diagram - Remote Mounted Cooler.....	5-4
5-4	Cooler Drain Detail	5-5
5-5	Oil Level Gauge	5-6
5-6	Thermostatic Mixing Valve.....	5-8
5-7	Water Control Valve	5-8
5-8	Dew Point Temperature vs. Ambient.....	5-9
5-9	Oil Separator	5-10
6-1	Heavy Duty Air Filter	6-1
7-1	Installation of Coupling Cushions.....	7-1

SECTION 1 GENERAL INFORMATION

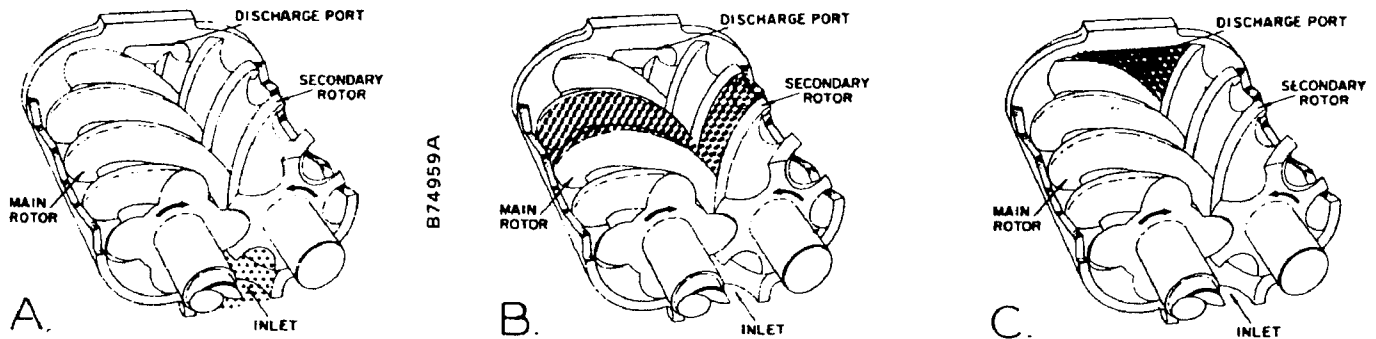

FIGURE 1-1 - COMPRESSION CYCLE

COMPRESSOR - The Gardner-Denver® Rotary Screw compressor is a single stage, positive displacement rotary machine using meshing helical rotors to effect compression. Both rotors are supported between high capacity roller bearings located outside the compression chamber. Single width cylindrical roller bearings are used at the inlet end of the rotors to carry part of the radial loads. Tapered roller bearings at the discharge end locate each rotor axially and carry all thrust loads and the remainder of the radial loads.

COMPRESSION PRINCIPLE (Figure 1-1) - Compression is accomplished by the main and secondary rotors synchronously meshing in a one-piece cylinder. The main rotor has four (4) helical lobes 90° apart. The secondary rotor has six (6) matching helical grooves 60° apart to allow meshing with main rotor lobes.

The air inlet port is located on top of the compressor cylinder near the drive shaft end. The discharge port is near the bottom at the opposite end of the compressor cylinder. *Figure 1-1 is an inverted view to show inlet and discharge ports.* The compression cycle begins as rotors unmesh at the inlet port and air is drawn into the cavity between the main rotor lobes and secondary rotor grooves (A). When the rotors pass the inlet port cutoff, air is trapped in the interlobe cavity and flows axially with the meshing rotors (B). As meshing continues, more of the main rotor lobe enters the secondary rotor groove, normal volume is reduced and pressure increases.

Oil is injected into the cylinder to remove the heat of

compression and seal internal clearances. Volume reduction and pressure increase continues until the air/oil mixture trapped in the interlobe cavity by the rotors passes the discharge port and is released to the oil reservoir (C). Each rotor cavity follows the same "fill-compress-discharge" cycle in rapid succession to produce a discharge air flow that is continuous, smooth and shock free.

AIR FLOW IN THE COMPRESSOR SYSTEM (Figure 5-1, page 2, Section 5) - Air enters the air filter and passes through the inlet unloader valve to the compressor. After compression, the air/oil mixture passes into the oil reservoir where most of the entrained oil is removed by velocity change and impingement and drops back into the reservoir. The air and remaining oil passes into the separator and separator housing where the oil is separated and passes through tubing connecting the separator housing and compressor. The air passes through the minimum pressure valve, discharge check valve and cooler, then to the plant air lines.

LUBRICATION, COOLING AND SEALING - Oil is forced by air pressure from the oil reservoir through the oil cooler, thermostatic mixing valve, and oil filter and discharges into the compressor main oil gallery. A portion of the oil is directed through internal passages to the bearings, gears and shaft oil seal. The balance of the oil is injected directly into the compression chamber to remove heat of compression, seal internal clearances and lubricate the rotors.

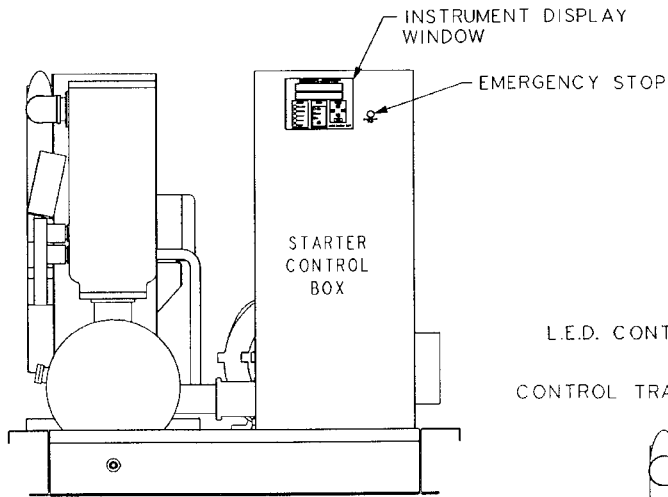

FIGURE 1-2 - STARTER CONTROL BOX, RESERVOIR & SEPARATOR HOUSING

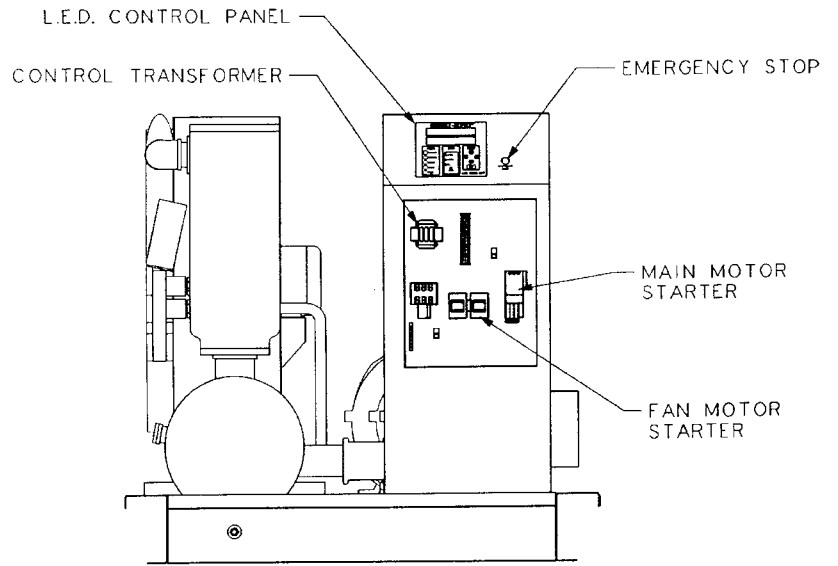

FIGURE 1-3 - STARTER CONTROL PANEL

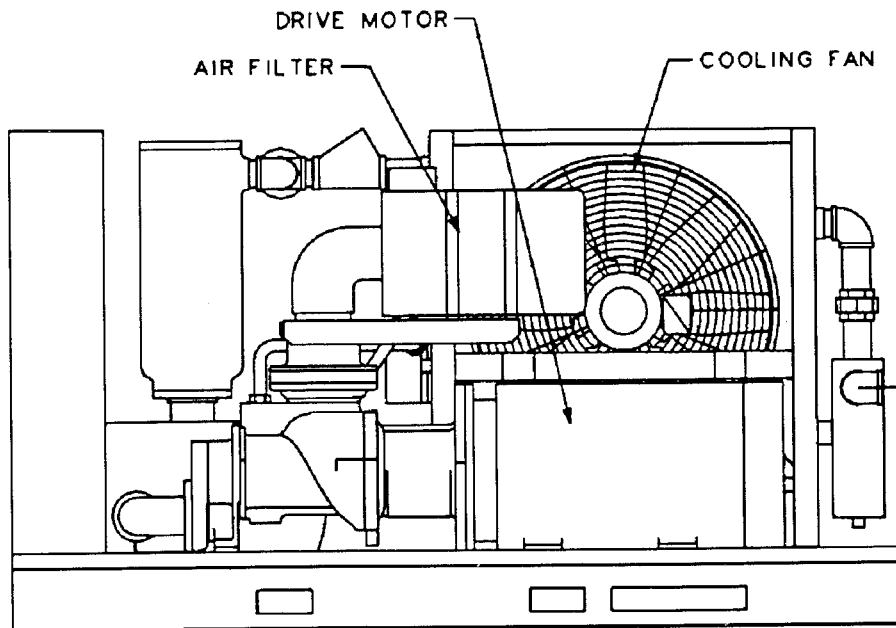

FIGURE 1-4 - AIR FILTER & MOTOR

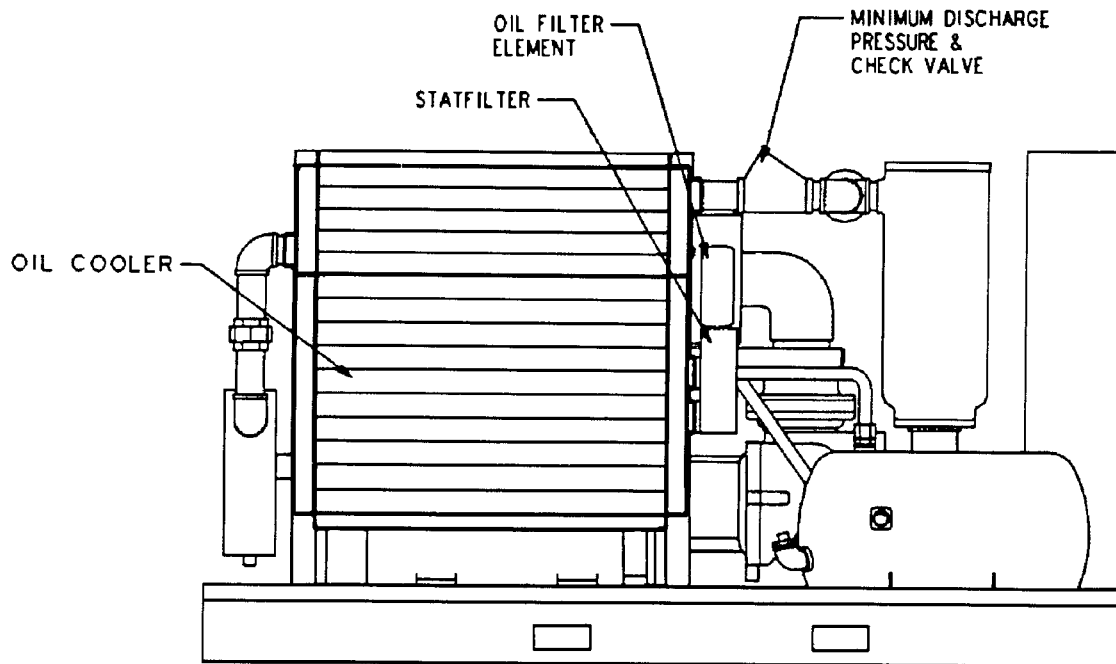

FIGURE 1-5 - COMPRESSOR OIL COOLER (RADIATOR TYPE),
RESERVOIR, SEPARATOR HOUSING & STAT FILTER

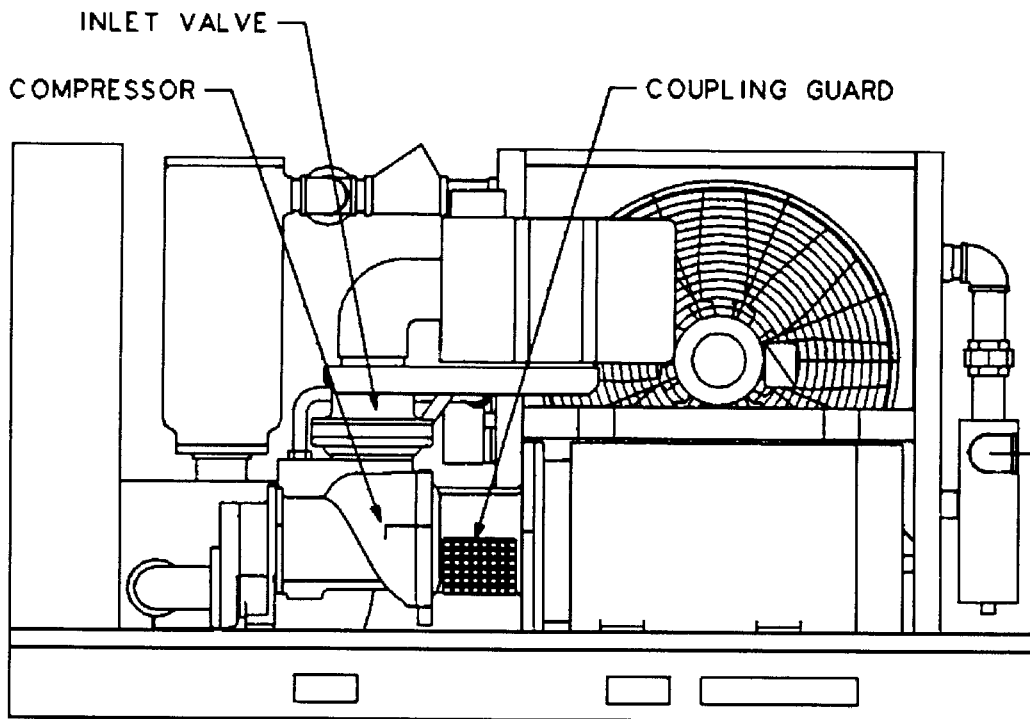

FIGURE 1-6 - COMPRESSOR & INLET VALVE

SAFETY PRECAUTIONS

Safety is everybody's business and is based on your use of good common sense. All situations or circumstances cannot always be predicted and covered by established rules. Therefore, use your past experience, watch out for safety hazards and be cautious.

Some general safety precautions are given below:

DANGER

Failure to observe these notices could result in injury to or death of personnel.

- **Keep fingers and clothing away from rotating fan, drive coupling, etc.**

- **Do not use the air discharge from this unit for breathing - not suitable for human consumption.**

- **Do not loosen or remove the oil filler plug, drain plugs, covers, the thermostatic mixing valve or break any connections, etc. in the compressor air or oil system until the unit is shut down and the air pressure has been relieved.**

- **Electrical shock can and may be fatal.**

- **Compressor unit must be grounded in accordance with International Electrical Code. A ground jumper equal in size to the equipment ground conductor must be used to connect the compressor motor base to the unit base.**

- **Fan motors must remain grounded to the main base through the starter mounting panel in accordance with International Electrical Code.**

- **Open main disconnect switch and lockout before working on the control.**

- **Disconnect the compressor unit from its power source, tag and lockout before working on the unit - this machine is automatically controlled and may start at any time.**

 **WARNING**

Failure to observe these notices could result in damage to equipment.

- Stop the unit if any repairs or adjustments on or around the compressor are required.
- Disconnect the compressor unit from its power source, tag and lockout before working on the unit - this machine is automatically controlled and may start at any time.
- An Excess Flow Valve should be on all compressed air supply hoses exceeding 12.5 mm (1/2 inch) inside diameter. Refer to local regulations.
- Do not exceed the rated maximum pressure values shown on the nameplate.
- Do not operate unit if safety devices are not operating properly. Check periodically. Never bypass safety devices.

DECALS

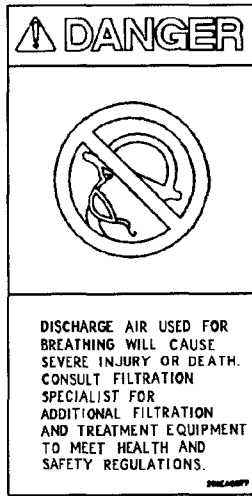

206EAQ077

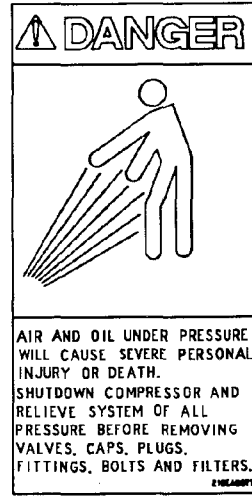

212EAQ077

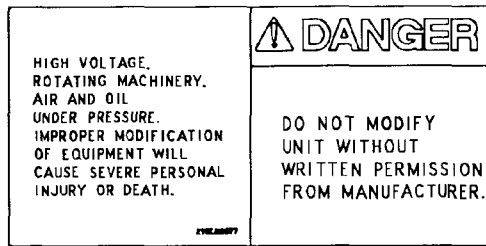

218EAQ077

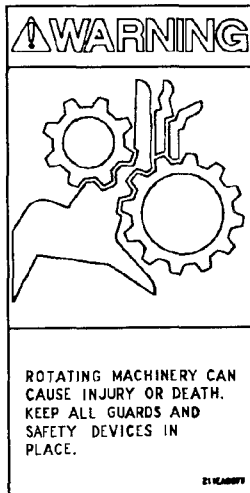

211EAQ077

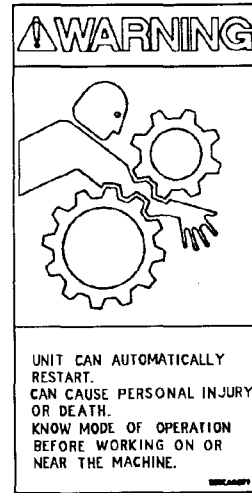

207EAQ077

DECALS

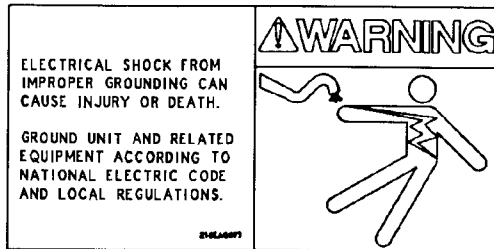

216EAQ077

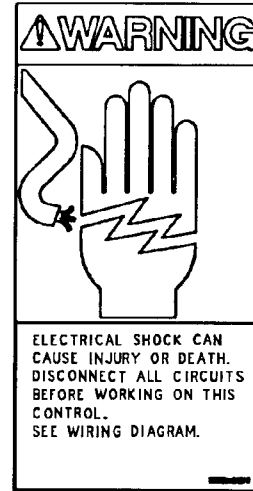

222EAQ077

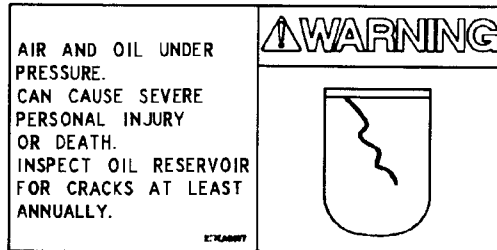

217EAQ077

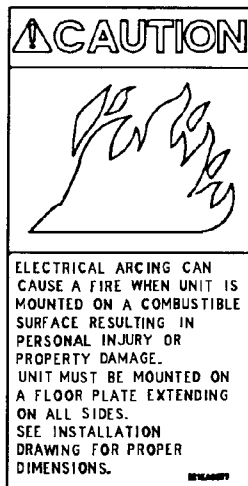

221EAQ077

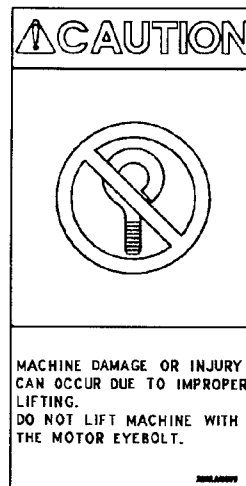

208EAQ077

SECTION 2 INSTALLATION

GENERAL - On receipt of the unit, check for any damage that may have occurred during transit or handling. Report any damage or missing parts as soon as possible.

CAUTION

Do not electric weld on the compressor or base; bearings can be damaged by passage of current.

LIFTING UNIT - Proper lifting and/or transporting methods must be used to prevent damage.

CAUTION

Lift compressor unit by base only. Do not use other places such as enclosure, motor, compressor oil discharge manifold and piping as lifting points.

DANGER

The eyebolts or lugs provided on the motor are for lifting the motor only and should not be used to lift any additional weight. All eyebolts must be securely tightened. When lifting the motor the lifting angle must not exceed 15 degrees. Failure to observe this warning may result in damage to equipment or personal injury.

Lifting slots are provided in the base for forklift use. Unit may also be moved into location by rolling on bars.

LOCATION - The compressor should be installed, whenever possible, in a clean, well-lighted, well-ventilated area with ample space all around for maintenance. Select a location that provides a cool, clean, dry source of air. In some cases it may be necessary to install the air filter at some distance from the compressor to obtain proper air supply.

Both the air-cooled and water-cooled units require cooling air as well as air to the compressor inlet. Proper ventilation **MUST** be provided; hot air must be exhausted from the compressor operating area. A typical inlet-outlet air flow arrangement is shown in Figure 2-1.

AIR-COOLED UNIT - A combination oil/aftercooler is supplied as standard equipment on all air-cooled units. The air-cooled unit with the standard enclosure requires

sufficient flow for the compressor oil/aftercooling system and for electric motor cooling, see Figure 2-2, below. Air is drawn into the unit at the motor side of the enclosure and is exhausted at the oil cooler side. Do not block the air flow to and from the unit. Allow 1.1M (3-1/2 feet) to the nearest obstruction on the starter end and control box end of the unit. Allow .9 M (3 feet) to the nearest obstruction above and on other sides of unit. For continuous efficiency, oil cooler cores must be periodically cleaned with either vacuum or compressed air. If wet cleaning is required, shield motor and spray on a mild soap solution and flush with clean water.

WARNING

For aluminum oil coolers, do not use any cleaning solution that is not compatible with aluminum. Use of improper solution may result in damage to cooler.

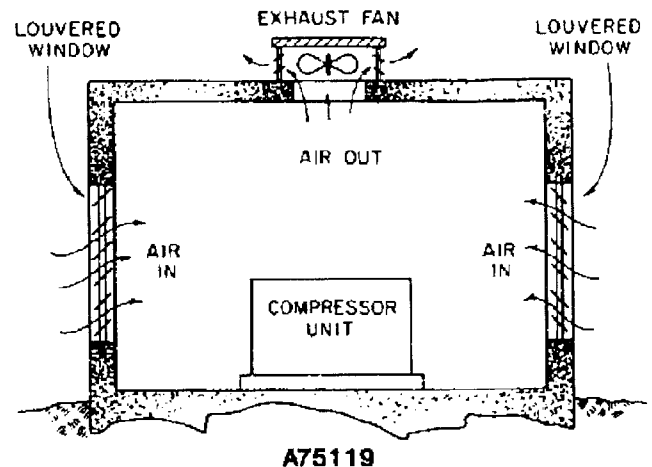

FIGURE 2-1 - TYPICAL COMPRESSOR ROOM

Minimum Air Flow* For Compression And cooling - M ³ /min. (CFM)		
KW (HP)	Air Cooled	Water Cooled
93, 112 (125, 150)	481 (17,000)	113 (4,000)

* 26.6° C (80°F) inlet air

FIGURE 2-2

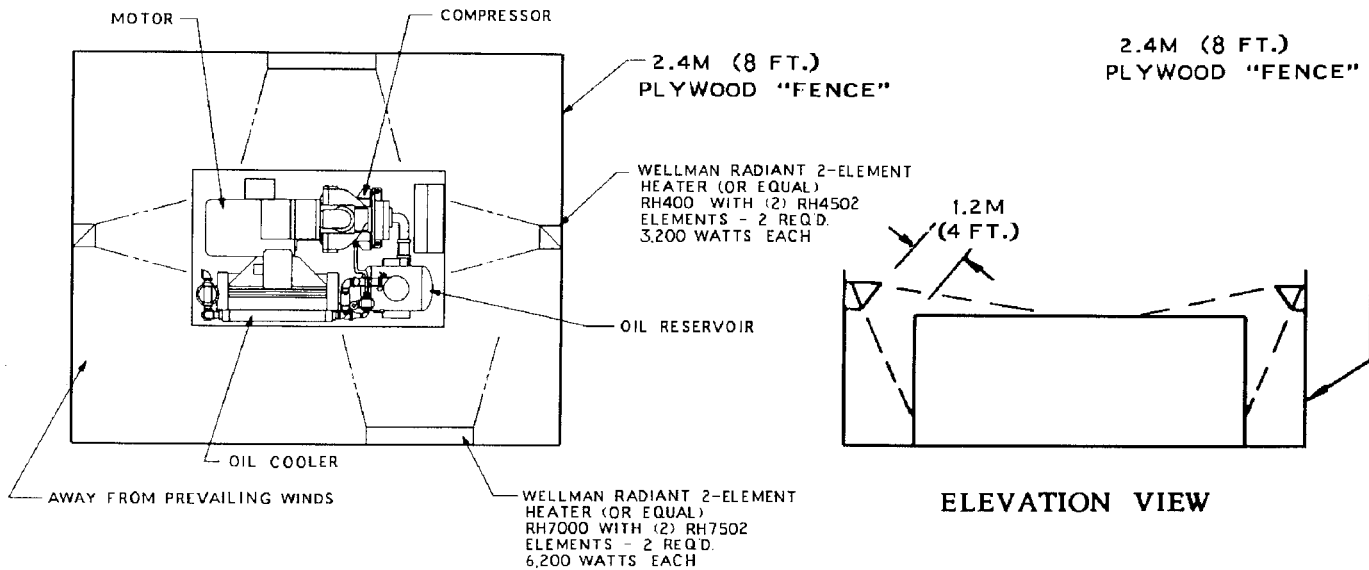

FIGURE 2-3 - COLD WEATHER INSTALLATION

WATER-COOLED UNITS - The water-cooled unit with the standard enclosure requires sufficient air flow for electric motor cooling, see Figure 2-2, page 1, this section. Air is drawn into the unit at the top of the enclosure and is exhausted at the motor side. Do not block air flow to and from the unit. Allow 1.1M (3-1/2 feet) to the nearest obstruction on the starter end and the control box side of the unit. Allow .9 M (3 feet) to the nearest obstruction above and on the other sides of the unit.

FOUNDATION - The G-D Rotary Screw compressor requires no special foundation, but should be mounted on a smooth, solid surface. Whenever possible install the unit near level. Temporary installation may be made at a maximum 10° angle lengthwise or 10° sidewise.

Mounting bolts are not normally required. However, installation conditions such as piping rigidity, angle of tilt, or danger of shifting from outside vibration or moving vehicles may require the use of mounting bolts and shims to provide uniform support for the base.

OIL RESERVOIR DRAIN - The oil drain is piped from the bottom of the reservoir to the side of the frame. This drain is approximately 115 mm (4.5 inches) above the floor level. If this is not sufficient to conveniently drain the oil some other methods of providing drain are:

1. Elevate the compressor unit on raised blocks to obtain the desired drain height.

 CAUTION
<p>If the compressor unit base is raised above floor level, the space between the floor and the base bottom must be closed with solid material all around to prevent recirculation of hot air from the oil cooler end and over temperature operation.</p>

2. Construct an oil sump or trough below the floor level and pump or bail the drained oil.
3. Pump oil from the reservoir filler opening or drain to a container.

ENCLOSURE - The compressor, electric motor, oil cooler and aftercooler are mounted inside the enclosure.

Service doors are provided for maintenance access. Be sure to allow enough space around the unit for the doors to open completely.

Any of the enclosure doors may be removed by opening the door and lifting it up slightly to disengage the hinges.

The motor inspection/air filter service panel is held by two latches and lifts away from the enclosure. The air outlet panel is attached by screws to the enclosure and is not readily removable.

INSTALLATION FOR COLD WEATHER OPERATION

- It is recommended that whenever possible the unit be installed inside a shelter that will be heated to temperatures above freezing (0°C, 32°F). This will eliminate many of the problems associated with operating the units outside in cold climates where freezing rain, drifting snow, freezing condensate and bitter cold temperatures are encountered.

Refer to Engineering Data Sheet 13-9-411 for the advantages of using the heat recovered from rotary compressors. This heat recovery could easily pay for an adequate shelter for the unit.

When an outside installation must be made, the precautions required will depend on how severe the environment. The following are general guidelines for outside installations:

Cold Weather (Down To -12° C, + 10° F)

1. Be sure all control lines, drains and traps are heated to avoid freezing of condensate. Heat tape with thermostat control is generally satisfactory for this purpose and can be obtained at various local plumbing or hardware outlets at nominal cost.
2. If an air-cooled aftercooler is to be used, provisions to bypass the aftercooler should be made. Since cold air contains very little moisture, successful operation can be achieved without the aftercooler.
3. Provide at least some simple shelter such as a plywood windbreak to protect against drifting snow.
4. Use only Gardner-Denver® AEON™ 9000 lubricant.
5. Monitor unit carefully during start-up and operation to be sure it is functioning normally.
6. Specify NEMA 4 enclosure for electrical devices.

Extreme Cold Weather Operation (Down To -40°C, -40°F)

In addition to the above, the following should be provided:

1. It will probably be necessary to provide shutters or to block off part of the cooler in some manner since the cooler is greatly oversized for operation in these low temperatures. Since shutters are not provided as a factory option, blocking off a portion of the cooler with plywood should be satisfactory.

2. Auto operation should not be used in extreme environments.
3. Some means of providing heat during shutdown should be provided. There are various methods to accomplish this, but since openings are not provided for sump heaters, the use of radiant heaters is recommended. The heaters should be sized to provide at least a -12° C (+ 10°F) environment for coolers, motor and sump. Figure 3-2 shows how these might be located in a typical installation and sizes required.

Remember unsheltered (outside) installations should be avoided where possible. Installation next to a heated building where enough heat can be used to keep the compressor room above freezing will save many complications in the operation and installation of the unit.

Refer to Engineering Data Sheet 13-9-411 for the advantages of using the heat recovered from rotary compressors. This heat recovery could easily pay for an adequate shelter for the unit.

AUXILIARY AIR RECEIVER - An auxiliary air receiver is not required if the piping system is large and provides sufficient storage capacity to prevent rapid cycling. When used, an air receiver should be of adequate size, provided with a relief valve of proper setting, a pressure gauge and a means of draining condensate.

MOISTURE SEPARATOR/TRAP - Since unit is equipped with a built-in aftercooler, a combination moisture separator and trap is furnished with the unit.

CONTROL PIPING - External control piping is not necessary since the unit is factory wired and piped for the control system specified.

INLET LINE - Where an inlet line is used between the air filter and the compressor, it must be thoroughly cleaned on the inside to prevent dirt or scale from entering the compressor. **If welded construction is used, the line must be shot blasted and cleaned to remove welding scale.** In either case, the inlet line must be coated internally by galvanizing or painting with a moisture and oil-proof sealing lacquer. Up to 3M (10 feet) in length, the inlet line should be the full size of the inlet opening on the compressor. If an extra-long line is necessary, the pipe size should be increased according to Inlet Line Chart below.

Accessibility for inlet air filter servicing must be considered when relocating the filters from the unit to a remote location.

INLET LINE LENGTHS

Length of Inlet Line	Diameter of Pipe Size
0 to 3 Meters (0 to 10 Feet)	Same as Compressor Inlet Opening
3 to 5 Meters (10 to 17 Feet)	One Size Larger Than Inlet Opening
5 to 11.5 Meters (17 to 38 Feet)	Two Sizes Larger Than Inlet Opening

HEAT EXCHANGER							
KW (HP)	Model	Water Temperature To Heat Exchanger				Max Water Flow L/S (GPM)	Approx. Water Press Drop @ 32° C (90° F) Water Temp. Bar (PSI)
		16°C (60°F)	21°C (70°F)	27°C (80°F)	32°C (90°F)		
93 KW (125 HP)	EBQSNB	.76 (12.0)	.95 (15.0)	1.26 (20.0)	1.89 (30.0)	2.52 (40.0)	.3 Bar (4.35 PSI)
112 KW (150 HP)	EBQSOB	.85 (13.4)	1.05 (16.7)	1.41 (22.3)	2.11 (33.5)	2.52 (40.0)	.3 Bar (4.35 PSI)

AFTERCOOLER							
KW (HP)	Model	Water Temperature To Heat Exchanger				Max Water Flow L/S Flow (GPM)	Approx. Water Press Drop @ 32° C (90° F) Water Temp. Bar (PSI)
		16°C (60°F)	21°C (70°F)	27°C (80°F)	32°C (90°F)		
93 KW (125 HP)	EBQSNB	.13 (2.1)	.16 (2.6)	.21 (3.4)	.33 (5.2)	3.47 (55)	Less than .1 Bar (1 PSI) for any flow rate shown in the table.
112 KW (150 HP)	EBQSOB	.17 (2.7)	.21 (3.3)	.28 (4.5)	.42 (6.7)	3.47 (55)	

FIGURE 2-4 - HEAT EXCHANGER (OIL COOLER-AFTERCOOLER)
APPROXIMATE WATER FLOW - LITERS/SECOND (U.S. GALLONS/MINUTE)

DISCHARGE SERVICE LINE - The discharge service line connection on both water-cooled and air-cooled units is made at the right hand corner of the unit, viewed from the opposite end from control panel side. When manifolding two or more rotary screw units on the same line, each unit is isolated by the check valve in the unit discharge line. If a rotary screw unit is manifolded to another compressor, be sure the other compressor has a check valve in the line between the machine and the manifold. If a rotary screw and a reciprocating compressor are manifolded together, an air receiver must be located between the two units.

BLOWDOWN VALVE PIPING - The blowdown valve is fitted with a muffler for operation indoors. If the installation requires, the muffler may be removed and the blowdown valve piped to the outside with a pipe size the same as the blowdown valve outlet connection.

WATER PIPING (Water-Cooled Heat Exchanger Models Only) - On machines equipped with water-cooled heat exchangers, the water inlet and outlet connections are located in the unit base flange on the left side of the unit.

The water source should be capable of supplying up to the maximum flow shown in Figure 2-4 at a minimum pressure of 2.8 Bars (40 psig); maximum allowable water pressure is 10.3 Bars (150 psig). The water flow rates shown in Figure 4-2 are approximate and a guide to sizing piping, cooling tower and other water system equipment.

The heat exchanger system is designed to operate with water inlet temperatures from 16° C to 32° C (60° F to 90° F) and a water outlet temperature not to exceed 43° C (110° F). If water cooler than 16° C (60° F) is used, high

 DANGER
Discharge air used for breathing will cause severe injury or death.
Consult filtration specialists for additional filtration and treatment equipment to meet health and safety standards.

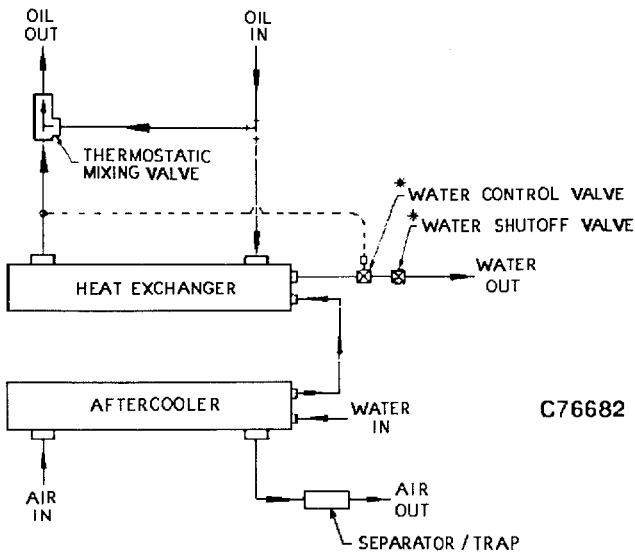

C76682

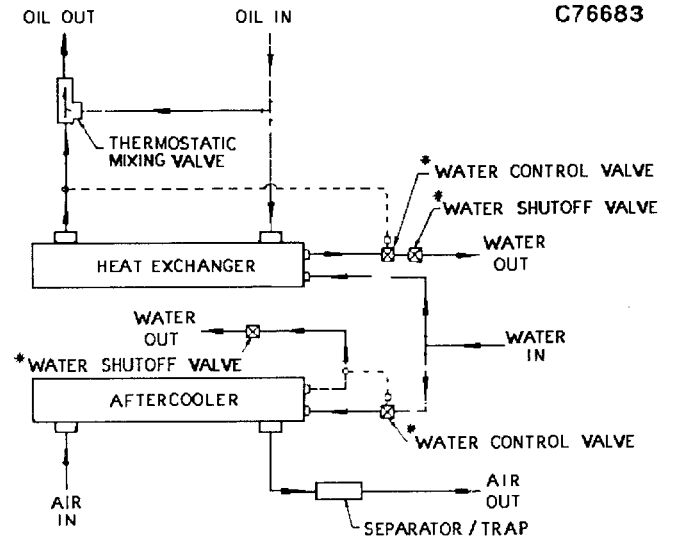

C76683

* (OPTIONAL) WATER CONTROL VALVE AND WATER SHUTOFF VALVE MUST BE ORDERED SEPARATELY.

FIGURE 2-5 - SERIES PIPING

FIGURE 2-6 - PARALLEL PIPING

water outlet temperatures (over 43° C, 110°F) will be experienced along with shortened heat exchanger life caused by tube fouling and corrosion. If water warmer than 32° C (90°F) is used, higher compressor oil inlet temperatures and high water usage will result.

Most water systems will require control of impurities: filtration, softening or other treatment. See "Compressor Oil Cooler - Water-Cooled Heat Exchanger," Section 5, pages 8 & 9, for more information on the water system.

SERIES PIPING (Figure 2-5) - Water flow must be through aftercooler first for effective cooling of discharge air and is so piped on the standard water-cooled unit.

PARALLEL PIPING (Figure 2-6) - A separate water control valve is required to control the discharge air temperature. If a remote (externally mounted) water-cooled aftercooler is piped in parallel with the heat exchanger, provide a separate water control valve for the aftercooler and pipe separate inlet water lines to both the aftercooler and the heat exchanger.

The water control valve is to be adjusted to maintain oil out of the heat exchanger within the 60° to 66° C (140° to 150° F) range regardless of inlet water flow or temperature as long as a minimum flow for a given temperature (Figure 2-4, page 4, this section) is met. See Section 5 for adjustment instructions and maximum allowable lubricant temperature.

ELECTRICAL WIRING - Standard Units - The Gardner-

Denver[®] Rotary Screw compressor is factory wired for all starter to motor and control connections for the voltage specified on the order. It is necessary only to connect the unit starter to the correct power supply. The standard unit is supplied with an open drip-proof motor, a NEMA 12 starter and control enclosure. See "Location" paragraph, page 1, this section, for distance to nearest obstruction on starter and control box sides of the unit.

Lower operating voltages (200/208) require that the unit starter be remote mounted since the starter is too large to be mounted within the control enclosure. If not supplied with the compressor unit, the starter is to be a size 6 full voltage non-reversing type in NEMA (CEMA) enclosure suitable for the environment, with two (2) rejection type control circuit fuses (size according to motor starter manufacturer's standard), a 200 (208) volt coil, and three (3) overload heaters for 200 (208) volt 100 HP, 1.15 service factor motor. The overload heaters are to be selected according to starter manufacturer's tables based on motor nameplate full load amperage.

⚠ WARNING

Electrical shock can cause injury or death. Open main disconnect switch, tag and lockout before working on starter/control box.

GROUNDING - Equipment must be grounded in accordance with the local Electrical Code.

⚠ WARNING

Failure to properly ground the compressor package could result in controller malfunction.

MOTOR LUBRICATION - Long time satisfactory operation of an electric motor depends in large measure on proper lubrication of the bearings. The charts on the next page show recommended grease qualities and regreasing intervals for ball bearing motors. For additional information, refer to the motor manufacturer's instructions. The following procedure should be used in regreasing:

1. Stop the unit.
2. Disconnect the unit, tag and lockout from the power supply.

grease.

4. Wipe lubrication fitting clean and add grease with a hand-operated grease gun.
5. Leave the relief plug temporarily off. Reconnect unit and run for about 20 minutes to expell the excess grease.
6. Stop the unit. Replace the relief plug.
7. Restart the unit.

⚠ WARNING

Rotating machinery can cause injury or death. Open main disconnect, tag and lockout power supply to starter before working on electric motor.

ELECTRIC MOTOR GREASE RECOMMENDATIONS

	Standard Service	High Temperature
Worked Penetration	265-296	220-240
Viscosity, SSU At 38° C (100°F).....	400-550	475-525
Soap Type	Lithium	Lithium
N-H Bomb, Min. Hours For 1.4 Bar (20 PSI) Drop at 99°C (210°F)..	750	1000
Bleeding, Maximum Weight % In 500 Hours 100°C (212°F)	10	3
Rust Inhibiting	Yes	Yes

3. Remove the relief plug and free hole of hardened

ELECTRIC MOTOR REGREASING INTERVAL

Type of Service	Typical Examples	Rating	Relubrication Interval
Standard	One- or Two-Shift Operation	112 KW & Below	18 Months
Severe	Continuous Operation	112 KW & Below	9 Months
Very Severe	Dirty Locations, High	112 KW & Below	4 Months

SECTION 3 STARTING & OPERATING PROCEDURES

PRESTART-UP INSTRUCTIONS - A new unit as received from the factory has been prepared for shipping only. Do not attempt to operate the unit until checked and serviced as follows:

1. **Compressor Oil** - Check oil level in the reservoir. Add oil only if the oil level gauge reads in the red "ADD OIL" range after rotating coupling several turns. Do not mix different type oils. The unit is shipped filled with Gardner-Denver AEON™ 9000 Lubricating Coolant which is suitable for the first 8000 hours under normal operating conditions.

REPLACE OIL FILTER EVERY 1000 HOURS.

Initial fill, or filling after a complete draining of the system, may show the oil level in the yellow "EXCESS OIL" range. After start-up, the oil will fall into the green operating range as system components are filled. If necessary, add oil to bring the level to the center of the green range as read when the unit is operating at full load and normal pressure. See Figure 5-5, Section 5, page 6.

NOTICE

Regular maintenance and replacement at required intervals of the oil filter, air filter and air-oil separator is necessary to achieve maximum service and extended drain intervals of AEON 9000 synthetic lubricant. Use only genuine Gardner-Denver filters designed and specified for this compressor.

DANGER

Always stop the unit and release air pressure before removing oil filler plug. Failure to release pressure may result in personal injury or death.

During unloaded operation and after shutdown, the system will partially drain back into the oil reservoir and the oil level may read higher than when operating on load. **DO NOT DRAIN OIL TO CORRECT;** on the next loaded cycle or start, oil will again fill the system and the gauge will indicate the operating level.

2. **Air Filter** - Inspect the air filter to be sure it is clean and tightly assembled. Refer to Section 6, "Air Filter," for complete servicing instructions. Be sure the inlet line, if used, is tight and clean.

3. **Coupling** - Check all bolts and cap screws for tightness. See Section 7.
4. **Piping** - Refer to Section 2, "Installation," and make sure piping meets all recommendations.
5. **Electrical** - Check the wiring diagrams furnished with the unit to be sure it is properly wired. See Section 4, "Controls and Instruments," for general wiring diagrams and Section 2 for installation instructions.
6. **Grounding** - Unit must be properly grounded according to the local Electrical Code.

WARNING

Failure to properly ground the compressor package could result in controller malfunction.

7. **Rotation** - Compressor drive shaft rotation must be clockwise standing facing the compressor at the coupling end. See Auto Sentry Set-up instructions, Step 24, page 8, Section 4, for jogging the motor.

WARNING

Operation with incorrect motor rotation can damage equipment and cause oil eruption from the compressor inlet. When checking motor rotation, induce minimum rotation (less than one revolution if possible). Never allow motor to reach full speed.

8. **System Pressure** - Set the controls to the desired unload pressure and differential. **DO NOT EXCEED MAXIMUM OPERATING PRESSURE ON COMPRESSOR NAMEPLATE.** See Section 4, "Controls and Instruments," for procedure.

WARNING

Operation at excessive discharge air pressure can cause personal injury or damage to equipment. Do not adjust the full discharge air pressure above the maximum stamped on the unit nameplate.

9. **Operating Mode** - Refer to Section 4 for detailed information on the control system.

10. **Enclosure** - Check for damaged panels or doors. Check all screws and latches for tightness. Be sure doors are closed and latched.

STARTING THE UNIT - OBSERVE UNIT COLD OR HOT STARTING PROCEDURES

Unit Cold - If the unit is a water-cooled heat exchanger model, open any manual water inlet valves wide open. Start the unit by pushing either the "CONSTANT RUN" button or one of the "AUTO" buttons. Since the unit is equipped with a minimum (4.5 Bars, 65 psig) pressure discharge valve, no special procedure to maintain unit reservoir pressure is required.

Unit Hot - No warm-up period is required. If the unit is a water-cooled heat exchanger model, open any manual water inlet valves wide open. Start the unit by pushing either the "CONSTANT RUN" button or one of the "AUTO" buttons.

DAILY CHECK - Refer to Section 8, "Maintenance Schedule."

STOPPING THE UNIT - Press "STOP-RESET" button. The oil reservoir will automatically blow down as the motor stops. If the unit is a water-cooled heat exchanger type, close any manual water inlet valves.

SEQUENCING COMPRESSORS

Sequencing compressors with the **AUTO SENTRY-ES** controller is as simple as plugging in a telephone to a wall jack. The only item required to make the system functional is a standard telephone cable identical to cables that connect nearly every telephone to its wall jack. One less cable than the number of compressors to be sequenced is required. For example, to sequence four compressors, three cables are required. A kit, 200EAP752, is available which contains all material needed to sequence up to five compressors. This kit contains 150 M (500 feet) of cable, eight modular connectors and a crimping tool to install the connectors.

Even with its inherent installation simplicity and the fact that it is a standard feature, the sequencing function of a multi-compressor "**AUTO SENTRY-ES**" system is the most fully-featured, functionally-complete available today.

I. INSTALLATION

A proper sequencing installation requires two or more Gardner-Denver rotary air compressors complete with "AUTO SENTRY-ES" controllers, piped into a common air system, interconnected as described above. All standard practices common to sound air compressor installations such as proper sizing of discharge piping, proper electrical supply and conductor sizing, and grounding are to be observed. The serial communications interface meets RS-485 standards, the most widely used interface in harsh, industrial environments today. However it is still recommended that the communications cables be routed through metallic conduit to provide them with both mechanical protection and electromagnetic shielding.

Each control circuit board has two modular jacks which accept standard RJ-12 telephone plugs. One jack is vacant; the other has a short pigtail plugged into it. To interconnect two compressors, plug the cable into the vacant jack on each controller. For installations of more than two units, the pigtail plug must be disconnected on all controllers except the two at each end of the communications line. The order of interconnection has no effect

on the system operation. The following conditions are necessary and sufficient for proper operation:

1. Every compressor must have a cable connecting it to another compressor. One less cable than the number of units sequenced, must be used.
2. Each board that has only one cable connected to it must have its pigtail plugged into the unused jack. All installations will have two such units.

II. OPERATION

A. ESTABLISHING THE INITIAL SEQUENCE

Operation of compressors in sequence requires only a press of the 'sequence' key on each compressor in the system. Since the sequencing algorithm includes provisions for automatic replacement of a failed master or 'lead' compressor, it is important for the operator to be aware of the hierarchy of events when starting the system.

The first compressor placed in sequence mode will become the master. However, since any compressor first placed in sequence has no way of knowing whether or not a master exists, it will first assume the highest rotation number available. For example if the number of units to be sequenced is programmed at four, any compressor will start out in position four when placed in sequence mode. It will then listen on the communications line for a call from the master.

If no call is received, it will assume position three and again wait for a call from the master. After another lack of master call, it assumes position two. Subsequently, it assumes position one which makes it the master. As soon as a master is established, it immediately attempts to call all other units and assigns them successive rotation positions. The system is now active.

Before a master is established, the system is not deprived of air. This is due to one of the outstanding features of the "**AUTO SENTRY-ES**" sequencing system: pressure control is always executed locally at each individual compressor. The effective setpoint for com-

pressor control is the programmed setpoint minus 3(rotation number - 1). So while a compressor (or compressors) is/are counting down towards establishing a master, they are also capable of delivering air at a pressure determined by the above formula.

To insure that two or more machines do not simultaneously decrement their rotation numbers and simultaneously become masters, it is advisable to place the desired master in sequence mode first and wait until the first decrement in rotation number is seen (about 7 seconds) before placing subsequent compressors in sequence mode. If it is desired to dictate the complete initial sequence manually, wait until the previous machine decrements one position and then place the next desired compressor in sequence mode. If it is acceptable to let the master determine the initial sequence, simply wait until the master has decremented its rotation number once, and then place all remaining compressors in sequence mode. Remember that once a master is established, no further self-decrementing is done by the individual compressors. Instead, they will wait until the master assigns them a rotation number.

Rotation numbers are displayed in the bottom display line, with the mode indication. For example, the mode indication for the current master is **SEQ1**; for the first lag compressor, **SEQ2**; second lag **SEQ3**, etc.

B. HOW THE "AUTO SENTRY-ES" CONTROLS PRESSURE WHILE SEQUENCING

Each compressor operates exactly the same as if it were in AUTO mode with one exception: it has a dynamic setpoint. The initial setpoint is determined by the equation shown above. A compressor is started when the system pressure drops below its programmed reset point, after waiting for ['LAG START INTERVAL' times (rotation number - 1)] seconds. This prevents all lag compressors from starting at once. Note that a compressor's ['LAG START INTERVAL' times (rotation number 1)] timer is not reset to zero until that compressor is started. This means that the time for the next lag compressor to come on is always somewhat less than 'LAG START INTERVAL'.

NOTICE

To maintain accuracy, the controller must be programmed in "PSI" mode. If machine is to be operated in "BARS" mode, set up the sequencing in "PSI" mode and then change the operating mode to "BARS."

EXAMPLE:

In a three compressor sequence system, SET PRESSURE = 100 PSI; RESET PRESSURE = 90 PSI; LAG START INTERVAL = 15 seconds. The lead compressor is running alone, maintaining 100 PSI by modulation

when an air tool is brought on line causing the air demand to exceed the capacity of the lead compressor. When the pressure drops to 90 PSI, the #2 unit times out its 15 second timer and starts. It takes 5 additional seconds for the pressure to rise above 90 PSI. The #3 unit whose timer was initially set at 30 seconds ($15 \times [3 - 1]$), has counted down 20 seconds (the total time that system pressure was below 90 PSI). If air demand increases again, the pressure will have to fall below 90 PSI for only 10 seconds more to start unit #3.

As was previously stated, a lag compressor's modulation setpoint (PSET for short) is [SET PRESSURE - 3(rotation number - 1)]. Thus in the above example, the first lag compressor (rotation #2) has a PSET of 97 PSI; the second lag, 94 PSI, and so on. But look what happens in an eight compressor installation: The eighth compressor will have an initial setpoint of $[100 - 3(8 - 1)]$, or 79 PSI. Does this mean that an eight compressor installation must operate 21 PSI below the desired operating point when all compressors are running? NO! This is where the "AUTO SENTRY-ES" dynamic setpoint control takes over. This is how it works: Whenever the system pressure is below the programmed RESET PRESSURE, the PSET of each lag compressor is incremented 1 PSI every thirty seconds. Thus, after a short interval (about five minutes in this example), the PSET of the last sequenced compressor will climb up until either it equals the RESET PRESSURE, or a decrease in demand causes the actual system pressure to rise above the RESET PRESSURE. It can be seen then, that except for short periods just after a sudden increase in demand, the "AUTO SENTRY-ES", with its dynamic setpoint control, will maintain system pressure between the limits of RESET PRESSURE and SET PRESSURE. Remember, RESET and SET PRESSURE values are programmed by the operator so the operating range is completely programmable and predictable.

Dynamic setpoint control will also work in reverse of the operation described above. Obviously, incrementing setpoints will cause overlap of the compressors' modulation ranges. While this enables us to maintain a higher pressure than competitor's sequencers, overlap is undesirable as demand decreases, because a system could end up with several compressors running partially loaded instead of running the minimum number of fully loaded compressors. To overcome this, as pressure rises through the range between RESET and SET, the lag compressors' PSET's are now decremented, reversing the effect described above during periods of high demand. - The "AUTO SENTRY-ES" keeps track of all functions at all times so there is never any mix-up of setpoints and the proper rotation sequence is always maintained.

III. THE AUTOMATIC SEQUENCE CHANGE

After the master (lead) compressor has served for the duration programmed (TRANSFER INTERVAL), it relinquishes control and assigns itself the highest available rotation number. The lag compressors detect the loss of

the master and decrement their rotation numbers. Number 2 becomes number 1, the new master, number 3 becomes number 2, etc.

It should be noted also that whenever the master detects a missing rotation number, such as when a compressor is turned off that was previously in the rotation, it will automatically 'close the gap' by decrementing the rotation numbers of all compressors whose rotation numbers were greater than the missing number. Likewise, if for whatever reason, the master compressor fails to carry out its role, all lag compressors begin decrementing their rotation number until a new master is established. Regardless of the scenario, the end result will always be that the compressors that remain in rotation will always end up with the lowest possible rotation numbers.

IV. OTHER FEATURES

Any air system will exhibit pressure differences from one point to the next. Even a well designed multi-compressor installation will show 'minor' pressure variations between one compressor's discharge point and another compressor's discharge. These points will also vary with the central system (normally the air storage receiver). These pressure differences wreak havoc with conventional sequencers. If a central sequencer is used, it will be sensing a lower pressure than is seen at each compressor. With such systems, there is always a chance that the sequencer could cause a compressor to over pressure due to this pressure drop. The alternative has been to set the control sequencer to a lower pressure to prevent this or allow local override of the sequencer by the local pressure control, neither of which is desirable

in the scheme of maintaining plant pressure efficiently with sequencing.

The "**AUTO SENTRY-ES**" sequencing system lets each compressor control itself independently about a setpoint (PSET) derived to cause staggered operation, or sequencing. The aforementioned pressure drops can also cause derogatory effects (mainly skewed, or out of sequence operation) to the sequencing algorithm used by the "**AUTO SENTRY-ES**".

Since these pressure variations are not constant (they will vary due to demand changes, compressor load percentage changes, and number of compressors running), any scheme to compensate for the pressure variations must be dynamic. That is, corrections must be applied rather frequently, and on the fly. The exclusive dynamic setpoint control feature enables this error correction scheme to be accomplished rather easily.

Here's how it works: The master continually receives system pressure values from every machine in the sequence rotation. The values are averaged and this average is then distributed to all lag compressors. This happens approximately once per second. All compressors, lead and lag, then compare their local pressure reading to the average and adjust their PSET by the amount of error. The effect is that all compressors are controlling to a single pressure reading, a reading that is not one that is picked up somewhere removed from the compressor, but an average of actual discharge pressures.

It should be noted that the pressure displayed on the top line by all sequenced compressors is this average.

SECTION 4 - EBQ UNITS CONTROLS & INSTRUMENTS

GENERAL DESCRIPTION - The Gardner-Denver Rotary Screw compressor is prewired with all controls, motor and wiring, and starter for the voltage and horsepower specified at the time of the order. It is necessary only to connect the compressor unit to the correct power supply, to the shop air line, and to the shop water line, if the compressor is watercooled. A standard compressor unit consists of the compressor, oil reservoir, oil cooling system and oil filters, motor enclosure specified, NEMA 12 starter/control box, and controls as described below.

This compressor features the programmable control, which integrates all the control functions under micro-processor control. Its functions include safety and shutdown, compressor regulation, operator control, and advisory/maintenance indicators. The keypad and display provide the operator with a logical and easily operated control of the compressor and indication of its condition.

PROTECTIVE DEVICES AND SHUTDOWN - The "Auto Sentry-ES" will shut down the unit following any fault detected in the following devices. Following a shutdown, a message will be displayed to indicate the cause. The shutdown light will be on if the cause still exists, or will flash if the cause has been cleared. To resume operation, the cause of shutdown must be corrected and the controller reset by pressing the "STOP/RESET" key.

Motor Protection Devices - Overload heaters are furnished for the starter in the voltage range specified. There are three (3) overloads in the starter of proper size for the starter and its enclosure. Note that motor nameplate current must be multiplied by .577 for wye-delta starters. The display will indicate which overload relay tripped. The overload relay is reset by pressing the button on the relay itself. Motor current (amps) and voltage must be measured to locate the cause for high current. Proper starter coil and contact action is also monitored and errors in operation will cause a shutdown with the cause displayed.

High Temperature - The compressor is protected from high discharge and separator temperature by two independent thermistor probes. One probe is located in the discharge housing to sense the compressor discharge air-oil mixture temperature. The second probe is located at the separator discharge and senses the temperature of the air at the oil separator. The "Auto Sentry-ES" will shut the compressor down if temperature sensed at either location exceeds 107° C (225° F.) (or lower per user adjustment) or if a rapid temperature rise is detected. The location of the high temperature will be displayed. Shutdown will also occur if a shorted probe, open probe, or extreme low temperature is detected. The display will indicate the location of the defective thermistor probe.

CAUTION

Machine damage will occur if compressor is repeatedly restarted after high temperature stops operation. Find and correct the malfunction before resuming operation.

Separator Differential Pressure - The separator differential pressure is continually monitored by the "Auto Sentry-ES". At a differential pressure of approximately 1 Bar (15 psi), the unit will be shut down.

High Pressure - The "Auto Sentry-ES" will shut down the unit if excessive pressures are detected in the reservoir or system. Shut down will also occur if a defective transducer is detected. The display will indicate the location of the high sensed pressure or transducer (xducer) error. Check that all adjustments have been made, and all connections are secure.

Relief Valve - A pressure relief valve(s) is (are) installed in the final discharge line and set to approximately 120% of the unit's full load operating pressure for protection against overpressure. Periodic checks should be made to ensure its (their) proper operation.

The relief valves should be tested for proper operation at least once every year. To test the relief valve, raise the system operating pressure to 75% of relief valve set pressure and manually open the valve with the hand lever. Hold the valve open for a few seconds and allow it to snap shut.

WARNING

When relief valve opens, a stream of high velocity air is released, resulting in a high noise level and possible discharge of accumulated dirt or other debris. Always wear eye and ear protection and stand clear of the discharge port when testing the relief valve to prevent injury.

CAUTION

Never paint, lubricate or alter a relief valve. Do not plug vent or restrict discharge.

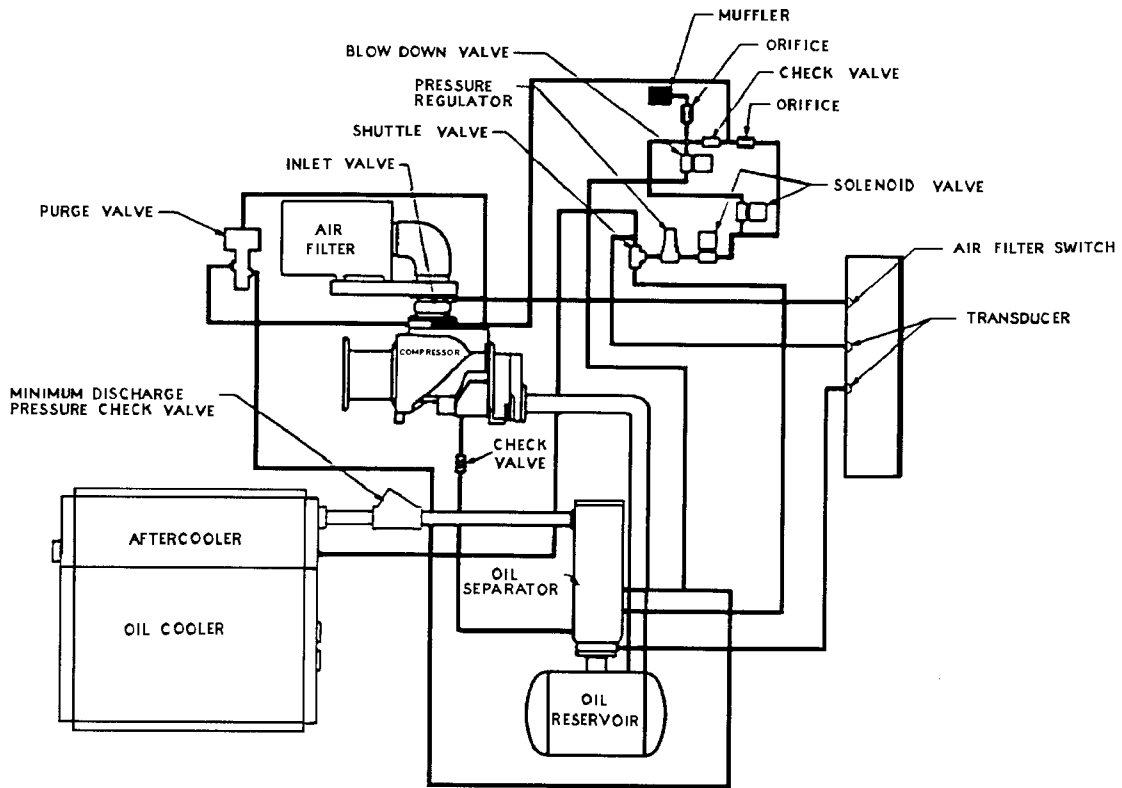



FIGURE 4-1 - SCHEMATIC TUBING DIAGRAM

 WARNING
<p>Operation of unit with improper relief valve setting can result in severe personal injury or machine damage.</p> <p>Ensure properly set valves are installed and maintained.</p>

Low Oil Pressure - The programmable controller will shut down the unit if inadequate oil pressure to the compressor is detected. If this occurs, check the wiring and piping to the solenoid valves.

Emergency Stop - Pressing the emergency stop button will shut down the unit and the controller. To restart, pull the button out to its normal position and reset the controller.

Power Failure - Following power interruptions, the controller will remain in a shutdown state.

High Vibration (optional) - This optional feature will shut down the unit if abnormally high vibration is detected.

CHECK CN 7 (8, 9) - This indicates a wiring error or connection problem. Remove power and correct all wiring

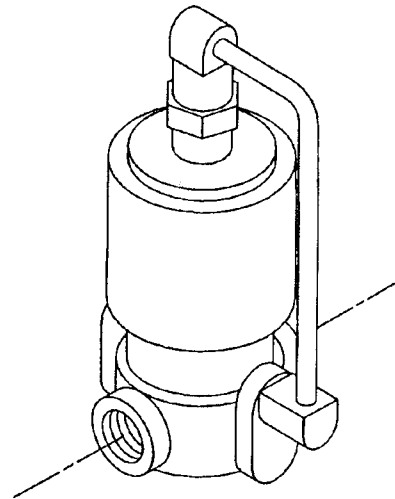

FIGURE 4-2 - BLOWDOWN VALVE

NOTICE
<p>To restart the compressor after any shutdown, perform the necessary service, press STOP/RESET and choose a run mode.</p>

Blowdown Valve -The blowdown solenoid valve re-

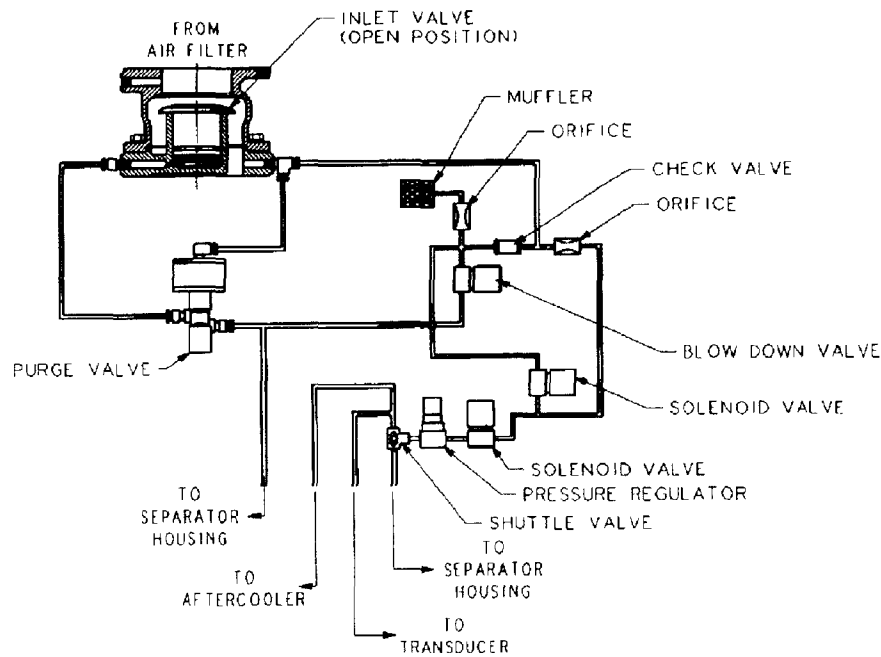

FIGURE 4-3 - INLET VALVE

leases pressure from the oil reservoir during any shut-down condition, and during some operating conditions. See Figure 4-2, page 2, this section, and description under "Air Control Components" in this section for construction and operation information.

GAUGES AND DISPLAYS

Oil Level - The oil level gauge is located on the side of the reservoir. See Section 5, page 6, "Oil Level Gauges" for information on how to correctly read the gauge. All other instruments are part of the programmable controller.

AIR CONTROL COMPONENTS - Refer to Figures 4-1, 4-6, 4-7 and 4-8, pages 2, 9, 10 & 11, this section, for schematic tubing diagrams.

Inlet Valve (Figure 3-4) - The inlet valve restricts the inlet to control capacity and closes to unload the compressor. At shutdown, the inlet valve closes to prevent back-flow of air.

The inlet valve position is controlled by air pressure in its piston cylinder, which is controlled by the "Auto Sentry-ES" through solenoid valves IVC and IVO. As pressure to the piston is increased, the valve closes to restrict air flow and compressor delivery (Figures 4-6, 4-7 and 4-8, pages 9, 10 & 11, this section).

Minimum Discharge Pressure Valve (Figures 4-4, and 1-5, Section 1, page 3) - An internal spring-loaded minimum pressure valve is used in the final discharge line to provide a positive pressure on the oil system of the compressor even when the air service valve is fully open.

The valve incorporates an orifice which, when air is flowing through it, maintains approximately 4.5 Bars (65

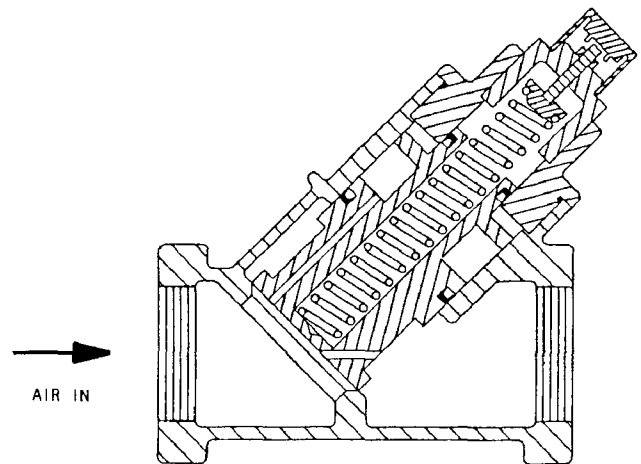

FIGURE 4-4 - MINIMUM DISCHARGE PRESSURE VALVE

psig) in the oil reservoir. A spring-loaded piston valve senses air pressure on the upstream (oil reservoir side) of the valve. When the system pressure rises above 4.5 Bars (65 psig), the spring is overridden and the valve opens to full porting.

The valve does not require maintenance or adjustment. If the valve fails to function, check the valve stem O-ring for sealing, valve orifices for restriction, or valve and valve seat for burrs and dirt.

The valve is adjustable within a small range. It is adjusted by a screw on the side of the valve body. The minimum pressure can be adjusted as follows:

1. Start the compressor.
2. Reduce pressure downstream of minimum pres-

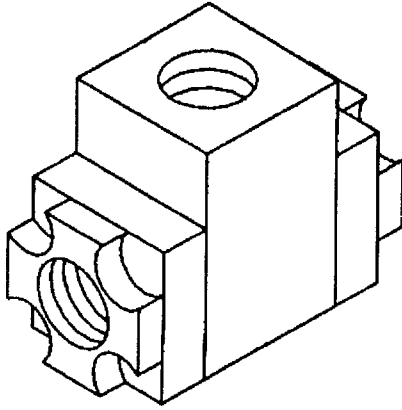

FIGURE 4-5 - SHUTTLE VALVE

sure valve to below desired minimum pressure. DO NOT REDUCE UPSTREAM PRESSURE OR ADJUST VALVE BELOW 4.5 BARS (65 PSIG).

3. Loosen locknut on adjusting screw.
4. Turn set screws in to increase, or out to decrease minimum pressure to be held.
5. Hold set screw at desired point and tighten locknut.

Check Valve (Oil Reservoir) - A renewable seat swing type check valve in the final discharge manifold prevents backflow of air from the shop air line when the unit stops, unloads or is shut down.

Purge Air Valve - The purge valve is a normally closed two-way air actuated valve that admits purge air from the final discharge manifold to the compressor to counteract the oil knock which occurs in oil-flooded rotary screw compressors when they are completely unloaded with pressure in the oil reservoir. This valve is controlled by the same control pressure which controls the inlet valve.

Solenoid Valves IVC and IVO - These valves control position of the inlet valve in response to signals from the "Auto Sentry-ES". With both valves de-energized, the normally open IVC valve allows control pressure to the inlet valve piston to close the valve. If IVC only is energized, the inlet valve is held in its current position. If both valves are energized, control pressure is relieved from the inlet valve piston to allow the valve to open.

Pressure Regulator - The pressure regulator is used to supply a constant and low control pressure to prevent damage to the inlet valve from "slamming." The regulator should be set for 1.7 to 2.1 Bars (25 to 30 psig).

Shuttle Valve - (Figure 4-5) Also known as a double check valve, the shuttle valve is a device which will take two (2) supply signals and allow the one with the highest pressure to pass through. The shuttle valve is used to provide control air pressure from either the reservoir or plant air system, as required during different operating

conditions.

Blowdown Valve - (Figure 4-2, Section 4, page 2) The blowdown valve is a two-way solenoid valve which is piped into the oil reservoir outlet but ahead of the check valve. When the solenoid is de-energized, the valve opens and the oil system is blown down. When the solenoid is energized, the valve closes to allow the oil system to pressurize. A control air check valve is provided to ensure that the inlet valve closes during blowdown. See Figure 4-6, Section 4, page 9.

System Pressure Transducer - This transducer is connected after the minimum pressure valve and discharge check valve. It converts the pressure in the plant air system to an electrical signal for use by the programmable controller for modulation and control.

Reservoir Pressure Transducer - This transducer is connected to the oil reservoir. Its signal is used to prevent loaded starts, monitor oil pressure, and for separator differential.

Air Filter Vacuum Switch - This switch is used to monitor air filter condition and alert the user if the filter requires service or replacement.

Vibration Switch (Optional Equipment) - The optional vibration shutdown switch, mounted on the compressor coupling cover, detects an increase in vibration that could be an indication of impending damage to the unit. The switch actuates when the selected level of vibration is exceeded.

The switch MUST BE ADJUSTED when the unit is first installed. Refer to switch manufacturer's instruction manual for complete details.

STARTER/CONTROL PANEL

The following items are located in the electrical enclosure and provide the main control of the compressor unit and switching of the motor(s). Refer to Figure 1-3, Section 1, page 2.

AUTO SENTRY-ES CONTROLLER - The "Auto Sentry-ES" is located on the upper section of the panel. It provides all the control of the motors and control devices for safe and efficient operation of the compressor unit. Its display provides all gauging functions, shutdown causes, and maintenance recommendations. The keypad provides the user with selection of operating modes and adjustment to tune the controls for the application. It is connected to other devices inside the panel and external devices through the terminal strip. The "Auto Sentry-ES" requires no maintenance.

Emergency Stop - This is a maintained pushbutton, and removes power from the controller outputs regardless of controller status. It is located on the upper section of the panel, next to the keypad.

 **WARNING**

Automatic restarting or electrical shock can cause injury or death. Open and lock main disconnect and any other circuits before servicing unit.

Control Transformer - This changes the incoming power voltage to 110/120 volts for use by all unit control devices. Two primary and one secondary fuse are provided. Refer to the adjacent labelling for replacement information.

Terminal Strip - This provides connections for all 110/120 volt devices not contained within the control panel.

Fan Starter - (where applicable) The starter is used to provide control and overload protection for the cooling fan on air-cooled units and ventilation fans of watercooled units with enclosure. Overload heaters should be selected based on the nameplate current of the fan motor. Three fuses are provided. Refer to adjacent labelling for replacement information.

Main Starter - This starter is used to provide control and overload protection for the main drive motor. For wye-delta starters, overload heaters should be selected based on the motor nameplate current times .577 for proper protection. Wye-delta starters employ three contactors which are controlled sequentially to provide low current starting. Full-voltage starters employ a single contactor; overload selection should be based on the full load current of the motor, and adjacent labelling.

OPERATION

Operation of the AUTO SENTRY-ES Controller is dependent on selection of an operating mode from the controller keypad. Prior to starting, the "STOP/RESET" key must be pressed to place the control in its ready state. Operation may then be started by selecting an operating mode from the controller keypad. Once operating, the operating mode may be changed at any time. The STOP/RESET key may be pressed at any time to stop the compressor under normal conditions.

An optional control may be wired to the control to interrupt and restart the unit based on controls by others. When stopped by these controls, the display will indicate "REMOTE STOP."

 **WARNING**

Automatic restarting or electrical shock can cause injury or death. Open and lock main disconnect and any other circuits before servicing unit.

In any mode, the compressor will start only if reservoir pressure is below .3 Bar (5 psig). The display will indicate if the control is waiting for blowdown. The controls will keep the compressor unloaded until the start cycle has been completed.

Constant Run Mode Operation - This mode is best used in applications where there are no long periods of unloaded operation. The compressor unit will start and run continuously, using its modulation controls to match delivery to demand.

As demand falls below the compressor capacity, the pressure will rise to the setpoint of the control. When the pressure reaches the setpoint the AUTO SENTRY-ES controller operates the solenoid valves to pass pressure to the inlet valve piston and the inlet valve closes enough to match air system demand. See Figure 4-6, Section 4, page 9.

As demand increases, the controller will modulate the inlet valve by passing pressure with the solenoid valves as required to provide the most economical means of matching delivery to demand. See Figure 4-7, Section 4, page 10.

Low Demand Mode Operation - The low demand mode reduces power consumption by relieving pressure in the reservoir during unloaded operation. Under loaded conditions, it will operate identically to the constant-run mode described above.

During low demand periods, the controller will open the blowdown valve and fully close the inlet valve to minimize the motor load. See Figure 4-8, Section 4, page 11. A timer is started when this occurs. While in this state, control air pressure is supplied from the plant air system. When system air pressure drops due to increased demand, the blowdown valve recloses and the controls resume their normal modulation sequence.

Subsequent blowdown periods are not allowed until the timer has completed its cycle. This cycle eliminates the problems of oil foaming and carryover which can occur if the oil reservoir of an oil-flooded compressor is blown down too often. The timer is adjustable from 5 to 20 minutes.

Automatic Mode Operation - This mode provides automatic start and timed stop, and is best used in applications with long unloaded periods (1 hour or longer). Operation during periods of demand or moderately long unloaded periods is identical to the low demand mode.

The Auto time delay is adjustable from 5 to 30 minutes. If the controller operates unloaded for this period with no demand, the compressor drive motor is halted to eliminate its power consumption. The controls will remain in this state until demand is again indicated by a drop in pressure.

Sequence Mode Operation - This mode provides for communication between controllers, operating only as many as are required for economical operation. The lead unit operates identically to the automatic mode; opera-

tion will be automatically staged for each lag unit.

Communication between controllers is achieved by interconnection of a communications link to circuit board connectors. A "unit number" must be assigned to each unit to operate in this mode (see "Programming and Setup" in this section). For complete information on sequencing compressors, see Section 3, page 2.

CONTROLLER DISPLAY

The display above the keypad is used to provide operating information to the user. If a shutdown has occurred, the display will indicate the cause as noted above.

During normal operation the display will show the operation mode, system pressure, compressor discharge temperature, and total running hours. Alternate displays are available by pressing keypad cursor keys, and will be identified on the display. These include reservoir pressure, separator differential pressure, reservoir temperature, system pressure, and compressor discharge temperature. In Low Demand, Automatic, and Sequence modes, alternate displays also indicate remaining times of delays. If no keys are pressed for 5 seconds, the display will return to its normal mode.

The display is also used as a service reminder for normal maintenance items. These include the separator, air filter, and oil filter change intervals. All intervals are based on recommended parts as noted in the maintenance section of this manual. Oil change intervals are also automatically calculated, based on actual operating conditions. This allows maximum utilization of AEON 9000 oil. Messages will also be displayed if operation has occurred during low ambient temperatures, or if high temperature operation has occurred.

Clearing Advisories - Temperature advisories may be cleared while the unit is running by simply pressing the ENTER key. To reset the service messages, press the STOP/RESET key to stop operation of the compressor. Disconnect power and service the unit as required. Following service, put the enable switch in the down position, restore power to the unit, and press STOP/RESET to clear the controller. Proceed through the service section described in step 1 below. Active advisories will be displayed and may be cleared by pressing the ENTER key. After the messages have been cleared, press STOP/RESET and select an operating mode to resume operation.

PROGRAMMING AND SETUP INSTRUCTIONS FOR THE AUTO SENTRY-ES (R) CONTROLLER

Programming and setup is accomplished with the "PROGRAM" keys. In all steps, the "ENTER" key will cause the controller to accept the displayed value into memory and advance to the next programming function. The plus "+" and minus "-" keys will increase and decrease displayed values, respectively. The right and left arrow keys, "→" and "←", position the cursor (flashing digit). The number at the cursor will be the number that is

changed by the "+" and "-" keys. At any point in the programming and setup routine, the "STOP-RESET" key can be pressed to exit and return to the ready mode.

In all steps of the programming routine, the top line of the display will give a description of the parameter to be programmed, while the bottom line shows the variable that is capable of being altered by programming.

The following is a step by step guide to programming the "AUTO SENTRY-ES" Controller.

NOTICE

Between each step it is necessary to press the "ENTER" key to store the new value and advance to the next step.

1. Press the "ENTER" key to begin programming. If the enable switch on the circuit board is in the set position, the control proceeds to the setup adjustments starting with step 2 below. If the slide switch is down in the "+" position, push "ENTER" to go from OIL FILTER CHANGE to OIL CHANGE and then push "ENTER" again to go proceed to Step 2. Press "AUTO" to display the hours remaining until oil change or filter change is recommended. If service has been performed early, press the "AUTO" key to reset the timers to their full number of hours. Press "ENTER" to proceed to the next display without affecting timers.
2. In the top line, **DISPLAY UNITS** is indicated. The bottom line will indicate ENGLISH (PSIG, Fahrenheit) or METRIC (Bars, Celsius). Select the desired mode and press ENTER to save and proceed.
3. In the top line, **NUM OF SEQ UNITS** is displayed. The bottom line will indicate a number in the range of one through eight. This will be factory set at "1". This should be set to a number corresponding to the number of compressors that are currently installed on this air system that also have AUTO SENTRY-ES controllers. It should be noted that all AUTO SENTRY-ES compressors on the system must have the same number programmed here to operate correctly in "SEQUENCE" mode.

NOTICE

Setting the value in step 3 to one indicates that no sequencing is to take place. Consequently, steps 4, 5, and 6, which relate to sequencing, are skipped by the "AUTO SENTRY-ES"; Programming commences at step 7.

- In the top line, **UNIT NUMBER** is displayed. The bottom line will again indicate a number of one through eight. This will be factory set at "1". Each "AUTO SENTRY-ES" in a sequenced system must have a unique number here. The sequence mode will not function if two or more compressors have the same **UNIT NUMBER**.

Most efficient machine-to-machine communications will occur when the lowest possible numbers are used. Example: 1, 2, and 3 for a three compressor installation.

- In the top line, **TRANSFER INTERVAL** is displayed. The bottom line will indicate a number of hours in the range of 1 to 5000. It is factory set at 24. This is the number of hours that this machine will stay in the role of "master" or "lead" compressor. Normally it is desirable to set this value the same on all sequenced units to equalize the running hours.
- In the top line, **LAG START DELAY** is displayed. The bottom line will indicate a number in the range of 15 to 600 seconds. It is factory set at 30. This number is the length of time this machine will wait before starting when the pressure drops below the reset point. Again, this is normally set to the same value for all the sequenced units. It's setting will depend on the amount of air storage volume in the system.
- In the top line, **BLOWDOWN TIME** is displayed. The bottom line will indicate a time between 5 and 20 minutes. It is factory set at 10 minutes. This is the minimum time interval between blowdowns.

Limiting the blowdown frequency has been shown to prevent oil foaming and minimize wasteful dumping of compressed air when loading is likely to occur in a short time.
- In the top line, **AUTO TIME** is displayed. The bottom line will indicate a time between 5 and 30 minutes. It too, is factory set at 10 minutes. Its function is to prevent too frequent motor starting, and to allow the motor a 'cool-down' period before stopping.
- In the top line, **START TIME** is displayed. The bottom line will indicate a time between 3 and 10 seconds. This is the time that the wye-delta starter spends in the 'start' mode. It should be set to transfer the starter to the 'run' mode as soon as the motor reaches its maximum attainable speed in the 'start' mode. If the set switch is off, the control returns to the "READY" state and may then be restarted.

NOTICE

This concludes operator accessible adjustments. The following are considered 'service adjustments'. The enable slide switch on the circuit board must be up in the "+" position to proceed to the next set of programmable adjustments. The "SET" switch is located beneath the power transformer mounting plate on the left edge of the main circuit board.

- In the top line, **HY SYS PRES LIM** is displayed. This should be set 1.4 to 1.7 Bars (20 to 25 PSI) above nameplate pressure (equal to the relief valve setting). If this pressure is approached, the control will be forced to a blowdown and shutdown condition.
- In the top line, **SET PRESSURE** is displayed. The bottom line will indicate a pressure value in the range of 3.4 to 12.4 Bars (50 to 180 PSI). It is to be set at the nameplate rating of the compressor for normal operation. Under NO circumstances, is this adjustment to be set in excess of the compressor nameplate pressure.
- In the top line, **RESET PRESSURE** is displayed. The bottom line will indicate a pressure value in the range of 3.1 to 12.1 Bars (5 to 175 PSI). This setting determines the point at which machine startup occurs in AUTO and SEQUENCE modes and when the compressor will load up from the blown down condition. Note that RESET PRESSURE cannot be set within .3 Bars (5 PSI) of the SET PRESSURE. It is necessary that all machines to be sequenced have the same SET and RESET PRESSURE setpoints.
- The top line displays **REMOTE STOP**. Select either IMMEDIATE or TIMED STOP as the desired response to the remote input.
- In the top line, **FILTER CHNG INT** is displayed. The bottom line will indicate a time interval of 1000 hours. This may be adjusted lower (down to 500 hours) if severe operating conditions are anticipated. After the machine has run for the programmed setting, an advisory will be displayed requesting an oil filter change.
- In the top line, **OIL CHNG INTERVAL** is displayed. The bottom line will indicate a time interval of 8000 hours. 8000 hours is the maximum setting, and is the proper change interval for AEON 9000 synthetic oil.
- In the top line, **HI TEMP LIMIT** is displayed. The bottom line will indicate 107° C (225° F). This is the

maximum (and proper) setting for compressor operation. It may be temporarily lowered to verify the function of the temperature shutdown system.

17. In the top line, **FAN TYPE** is displayed. The bottom line will indicate either **AIR COOLED** or **WATER COOLED**. Selecting **AIR COOLED** places the fan under thermostatic control while **WATER COOLED** operation runs the fan whenever the main motor runs.
18. In the top line, **AUTO RESTART** is displayed. The bottom line will indicate either **OFF** or **ON**. Set this feature to **ON** when it is necessary to have the compressor automatically restart after a power interruption. This feature shall only be enabled when the owner determines that it is safe to do so. It is recommended that compressor access be limited to only trained service personnel when this feature is enabled.
19. This step is only encountered if the **AUTO RESTART** function was set to **ON** in Step 18. In the top line, **RESTART TIME** is displayed. The bottom line will indicate a time between 5 and 60 seconds. It is factory set at 10 seconds. This is the amount of delay introduced before restarting after power has been restored.
20. In the top line, **AIR END TYPE** is displayed. The bottom line will indicate either **TURNVALVE** or **NON TURNVALVE**. It is to be set as is appropriate for the compressor.
21. In the top line, **SYSTEM VOLUME** is displayed. The bottom line may be selected as **SMALL**, **MEDIUM**, or **LARGE**. This tunes the response of the modulation control loops to optimize loop stability. It is factory set to **MEDIUM**. Set as follows:

SMALL if the estimated volume is less than 33 liters per M^3/min . (.25 gallon per CFM).

MEDIUM if the estimated volume is between 33 and 134 liters per M^3/min (.25 and 1 gallon per CFM).

LARGE if the estimated volume is greater than 134 liters per M^3/min . (1 gallon per CFM).

NOTICE

The setting of this parameter is not critical. When set to its most appropriate value, the controller will maintain the discharge at the closest possible value. If not set correctly, pressure will vary from the desired setpoint to a somewhat greater degree but the compressor and its components will not be adversely affected.

22. In the top line, **REMOVE SYS PRESS** is displayed. The bottom line displays the current pressure being sensed at the package discharge. At this point steps must be taken to ensure that the system pressure is, in fact, zero. If necessary, remove the line to the system pressure transducer. Pressing **ENTER** will now cause the "AUTO SENTRY-ES" to calibrate the transducer output to zero PSI. Obviously, pressure measurement errors will be encountered if 'zeroing' is done with pressure at the transducer.
23. In the top line, **REMOVE RES PRESS** is displayed. The bottom line displays the current pressure being sensed in the air/oil reservoir. The reservoir pressure transducer may now be 'zeroed' by following the steps outlined in 22 above.
24. The display now reads **PRESS CNST RUNTO JOG MOTOR**. Pressing the "CONSTANT RUN" key will briefly energize the starters, causing the compressor to rotate 1/4 to 1-1/2 revolutions to allow a rotation check.

This completes the programming and setup procedures for the "AUTO SENTRY-ES" controller.

NOTICE

Press the "STOP-RESET" key to return the compressor to the Ready Mode.

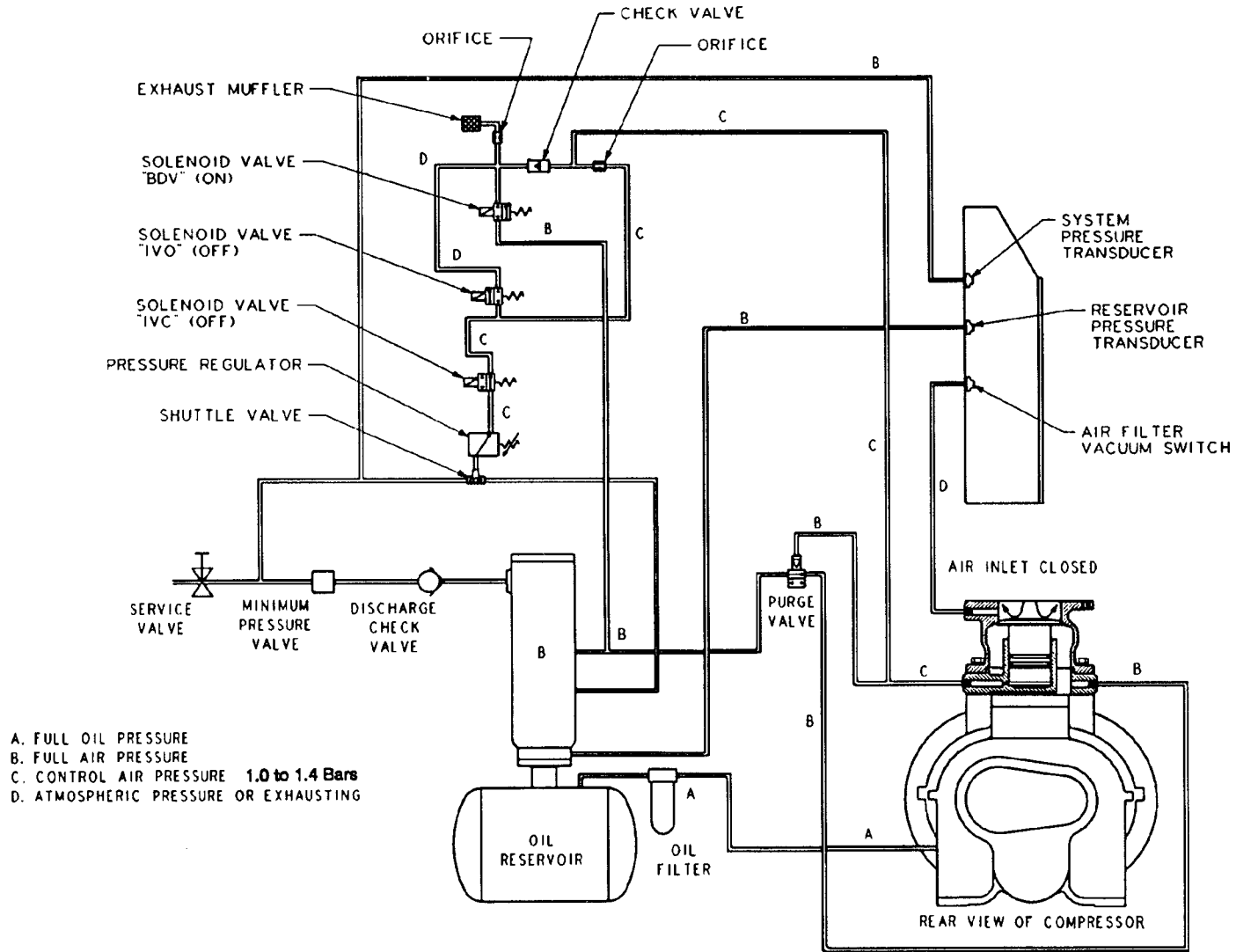

FIGURE 4-6 - CONTROL SCHEMATIC - COMPRESSOR UNLOADED - CONSTANT SPEED MODE

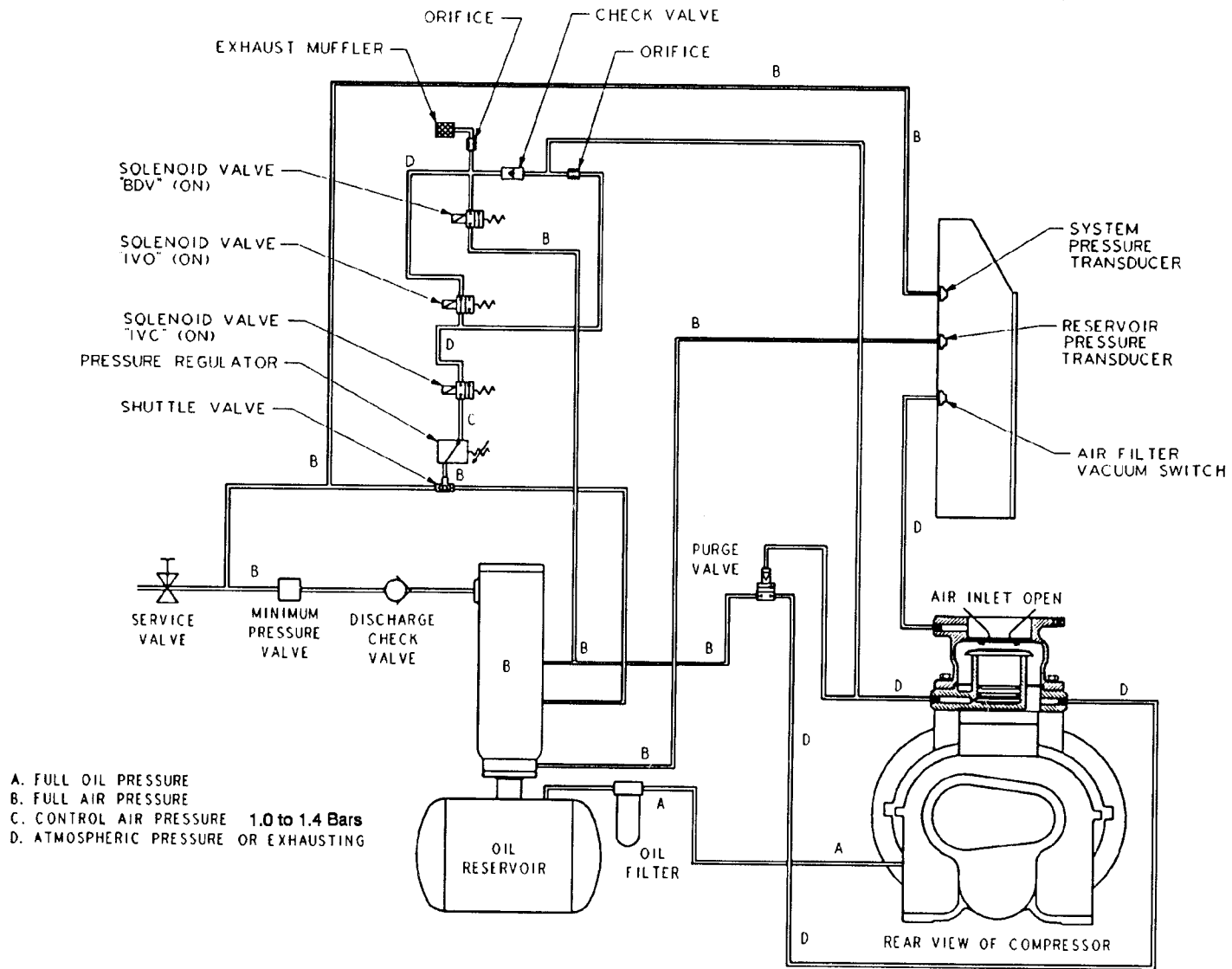

FIGURE 4-7 - CONTROL SCHEMATIC - COMPRESSOR AT FULL LOAD -

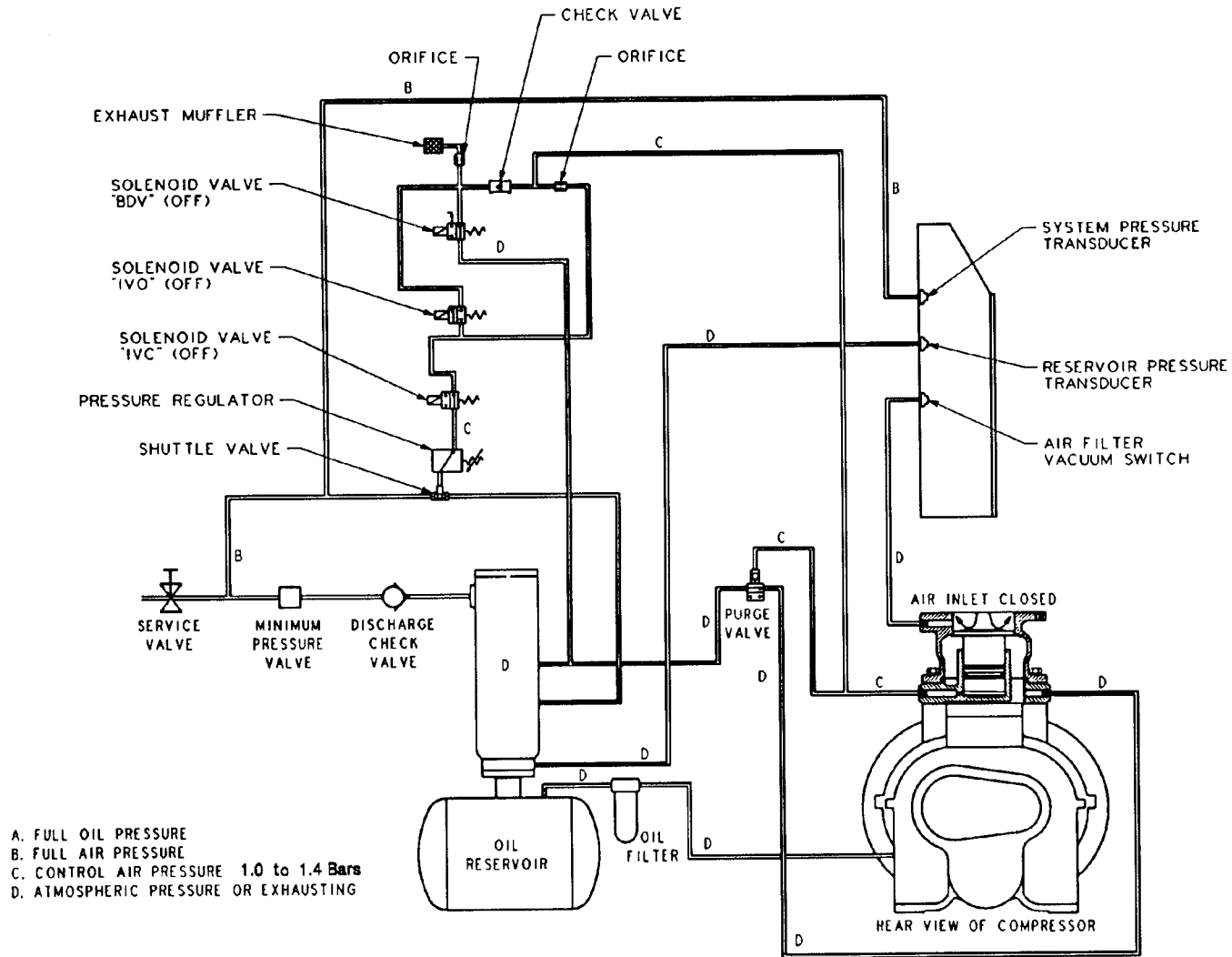

FIGURE 4-8 - CONTROL SCHEMATIC - COMPRESSOR UNLOADED - LOW DEMAND MODE

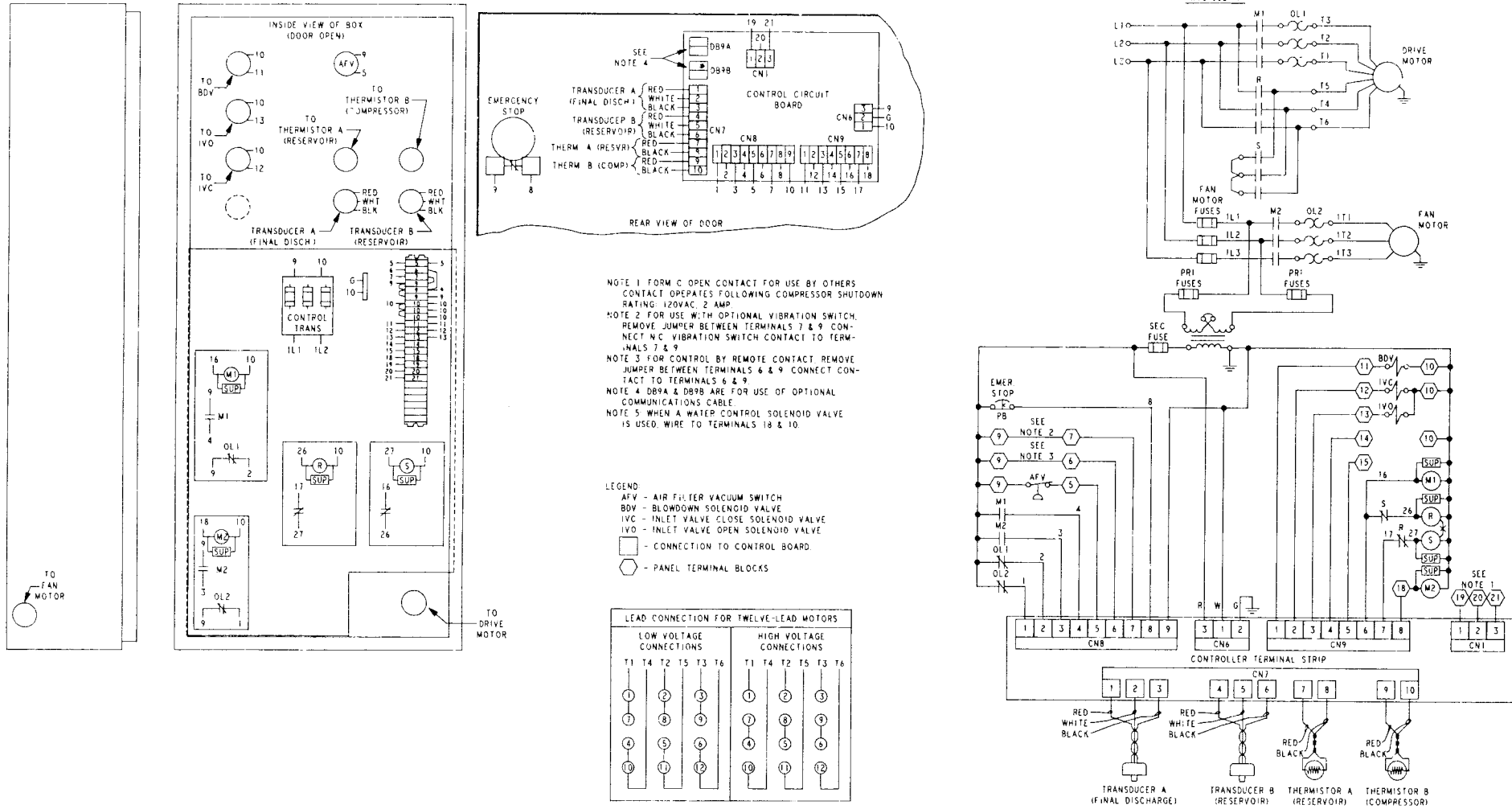

FIGURE 4-9 - WIRING DIAGRAM - 206EDM546

GARDNER-DENVER®

OPERATE

- STOP / RESET
- CONSTANT RUN
- LOW DEMAND
- AUTOMATIC
- SEQUENCE

STATUS

- SHUTDOWN
 - ADVISORY
 - RUN

AUTO
RESTART

PROGRAM

AUTO SENTRY ES®

SECTION 5 LUBRICATION OIL COOLER, OIL FILTER & SEPARATOR

COMPRESSOR OIL SYSTEM (Figure 5-1, Section 5, page 2) cools the compressor, lubricates moving parts and seals internal clearances in the compression chamber.

The oil inlet line is connected at the bottom of the oil reservoir. Air pressure in the oil reservoir forces oil through the oil cooler, thermostatic mixing valve, oil filter and into the compressor main oil gallery.

The oil passes through internal passages for lubrication, cooling and sealing. The air-oil mixture is then discharged to the oil reservoir where a large part of the entrained oil drops out of the air stream; the air then passes through the final oil separator where most of the remaining oil is removed. The separated oil is returned to the compressor and the air passes to the final discharge line.

RECOMMENDED LUBRICANT - Gardner-Denver compressors are factory filled with AEON™ lubricants. These lubricants are formulated to the highest quality standards and are factory authorized, tested and approved for use in rotary screw compressors. AEON™ lubricants are available through your authorized Gardner-Denver compressor distributor.

OIL SPECIFICATIONS - This compressor is factory filled with AEON™ 9000 lubricating coolant. AEON 9000 is a synthetic extended life lubricant which can extend lubricant change intervals 4 to 10 times that of a petroleum based lubricant. A lubricant analysis program for a periodic check of lubricant quality and remaining life can maximize the change interval

CAUTION

Improper equipment maintenance with use of synthetic lubricants will damage equipment. Oil filter and oil separator change intervals must be adhered to for maximum compressor protection and efficiency -- see maintenance schedule, Section 8, page 1.

CHANGING LUBRICANT - When installing anything other than AEON™ 9000 lubricant in new units, the original lubricant should be drained completely and the system flushed with the new lubricant. Complete draining will involve removal of all plugs in the compressor, oil reservoir and oil lines. In some cases, it may be necessary to remove piping to insure complete draining. To insure complete removal of the original lubricant,

good practice indicates draining of the original lubricant, refilling with the new lubricant, operating for 100 hours, then draining and final refilling with the new lubricant.

Suitability of a particular lubricant for use in Gardner-Denver compressors, other than AEON™ lubricants, is to be determined solely by the lubricant supplier and will not specifically be authorized, recommended, or tested by Gardner-Denver Industrial Machinery. Any suitabilities or warranties implied by the use of such lubricants are the responsibility of the manufacturer or supplier. Except in the case of AEON™ brand lubricants, Gardner-Denver Industrial Machinery will not comment on the suitability of any compressor fluid for use in Gardner-Denver rotary screw compressors.

CAUTION

Use of improper lubricants will cause damage to equipment. Do not mix different types of lubricants or use inferior lubricants.

HIGH TEMPERATURE OPERATION - Short periods of up to four (4) hours of sustained discharge temperatures up to 98.9°C (210°F) do not require a change from the recommended year-round lubricant. If the discharge temperature is sustained between 93.3-98.9°C (200-210°F) for a period of more than four (4) hours due to continuing high ambient air temperature, use only Gardner-Denver® AEON 9000 Lubricating Coolant which is a superior synthetic lubricant.

LUBRICANT CHANGE PROCEDURE - Following are the primary steps to be completed when upgrading or changing the type of lubricant.

1. Thoroughly drain system:
 - Drain the oil from the air end and cooler while hot.
 - Break low point connections and drain oil from pipe runs.
 - Dump the oil from the filter and reinstall used filter.
2. Fill system with a 50 percent charge of the new lubricant:
 - Start machine and stay there to observe.
 - Allow machine to run about five minutes at temperature, or until temperature stabilizes, then shut down.
3. Thoroughly drain machine.

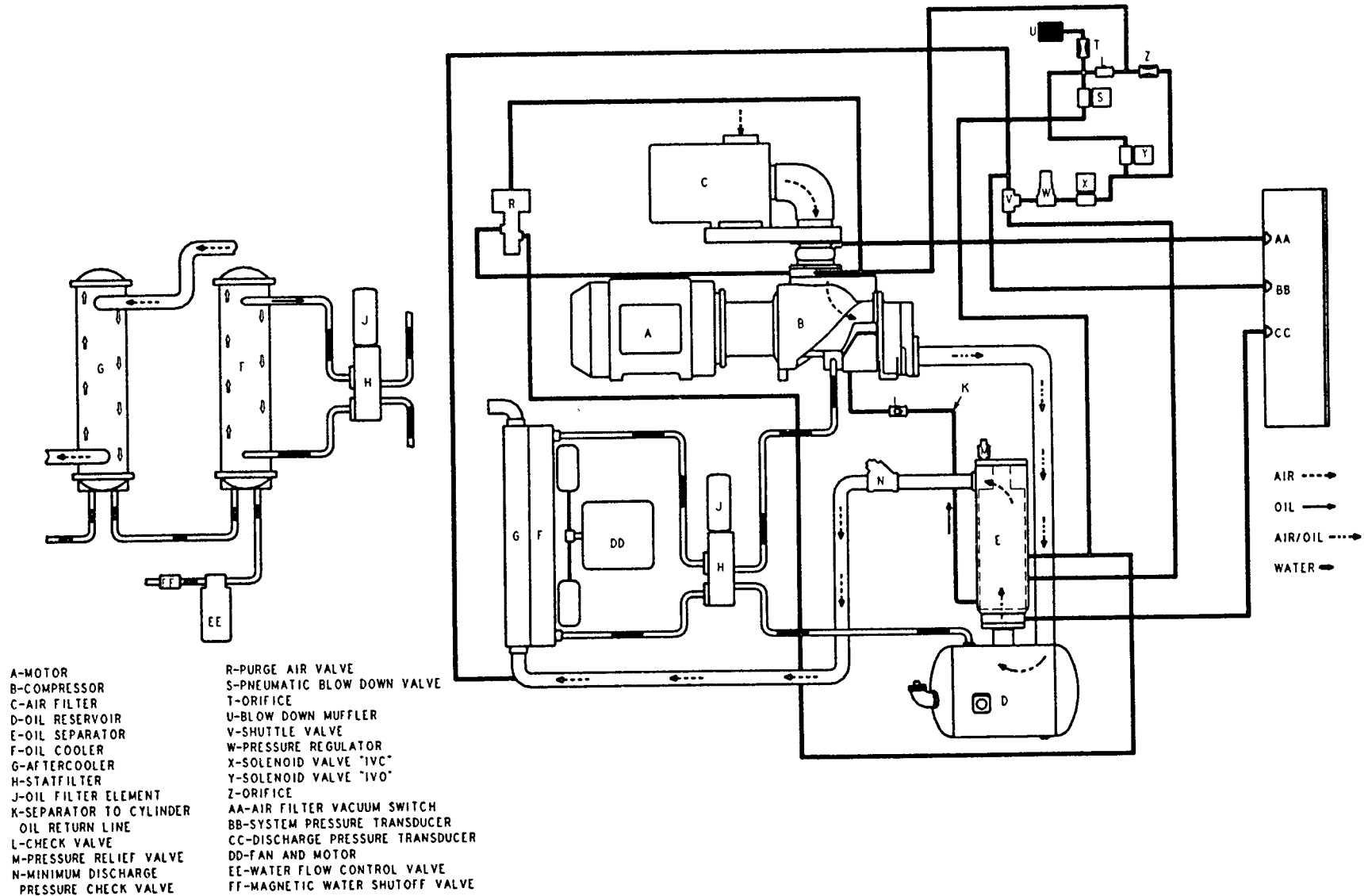

FIGURE 5-1 - FLOW DIAGRAM - AIR-OIL SYSTEM

4. Change to new filter and separator.
5. Fill the system with a full charge of new lubricant.
6. Machine should then be run normally, however, total run time after the initial changeout should be 50 percent of normal anticipated service life of the new lubricant.
 - Drain all lubricant from system, change filter and separator, and replace with full charge of the new lubricant.
7. Subsequent lubricant changeouts should be at normal intervals (see Chart, Section 5, page 6).

⚠ CAUTION

Improper equipment maintenance with use of synthetic lubricants will damage equipment. Oil filter and oil separator change intervals remain the same as for AEON™ 9000 -- See maintenance schedule, Section 8, page 1.

⚠ DANGER

Oil under pressure will cause severe personal injury or death. Shut down compressor and relieve system of all pressure, disconnect, tag and lockout power supply to starter before removing valves, caps, plugs, fittings, bolts and filters.

⚠ WARNING

High temperature operation can cause damage to equipment or personal injury. Do not repeatedly restart after high temperature stops operation. Find and correct the malfunction before resuming operation.

⚠ WARNING

All materials used in Gardner-Denver compressor units are compatible with AEON™ 9000 Lubricating Coolant. Use caution when selecting downstream components such as air line lubricating bowls, gaskets and valve trim.

AEON™ 9000 Synthetic Lubricant is not compatible with low nitrile Buna N or acrylic paints. AEON™ 9000 is compatible with most air system downstream components.

Material Safety Data Sheets (MSDS) are available for all AEON lubricants from your authorized Gardner-Denver distributor or by calling 217-222-5400.

REMOTE MOUNTED ELEVATED COOLER ASSEMBLY PROCEDURE - The compressor package will be built and tested with the coolers mounted on the package. On enclosed units, the fan motor will be disconnected after test and the vent fan motor connected in its place. The vent fan will be mounted in the enclosure. A contactor (starter) will be shipped loose and remote mounted with the cooler by others upon start-up at the job site. The control box will be wired for remote elevated coolers at the factory.

NOTICE

All requirements of local codes should be followed.

When connecting pipe fittings to the cooler, support the threaded coupling with a pipe wrench when tightening the connection. Use silicone sealant on all steel to aluminum threaded connections. All piping should be firmly supported to avoid strain on the cooler manifold and connections. Flexible connections should be installed in all interconnecting piping, adjacent to the cooler, to avoid transmitting piping weight or vibrations to the cooler elements. Before beginning installation, check to be sure that no debris or foreign matter remains in the couplings or cooler bodies. Be certain interconnecting

	<u>93 & 112 KW (125 & 150 HP)</u>
Refill Capacity For Normal Oil Change	79.5 Liters (21.0 U.S. Gallons)
Red To Yellow Range.....	13.25 Liters (3.5 U.S. Gallons)

FIGURE 5-2 - APPROXIMATE OIL SYSTEM CAPACITIES

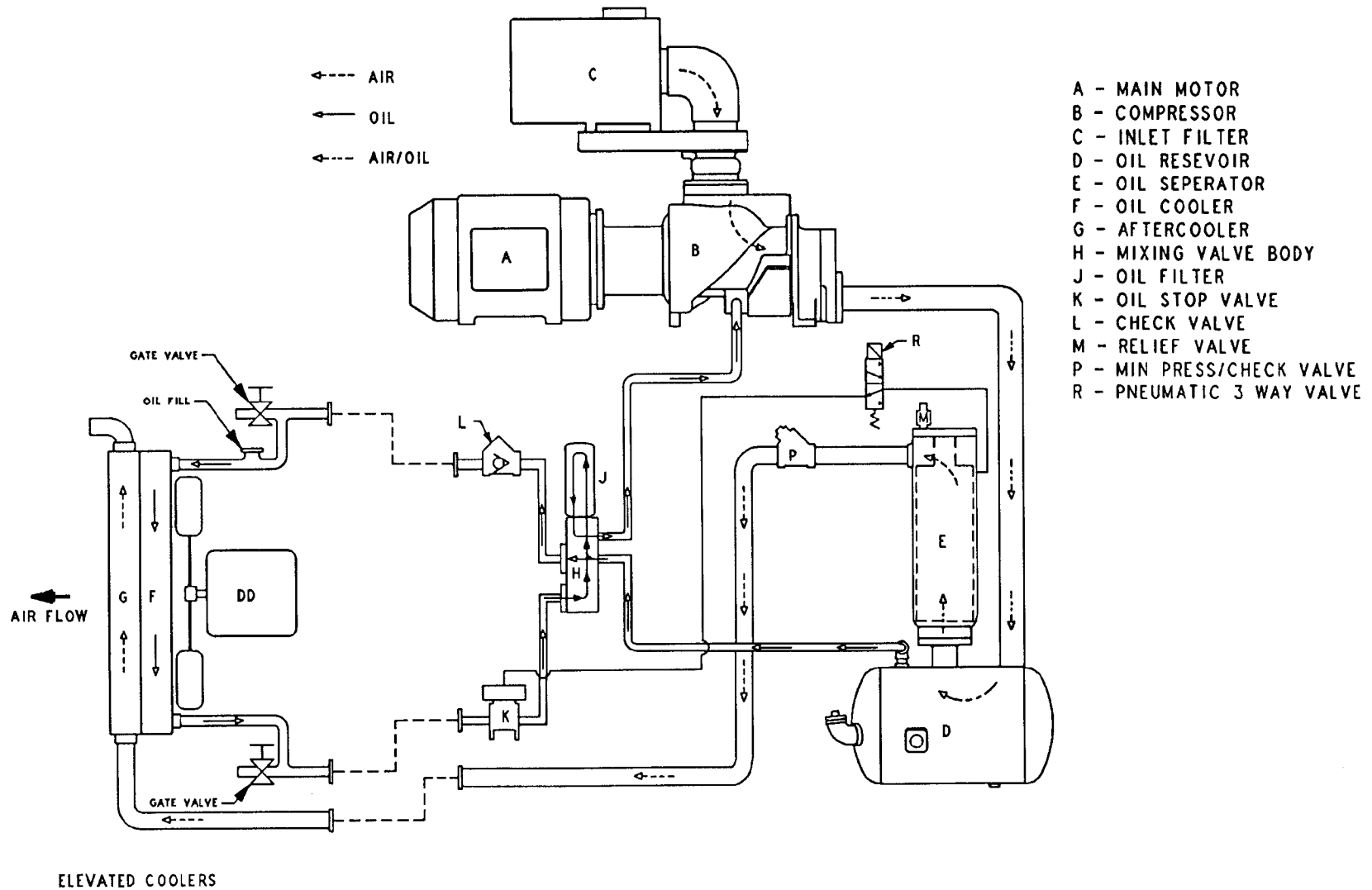

FIGURE 5-3 - OIL FLOW DIAGRAM - REMOTE OVERHEAD MOUNTED COOLER

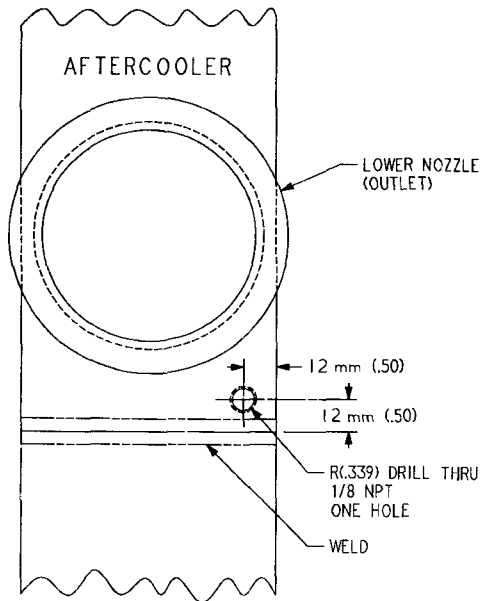

FIGURE 5-4 - COOLER DRAIN DETAIL

pipng is clean to avoid clogging the cooler passages.

AFTERCOOLER PIPING - At shutdown of the system, all units should be drained completely of condensate if there is any possibility of freezing or corrosion damage. To help remove the condensate, the cooler may be tapped per Figure 5-4 and a drain cock installed. After opening the drain cock blow air into the cooler from a connection on the opposite side of the cooler. At the same time the connection on the drain side of the cooler should be plugged. The drain cock should be left open until the machines are ready for start-up.

WARNING

Failure to remove condensate from an idle cooler in freezing temperatures will cause permanent cooler damage. Drain condensate after system shutdown. It is the owner/operator's responsibility to ensure that condensate has been drained and cooler dried out to prevent cooler damage.

HEAT EXCHANGER (OIL) PIPING - All remote elevated cooler applications must be sent through Engineering for approval and for recommending the pipe size. Kit number 210EAQ4013 has the flanges for the cooler and filterstat connections (for the O-ring seal) and the filterstat support. It is recommended that these flanges be used to eliminate oil leakage. When the cooling module is removed from the package, the filterstat assembly (H) remains on the package. The filterstat will need the shipped loose support assembled to it. Control

group part number 200ECM4002 will be mounted on the package at the factory. This group controls the oil stop valve as well as not allowing the machine to run unloaded. See Figure 5-3, page 4, this section.

NOTICE

Remote mounted elevated coolers have a maximum pipe length of 30 feet (each way) and a maximum height of 20 feet with a minimum of fittings. Engineering will review all remote elevated cooler applications and recommend pipe size on an individual basis. customer service should include the engineering recommendation in the special order sent to Engineering.

Kit number EAQ68330 includes the oil stop valve, check valve and flanges and must be installed on all remote elevated coolers per Figure 5-3, page 4, this section, and the following instructions. Mount the check valve (90J113) as shown. Mount the drain valves in the lowest section of the pipe on each side of the cooler connections. Mount the oil stop valve (90AR243) in the line after the thermal mixing valve as shown. Modifications to the control lines will be made at the factory per 288ECM810 schematic. Air to the oil stop valve must come from the upper fitting in the separator housing, then pass through the 3-way pneumatic valve. Control air to the valve must be from the line between the tee and the orifice in the blowdown muffler line per Figure 5-3, page 4, this section. When the machine blows down, it will activate the pneumatic valve and it will shut off the air and vent the line between the pneumatic control valve and the oil stop valve to atmosphere. This will shut the oil stop valve and prevent excessive oil from running into the reservoir. Failure to install these parts could result in high oil carryover and causing the machine to shutdown on high discharge temperature.

COLD AMBIENT OPERATION - See "Installation for Cold Weather Operation," Section 2, page 2.

ADDITION OF OIL BETWEEN CHANGES -

DANGER

Air/oil under pressure will cause severe personal injury or death. Shut down compressor and relieve system of all pressure, disconnect, tag and lockout power supply to starter before removing valves, caps, plugs, fittings, bolts, and filters.

CAUTION

Excessive oil carryover can damage equipment. Never fill oil reservoir above "FULL" marker.

Addition of oil between changes must be made when the oil level is at the bottom of the red range on the gauge as read while the unit is running. To add oil, follow these steps:

1. Be sure the unit is completely off and that no air pressure is in the oil reservoir.
2. Disconnect, tag and lockout the power supply to the starter.
3. Wipe away all dirt around the oil filler plug.
4. Remove the oil filler plug and add oil as required to return the oil level to the green range.
5. Install the oil filler plug, run and check for leaks.

DO NOT OVERFILL. The quantity required to raise the oil level from the red range to the center of the green range is shown in Figure 5-2, page 3, this section. Repeated addition of oil between oil changes may indicate excessive oil carry-over and should be investigated.

DANGER

Air/oil under pressure will cause severe personal injury or death. Shut down compressor and relieve system of all pressure, disconnect, tag and lockout power supply to starter before removing valves, caps, plugs, fittings, bolts, and filters.

CAUTION

Excessive oil carryover can damage equipment. Never fill oil reservoir above "FULL" marker.

OIL LEVEL GAUGES (Figure 5-5) indicate the amount of oil in the oil reservoir. Read oil level when unit is on. In operation the oil level will fluctuate as the compressor loads and unloads. Add oil only when the oil is at the bottom of the red range on the gauge as read when the compressor is on. Drain oil only when the oil level is in the yellow range on the gauge as read when the compressor is on.

MOISTURE IN THE OIL SYSTEM - In normal humidity and with normal operating temperatures and pressures, the thermal mixing valve controls the oil temperature and prevents moisture contamination of the oil. Unusual

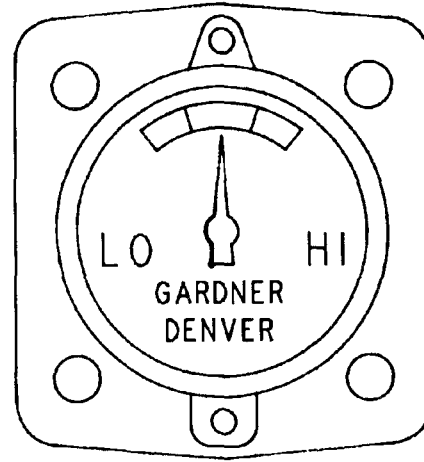

FIGURE 5-5 - OIL LEVEL GAUGE

cooling of the oil reservoir, short loaded cycle in high humidity or malfunctions of the thermal valve may result in moisture in the oil system which is detrimental to compressor lubrication and could cause oil carryover. If moisture is observed in the oil reservoir, drain the moisture and correct the condition causing the accumulation. See "Compressor Oil System Check" and "Thermal Control (Thermostatic Mixing) Valve" in this section.

OIL CHANGE INTERVAL - Recommended oil change intervals are based on oil temperature.

AEON™ 9000

Discharge Temperature	Oil Change Interval
Up to 82°C (180°F)	8000 hrs.
82-88°C (180 to 190°F)	6000 hrs.
88-93°C (190 to 200°F)	4000 hrs.
93°C (200°F) and above	2000 hrs.

When operating conditions are severe (very dusty, high humidity) it will be necessary to change the oil more frequently. Operating conditions and the appearance of the drained oil must be surveyed and the oil change intervals planned accordingly by the user. A lubricant analysis program can provide maximum service life and assist in planning the change interval.

DRAINING AND CLEANING OIL SYSTEM -

DANGER

Air/oil under pressure will cause severe personal injury or death. Shut down compressor and relieve system of all pressure, disconnect, tag and lockout power supply to starter before removing valves, caps, plugs, fittings, bolts, and filters.

Always drain the complete system. Draining when the oil is hot will help to prevent varnish deposits and carry away impurities. To drain the system, use one of the following methods:

If the unit is not elevated high enough to use the oil reservoir drain line to drain oil, a small hand, electric or air operated pump should be used to drain the reservoir through the oil filler opening or from the drain valve.

If the unit is elevated so that the oil reservoir drain can be used, empty the oil reservoir through the drain valve to a suitable container or sump.

If the drained oil and/or the oil filter element are contaminated with dirt, flush the entire system: reservoir, oil cooler, mixing valve and lines. Inspect the oil separator elements for dirt accumulation; replace if necessary. If a varnish deposit exists, contact the factory for recommendations for removal of the deposit and prevention of varnish.

FILLING OIL RESERVOIR -

DANGER

Air/oil under pressure will cause severe personal injury or death. Shut down compressor and relieve system of all pressure, disconnect, tag and lockout power supply to starter before removing valves, caps, plugs, fittings, bolts, and filters.

1. Be sure the unit is completely off and that no air pressure is in the oil reservoir.
2. Disconnect, tag and lockout the power supply to the starter.
3. Wipe away all dirt around the oil filler plug.
4. Remove the oil filler plug and add oil as required to return the oil level to the center of the green range on the gauge.
5. Install the oil filler plug, run and check for leaks.
6. Operate unit for about a minute allowing oil to fill all areas of the system.
7. Shut down unit, allowing the oil to settle, and be certain all pressure is relieved.
8. Add oil, if necessary, to bring the level to the center of the green range on the gauge.

On unloaded operation and after shutdown some oil will drain back into the oil reservoir and the oil level will read over "FULL". DO NOT DRAIN OIL TO CORRECT. On the next start, oil will again fill the system and the gauge will indicate operating at the proper level. DO NOT OVERFILL as oil carryover will result. The quantity of oil required to raise the oil level from "ADD" to "FULL" is

shown in Figure 5-2, page 3, in this section. Repeated addition of oil between oil changes may indicate excessive oil carryover and should be investigated.

Use only CLEAN containers and funnels so no dirt enters the reservoir. Provide for clean storage of oils. Changing the oil will be of little benefit if done in a slipshod manner.

CAUTION

Excessive oil carryover can damage equipment. Never fill oil reservoir above "FULL" marker.

COMPRESSOR OIL FILTER (Figure 1-5, Section 1, page 3) - This patented design screw on oil filter is a vital part in maintaining a trouble-free compressor, since it removes dirt and abrasives from the circulated oil. The oil filter relief valve is located in the manifold under the 1-1/4 inch pipe plug. The relief valve opens in the event the element becomes dirty enough to block flow of oil.

CAUTION

Improper oil filter maintenance will cause damage to equipment. Replace filter element every 1000 hours of operation. More frequent replacement could be required depending on operation conditions. Filter element left in service too long may damage equipment.

Use only complete oil filter for replacement. The part number is on the filter head and in the parts list.

NOTICE

The head and the filter body are bonded together and cannot be purchased separately.

Use the following procedure to replace the filter. Do not disturb the piping.

DANGER

Air/oil under pressure will cause severe personal injury or death. Shut down compressor and relieve system of all pressure, disconnect, tag and lockout power supply to starter before removing valves, caps, plugs, fittings, bolts, and filters.

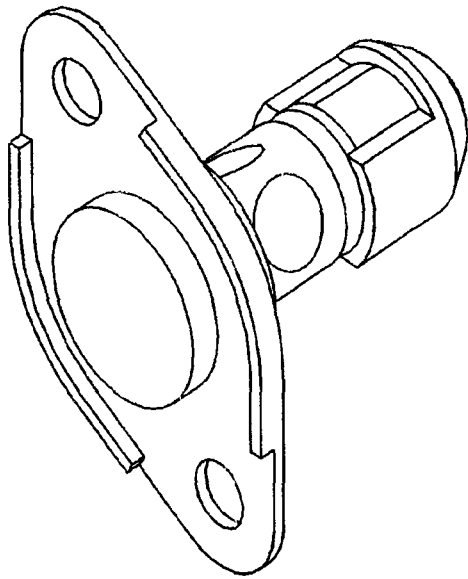

FIGURE 5-6 - THERMOSTATIC MIXING VALVE

1. Stop unit and be sure no air pressure is in the oil reservoir.
2. Unscrew oil filter from housing and remove.
3. Screw new oil filter into housing.
4. Run the unit and check for leaks.

COMPRESSOR OIL COOLER - RADIATOR TYPE (Figure 1-5, Section 1, page 3) - The cooler motor and fan are mounted on the oil cooler module; air is exhausted through the oil cooler and away from the unit. Do not obstruct air flow to and from the oil cooler. Allow a minimum of 1 M (3 feet) clearance around the cooler. Keep both faces of the cooler core clean for efficient cooling of the compressor oil.

THERMAL CONTROL (THERMOSTATIC MIXING) VALVE (Figure 5-6) is installed in system as shown in Figure 5-1, page 2, this section. This valve is used to control temperature of the oil both air-cooled radiator and water-cooled heat exchanger type oil cooler systems. On start-up with unit cold, element is open to bypass, allowing oil to pass directly from the reservoir to compressor during warm-up. As oil warms, the element gradually closes to the bypass allowing more of the oil from the cooler to mix with oil from the bypass.

After the unit is warmed up, the mixing valve maintains oil injection temperature into the compressor at a minimum of 66°C (150°F). This system provides proper compressor warm-up and prevents moisture contamination of the oil.

If the unit shuts down due to high air discharge temperature, it may be that one or both thermostatic mixing

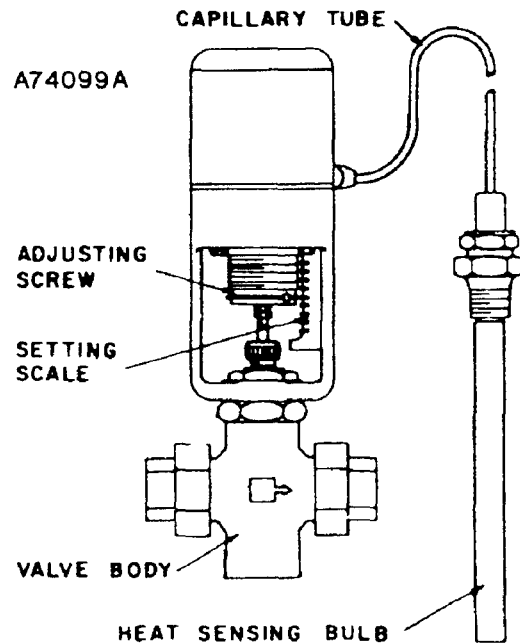

FIGURE 5-7 - WATER CONTROL VALVE

valve elements (Figure 5-1, page 2, this section) are stuck open to the bypass, in which case the bypass lines will be hot to touch and lines out of the mixing valve much cooler. To check element, heat element in oil. It should be fully extended at 66° C (150°F). Remove mixing valve and clean all parts thoroughly when flushing the oil system.

COMPRESSOR OIL COOLER - WATER-COOLED HEAT EXCHANGER (Figure 5-1, page 2, this section) - The heat exchanger oil cooler is a multiple pass type, with water in the tubes and oil in the shell. The oil temperature is controlled by the thermal (thermostatic mixing) valve. The optional water control valve may be used to conserve water.

Oil cooler malfunction may be traced by checking pressure at oil inlet and outlet. At normal operating air service pressure (4.5 to 10.3 Bars, 65 to 150 psig) with the unit warm, a pressure drop of .2 to 1 Bar (3 to 15 psi) can be expected between the oil inlet and the oil outlet.

Water pressure drop from water inlet to outlet will vary with the inlet pressure and amount of water flowing. A normal pressure drop may range from .3 to .7 Bar (5 to 10 psi). Any change in the pressure drop from that normally held may indicate tube leakage or fouling and should be investigated.

In many instances, the cooling water supply for the heat exchanger will contain impurities in solution and/or suspension. These substances can cause scale formation, corrosion and plugging of any water-cooled heat exchanger equipment. Disregarding the possibility that one or more of these conditions exist may result in increased maintenance and operation expense, reduced equipment life and emergency shutdown. It is

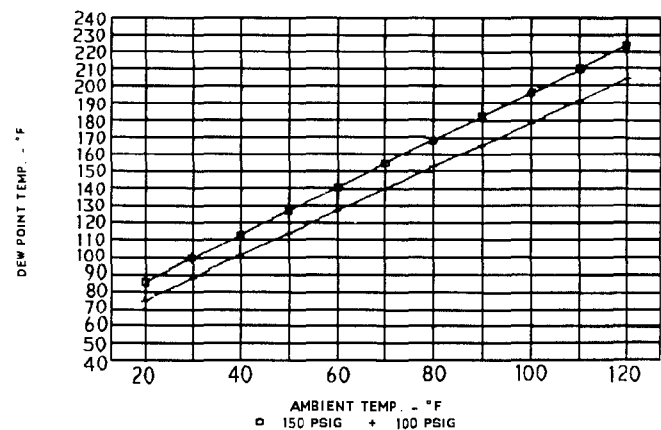
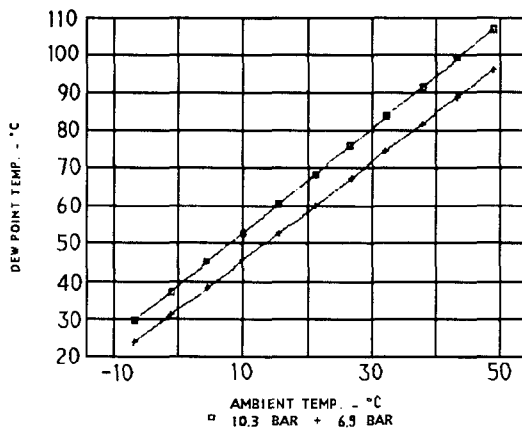

FIGURE 5-8 - DEW POINT TEMPERATURE VS. AMBIENT TEMPERATURE (100% RELATIVE HUMIDITY)

strongly recommended that a reputable, local water treatment concern be engaged to establish the corrosion, scale forming and fouling tendency of the cooling water and take steps necessary to remedy the situation if a problem does exist. The need for water treatment may involve only filtration (screening) to remove debris, sand and/or salt in the cooling water supply. However, chemical treatment methods may be necessary in certain instances to inhibit corrosion and/or remove dissolved solids, to alter the water's tendency to form scale deposits, or prevent the growth of microorganisms. The normal maintenance program for the unit should also include periodic cleaning of the tubes (water side) of the heat exchanger to remove deposits which enhance fouling and corrosion.

Hex head zinc anodes are used in the return bonnet (opposite end to the water pipe connections) of heat exchangers to provide internal water system corrosion protection. These anodes should be inspected periodically and replaced when the zinc has been reduced to about 13 mm (1/2 inch) in length.

WATER FLOW CONTROL VALVE FOR HEAT EXCHANGER (Optional Equipment) (Figure 5-7, page 8, this section) - The water flow control valve is adjustable to compensate for varying water inlet temperatures and pressures and is to be mounted in the water outlet line after the oil cooler (Figure 5-1, page 2, this section). Use the compressor discharge air temperature gauge on the instrument panel in setting the flow control valve. The compressor discharge temperature must be maintained a minimum of 10° F above the dew point temperature at the maximum anticipated ambient; refer to Figure 5-8 for the dew point temperature at the operating pressure and ambient temperature of the application.

To decrease water flow (increase compressor discharge air temperature) turn the adjusting screw from left to right, increasing spring tension. **To increase water flow** (decrease compressor discharge air temperature) turn the adjusting screw in the opposite direction.

The groove at the lower edge of the adjusting screw is an index line for use with the index scale 0 to 8 in obtaining a desired setting.

These valves must be handled with care and proper tools and techniques must be used when working on valve.

Care must be used when handling the capillary tube; a kink or break in the tubing or connections will make the valve inoperative. Never attempt to change capillary length. Excess capillary tube should be carefully coiled and placed so that damage will not occur in normal maintenance or traffic past the unit.

If the leak develops through the packing, tighten the packing gland nut firmly with a wrench to reseal the packing around the valve stem, then back off the nut until loose, and finally retighten the nut finger tight. Tightening the packing nut too tight may cause erratic operation. An occasional drop of oil on the valve stem at the packing nut will prolong packing life.

If valve malfunctions, check for bent or binding (paint or corrosion) valve stem, foreign material in valve, erosion, or thermal system (capillary) failure. If foreign material or scale is likely, the use of a strainer in the inlet water line is recommended.

WATER SHUTOFF VALVE - WATER COOLED HEAT EXCHANGER (Optional Equipment) (Figure 5-1, page 2, Section 5) - A magnetic solenoid-operated water shutoff valve rated at 10.3 Bar (150 psig) water pressure should be mounted in the water outlet line after the oil cooler. The valve should be wired into the compressor control circuit so that the valve opens to allow water to flow any time the compressor is running. When the compressor stops under automatic control, or is shut off manually, the valve should close, stopping water flow through the system. See the wiring diagram, Figure 4-9, Section 4, page 12.

OIL RESERVOIR - The oil reservoir-separator combined multiple functions into one vessel. The lower half

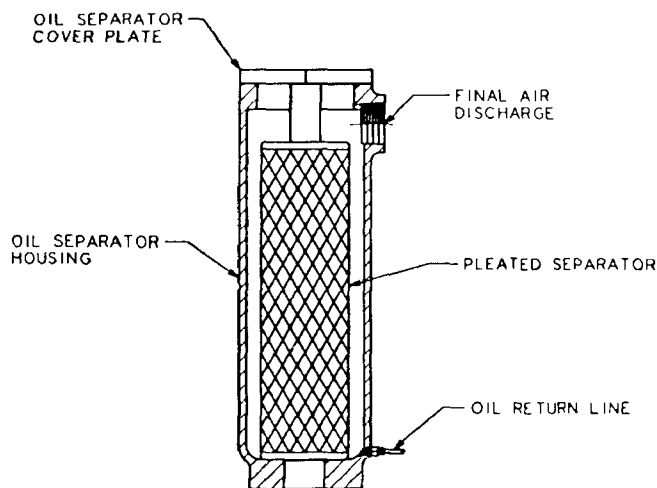

FIGURE 5-9 - OIL SEPARATOR

is the oil reservoir, providing oil storage capacity for the system and the top portion, a primary oil separation means. The reservoir also provides limited air storage for control and gauging actuation.

COMPRESSOR (G-D ELIMINATOR) OIL SEPARATOR located in a separate housing, consists of a renewable cartridge-type separator element and provides the final removal of oil from the air stream.

Oil impinging on the inside of the separator element drains directly back into the oil reservoir by gravity. Oil collected outside the element is returned through tubing to the compressor cylinder.

Oil carry-over through the service lines may be caused by a faulty oil separator, overfilling of the oil reservoir, oil that foams, oil return line malfunction, or water condensate in the oil. If oil carryover occurs, inspect the separator only after it is determined that the oil level is not too high, the oil is not foaming excessively, the oil return tube from the bottom of the separator to the compressor cylinder is not clogged or pinched off, the check valve in the oil return is functioning properly, and there is not water or an oil/water emulsion in the oil.

Oil carry-over malfunctions of the oil separator are usually due to using elements too long, heavy dirt or varnish deposits caused by inadequate air filter service, use of improper oil or using oil too long for existing conditions. Excessive tilt angle of the unit will also hamper separation and cause oil carry-over.

The oil separator element life cannot be predicted; it will vary greatly depending on the conditions of operation, the quality of the oil used and the maintenance of the oil and air filters. The condition of the separator can be determined by pressure differential or by inspection.

Pressure Differential Gauging - The "CHANGE SEPARATOR" advisory will flash when the pressure differential

across the oil separator reaches approximately .6 BAR (8 PSI). Replace the oil separator element at this time. If ignored, the unit will shut down and the advisory will illuminate steadily when the pressure differential reaches 1 BAR (15 PSI).

CAUTION

Using an oil separator element at excessive pressure differential can cause damage to equipment. Replace separator when "Change Separator" message flashes.

NOTICE

A sudden drop to zero pressure differential or sudden heavy oil carryover may indicate a ruptured element.

Inspection - After removal of the separator element, shine a light inside the element to reveal areas of heavy dirt or varnish deposits or breaks (ruptures) in the element media.

Removal Of Oil Separator For Inspection Or Replacement:

DANGER

Air/oil under pressure will cause severe personal injury or death. Shut down compressor and relieve system of all pressure, disconnect, tag and lockout power supply to starter before removing valves, caps, plugs, fittings, bolts, and filters.

1. Be certain unit is completely off and that no air pressure is in the oil reservoir.
2. Disconnect, tag and lockout the power supply to the starter.
3. Remove screws holding the top plate to the separator housing. Lift top plate from the separator housing.
4. Lift the separator from the separator housing.
5. Inspect and/or replace the separator as necessary. Be sure the o-ring is not damaged. Before installing (or re-installing) any separator, apply grease to the o-ring. Oil will be wiped off by the chamfer and the o-ring could be damaged.

6. Remove any gasket material adhering to the top plate or separator housing, and install new gasket.
7. Lower the separator into the housing and center the separator on the chamfer. Press separator down into housing. Do not use excessive force as separator damage can occur.
8. Place spacer on indent in separator. Seat top plate to separator, spacer and separator housing. Install and tighten all cap screws.
9. Run unit and check for leaks.

COMPRESSOR OIL SYSTEM CHECK - The following readings are based on ambient temperature of 27°C (80°F) with the system in good condition. Compressor should be at operating temperature at the time of checks. One-half hour of loaded operation is usually sufficient to reach level-out operating temperatures.

Air and Oil Discharge Temperature - 74° to 91°C (165° to 195° F) - Read at gauge on the instrument panel or check with a thermometer at the discharge housing.

Compressor Oil Inlet Temperature - 66° to 71°C (150°-160°F) - Install a tee at the oil filter outlet and check with a thermometer.

Oil Inlet Pressure - Check at the fitting in the line near the compressor oil inlet. With air receiver pressure at 6.9 BAR (100 PSI), oil inlet pressure should be 3.8 to 4.1 BARS (55 to 60 PSIG).

Oil Cooler Oil Pressure Differential (Air-Cooled Ra-

diator) - Check differential across oil system by measuring oil inlet pressure as described above.

Oil Cooler Oil Pressure Differential (Water-Cooled Heat Exchanger) - .1 to 1.7 BAR, 2 to 25 PSI (4.5 to 10.3 BARS, 65 to 150 PSIG Receiver Pressure) - Check that oil inlet pressure is correct or measure the differential between drains on the oil cooler shell.

Oil Cooler Temperature Differential (Air-Cooled Radiator) - The oil temperature differential depends on the temperature of the air at the oil cooler fan and cleanliness of the core faces. As ambient temperatures and core restrictions increase, the oil cooler outlet temperature will increase. The oil inlet temperature is approximately the same as the air discharge temperature - see the gauge on the instrument panel. The outlet oil temperature may be checked by installing a tee at the oil filter outlet.

Oil Cooler Temperature Differential (Water-Cooled Heat Exchanger) - The oil temperature differential depends on the inlet water temperature and the water flow rate permitted by the water flow control valve setting. The oil inlet temperature is approximately the same as the air discharge temperature - see the gauge on the instrument panel. The oil outlet temperature may be checked by installing a tee at the oil filter outlet.

Oil Cooler Water Pressure Differential (Water-Cooled Heat Exchanger) - The water pressure differential through the heat exchanger will depend on the supply pressure, flow rate, cooler tube cleanliness and outlet pressure. The inlet and outlet water pressure may be checked at the pipe fittings supplied by the customer.

SECTION 6 AIR FILTER

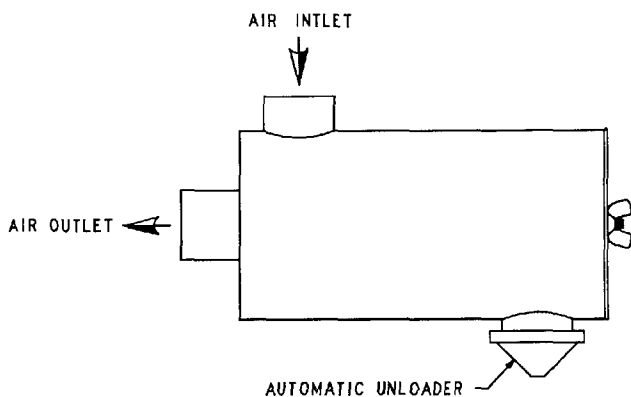

FIGURE 6-1 - HEAVY DUTY AIR FILTER (STANDARD)

HEAVY-DUTY AIR FILTER (Figure 6-1) furnished as standard equipment on units with an enclosure is a heavy-duty washable element dry type air filter. The air filter must receive proper maintenance if maximum service is to be obtained from the unit. Establishing adequate and timely filter service is **MOST IMPORTANT**. Improperly maintained air filter can cause a loss of compressor air delivery.

Filter Element - Service the air filter element when the "CHANGE AIR FILTER" LED is illuminated. Clean every 50 to 150 operating hours depending on dust conditions.

NOTICE

Use only genuine Gardner-Denver air filter elements on Gardner-Denver compressor units. Genuine parts are available through your authorized Gardner-Denver distributor.

To service:

1. Remove wingnut and pull out filter element.
2. Visually inspect the element. If cleaning is not necessary, reinstall the filter element. If the element requires cleaning, go through steps 3, 4 and 5.
3. Wash the element by soaking about 15 minutes in warm water with a mild nonsudsing detergent. Rinse the element thoroughly with clean water; a hose may be used if the water pressure does not exceed 2.8 BARS (40 PSIG).
4. Inspect the element for ruptures or cracks in the pleated media; replace the element if any are

found. Inspect the gasket on the bottom (outlet end) of the element; replace the entire element if the gasket is damaged, a spare element will keep down time to a minimum.

5. Allow the element to air dry **COMPLETELY**. Do not expose the element to heat over 66°C (150° F). Install the element in the filter body and fasten securely with the wing nut.

WARNING

Do not oil this element. Do not wash in inflammable cleaning fluids. Do not use solvents other than water. Improper cleaning may damage element.

CAUTION

Never operate the unit without the element. Never use elements that are damaged, ruptured or wet. Never use gaskets that won't seal. Keep spare elements and gaskets on hand to reduce downtime. Store elements in a protected area free from damage, dirt and moisture. Handle all parts with care.

Filter Element Life - The element should be replaced after six (6) cleanings or if:

1. Visual inspection indicates a rupture, crack or pin hole in the pleated media. Inspection should be done by placing a bright light inside the element.
2. Pressure drop through a filter with a freshly cleaned element is below 76 mm (3 inches) of water with compressor running at full load - this would indicate a rupture or crack.

Inlet Tube - Inspect the inlet screen and tube for dirt accumulation each time the filter is serviced. Clean the tube when required by ramming a clean dry cloth through the tube. Wipe the inside of the filter body to remove any dirt falling from the inlet tube before reinstalling the element.

Causes of short element life include: severe dust conditions, infrequent servicing, improper cleaning, or contamination by oil or chemical fumes.

SECTION 7 COUPLING

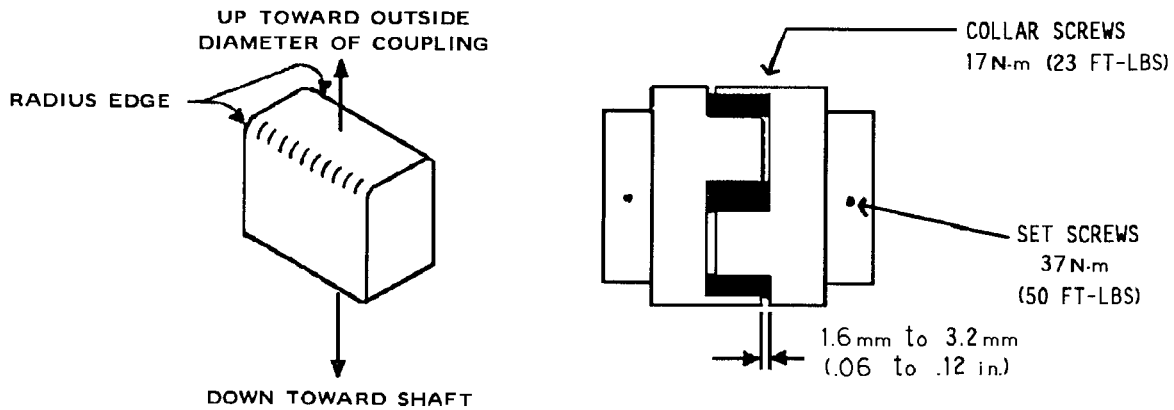

FIGURE 7-1 - INSTALLATION OF COUPLING CUSHIONS

⚠ DANGER

Rotating machinery can cause personal injury or death. Turn unit completely off and open main disconnect before servicing coupling.

COUPLING - The motor and compressor are direct connected by a resilient type flexible coupling with several individual cushions, Figure 7-1. Coupling does not require lubrication.

If maintenance on mating parts is required, reassemble coupling as follows:

Individual Cushion Design (Figure 7-1)

1. Slide coupling halves over shaft extensions. Be sure collar is installed on shaft behind one coupling body.
2. Assemble motor on compressor.

3. Working through coupling guard opening, center coupling over gap between shafts, maintaining gap as shown in Figure 7-1 between the ends of the jaws on one coupling body and the flange on the opposite coupling body. Tighten set screws in each coupling body.
4. Insert individual cushions as shown in Figure 7-1 and slide collar over cushions and secure with cap screws. Reinstall the coupling guard.

⚠ DANGER

Rotating machinery can cause personal injury or death. Do not operate unit with either the coupling guard or the collar removed. All bolts and screws must be properly tightened.

Alignment - The coupling is permanently aligned by the flanges on the compressor and motor.

SECTION 8 MAINTENANCE SCHEDULE

SERVICE CHECK LIST -

Air Filter - Operating conditions determine frequency of service. The "CHANGE AIR FILTER" LED will illuminate to signal that the air filter requires servicing or changing. See "Air Filter," Section 6.

Oil Separator - Operating conditions determine frequency of service. The "CHANGE SEPARATOR" LED will flash to signal that oil separator element requires changing. See "Compressor Oil Separator" in Section 5.

Refer to "Compressor Oil Separator" in Section 5 for further details.

Motor Lubrication - Refer to Section 2 and Maintenance Schedule Chart below.

Every 8 Hours Operation

1. Check the reservoir oil level - add oil if required. See Section 5. If oil consumption is high, refer to "Excessive Oil Consumption" in Section 9, page 3. DO NOT MIX LUBRICANTS.
2. Observe if the unit loads and unloads properly.
3. Check discharge pressure and temperature.
4. Drain the moisture trap in the control system.
5. Check panel LED's for advisories

Every 125 Hours Operation

1. Check for dirt accumulation on oil/aftercooler core faces and the cooling fan. If cleaning is required, clean the exterior fin surfaces of the cores by blowing compressed air carrying a nonflammable safety solvent in a direction opposite that of the cooling fan air flow. This cleaning operation will keep the exterior cooling surfaces clean and ensure effective heat dissipation.

Every 1000 Hours Operation

1. Change oil filter element.

Every 8000 Hours Operation

1. Change the compressor lubricant. UNDER ADVERSE CONDITIONS, CHANGE MORE FREQUENTLY (refer to "Oil Change Interval" in Section 5). Flush system if required. DO NOT MIX LUBRICANTS.

Every 4000 Hours Operation

1. Inspect oil separator element. See Section 5.

Every Year

1. Check the relief valve for proper operation. See Section 4.

MAINTENANCE SCHEDULE (See detail notes above)

Maintenance Action	As Indicated By Auto Sentry-ES	Every 8 Hours	Every 125 Hours	Every 1000 Hours	Every 4000 Hours	Every 8000 Hours*	Every Year
Change Air Filter	•						
Change Oil Separator	•						
Check Reservoir Oil Level		•					
Check For Proper Load/Unload		•					
Check Discharge Pressure/Temp.		•					
Check Dirt Accumulation on Cooler			•				
Change Oil Filter Element				•			
Inspect Oil Separator Element					•		
Change Compressor Lubricant (AEON 9000)	•					•	
Check Relief Valve							•

* See Continuous Operating Temperature Chart for specific lubricant life.

SECTION 9 TROUBLE SHOOTING

Symptom	Possible Cause	Remedy
Compressor fails to start.	<ol style="list-style-type: none">1. Wrong lead connections.2. Blown fuses in control box.3. Motor starter overload heaters tripped.4. Pressure in reservoir.5. Read error message on control panel. See Section 4.6. Remote contact is open (terminals 6 & 9).	<ol style="list-style-type: none">1. Change leads.2. Replace fuse.3. Reset and investigate cause of overload.4. Inspect blowdown valve and muffler.5. Replace switch.6. Replace switch or jumper.
Compressor starts but stops after a short time.	<ol style="list-style-type: none">1. High discharge temperature.2. High discharge temperature switch malfunction.3. Blown fuse in starter/control box.4. Motor starter overload heaters trip.	<ol style="list-style-type: none">1. See "High Discharge Air Temperature" in this section.2. Replace switch.3. Replace fuse (investigate if fuses continue to blow).4. Reset and investigate cause of overload.
Compressor does not unload (or load).	<ol style="list-style-type: none">1. Improperly adjusted control.2. Air leak in control lines.3. Restricted control line.4. Blowdown valve malfunction.	<ol style="list-style-type: none">1. Refer to Section 4 and adjust control.2. Determine source of leak and correct.3. Clean control lines.4. Repair, clean or replace valve.

Symptom	Possible Cause	
Compressor cycles from load to unload excessively.	<ol style="list-style-type: none"> 1. Insufficient receiver capacity. 2. Restriction in control tubing. 	<ol style="list-style-type: none"> 1. Increase receiver size. 2. Inspect and clean control tubing.
Compressor is low on delivery and pressure.	<ol style="list-style-type: none"> 1. Restricted air filter. 2. Sticking inlet valve. 3. Unload pressure adjusted too low. 4. Minimum pressure valve stuck closed. 	<ol style="list-style-type: none"> 1. Clean or replace filter. 2. Inspect and clean inlet valve. 3. Adjust unload pressure. pressure. See Section 4. 4. Disassemble and clean valve.
High discharge air temperature.	<ol style="list-style-type: none"> 1. Thermostatic mixing valve stuck open. 2. Dirty or clogged cooler face. 3. Insufficient cooling air flow. 4. Clogged oil filter or cooler (interior). 5. Low Compressor oil. 	<ol style="list-style-type: none"> 1. Repair or replace valve. 2. Clean cooler. 3. Provide unrestricted supply of cooling air. 4. Replace filter or clean cooler. 5. Add oil to proper level.
Excessive Oil Consumption	<ol style="list-style-type: none"> 1. Oil carryover through lines. 2. Oil leaks at all fittings and gaskets. 	<ol style="list-style-type: none"> 1. See "Oil Carryover in this section. 2. Tighten or replace fittings or gasket.

Symptom	Possible Cause	Remedy
Oil Carry-Over	1. Overfilling the reservoir.	1. Drain excess oil from system.

⚠ DANGER

Air/oil under pressure will cause severe personal injury or death. Shut down compressor and relieve system of all pressure, disconnect, tag and lockout power supply to starter before removing valves, caps, plugs, fittings, bolts, and filters.

- | | |
|--|--|
| 2. Clogged, broken or loose oil return lines | 2. Tighten or replace faulty lines. |
| 3. Ruptured oil separator element. | 3. Replace element. |
| 4. Loose assembly. | 4. Tighten all fittings and gaskets. |
| 5. Foam caused by use of incorrect oil. | 5. Use Gardner-Denver® AEON 9000 Lubricating Coolant. |
| 6. Inoperative minimum pressure valve, causing low operating pressure. | 6. Clean out or replace. |
| 7. Operation at elevated discharge temperatures. | 7. Reduce temperature. See High Discharge Air Temperature - in this section. |
| 8. Scavenge line check valve failure. | 8. Replace check valve |
| 9. Water condensate in oil. | 9. Check oil reservoir temperature. If low, change thermal mixing valve element to higher temperature. |

**AUTO SENTRY ES CONTROLLER
TROUBLE SHOOTING GUIDE
ADVISORIES**

READING	ACTION
'CHANGE SEPARATOR" Light (Flashing or on steadily) On Startup	Separator differential is greater than 8 psid Change separator.
CHANGE AIR FILTER	Inspect/Replace -- air filter if needed.
LOW AMBIENT	The Advisory comes on -- if the receiver or air end discharge is less than 4.4° C (40° F). Refer to corrective measures for low ambient conditions in the Operator's Manual.
HIGH TEMPERATURE	The Advisory comes on -- when the temperature exceeds 99° C (210° F). Probable cause -- plugged or dirty cooler, high ambient conditions, or blown fuses on fan motor.



Gardner-Denver Industrial Machinery

WARRANTY ROTARY SCREW COMPRESSORS OIL INJECTED • OIL FREE

GENERAL PROVISIONS AND LIMITATIONS

Gardner-Denver Industrial Machinery Division (the "Company") warrants to each original retail purchaser ("Purchaser") of its new products from the Company or its authorized distributor that such products are, at the time of delivery to the Purchaser, made with good material and workmanship. No warranty is made with respect to:

1. Any product which has been repaired or altered in such a way, in the Company's judgment, as to affect the product adversely.
2. Any product which has, in the Company's judgment, been subject to negligence, accident, improper storage, or improper installation or application.
3. Any product which has not been operated or maintained in accordance with the recommendations of the Company.
4. Components or accessories manufactured, warranted and serviced by others.
5. Any reconditioned or prior owned product.

Claims for items described in (4) above should be submitted directly to the manufacturer.

WARRANTY PERIOD

The Company's obligation under this warranty is limited to repairing or, at its option, replacing, during normal business hours at an authorized service facility of the Company, any part which in its judgment proved not to be as warranted within the applicable Warranty Period as follows.

COMPRESSOR AIR ENDS

Compressor air ends, consisting of all parts within and including the compressor cylinder and gear housing, are warranted for 24 months from date of initial use or 27 months from date of shipment to the first purchaser, whichever occurs first.

Any disassembly or partial disassembly of the air end, or failure to return the "unopened" air end per Company instructions, will be cause for denial of warranty.

OTHER COMPONENTS

All other components are warranted for 12 months from date of initial use or 15 months from date of shipment to first purchaser, whichever occurs first.

LABOR TRANSPORTATION AND INSPECTION

The Company will provide labor, by Company representative or authorized service personnel, for repair or replacement of any product or part thereof which in the Company's judgment is proved not to be as warranted. Labor shall be limited to the amount specified in the Company's labor rate schedule.

Labor costs in excess of the Company rate schedule amounts or labor provided by authorized service personnel is not provided for by this warranty.

All costs of transportation of product, labor or parts claimed not to be as warranted and, of repaired or replacement parts to or from such service facility shall be borne by the Purchaser. The Company may require the return of any part claimed not to be as warranted to one of its facilities as designated by Company, transportation prepaid by Purchaser, to establish a claim under this warranty.

Replacement parts provided under the terms of this warranty are warranted for the remainder of the Warranty Period of the product upon which installed to the same extent as if such parts were original components.

WARRANTY REGISTRATION VALIDATION

A warranty registration form is provided with each machine. The form must be completed by the Purchaser and mailed within ten days after machine start-up to validate the warranty.

DISCLAIMER

THE FOREGOING WARRANTY IS EXCLUSIVE AND IT IS EXPRESSLY AGREED THAT, EXCEPT AS TO TITLE, THE COMPANY MAKES NO OTHER WARRANTIES, EXPRESSED, IMPLIED OR STATUTORY, INCLUDING ANY IMPLIED WARRANTY OF MERCHANTABILITY.

THE REMEDY PROVIDED UNDER THIS WARRANTY SHALL BE THE SOLE, EXCLUSIVE AND ONLY REMEDY AVAILABLE TO THE PURCHASER AND IN NO CASE SHALL THE COMPANY BE SUBJECT TO ANY OTHER OBLIGATIONS OR LIABILITIES. UNDER NO CIRCUMSTANCES SHALL THE COMPANY BE LIABLE FOR ANY SPECIAL, INDIRECT, INCIDENTAL OR CONSEQUENTIAL DAMAGES, EXPENSES, LOSSES OR DELAYS HOWSOEVER CAUSED.

No statement, representation, agreement or understanding, oral or written, made by any agent, distributor, representative, or employee of the Company which is not contained in this Warranty will be binding upon the Company unless made in writing and executed by an officer of the Company.

This warranty shall not be effective as to any claim which is not presented within 30 days after the date upon which the product is claimed not to have been as warranted. Any action for breach of this warranty must be commenced within one year after the date upon which the cause of action occurred.

Any adjustment made pursuant to this warranty shall not be construed as an admission by the Company that any product was not as warranted.