



13-9-591
Version: 11
October 8, 2012



**ELECTRA-SAVER®
ELECTRA-SAVER II®
STATIONARY
BASE-MOUNTED COMPRESSORS**

AUTO SENTRY® -- ES+ CONTROLS

MODELS

**EAU99Q – EBU99C
200 HP**

PARTS LIST

MAINTAIN COMPRESSOR RELIABILITY AND PERFORMANCE WITH GENUINE GARDNER DENVER® COMPRESSOR PARTS AND SUPPORT SERVICES

Gardner Denver® Compressor genuine parts, manufactured to design tolerances, are developed for optimum dependability – specifically for Gardner Denver compressor systems. Design and material innovations are the result of years of experience with hundreds of different compressor applications. Reliability in materials and quality assurance is incorporated in our genuine replacement parts.

Your authorized Gardner Denver Compressor distributor offers all the backup you'll need. A worldwide network of authorized distributors provides the finest product support in the air compressor industry.

Your authorized distributor can support your Gardner Denver air compressor with these services:

1. Trained parts specialists to assist you in selecting the correct replacement parts.
2. Factory warranted new and remanufactured rotary screw airends. Most popular model remanufactured airends are maintained in stock at the factory, for purchase on an exchange basis with liberal core credit available for the replacement unit.
3. A full line of factory tested AEON™ compressor lubricants specifically formulated for use in Gardner Denver compressors.
4. Repair and maintenance kits designed with the necessary parts to simplify servicing your compressor.

Authorized distributor service technicians are factory trained and skilled in compressor maintenance and repair. They are ready to respond and assist you by providing fast, expert maintenance and repair services.

To Contact Gardner Denver or locate your local distributor:

visit: www.contactgd.com/compressors

or

call: (217)222-5400

INSTRUCTIONS FOR ORDERING REPAIR PARTS

When ordering parts, specify Compressor MODEL, Method of Cooling, HORSEPOWER and SERIAL NUMBER (see nameplate on unit). The Airend Serial Number is also stamped on top of the discharge bearing carrier casting.

All orders for Parts should be placed with the nearest authorized distributor.

Where NOT specified, quantity of parts required per compressor or unit is one (1); where more than one is required per unit, quantity is indicated in parenthesis. SPECIFY EXACTLY THE NUMBER OF PARTS REQUIRED.

DO NOT ORDER BY SETS OR GROUPS.

To determine the Right-Hand and Left-Hand side of a compressor, stand at the motor end and look toward the compressor. Right-Hand and Left- Hand are indicated in parenthesis following the part name, i.e. (RH) and (LH), when appropriate.

TOTAL PRODUCT SUPPORT – GARDNER DENVER’S CONTINUING COMMITMENT TO YOUR AIR COMPRESSOR PERFORMANCE

Commitment to total product support continues long after the purchase of your quality Gardner Denver rotary screw compressor.

Gardner Denver original parts incorporate years of experience and improvements in design, materials and quality assurance. Maintaining your compressor investment with Gardner Denver parts will insure protection for the air compressor unit and long, dependable service life.

Your authorized Gardner Denver compressor distributor maintains a complete stock of all common maintenance parts, factory approved AEON lubricants, and Gardner Denver factory warranted exchange airends. In addition, authorized distributor technicians are factory trained, and can provide complete diagnostic, compressor maintenance and repair services.

This manual is designed to assist you in maintaining high performance and receiving many years of dependable service you expect from your Gardner Denver compressor.

REMANUFACTURED AIRENDS

Whenever an airend requires replacement or repair, Gardner Denver offers an industry unique, factory remanufactured airend exchange program. From its modern Remanufacturing Center, Gardner Denver is committed to supplying you with the highest quality, factory remanufactured airends that are guaranteed to save you time and money.

Immediately Available

Repair downtime costs you money, which is why the most popular models are in inventory at all times.

Skilled Craftsmen

Our Remanufacturing assembly technicians average over 20 years experience with air compression products.

Precision Remanufacturing

All potentially usable parts are thoroughly cleaned, inspected and analyzed. Only those parts that can be brought back to original factory specifications are remanufactured. Every remanufactured airend receives a new overhaul kit: bearings, gears, seals, sleeves and gaskets.

Extensive Testing

Gardner Denver performs testing that repair houses just don't do. Magnaflux and ultrasonic inspection spot cracked or stressed castings, monochromatic light analysis exposes oil leaks, and coordinate measurement machine inspects to +/- .0001", insuring that all remanufactured airends meet factory performance specifications.

Warranty

Gardner Denver backs up every remanufactured airend with a warranty...27 months from purchase.

Gardner Denver remanufactured airends deliver *quality without question...year in and year out.*

Call Gardner Denver for information on the airend exchange program and the name of your authorized distributor.

Phone Number: 217-222-5400 or
Fax: 217-224-7814

TABLE OF CONTENTS

Maintain Compressor Reliability And Performance With Genuine Gardner Denver Compressor Parts And Support Services	1
Instructions For Ordering Repair Parts.....	1
Total Product Support – Gardner Denver's Continuing Commitment To Your Air Compressor Performance	2
Remanufactured Airends	2
Airend Selection And Repair Kits	4
Cylinder Group (Turn Valve)	5
Cylinder, Base Load.....	6
Cylinder Group	7
Discharge Housing Group – All Models	8, 9
Discharge Flange Mounting Group	10
Bearing Cover Plate Group	11
Oil Seal Detail	12
Miscellaneous Parts Group	13
Turnvalve Spacer Group	14
Turn Valve – EAU	15
Inlet Valve	16
Air Filter & Mounting.....	17
Separator Housing	18
Separator Group	19
Discharge Piping.....	20
Oil Return Line	21
Oil Inlet Tube.....	22
Filter Assembly.....	23
Cooler Group.....	24, 25
Water Cooled Heat Exchanger – With Aftercooler	26, 27
Water Cooled Heat Exchanger – Without Aftercooler	28, 29
Repair Parts For Heat Exchanger And Aftercooler.....	30
Miscellaneous Electrical Parts.....	31
Control Schematic.....	32, 33
Minimum Pressure/Check Valve	34
Turn Valve Actuator – (EAU Only)	35
Enclosure Vent Fan Assembly	36
Enclosure	37
Enclosure – Hardware.....	38
Enclosure – Air Cooled Panels.....	39
Enclosure – Water Cooled Panels	40
Enclosure – Basic	41
Air Cooled Baffle	42
Air Cooled Baffle Hardware.....	43
Enclosure – Water Cooled	44
Compressor Base Group	45
Main Motor Group	46
Motor Group (Main Drive Motors).....	47
Overload Relay Heater Conversion Listing	48
Controller Assembly.....	49
Controller Assembly - Wye Delta Starters.....	50, 51
Controller Assembly - Full Voltage.....	52, 53
Controller Assembly - Less Starter.....	54, 55
Identification And Instruction Group	56, 57
Repair Kits	58, 59

For Operating and Service Instructions see:

SERVICE MANUAL 13-9-666
CONTROLLER MANUAL 13-9-653

AIREND SELECTION AND REPAIR KITS

Model	HP	PSI	Airend w/Inlet Valve	Reman Airend w/Inlet Valve	Bearing Kit *	Gasket Kit	Inlet Valve Kit	Turn Valve Kit	Drive Shaft Seal Kit	Drive Shaft Wear Sleeve Removal & Installation Kit
EAU	200	100	SSUAVABM01S	SSUAVABM01X	331SSU6013	334SSU6013	301EAQ6013	335SSU6013	324SSU6013	302SSU4017
		125	SSUAVABM01S	SSUAVABM01X	331SSU6013	334SSU6013	301EAQ6013	335SSU6013	324SSU6013	302SSU4017
EBU	200	100	SSUDVAAM01S	SSUDVAAM01X	331SSU6013	334SSU6013	301EAQ6013	N/A	324SSU6013	302SSU4017
		125	SSUDVAAM02S	SSUDVAAM01X SSUDVAAM02X	331SSU6013	334SSU6013	301EAQ6013	N/A	324SSU6013	302SSU4017

* When order Bearing Kits, also order Gasket Kit and Drive Shaft Seal Kit.

For listing of Repair Parts included in Kit numbers above, see Repair Kit Section, page 56-57.

Order by Part Number and Description. Reference Numbers are for your convenience only.

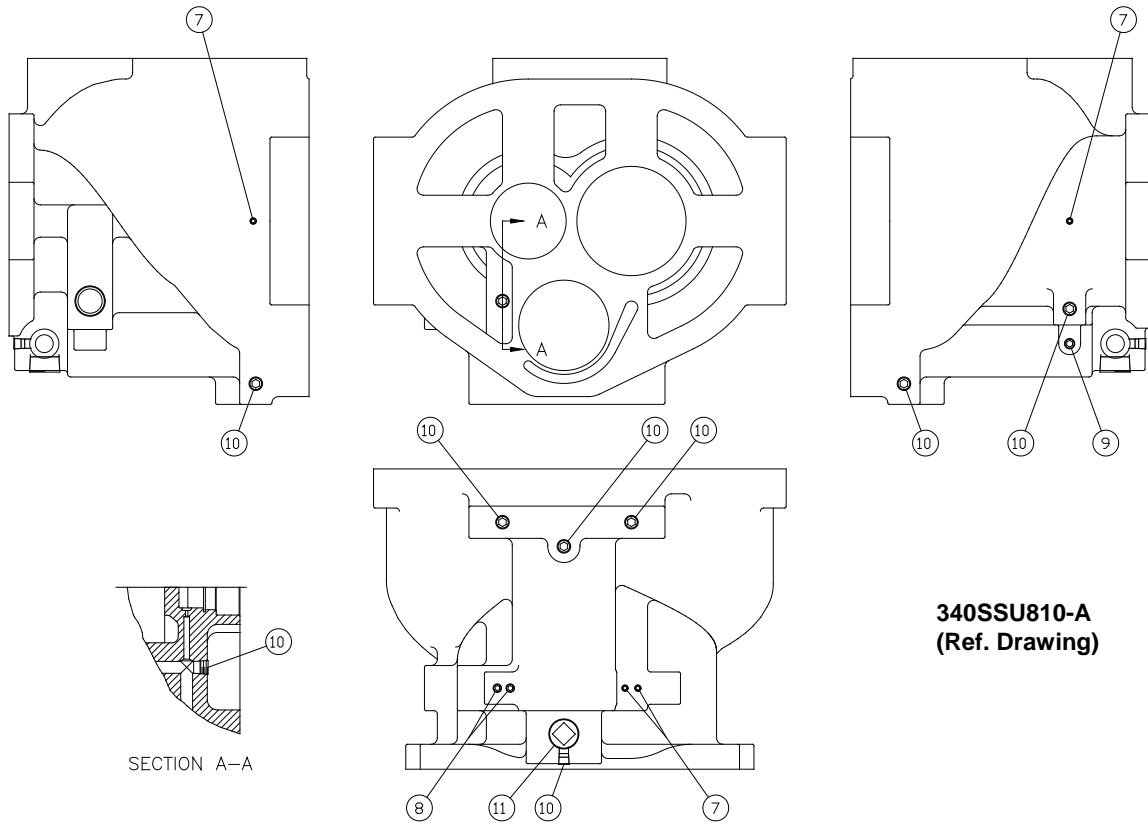

340SSU810-A
(Ref. Drawing)

CYLINDER GROUP (TURN VALVE)

B/M: 300SSU4042

Ref. No.	Name of Part	Qty.	Part No.
7	PLUG	4	64AA5
8	PLUG	2	64AA4
9	PLUG	1	64AA7
10	PLUG	8	64AA3
11	PLUG	1	64B7

Order by Part Number and Description. Reference Numbers are for your convenience only.

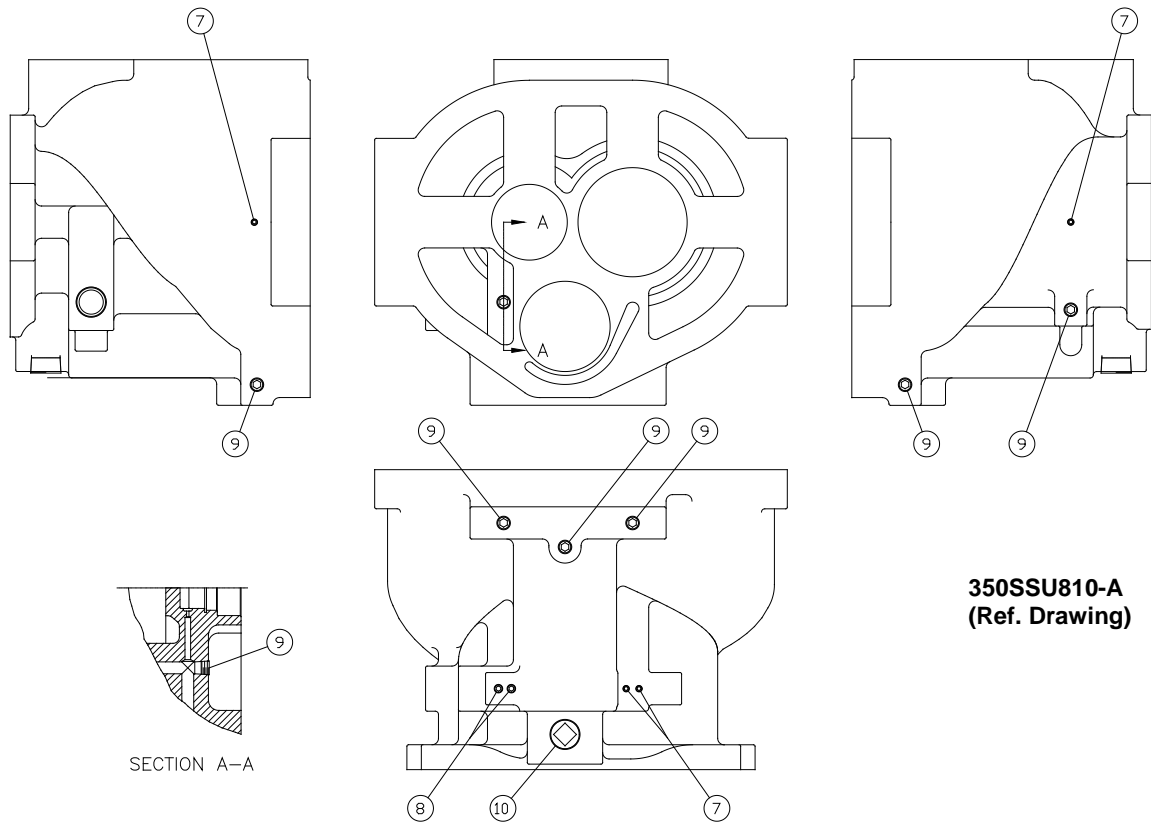

350SSU810-A
(Ref. Drawing)

CYLINDER, BASE LOAD

B/M: 301SSU4042

Ref. No.	Name of Part	Qty.	Part No.
7	PLUG	4	64AA5
8	PLUG	2	64AA4
9	PLUG	7	64AA3
10	PLUG	1	64B7

Order by Part Number and Description. Reference Numbers are for your convenience only.

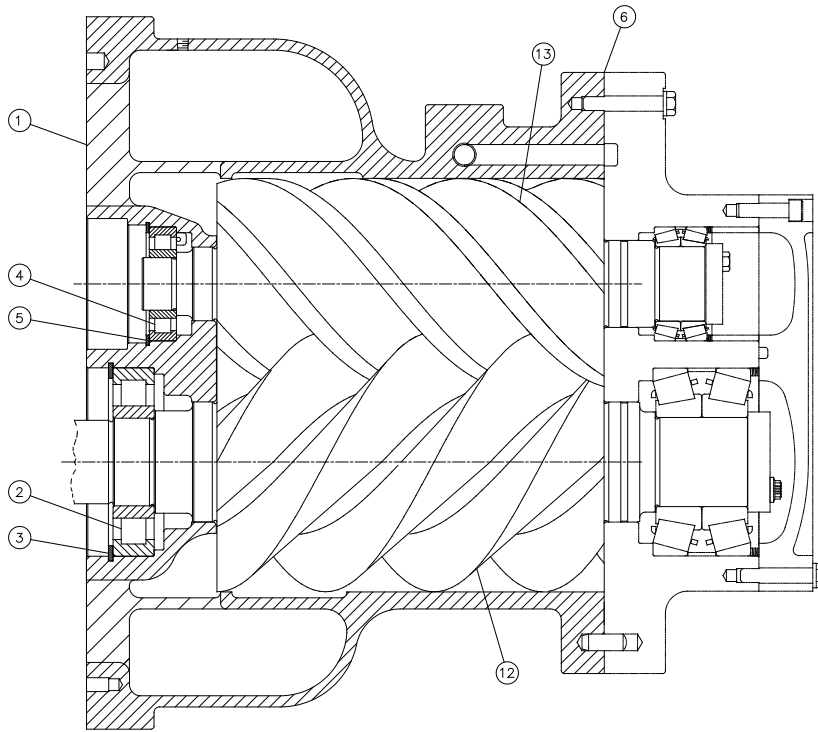

339SSU810-B
(Ref. Drawing)

CYLINDER GROUP

B/M: 300SSU4042
301SSU4042

Ref. No.	Name of Part	Qty.	Part No.
1	CYLINDER-AIR, TURN VALVE	1	**
* 2	BEARING-ROLLER.....	1	12BA52
* 3	RING-RETAINER	1	65W61
* 4	BEARING-ROLLER.....	1	12W34
* 5	RING-RETAINING	1	65W14
6	GASKET-ELIMINATOR.....	1	25BC222

* Parts included in Bearing Kit Part Number 331SSU6013. Refer to page 58.

** Shown for reference only.

DISCHARGE HOUSING GROUP – ALL MODELS

13-9-591 Page 8

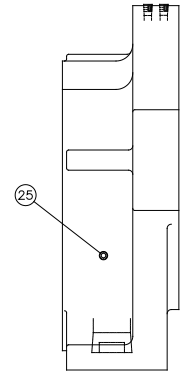
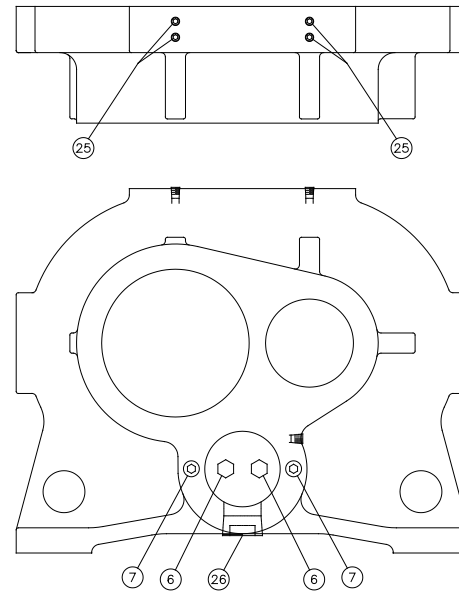
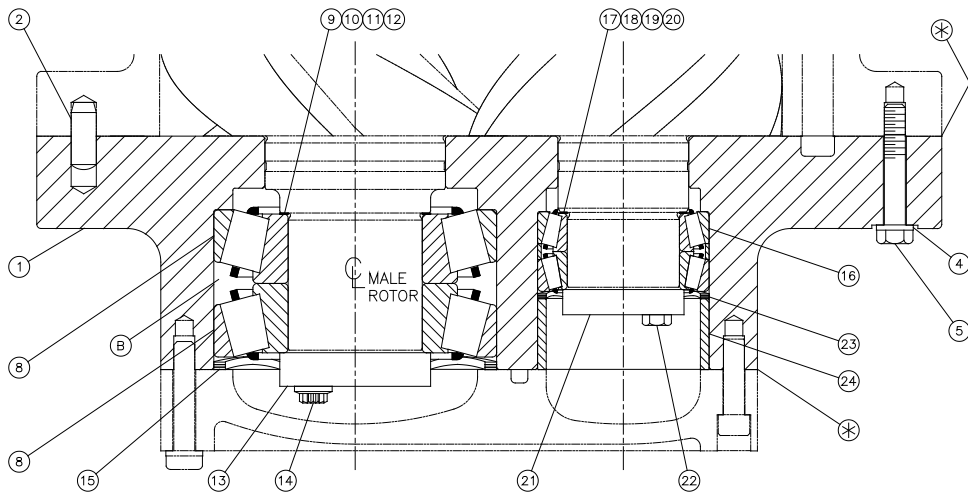

342SSU810-B
(Ref. Drawing)

Order by Part Number and Description. Reference Numbers are for your convenience only.

DISCHARGE HOUSING GROUP – ALL MODELS

B/M: 310SSU4044

Ref. No.	Name of Part	Qty.	Part No.
1	HOUSING-BEARING	1	**
2	PIN-DOWEL	1	**
3	PIN (not shown).....	1	**
4	LOCKWASHER	24	**
5	SCREW	22	**
6	SCREW	2	**
7	SCREW	2	**
* 8	BEARING	2	12BA79
*** 9	SHIM-SET	3	77H108002
*** 10	SHIM-SET	3	77H108003
*** 11	SHIM-SET	3	77H108005
*** 12	SHIM-SET	2	77H108015
13	PLATE-BEARING RETAINER.....	1	**
14	SCREW	3	**
* 15	SPRING.....	1	78W110
* 16	BEARING	1	12BA192
*** 17	SHIM	3	77H50002
*** 18	SHIM	3	77H50003
*** 19	SHIM	3	77H50005
*** 20	SHIM	2	77H50015
21	PLATE-BEARING RETAINER.....	1	**
22	SCREW	3	**
* 23	SPRING.....	1	78W90
24	SPACER.....	1	**
25	PLUG (not shown).....	5	**
26	PLUG (not shown).....	1	**

* Parts included in Bearing Kit Part Number 331SSU6013, page 58.
 ** For reference only.
 *** Parts included in Gasket Kit Part Number 334SSU6013, page 59.

Order by Part Number and Description. Reference Numbers are for your convenience only.

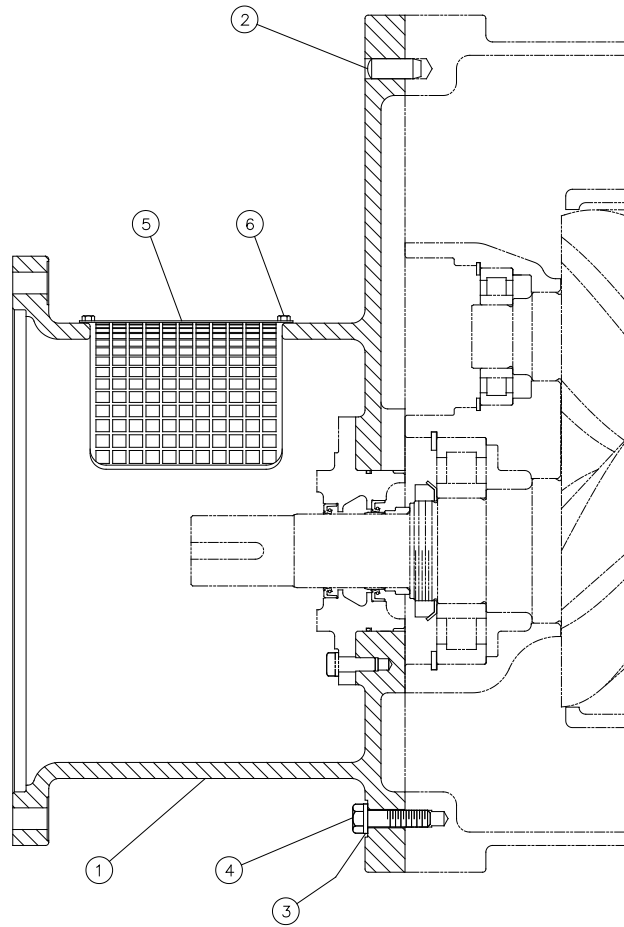

344SSU810-A
(Ref. Drawing)

DISCHARGE FLANGE MOUNTING GROUP

B/M: 301SSU4017

Ref. No.	Name of Part	Qty.	Part No.
1	ADAPTOR	1	301SSU170
2	PIN-DOWEL	2	62M112
3	LOCKWASHER	20	95B7
4	SCREW	20	655EF100
5	GUARD-COUPLING.....	1	301SSU339
6	SCREW	4	75LM51
7	PLUG (not shown).....	1	64AA5

Order by Part Number and Description. Reference Numbers are for your convenience only.

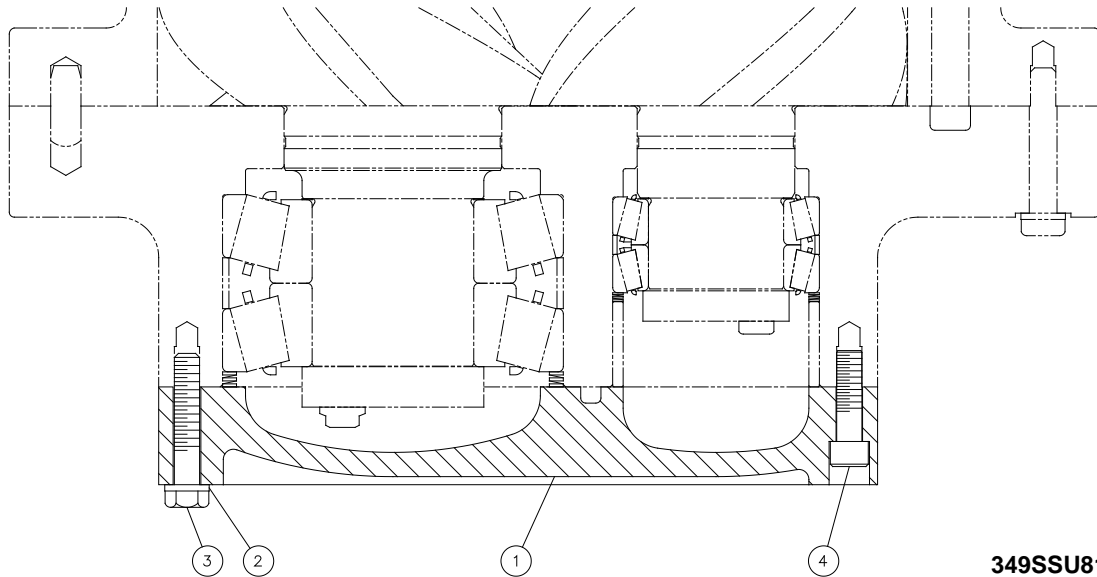

349SSU810-A
(Ref. Drawing)

BEARING COVER PLATE GROUP

B/M: 300SSU4037

Ref. No.	Name of Part	Qty.	Part No.
1	PLATE-BEARING COVER.....	1	304SSU315
2	LOCKWASHER.....	10	95B7
3	SCREW.....	10	655EF130
4	SCREW.....	9	75P197

Order by Part Number and Description. Reference Numbers are for your convenience only.

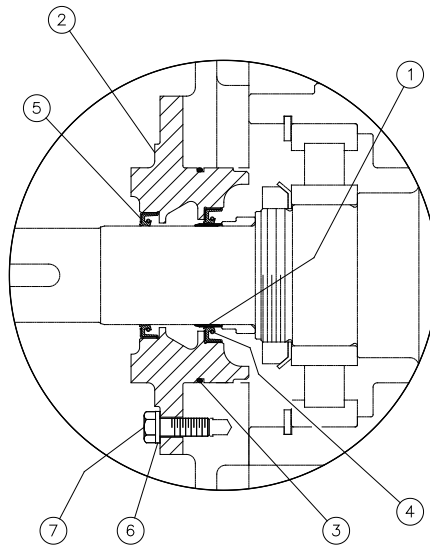

348SSU810 – A
(Ref. Drawing)

OIL SEAL DETAIL

B/M: 302SSU6029

Ref. No.	Name of Part	Qty.	Part No.
* 1	SLEEVE-WEAR.....	1	80M28
2	HOUSING-SEAL	1	203SSU362
* 3	O-RING.....	1	25BC205
* 4	SEAL-OIL.....	1	60DD571
* 5	SEAL-OIL.....	1	60DD689
6	LOCKWASHER	6	95B5
7	SCREW	6	655EE060
* 8	VALVE-CHECK (not shown)	1	90AR923

* Parts included in Oil Seal Kit Part Number 324SSU6013, page 59

Order by Part Number and Description. Reference Numbers are for your convenience only.

346SSU810-A
(Ref. Drawing)

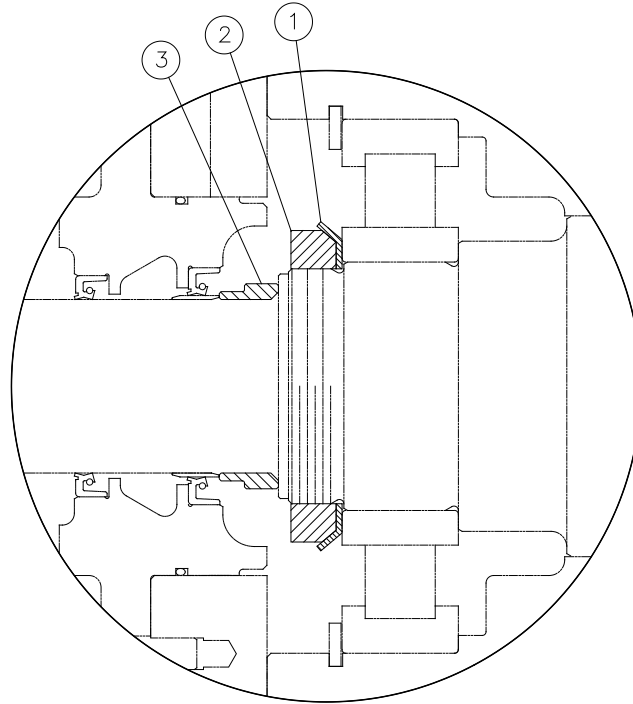

MISCELLANEOUS PARTS GROUP

B/M: 306SSU4013

Ref. No.	Name of Part	Qty.	Part No.
1	LOCKWASHER-BEARING.....	1	95N19
2	LOCKNUT.....	1	50Z19
3	SPACER-SHAFT.....	1	300SSU600

Order by Part Number and Description. Reference Numbers are for your convenience only.

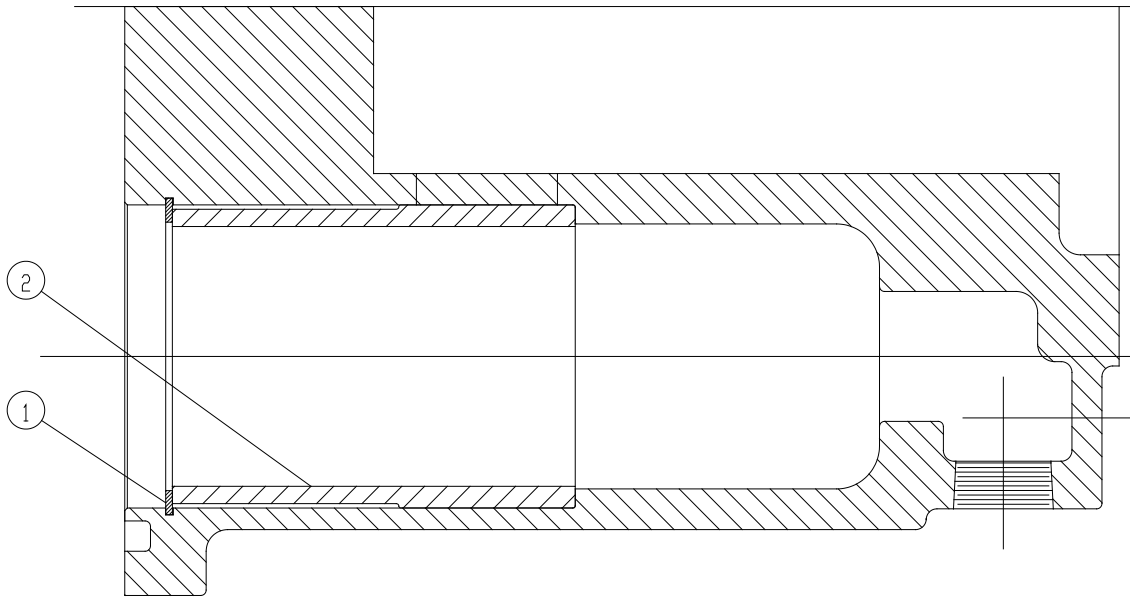

327SSU810-A
(Ref. Drawing)

**TURNVALVE SPACER GROUP
(SSUDVAAM01S AIREND ONLY)**

B/M: 316SSU4049

Ref. No.	Name of Part	Qty.	Part No.
1	RING-RETAINING	1	100522
2	SPACER	1	305SSU144

Order by Part Number and Description. Reference Numbers are for your convenience only.

341SSU810-A
(Ref. Drawing)

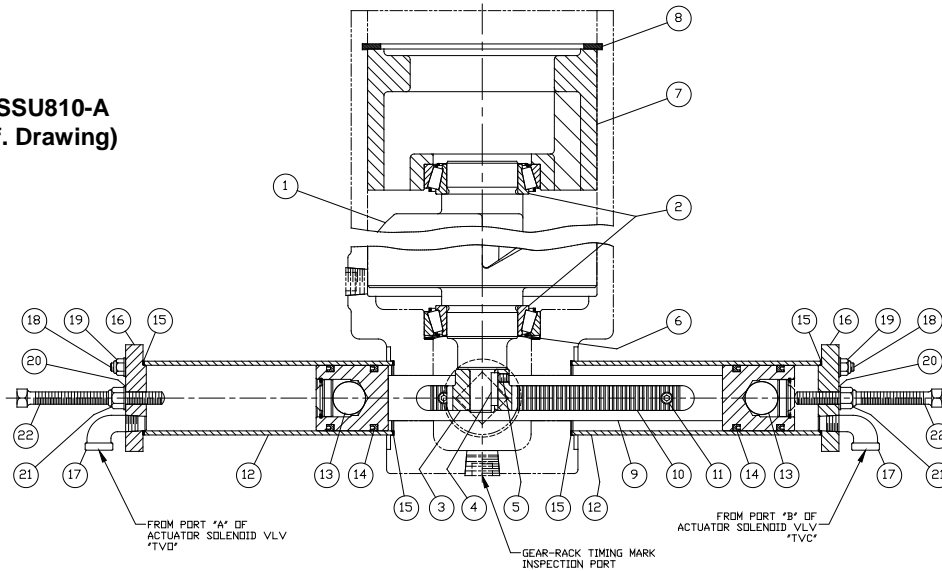

**TURN VALVE – EAU
(SSUAVBM01S ONLY)**

B/M: 300SSU4052

Ref. No.	Name of Part	Qty.	Part No.
1	VALVE.....	1	203SSU238
* 2	BEARING-ROLLER.....	2	12BA51
3	GEAR-AUXILIARY.....	1	200SSU031
* 4	KEY.....	1	35C114
5	SCREW.....	1	76G21P
* 6	SPRING.....	1	78W50
7	RETAINER.....	1	207SSU205
8	RING-RETAINING.....	1	100522
9	SHAFT-CONTROL.....	1	200SSU081
10	RACK.....	1	200SSU360
11	SCREW.....	2	75P11N
12	CYLINDER.....	2	200SSU082
13	GROUP-PISTON.....	2	300SSU4056
	PISTON-CONTROL.....	1	201SSU084
*	BUMPER.....	1	32E15
*	PLATE-RETAINER.....	1	300SSU168
*	RING-RETAINING.....	1	74D49
* 14	PACKING-RING.....	4	60AM46
* 15	GASKET.....	4	25BC138N
16	HEAD-CONTROL CYLINDER.....	2	302SSY083
17	ELBOW.....	2	64D2G
18	STUD.....	8	79AL5
19	NUT.....	8	50AW24
* 20	SEAL.....	2	60DD801
21	LOCKNUT.....	2	50AW38
22	SCREW.....	2	76D49

* Parts included in Periodic Overhaul Kit Part Number 335SSU6013, page 59

Order by Part Number and Description. Reference Numbers are for your convenience only.

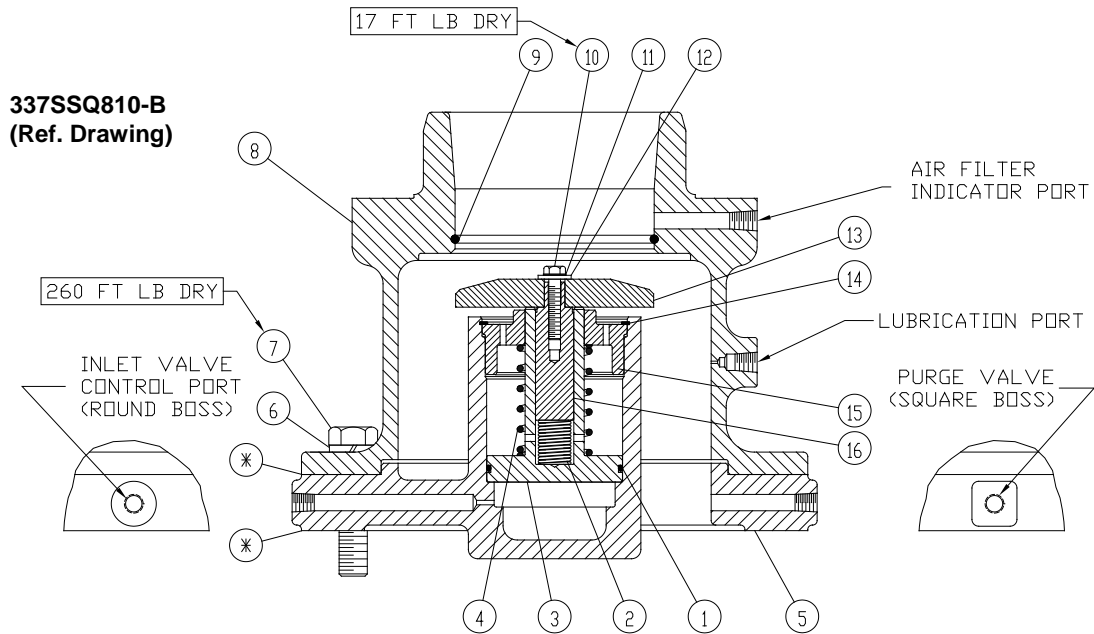

(*) DESIGNATES JOINTS REQUIRING GASKET ELIMINATOR
REFER TO RELATED BILLS OF MATERIAL FOR PART NUMBER

INLET VALVE

B/M: 201SSQ4030

Ref. No.	Name of Part	Qty.	Part No.
** 1	O-RING.....	1	25BC298
** 2	SPRING.....	1	78W62
3	PISTON-INLET VALVE.....	1	201SSQ043
** 4	SPRING.....	1	78W61
5	HOUSING-INLET.....	1	204SSQ041
6	LOCKWASHER.....	8	95B8
7	SCREW.....	8	655EG120
8	SEAT.....	1	202SSQ256
** 9	O-RING.....	1	25AM30
10	SCREW.....	1	75A102
11	LOCKWASHER.....	1	95H57
12	WASHER.....	1	95A2
13	VALVE-INLET.....	1	201SSQ044
**14	RING-RETAINING.....	1	74D89
15	RETAINER.....	1	200SSQ205
16	GUIDE-VALVE.....	1	201SSQ483

** Parts included in Periodic Maintenance Kit Number 301EAQ6013. Refer to page 58

Order by Part Number and Description. Reference Numbers are for your convenience only.

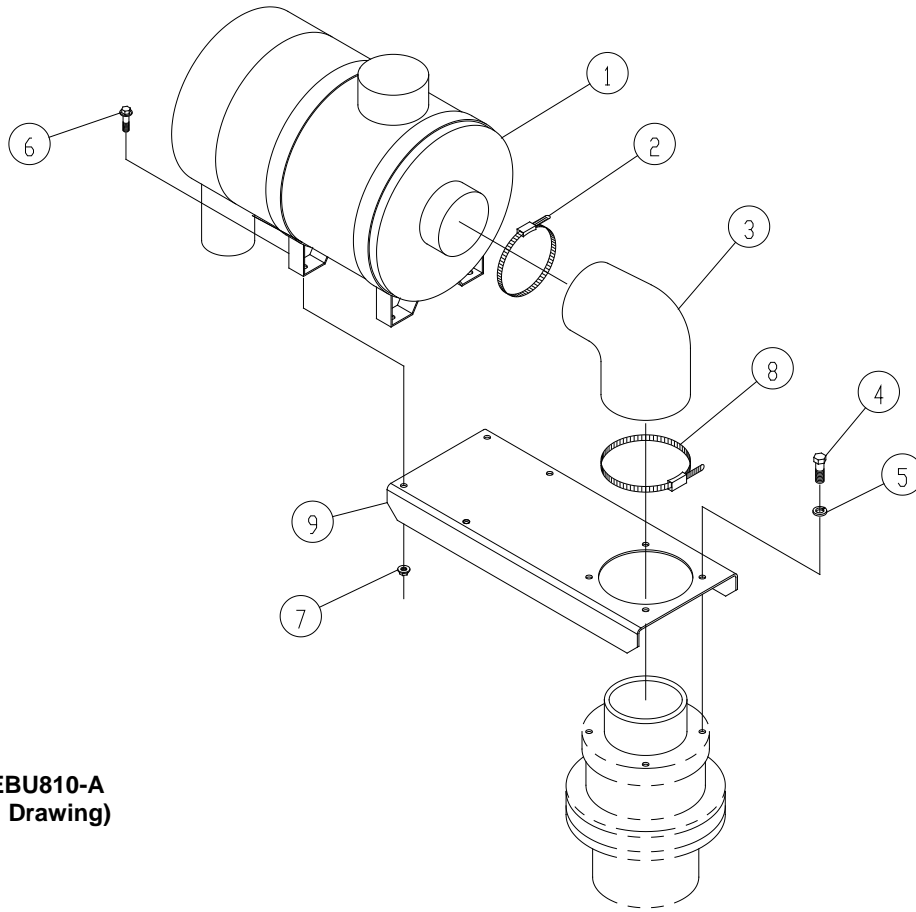

309EBU810-A
(Ref. Drawing)

AIR FILTER & MOUNTING

B/M: 303EBU4017

Ref. No.	Name of Part	Qty.	Part No.
* 1	FILTER-AIR	1	5L354
2	CLAMP	1	29Z16
3	HOSE	1	29Z472
4	SCREW	4	655EE040
5	LOCKWASHER	4	95B5
6	SCREW	4	75LM135
7	NUT	4	50AW5
8	CLAMP	1	2009499
9	BRACKET-FILTER	1	300EBU389

* Air Filter Element Part Number is 2118361.

Order by Part Number and Description. Reference Numbers are for your convenience only.

209EDM810-A
(Ref. Drawing)

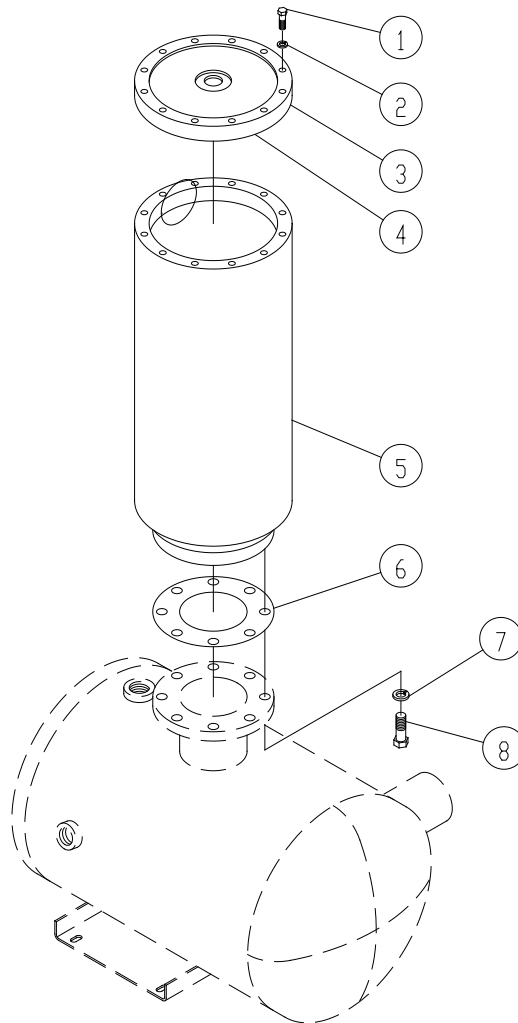

SEPARATOR HOUSING

B/M: 201EDM4018

Ref. No.	Name of Part	Qty.	Part No.
1	SCREW	12	655EE090
2	LOCKWASHER.....	12	95B5
3	COVER.....	1	200EDM225
4	GASKET-ELIMINATOR.....	1	25BC222
5	HOUSING.....	1	200EDM405
6	GASKET	1	25C2719N
7	LOCKWASHER.....	8	95B8
8	SCREW	8	655EG080

Order by Part Number and Description. Reference Numbers are for your convenience only.

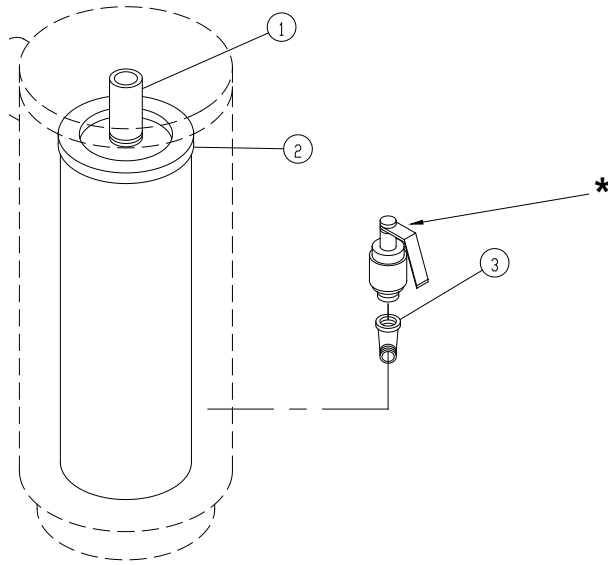

203EDM810-A
(Ref. Drawing)

SEPARATOR GROUP

B/M: 200EDP4013

Ref. No.	Name of Part	Qty.	Part No.
1	SPACER	1	201EDM392
** 2	OIL SEPARATOR.....	1	VP1040693
3	ELBOW	1	64D8G
*	RELIEF VALVE		
	100 PSI		90AR510
	125 PSI		90AR532

** For repair, order Separator Repair Kit Part Number 305EBQ6013. Refer to page 58.

Order by Part Number and Description. Reference Numbers are for your convenience only.

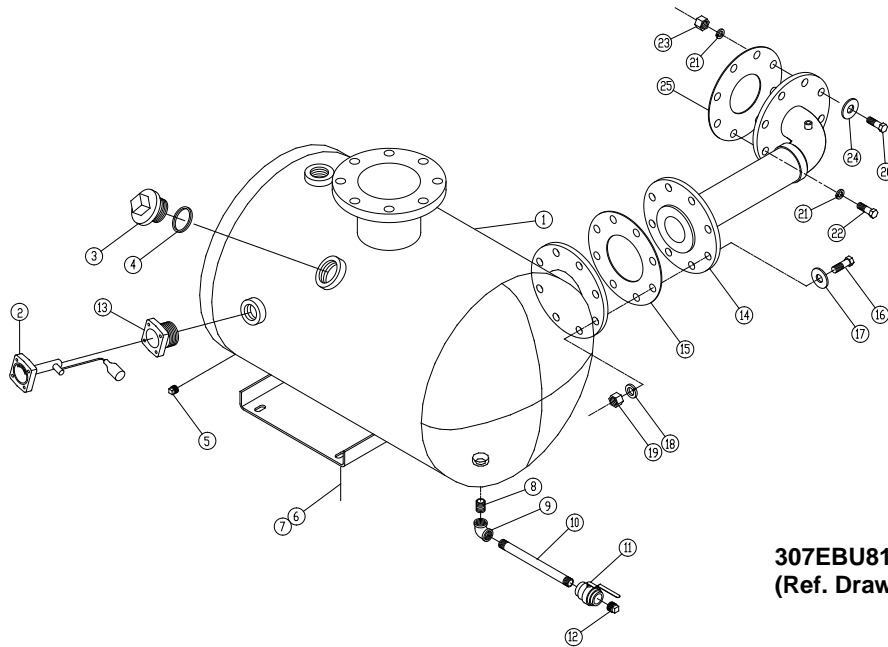

307EBU810-A
(Ref. Drawing)

DISCHARGE PIPING

B/M: 300EBU4018

Ref. No.	Name of Part	Qty.	Part No.
1	RESERVOIR-OIL	1	303EAQ037
2	GAUGE	1	300EBM303
3	COVER	1	200SPF156
4	O-RING	1	25BC900
5	PLUG	1	64AA5
6	SCREW	4	75LM135
7	NUT	4	50AW35
8	NIPPLE	1	63F1G
9	ELBOW	1	64C4G
10	NIPPLE	1	63F15G
11	VALVE-BALL	1	90AR360
12	PLUG	1	64AA7
13	ADAPTOR-GAUGE	1	200EDE058
14	MANIFOLD-DISCHARGE	1	300EBU071
15	GASKET	1	25C121N
16	SCREW	8	655EF120
17	WASHER	8	95A7
18	LOCKWASHER	8	95B7
19	NUT	8	50B7
20	SCREW	2	655EG140
21	LOCKWASHER	8	95B8
22	SCREW	6	655EG080
23	NUT	2	50B8
24	WASHER	2	95A8
25	GASKET	1	25C144N

Order by Part Number and Description. Reference Numbers are for your convenience only.

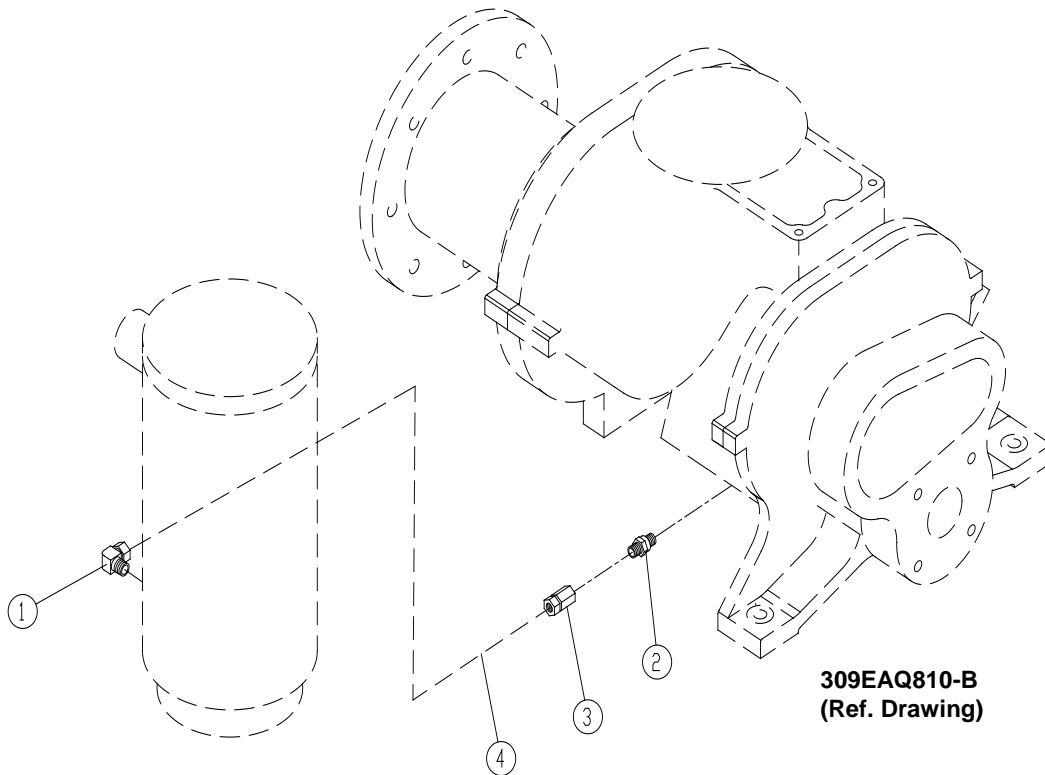

OIL RETURN LINE

B/M: 308EAQ4017

Ref. No.	Name of Part	Qty.	Part No.
1	TUBE FITTING	1	86E220
* 2	VALVE-CHECK	1	90AR261
3	TUBE FITTING	1	86E218
4	TUBE (IN FEET).....	3	85K3

* Part included in Pneumatic Control Kit Part Number 302EAQ6013. Refer to page 58.

Order by Part Number and Description. Reference Numbers are for your convenience only.

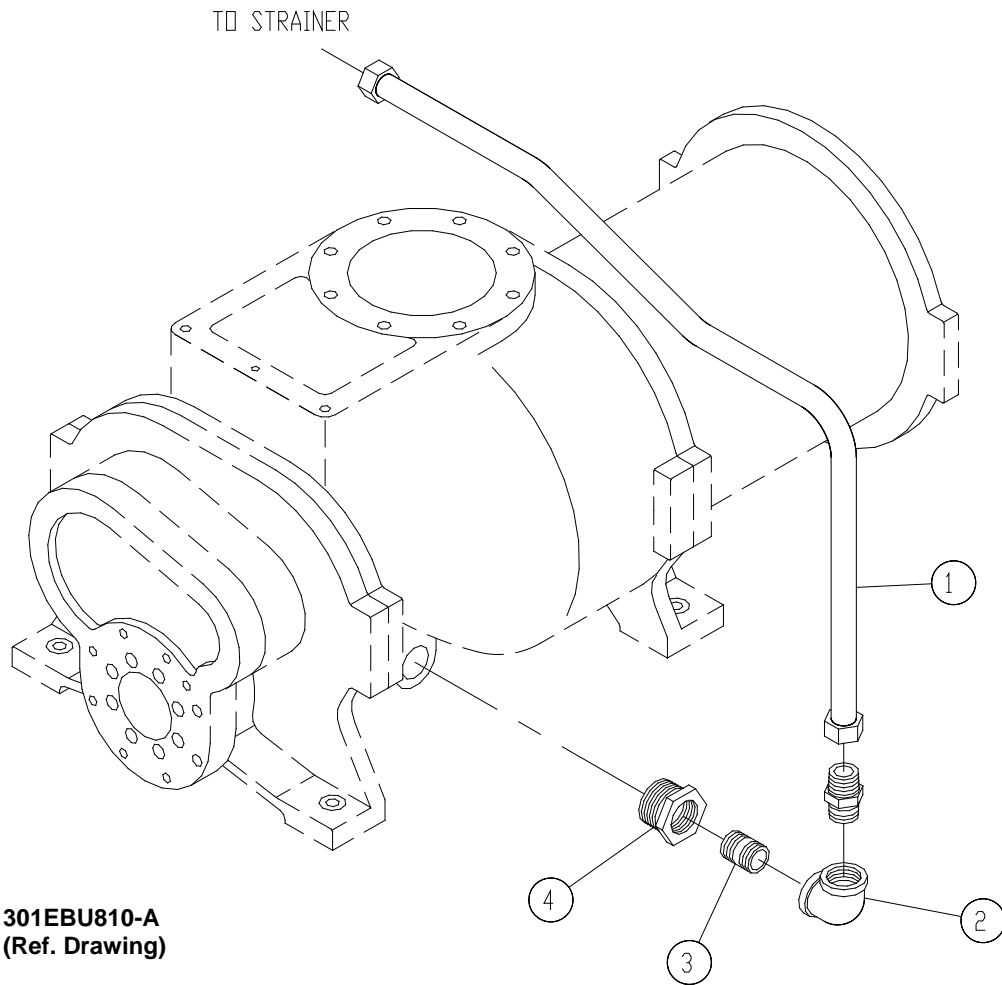

301EBU810-A
(Ref. Drawing)

OIL INLET TUBE

B/M: 302EBU4017

Ref. No.	Name of Part	Qty.	Part No.
1	TUBE WITH FITTINGS	1	301EBU863
2	ELBOW	1	64C8G
3	NIPPLE	1	63K20G
4	BUSHING-PIPE	1	64EB304

Order by Part Number and Description. Reference Numbers are for your convenience only.

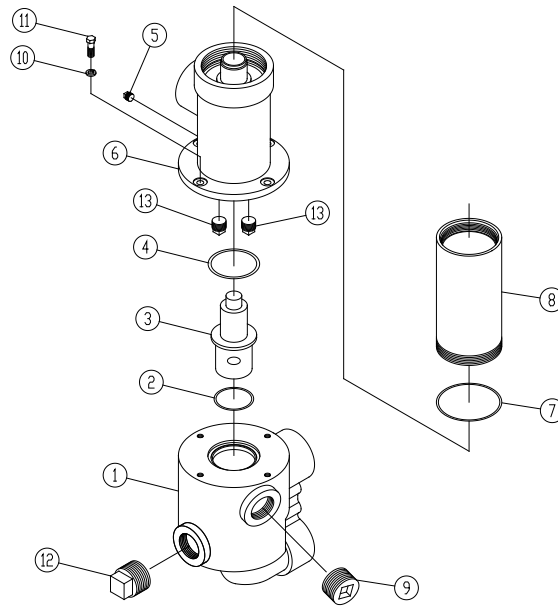

333EAU810-B
(Ref. Drawing)

**FILTER ASSEMBLY
(WITH 150° ELEMENT – STANDARD)**

**B/M: 303EAQ2045 (150° F)
304EAQ2045 (180° F)**

Ref. No.	Name of Part	Qty.	Part No.
1	MANIFOLD-OIL MIXING VALVE ELEMENT	1	200EAU116
2	O-RING.....	1	25BC127
3	ELEMENT	1	
	STANDARD 150° F.....	1	2117382
	OPTIONAL 140° F	1	2117381
	OPTIONAL 160° F	1	2117383
	OPTIONAL 180° F	1	2117384
4	O-RING.....	1	25BC175
5	PLUG	1	64AC2
6	MANIFOLD-OIL.....	1	201EAU116
7	O-RING.....	1	25BC380
* 8	BODY-OIL FILTER	1	200EDM032
9	PLUG	1	64B7
10	LOCKWASHER	4	95B3
11	SCREW	4	655ED050
12	PLUG	1	64AA2
13	PLUG	2	2118347

* For Repair of Filter Element, order Part Number 2118342.

COOLER GROUP

308EBU810-B
(Ref. Drawing)

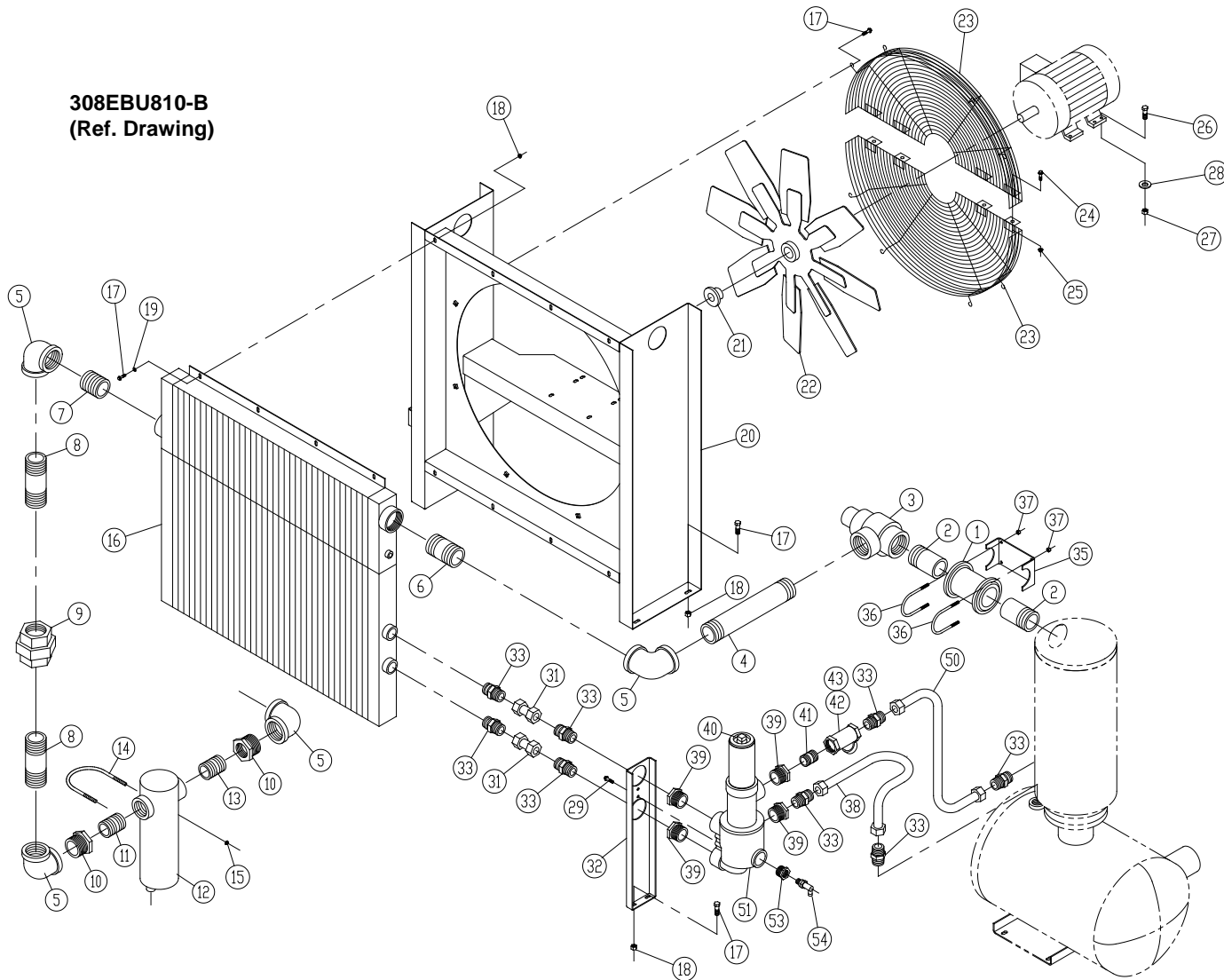

Order by Part Number and Description. Reference Numbers are for your convenience only.

COOLER GROUP

B/M: 304EBU4003; 305EBU4003
308EAQ4013; 309EAQ4013

Ref. No.	Name of Part	Qty.	Part No.	Ref. No.	Name of Part	Qty.	Part No.
* 1	COUPLING-FLEXIBLE	1	64EB803	23	GUARD-FAN	1	200EDM393
2	NIPPLE	2	63AJ48X50G	24	SCREW	4	75LM50
3	VALVE-MINIMUM PRESSURE	1	201EDM527	25	NUT	4	50AW4
4	NIPPLE	1	63P21G	26	SCREW	4	75LM78
5	ELBOW	4	64C10G	27	NUT	4	50AW5
6	NIPPLE	1	63P10G	28	WASHER	4	95W15
7	NIPPLE	1	63P1G	29	SCREW	2	75LM51
8	NIPPLE	2	63P17G	31	TUBE WITH FITTINGS	2	311EAQ863
9	UNION	1	64Z21	32	BRACKET (FORMED)	1	300EAQ142
10	BUSHING-PIPE	2	64E33	33	CONNECTOR-TUBE	8	86H141
11	NIPPLE	1	63M3G	35	BRACKET-PIPE	1	200EAQ108
** 12	SEPARATOR-MOISTURE	1	83C92	36	U-BOLT	2	15U108
13	NIPPLE	1	63M3G	37	NUT	4	50AW5
14	U-BOLT	1	15U75	38	TUBE WITH FITTINGS	1	310EAQ863
15	NUT	2	50AW35	39	BUSHING-PIPE	4	64EB304
16	COOLER-OIL/AIR	1	300EDP201	∇ 40	FILTER-OIL	1	300EAQ369
	COOLER-OIL/AIR (SEACOAST)	1	301EDP201	41	NIPPLE	1	63K20G
17	SCREW	22	75LM51	*** 42	STRAINER	1	82E49
18	NUT	14	50AW5	43	PLUG	1	64AA3
19	WASHER	8	95A3	50	TUBE ASSEMBLY	1	See Page 22
20	SUPPORT	1	200EDM165	51	FILTER ASSEMBLY (150°) See Page 23...	1	303EAQ2045
21	BUSHING-HUB	1	22G2		FILTER ASSEMBLY (180°) See Page 23...	1	304EAQ2045
22	FAN	1	200EDP701	53	BUSHING-PIPE	1	64E61
				54	OIL SAMPLING VALVE	1	86N345

* For Repair Order (2) 2117161 Gaskets.

** Repair Parts Kits for Moisture Separator: 2117587 – Valve & Seat Assembly; 2117588 – Cover Gasket; 2117589 – Float & Spindle.

*** Repair Parts for Strainer (100 Mesh Screen): 2118378; Blow-Off Bushing: 2118381.

∇ Repair Element 2118342.

NOTE: For motor part number, see page 47.

WATER COOLED HEAT EXCHANGER – WITH AFTERCOOLER

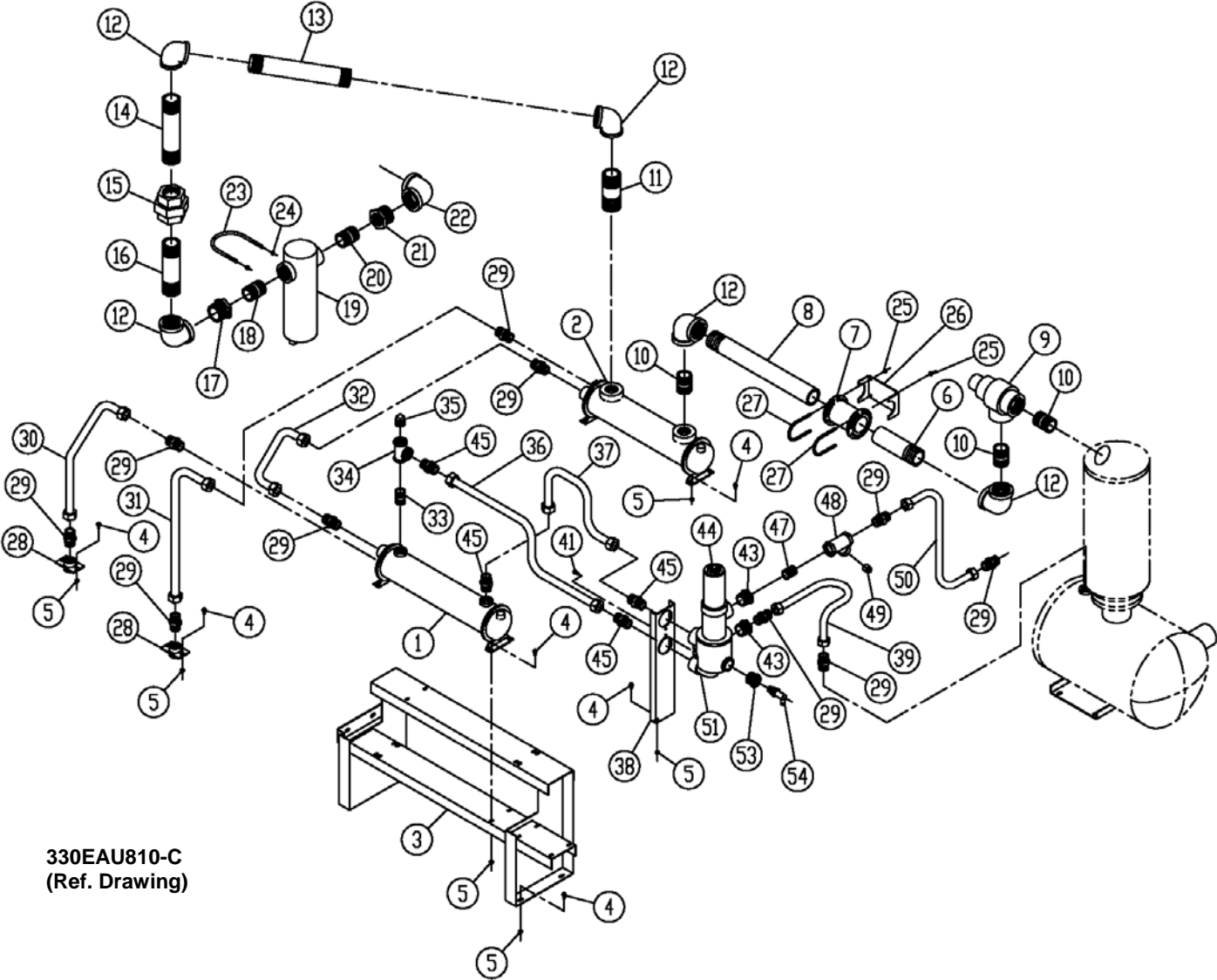

330EAU810-C
(Ref. Drawing)

Order by Part Number and Description. Reference Numbers are for your convenience only.

WATER COOLED HEAT EXCHANGER – WITH AFTERCOOLER

B/M: 300EBU4003; 301EBU4003
308EAQ4013; 309EAQ4013

Ref. No.	Name of Part	Qty.	Part No.	Ref. No.	Name of Part	Qty.	Part No.
1	HEAT EXCHANGER (Fresh Water)..	1	200EAU349	25	NUT-FLANGED.....	4	50AW5
	HEAT EXCHANGER (Salt Water).....	1	203EAU349	26	BRACKET-PIPE.....	1	200EAQ108
2	AFTERCOOLER (Fresh Water).....	1	204EAU292	27	U-BOLT.....	2	15U108
	AFTERCOOLER (Salt Water).....	1	206EAU292	28	MANIFOLD-WATER.....	2	200EDM072
3	SUPPORT.....	1	300EAQ165	29	CONNECTOR-TUBE.....	10	86H141
4	SCREW-FLANGED.....	18	75LM51	30	TUBE WITH FITTINGS.....	1	323EAU863
5	NUT-FLANGED.....	18	50AW5	31	TUBE WITH FITTINGS.....	1	321EAU863
6	NIPPLE.....	1	63AJ48X50G	32	TUBE WITH FITTINGS.....	1	324EAU863
*	7 COUPLING-FLEXIBLE.....	1	64EB803	33	NIPPLE.....	1	63L24G
	8 NIPPLE.....	1	63AJ48X234G	34	TEE.....	1	64G1G
	9 VALVE-MINIMUM PRESSURE.....	1	201EDM527	+ 35	PLUG.....	1	64B7
	10 NIPPLE.....	3	63P11G	36	TUBE WITH FITTINGS.....	1	325EAU863
	11 NIPPLE.....	1	63P12G	37	TUBE WITH FITTINGS.....	1	326EAU863
	12 ELBOW.....	5	64C10G	38	BRACKET (FORMED).....	1	300EAQ142
	13 NIPPLE.....	1	63N48X200G	39	TUBE WITH FITTINGS.....	1	310EAQ863
	14 NIPPLE.....	1	63P17G	41	SCREW.....	2	75LM51
	15 UNION.....	1	64Z21	43	BUSHING-PIPE.....	2	64EB304
	16 NIPPLE.....	1	63P17G	▽ 44	FILTER – OIL.....	1	300EAQ369
	17 BUSHING-PIPE.....	1	64E33	45	CONNECTOR.....	4	86H142
	18 NIPPLE.....	1	63M3G	47	NIPPLE.....	1	63K20G
**	19 SEPARATOR-MOISTURE.....	1	83C92	*** 48	STRAINER.....	1	82E49
	20 NIPPLE.....	1	63M3G	49	PLUG.....	1	64AA3
	21 BUSHING-PIPE.....	1	64E33	50	TUBE ASSEMBLY.....	1	See Page 22
	22 ELBOW.....	1	64C10G	51	FILTER ASSEMBLY (150°) See Page 23.	1	303EAQ2045
	23 U-BOLT.....	1	15U75		FILTER ASSEMBLY (180°) See Page 23.	1	304EAQ2045
	24 NUT-FLANGED.....	2	50AW35	53	BUSHING-PIPE.....	1	64E61
				54	OIL SAMPLING VALVE.....	1	86N345

* For Repair Order (2) 2117161 Gaskets.

** Repair Parts Kits for Moisture Separator: 2117587 – Valve & Seat Assembly; 2117588 – Cover Gasket; 2117589 – Float & Spindle.

*** Repair Parts for Strainer (100 Mesh Screen): 2118378; Blow-Off Bushing: 2118381.

+ Remove this plug when Optional Water Temperature Regulator is used. This is the temperature probe location.

▽ Repair Element 2118342.

Note: For Repair Part Numbers for Heat Exchangers and Aftercoolers, see page 30.

WATER COOLED HEAT EXCHANGER – WITHOUT AFTERCOOLER

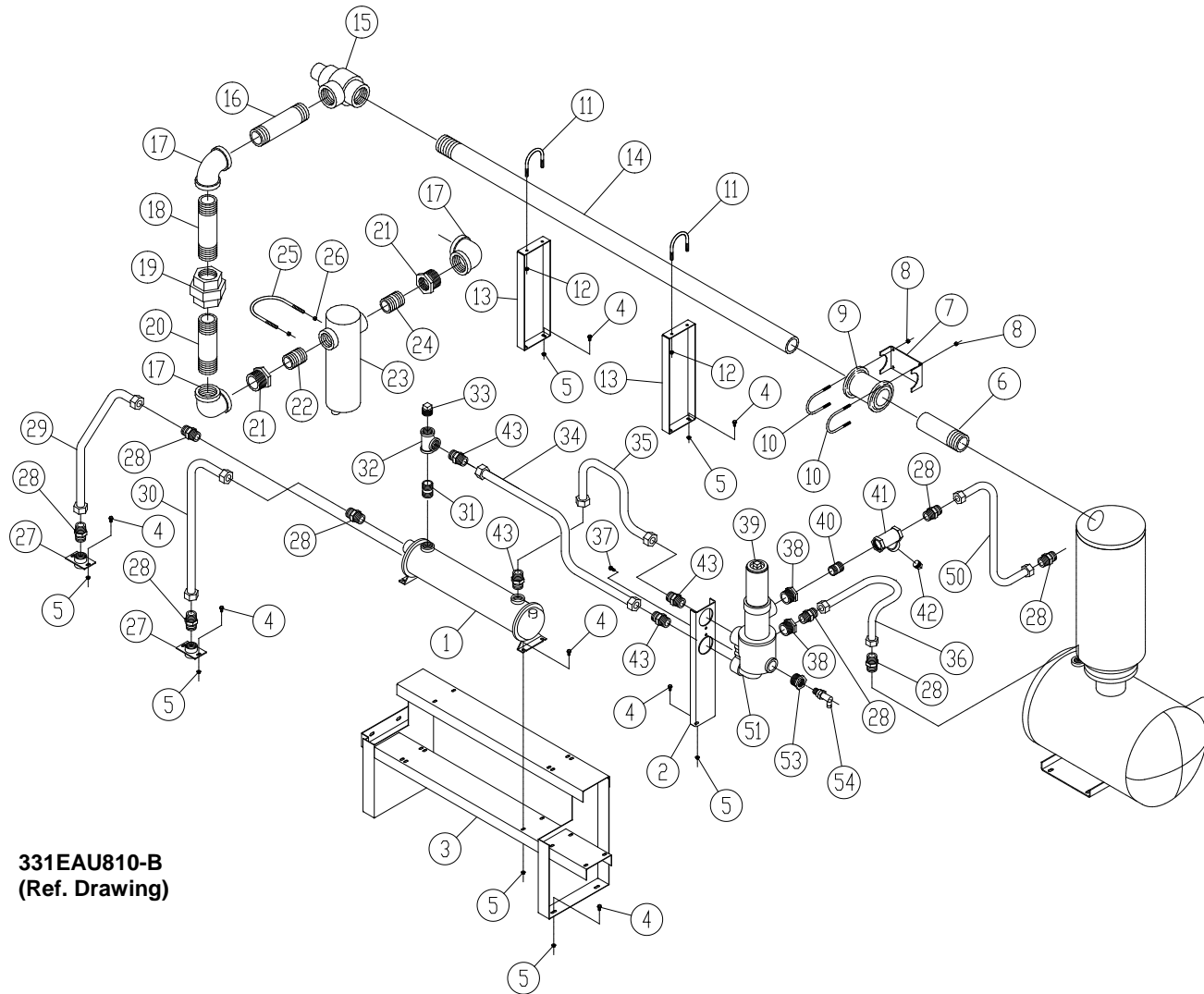

331EAU810-B
(Ref. Drawing)

Order by Part Number and Description. Reference Numbers are for your convenience only.

WATER COOLED HEAT EXCHANGER – WITHOUT AFTERCOOLER

B/M: 302EBU4003; 303EBU4003
308EAQ4013; 309EAQ4013

Ref. No.	Name of Part	Qty.	Part No.	Ref. No.	Name of Part	Qty.	Part No.
1	HEAT EXCHANGER (Fresh Water)	1	200EAU349	24	NIPPLE	1	63M3G
	HEAT EXCHANGER (Salt Water)	1	203EAU349	25	U-BOLT	1	15U75
2	BRACKET (FORMED)	1	300EAQ142	26	NUT-FLANGED	2	50AW35
3	SUPPORT	1	300EAQ165	27	MANIFOLD-WATER	2	200EDM072
4	SCREW-FLANGED	18	75LM51	28	CONNECTOR-TUBE	8	86H141
5	NUT	18	50AW5	29	TUBE WITH FITTINGS	1	323EAU863
6	NIPPLE	1	63AJ48X50G	30	TUBE WITH FITTINGS	1	322EAU863
7	BRACKET-PIPE	1	200EAQ108	31	NIPPLE	1	63L24G
8	NUT-FLANGED	4	50AW5	32	TEE	1	64G1G
* 9	COUPLING-FLEXIBLE	1	64EB803	+ 33	PLUG	1	64B7
10	U-BOLT	2	15U108	34	TUBE WITH FITTINGS	1	325EAU863
11	U-BOLT	2	15U87	35	TUBE WITH FITTINGS	1	326EAU863
12	NUT-FLANGED	4	50AW35	36	TUBE WITH FITTINGS	1	310EAQ863
13	BRACKET-PIPE	2	200EDM108	37	SCREW	2	75LM51
14	NIPPLE	1	63AJ48X690G	38	BUSHING-PIPE	4	64EB304
15	VALVE-MINIMUM PRESSURE	1	201EDM527	∇ 39	FILTER – OIL	1	300EAQ369
16	NIPPLE	1	63P5G	40	NIPPLE	1	63K20G
17	ELBOW	3	64C10G	*** 41	STRAINER	1	82E49
18	NIPPLE	1	63P25G	42	PLUG	1	64AA3
19	UNION	1	64Z21	43	CONNECTOR	4	86H142
20	NIPPLE	1	63P20G	50	TUBE ASSEMBLY	1	See Page 22
21	BUSHING-PIPE	2	64E33	51	FILTER ASSEMBLY (150°) See Page 23	1	303EAQ2045
22	NIPPLE	1	63M2G		FILTER ASSEMBLY (180°) See Page 23	1	304EAQ2045
** 23	SEPARATOR-MOISTURE	1	83C92	53	BUSHING-PIPE	1	64E61
				54	OIL SAMPLING VALVE	1	86N345

* For Repair Order (2) 2117161 Gaskets.

** Repair Parts Kits for Moisture Separator: 2117587 – Valve & Seat Assembly; 2117588 – Cover Gasket; 2117589 – Float & Spindle.

*** Repair Parts for Strainer (100 Mesh Screen): 2118378; Blow-Off Bushing: 2118381.

+ NOTE: Remove this plug when Optional Water Temperature Regulator is used. This is the temperature probe location.

∇ Repair Element 2118342.

Note: For Repair Part Numbers for Heat Exchangers and Aftercoolers, see page 30.

REPAIR PARTS FOR HEAT EXCHANGER AND AFTERCOOLER

HEAT EXCHANGERS

Name of Part	Qty	Part No.
200EAU349 (Fresh Water)		
GASKET-RETURN	1	2117105
GASKET-IN/OUT	1	2117104
BONNET-RETURN.....	1	2117103
BONNET-IN/OUT	1	2117102
203EAU349 (Salt Water)		
BONNET-IN/OUT	1	2117757
BONNET-RETURN.....	1	2117758
GASKET-IN/OUT	1	2117104
GASKET-RETURN	1	2117105

AFTERCOOLERS

Name of Part	Qty	Part No.
204EAU292 (Fresh Water)		
GASKET-RETURN	1	2117105
GASKET-IN/OUT	1	2117104
BONNET-RETURN.....	1	2117103
BONNET-IN/OUT	1	2117102
206EAU292 (Salt Water)		
BONNET-IN/OUT	1	2117757
BONNET-RETURN.....	1	2117758
GASKET-IN/OUT	1	2117104
GASKET-RETURN	1	2117105

Order by Part Number and Description. Reference Numbers are for your convenience only.

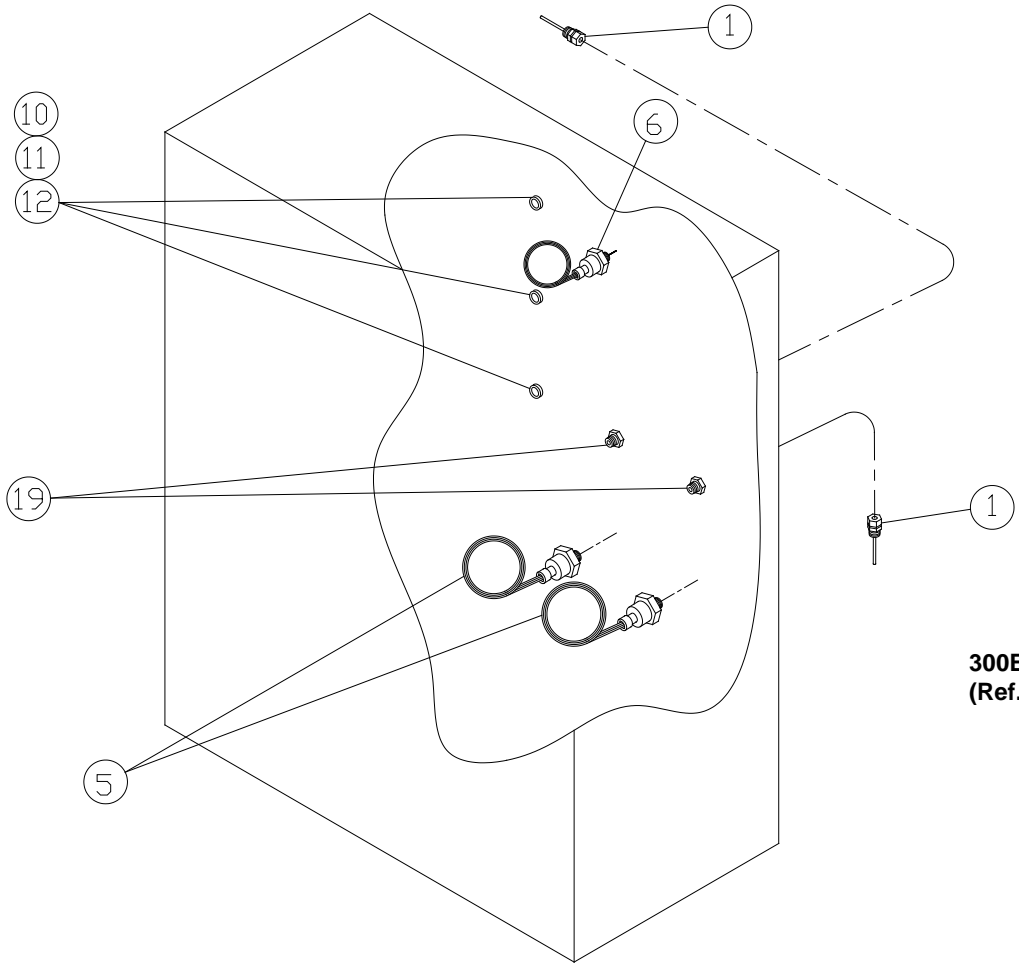

MISCELLANEOUS ELECTRICAL PARTS

B/M: 200ECP4007

Ref. No.	Name of Part	Qty.	Part No.
* 1	PROBE-ELECTRICAL.....	2	21D264
* 5	TRANSDUCER-PRESSURE.....	2	88H359
* 6	SWITCH-VACUUM.....	1	88H195
10	NIPPLE	3	24CA4641
11	O-RING.....	3	24A383
12	LOCKNUT-CONDUIT	3	24A77
19	FITTING-ELECTRICAL	2	24CA2865

* Parts included in Electrical Control Kit Part Number 306EAQ6013. Refer to page 58.

CONTROL SCHEMATIC

306EUB810-B
(Ref. Drawing)

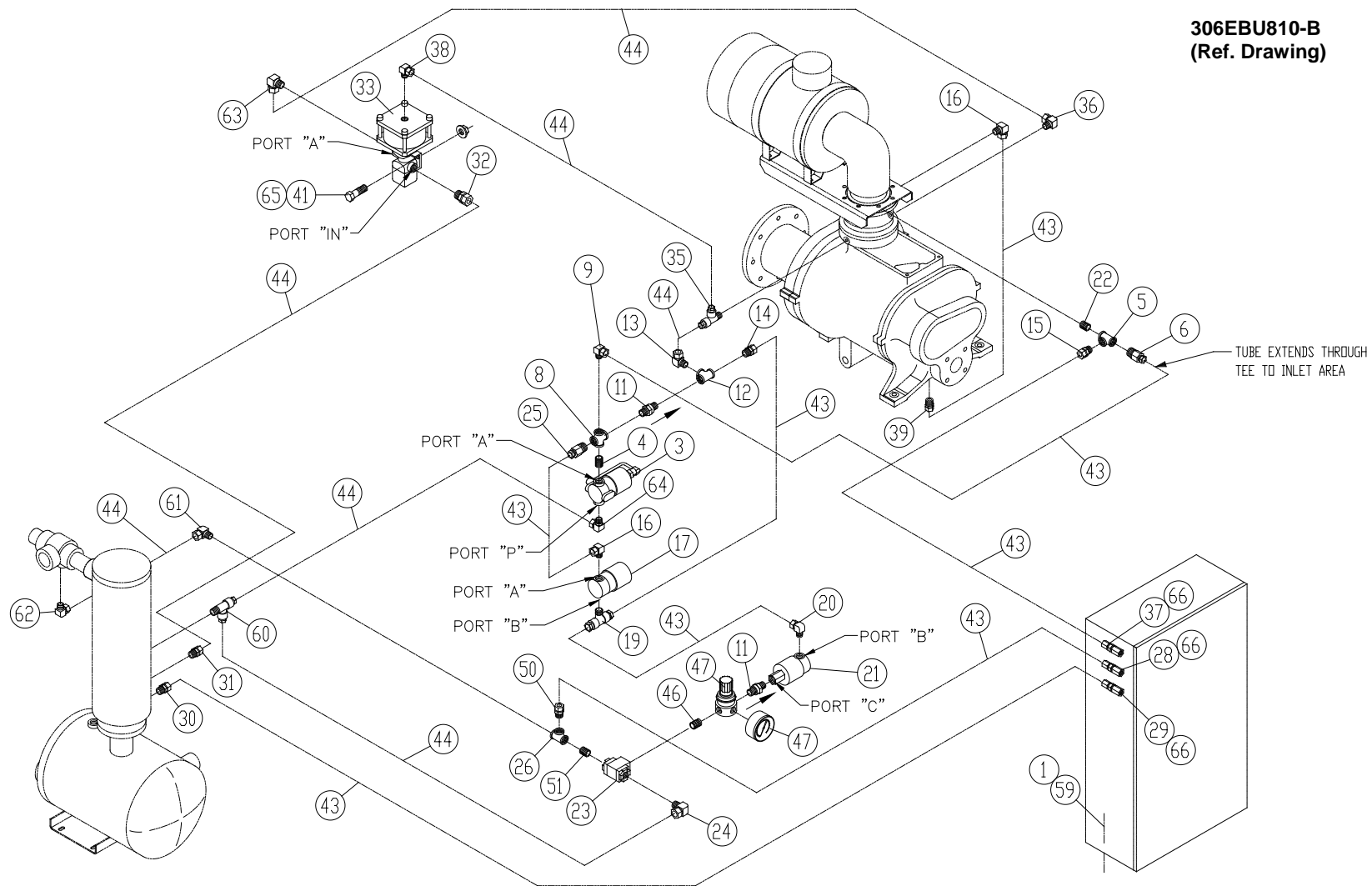

Order by Part Number and Description. Reference Numbers are for your convenience only.

CONTROL SCHEMATIC

B/M:
300EBU4002
300EBQ4052
301EBQ4052
Part No.

Ref. No.	Name of Part	Qty.	Part No.	Ref. No.	Name of Part	Qty.	Part No.
1	SCREW.....	4	75LM51	30	TUBE FITTING.....	1	86E210
*+ 3	VALVE-SOLENOID.....	1	91B70	31	TUBE FITTING.....	1	86E212
4	NIPPLE	1	63D1G	32	TUBE FITTING.....	1	86E212
5	TEE	1	64G3G	**++33	CONTROL VALVE	1	90AR1082
6	TUBE FITTING	1	86E242	35	TUBE FITTING.....	1	86E237
8	CROSS	1	64K1G	36	TUBE FITTING.....	1	86E222
9	TUBE FITTING	1	86E220	37	CONNECTOR-TUBE	1	86N287
++11	VALVE-CHECK.....	2	90AR261	38	TUBE FITTING.....	1	86E222
12	TEE	1	64G3G	39	TUBE FITTING.....	1	86E210
13	TUBE FITTING	1	86E222	41	NUT	2	50AW3
14	ORIFICE	1	86N289	43	TUBE (IN FEET)	28	85K3
15	TUBE FITTING	1	86E210	44	TUBE (IN FEET)	24	85K5
16	TUBE FITTING	2	86E220	46	NIPPLE	1	63D1G
+ 17	VALVE-SOLENOID.....	1	91B144	++▽47	REGULATOR-PRESS w/ GAUGE.....	1	88H367
19	TUBE FITTING	1	86E239	50	TUBE FITTING.....	1	86E210
20	TUBE FITTING	1	86E220	51	NIPPLE	1	63D1G
+ 21	VALVE-SOLENOID.....	1	91B143	59	NUT	4	50AW5
22	NIPPLE	1	63D1G	60	TEE	1	86E136
++23	VALVE-CONTROL.....	1	90AR1034	61	TUBE FITTING.....	1	86E237
24	TUBE FITTING	1	86E222	62	TUBE FITTING.....	1	86E222
25	TUBE FITTING	1	86E210	63	TUBE FITTING.....	1	86E222
26	TEE	1	64G3G	64	TUBE FITTING.....	1	86E222
28	CONNECTOR-TUBE	1	86N287	65	SCREW	2	75LM48
29	CONNECTOR-TUBE	1	86N287	66	O-RING	3	165011

* For Repair Kit (includes Springs, Seals, Piston Assembly, Plunger Assembly, Nut & O-Ring, order Part Number 2116077 or for Coil, order Part Number 2116078.

** For Repair of U-Cup (Piston Seal), order Part Number 2117904; For O-Ring (Top Plate), order Part Number 2117905.

+ Parts included in Electrical Control Kit, Part Number 306EAQ6013. Refer to page 58.

++ Parts included in Pneumatic Control Kit, Part Number 302EAQ6013. Refer to page 58.

▽ For Replacement Gauge, order Part Number 2118767.

Order by Part Number and Description. Reference Numbers are for your convenience only.

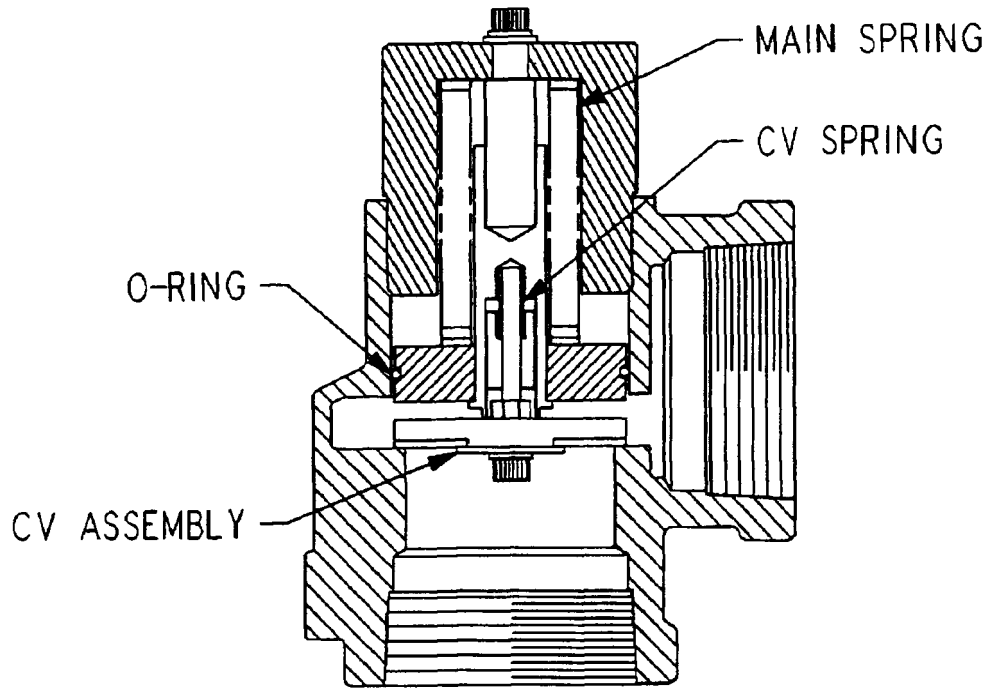

MINIMUM PRESSURE/CHECK VALVE

Name of Part	Qty.	Part No.
MINIMUM PRESSURE VALVE ASSEMBLY.....	1	201EDM527
REPAIR KIT:	1	2116855
CHECK VALVE ASSEMBLY.....	1	
MAIN SPRING.....	1	
CHECK VALVE SPRING	1	
O-RING	1	

Order by Part Number and Description. Reference Numbers are for your convenience only.

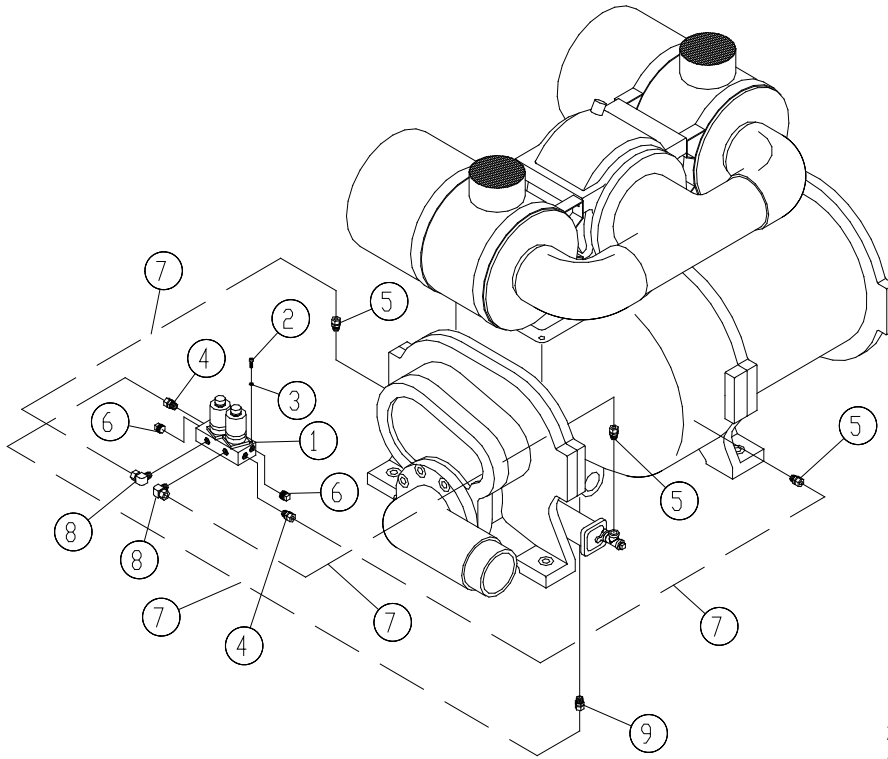

255EAU810-B
(Ref. Drawing)

TURN VALVE ACTUATOR – (EAU ONLY)

B/M: 203EAU4013

Ref. No.	Name of Part	Qty.	Part No.
1 *	VALVE-SOLENOID	1	301EAQ861
2	SCREW	2	75P26
3	LOCKWASHER.....	2	95B1
4	TUBE FITTING.....	2	86E211
5	TUBE FITTING.....	3	86E210
6	PLUG.....	2	64AC3
7	TUBE-BULK (IN FEET).....	20	85K3
8	TUBE FITTING.....	2	86E220
9	TUBE FITTING.....	1	86E211

*For O-Ring Repair Kit, order Part Number 307EAQ6013. Refer to Page 58.

Order by Part Number and Description. Reference Numbers are for your convenience only.

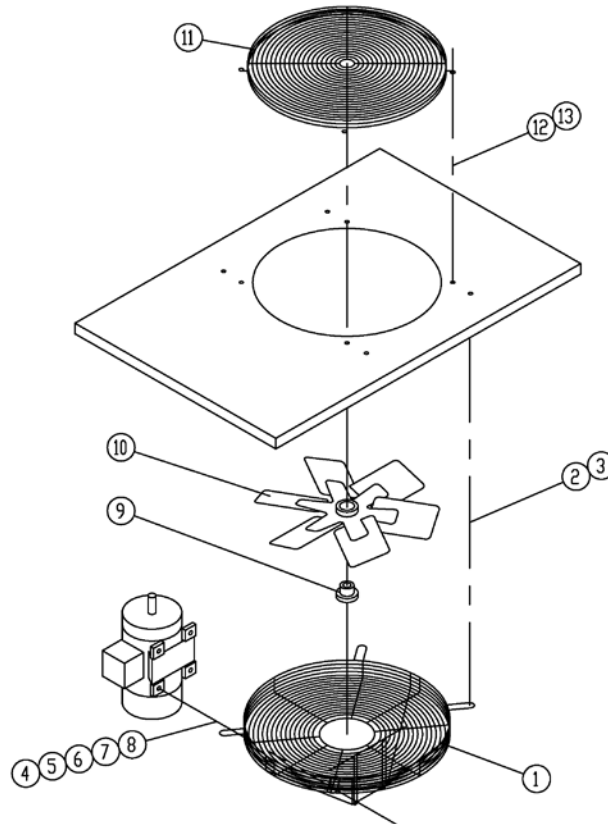

262EAU810-A
(Ref. Drawing)

**ENCLOSURE VENT FAN ASSEMBLY
(WATER COOLED ONLY)**

B/M: 300EBQ4017

Ref. No.	Name of Part	Qty.	Part No.
1	GUARD-FAN	1	202ECM393
2	SCREW	4	75K48
3	WASHER.....	4	95A5
4	SCREW	4	75A35
5	RETAINER.....	4	2014731
6	WASHER.....	4	95A2
7	LOCKWASHER	4	95B2
8	NUT	4	50B2
9	BUSHING-SHEAVE	1	22G27
10	FAN.....	1	202ECM701
11	GUARD-FAN	1	200ECM393
12	SCREW	4	75LM51
13	NUT	4	50AW5

For Motor Part Number refer to Page 47.

Order by Part Number and Description. Reference Numbers are for your convenience only.

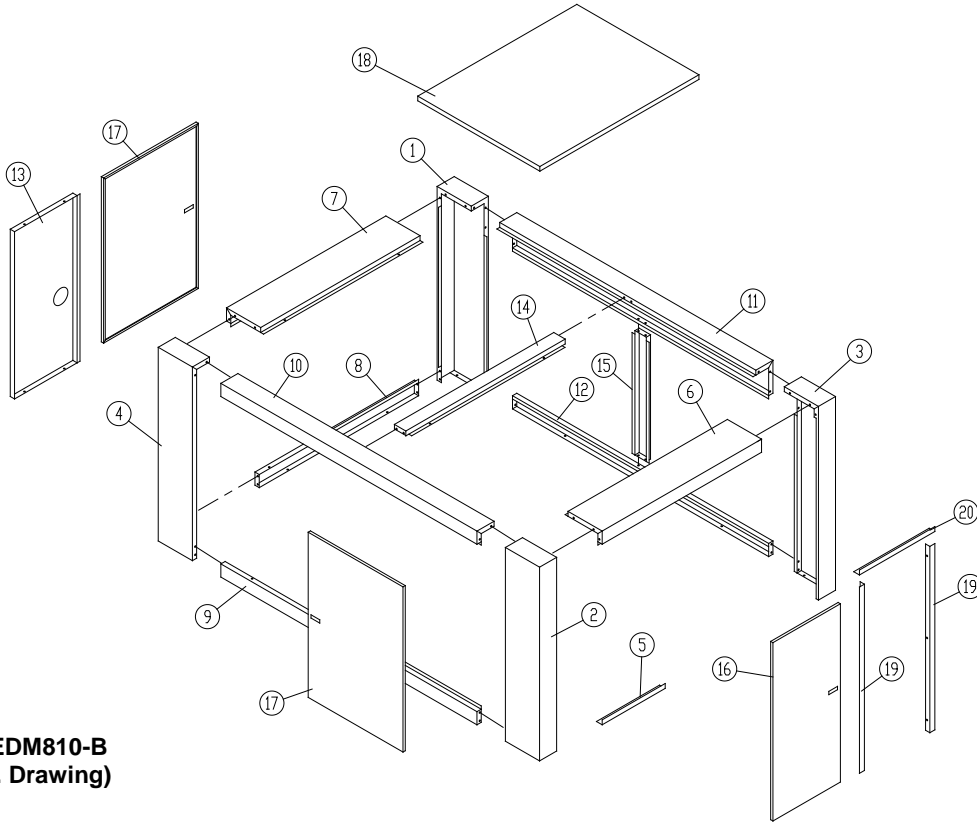

200EDM810-B
(Ref. Drawing)

**ENCLOSURE
(STANDARD)**

Ref. No.	Name of Part	Qty.	B/M: 300EBQ4023	B/M: 317EBU4023
			ODP Part No.	TEFC Part No.
1	POST.....	1	CC1046854	CC1046971
2	POST.....	1	CC1046856	CC1046856
3	POST.....	1	CC1046857	CC1046857
4	POST.....	1	CC1046858	CC1046972
5	FRAME.....	1	200EDM314	200EDM314
6	FRAME.....	1	201EDM314	201EDM314
7	FRAME.....	1	202EDM314	CC1046973
8	FRAME.....	1	203EDM314	CC1046974
9	FRAME.....	1	204EDM314	204EDM314
10	FRAME.....	1	205EDM314	205EDM314
11	FRAME.....	1	206EDM314	206EDM314
12	FRAME.....	1	207EDM314	207EDM314
13	BRACE.....	1	CC1046862	CC1046862
14	BRACE.....	1	201EDM326	201EDM326
15	BRACE.....	1	202EDM326	202EDM326
16	DOOR – CANOPY.....	1	CC1046859	CC1046859
17	DOOR – CANOPY.....	2	CC1046860	CC1046860
18	PANEL.....	1	203EDM216	203EDM216
19	BRACKET.....	2	201EDM142	201EDM142
20	BRACKET.....	1	202EDM142	202EDM142

Order by Part Number and Description. Reference Numbers are for your convenience only.

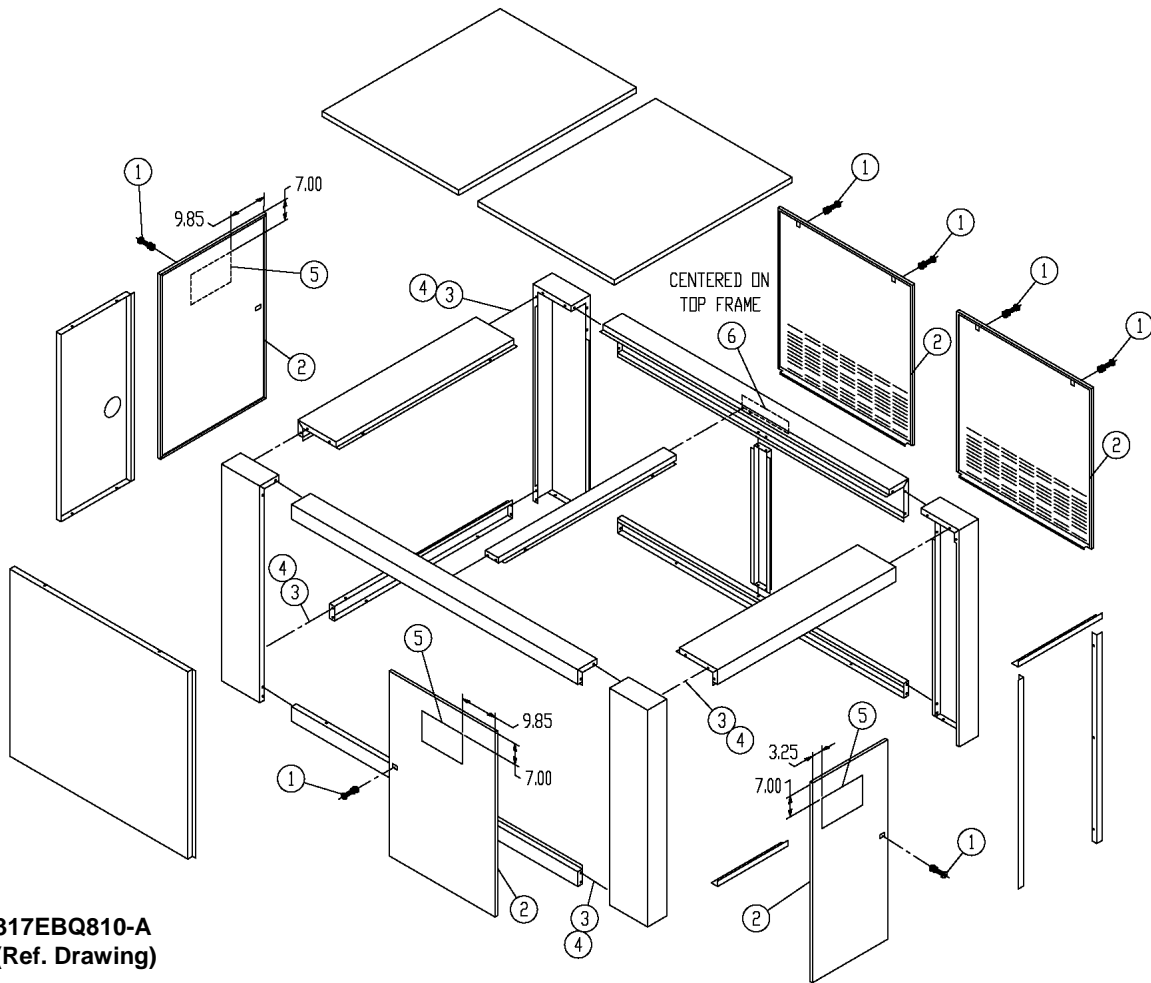

317EBQ810-A
(Ref. Drawing)

**ENCLOSURE – HARDWARE
(STANDARD & QUIET)**

**B/M: 307EBQ4017
ODP & TEFC**

Ref. No.	Name of Part	Qty.	Part No.
1	LATCH.....	7	31D68
2	SEAL (IN FEET).....	75	32E12
3	SCREW.....	90	75LM51
4	NUT.....	82	50AW5
5	DECAL.....	3	VP1042952
6	DECAL-"GARDNER DENVER".....	1	VP1044830
7	KEY (not shown).....	2	VP1049035

Order by Part Number and Description. Reference Numbers are for your convenience only.

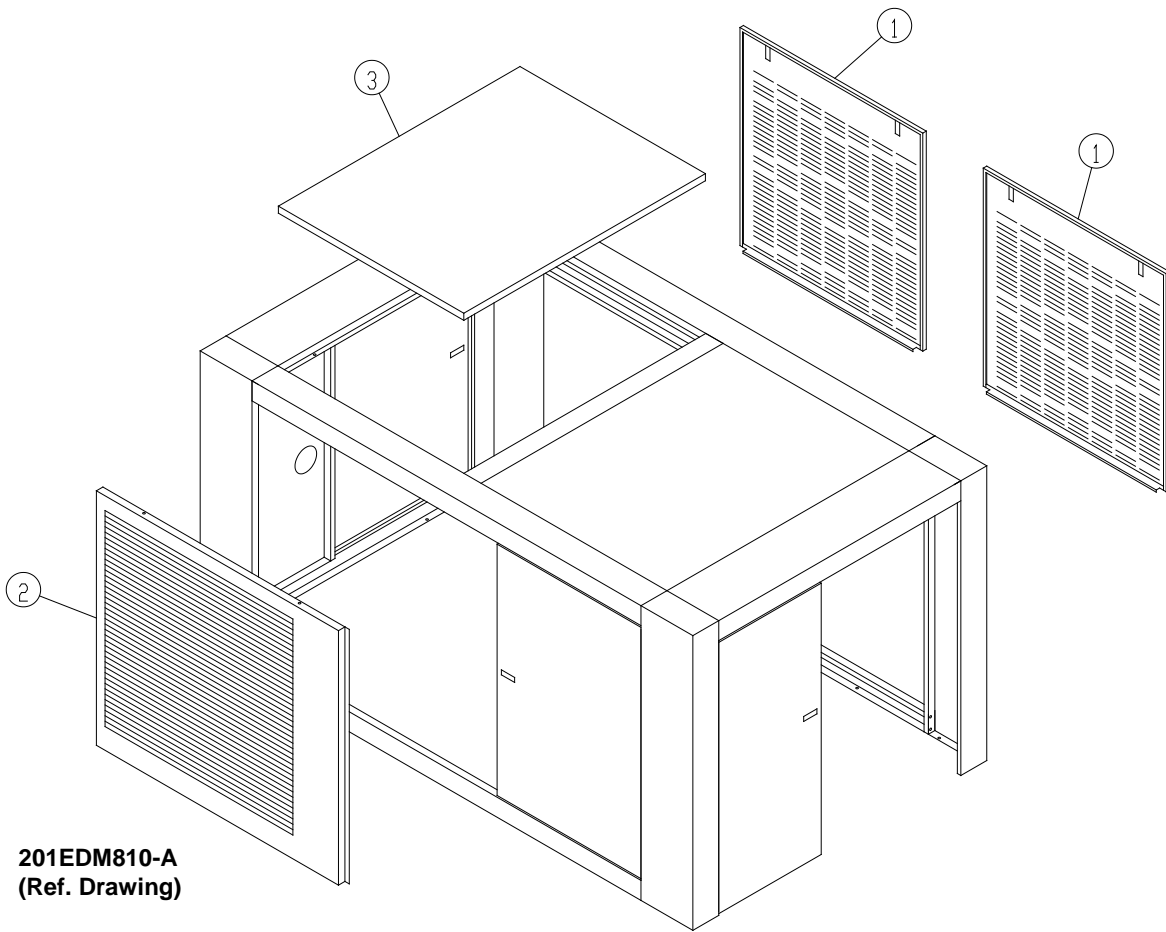

**ENCLOSURE – AIR COOLED PANELS
(STANDARD)**

**B/M: 201EDM4023
ODP & TEFC**

Ref. No.	Name of Part	Qty.	Part No.
1	PANEL.....	2	CC1018159
2	PANEL.....	1	202EDM216
3	PANEL.....	1	203EDM216

Order by Part Number and Description. Reference Numbers are for your convenience only.

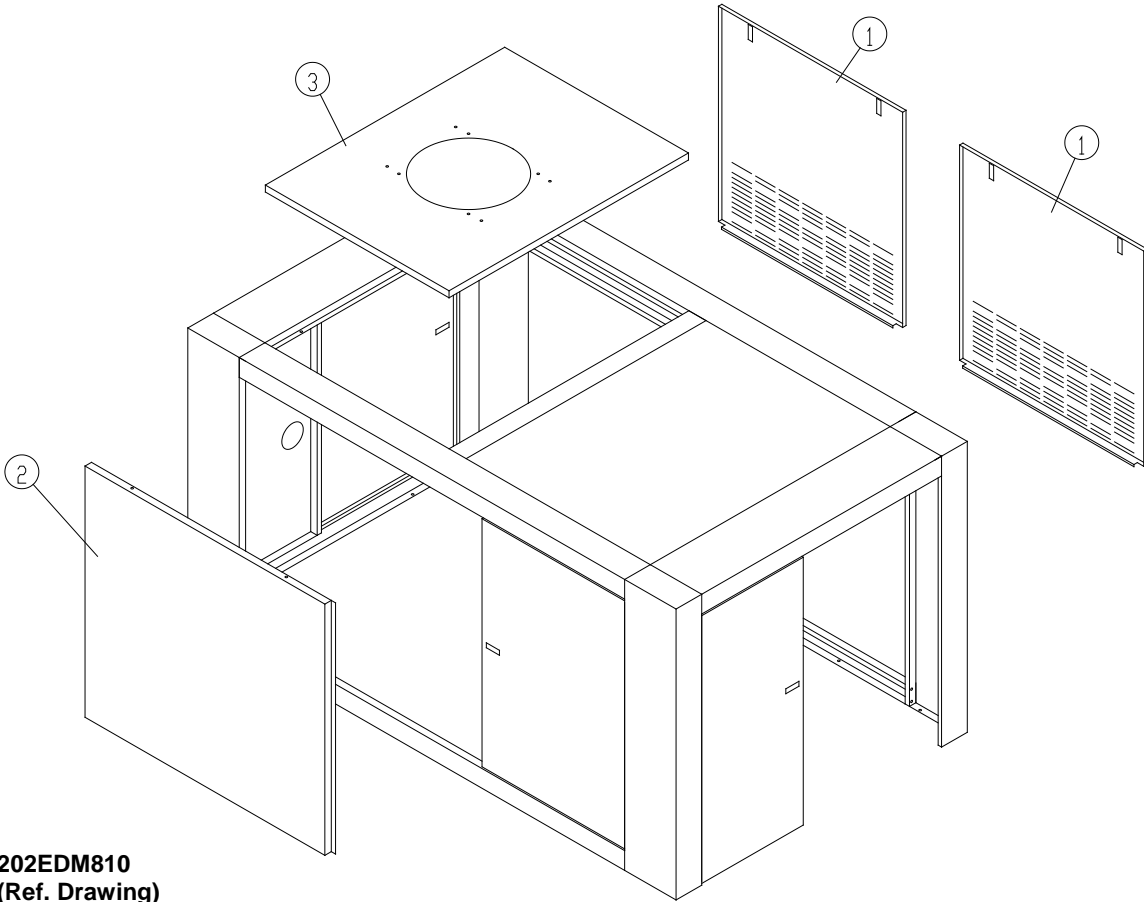

202EDM810
(Ref. Drawing)

**ENCLOSURE – WATER COOLED PANELS
(STANDARD)**

**B/M: 202EDM4023
ODP & TEFC**

Ref. No.	Name of Part	Qty.	Part No.
1	PANEL.....	2	CC1018160
2	PANEL.....	1	204EDM216
3	PANEL.....	1	205EDM216

Order by Part Number and Description. Reference Numbers are for your convenience only.

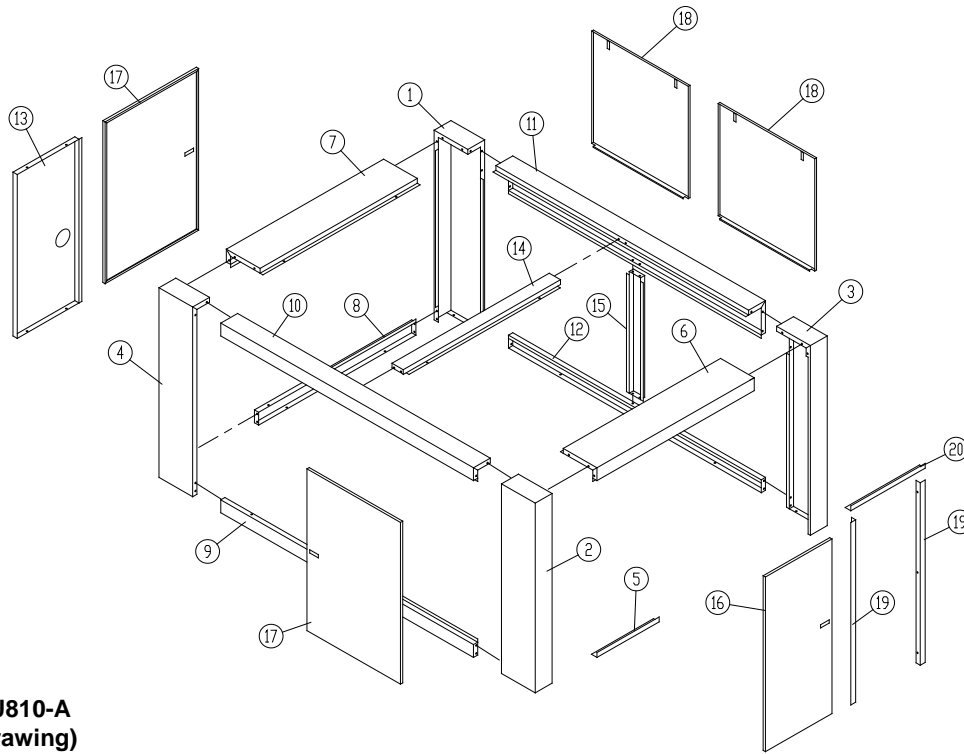

305EBU810-A
(Ref. Drawing)

**ENCLOSURE – BASIC
(QUIET)**

Ref. No.	Name of Part	Qty.	B/M: 301EBQ4023	B/M: 318EBU4023
			ODP Part No.	TEFC Part No.
1	POST	1	CC1046854	CC1046971
2	POST	1	CC1046856	CC1046856
3	POST	1	CC1046857	CC1046857
4	POST	1	CC1046858	CC1046972
5	FRAME	1	200EDM314	200EDM314
6	FRAME	1	201EDM314	201EDM314
7	FRAME	1	202EDM314	CC1046973
8	FRAME	1	203EDM314	CC1046974
9	FRAME	1	204EDM314	204EDM314
10	FRAME	1	205EDM314	205EDM314
11	FRAME	1	206EDM314	206EDM314
12	FRAME	1	207EDM314	207EDM314
13	BRACE (MOTOR SIDE)	1	CC1046864	CC1046864
14	BRACE	1	201EDM326	201EDM326
15	BRACE	1	202EDM326	202EDM326
16	DOOR (CONTROL SIDE)	1	CC1046866	CC1046866
17	DOOR	2	CC1046865	CC1046865
18	PANEL (QUIET)	2	CC1018163	CC1018163
19	BRACKET	2	201EDM142	201EDM142
20	BRACKET	1	202EDM142	202EDM142

Order by Part Number and Description. Reference Numbers are for your convenience only.

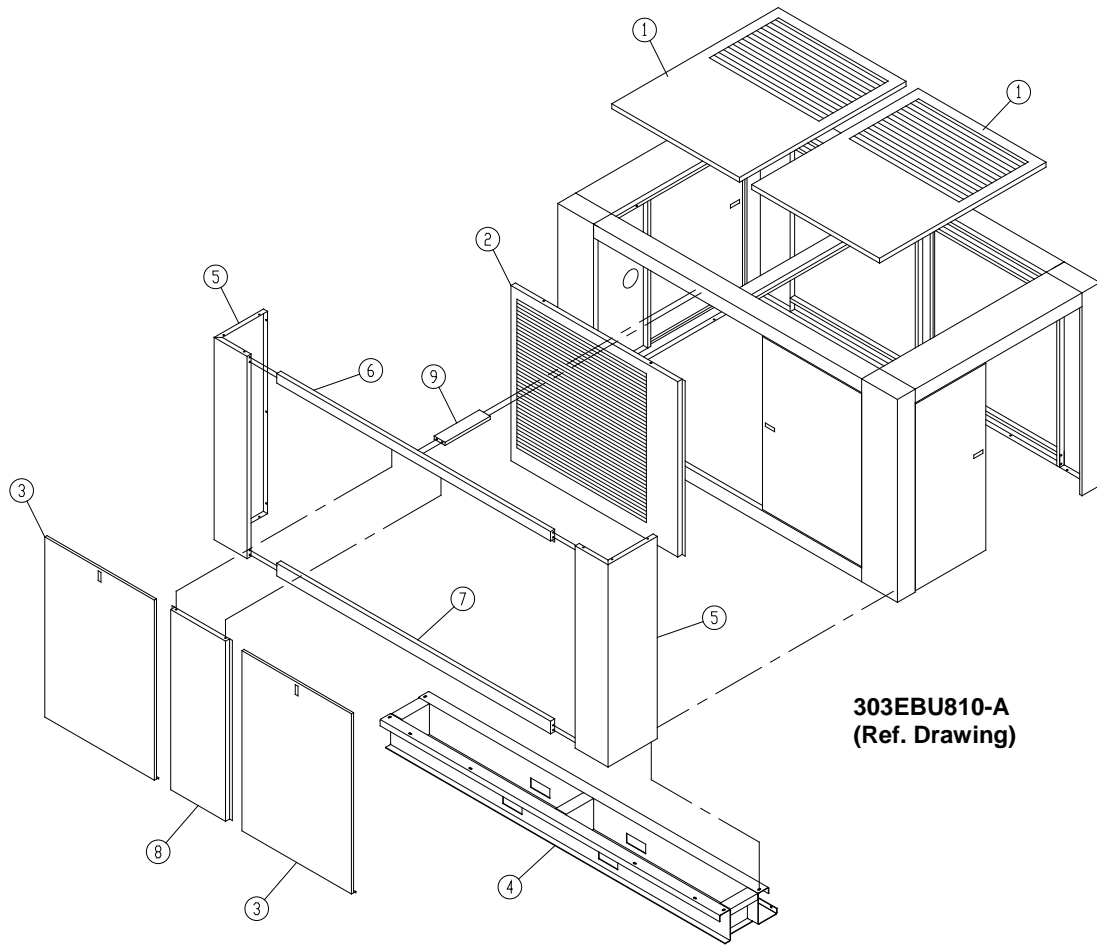

303EBU810-A
(Ref. Drawing)

**AIR COOLED BAFFLE
(QUIET)**

**B/M: 302EBQ4023
ODP & TEFC**

Ref. No.	Name of Part	Qty.	Part No.
1	PANEL (TOP AIR INLET)	2	300EBU216
2	PANEL	1	202EDM216
3	PANEL	2	CC1018164
4	BASE	1	300EBU285
5	POST	2	CC1046863
6	FRAME	1	300EBU314
7	FRAME (BAFFLE BOTTOM).....	1	301EBU314
8	BRACE (BAFFLE SIDE).....	1	301EBU326
9	BRACE.....	1	205EAU326

Order by Part Number and Description. Reference Numbers are for your convenience only.

318EBQ810-A
(Ref. Drawing)

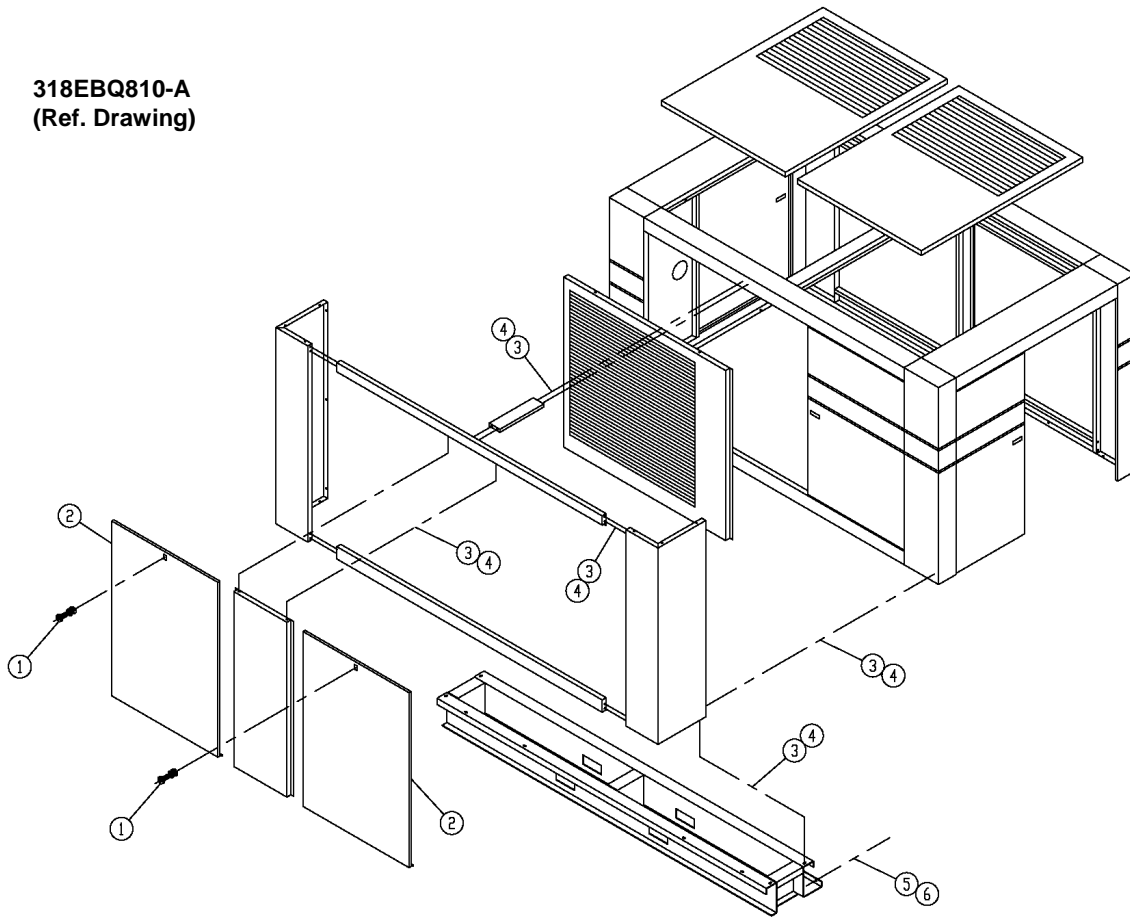

**AIR COOLED BAFFLE HARDWARE
(QUIET)**

**B/M: 308EBQ4017
ODP & TEFC**

Ref. No.	Name of Part	Qty.	Part No.
1	LATCH.....	2	31D68
2	SEAL (IN FEET)	25	32E12
3	SCREW	30	75LM51
4	NUT	30	50AW5
5	SCREW	4	75LM135
6	NUT	4	50AW35

Order by Part Number and Description. Reference Numbers are for your convenience only.

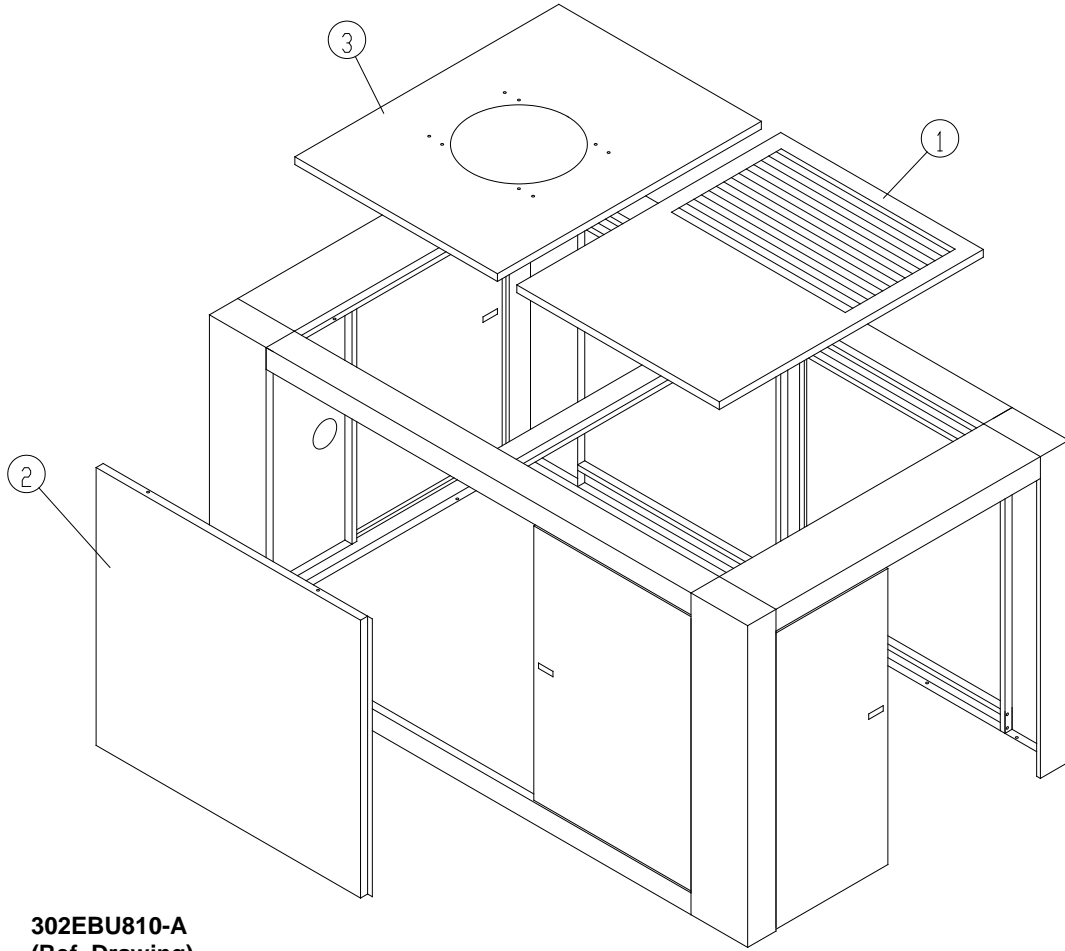

302EBU810-A
(Ref. Drawing)

**ENCLOSURE – WATER COOLED
(QUIET)**

**B/M: 300EBU4023
ODP & TEFC**

Ref. No.	Name of Part	Qty.	Part No.
1	PANEL (TOP AIR INLET).....	1	300EBU216
2	PANEL.....	1	302EBU216
3	PANEL.....	1	301EBU216

Order by Part Number and Description. Reference Numbers are for your convenience only.

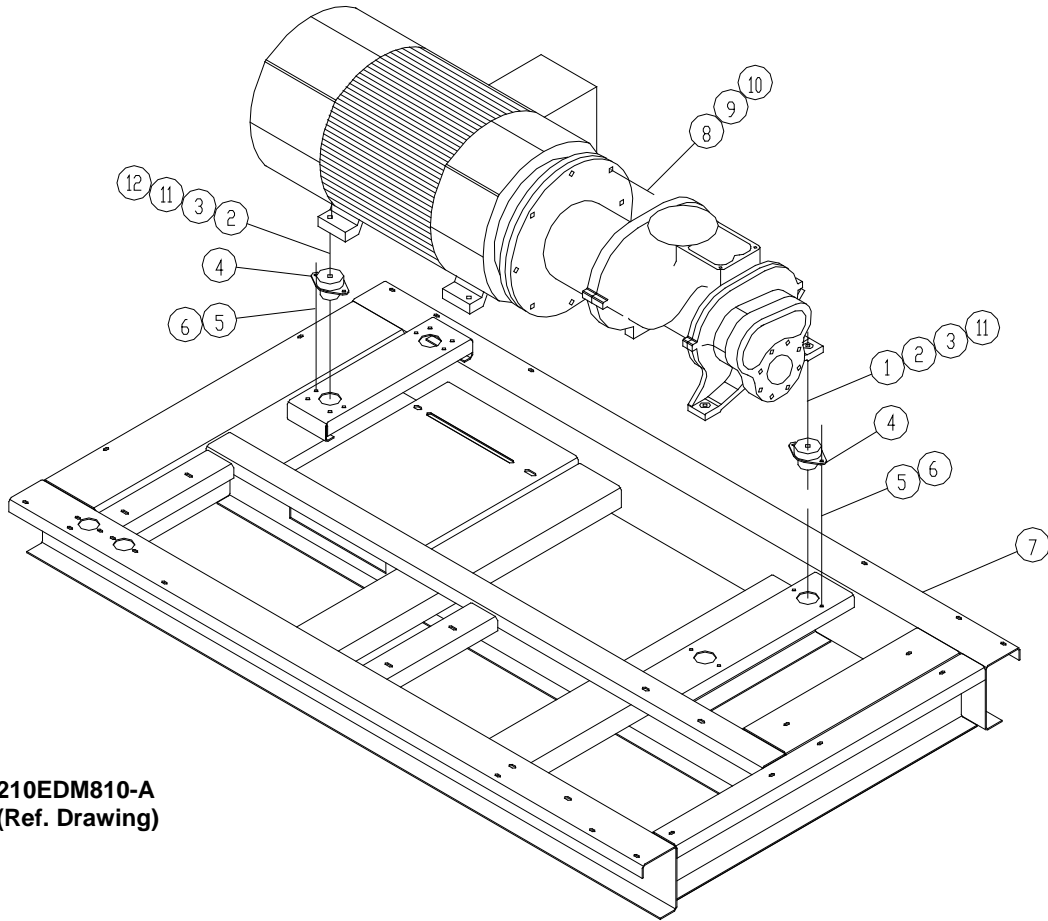

210EDM810-A
(Ref. Drawing)

COMPRESSOR BASE GROUP

B/M: 311EAQ4017

Ref. No.	Name of Part	Qty.	Part No.
1	SCREW	2	655EG220
2	LOCKWASHER	4	95B8
3	NUT	4	50B8
4	ISOLATOR-VIBRATION.....	4	49C48
5	SCREW	8	75LM135
6	NUT	8	50AW35
7	BASE	1	300EAQ285
8	NUT	8	50B8
9	LOCKWASHER	8	95B8
10	SCREW	8	655EG140
11	WASHER.....	4	95A8
12	SCREW	2	655EG240

Order by Part Number and Description. Reference Numbers are for your convenience only.

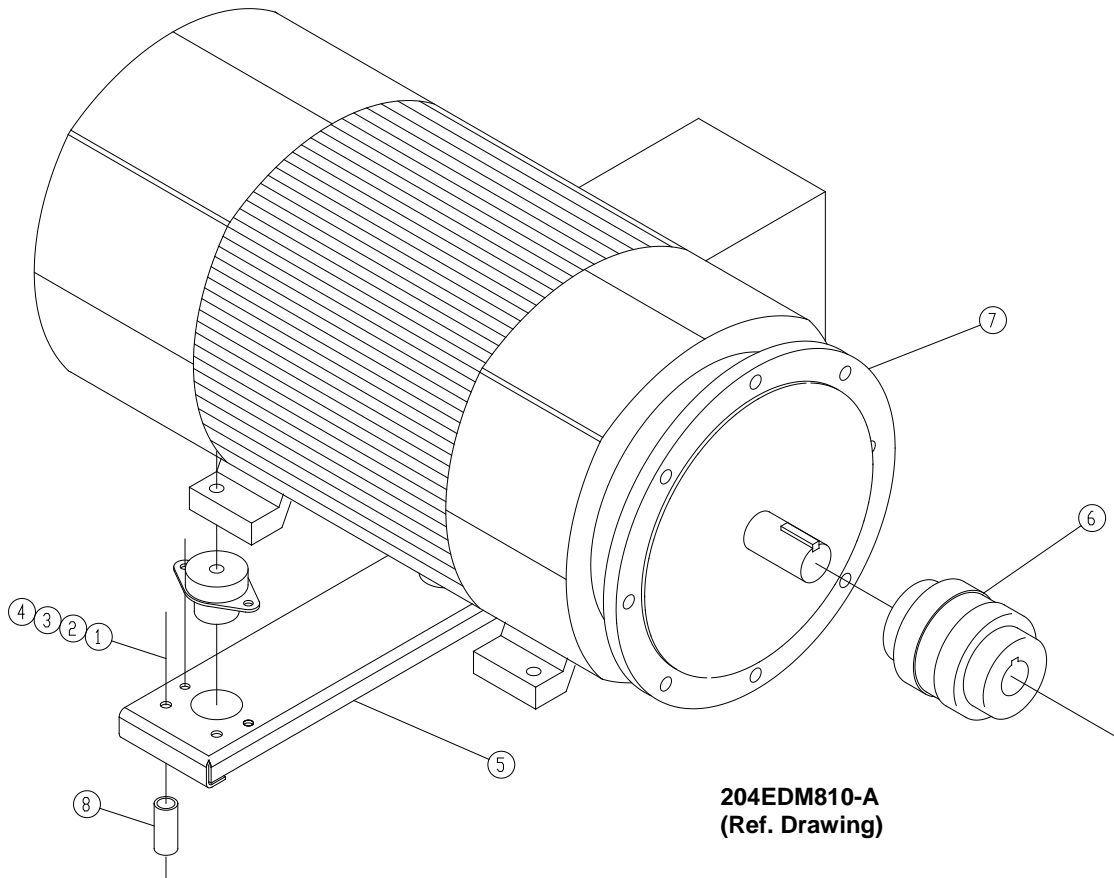

MAIN MOTOR GROUP

Ref. No.	Name of Part	Qty.	Part No.
1	WASHER	4	95A7
2	LOCKWASHER	4	95B7
3	NUT.....	4	50B7
4	SCREW.....	4	655EF160
5	SUPPORT-MOTOR.....	1	200EDM620
*6	DRIVE COUPLING-FLEXIBLE	1	51L221
7	MOTOR.....	1	See page 47
8	NIPPLE	4	63AM12X22G

* NOTE: Drive Coupling repair Spider Part No. 2118273.

**MOTOR GROUP (MAIN DRIVE MOTORS)
200 HP**

Name of Part	FULL VOLTAGE Part No.	WYE DELTA Part No.
---------------------	--------------------------------------	-------------------------------

OPEN DRIP PROOF -- 60 HZ – ODP - EISA EFFICIENCY

MOTOR, 230V	24CA6423	24CA6429
MOTOR, 460V	24CA6430	24CA6430
MOTOR, 575V	24CA6425	24CA6431

TOTALLY ENCLOSED FAN COOLED (TEFC) – 60 HZ – EISA EFFICIENCY

MOTOR, 230V	24CA6426	24CA6432
MOTOR, 460V	24CA6433	24CA6433
MOTOR, 575V	24CA6428	24CA6434

**MOTOR GROUP
AIR COOLED FAN MOTOR (COOLING MODULE)
(TEFC, 5 HP, 1.33 S.F., 1200 RPM, 60 HZ)**

VOLTAGE	PART NO.
MOTOR, 230V	24CA6587
MOTOR, 460V	24CA6587
MOTOR, 575V	24CA6588

**WATER COOLED FAN MOTOR (ENCLOSURE) VENT FAN
(TEFC, 1200 RPM, 60 HZ, 1.0 S.F.)**

VOLTAGE	PART NO.	HP
MOTOR, 230V	24CA2464	1/4
MOTOR, 460V	24CA2464	1/4
MOTOR, 575V	24CA4178	1/2

OVERLOAD RELAY HEATER CONVERSION LISTING

Refer to Motor Nameplate “Amperage” and Decal in Control Panel for Selection of Overload Relay Heater Packs

CUTLER-HAMMER PART NUMBER	GARDNER DENVER PART NUMBER
H2002B	24CA4101
H2003B	24CA4102
H2004B	24CA4103
H2005B	24CA4104
H2006B	24CA4105
H2007B	24CA4106
H2008B	24CA4107
H2009B	24CA4108
H2010B	24CA4109
H2011B	24CA4110
H2012B	24CA4111
H2013B	24CA4112
H2014B	24CA4113
H2015B	24CA4114
H2016B	24CA4115
H2017B	24CA4116
H2018	24CA2924
H2019	24CA2925
H2020	24CA2926
H2021	24CA2927
H2022	24CA2893
H2023	24CA2894
H2024	24CA2928

Order by Part Number and Description. Reference Numbers are for your convenience only.

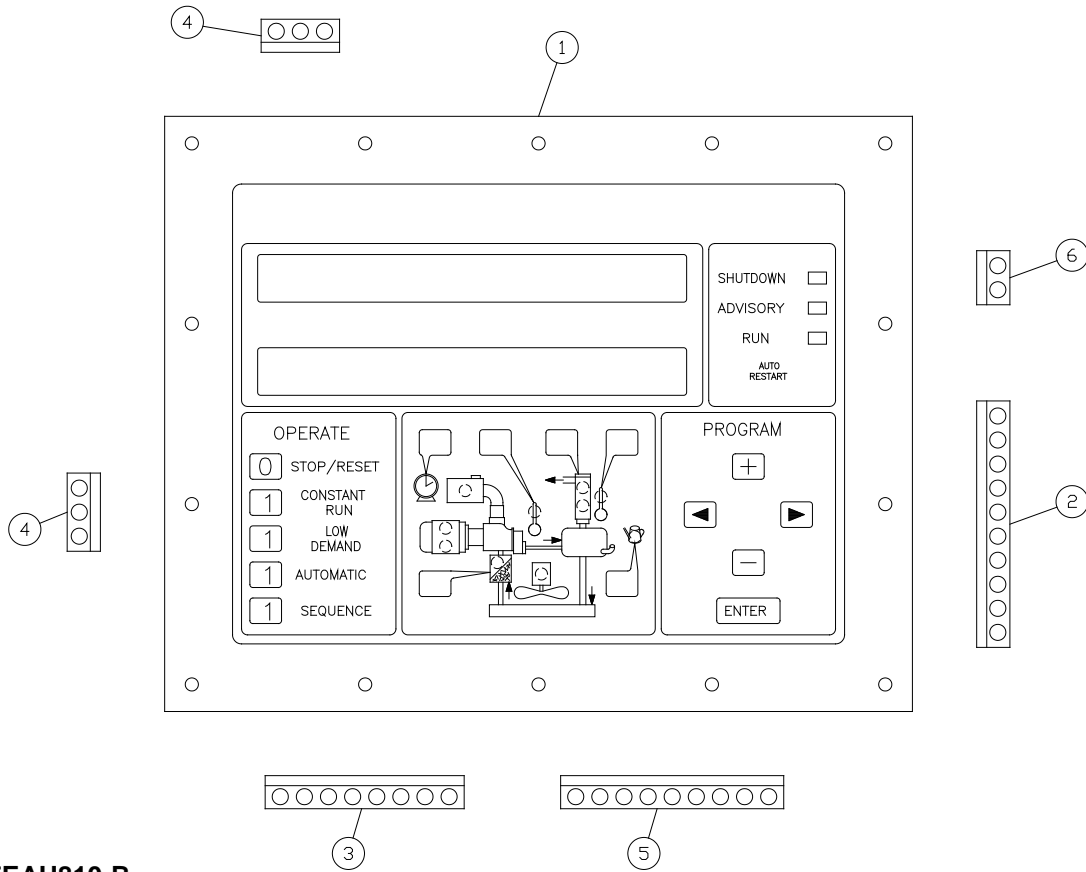

327EAU810-B
(Ref. Drawing)

CONTROLLER ASSEMBLY

B/M: 302EAU2006

Ref. No.	Name of Part	Qty.	Part No.
1	CONTROLLER, AUTO SENTRY ES+	1	302EAU1173
2	PLUG-CONNECTOR 10 PIN TERMINAL.....	1	24CA3306
3	PLUG-CONNECTOR 8 PIN TERMINAL.....	1	24CA3400
4	PLUG-CONNECTOR 3 PIN TERMINAL.....	2	24CA3401
5	PLUG-CONNECTOR 9 PIN TERMINAL.....	1	24CA3402
6	PLUG-CONNECTOR 2 PIN TERMINAL.....	1	24CA4240

**CONTROLLER ASSEMBLY – WYE DELTA STARTERS
(EAU & EBU – 200 HP [200/230 VOLT NOT AVAILABLE])**

**302EAQ797-A
(Ref. Drawing)**

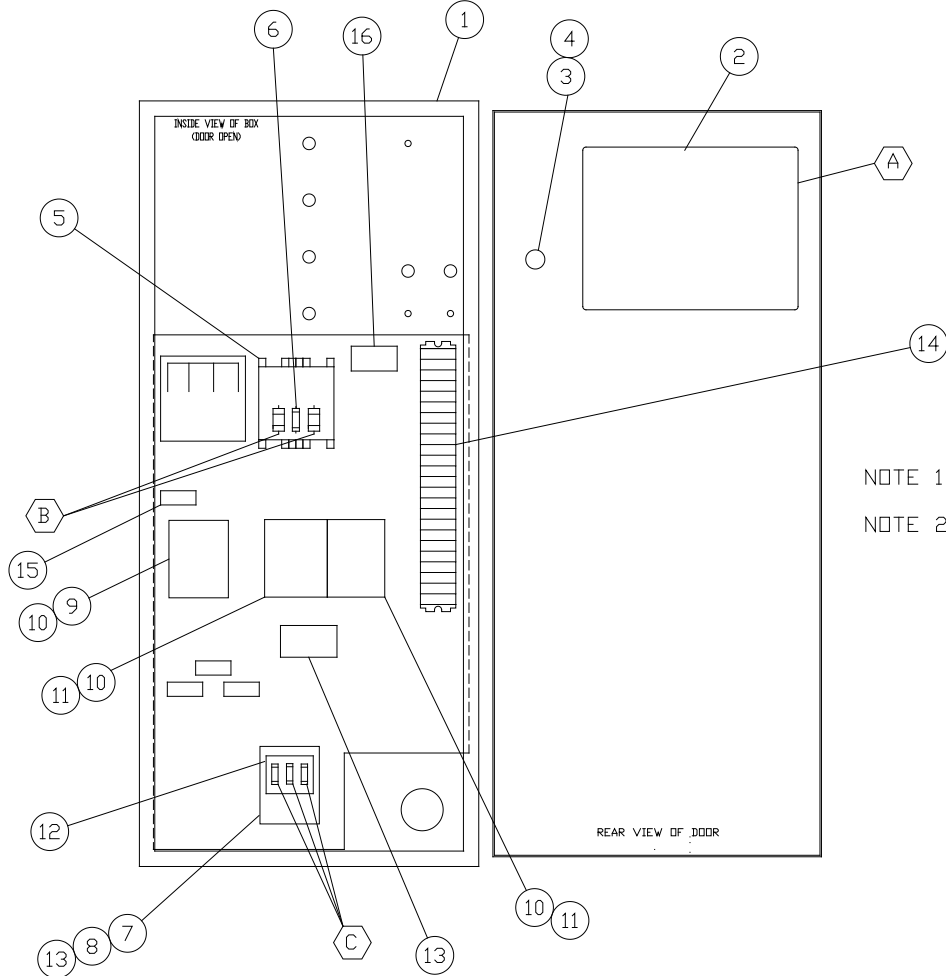

NOTE 1 - ITEMS 15 & 16 ARE USED ONLY ON PANELS WITH ES + AND CURRENT MONITORING.
NOTE 2 - ITEM 10 IS INCLUDED IN 9 & 11.
ITEM 8 & 13 ARE INCLUDED IN 7.

**CONTROLLER ASSEMBLY – WYE DELTA STARTERS
(EAU & EBU – 200 HP [200/230 VOLT NOT AVAILABLE])**

	Qty.	200 HP 460V	200 HP 575V
ASSEMBLED PANEL – ES+ : NEMA 12, With Current Monitor	1	227EAQ466	229EAQ466
ASSEMBLED PANEL – ES+ : NEMA 4, With Current Monitor	1	234EAQ466	236EAQ466
A FUSE, CONTROL BOARD (1A, AGC).....	1	24CA2932 (1A)	24CA2932 (1A)
B FUSE, TRANSFORMER PRIMARY (-A, FNQ-R)	2	24CA2783 (3A)	24CA3722 (2.25A)
C FUSE, FAN MOTOR, AIR COOLED (-A, LP-CC)	3	24CA4097 (25A)	24CA4096 (15A)
C FUSE, FAN MOTOR, WATER COOLED (-A, LP-CC)	3	24CA4092 (6A)	24CA4090 (3A)
* 1 ASSEMBLY CONTROL	1	302EAU2006	302EAU2006
2 BOX-CONTROL			
NEMA 12.....	1	200EDM179	200EDM179
NEMA 4	1	201EDM179	201EDM179
3 OPERATOR, EMERGENCY STOP	1	24CA2907	24CA2907
4 CONTACT BLOCK	1	24CA2908	24CA2908
5 TRANSFORMER	1	2118244	2118245
6 FUSE	1	24CA3729	24CA3729
7 STARTER	1	24CA4134	24CA4134
8 COIL STARTER.....	1	2115950	2115950
9 STARTER	1	24CA3490	24CA3255
10 COIL	3	2115952	2116555
11 CONTACTOR	2	24CA3696	24CA3259
12 FUSE HOLDER	1	24CA4098	24CA4098
13 RELAY	2	24CA4086	24CA4086
14 BLOCK.....	6	24CA2633	24CA2633
15 CURRENT TRANSFORMER.....	1	24CA4242	24CA4242
16 CURRENT TRANSDUCER.....	1	24CA4241	24CA4241

Refer page 49, for Controller Part Numbers.

**CONTROLLER ASSEMBLY – FULL VOLTAGE STARTERS
(EAU & EBU – 200 HP [200/230 VOLT NOT AVAILABLE])**

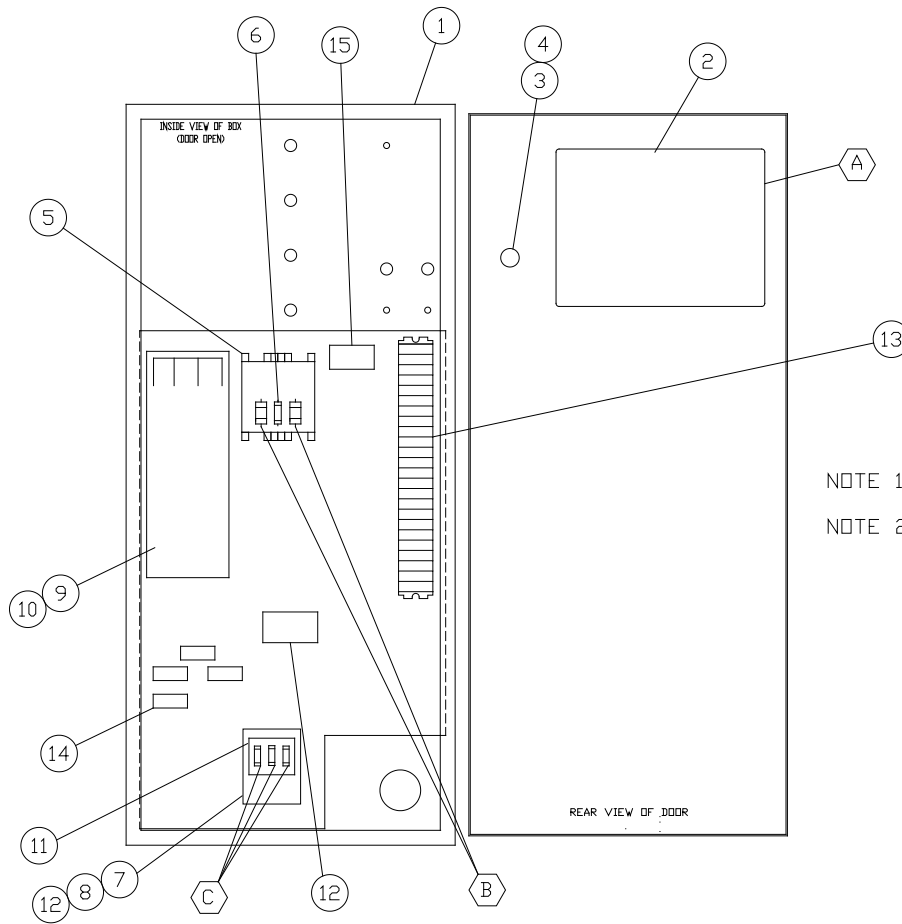

**301EAQ797-A
(Ref. Drawing)**

NOTE 1 - ITEMS 14 & 15 ARE USED ONLY ON PANELS WITH ES + AND CURRENT MONITORING.
NOTE 2 - ITEM 10 IS INCLUDED IN 9, ITEMS 8 & 12 ARE INCLUDED IN 7.

**CONTROLLER ASSEMBLY – FULL VOLTAGE STARTERS
(EAU & EBU – 200 HP [200/230 VOLT NOT AVAILABLE])**

	Qty.	200 HP 460V	200 HP 575V
ASSEMBLED PANEL – ES+ : NEMA 12, With Current Monitor	1	240EAQ466	241EAQ466
ASSEMBLED PANEL – ES+ : NEMA 4, With Current Monitor	1	242EAQ466	243EAQ466
A FUSE, CONTROL BOARD (1A, AGC).....	1	24CA2932 (1A)	24CA2932 (1A)
B FUSE, TRANSFORMER PRIMARY (-A, FNQ-R)	2	24CA2783 (3A)	24CA3722 (2.25A)
C FUSE, FAN MOTOR, AIR COOLED (-A, LP-CC)	3	24CA4096 (15A)	24CA4096 (15A)
C FUSE, FAN MOTOR, WATER COOLED (-A, LP-CC)	3	24CA4090 (3A)	24CA4090 (3A)
* 1 ASSEMBLY CONTROL	1	302EAU2006	302EAU2006
2 BOX-CONTROL			
NEMA 12.....	1	200EDM179	200EDM179
NEMA 4	1	201EDM179	201EDM179
3 OPERATOR, EMERGENCY STOP	1	24CA2907	24CA2907
4 CONTACT BLOCK	1	24CA2908	24CA2908
5 TRANSFORMER	1	2118244	2118245
6 FUSE	1	24CA3729	24CA3729
7 STARTER	1	24CA4134	24CA4134
8 COIL STARTER.....	1	2115950	2115950
9 STARTER	1	24CA3490	24CA3490
10 COIL	1	2115952	2115952
11 FUSE HOLDER	1	24CA4098	24CA4098
12 RELAY	2	24CA4086	24CA4086
13 BLOCK.....	6	24CA2633	24CA2633
14 CURRENT TRANSFORMER.....	1	24CA4242	24CA4242
15 CURRENT TRANSDUCER.....	1	24CA4241	24CA4241

Refer page 49, for Controller Part Numbers.

**CONTROLLER ASSEMBLY – LESS STARTER
(EAU & EBU)**

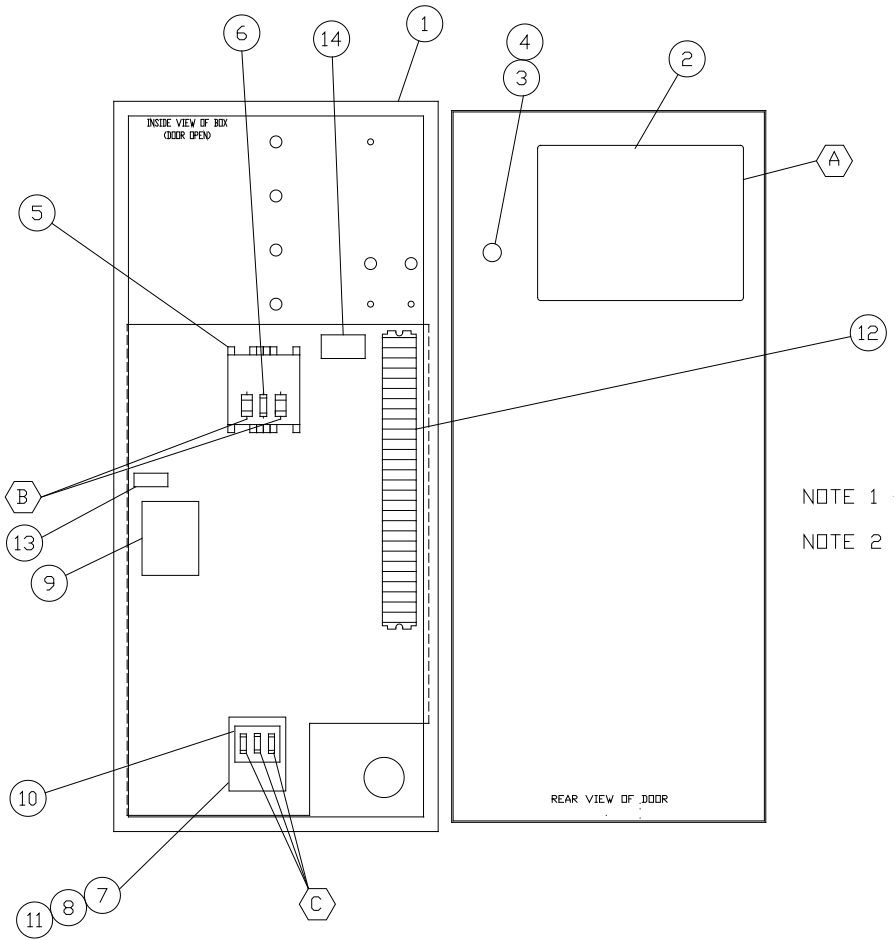

**303EAQ797-A
(Ref. Drawing)**

NOTE 1 - ITEMS 13 & 14 ARE USED ONLY ON PANELS WITH ES + AND CURRENT MONITORING.
NOTE 2 - ITEMS 8 & 11 ARE INCLUDED IN 7.

**CONTROLLER ASSEMBLY – LESS STARTER
(EAU & EBU)**

	Qty.	200 HP 230V	200 HP 460V	200 HP 575V
ASSEMBLED PANEL – ES+ : NEMA 12, With Current Monitor	1	244EAQ466	244EAQ466	246EAQ466
ASSEMBLED PANEL – ES+ : NEMA 4, With Current Monitor	1	248EAQ466	248EAQ466	250EAQ466
A FUSE, CONTROL BOARD (1A, AGC).....	1	24CA2932 (1A)	24CA2932 (1A)	24CA2932 (1A)
B FUSE, TRANSFORMER PRIMARY (-A, FNQ-R)	2	24CA2785 (5A)	24CA2783 (3A)	24CA3722 (2.25A)
C FUSE, FAN MOTOR, AIR COOLED (-A, LP-CC)	3	24CA4097 (25A)	24CA4096 (15A)	24CA4096 (15A)
C FUSE, FAN MOTOR, WATER COOLED (-A, LP-CC)	3	24CA4092 (6A)	24CA4092 (6A)	24CA4090 (3A)
* 1 ASSEMBLY CONTROL	1	302EAU2006	302EAU2006	302EAU2006
2 BOX-CONTROL				
NEMA 12.....	1	200EDM179	200EDM179	200EDM179
NEMA 4	1	201EDM179	201EDM179	201EDM179
3 OPERATOR, EMERGENCY STOP	1	24CA2907	24CA2907	24CA2907
4 CONTACT BLOCK	1	24CA2908	24CA2908	24CA2908
5 TRANSFORMER	1	2118244	2118244	2118245
6 FUSE	1	24CA3729	24CA3729	24CA3729
7 STARTER	1	24CA4134	24CA4134	24CA4134
8 COIL STARTER.....	1	2115950	2115950	2115950
9 CONTROL RELAY	1	24CA3896	24CA3896	24CA3896
10 FUSE HOLDER	1	24CA4098	24CA4098	24CA4098
11 RELAY	1	24CA4086	24CA4086	24CA4086
12 BLOCK.....	7	24CA2633	24CA2633	24CA2633
13 CURRENT TRANSFORMER.....	1	24CA4242	24CA4242	24CA4242
14 CURRENT TRANSDUCER.....	1	24CA4241	24CA4241	24CA4241

Refer page 49, for Controller Part Numbers.

IDENTIFICATION AND INSTRUCTION GROUP

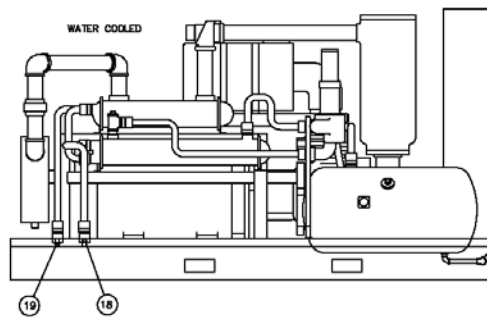
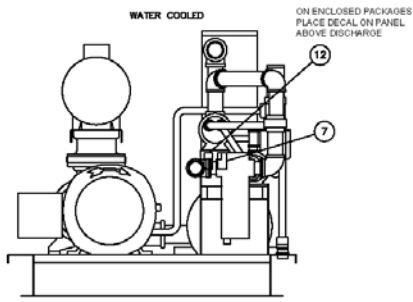
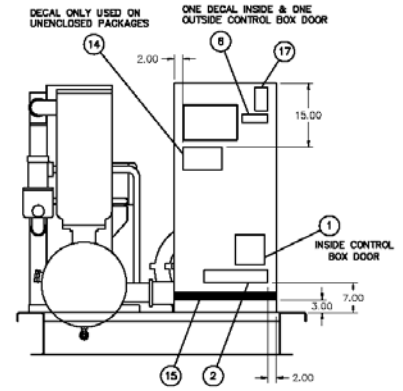
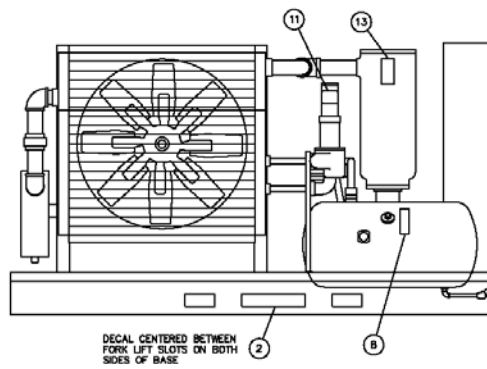
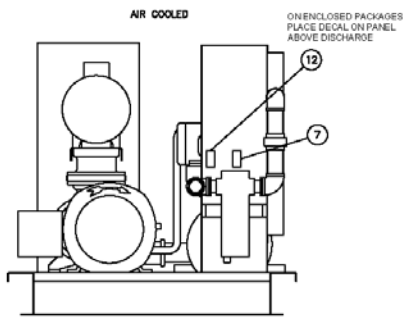
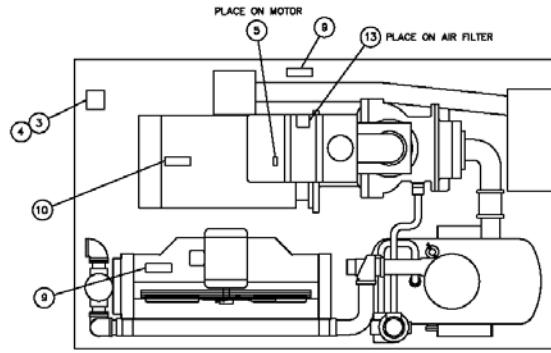

NOTE: DETAIL 18 ONE DECAL FRONT & BACK, BOTTOM EDGE
OF ENCLOSURE TOP FRAME & TOP EDGE OF DOOR.
(ENCLOSED PACKAGES ONLY)

316EBQ810-A
(Ref. Drawing)

IDENTIFICATION AND INSTRUCTION GROUP

B/M: 301EBQ4011
 303EBQ4011
 304EBQ4011
 309EAQ4011

Ref. No.	Name of Part	Qty.	Part No.
2	DECAL, ELECTRA SAVER II (LARGE)	3	VP1051551
* 5	DECAL, ROTATION ARROW	1	304EFC077
* 6	DECAL, ISO WARNING – CONTROL BOX.....	2	VP1009371
* 7	DECAL, ISO WARNING – MOISTURE TRAP	1	VP1009380
* 8	DECAL, ISO WARNING – SEPARATOR TANK	1	VP1009376
* 9	DECAL, ISO WARNING – FAN/COOLER HOUSING.....	2	VP1009582
* 10	DECAL, ISO WARNING – MOTOR	1	VP1009374
11	DECAL, OIL FILL ELEMENT INSTALL.....	1	326EAQ077
* 12	DECAL, ISO WARNING – PACKAGE DISCHARGE AIR	1	VP1009623
* 13	DECAL, NOTICE (USE GENUINE GD PARTS)	2	CC1009474
14	DECAL, GD LOGO (SMALL).....	1	VP1051555
15	DECAL, STRIPE (LARGE)	1	VP1051552
* 16	DECAL, ISO WARNING (SIDES ABOVE DOORS).....	2	VP1009372
18	DECAL, HEAT EXCHANGE “IN”	1	200ESP077
19	DECAL, HEAT EXCHANGE “OUT”	1	201ESP077

* For Replacement Decals Order Part Number CC1010403 Decal Group Sheet.

REPAIR KITS

Your Gardner Denver rotary screw compressor is designed and manufactured for many years of reliable operation. All components are engineered to exacting specifications, which will function together as a system to provide maximum efficiency. To insure the continuing integrity of compressor operation, use only original quality genuine Gardner Denver replacement parts and accessories.

Name of Part	Qty.	Part No.
ROUTINE MAINTENANCE KIT – HEAVY DUTY AIR FILTER		302EBU6013
ELEMENT, AIR FILTER.....	2	2118361
ELEMENT, OIL FILTER.....	3	2118342
SEPARATOR KIT		305EBQ6013
OIL SEPARATOR.....	1	VP1040693
GASKET ELIMINATOR	1	25BC222
LUBRICANT (OIL SEAL GREASE)	1	2116755
PNEUMATIC CONTROLS AND GAUGES		302EAQ6013
CHECK VALVE.....	3	90AR261
CONTROL VALVE.....	1	90AR1034
CONTROL VALVE.....	1	90AR1082
PRESSURE REGULATOR.....	1	88H367
PRESSURE GAUGE	1	2118767
ELECTRICAL CONTROL KIT.....		306EAQ6013
SOLENOID VALVE.....	1	91B70
SOLENOID VALVE.....	1	91B143
SOLENOID VALVE.....	1	91B144
THERMISTOR PROBE.....	2	21D264
TRANSDUCER.....	2	88H359
VACUUM SWITCH.....	1	88H195
WATER TEMPERATURE REGULATOR (Optional).....	1	90AR151
MAGNETIC WATER SHUTOFF VALVE – Nema 4 (Optional).....		91B173
TURN VALVE ACTUATOR O-RING KIT (EAU Only)		307EAQ6013
O-RING (TOP OF STEM)	2	25BC738
O-RING (BODY TO MANIFOLD, LARGE).....	2	25BC37
O-RING (BODY TO MANIFOLD, SMALL)	2	25BC35
O-RING (TUBE).....	2	2009224
BEARING KIT		331SSU6013
ROLLER BEARING	1	12BA52
ROLLER BEARING	1	12W34
BEARING.....	1	12BA252
ROLLER BEARING	1	12BA192
SPRING-WAVE	1	78W90
SPRING-WAVE	1	78W110
RETAINING RING	1	65W61
RETAINING RING	1	65W14
PERIODIC MAINTENANCE KIT (INLET VALVE)		301EAQ6013
O-RING.....	1	25BC298
SPRING	1	78W62
SPRING	1	78W61
O-RING.....	1	25AM30
RETAINING RING	1	74D89
GASKET ELIMINATOR	1	25BC222

REPAIR KIT (Continued)

Name of Part	Qty.	Part No.
GASKET KIT		334SSU6013
SHIM SET	1	77H116
SHIM SET	1	77H50
GASKET ELIMINATOR	1	25BC222
OIL SEAL KIT		324SSU6013
WEAR SLEEVE	1	80M28
OIL SEAL	1	60DD571
OIL SEAL	1	60DD689
O-RING	1	25BC205
CHECK VALVE	1	90AR923
PERIODIC OVERHAUL TURNVALVE KIT		335SSU6013
ROLLER BEARING	2	12BA51
SPRING	1	78W50
KEY	1	35C114
PACKING RING	4	60AM46
SEAL	2	60DD801
GASKET	4	25BC138N
BUMPER	2	32E15
RETAINER PLATE	2	300SSU168
RETAINING RING	2	74D49
SEAL	2	60DD65
WEAR SLEEVE INSTALLATION/REMOVAL KIT		302SSU4017
PULLER	1	200SSQ219
PLATE-PULLER	1	300SSU340
SCREW	1	655EE030
SCREW	1	655EE120A
SCREW	2	75D178
GUIDE	1	200SSU450
TOOL	1	200SSQ074
LUBRICANT (AEON 9000SP) – STANDARD		
5-GALLON PAIL	1	28H109
55-GALLON DRUM	1	28H110
LUBRICANT (AEON 9000TH)		
5-GALLON PAIL	1	28H286
55-GALLON DRUM	1	28H270
LUBRICANT (AEON 6000FG)		
5-GALLON PAIL	1	28H99
55-GALLON DRUM	1	28H100
LUBRICANT (AEON 6000FG-68)		
5-GALLON PAIL	1	28H314
55-GALLON DRUM	1	28H315
LUBRICANT (AEON BIO)		
5-GALLON PAIL	1	28H102
55-GALLON DRUM	1	28H103
TOUCH-UP PAINT		
5-GALLON PAIL (WHITE)	1	28H76
1-GALLON CAN (WHITE)	1	28H84
1-QUART CAN (WHITE)	1	28H83
5-GALLON PAIL (RED)	1	28H325
1-GALLON CAN (RED)	1	28H324
1-QUART CAN (RED)	1	28H323

Gardner Denver®

For additional information, contact your local representative or visit:
www.contactgd.com/compressors

©2012 Gardner Denver, Inc. Printed in U.S.A.

