

Rec'd 8/5/71

13-9-506

Parts List

**ELECTRA-SCREW®
STATIONARY
COMPRESSOR**

50 HP

**MODELS: ESJAA
ESJAB**

SERIAL NO. _____

13-9-506



GARDNER-DENVER COMPANY

QUINCY, ILLINOIS

TABLE OF CONTENTS

50 HP MODELS: ESJAA (FAN COOLED, With RADIATOR)
ESJAB (WATER COOLED, With HEAT EXCHANGER)

GROUP NAME	GROUP NO.
Ordering Instructions	139-A1-0
Compressor, Bare (Complete)	139-A1-1
Inlet Valve Assembly	139-A1-2
Air Filter Assembly	139-A1-2
Oil Reservoir Group	139-A3-3
Discharge Valve Assembly	139-A3-4
Minimum Pressure Valve Assembly	139-A3-4
Oil Piping Group: Fan-Cooled Units	139-A3-5 (F)
Water-Cooled Units	139-A3-5 (W)
Heat Exchanger Group (Water-Cooled Units Only)	139-A3-5 (W)
Mixing Valve Assembly	139-A1-6
Oil Filter Assembly	139-A1-6
Radiator Group (Fan-Cooled Units Only)	139-A3-7 (F)
Tubing Group (Oil & Air)	139-A1-8
Coupling	139-A1-9
Repair Items (Miscellaneous)	139-A1-9
Selective Items	139-A1-9
Optional Equipment	139-A1-9
Starter & Mounting Group	139-A3-10
Electrical Items (Miscellaneous)	139-A1-11
Control – Constant Speed: Panel	139-A1-12
Tubing	139-A1-12a
Control – Automatic Start-Stop (Panel & Tubing)	139-A1-13
Control – Dual Control (Panel & Tubing)	139-A1-14
Control – Duomatic: Panel	139-A1-15
Tubing	139-A1-15a
Recommended Spare Parts	139-A3-16

U.S.A. SERIAL NUMBERS
ESJAA – Serial No. 597281 thru
ESJAB – Serial No. 597693 thru

INSTRUCTIONS FOR ORDERING REPAIR PARTS

When ordering parts, specify Compressor **MODEL**, Method of Cooling, **HORSEPOWER** and **SERIAL NUMBER** (see name plate on unit). Serial Number is also stamped on top of the cylinder flange to the right of the inlet housing.

All orders for Parts should be placed with the nearest Sales and Service Office listed on the back cover of this book.

Where NOT specified, quantity of parts required per compressor or unit is one (1); where more than one is required per unit, quantity is indicated in parenthesis. **SPECIFY EXACTLY THE NUMBER OF PARTS REQUIRED.**

DO NOT ORDER BY SETS OR GROUPS.

To determine the Right Hand and Left Hand side of an Electra-Screw[®] compressor, stand at the motor end and look toward the compressor. Right Hand and Left Hand are indicated in parenthesis following part name, i.e. (RH) & (LH).

PARTS RETURNED

All claims must be made within five days after receipt of goods. If order has been filled correctly, we cannot allow the return of the goods without our consent and then only on a basis of a charge for service and rehandling plus transportation charges.

Transportation charges must be prepaid. If it is necessary to return a part to the factory for duplication or inspection, do not fail to do the following:

1. Write the nearest Sales and Service Office a letter advising what material you wish to return and why.
2. After receiving permission to return the item or items, obtain from the Sales and Service Office the correct forms filled out by that office for the proper return of material.
3. Place a tag in the package showing your name and address.
4. Tag each article in the box or package stating what and how many are returned.
5. Always give the serial number of the machine from which the parts were removed or the invoice number on which the parts were originally shipped.

All parts returned for credit should be handled in the same manner as that for duplication or inspection.

COMPRESSOR

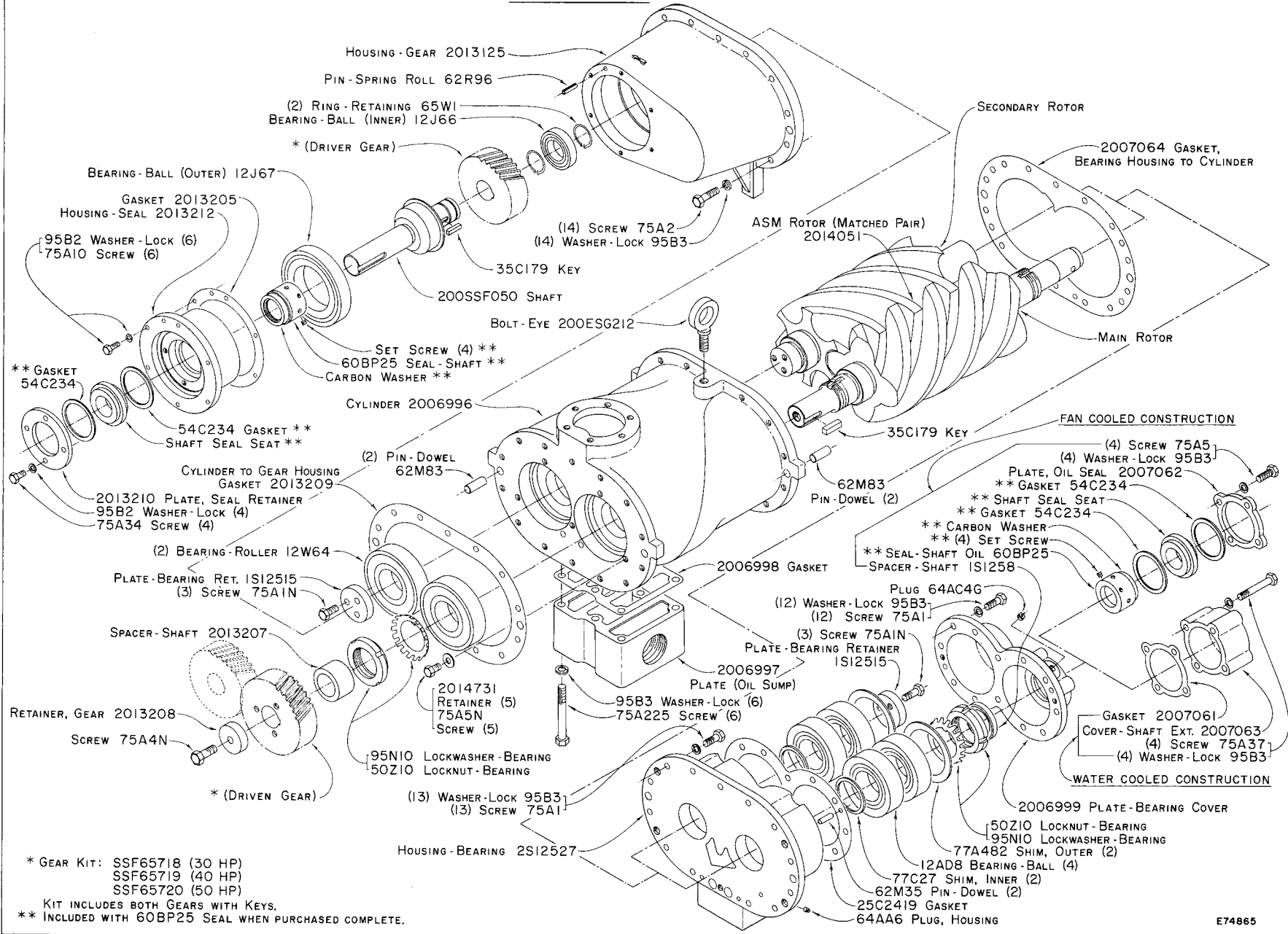

* GEAR KIT: SSF65718 (30 HP)
 SSF65719 (40 HP)
 SSF65720 (50 HP)
 KIT INCLUDES BOTH GEARS WITH KEYS.
 ** INCLUDED WITH 60BP25 SEAL WHEN PURCHASED COMPLETE.

E74865

139-A1-1

139-A1-1

INLET VALVE & AIR FILTER GROUP

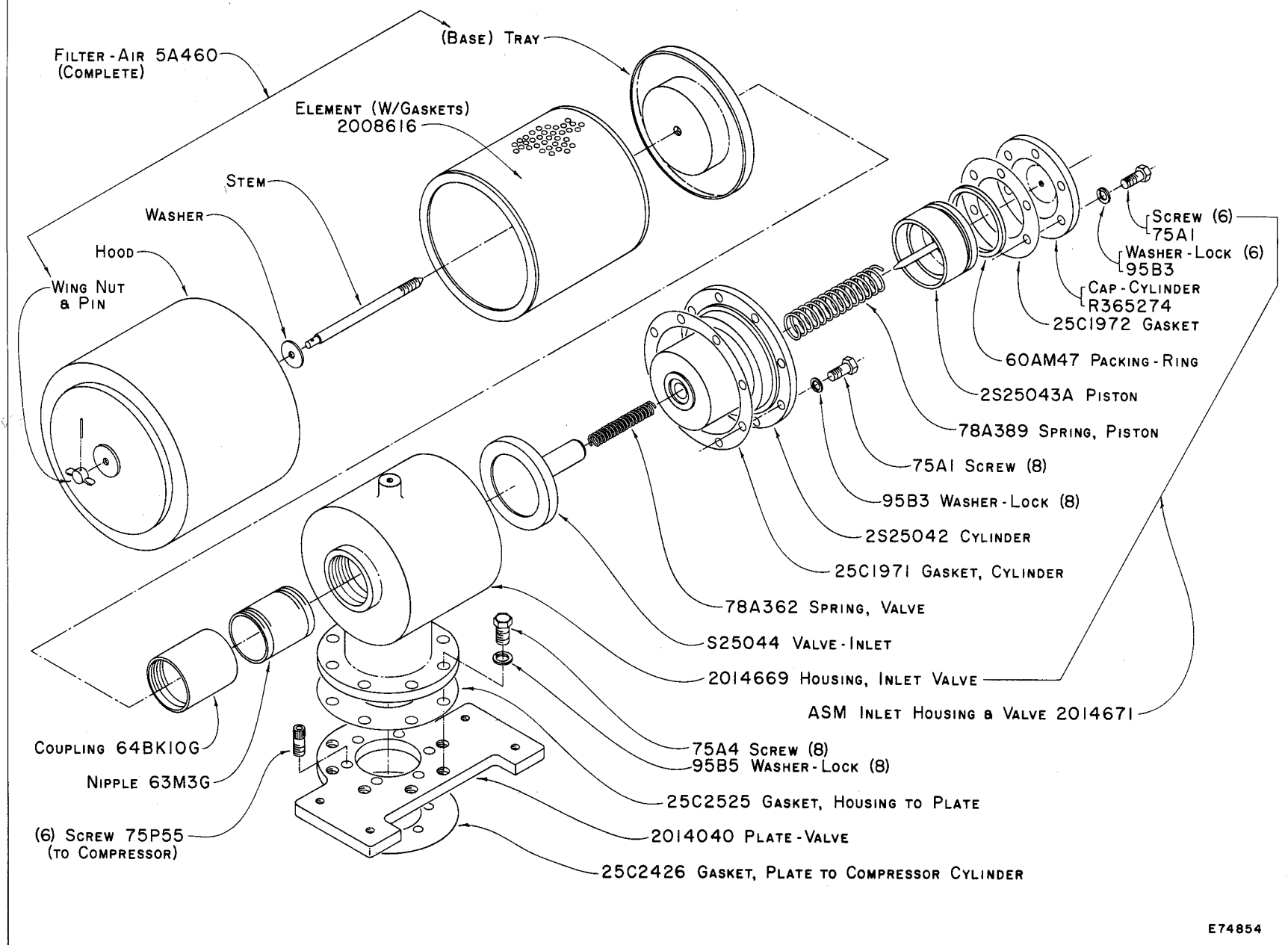

139-A1-2

FEBRUARY, 1971

139-A1-2

E74854

OIL RESERVOIR GROUP

MANIFOLD-DISCHARGE 201ESG071
(1/2") PLUG, MANIFOLD 64AA7G
(MINIMUM PRESS. DISCH. VALVE MOUNTING GROUP)

* VALVE-AIR CONTROL 90AR4
(1/4") PLUG, TOP 64B15G
(1-1/2") PLUG, SIDE 64B26G
NIPPLE-PIPE 63K18G
BUSHING-PIPE 64E12G
(MOTOR TO RESERVOIR)
(4) STUD 2014031
(8) NUT 50B5
(8) WASHER-LOCK 95B5
SHIM

(USE AS NEEDED)

∅ MOTOR SHIMS:
(.003) 77E11
(.008) 77E12
(.031) 77E13
(.062) 77E14

2009278 COUPLING
2010363 GASKET (w/RESTRAINING RING-2)

75A1 SCREW, TO COMPRESSOR (4)
95B3 WASHER-LOCK (4)

200ESG071 MANIFOLD-DISCHARGE

25C2428 GASKET

75A12 SCREW (4)
(RESERVOIR TO COMPRESSOR)
95B5 WASHER-LOCK (4)

2007010 FLANGE, RESERVOIR COVER
25F30 GASKET-RING (12)
75A88 SCREW (12)
2011711 GASKET, FLANGE **

ELBOW-STREET
64D9G

VALVE-SAFETY
90G261 (135#)

64D6G
ELBOW-STREET

64E9G
BUSHING-PIPE

64T46 PLUG (2"), OIL FILLER

200ESG037 RESERVOIR-OIL

OIL LEVEL GAUGE (SEE TUBING GROUP)

64BJ4G PLUG-MAGNETIC (3/4")

64AA6G PLUG (1/8"), PRESSURE CHECK (2)

64AA7G PLUG (1/2")

50W5 NUT-JAM (8)
(OPTIONAL EQUIPMENT)

2009375 LEVELER-LOAD (4)

63G1G NIPPLE-PIPE (2)

64AA3G PLUG (3/4"), RESERVOIR DRAIN (4)

64G7G TEE-PIPE (2)

* ASM DISCHARGE VALVE 2007107
(4) SCREW 75A68N
(VALVE TO RESERVOIR)
(4) RETAINER 2014731

200ESG715
** GASKET, SEPARATOR

** 200ESJ035 SEPARATOR-OIL
(w/NUT & WASHER)

* FOR COMPONENT PARTS OF DISCHARGE & MINIMUM PRESSURE VALVES SEE PAGE 139-A3-4.
** FOR REPAIR ORDER SEPARATOR KIT ESJ65644. KIT INCLUDES SEPARATOR & (2) GASKETS.

139-A3-3

DISCHARGE & MINIMUM PRESSURE VALVE ASSEMBLIES

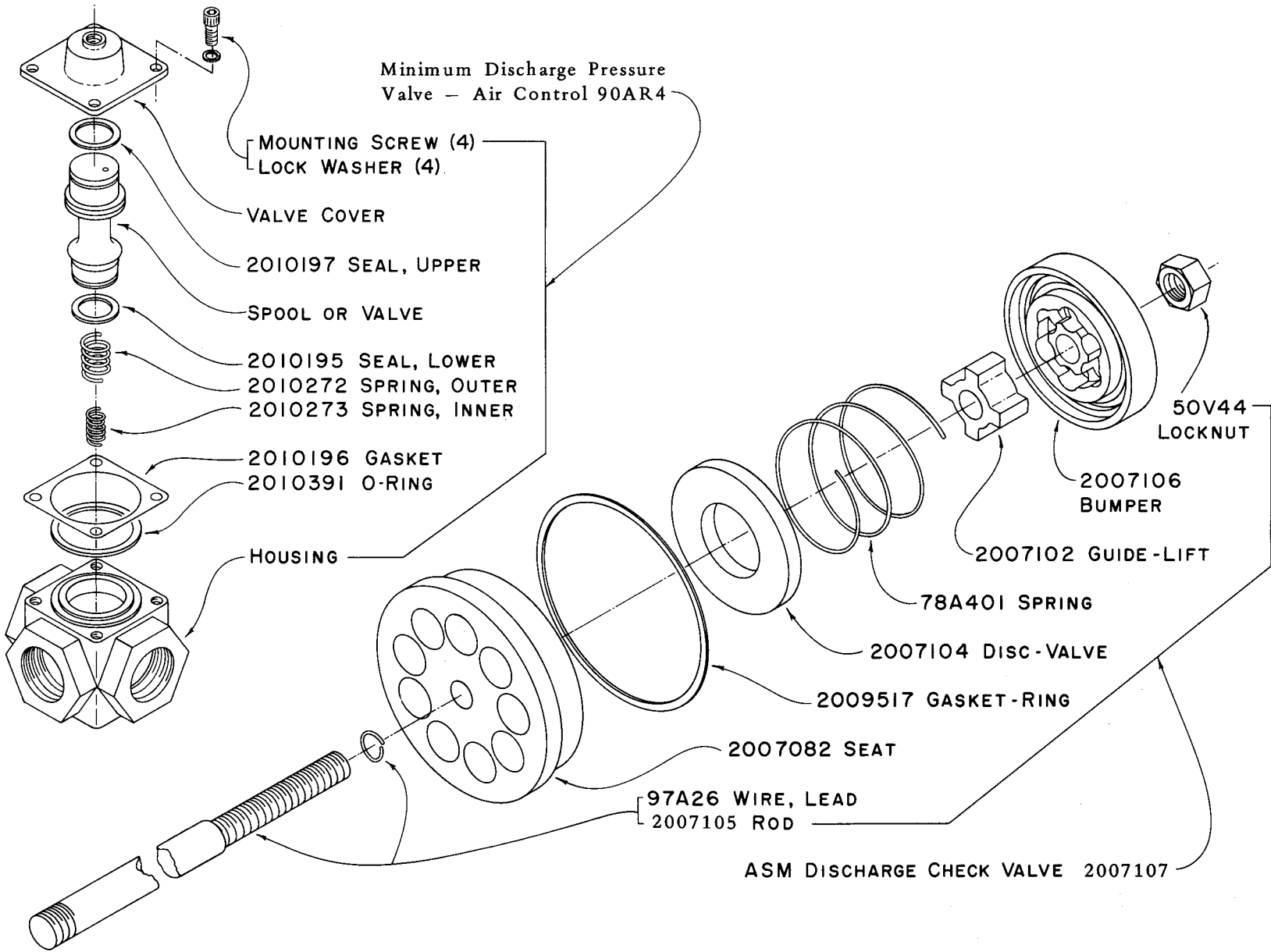

139-A3-4

OIL PIPING GROUP (FAN COOLED UNITS)

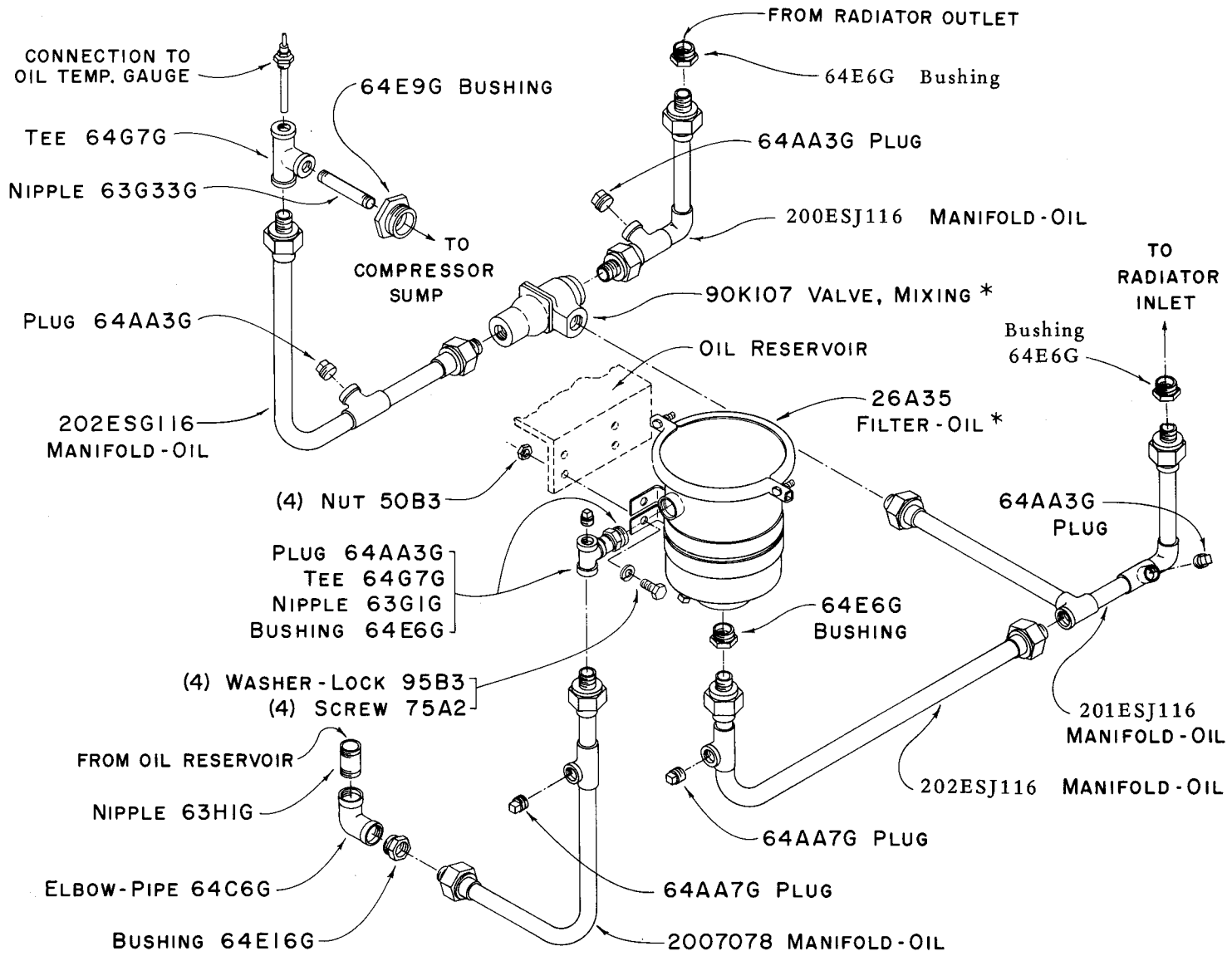

* FOR COMPONENT PARTS OF MIXING VALVE & OIL FILTER SEE PAGE 139-A1-6.

OIL & WATER PIPING GROUP (WATER-COOLED UNITS)

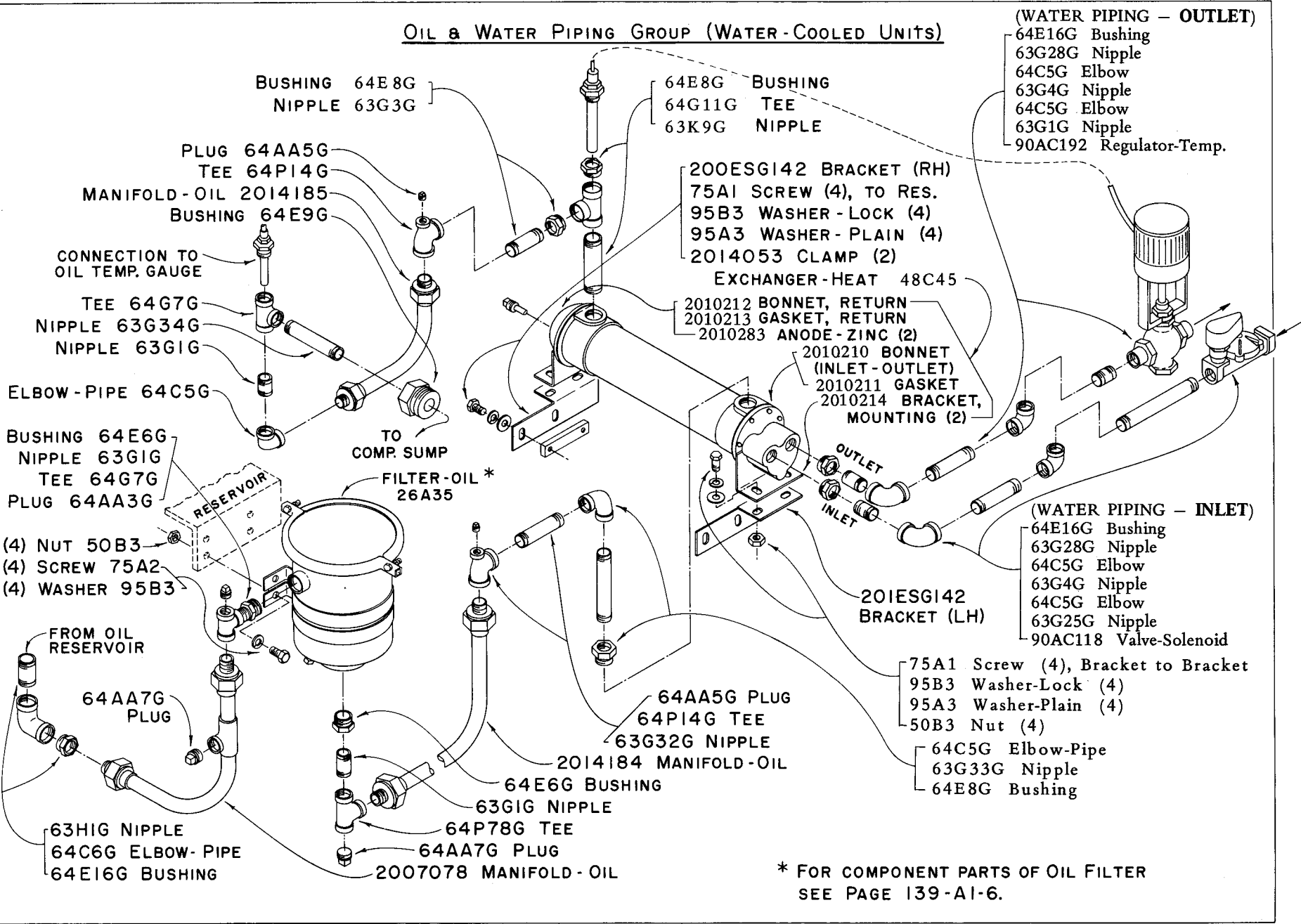

* FOR COMPONENT PARTS OF OIL FILTER SEE PAGE 139-A1-6.

139-A3-5 (W)

OIL FILTER & MIXING VALVE * ASSEMBLIES

139-A1-6

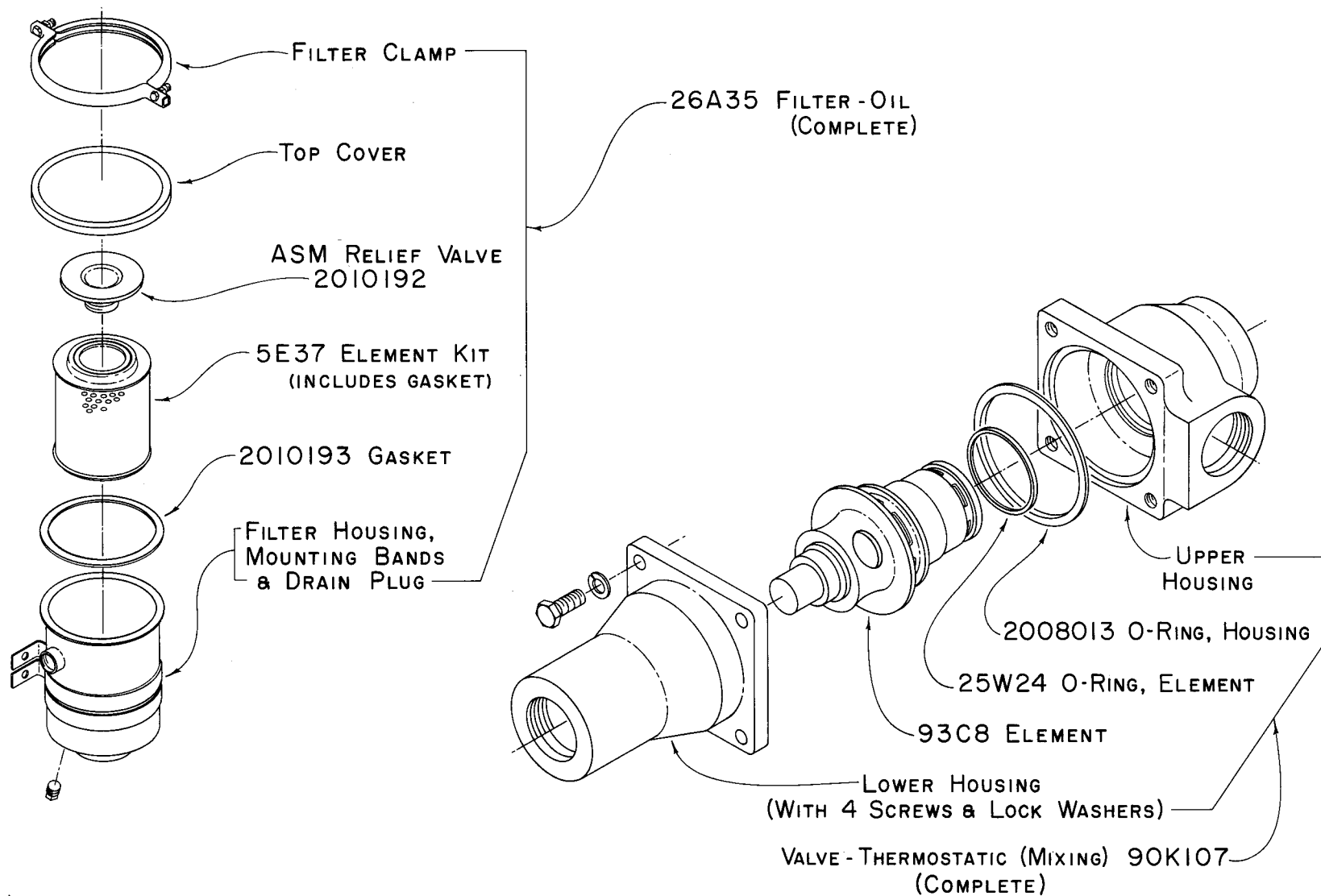

* MIXING VALVE NOT USED ON WATER-COOLED UNITS.

D74860

RADIATOR GROUP (FAN-COOLED UNITS ONLY)

(6) SCREW, SHROUD TO RADIATOR 75A130
(6) WASHER-LOCK 95B3

(FAN GUARD TO SHROUD)
(4) SCREW 75A2
(4) WASHER-LOCK 95B2
(4) WASHER-PLAIN 95A2
GUARD-FAN 200ESG393

SHROUD 200ESJ647
(4) RIVNUT 2009765
(4) SCREW, FAN TO HUB 75A33
(4) WASHER-LOCK 95B2
FAN 2014071
PIN-ROLL 62R163
HUB 2014563

(BRACE TO SHROUD)
75A5 SCREW
95B3 WASHER-LOCK
95A3 WASHER-PLAIN
200ESG326 BRACE

COMPRESSOR
EYE BOLT

MAIN ROTOR
(FAN SHAFT)

RADIATOR
200ESJ300

(6) RIVNUT
2009765

2014053 CLAMP (2)

50B2 NUT (2)
95B2 WASHER-LOCK (2)
75A10 SCREW (2), TO GUARD

201ESG017
BRACKET (LH)

RESERVOIR

200ESG017 BRACKET (RH)
75A5 SCREW (2), TO SHROUD
95B3 WASHER-LOCK (6)
95A3 WASHER-PLAIN (6)
75A1 SCREW (4), TO RESERVOIR

(2) PLUG, DRAIN
64AA5G

139-A3-7 (F)

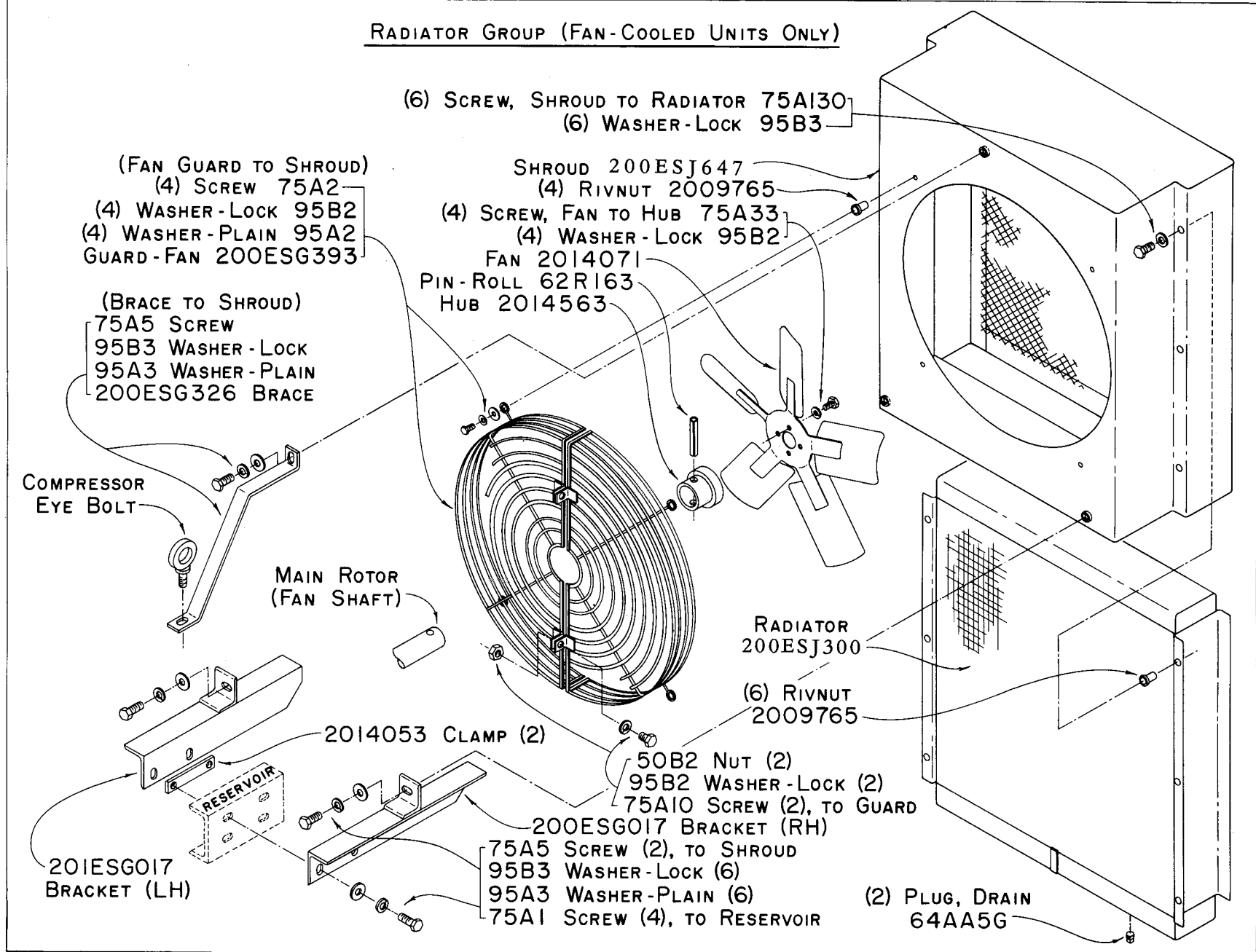

OIL & AIR TUBING AND PIPING (See Footnote)

PART NAME & DESCRIPTION	QUANTITY	30, 40, 50 HP
		PART NO.
(RESERVOIR THRU OIL LEVEL GAUGE TO RESERVOIR TEE)		
Elbow (1/4 P x 1/4 T x 90°), Bottom of Reservoir	(1)	86E60
Tube (1/4 x 11-5/8), to Gauge	(1)	2014714
Tube Kit, Oil Level Gauge (12" Lg. Tubing & 2 Unions)	(1)	2014841
Plate-Data, Oil Level Gauge	(1)	2007108
Tube (1/4 x 5-1/2), Gauge to Tee	(1)	2013084
Tee-Tube (1/4 T x 1/4 T x 1/4 MPT)	(1)	86E119
(RESERVOIR WET SUMP TO PIPELINE FILTER TO CROSS)		
Elbow (1/4 P x 1/4 T x 90°), In Reservoir	(1)	86E60
Tube (1/4 x 18), to Filter	(1)	2014719
Connector, Male (1/4 T x 1/4 P)	(1)	86E4
Filter-Pipeline (1/4 P x 1/4 P) *	(1)	65NF102LU
Bushing (1/4 x 1/8)	(1)	64E44
Nipple (1/8 x 3/4)	(1)	63C1
Cross-Pipe (1/8 PT)	(1)	2009487
Adaptor, Threaded (Cross to Reservoir)	(1)	2011458
Washer-Lock (5/16)	(1)	95B2
Nut-Hex (5/16)	(1)	50B2
(RESERVOIR DRY SUMP TO CROSS)		
Elbow (1/4 P x 1/4 T x 90°), In Reservoir	(1)	86E60
Tube (1/4 x 16-1/4)	(1)	2014713
Elbow (1/4 T x 1/8 MPT x 90°), In Orifice	(1)	86E59
(CROSS TO COMPRESSOR - OIL RETURN)		
Valve-Check (1/8 MPT x 1/4 T)	(1)	86N4
Tube (1/4 x 54-5/8)	(1)	2014711
Elbow (1/4 T x 1/8 MPT x 45°)	(1)	86E106
(RESERVOIR TO DUMP VALVE)		
Nipple (1/2 P x 5)	(1)	63F8G
Tee (1/2 P)	(1)	64G6G
Plug (1/2 P)	(1)	64AA7G
Nipple (1/2 P x 2)	(1)	63F2G
Valve-Solenoid (1/2 P)	(1)	90AC162
Orifice (1/2 P)	(1)	2011762
Muffler, Porous Type (1/2 P)	(1)	43F3
(RESERVOIR TO PRESSURE SWITCH)		
Tube (1/4 x 36)	(1)	85E4A360
Elbow-Tube (1/4 T x 1/4 P x 90°)	(1)	86E60
(RESERVOIR TO AIR PRESSURE GAUGE)		
Elbow (1/4 P x 1/4 T x 90°)	(1)	86E60
Tube (1/4 x 36)	(1)	85E4A360

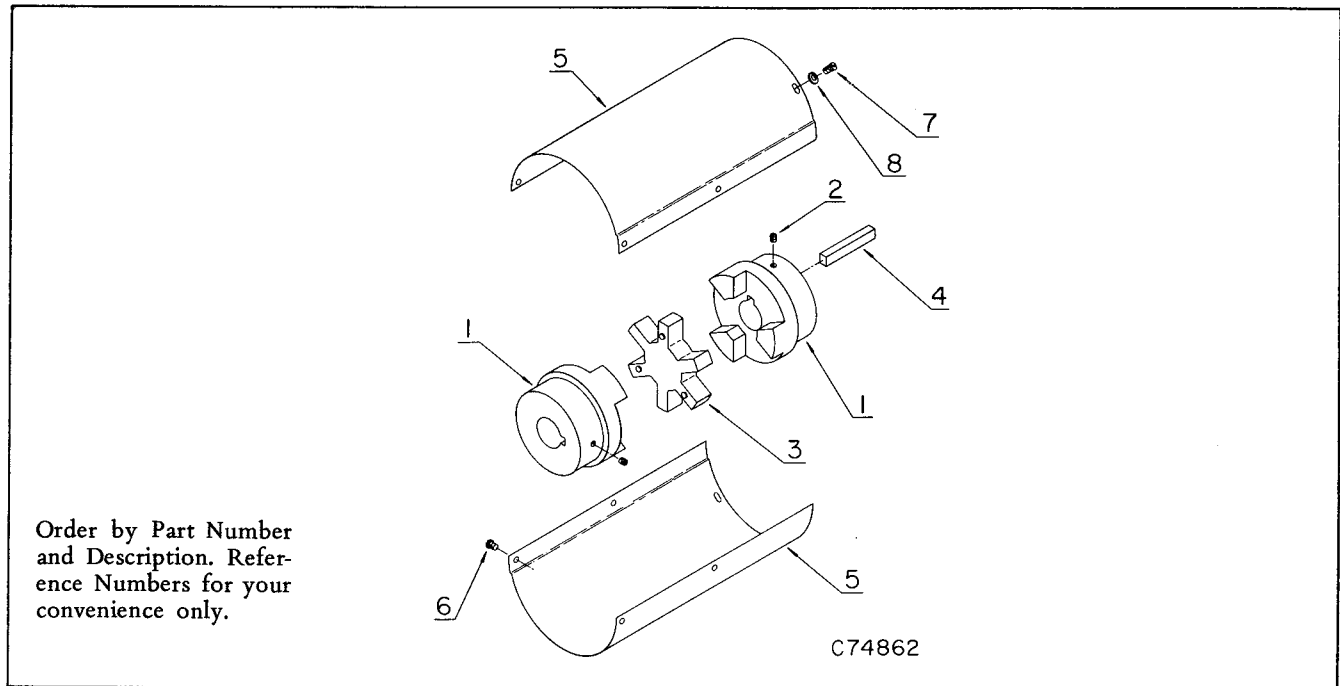

REF. NO.	PART NAME & DESCRIPTION	QUANTITY	30 HP PART NO.	40 HP PART NO.	50 HP PART NO.
COUPLING GROUP					
1	Coupling, Incl. Ref. No. 2 & 3	(1)	51K12	51K11	51K11
2	Set Screw	(2)	-----	-----	-----
3	Spider	(1)	2010385	2010218	2010218
4	Key (to Compressor)	(1)	35B35	35B35	35B35
5	Guard (Top & Bottom)	(2)	2014042	2014042	2014042
6	Screw, Guard (Top to Bottom)	(4)	2009368	2009368	2009368
7	Screw, Guard to Housing	(4)	75G8	75G8	75G8
8	Washer-Lock	(4)	95H33	95H33	95H33
ADDITIONAL REPAIR ITEMS					
Bare Compressor (Field Replacement):					
	Fan-Cooled Units	(1)	ESG65645	ESH65647	ESJ65649
	Water-Cooled Units	(1)	ESG65646	ESH65648	ESJ65650
	Gasket Kit (Bare Compressor)	(1)	SSF65632	SSF65632	SSF65632
Gasket Kit (Complete Unit, Less Motor, — Including Bare Compressor Kit):					
	Fan-Cooled Units	(1)	ESG65635	ESG65635	ESG65635
	Water-Cooled Units	(1)	ESG65633	ESG65633	ESJ65634
SELECTIVE ITEMS					
	Motor (230/460 V — 60 Hz)	(1)	24BB1	24BB3	24BB28
	Motor (200 V — 60 Hz)	(1)	24BB9	24BB10	24BB27
	Motor (575 V — 60 Hz)	(1)	24BB25	24BB29	24BB30
	Heater-Overload (230 V)	(3)	24T138	2009850	2009864
	Heater-Overload (460 V)	(3)	24T139	2009865	24CA105
	Heater-Overload (200 V)	(3)	24T147	2009864	2009864
	Heater-Overload (575 V)	(3)	2009863	24T139	2009865
	Transformer (230/460/575 V)	(1)	24CA43	24CA43	24CA43
	Transformer (208/277/380 V)	(1)	24CA44	24CA44	24CA44
	Starter (200-230 V)	(1)	2009860	2009861	2009861
	Starter (460-575 V)	(1)	2009860	2009860	2009860
OPTIONAL EQUIPMENT					
	Enclosure Group	(1)	ESG65712	ESG65712	ESG65712
	Air Filter Group (Heavy Duty)	(1)	ESG65734	ESG65734	ESG65734
	Instrument Panel Group (Pressure Drop)	(1)	ESG65740	ESG65740	ESG65740
	Load Leveler Group	(1)	ESG65787	ESG65787	ESG65787

STARTER & ENCLOSURE GROUP

PART NAME & DESCRIPTION	QUANTITY	50 HP
		PART NO.
Enclosure, Starter	(1)	2009859
Starter	(1)	*
Bracket, Enclosure	(1)	202ESG098
Screw (3/8 x 1-1/4), Bracket to Reservoir	(2)	75A2
Washer-Lock (3/8)	(2)	95B3
Nut-Hex (3/8)	(2)	50B3
Screw (1/4 x 3/4), Bracket to Enclosure	(3)	75A25
Washer-Plain (1/4)	(6)	95A1
Washer-Lock (1/4)	(3)	95B1
Nut (1/4)	(3)	50B1
STARTER TO MOTOR CONDUIT BOX		
Fitting-Conduit (2 x 90°)	(2)	2009339
Conduit, Flexible (2 x 24" - Cut at Assembly)	(1)	2009412
Wire (10' - No. 3/0 Ga. - Cut at Assembly)	(1)	2009522
Lug-Terminal (Cable Leads)	(3)	24A520
Lug-Terminal (Motor Leads)	(9)	24A307
Screw (3/8-16 x 3/4 Bronze), Motor Leads	(6)	2009538
Washer-Lock (3/8 Int. Tooth - Bronze)	(6)	95H18
Nut (3/8-16 Bronze)	(6)	50X15
STARTER (CENTER BOTTOM) TO CONTROL BOX		
Washer, Reducing (1-1/4 to 1)	(2)	24CA82
Fitting-Conduit (1 x 90°), Elbow	(2)	2009325
Conduit, Flexible (1 x 48" - Cut at Assembly)	(1)	2009314
Lug-Terminal (No. 6 Fork, No. 12 Wire, No. 6 Screw), to Transformer	(2)	24A517
Wire, No. 12 Ga. Black (15' - Cut at Assembly)	(1)	2009319
Wire, No. 14 GA. Red (80' - Cut at Assembly)	(1)	97HIR80

* See Selective Items, page 139-A1-9.

ELECTRICAL CONTROL ITEMS (MISCELLANEOUS)

PART NAME & DESCRIPTION	QUANTITY	30, 40, 50 HP
BLOWDOWN VALVE (SOLENOID) TO UNILET TEE		
		PART NO.
Fitting-Conduit, Straight (1/2)	(1)	24A378
Conduit, Flexible (1/2 x 8 - Cut at Assembly)	(1)	24A402
Fitting-Conduit, Straight (1/2)	(1)	24A378
Fitting-Conduit (Unilet Tee)	(1)	24A341
Gasket, Unilet Tee	(1)	24A342
Cover, Unilet Tee	(1)	24A343
UNILET TEE TO HI TEMPERATURE SWITCH		
Connector-Box (1/2)	(1)	2009927
Switch, High Temperature Shutdown	(1)	21B90
Lug-Terminal (No. 14 Wire, No. 8 Screw)	(2)	24A476
Screw-Machine (No. 8-32 x 1/4)	(2)	75G17
Nut-Hex Machine (No. 8-32)	(2)	50K8
UNILET TEE (SIDE) TO CONTROL BOX		
Fitting-Conduit (1/2 x 45°)	(1)	24A379
Conduit (1/2 x 36 - Cut at Assembly)	(1)	24A402
Fitting-Conduit (1/2 x 90°)	(1)	24A380
CONTROL BOX CONNECTIONS		
Connector-Female, Spade (10-12 Wire)	(1)	24A377
Connector-Female, Spade (14-16 Wire)	(5)	24CA45
Lug-Terminal (No. 10 Fork)	(4)	24A477
Lug-Terminal (No. 6 Fork, 10-12 Wire)	(1)	24A517
Lug-Terminal (No. 6 Fork, 14-16 Wire)	(8)	24A478
Lug-Terminal (No. 8 Fork)	(4)	24A476
Wire, No. 14 Ga. Green (12" - Cut at Assembly)	(1)	97HIG1
Wire, No. 14 Ga. Red (84" - Cut at Assembly)	(1)	97HIR10
Tie-Cable	(12)	24A461
WATER SOLENOID TO CONTROL PANEL *		
Nipple (1/2")	(1)	24A503
Locknut (1/2")	(1)	24A77
Fitting-Conduit (Elbow)	(1)	24A486
Conduit (1/2 x 13 - Cut at Assembly)	(1)	24A402
Fitting-Conduit (1/2 - Straight)	(1)	24A378
Fitting-Conduit (1/2 - Elbow)	(1)	24A380
Lug-Terminal (No. 14 Wire, No. 8 Screw)	(4)	24A487
Screw (No. 8-32 x 1/4)	(2)	75G17
Nut (No. 8-32)	(2)	50K8

* Used only on water-cooled units.

CONTROL PANEL GROUP (CONSTANT SPEED) *

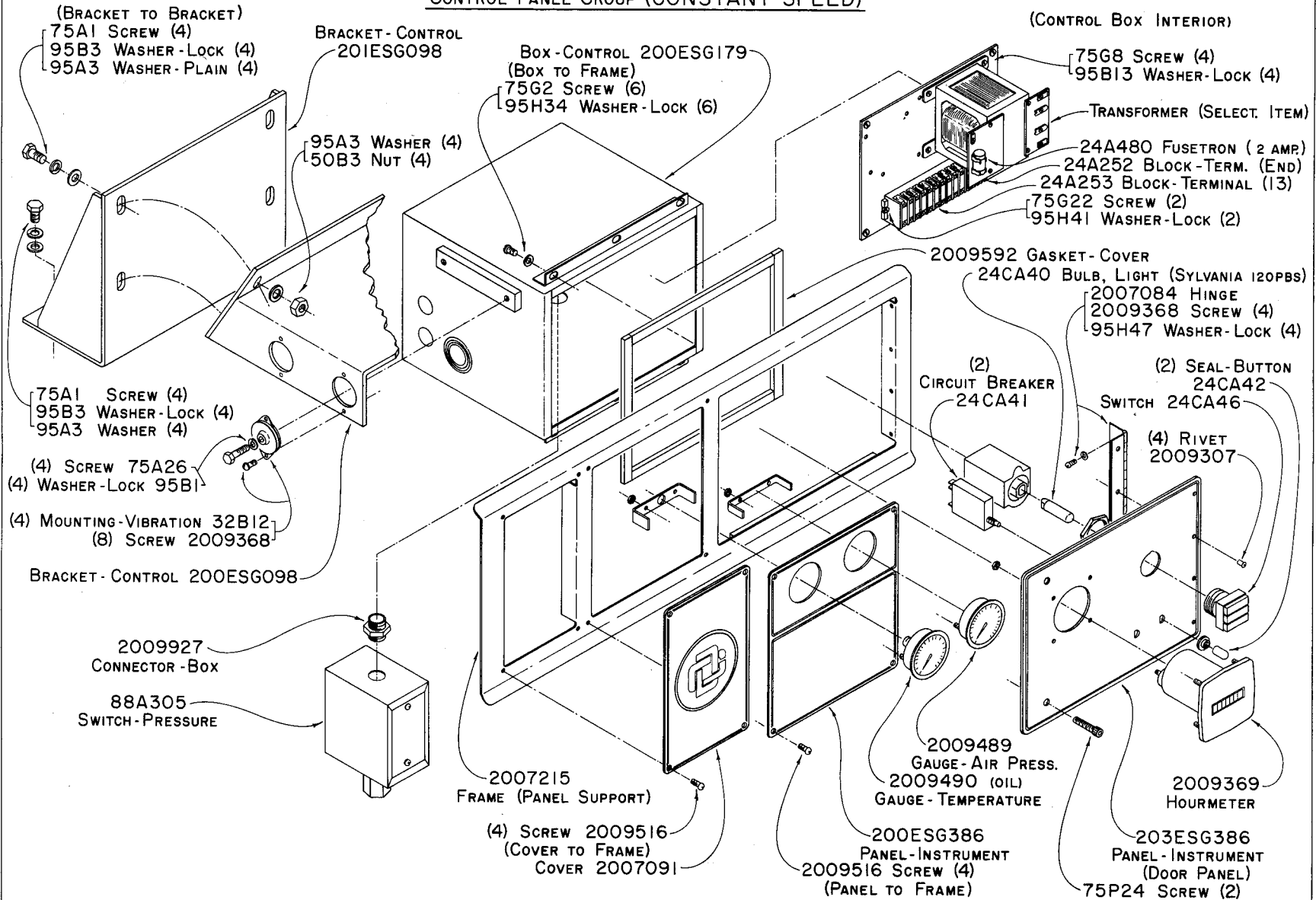

139-A1-12

* FOR CONSTANT SPEED CONTROL TUBING SEE PAGE 139-A1-12A.

E74870

C74867

CONTROL TUBING (CONSTANT SPEED)

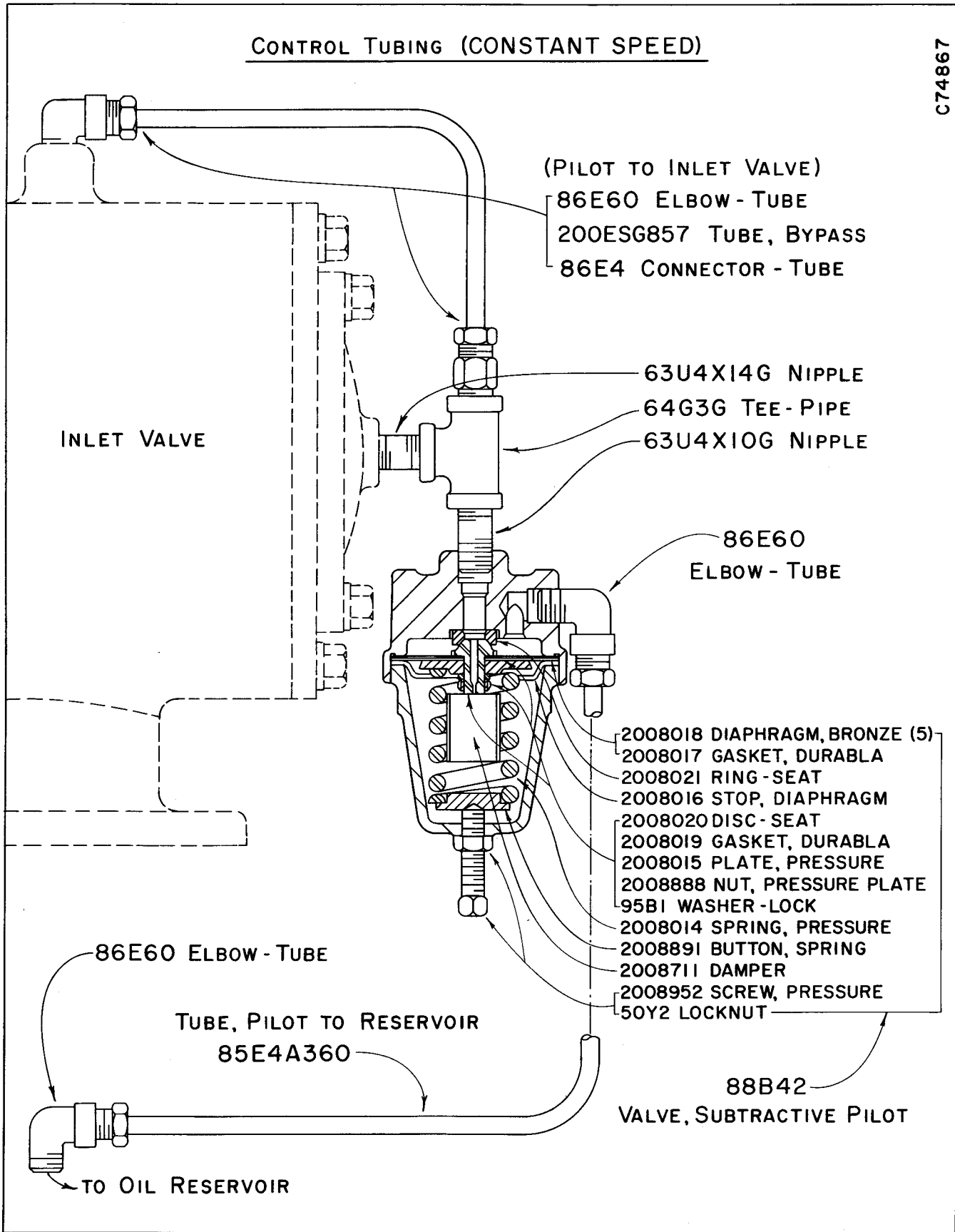

CONTROL PANEL GROUP (AUTOMATIC START-STOP)

139-A1-13

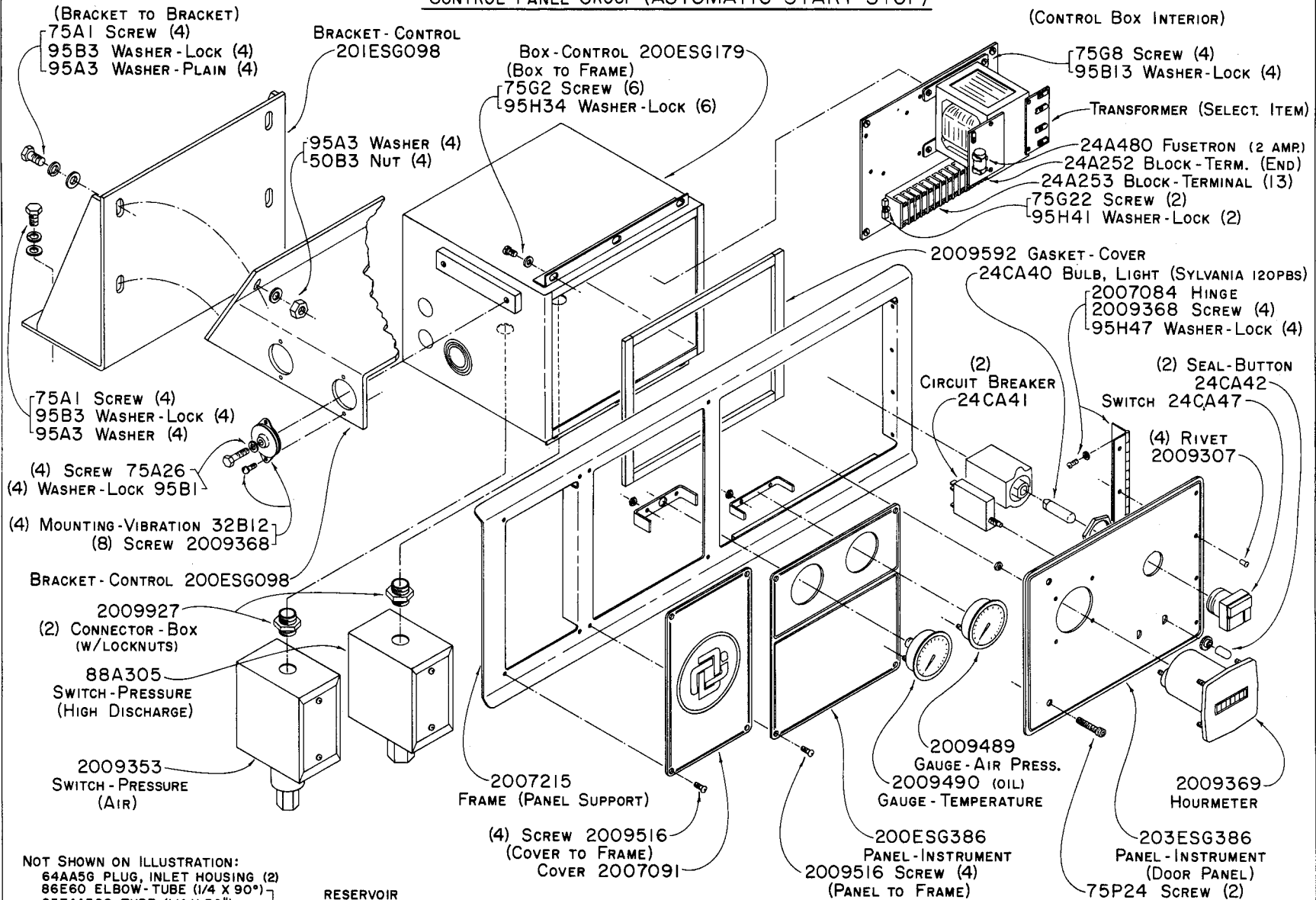

NOT SHOWN ON ILLUSTRATION:

- 64AA5G PLUG, INLET HOUSING (2)
 - 86E60 ELBOW-TUBE (1/4 X 90°)
 - 85E4A360 TUBE (1/4 X 36")
 - 86E60 ELBOW-TUBE (1/4 X 90°)
 - 97HIRI WIRE, RED (14 GA. --12" LONG)
 - 24A476 LUG-TERMINAL (#8 FORK-- FOR AIR PRESSURE SWITCH) (2)
- RESERVOIR TO PRESSURE SWITCH
- (Reservoir to Ejector to Blowdown Valve Tee) -- same as page 139-A1-15a except Tubing to Tee is Part No. 85E4A480.

E74889

CONTROL PANEL GROUP (DUAL CONTROL)

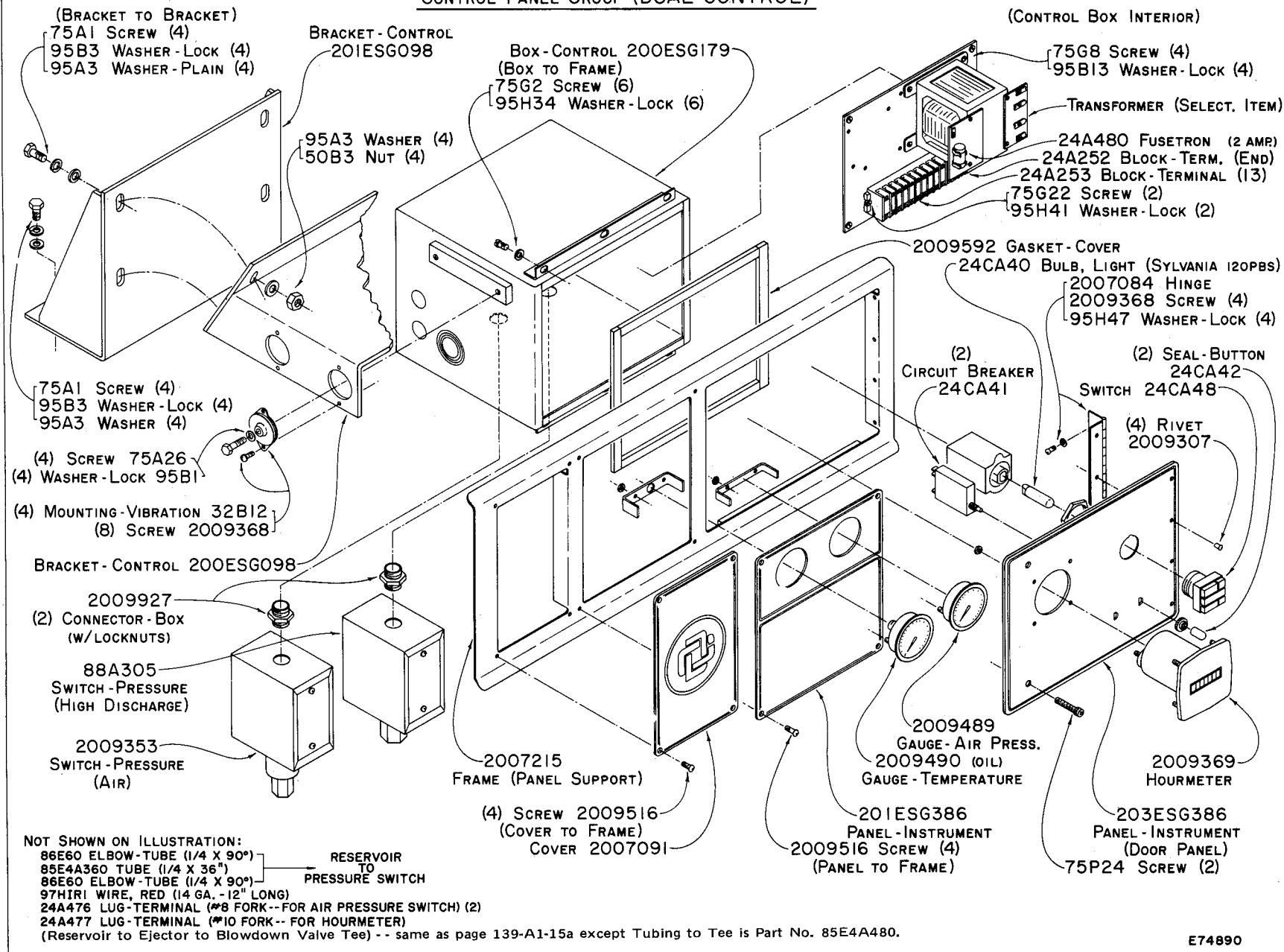

139-A1-14

CONTROL PANEL GROUP (DUOMATIC) *

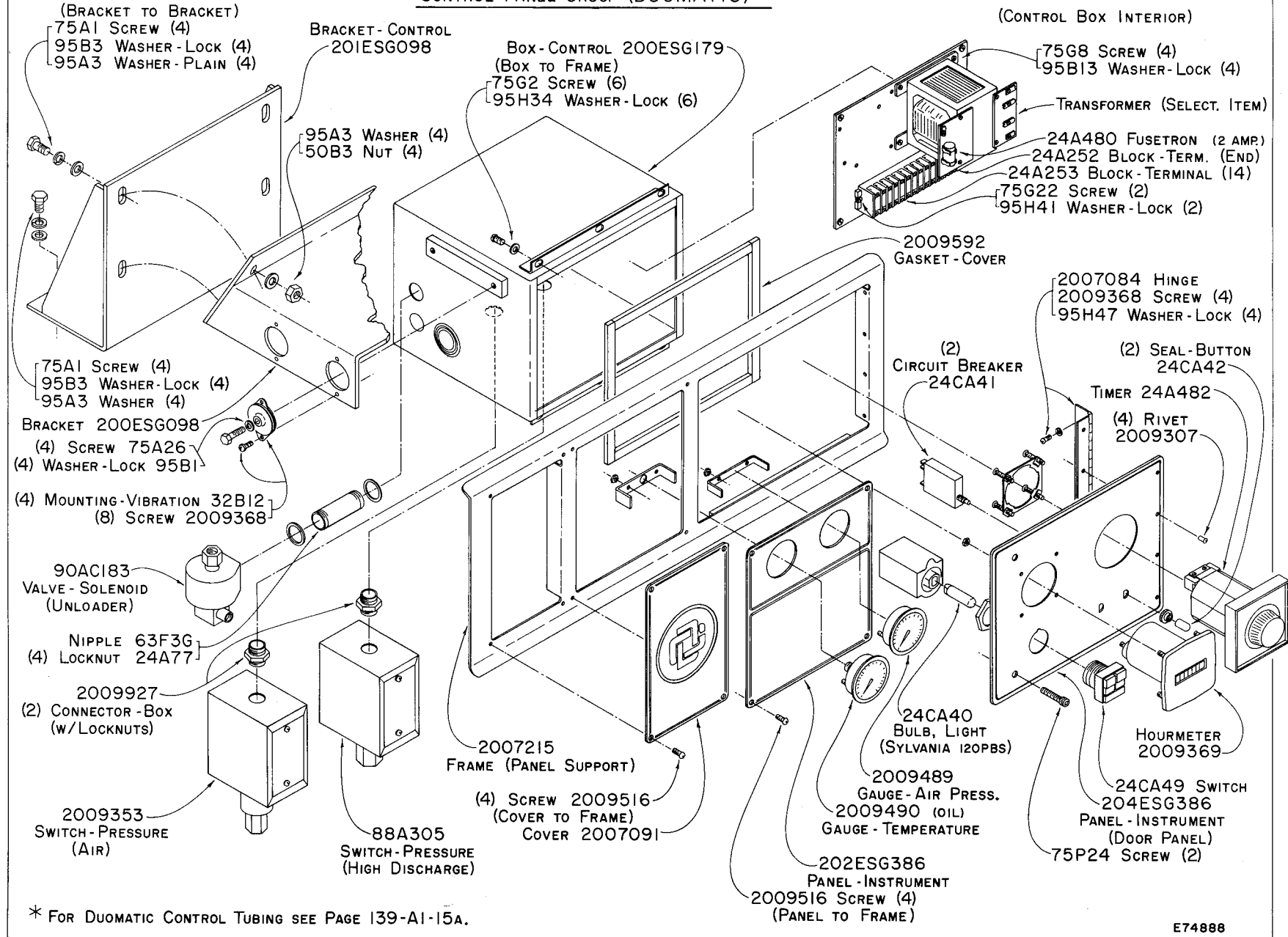

139-A1-15

CONTROL TUBING (DUOMATIC)

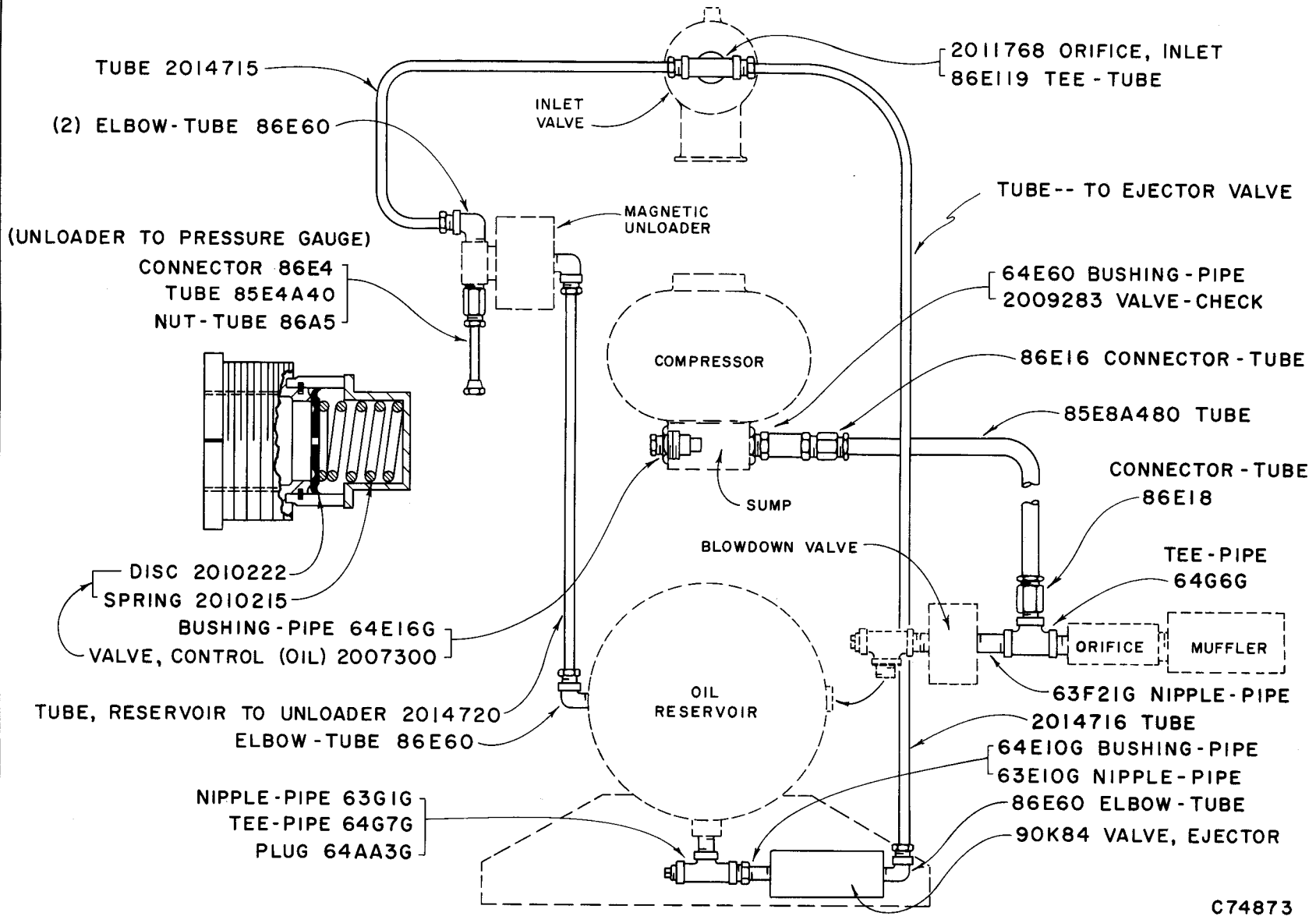

C74873

139-A1-15A

GARDNER-DENVER COMPRESSOR

FEBRUARY, 1971

139-A1-15A

RECOMMENDED SPARES – MODELS ESJAA & ESJAB

The following kits are separated according to service and locations. These are made available to aid the customer in stocking parts to allow on-site maintenance and/or Repair. Quantities shown are for one unit only. It is the responsibility of the Owner-Operator to apply a multiplier for multiple units, operating conditions and/or for hours of operation. Refer to Instruction Manual for recommended replacement time for critical parts. **KITS DO NOT INCLUDE OIL SEPARATORS, ELECTRICAL OR CONTROL ITEMS – THESE MUST BE PURCHASED SEPARATELY.**

Ordering Instructions

KIT NO. 1 – Routine Maintenance: These are suggested as the minimum quantity of parts a customer should stock. They are usually the first items which require renewal. Order quantities of this kit to suit your requirements or particular service. One kit contains three (3) oil filter elements which require changing at least every 1000 hours under normal conditions.

KIT NO. 2 – Domestic Service: These are suggested as the minimum spares a customer should stock for continuous operation for one year. When ordering for this service, order Kits No. 1 and 2.

KIT NO. 3 – Isolated Domestic or Export Service: These are suggested as the minimum spares a customer should stock for continuous operation. These parts include those which possibly would need renewal in an overhaul. When ordering for this service, order Kits No. 1, 2 and 3.

APPLY THE PROPER MULTIPLIER BASED ON NUMBER OF UNITS AND HOURS OF OPERATION;
 Example: For four (4) units, Four (4) of Kit No. 1 and only One (1) each of Kits 2 and 3 may be sufficient.

COMPRESSOR MODEL		ESJAA & ESJAB	ESJAA	ESJAB	ESJAA	ESJAB
HOURS OF OPERATION		3000	9000	9000	18000	18000
PART NO. (COMPLETE KIT)		ESJ65637	ESG65639	ESG65638	ESJ65796	ESJ65642
		KIT NO. 1	KIT NO. 2		KIT NO. 3	
Description	Page No.	Qty. Per Kit	Qty. Per Kit		Qty. Per Kit	
KIT NO. 1 – ROUTINE MAINTENANCE						
Air Filter Element	139-A1-2	1				
Oil Filter Element Assembly	139-A1-6	3				
KIT NO. 2 – DOMESTIC SERVICE						
Shaft Seal (Inlet End)	139-A1-1		1	1		
Shaft Seal (Discharge End)	139-A1-1		1			
Inlet Valve	139-A1-2		1	1		
Inlet Valve Piston Spring	139-A1-2		1	1		
Inlet Valve Spring	139-A1-2		1	1		
Inlet Valve Block Vee Packing (Set)	139-A1-2		1	1		
Minimum Discharge Pressure Valve Springs (Inner & Outer), Seals (Upper & Lower) & Gasket	139-A3-4		1 ea.	1 ea.		
Discharge Manifold Gasket	139-A3-3		1	1		
Thermostat Mixing Valve Element	139-A3-5 (F)		1			
Mixing Valve Element O-Ring	139-A3-5 (F)		1			
Mixing Valve Housing O-Ring	139-A3-5 (F)		1			
Gasket Kit (Bare Compressor)	139-A1-9		1	1		
KIT NO. 3 – ISOLATED DOMESTIC OR EXPORT SERVICE						
Gear Drive Ball Bearing (Inner)	139-A1-1				1	1
Gear Drive Ball Bearing (Outer)	139-A1-1				1	1
Roller Bearing	139-A1-1				2	2
Angular Contact Ball Bearing	139-A1-1				4	4
Discharge Valve Assembly	139-A3-4				1	1
Gasket Kit (Complete Unit, Less Motor)	139-A1-9				1	1

SALES AND SERVICE OFFICES

UNITED STATES and MEXICO

ATLANTA (STONE MOUNTAIN), GEORGIA - 30083
1545 Mountain Industrial Blvd.
BAKERSFIELD, CALIFORNIA - 93308
3506 Gilmore Avenue
BALTIMORE (ELLCOTT CITY), MARYLAND - 21043
3515 Chevrolet Drive
BIRMINGHAM, ALABAMA - 35209
817 Green Springs Highway
BOISE, IDAHO - 83706
3422 Americana Terrace
BOSTON (NEEDHAM HEIGHTS), MASSACHUSETTS - 02194
65 Crawford Street
BUFFALO, NEW YORK - 14226
4532 Bailey Avenue
BUTTE, MONTANA - 59701
215 East Park Street
CASPER, WYOMING - 82601
310 North 2nd Avenue
CHARLOTTE, NORTH CAROLINA - 28211
723 South Sharon Amity Road
CHICAGO (BROADVIEW), ILLINOIS - 60153
2535 S. 25th Avenue
CINCINNATI (SPRINGDALE), OHIO - 45246
12145 Centron Place
CLEVELAND, OHIO - 44125
5400 Warner Road
CORPUS CHRISTI, TEXAS - 78408
4512 Baldwin Blvd.
DALLAS, TEXAS - 75226
4700 Scyene Road
DENVER, COLORADO - 80216
3801 East 50th Avenue
DETROIT (OAK PARK), MICHIGAN - 48237
12700 Capital Avenue
DULUTH, MINNESOTA - 55811
3185 Miller Trunk Highway
EL PASO, TEXAS - 79902
1230 Wyoming Avenue
GRAND JUNCTION, COLORADO - 81501
2909 North Avenue
HARTFORD (BLOOMFIELD), CONNECTICUT - 06002
81 Old Windsor Road
HOUSTON, TEXAS - 77027
3325 South Rice Avenue
INDIANAPOLIS, INDIANA - 46203
2228 Shelby Street
KANSAS CITY (SHAWNEE MISSION), KANSAS - 66201
9101 Bond Street

KNOXVILLE, TENNESSEE - 37917
709 North Fifth Avenue
LAFAYETTE, LOUISIANA - 70501
200 Vanway Street
LOS ANGELES (WHITTIER), CALIFORNIA - 90601
2555 Pellissier Place
LOUISVILLE, KENTUCKY - 40207
4050 Westport Road
MILWAUKEE, WISCONSIN - 53226
11800 West Ripley Avenue
MINNEAPOLIS, MINNESOTA - 55431
1701 West 80th Street
NEW ORLEANS (HARVEY), LOUISIANA - 70058
1100 Destrehan Avenue
NEW YORK DOMESTIC (MAHWAH, NEW JERSEY) - 07430
386 State Highway No. 17
ODESSA, TEXAS - 79760
East Highway 80
OKLAHOMA CITY, OKLAHOMA - 73129
2200 South Prospect Avenue
PHILADELPHIA (HORSHAM) PENNSYLVANIA - 19044
406 Caredean Drive
PHOENIX, ARIZONA - 85009
2020 N. Black Canyon Highway
PITTSBURGH, PENNSYLVANIA - 15205
Parkway West - 4499 Campbells Run Road
QUINCY, ILLINOIS - 62301
So. Gardner Expressway
ST. LOUIS (BRIDGETON), MISSOURI - 63044
140 Boulder Industrial Drive
SALT LAKE CITY, UTAH - 84115
35 West Louise Avenue
SAN DIEGO, CALIFORNIA - 92123
5345 Overland Avenue
SAN FRANCISCO (SOUTH SAN FRANCISCO), CALIFORNIA - 94080
144 West Harris Avenue
SEATTLE, WASHINGTON - 98104
623 Eighth Avenue, South
SHREVEPORT, LOUISIANA - 71107
1025 Joseph Street
TULSA, OKLAHOMA - 74145
4259 So. 76th East Avenue
WALLACE, IDAHO - 83873
502 Bank Street
MEXICO 1, D. F. MEXICO
Apartado 575

CANADA

GARDNER-DENVER COMPANY (CANADA), LIMITED

EDMONTON, ALBERTA - 9835 - 42 Ave. - Zone 72
MONCTON, NEW BRUNSWICK - East Main St.
MONTREAL 28, Quebec - 5826 St. James St., West
NORTH BAY, ONTARIO - 693 Casse Ils St.

SUDBURY, ONTARIO - 1369 LaSalle Blvd., East
TORONTO (SCARBOROUGH), ONTARIO -
1800 Elasmere Road
VANCOUVER 9, BRITISH COLUMBIA - 1775 Pine St.
WINNIPEG 21, MANITOBA - 1380 Sargent Ave.

INTERNATIONAL

GARDNER-DENVER INTERNATIONAL -- QUINCY, ILLINOIS
GARDNER-DENVER INTERNATIONAL -- 386 State Highway No. 17
Mahwah, New Jersey 07430

ARGENTINA -- BUENOS AIRES
AUSTRALIA -- SYDNEY, MELBOURNE, HOBART, BRISBANE,
ADELAIDE, PERTH, KALGOORLIE, MOUNT ISA
BELGIUM -- BRUSSELS
BRAZIL -- BELO HORIZONTE, RIO DE JANEIRO,
SAO PAULO
CHILE -- SANTIAGO
COLOMBIA -- BARRANQUILLA, BOGOTA
CONGO -- LUBUMBASHI
GREECE -- ATHENS

HOLLAND -- SCHIPHOL
ITALY -- MILAN
NEW ZEALAND -- OTARA (AUCKLAND)
PERU -- LIMA
REPUBLIC OF SINGAPORE -- SINGAPORE
SOUTH AFRICA -- CAPE TOWN, JOHANNESBURG,
PORT ELIZABETH, WINDHOEK
SWEDEN -- STOCKHOLM, GÖTEBORG
UNITED KINGDOM -- LONDON
VENEZUELA -- CARACAS, PUERTO ORDAZ
ZAMBIA -- NDOLA

FACTORIES

DALLAS, TEXAS
DENVER, COLORADO
GRAND HAVEN, MICHIGAN
GREEN BAY, WISCONSIN
LA GRANGE, MISSOURI
QUINCY, ILLINOIS

REED CITY, MICHIGAN
YORK, PENNSYLVANIA
JOHANNESBURG, S. AFRICA
RIO DE JANEIRO, BRAZIL
WOODSTOCK, ONTARIO, CANADA
WESTHAUSEN, GERMANY



GARDNER-DENVER COMPANY

QUINCY, ILLINOIS

LITHO - IN U.S.A.