

---

---

**GARDNER DENVER<sup>®</sup>**

13-8-629  
1st Edition  
September 1, 2000

**ELECTRA-SCREW<sup>®</sup>  
STATIONARY BASE-MOUNTED  
COMPRESSOR**

**MODELS – EDE99M**

**40 & 50 HP**

**OPERATING AND  
SERVICE MANUAL**

**Gardner**  

---

**Denver**

**MAINTAIN COMPRESSOR RELIABILITY AND PERFORMANCE WITH  
GENUINE GARDNER DENVER® COMPRESSOR PARTS AND SUPPORT SERVICES**

Gardner Denver Compressor genuine parts, manufactured to design tolerances, are developed for optimum dependability – specifically for Gardner Denver compressor systems. Design and material innovations are the result of years of experience with hundreds of different compressor applications. Reliability in materials and quality assurance is incorporated in our genuine replacement parts.

Your authorized Gardner Denver Compressor distributor offers all the backup you'll need. A worldwide network of authorized distributors provides the finest product support in the air compressor industry. Your local authorized distributor maintains a large inventory of genuine parts and he is backed up for emergency parts by direct access to the Master Distribution Center (MDC) in Memphis, Tennessee.

Your authorized distributor can support your Gardner Denver air compressor with these services:

1. Trained parts specialists to assist you in selecting the correct replacement parts.
2. Factory warranted new and remanufactured rotary screw airends. Most popular model remanufactured airends are maintained in stock at the Remanufacturing Center in Indianapolis, IN., for purchase on an exchange basis with liberal core credit available for the replacement unit.
3. A full line of factory tested AEON™ compressor lubricants specifically formulated for use in Gardner Denver compressors.
4. Repair and maintenance kits designed with the necessary parts to simplify servicing your compressor.

Authorized distributor service technicians are factory trained and skilled in compressor maintenance and repair. They are ready to respond and assist you by providing fast, expert maintenance and repair services.

**For the location of your local authorized Gardner Denver Air Compressor distributor, refer to the yellow pages of your phone directory or contact:**

**Distribution Center:**

Gardner Denver  
Master Distribution Center  
5585 East Shelby Drive  
Memphis, TN 38141  
Phone: (901) 542-6100  
(800) 245-4946  
Fax: (901) 542-6159

**Factory:**

Gardner Denver  
1800 Gardner Expressway  
Quincy, IL 62301  
Phone: (217) 222-5400  
Fax: (217) 224-7814

**REMANUFACTURED AIRENDS**

Whenever an airend requires replacement or repair, Gardner Denver offers an industry unique, factory remanufactured airend exchange program. From its modern Remanufacturing Center in Indianapolis, IN., Gardner Denver is committed to supplying you with the highest quality, factory remanufactured airends that are guaranteed to save you time, aggravation and money.

**Immediately Available**

Repair downtime costs you money, which is why there are over 200 remanufactured units in inventory at all times, ready for immediate delivery.

**Skilled Craftsmen**

Our Remanufacturing assembly technicians average over 20 years experience with air compression products.

**Precision Remanufacturing**

All potentially usable parts are thoroughly cleaned, inspected and analyzed. Only those parts that can be brought back to original factory specifications are remanufactured. Every remanufactured airend receives a new overhaul kit: bearings, gears, seals, sleeves and gaskets.

**Extensive Testing**

Gardner Denver performs testing that repair houses just don't do. Magnaflux and ultrasonic inspection spot cracked or stressed castings, monochromatic light analysis exposes oil leaks, and coordinate measurement machine inspects to +/- .0001", insuring that all remanufactured airends meet factory performance specifications.

**Warranty**

Gardner Denver backs up every remanufactured airend with a new warranty...18 months from purchase, 12 months from service. Gardner Denver remanufactured airends deliver *quality without question...year in and year out.* Call Gardner Denver for information on the airend exchange program and the name of your authorized distributor.

Phone Number: 800-245-4946 or  
Fax: 901-542-6159

## FOREWORD

Gardner Denver Rotary Screw compressors are the result of advanced engineering and skilled manufacturing. To be assured of receiving maximum service from this machine the owner must exercise care in its operation and maintenance. This book is written to give the operator and maintenance department essential information for day-to-day operation, maintenance and adjustment. Careful adherence to these instructions will result in economical operation and minimum downtime.



### **DANGER**

**Danger is used to indicate the presence of a hazard which will cause severe personal injury, death, or substantial property damage if the warning is ignored.**



### **WARNING**

**Warning is used to indicate the presence of a hazard which can cause severe personal injury, death, or substantial property damage if the warning is ignored.**



### **CAUTION**

**Caution is used to indicate the presence of a hazard which will or can cause minor personal injury or property damage if the warning is ignored.**

### **NOTICE**

**Notice is used to notify people of installation, operation or maintenance information which is important but not hazard-related.**

**This book covers the following models:**

<b>HP (kW)</b>	<b>PSIG (bar)</b>	<b>Air Cooled</b>	<b>Parts List</b>	<b>Control Manual</b>
40 (30)	100, 125, 150, 175 (6.9), (8.6), (10.3), (12.1)	EDE99M	13-8-520	13-8-623
50 (37)	100, 125, 150, 175 (6.9), (8.6), (10.3), (12.1)	EDE99M	13-8-520	13-8-623

## TABLE OF CONTENTS

Maintain Compressor Reliability And Performance With Genuine Gardner Denver Compressor Parts And Support Services .....	ii
Remanufactured Airends .....	ii
Foreword .....	iii
Index .....	v
List Of Illustrations .....	vii
Section 1, General Information.....	1
Section 2, Installation.....	9
Section 3, Starting & Operating Procedures .....	16
Section 4, Controls & Instrumentation .....	19
Section 5, Lubrication. Oil Cooler, Oil Filter & Separator.....	31
Section 6, Air Filter .....	42
Section 7, Belt Drive .....	44
Section 8, Maintenance Schedule.....	46
Section 9, Troubleshooting .....	48

## INDEX

Addition of Oil Between Changes.....	32	General Information, Section 1 .....	1
Air Cooled Unit .....	9	Grounding .....	14
Air Filter		High Temperature Operation .....	32
Section 6.....	16, 42, 46	Inlet Line .....	13
Air Filter Element .....	42	Installation	
Air Flow in Compressor System .....	1	General .....	9
Air Receiver		Installation	
Auxiliary .....	13	Section 2 .....	9
Auxiliary Air Receiver.....	13	Installation for Cold Weather Operation .....	12
Belt Drive		Lifting Unit.....	9
Section 7.....	44	Line, Discharge Service.....	13
Belt Tension		Line, Inlet .....	13
Checking.....	44	Location .....	9
Change Procedure		Lubricant	
Lubricant.....	33	Recommended .....	31
Check		Lubricant Change Procedure .....	33
Daily .....	18	Lubrication	
Checking Belt Tension .....	44	Motor .....	15
Cleaning and Draining Oil System.....	35, 36	Lubrication, Cooling and Sealing .....	1
Cold Ambient Operation.....	32	Lubrication, Oil Cooler, Oil Filter & Separator	
Cold Weather Operation .....	12	Section 5 .....	21, 31, 46
Cold Weather Operation, Installation for.....	12	Maintenance Schedule	
Compression Principle .....	1	Section 8 .....	18, 46
Compressor .....	1	Moisture in the Oil System.....	35
Compressor Oil Cooler .....	38	Moisture Separator/Trap.....	13
Compressor Oil Filter .....	37	Motor Lubrication .....	15
Compressor Oil Separator .....	39	Oil Change Interval .....	35
Compressor Oil System .....	31	Oil Cooler	
Compressor Oil System Check .....	35, 40	Compressor .....	38
Compressor System		Oil Filter	
Air Flow.....	1	Compressor .....	37
Control Piping.....	13	Oil Reservoir .....	38
Controls & Instrucmentation		Oil Reservoir Drain .....	10
Section 4.....	19	Oil Separator	
Cooler		Compressor .....	39
Compressor Oil .....	38	Inspection .....	40
Cooling, Sealing and Lubrication.....	1	Removal for Inspection or Replacement.....	40
Daily Check .....	18	Oil Sight Gauges .....	16, 35
Decals .....	8	Oil Specifications.....	31
Discharge Service Line .....	13	Oil System	
Drain		Compressor .....	31
Oil Reservoir .....	10	Draining and Cleaning .....	35, 36
Draining and Cleaning Oil System.....	35, 36	Oil System Check.....	35, 40
Element		Air and Oil Discharge Temperature .....	40
Air Filter .....	42	Compressor Oil Inlet Temperature .....	40
Enclosure .....	11	Oil Cooler Oil Pressure Differential.....	41
Filter		Oil Cooler Temperature Differential .....	41
Compressor Oil .....	37	Oil Inlet Pressure .....	40
Foundation .....	10	Operation	
Gauges		Cold Ambient.....	32
Oil Sight .....	16, 35	High Temperature.....	32

Piping	
Control .....	13
Pressure Differential Gauging .....	39
Prestart-Up Instructions	
Air Filter .....	16
Electrical .....	16
Enclosure .....	17
Grounding .....	16
Operating Mode .....	17
Piping.....	16
Rotation .....	17
System Pressure .....	17
Recommended Lubricant .....	31
Reservoir	
Oil .....	38
Safety Precautions.....	5
Sealing, Lubrication and Cleaning.....	1
Separator	
Compressor Oil .....	39
Separator/Trap	
Moisture .....	13

Service Check List .....	46
Every 1000 Hours Operation.....	46
Every 125 Hours Operation.....	46
Every 6000 Hours Operation.....	46
Every 8 Hours Operation.....	46
Every Year.....	46
Motor Lubrication .....	46
Oil Separator .....	46
Service Check List	
Air Filter.....	46
Specifications	
Oil .....	31
Starting & Operating Procedures, Section 3....	16
Starting the Unit .....	17
Unit Cold .....	17
Unit Hot .....	18
Stopping the Unit.....	18
Thermal Control (Thermostatic Mixing) Valve	35, 38
Valve	
Thermal Control (Thermostatic Mixing)..	35, 38

## LIST OF ILLUSTRATIONS

Figure 1-1 – Compressor Cycle.....	1
Figure 1-2 – Package – Minimum Pressure/Check Valve, Mixing Valve & Oil Filter .....	2
Figure 1-3 – Package – Oil Level Gauge, Separator & Air Filter .....	3
Figure 1-4 – Package – Controller & Starter Box .....	4
Figure 2-1 – Typical Compressor Room .....	10
Figure 2-2 – Minimum Air Flow.....	10
Figure 2-3 – Cold Weather Installation .....	11
Figure 2-4 – Inlet Line Lengths.....	13
Figure 2-5 – Motor Grease Recommendations (-30°C To 50° C).....	15
Figure 2-6 – Electric Motor Regreasing Interval.....	15
Figure 4-1 – Key Pad .....	19
Figure 4-2- Control Schematic .....	20
Figure 4-3 – Minimum Pressure/Check Valve.....	22
Figure 4-4 – Inlet Valve.....	22
Figure 4-5 – Pressure Chart.....	24
Figure 4-6 – Subtractive Pilot (Closed).....	25
Figure 4-7 – Subtractive Pilot (Opened) .....	25
Figure 4-8 – Maximum Set Points For Auto Sentry RS2000 Controller .....	26
Figure 4-9 – Wiring Diagram – Full Voltage .....	27
Figure 4-10 – Wiring Diagram – Wye Delta .....	29
Figure 5-1 – Flow Diagram – Air/Oil System.....	31
Figure 5-2 – Approximate Oil System Capacities.....	32
Figure 5-3 – Oil Change Interval .....	34
Figure 5-4 – Oil Level Gauge .....	35
Figure 5-5 – Thermostatic Mixing Valve .....	38
Figure 5-6 – Oil Separator.....	39
Figure 6-1 – Heavy Duty Air Filter .....	42
Figure 7-1 – Belt Tension 5VX Belts.....	45

## SECTION 1 GENERAL INFORMATION

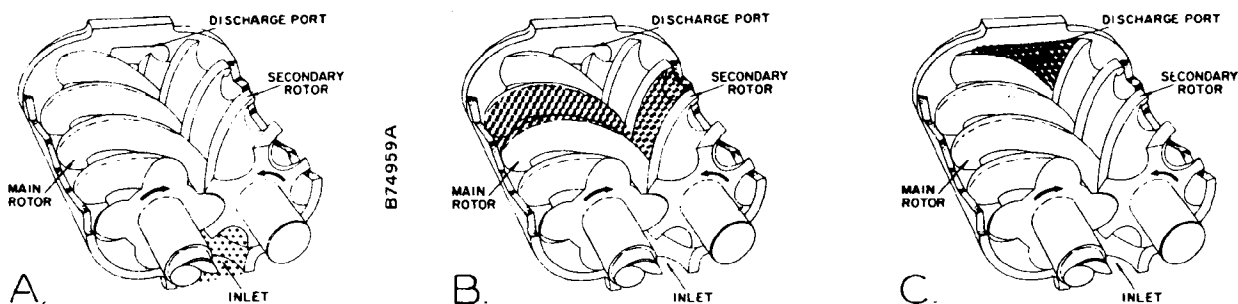

Figure 1-1 – COMPRESSOR CYCLE

**COMPRESSOR** - The Gardner Denver compressor is a single stage, positive displacement rotary machine using meshing helical rotors to effect compression. Both rotors are supported between high capacity roller bearings located outside the compression chamber. Single width cylindrical roller bearings are used at the inlet end of the rotors to carry part of the radial loads. Tapered roller bearings at the discharge end locate each rotor axially and carry all thrust loads and the remainder of the radial loads.

**COMPRESSION PRINCIPLE** (Figure 1-1) - Compression is accomplished by the main and secondary rotors synchronously meshing in a one-piece cylinder. The main rotor has four (4) helical lobes 90° apart. The secondary rotor has six (6) matching helical grooves 60° apart to allow meshing with main rotor lobes.

The air inlet port is located on top of the compressor cylinder near the drive shaft end. The discharge port is near the bottom at the opposite end of the compressor cylinder. *FIGURE 1-1 is an inverted view to show inlet and discharge ports.* The compression cycle begins as the rotors unmesh at the inlet port and air is drawn into the cavity between the main rotor lobes and the secondary rotor grooves (A). When the rotors pass the inlet port cutoff, air is trapped in the interlobe cavity and flows axially with the meshing rotors (B). As meshing continues, more of the main rotor lobe enters the secondary rotor groove, normal volume is reduced and pressure increases.

Oil is injected into the cylinder to remove the heat of compression and seal internal clearances. Volume reduction and pressure increase continues until the air/oil mixture trapped in the interlobe cavity by the rotors passes the discharge port and is released to the oil reservoir (C). Each rotor cavity follows the same “fill-compress-discharge” cycle in rapid succession to produce a discharge air flow that is continuous, smooth and shock free.

**AIR FLOW IN THE COMPRESSOR SYSTEM** (Figure 5-1, page 31) - Air enters the air filter and passes through the inlet unloader valve and on into the compression chamber where oil is injected into the air. After compression, the air/oil mixture passes into the oil reservoir where most of the entrained oil is removed by velocity change and impingement and drops back into the reservoir. The air and remaining oil then passes through the air/oil separator. The air then passes through the minimum pressure/check valve, the aftercooler and the moisture separator and into the plant air lines.

**LUBRICATION, COOLING AND SEALING** - Oil is forced by air pressure from the oil reservoir through the oil cooler, thermostatic mixing valve, and oil filter and discharge into the compressor main oil gallery. A portion of the oil is directed through internal passages to the bearings and shaft oil seal. The balance of the oil is injected directly into the compression chamber to remove heat of compression, seal internal clearances and lubricate the rotors.

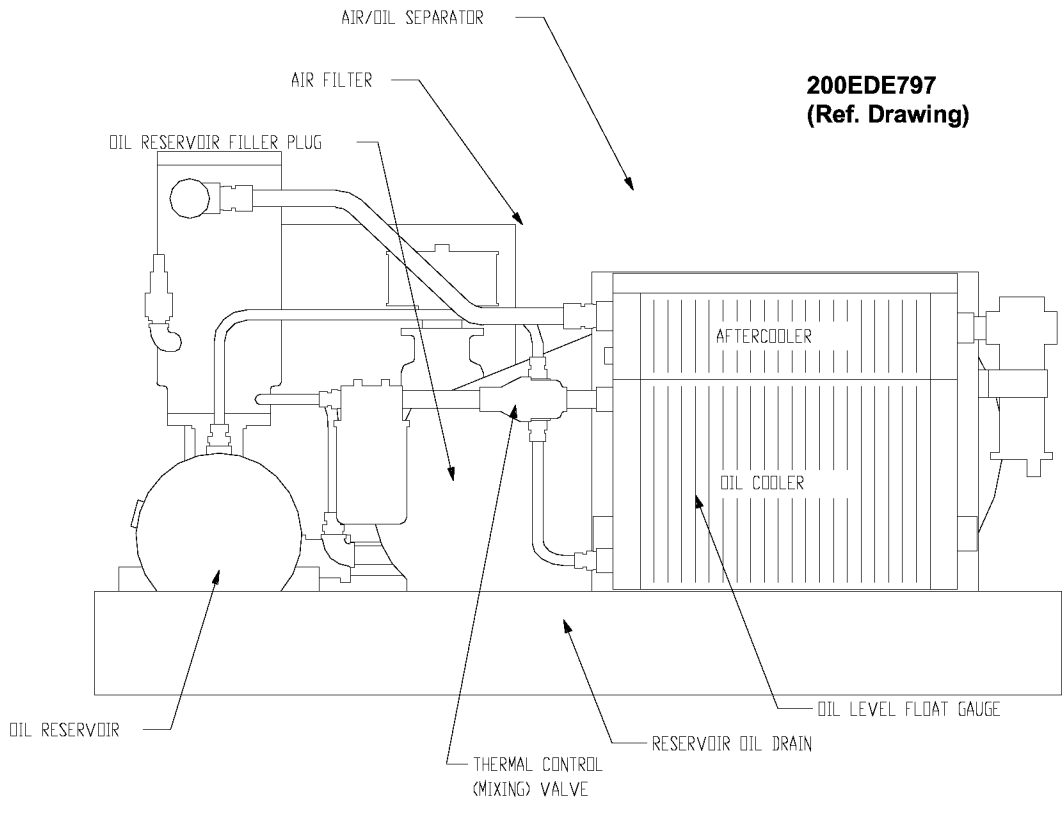

**Figure 1-2 – PACKAGE – MINIMUM PRESSURE/CHECK VALVE, MIXING VALVE & OIL FILTER**

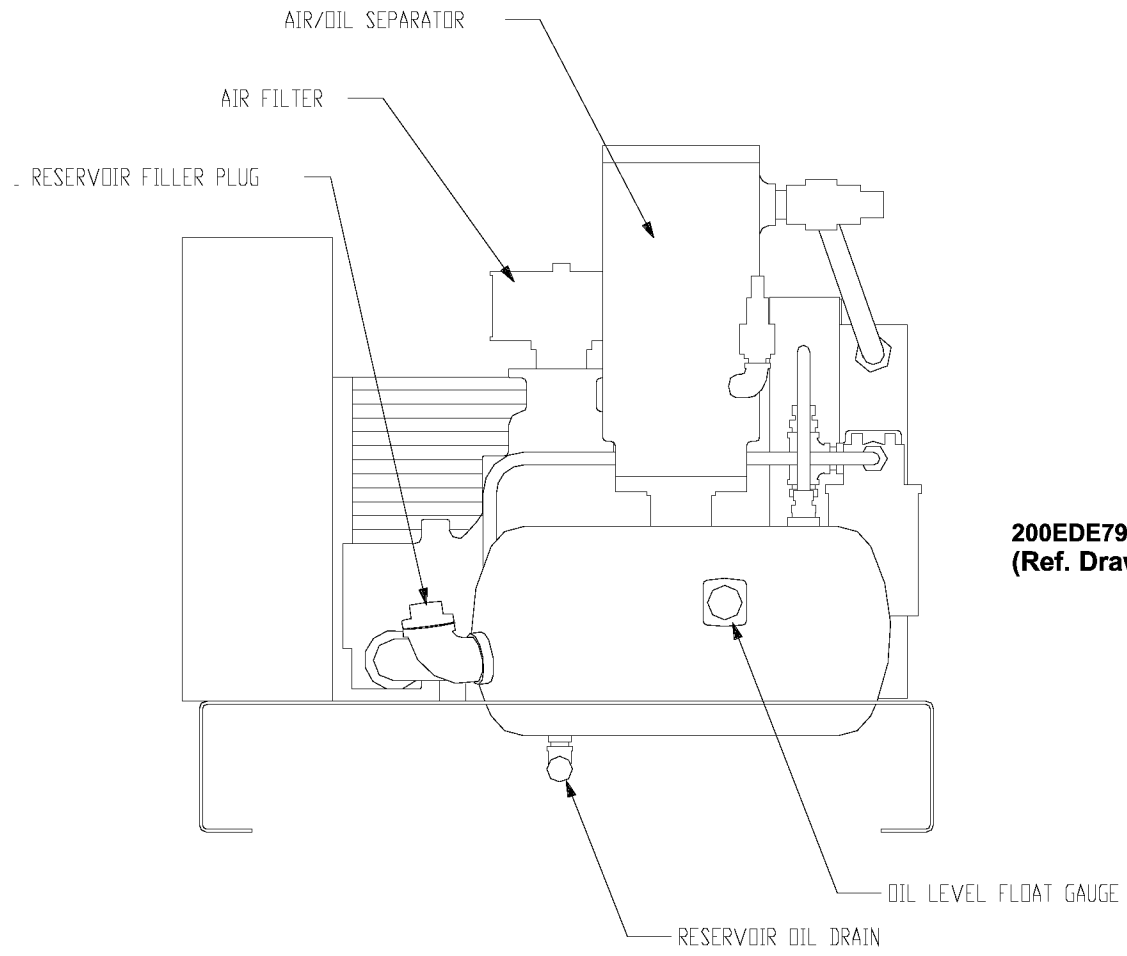

**200EDE797  
(Ref. Drawing)**

**Figure 1-3 – PACKAGE – OIL LEVEL GAUGE, SEPARATOR & AIR FILTER**

**301EDE797-A  
(Ref. Drawing)**

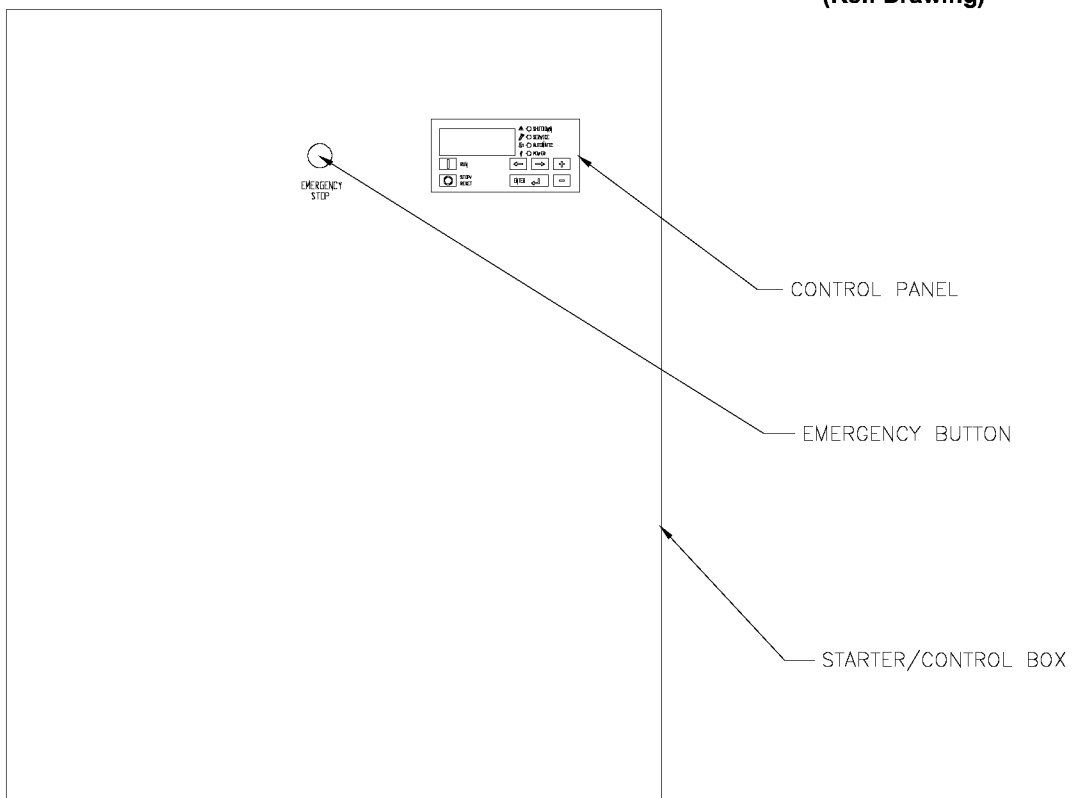

**Figure 1-4 – PACKAGE – CONTROLLER & STARTER BOX**

## SAFETY PRECAUTIONS

Safety is everybody's business and is based on your use of good common sense. All situations or circumstances cannot always be predicted and covered by established rules. Therefore, use your past experience, watch out for safety hazards and be cautious. Some general safety precautions are given below:



### DANGER

**Failure to observe these notices could result in injury to or death of personnel.**

- **Keep fingers and clothing away from revolving fan, drive coupling, etc.**
- **Do not use the air discharge from this unit for breathing – not suitable for human consumption.**
- **Do not loosen or remove the oil filler plug, drain plugs, covers, the thermostatic mixing valve or break any connections, etc., in the compressor air or oil system until the unit is shut down and the air pressure has been relieved.**
- **Electrical shock can and may be fatal.**
- **Compressor unit must be grounded in accordance with the National Electrical Code. A ground jumper equal to the size of the equipment ground conductor must be used to connect the compressor motor base to the unit base.**
- **Fan motors must remain grounded to the main base through the starter mounting panel in accordance with the National Electrical Code.**
- **Open the main disconnect switch, tag and lockout before working on the control.**
- **Disconnect the compressor unit from its power source, tag and lockout before working on the unit – this machine is automatically controlled and may start at any time.**



## WARNING

Failure to observe these notices could result in damage to equipment.

- **Stop the unit** if any repairs or adjustments on or around the compressor are required.
- **Disconnect the compressor** unit from its power source, tag and lockout before working on the unit – this machine is automatically controlled and may start at any time.
- **An Excess Flow Valve** should be on all compressed air supply hoses, exceeding 1/2 inch inside diameter. (OSHA Regulation, Section 1926.302, or local regulations)
- **Do not exceed the rated maximum pressure values** shown on the nameplate.
- **Do not operate unit** if safety devices are not operating properly. Check periodically. Never bypass safety devices.

DECALS

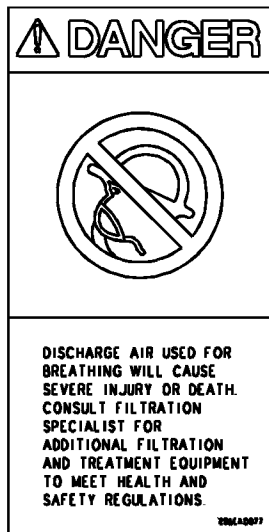

206EAQ077

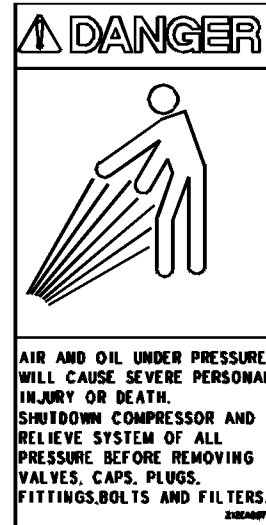

212EAQ077

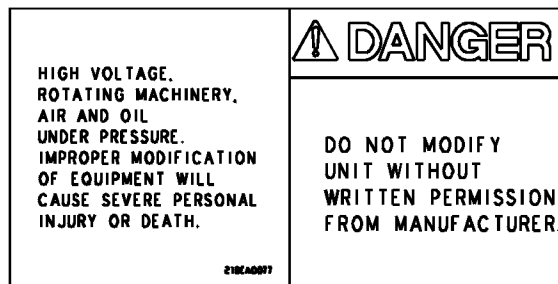

218EAQ077

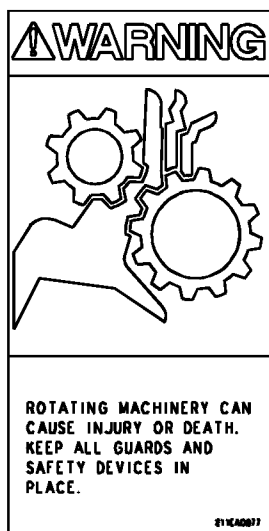

211EAQ077

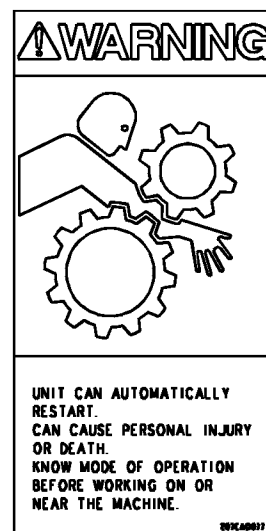

207EAQ077

DECALS

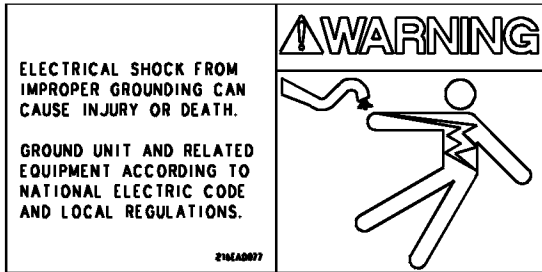

216EAQ077

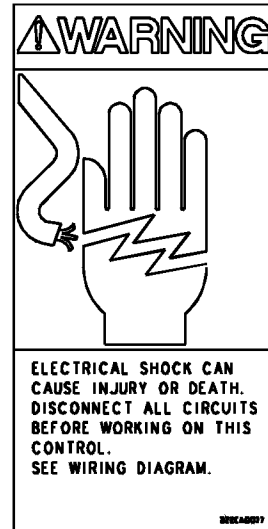

222EAQ077

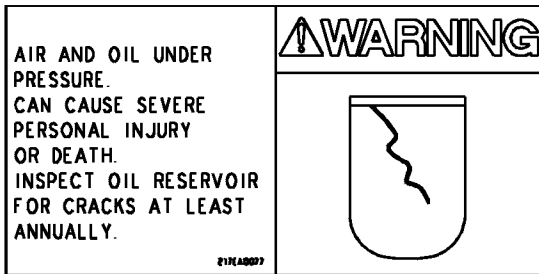

217EAQ077

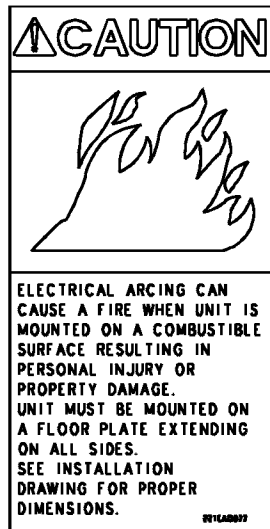

221EAQ077

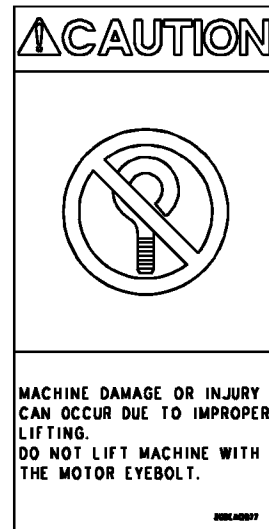

208EAQ077

## SECTION 2 INSTALLATION

---

**GENERAL** - On receipt of the unit, check for any damage that may have been incurred during transit. Report any damage or missing parts as soon as possible.



### CAUTION

**Do not electric weld on the compressor or base; bearings can be damaged by passage of current.**

**LIFTING UNIT** - Proper lifting and/or transporting methods must be used to prevent damage. Lifting slots are provided in the base for tow motor use. The unit may also be moved into location by rolling on bars.



### CAUTION

**Lift compressor unit by base only. Do not use other places such as motor, compressor or discharge manifold piping as lifting points.**



### DANGER

**The eyebolts or lugs provided on the motor are for lifting the motor only and should not be used to lift any additional weight. All eyebolts must be securely tightened. When lifting the motor, the lifting angle must not exceed 15 degrees. Failure to observe this warning may result in damage to equipment or personal injury.**



### DANGER

**Compressor, air/oil reservoir, separation chamber and all piping and tubing may be at high temperature during and after operation.**

**Location** (Figure 2-1, page 10) - The compressor should be installed where it is protected from rain, snow and freezing temperatures, in a clean, well-lighted, well-ventilated area with ample space all around for maintenance. Select a location that provides a cool, clean, dry source of air. In some cases it may be necessary to install the air filter at some distance from the compressor to obtain proper air supply.

**Air-Cooled Unit** - A combination oil/aftercooler is supplied as standard equipment on all air-cooled units. The air-cooled unit with the standard enclosure requires sufficient flow for the compressor oil/aftercooling system and electric motor cooling (Figure 2-2, page 10). Air is drawn into the unit at the motor side of the enclosure and is exhausted at the cooler side. Do not block the air flow to and from the unit. Allow three and one half (3-1/2) feet (1.1M) to the nearest obstruction on the starter end and control box end of the unit. Allow two (2) feet (.6M) to the nearest obstruction above and on other sides of unit. For continuous efficiency, oil cooler cores must be periodically cleaned with either vacuum or compressed air. If wet cleaning is required, shield motor and spray on a mild soap solution and flush with clean water.



## WARNING

**For aluminum oil coolers, do not use any cleaning solution that is not compatible with aluminum. Use of improper solution may result in damage to the cooler.**

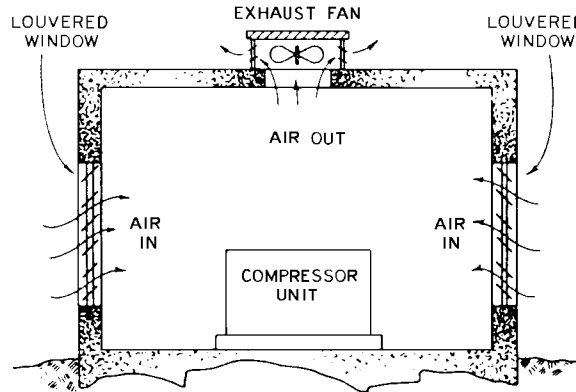

A75119

**Figure 2-1 – TYPICAL COMPRESSOR ROOM**

Minimum Air Flow* for Compressor and Cooling Cubic Feet/Minute (Cubic Meters/Minute)	
Air Cooled	
All Models	6500 cfm (184 M <sup>3</sup> /min.)

\* 80° F (27° C) Inlet Air

**Figure 2-2 – MINIMUM AIR FLOW**

**FOUNDATION** - Rotary screw compressors require no special foundation, but should be mounted on a smooth, solid surface. Whenever possible install the unit near level. Temporary installation may be made at a maximum 10° angle lengthwise or 10° sidewise. Mounting bolts are not normally required. However, installation conditions such as piping rigidity, angle of tilt, or danger of shifting from outside vibration or moving vehicles may require the use of mounting bolts and shims to provide uniform support for the base. Belt alignment and tension should be checked after installation. (For information on Belt Alignment and Tension see Section 7, page 44.)

**OIL RESERVOIR DRAIN** - The oil drain is piped from the bottom of the reservoir to the side of the frame. This drain is approximately 2 inches (50 mm) above the floor level. If this is not sufficient to conveniently drain the oil, some other methods of providing drain are:

1. Elevate the compressor unit on a suitable structure to obtain the desired drain height.



## CAUTION

If the compressor unit base is raised above floor level, the space between the floor and the base bottom must be closed with solid material all around to prevent re-circulation of hot air from the oil cooler end and over temperature operation.

2. Construct an oil sump or trough below the floor level and pump or bail the drained oil.
3. Pump oil from the reservoir filler opening or drain to a container.

**ENCLOSURE** - The compressor, electric motor, oil cooler and aftercooler are mounted inside the enclosure. Service doors are provided for maintenance access. Be sure to allow enough space around the unit for the doors to be removed.

Any of the enclosure doors may be removed by opening the door and lifting it up slightly to disengage the hinges.

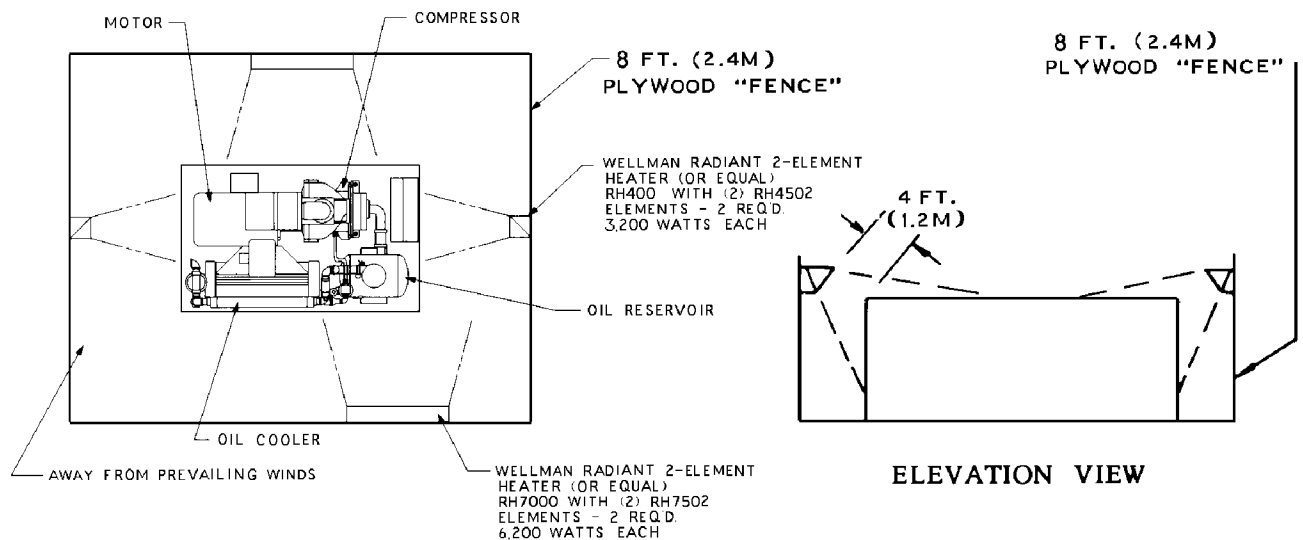

Figure 2-3 – COLD WEATHER INSTALLATION



## DANGER

Do not operate the compressor with the fan and belt guard removed. Exposed fan and belts may cause injury to personnel.

The motor inspection/air filter service panel is held by two latches and lifts away from the enclosure. The air outlet panel is attached by screws to the enclosure and is not readily removable.

**INSTALLATION FOR COLD WEATHER OPERATION** (Figure 2-3, page 11) - It is recommended that the unit be installed inside a shelter that will be heated to temperatures above freezing (32° F, 0° C). This will eliminate many of the problems associated with operating units in cold climates, such as freezing in control lines and downstream of the cooler.

Refer to Engineering Data Sheet 13-9-411 for the advantages of using the heat recovered from rotary compressors. This heat recovery could easily pay for an adequate shelter for the unit.

When an outside installation must be made, the precautions required will depend on the severity of the environment. The following are general guidelines for outside installations:

	<b>WARNING</b>
<b>Failure to remove condensate from an idle cooler in freezing temperatures will cause permanent cooler damage. Drain condensate after system shutdown. It is the owner/operator's responsibility to ensure that condensate has been drained and cooler dried out to prevent cooler damage.</b>	

#### **Cold Weather** (Down To +10° F, -12° C)

1. Be sure all drains, traps, and control lines, including pressure transducer lines are heated to avoid freezing of condensate. Heat tape with thermostat control is generally satisfactory for this purpose and can be obtained at various local plumbing or hardware outlets at nominal cost.
2. If an air-cooled aftercooler is to be used, provisions to bypass the aftercooler must be made. Since cold air contains very little moisture, successful operation can be achieved without the aftercooler.
3. Provide at least some simple shelter such as a plywood windbreak to protect against drifting snow.
4. Use only Gardner Denver AEON 9000SP lubricant.
5. Monitor unit carefully during start-up and operation to be sure it is functioning normally.
6. Specify NEMA 4 enclosure for electrical devices.

#### **Extreme Cold Weather Operation** (Down To -40° F, -40° C)

In addition to the above, the following should be provided:

1. It will be necessary to provide shutters or to block off part of the cooler in some manner since the cooler is greatly oversized for operation in these low temperatures. Since shutters are not provided as a factory option, blocking off a portion of the cooler with plywood should be satisfactory.
2. In extreme environments, run the unit in "Constant Speed" only.
3. Some means of providing heat during shutdown should be provided. There are various methods to accomplish this, but since openings are not provided for sump heaters, the use of radiant heaters is recommended. The heaters should be sized to provide at least a +10° F (-12° C) environment for coolers, motor and sump. Figure 2-3, page 11, this section, shows how these might be located in a typical installation and sizes required.

Remember unsheltered (outside) installations should be avoided where possible. Installation next to a heated building where enough heat can be used to keep the compressor room above freezing will save many complications in the operation and installation of the unit.

Refer to Engineering Data Sheet 13-9-411, available from an authorized Gardner Denver distributor, for the advantages of using the heat recovered from rotary compressors. This heat recovery could easily pay for an adequate shelter for the unit.

**AUXILIARY AIR RECEIVER** - An auxiliary air receiver is not required if the piping system is large and provides sufficient storage capacity to prevent rapid cycling. When used, an air receiver should be of adequate size, provided with a relief valve of proper setting, a pressure gauge and a means of draining condensate.

**MOISTURE SEPARATOR/TRAP** - Since the unit is equipped with a built-in aftercooler, a combination moisture separator and trap is furnished with the unit. A means of draining condensate will need to be provided for.

**CONTROL PIPING** - Control piping is not necessary since the rotary screw compressor unit is factory wired and piped for the control system specified.

**INLET LINE** - Where an inlet line is used between the air filter and the compressor, it must be thoroughly cleaned on the inside to prevent dirt or scale from entering the compressor. **If welded construction is used, the line must be shot blasted and cleaned to remove welding scale.** In either case, the inlet line must be coated internally by galvanizing or painting with a moisture and oil-proof sealing lacquer. Up to ten (10) feet (3 meters) in length, the inlet line should be the full size of the inlet opening on the compressor. If an extra-long line is necessary, the pipe size should be increased according to Inlet Line Length Chart, Figure 2-4.

Accessibility for inlet air filter servicing must be considered when relocating the filters from the unit to a remote location.

Length of Inlet Line	Diameter of Pipe Size
0 to 10 Feet (0 to 3 Meters)	Same as Compressor Inlet Opening
10 to 17 Feet (3 to 5 Meters)	One Size Larger than Inlet Opening
17 to 38 Feet (5 to 11.5 Meters)	Two Sizes Larger than Inlet Opening

**Figure 2-4 – INLET LINE LENGTHS**

**DISCHARGE SERVICE LINE** - The discharge service line connection is made at the upper right hand corner of the cooler, viewed from the oil cooler side. A hand operated valve, (air service valve) must be installed between the unit and the customer's air system. When manifolding two or more rotary screw compressor units on the same line, each unit is isolated by the check valve in the unit discharge line. If a rotary screw compressor is manifolded to another compressor, be sure the other compressor has a check valve in the line between the machine and the manifold. If a rotary screw and a reciprocating compressor are manifolded together, an air receiver must be located between the two units.



## DANGER

**Discharge air used for breathing will cause severe injury or death. Consult filtration specialists for additional filtration and treatment equipment to meet health and safety standards.**

**BLOWDOWN VALVE PIPING** - The blowdown valve is fitted with a muffler for operation indoors. If the installation requires, the muffler may be removed and the blowdown valve piped to the outside with a pipe size the same as the blowdown valve outlet connection.

### ELECTRICAL WIRING



## WARNING

**Electrical shock can cause injury or death. Open main disconnect switch, tag and lockout before working on starter/control box.**

**Standard Units** - The rotary screw compressor is factory wired for all starter to motor and control connections for the voltage specified on the order. It is necessary only to connect the unit starter to the correct power supply. The standard unit is supplied with an open drip-proof motor, a NEMA 12 starter and control enclosure. See "Location" paragraph, page 9, for distance to nearest obstruction on starter and control box sides of the unit.

The overload heaters are to be selected according to starter manufacturer's tables, which are attached to the inside of the control box, based on motor nameplate full load amperage.

**GROUNDING** - Equipment must be grounded in accordance with Section 250 of the National Electrical Code.



## WARNING

**Failure to properly ground the compressor package could result in controller malfunction.**

**MOTOR LUBRICATION** - Long time satisfactory operation of an electric motor depends in large measure on proper lubrication of the bearings. The following charts show recommended grease qualities and regreasing intervals for ball bearing motors. For additional information refer to the motor manufacturer's instructions. The following procedure should be used in regreasing:

1. Stop the unit.
2. Disconnect, tag and lockout the unit from the power supply.
3. Remove the relief plug and free hole of hardened grease.
4. Wipe lubrication fitting clean and add grease with a hand-operated grease gun.
5. Leave the relief plug temporarily off. Reconnect unit and run for about 20 minutes to expel the excess grease.
6. Stop the unit. Replace the relief plug.
7. Restart the unit.

 <b>WARNING</b>
<b>Rotating machinery can cause injury or death. Open main disconnect switch, tag and lockout before working on starter/control box.</b>

MANUFACTURER	TRADE NAME
CHEVRON	SRI #2
SHELL	DOLIUM R
EXXON	UNIREX #2
EXXON	POLYREX

**Figure 2-5 – MOTOR GREASE RECOMMENDATIONS (-30°C to 50° C)**

Type of Service	Typical Examples	Rating	Relubrication Interval
Standard	One or Two Shift Operation	150 HP (112 kW) & Below	18 Months
Severe	Continuous Operation	150 HP (112 kW) & Below	9 Months
Very severe	Dirty Locations, High Ambient Temperature	150 HP (112 kW) & Below	4 Months

**Figure 2-6 – ELECTRIC MOTOR REGREASING INTERVAL**

## SECTION 3

### Starting & Operating Procedures

---

**PRESTART-UP INSTRUCTIONS** - A new unit as received from the factory has been prepared for shipping only. Do not attempt to operate the unit until checked and serviced as follows:

1. **Compressor Oil** - Check oil level in the reservoir. Add oil only if the oil level gauge reads in the red "ADD OIL" range. Do not mix different type oils. Unit is shipped filled with Gardner Denver AEON 4000 Lubricating Coolant which is suitable for the first 4000 hours under normal operating conditions. (AEON 4000 is generally suitable for use up to 4000 hours service life, provided the lubricant is monitored by periodic analysis.)

#### REPLACE OIL FILTER EVERY 1000 HOURS

Initial fill, or filling after a complete draining of the system, may show the oil level above the center of the green range on the gauge. After start-up, the oil level will drop and fluctuate as the machine runs. To check for proper oil level, see "OIL LEVEL GAUGE", SECTION 5, page 35.

#### NOTICE

**Regular maintenance and replacement at required intervals of the oil filter, air filter and air/oil separator is necessary to achieve maximum service and extended drain intervals of AEON 4000 petroleum base lubricant. Use only genuine Gardner Denver filters designed and specified for this compressor.**



#### DANGER

**Before removing the oil filler plug, always stop the unit and release air pressure, tag and lockout the power supply to the starter. Failure to release pressure or properly disconnect the power may result in personal injury or death.**

During unloaded operation and after shutdown, the system will partially drain back into the oil reservoir and the oil level may read higher than when operating on load. DO NOT DRAIN OIL TO CORRECT; on the next loaded cycle or start, oil will again fill the system and the gauge will indicate the operating level

2. **Air Filter** - Inspect the air filter to be sure it is clean and tightly assembled. Refer to SECTION 6. "Air Filter, page 42, complete servicing instructions. Be sure the inlet line, if used, is tight and clean.
3. **Piping** - Refer to SECTION 2, "Installation", page 9, and make sure piping meets all recommendations.
4. **Electrical** - Check the wiring diagrams furnished with the unit to be sure it is properly wired. See Figure 4-9, page 27 and Figure 4-10, page 29, for general wiring diagrams and SECTION 2, page 9 for installation instructions.
5. **Grounding** - The unit must be properly grounded according to Section 250 of the National Electrical Code.



## WARNING

**Failure to properly ground the compressor package could result in controller malfunction.**

6. **Rotation** - Check for correct motor rotation using "JOG MODE." Compressor drive shaft rotation must be clockwise standing facing the compressor sheave. See Control Manual 13-8-623, page 11.



## WARNING

**Operation with incorrect motor rotation can damage equipment and cause oil eruption from the compressor inlet. When checking motor rotation, induce minimum rotation (less than one revolution if possible). Never allow motor to reach full speed.**

7. **System Pressure** - Set the controls to the desired load pressure. DO NOT EXCEED THE MAXIMUM OPERATING PRESSURE ON THE COMPRESSOR NAMEPLATE. See Control Manual 13-8-623, page 8, "Programming the Load-Unload Pressure Set points," for procedure.



## WARNING

**Operation at excessive discharge air pressure can cause personal injury or damage to equipment. Do not adjust the full discharge air pressure above the maximum stamped on the unit nameplate.**

8. **Operating Mode** - Refer to Control Manual 13-8-623, for detailed information on the control system.
9. **Enclosure** - Check for damaged panels or doors. Check all screws and latches for tightness. Be sure doors are closed and latched.

**STARTING THE UNIT** - Observe the following starting procedures:

### Unit Cold:

1. Close the air service valve (customer furnished) between the main air system and the check valve on the package.
2. Turn on power to the compressor package. To start, press "STOP/RESET", then press "RUN".
3. Run for approximately five minutes or until the temperature stabilizes and then open the air service valve.

The unit is equipped with a minimum (65 psig, 4.5 Bars) pressure/check valve; no special procedure to maintain the unit reservoir pressure is required.

**Unit Hot** (No warm-up period is required):

1. Close the air service valve (customer furnished) between the main air system and the check valve on the package.
2. Turn on power to the compressor package. To start, press "STOP/RESET", then press "RUN".
3. Run for approximately one minute and then open the air service valve.

The unit is equipped with a minimum (65 psig, 4.5 Bars) pressure/check valve, no special procedure to maintain the unit reservoir pressure is required.

**DAILY CHECK** - Refer to SECTION 8, "Maintenance Schedule", page 46 .

**STOPPING THE UNIT:**

1. To stop compressor operation, press "STOP/RESET".
2. Wait approximately one minute to allow the compressor to stop.

The oil reservoir will automatically blow down as the motor stops.

## SECTION 4 CONTROLS & INSTRUMENTATION

### GENERAL DESCRIPTION

The Gardner Denver rotary screw compressor is prewired with all controls, motor, and starter for the voltage and horsepower at the time of ordering. It is necessary only to connect the compressor unit to the correct power supply and to the shop air line. A standard compressor unit consists of the compressor, oil reservoir, oil cooling system and filter, motor type as specified, NEMA 12 starter / control box, and control components as described below. Inlet valve modulation is standard.

### **AUTO SENTRY® OPERATION**

Operation of the "AUTO SENTRY®" is dependent on selection of an operating mode from the controller keypad. Prior to starting, the STOP/RESET key must be pressed to place the controller into its READY state (as indicated on the display). Compressor operation may then be started by pressing the RUN key. While in any operating mode, the display will indicate the mode, and the operating light will be on.

Press the STOP/RESET key at any time to stop the compressor under normal conditions.

AUTOMATIC is the most common selected mode of operation, as it automatically will operate the compressor unit in the most efficient manner for the demand of the air system. Refer to the controller manual for descriptions of other modes.

 <b>WARNING</b>
<b>Automatic restarting or electrical shock can cause injury or death. Open and lock main disconnect and any other circuits before servicing unit.</b>

### **CONTROL DEVICES**

**Controller** - This compressor unit features the "AUTO SENTRY" controller, which integrates all the control functions under microprocessor control. Its functions include safety and shutdown, compressor regulation, operator control, and advisory/maintenance indicators. The keypad and display provide the operator with a logical and easily operated control of the compressor and indication of its condition. The controller is factory adjusted for the compressor package, but allows tuning for specific applications.

Detailed instructions for the controller are found in the "Auto Sentry" Controller Operating and Service Manual 13-8-623.



**Figure 4-1 – KEY PAD**

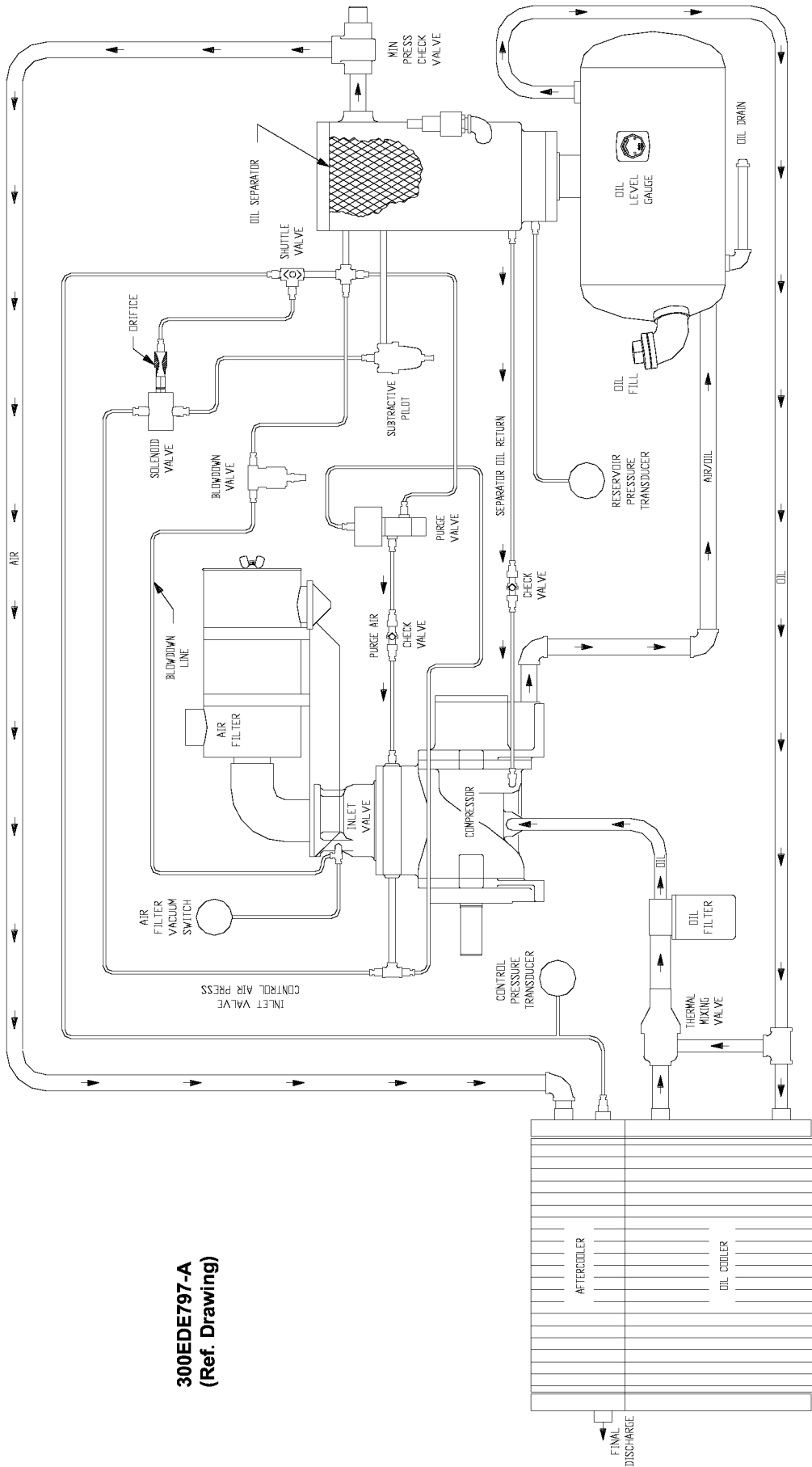

300EDE797-A  
(Ref. Drawing)

Figure 4-2- CONTROL SCHEMATIC

**Relief Valve** - A pressure relief valve(s) is (are) installed in the final discharge line and set at the factory for protection against overpressure. Periodic checks should be made to ensure it is operating properly.

The relief valve should be tested for proper operation at least once every year. To test the relief valve, raise the system operating pressure to 75% of the relief valve set pressure and manually open the valve with the hand lever. Hold the valve open for a few seconds and allow it to snap shut.



## WARNING

**When the relief valve opens, a stream of high velocity air is released, resulting in a high noise level and possible discharge of accumulated dirt or other debris. Always wear eye and ear protection and stand clear of the discharge port when testing the relief valve to prevent injury.**



## CAUTION

**Never paint, lubricate or alter a relief valve. Do not plug vent or restrict discharge.**



## WARNING

**Operation of the unit with improper relief valve setting can result in severe personal injury or machine damage. Ensure properly set valves are installed and maintained.**

**Oil Level Gauge** - This gauge is located on the oil reservoir and indicates the oil level. See "Oil Level Gauge", SECTION 5, page 35, for how to read oil level.

**Minimum Discharge Pressure/Check Valve** (Figure 4-3, page 22) - An internal spring-loaded minimum pressure valve is used in the final discharge line to provide a positive pressure on the oil system even when the air service valve is fully open. The valve senses upstream pressure. If demand for air exceeds the compressor capacity, the valve throttles the flow to maintain a minimum pressure on the upstream (oil reservoir) side of the valve. When pressure rises above the minimum pressure (standard setting 60 to 65 PSIG, 4.1 to 4.5 bar), the valve reaches the full open position.

A check valve incorporated in the minimum pressure valve prevents back-flow of air from the shop air line when the unit stops, unloads or is shut down.

The valve does not require maintenance or adjustment. If the valve fails to function, it must be replaced because it is not field adjustable or field repairable.

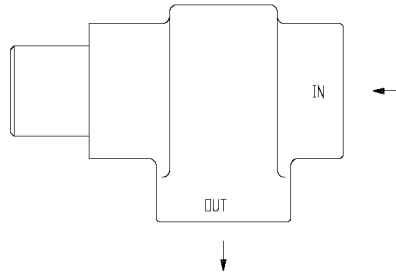

**Figure 4-3 – MINIMUM PRESSURE/CHECK VALVE**

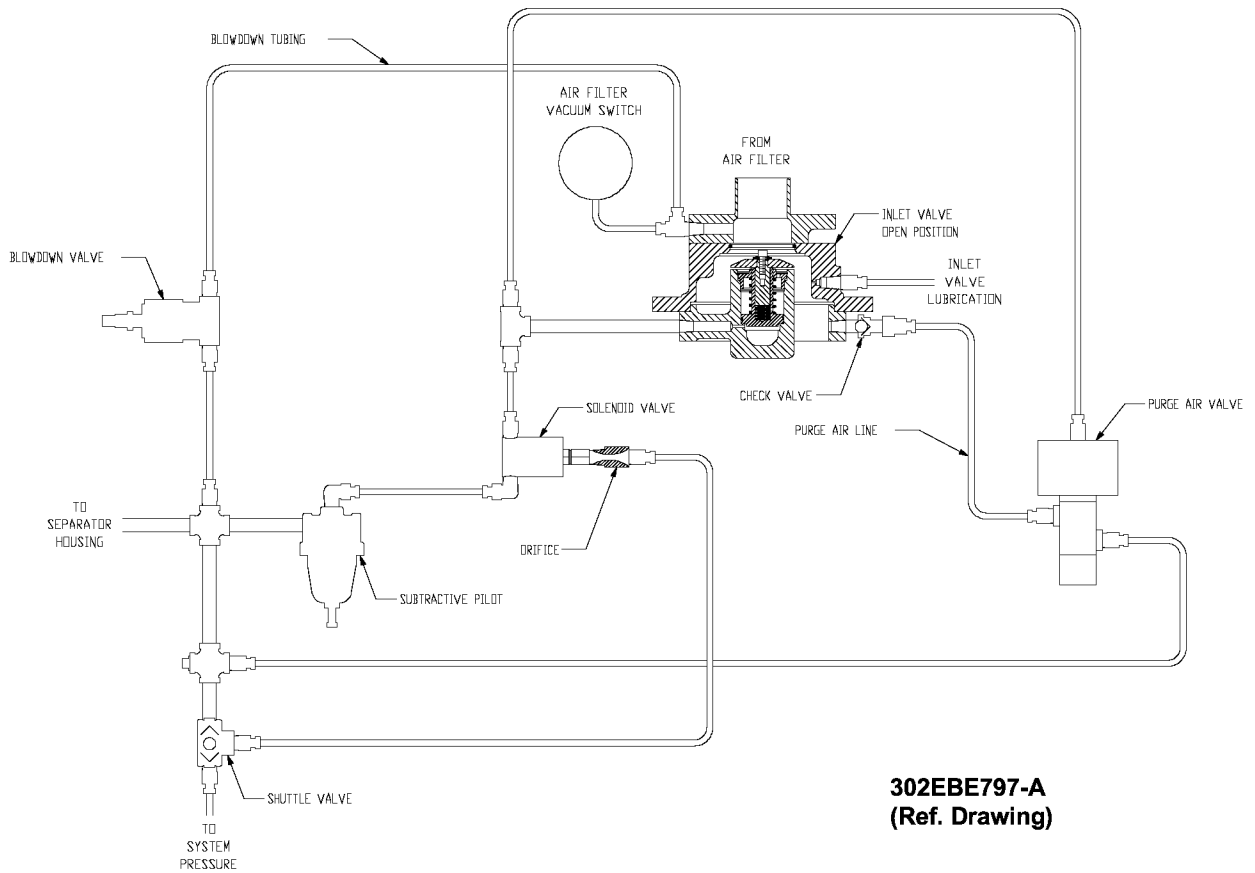

**Figure 4-4 – INLET VALVE**

**Inlet Valve** (Figure 4-4, page 22) - The inlet valve is a pilot—actuated valve that restricts the inlet to control capacity and closes to unload the compressor. At shutdown the inlet valve closes to function as a check valve and prevent back flow of air.

As control pressure is increased the valve will begin to close, restricting the inlet and reducing compressor capacity. Approximately 18 psig (1.2 bar) of control pressure is required to close the inlet valve completely. When closed, the inlet valve prevents the flow of air in either direction. With standard modulating control feature: when the control pressure is less than 18 psig (1.2 bar), the inlet valve will modulate to match compressor capacity to system demand.

**Blowdown Valve** (Figure 4-4, page 22) - The blowdown valve is a two-way solenoid valve which is piped into the oil separator outlet ahead of the check valve. When the solenoid is de-energized, the blowdown valve opens and the oil system is blown down. When the solenoid is energized, the blowdown valve closes and allows the oil system to pressurize.

**System Pressure Transducer** (Figure 4-2, page 20) - This transducer is connected after the minimum pressure valve. It converts the pressure in the plant air system into an electrical signal for use by the "AUTO SENTRY" controller for modulation and control.

**Reservoir Pressure Transducer** (Figure 4-2, page 20) - This transducer is connected to the coolant system. Its signal is used to prevent loaded starts, monitor oil pressure, and to monitor the condition of the separator.

**Air Filter Vacuum Switch** (Figure 4-4, page 22) - This switch is used to monitor air filter condition and alert the user if the filter requires service or replacement.

**Purge Air Valve** – The purge valve is a normally closed two-way air actuated valve that admits purge air from the final discharge manifold to the compressor to counteract the oil knock that occurs in oil-flooded rotary screw compressors when they are completely unloaded with pressure in the oil reservoir. This valve is controlled by the same control pressure which controls the inlet valve.

**Subtractive Pilot** – Used to control the inlet valve for modulation. See page 24 for more detail.



## CAUTION

**Machine damage will occur if compressor is repeatedly restarted after any one of the shutdown modes stops operation of the unit. Find and correct the malfunction before resuming operation.**

**Discharge Thermistor** - This sensor is located directly in the compressor discharge. Its signal is used to monitor compressor temperature and shut down the compressor if a coolant problem is detected.

**Reservoir Thermistor** - This sensor is located in the reservoir/separator housing and is used to monitor temperature and shut down the compressor if temperature problems occur at the separator.

**Emergency Stop Pushbutton** - This is a maintained pushbutton, and removes power from the controller outputs regardless of controller status. It is located on the upper section of the control box door, next to the keypad. This should be used for emergency purposes only - use the keypad [STOP/RESET] for normal controlled stopping.

 <b style="font-size: 1.2em; margin-left: 10px;">WARNING</b>
<p><b>Automatic restarting or electrical shock can cause injury or death. Open and lock main disconnect and any other circuits before servicing unit.</b></p>

 <b style="font-size: 1.2em; margin-left: 10px;">DANGER</b>
<p><b>Air/oil pressure will cause severe personal injury or death. Shut down compressor, relieve system of all pressure, disconnect, tag and lockout power supply to the starter before removing valves, caps, plugs, fittings, bolts and filters.</b></p>

**Control Transformer** - This changes the incoming power voltage to 110-120 volts for use by all unit control devices. Two primary and one secondary fuse are provided. Refer to adjacent labeling for replacement information.

**Terminal Strip** - This provides connections for all 110-120 volt devices not contained within the enclosure.

**Main Starter** - This starter is used to provide control and overload protection for the main drive motor.

Standard full voltage starters employ a single contactor and overload protection for each motor. Overload heaters should be selected and adjusted based on the motor nameplate amps and the instructions located inside the control box door.

**Subtractive Pilot (Modulating Feature)** - The subtractive pilot is an adjustable, spring-loaded diaphragm valve that controls pressure in relation to the upstream (discharge) pressure

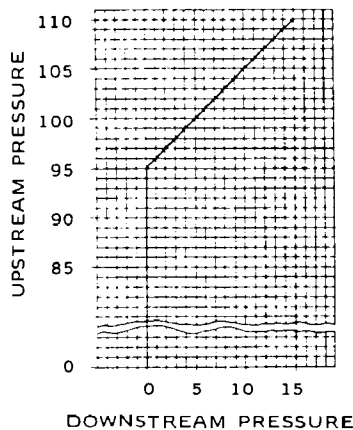

**Figure 4-5 – PRESSURE CHART**

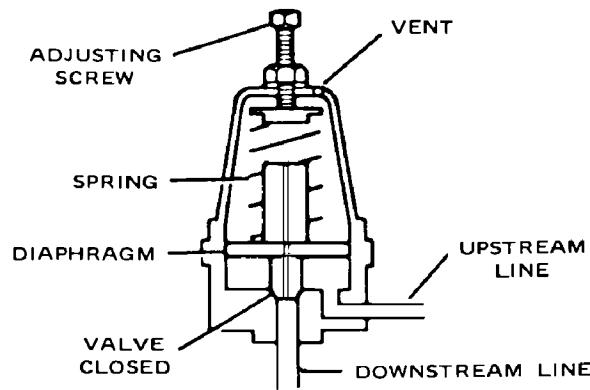

**Figure 4-6 – SUBTRACTIVE PILOT (CLOSED)**

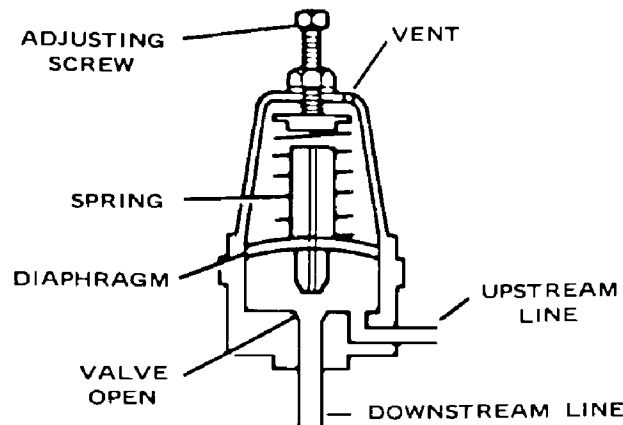

**Figure 4-7 – SUBTRACTIVE PILOT (OPENED)**

The downstream pressure is maintained equal to the upstream pressure minus a constant which is adjustable. In the example shown in Figure 4-5, page 24, the downstream pressure equals the upstream pressure minus 95 psi (6.6 bar). When the upstream pressure rises to 100 psig (6.9 bar), the downstream pressure rises to 5 psig (.3 bar). This 1 to 1 psi (bar) rise is constant above the set point.

Below the set point, the valve seat is closed and the downstream pressure is vented. In the example of Figure 4-5, page 24, downstream pressure is vented below 95 psig (6.6 bar)

Figure 4-6, shows a schematic cross section of the subtractive pilot with the valve seat closed and downstream line vented.

Figure 4-7, shows the pilot with valve seat open, holding a downstream pressure which is adjustable with the screw. In this position it is normal for the valve to continually bleed air through the small vent hole in the bowl.

Moisture, oil and dirt in the control system lines and components can cause the set point of the subtractive pilot to shift or be erratic. The subtractive pilot can be disassembled and the diaphragm and ports cleaned when necessary.

**Operating Air Pressure Adjustment** – The “Auto Sentry” controller load and unload pressure set points should already be programmed. See Control Manual 13-8-623, page 8.

 <b>WARNING</b>
<p><b>Operation at excessive discharge air pressure can cause personal injury or damage to equipment. Do not set unload pressure above the maximum stamped on the unit nameplate.</b></p>

To adjust the subtractive pilot:

1. With the unit off, loosen the locknut and back out the adjusting screw several turns so the subtractive pilot will fully unload the compressor before the unload pressure set point of the microprocessor controller is reached.
2. Close the air service valve and start the unit in the “RUN” mode. Allow unit to reach the pressure at which the subtractive pilot fully unloads the compressor.
3. Turn-in the adjusting screw until the unload pressure set point is reached and the microprocessor controller allows the unit to blow down.
4. Turn-in the adjusting screw and additional one eighth (1/8) turn and tighten the locknut. As a result, the subtractive pilot will not fully unload the compressor before the microprocessor controller's unload pressure set point is reached.
5. Using the air service valve, cycle the unit between load and unload several times to be certain that the unit will reach the microprocessor controller's unload pressure set point and blow down.

<b>NAMEPLATE FULL LOAD OPERATING PRESSURE</b>	<b>CONTROL SYSTEM PRESSURE</b>	
	<b>LOAD</b>	<b>UNLOAD</b>
100 PSIG (6.9 bar)	100 PSIG (6.9 bar)	108 PSIG (7.5 bar)
125 PSIG (8.6 bar)	125 PSIG (8.6 bar)	133 PSIG (9.2 bar)
150 PSIG (10.4 bar)	150 PSIG (10.4 bar)	158 PSIG (10.9 bar)
175 PSIG (12.1 bar)	167 PSIG (11.5 bar)	175 PSIG (12.1 bar)

**Figure 4-8 – MAXIMUM SET POINTS FOR AUTO SENTRY RS2000 CONTROLLER**

<b>NOTICE</b>
<p><b>Load set point cannot be set within 8 psi (.6 bar) of the unload set point. Minimum operating pressure is 60 to 65 psig (4.1 to 4.5 bar)</b></p>

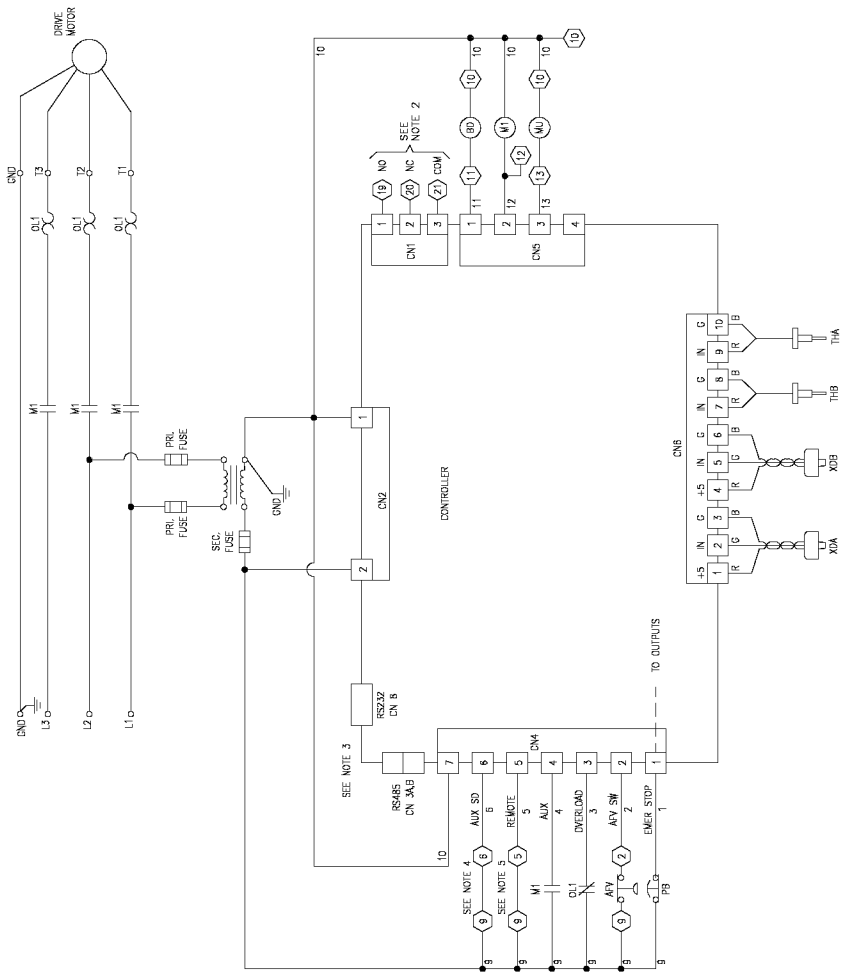

- LEGEND:
- AVY - AIR FILTER VALVULUM SWITCH
  - BD - BLOWDOWN VALVE
  - THA - COMPRESSOR DISCHARGE THERMISTOR
  - THB - SEPARATOR THERMISTOR
  - XDA - PRESSURE TRANSDUCER
  - XDB - RESERVOIR PRESSURE TRANSDUCER
  - WU - MAGNETIC UNLOADER
  - CONNECTION TO CONTROL BOARD
  - PANEL TERMINAL BLOCK

MAIN MOTOR	PV STARTER
FAN MOTOR	NONE
CONTROLLER	RS 2090
ACCESSORY	NONE

Figure 4-9 – WIRING DIAGRAM – FULL VOLTAGE

302EDE797-A  
 (Ref. Drawing)  
 Page 1 of 2



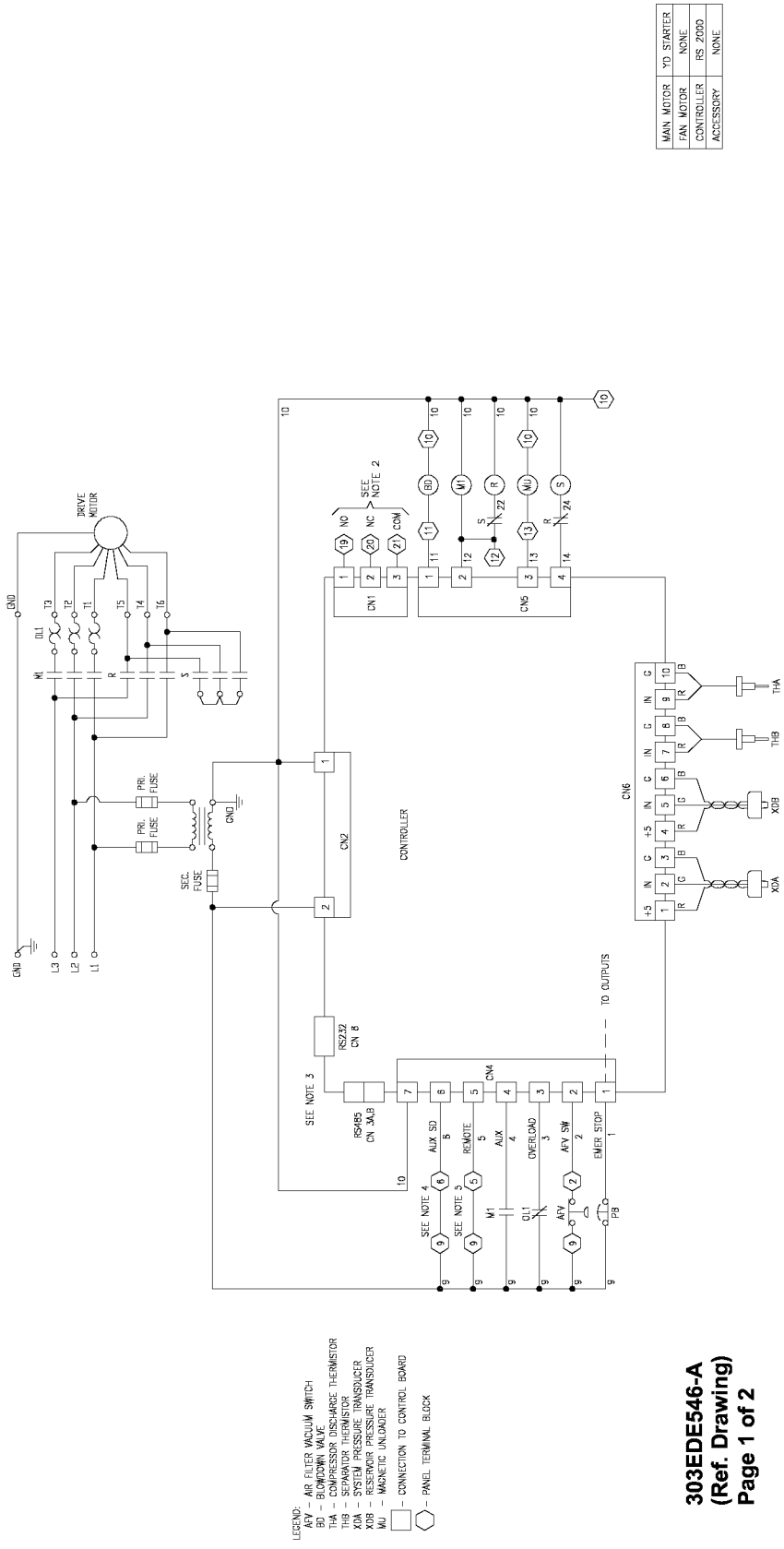

MAIN MOTOR	YD STARTER
FAN MOTOR	NONE
CONTROLLER	RS 200D
ACCESSORY	NONE

Figure 4-10 – WIRING DIAGRAM – WYE DELTA

LEGEND:  
 AVY - AIR FILTER VACUUM SWITCH  
 BD - BLOWDOWN VALVE  
 THA - COMPRESSOR DISCHARGE THERMISTOR  
 THB - SEPTANUM DISCHARGE THERMISTOR  
 XDA - RESISTOR PRESSURE TRANSDUCER  
 XDB - RESISTOR PRESSURE TRANSDUCER  
 MU - MAGNETIC UNLOADER  
 - CONNECTION TO CONTROL BOARD  
 - PANEL TERMINAL BLOCK

303EDE546-A  
 (Ref. Drawing)  
 Page 1 of 2



## SECTION 5 LUBRICATION OIL COOLER, OIL FILTER & SEPARATOR

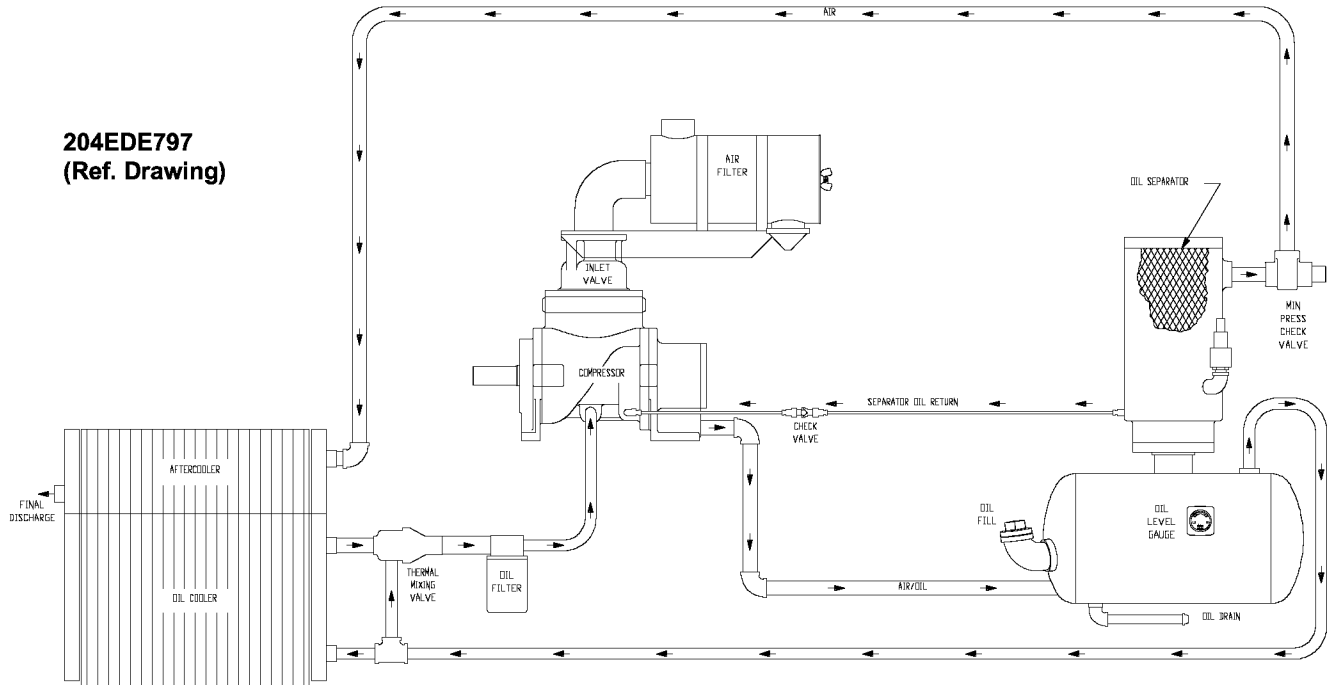

**Figure 5-1 – FLOW DIAGRAM – AIR/OIL SYSTEM**

**COMPRESSOR OIL SYSTEM** (Figure 5-1, page 31) cools the compressor, lubricates moving parts and seals internal clearances in the compression chamber.

The oil inlet line is connected at the bottom of the oil reservoir. Air pressure in the oil reservoir forces oil through the oil cooler, thermostatic mixing valve, oil filter and into the compressor main oil gallery.

The oil passes through internal passages for lubrication, cooling and sealing. The air-oil mixture is then discharged to the oil reservoir where a large part of the entrained oil drops out of the air stream; the air then passes through the final oil separator where most of the remaining oil is removed. The separated oil is returned to the compressor and the air passes to the final discharge line.

**RECOMMENDED LUBRICANT** - Gardner Denver compressors are factory filled with AEON lubricants. These lubricants are formulated to the highest quality standards and are factory authorized, tested and approved for use in rotary screw compressors. AEON lubricants are available through your authorized Gardner Denver compressor distributor.

**OIL SPECIFICATIONS** - The recommended compressor lubricant is Gardner Denver AEON 4000 Lubricating Coolant which can be used for year-round operation except as noted in the "High Temperature Operation" paragraph below, or low temperature, see "Installation for Cold Weather," page 12. AEON 4000 Lubricating Coolant is a superior petroleum base lubricant formulated and containing additives for use in Gardner Denver compressors.



## CAUTION

**Specific AEON lubricants are recommended for use in this equipment. Other lubricants may cause excessive carry-over or compressor damage. Do not mix different types of lubricants or use inferior lubricants.**

**HIGH TEMPERATURE OPERATION** - If the discharge temperature is sustained between 200°F to 210° F (93°C to 99° C) for a period of more than four (4) hours due to continuing high ambient air temperature, use Gardner Denver AEON 9000SP Lubricating Coolant which is a superior synthetic lubricant. Short periods of up to four (4) hours of sustained discharge temperatures up to 210° F (99° C) do not require a change from the recommended year-round lubricant AEON 4000.

**COLD AMBIENT OPERATION** - See “Installation for Cold Weather Operation”, page 12 and Figure 2-3, page 11.

**ADDITION OF OIL BETWEEN CHANGES** must be made when the oil level is at the bottom of the red range on the gauge as read while the unit is running.

To add oil, follow these steps:

1. Be sure the unit is completely off and that no air pressure is in the oil reservoir.
2. Disconnect, tag and lockout the power supply to the starter.
3. Wipe away all dirt around the oil filler plug.
4. Remove the oil filler plug and add oil as required to return the oil level to the center of the green range.
5. Install oil filler plug, run and check for leaks.

**DO NOT OVERFILL.** The quantity required to raise the oil level from “ADD” to “FULL” is shown in Figure 5-2, page 32. Repeated addition of oil between oil changes may indicate excessive oil carry-over and should be investigated.

	40 & 50 HP (30 & 37 kW)
Refill Capacity for Normal Oil change .....	5.5 U.S. Gallons (20.75 Liters)
Red to Yellow Range .....	1.25 U.S. Gallons (4.75 Liters)

**Figure 5-2 – APPROXIMATE OIL SYSTEM CAPACITIES**



## DANGER

**Air/oil under pressure will cause severe personal injury or death. Shut down compressor, relieve system of all pressure, disconnect, tag and lockout power supply to the starter before removing valves, caps, plugs, fittings, bolts and filters.**



## DANGER

**Compressor, air/oil reservoir, separator chamber and all piping and tubing may be at high temperature during and after operation.**



## CAUTION

**Excessive oil carry-over can damage equipment. Never fill oil reservoir above the “FULL” marker.**

**LUBRICANT CHANGE PROCEDURE** - Upgrading to a longer life lubricant is essentially a very worthwhile practice. Following are the primary steps to be completed when upgrading or changing the type of lubricant.

1. Thoroughly drain system:
  - Drain oil from air end and cooler while hot.
  - Break low point connections and drain oil from pipe runs.
  - Dump oil from the filter and reinstall used filter.
2. Fill the system with a 50 percent charge of the new lubricant:
  - Start the machine and stay there to observe.
  - Allow the machine to run about five minutes at temperature, or until temperature stabilizes, then shut down.
3. Thoroughly drain the machine.
4. Change to new filter and separator.
5. Fill the system with a full charge of the new lubricant.
6. Machine should then be run normally, however, total run time after the initial change-out should be 50 percent of normal anticipated service life of the new lubricant.
  - Drain all lubricant from the system, change the filter and separator, and replace with a full charge of the new lubricant.
7. Subsequent lubricant change-outs should be at normal intervals. (See “Oil Change Interval”, Figure 5-3, page 34.)



## CAUTION

**Improper equipment maintenance with use of synthetic lubricants will damage equipment. Oil filter and oil separator change intervals remain the same as for AEON 4000 – See “Maintenance Schedule”, page 46.**



## DANGER

**Air/oil under pressure will cause severe personal injury or death. Shut down compressor, relieve system of all pressure, disconnect, tag and lockout power supply to the starter before removing valves, caps, plugs, fittings, bolts and filters.**



## WARNING

**High temperature operation can cause damage to equipment or personal injury. Do not repeatedly restart the unit after high temperature stops operation. Find and correct the malfunction before resuming operation.**



## WARNING

**All materials used in Gardner Denver compressor units are compatible with AEON 9000SP Lubricating Coolant. Use caution when selecting downstream components such as air line lubricating bowls, gaskets and valve trim.**

**AEON 9000SP Synthetic Lubricant is not compatible with low nitrile Buna N or acrylic paints. AEON 9000SP is compatible with most air system downstream components.**

Material Safety Sheets (MSDS) are available for all AEON lubricants from your authorized Gardner Denver distributor or by calling 217-222-5400.

<b>Discharge Temperature</b>	<b>AEON 4000 Change Interval</b>	<b>AEON 9000SP Change Interval</b>
Up to 180° F (82° C)	4000 hrs.	8000 hrs.
180° to 190° F (82° to 88° C)	3000 hrs.	6000 hrs.
190° to 200° F (88° to 93° C)	2000 hrs.	4000 hrs.
200° F+ (93° C)	1000 hrs.	2000 hrs.

**Figure 5-3 – OIL CHANGE INTERVAL**

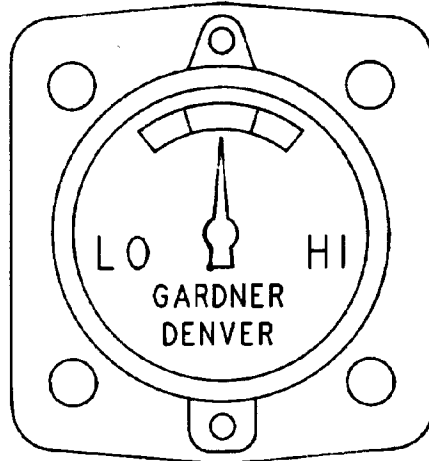

**Figure 5-4 – OIL LEVEL GAUGE**

**OIL LEVEL GAUGE** (Figure 1-3, page 3 and Figure 5-4) indicate the amount of oil in the oil reservoir. Read oil level only when unit is on. In operation the oil level will fluctuate as the compressor loads and unloads. Add oil only when the oil is at the bottom of the red range on the gauge as read when the compressor is on. Drain oil only when the oil level is above the center of the green range on the gauge as read when the compressor is on.

**MOISTURE IN THE OIL SYSTEM** - In normal humidity and with normal operating temperatures and pressures, the thermal mixing valve controls the oil temperature and prevents moisture contamination of the oil. Unusual cooling of the oil reservoir, short loaded cycle in high humidity or malfunctions of the thermal valve may result in moisture in the oil system which is detrimental to compressor lubrication and could cause oil carry-over. If moisture is observed in the oil reservoir, drain the moisture and correct the condition causing the accumulation. See "COMPRESSOR OIL SYSTEM CHECK", page 40 and "THERMAL CONTROL VALVE" (Thermostatic Mixing) , page 38.

**OIL CHANGE INTERVAL** - Recommended oil change intervals are based on oil temperature. Figure 5-3, page 34, shows how the change interval is affected by temperature.

When operating conditions are severe (very dusty, high humidity, etc.), it will be necessary to change the oil more frequently. Operating conditions and the appearance of the drained oil must be surveyed and the oil change intervals planned accordingly by the user. Gardner Denver offers a free oil analysis program with the AEON lubricants, and we recommend a sample be sent in at 100 hours on a new unit.

#### **DRAINING AND CLEANING OIL SYSTEM**



#### **DANGER**

**Ai/oil under pressure will cause severe personal injury or death. Shut down compressor, relieve system of all pressure, disconnect, tag and lockout power supply to the starter before removing valves, caps, plugs, fittings, bolts and filters.**

Always drain the complete system. Draining when the oil is hot will help to prevent varnish deposits and carry away impurities.

To drain the system, use one of the following methods:

1. If the unit is not elevated high enough to use the oil reservoir drain line to drain oil, a small hand, electric or air operated pump should be used to drain reservoir through the oil filler opening or from the drain valve.
2. If the unit is elevated so that the oil reservoir drain can be used, empty the oil reservoir through the drain valve to a suitable container or sump.
3. If the drained oil and/or the oil filter element are contaminated with dirt, flush the entire system: reservoir, oil cooler, mixing valve and lines. Inspect the oil separator elements for dirt accumulation; and replace if necessary. If a varnish deposit exists, contact the factory for recommendations for removal of the deposit and prevention of varnish.

### FILLING OIL RESERVOIR

 <b>DANGER</b>
<b>Air/oil under pressure will cause severe personal injury or death. Shut down compressor, relieve system of all pressure, disconnect, tag and lockout power supply to the starter before removing valves, caps, plugs, fittings, bolts and filters.</b>

 <b>DANGER</b>
<b>Compressor, air/oil reservoir, separation chamber and all piping and tubing may be at high temperature during and after operation.</b>

1. Be sure the unit is completely off and that no air pressure is in the oil reservoir.
2. Disconnect, tag and lockout the power supply to the starter.
3. Wipe away all dirt around the oil filler plug.
4. Remove the oil filler plug and add oil as required to return the oil level to the center of the green range on the gauge.
5. Install the oil filler plug and operate the unit for about a minute allowing oil to fill all areas of the system. Check for leaks.
6. Shut down unit, allowing the oil to settle, and be certain all pressure is relieved.
7. Add oil, if necessary, to bring level to center of the green range on the gauge.

On unloaded operation and after shutdown, some oil will drain back into the oil reservoir and the oil level will read over "FULL". DO NOT DRAIN OIL TO CORRECT. On the next start, oil will again fill the system and the gauge will indicate operating at the proper level. DO NOT OVERFILL as oil carry-over will result. The quantity of oil required to raise the oil level from "ADD" to "FULL" is shown in Figure 5-2, page 32. Repeated addition of oil between oil changes may indicate excessive oil carry-over and should be investigated.

Use only CLEAN containers and funnels so no dirt enters the reservoir. Provide for clean storage of oils. Changing the oil will be of little benefit if done in a careless manner.



### CAUTION

**Excessive oil carry-over can damage equipment. Never fill oil reservoir above the "FULL" marker.**

**COMPRESSOR OIL FILTER** (Figure 1-2, page 2) - This replaceable element filter is a vital part in maintaining a trouble-free compressor, since it removes dirt and abrasives from the circulated oil. The filter is equipped with a relief valve that opens in the event the element becomes dirty enough to block the flow of oil.



### CAUTION

**Improper oil filter maintenance will cause damage to equipment. Replace filter element every 1000 hours of operation. More frequent replacement could be required depending on operating conditions. A filter element left in service too long may damage equipment**

Use only the replacement element shown on the filter tag or refer to the parts list for the part number. Use the following procedure to replace the filter element. Do not disturb the piping.



### DANGER

**Air/oil under pressure will cause severe personal injury or death. Shut down compressor, relieve system of all pressure, disconnect, tag and lockout power supply to the starter before removing valves, caps, plugs, fittings, bolts and filters.**



### DANGER

**Compressor, air/oil reservoir, separation chamber and all piping and tubing may be at high temperature during and after operation.**

1. Stop the unit and be sure no air pressure is in the oil reservoir.
2. Remove the spin-on element.
3. Clean the gasket face of the filter body.
4. Coat the new element gasket with clean lubricant used in the unit.
5. Screw the new element on the filter body and tighten by hand. **DO NOT OVERTIGHTEN ELEMENT.**
6. Run the unit and check for leaks.

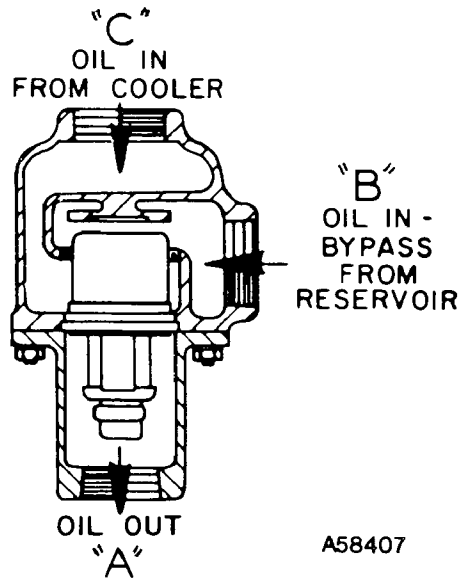

**Figure 5-5 – THERMOSTATIC MIXING VALVE**

**COMPRESSOR OIL COOLER** - The cooler fan is mounted on the compressor motor shaft; air is exhausted through the oil cooler and away from the unit. Do not obstruct air flow to and from the oil cooler. Allow a minimum of two (2) feet (.6M) clearance around the cooler. Keep both faces of the cooler core clean for efficient cooling of the compressor oil.

**THERMAL CONTROL (THERMOSTATIC MIXING) VALVE** (Figure 5-5) is installed in the system as shown in Figure 5-1, page 31. This valve is used to control the temperature of the oil. On start-up with unit cold, the element is open to bypass, allowing oil to pass directly from the reservoir to compressor during warm-up. As oil warms, the element gradually closes to the bypass allowing more of the oil from the cooler to mix with oil from the bypass.

After the unit is warmed up, the mixing valve maintains oil injection temperature into the compressor at a minimum of 170° F (77° C). This system provides proper compressor warm-up and prevents moisture contamination of the oil.

To check the element, heat in oil - it should be fully extended at 170° F (77° C). If the unit shuts down due to high air discharge temperature, the cause may be that the element is stuck open to the bypass, in which case bypass lines (Figure 5-1, page 31) will be hot to touch and lines out of mixing valve much cooler. When flushing the oil system, remove the mixing valve and clean all parts thoroughly.

**OIL RESERVOIR** - The oil reservoir-separator combines multiple functions into one vessel. The lower half is the oil reservoir, providing oil storage capacity for the system and the top portion, a primary oil separation means. The reservoir also provides limited air storage for control and gauge actuation.

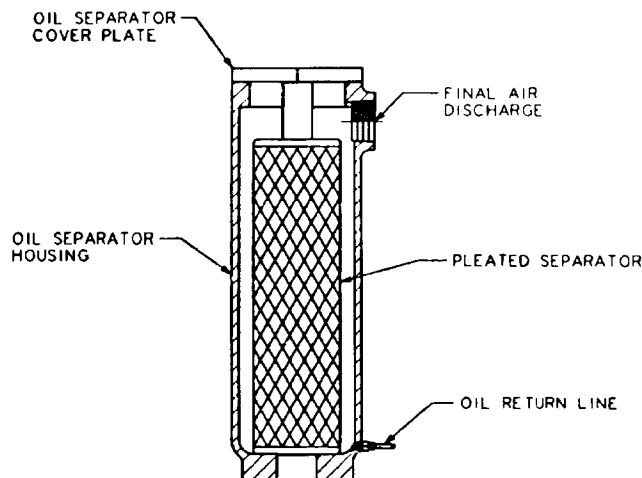

**Figure 5-6 – OIL SEPARATOR**

**COMPRESSOR (GD ELIMINATOR) OIL SEPARATOR** - The compressor oil separator located in a separate housing, consists of a renewable cartridge-type separator element and provides the final removal of oil from the air stream. See Figure 5-6.

Oil impinging on the inside of the separator element drains directly back into the oil reservoir by gravity. Oil collected outside the element is returned through tubing to the compressor cylinder.

Oil carry-over through the service lines may be caused by a faulty oil separator, overfilling of the oil reservoir, oil that foams, oil return line malfunction, or water condensate in the oil. If oil carry-over occurs, inspect the separator only after it is determined that the oil level is not too high, the oil is not foaming excessively, the oil return tube from the bottom of the separator to the compressor cylinder is not clogged or pinched off, the check valve in the oil return is functioning properly, and there is not water or an oil/water emulsion in the oil.

Oil carry-over malfunctions of the oil separator are usually due to using elements too long, heavy dirt or varnish deposits caused by inadequate air filter service, use of improper oil, or using oil too long for existing conditions. Excessive tilt angle of the unit will also hamper separation and cause oil carry-over.

Oil separator element life cannot be predicted; it will vary greatly depending on the conditions of operation, the quality of the oil used and the maintenance of the oil and air filters. The condition of the separator can be determined by pressure differential or by inspection.

**Pressure Differential Gauging** - The “CHANGE SEPARATOR” message will flash when the pressure differential across the oil separator reaches approximately 8 psi (.6 bar). Replace the oil separator element at this time. If ignored, the unit will shut down and the display will indicate shutdown and the change separator LED will be on when the pressure differential reaches 15 psi (1 bar).

To measure the pressure differential, see Controller Manual 13-8-623, page 4, “Separator Pressure Differential”. Simply subtract the downstream reading from the upstream reading.



## CAUTION

**Using an oil separator element at excessive pressure differential can cause damage to equipment. Replace the separator when the “Change Separator” advisory appears.**

## NOTICE

**A sudden drop of zero pressure differential or sudden heavy oil carry-over may indicate a ruptured element.**

**Inspection** - After removal of separator element, shine a light inside the element to reveal areas of heavy dirt or varnish deposits or breaks (ruptures) in element media.

### **Removal Of Oil Separator For Inspection Or Replacement:**

1. Be certain the unit is off and all system pressure is relieved.
2. Disconnect, tag and lockout the power supply to the starter.
3. Remove the screws holding the top plate to the separator housing. Lift the top plate from the separator housing.
4. Lift the separator from the separator housing.
5. Inspect and/or replace the separator as necessary. Be sure the O-Ring is not damaged. Before installing (or re-installing) any separator, apply grease to the O-Ring. Oil will be wiped off by the chamfer and the ring could be damaged.
6. Remove any gasket material adhering to the top of the plate or separator housing, and install the new gasket.
7. Lower the separator into the housing and center the separator on the chamfer. Press the separator down into the housing. Do not use excessive force as separator damage can occur.
8. Place the spacer on the indent in the separator. Seat the top plate to the separator, spacer and separator housing. Install and tighten all cap screws.
9. Run the unit and check for leaks.

**COMPRESSOR OIL SYSTEM CHECK** - The following readings are based on ambient temperature of 80° F (27° C) with the system in good condition. The compressor should be at operating temperature at the time of the checks. One-half hour of loaded operation is usually sufficient to reach level-out operating temperatures.

**Air and Oil Discharge Temperature** - 170°F to 200° F (77°C to 93° C) - Read at the gauge on the instrument panel or check with a thermometer at the discharge housing.

**Compressor Oil Inlet Temperature** - 165°F to 175° F (74°C to 79° C) - Install a tee at the oil filter outlet and check with a thermometer.

**Oil Inlet Pressure** - Check at the fitting in the line near the compressor oil inlet. With air receiver pressure at 100 psi (6.9 bar), oil inlet pressure should be 65 to 75 psig (4.5 to 5.2 bar).

**Oil Cooler Oil Pressure Differential (Air-Cooled Radiator)** - Check differential across the oil system by measuring oil inlet pressure as described above.

**Oil Cooler Temperature Differential (Air-Cooled Radiator)** - The oil temperature differential depends on the temperature of the air at the oil cooler fan and cleanliness of the core faces. As ambient temperatures and core restrictions increase, the oil cooler outlet temperature will increase. The oil inlet temperature is approximately the same as the air discharge temperature - see the gauge on the instrument panel. The outlet oil temperature may be checked by installing a tee at the oil filter outlet.

## SECTION 6 AIR FILTER

---

201EDE797  
(Ref. Drawing)

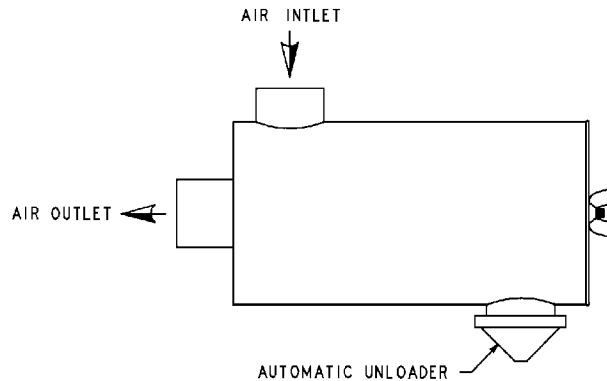

**Figure 6-1 – HEAVY DUTY AIR FILTER**

**GENERAL** - The air filter must receive proper maintenance if maximum service is to be obtained from the unit. Establishing adequate and timely filter service is **MOST IMPORTANT**. A wide range of operating hours is possible. With wide variation of dust conditions encountered, only experience can determine the proper time interval for servicing filters.

**HEAVY-DUTY AIR FILTER** - (Figure 6-1) Furnished as standard equipment on units with an enclosure is a heavy-duty washable element dry type air filter. The air filter must receive proper maintenance if maximum service is to be obtained from the unit. Establishing adequate and timely filter service is **MOST IMPORTANT**. Improperly maintained air filter can cause a loss of compressor air delivery.

**Filter Element** - Service the air filter element when the "CHANGE AIR FILTER" LED is illuminated. Clean every 50 to 150 operating hours depending on dust conditions.

### NOTICE

**Use only genuine Gardner Denver air filter elements on Gardner Denver compressor units. Genuine parts are available through your authorized Gardner Denver distributor**

To service:

1. Remove the wing nut and pull out the filter element.
2. Visually inspect the element. If cleaning is not necessary, reinstall the filter element. If the element requires cleaning, go through steps 3, 4 and 5.
3. Wash the element by soaking about 15 minutes in warm water with a mild non-sudsing detergent. Rinse the element thoroughly with clean water; a hose may be used if the water pressure does not exceed 40 psig (2.8 bar).
4. Inspect the element for ruptures or cracks in the pleated media; replace the element if any are found. Inspect the gasket on the bottom (outlet end) of the element; replace the entire element if the gasket is damaged, a spare element will keep downtime to a minimum.

5. Allow the element to air dry COMPLETELY. Do not expose the element to heat over 150° F (66° C). Install the element in the filter body and fasten securely with the wing nut.



## **WARNING**

**Do not oil this element. Do not wash in inflammable cleaning fluids. Do not use solvents other than water. Improper cleaning may damage the element.**



## **CAUTION**

**Never operate the unit without the element. Never use elements that are damaged, ruptured or wet. Never use gaskets that won't seal. Keep spare elements and gaskets on hand to reduce downtime. Store elements in a protected area free from damage, dirt and moisture. Handle all parts with care.**

## SECTION 7 BELT DRIVE

---

Proper drive belt tension and alignment are provided at the factory, however, good practice dictates checking the drive alignment and tension after shipment and before initial start-up.

Sheaves should align straight across the front with a straight edge. The best tension is just enough tension to keep belts from “squealing” on start-up.



### CAUTION

**Excessive belt tension can damage the equipment. Tension the belts as shown in Figure 7-1, page 45.**

Belts can be changed when necessary by the following instructions. First, disconnect, tag and lockout power to the starter. Then remove the wire guard. Then loosen, but do not remove, the four motor foot nuts.

Next, use the adjusting screws in the motor base to loosen belt tension. Remove the belts, and replace with new belts. Check for correct belt tension and re-attach the wire guard.



### CAUTION

**Interference between the fan and the orifice can damage equipment. Be certain the orifice has even clearance around the fan before starting the unit.**

**CHECKING BELT TENSION** - Using a spring scale, apply a perpendicular force to each belt at the midpoint of the span and measure the deflection. Correct deflection force and deflection are shown in Figure 7-1, page 45. To tighten belts, merely increase the center distance.

### NOTICE

**When a new set of belts is installed on a drive, the initial deflection force should be 1/3 greater than shown in Figure 7-1, page 45. Recheck tension frequently during the first 24 hours of operation.**

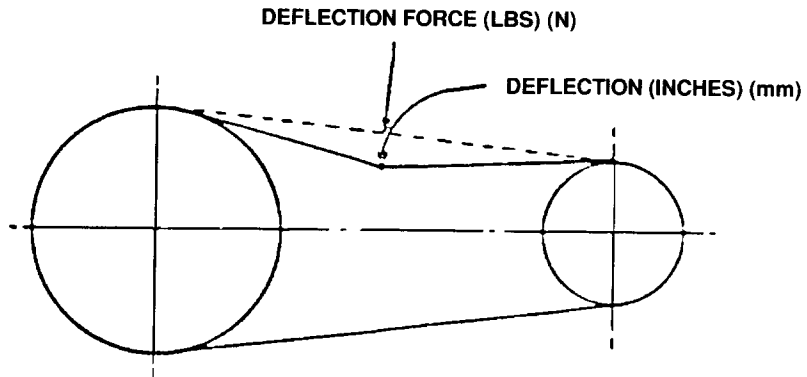

Motor H.P. (kW)	No. of Belts	Deflection Force Pounds (Newtons) (per belt)	Deflection in Inches (mm)
40 (30kW)	4	6 to 8.5 (1/3 to 1.0)	3/8 (9.5)
50 (37kW)	4	7 to 10 (1.5 to 2.2)	3/8 (9.5)

**Figure 7-1 – BELT TENSION 5VX BELTS**

## **SECTION 8 MAINTENANCE SCHEDULE**

---

### **SERVICE CHECK LIST –**

**Air Filter** - Operating conditions determine frequency of service. The “CHANGE AIR FILTER” display will flash to signal that the air filter requires servicing or changing. See “Air Filter”, SECTION 6, page 42.

**Oil Separator** - Operating conditions determine frequency of service. The “CHANGE SEPARATOR” display will flash to signal that oil separator element requires changing. See “Compressor Oil Separator” in SECTION 5, page 39, for further details.

**Motor Lubrication** - Refer to SECTION 2, page 9 and Maintenance Schedule Chart below.

### **Every 8 Hours Operation**

1. Check the reservoir oil level - add oil if required. See SECTION 5, page 35. If oil consumption is high, refer to “Excessive Oil Consumption”, page 49.
2. Observe if the unit loads and unloads properly.
3. Check discharge pressure and temperature.
4. Check Panel LED’s for advisories.

### **Every 125 Hours Operation**

Check for dirt accumulation on oil/aftercooler core faces and the cooling fan. If cleaning is required, clean the exterior fin surfaces of the cores by blowing compressed air carrying a nonflammable safety solvent in a direction opposite that of the cooling fan air flow. This cleaning operation will keep the exterior cooling surfaces clean and ensure effective heat dissipation.

### **Every 1000 Hours Operation**

Change the oil filter element.

### **Every 4000 Hours Operation**

Change the compressor lubricant. UNDER ADVERSE CONDITIONS, CHANGE MORE FREQUENTLY (refer to “Oil Change Interval”, page 35 ). Flush system if required.

### **Every Year**

Check the relief valve for proper operation. See SECTION 4, page 21.

**MAINTENANCE SCHEDULE (See detail notes above)**

<b>Maintenance Action</b>	<b>If Panel LED is Lit</b>	<b>Every 8 Hours</b>	<b>Every 125 Hours</b>	<b>Every 1000 Hours</b>	<b>Every 4000 * Hours</b>	<b>Every Year</b>
Change Air Filter	•					
Change Oil Separator	•					
Check Reservoir Oil Level		•				
Check for Proper Load/Unload		•				
Check Discharge Pressure/Temp		•				
Check Dirt Accumulation on Cooler			•			
Change Oil Filter Element				•		
Change Compressor Lubricant (AEON 4000)	•				•	
Check Relief Valve						•

## SECTION 9 TROUBLESHOOTING

---

SYSTEM	POSSIBLE CAUSE	REMEDY
Compressor fails to start	<ol style="list-style-type: none"> <li>1. Wrong lead connections</li> <li>2. Blown fuses in control box</li> <li>3. Motor starter overload heaters tripped</li> <li>4. Pressure in reservoir</li> <li>5. Read error message on control panel. See Control Manual 13-8-623, pages 3 &amp; 4</li> </ol>	<ol style="list-style-type: none"> <li>1. Change leads</li> <li>2. Replace fuse</li> <li>3. Reset and investigate cause of overload</li> <li>4. Inspect blowdown valve</li> <li>5. Replace switch</li> </ol>
Compressor starts but stops after a short time	<ol style="list-style-type: none"> <li>1. High discharge temperature</li> <li>2. High discharge temperature switch malfunction</li> <li>3. Blown fuse in starter/control box</li> <li>4. Motor starter overload heaters trip</li> </ol>	<ol style="list-style-type: none"> <li>1. See "High Temperature Operation", page 32.</li> <li>2. Replace switch</li> <li>3. Replace fuse (investigate if fuses continue to blow)</li> <li>4. Reset and investigate cause of overload</li> </ol>
Compressor does not unload (or load)	<ol style="list-style-type: none"> <li>1. Improperly adjusted control</li> <li>2. Air leak in control lines</li> <li>3. Restricted control line</li> <li>4. Subtractive pilot or blowdown valve malfunction</li> </ol>	<ol style="list-style-type: none"> <li>1. Refer to Controller Manual 13-8-623, page 8</li> <li>2. Determine source of leak and correct</li> <li>3. Clean control lines</li> <li>4. Repair, clean or replace valve</li> </ol>
Compressor cycles from load to unload excessively	<ol style="list-style-type: none"> <li>1. Insufficient receiver capacity</li> <li>2. Restriction in control tubing</li> <li>3. Subtractive pilot setting too high</li> </ol>	<ol style="list-style-type: none"> <li>1. Increase receiver size</li> <li>2. Inspect and clean control tubing</li> <li>3. Adjust the valve. See SECTION 4, page 24</li> </ol>
Compressor is low on delivery and pressure	<ol style="list-style-type: none"> <li>1. Restricted air filter</li> <li>2. Sticking inlet valve</li> <li>3. Subtractive pilot or unload pressure adjusted too low</li> <li>4. Minimum pressure valve stuck closed</li> </ol>	<ol style="list-style-type: none"> <li>1. Clean or replace filter</li> <li>2. Inspect and clean inlet valve</li> <li>3. Adjust the valve or unload pressure. See page 24.</li> <li>4. Replace valve</li> </ol>

<b>SYSTEM</b>	<b>POSSIBLE CAUSE</b>	<b>REMEDY</b>
High discharge air temperature	<ol style="list-style-type: none"> <li>1. Thermostatic mixing valve stuck open</li> <li>2. Dirty or clogged cooler face</li> <li>3. Insufficient cooling air flow</li> <li>4. Clogged oil filter or cooler (interior)</li> <li>5. Low compressor oil</li> </ol>	<ol style="list-style-type: none"> <li>1. Repair or replace valve</li> <li>2. Clean cooler</li> <li>3. Provide unrestricted supply of cooling air</li> <li>4. Replace filter or clean cooler</li> <li>5. Add oil to proper level</li> </ol>
Excessive oil consumption	<ol style="list-style-type: none"> <li>1. Oil carry-over through lines</li> <li>2. Oil leaks at all fittings and gaskets</li> </ol>	<ol style="list-style-type: none"> <li>1. See "Oil Carry-over", below</li> <li>2. Tighten or replace fittings or gasket</li> </ol>
Oil Carry-over	<ol style="list-style-type: none"> <li>1. Overfilling the reservoir</li> <li>2. Clogged, broken or loose oil return lines</li> <li>3. Ruptured oil separator element</li> <li>4. Loose assembly</li> <li>5. Foam caused by use of incorrect oil</li> <li>6. Inoperative minimum pressure valve</li> <li>7. Operation at elevated discharge temperatures</li> <li>8. Scavenge line check valve failure</li> <li>9. Water condensate in oil</li> </ol>	<ol style="list-style-type: none"> <li>1. Drain excess oil from system</li> <li>2. Tighten or replace faulty lines</li> <li>3. Replace element</li> <li>4. Tighten all fittings and gaskets</li> <li>5. Use Gardner Denver AEON 4000 or 9000SP Lubricating Coolant</li> <li>6. Replace valve</li> <li>7. Reduce temperature. See "High Temperature Operation", page 32.</li> <li>8. Replace check valve</li> <li>9. Check oil reservoir temperature, and if low, change thermal mixing valve element to higher temperature.</li> </ol>
"CHANGE SEPARATOR" light (Flashing or on steadily) <u>ON STARTUP</u>	<ol style="list-style-type: none"> <li>1. Separator differential is greater than 8 psid (.5 bars)</li> <li>2. Bad Transducer</li> </ol>	<ol style="list-style-type: none"> <li>1. Change Separator</li> <li>2. Verify readings with mechanical gauges. If defective, replace with 88H242.</li> </ol>

<b>SYSTEM</b>	<b>POSSIBLE CAUSE</b>	<b>REMEDY</b>
"CHANGE SEPARATOR" light (Flashing or on steadily) <u>ON</u> <u>STARTUP</u> (Continued)	3. Misadjusted minimum pressure valve	3. Set minimum pressure valve at 65 psig (4.5 bars)
	4. Sticky minimum pressure valve	4. Disassemble and clean
	5. Defective minimum pressure valve. [Won't set at 65 psig (4.5 bars)]	5. Rebuild or replace
"CHANGE SEPARATOR" light (Flashing or on steadily) <u>WHILE</u> <u>RUNNING</u>	1. Separator differential is greater than 8 psid (.5 bars)	1. Change Separator
	2. Electrical noise creating false readings	2. Make sure transducer wires are kept to a minimum length and are twisted
	3. Ruptured oil separator element	3. Replace element
	4. Loose assembly	4. Tighten all fittings and gaskets
	5. Foam caused by use of incorrect oil	5. Use Gardner Denver AEON 4000 Lubricating Coolant
	6. Inoperative minimum pressure valve	6. Clean out or replace valve
	7. Operation at elevated discharge temperatures	7. Reduce temperature. See "High Temperature Operation", page 32.
	8. Scavenge line check valve failure	8. Replace check valve
	9. Water condensate in oil	9. Check oil reservoir temperature, and if low, change thermal mixing valve element to higher temperature.

**GENERAL PROVISIONS AND LIMITATIONS**

Gardner Denver (the "Company") warrants to each original retail purchaser ("Purchaser") of its new products from the Company or its authorized distributor that such products are, at the time of delivery to the Purchaser, made with good material and workmanship. No warranty is made with respect to:

1. Any product which has been repaired or altered in such a way, in the Company's judgment, as to affect the product adversely.
2. Any product which has, in the Company's judgment been subject to negligence, accident, improper storage, or improper installation or application.
3. Any product which has not been operated or maintained in accordance with the recommendations of the Company.
4. Components or accessories manufactured, warranted and serviced by others.
5. Any reconditioned or prior owned product.

Claims for items described in (4) above should be submitted directly to the manufacturer.

**WARRANTY PERIOD**

The Company's obligation under this warranty is limited to repairing or, at its option, replacing, during normal business hours at an authorized service facility of the Company, and part which in its judgment proved not to be as warranted within the applicable Warranty Period as follows.

**AIRENDS**

Airends, consisting of all parts within and including the cylinder and gear housing, are warranted for 24 months from date of initial use or 27 months from date of shipment to the purchaser, whichever occurs first.

Any disassembly or partial disassembly of the airend, or failure to return the "unopened" airend per Company instructions, will be cause for denial of warranty.

**MAJOR PACKAGE COMPONENTS**

The drive motor, air or water cooled coolers and the Auto Sentry Controller are warranted for 24 months from date of initial use or 27 months from date of shipment to the first purchaser, whichever occurs first.

**OTHER COMPONENTS**

All other components are warranted for 12 months from date of initial use or 15 months from date of shipment to first purchaser, whichever occurs first.

**LABOR TRANSPORTATION AND INSPECTION**

The Company will provide labor, by Company representative or authorized service personnel, for repair or replacement of any product or part thereof which in the Company's judgment is proved not to be as warranted. Labor shall be limited to the amount specified in the Company's labor rate schedule.

Labor costs in excess of the Company rate schedule amounts or labor provided by unauthorized service personnel is not provided for by this warranty.

All costs of transportation of product, labor or parts claimed not to be as warranted and, of repaired or replacement parts to or from such service facilities shall be borne by the Purchaser. The Company may require the return of any part claimed not to be as warranted to one of its facilities as designated by Company, transportation prepaid by Purchaser, to establish a claim under this warranty.

Replacement parts provided under the terms of the warranty are warranted for the remainder of the Warranty Period of the product upon which installed to the same extent as if such parts were original components.

**DISCLAIMER**

The foregoing warranty is exclusive and it is expressly agreed that, except as to title, the company makes no other warranties, expressed, implied or statutory, including any implied warranty of merchantability.

The remedy provided under this warranty shall be the sole, exclusive and only remedy available to purchaser and in no case shall the company be subject to any other obligations or liabilities. Under no circumstances shall the company be liable for special, indirect, incidental or consequential damages, expenses, losses or delays howsoever caused.

No statement, representation, agreement, or understanding, oral or written, made by any agent, distributor, representative, or employee of the Company which is not contained in this Warranty will be binding upon the Company unless made in writing and executed by an officer of the Company.

This warranty shall not be effective as to any claim which is not presented within 30 days after the date upon which the product is claimed not to have been as warranted. Any action for breach of this warranty must be commenced within one year after the date upon which the cause of action occurred.

Any adjustment made pursuant to this warranty shall not be construed as an admission by the Company that any product was not as warranted.

# **Gardner Denver**

Specifications subject to change without notice.

Copyright © 1999 Gardner Denver, Inc.

Litho in U.S.A.

<http://www.gardnerdenver.com>

[mktg@gardnerdenver.com](mailto:mktg@gardnerdenver.com)

For additional information contact your local representative or



Gardner Denver Compressor and Pump Division,  
1800 Gardner Expressway, Quincy, Illinois 62301  
Customer Service Department Telephone:  
(800) 682-9868 FAX: (217) 224-7814

Sales and Service in all major cities.

For parts information, contact Gardner Denver,  
Master Distribution Center, Memphis, TN  
Telephone: (800) 245-4946 FAX: (901) 542-6159