GARDNER DENVER®

13-8-621
Version: 07
March 15, 2007

INTEGRA™
BASE-MOUNTED
COMPRESSORS

MODELS – EFC99A, EFC99F
20, 25 & 30 HP

OPERATING AND
SERVICE MANUAL



**MAINTAIN COMPRESSOR RELIABILITY AND PERFORMANCE WITH
GENUINE GARDNER DENVER® COMPRESSOR PARTS AND SUPPORT SERVICES**

Gardner Denver Compressor genuine parts, manufactured to design tolerances, are developed for optimum dependability – specifically for Gardner Denver compressor systems. Design and material innovations are the result of years of experience with hundreds of different compressor applications. Reliability in materials and quality assurance are incorporated in our genuine replacement parts.

Your authorized Gardner Denver Compressor distributor offers all the backup you'll need. A worldwide network of authorized distributors provides the finest product support in the air compressor industry. Your local authorized distributor maintains a large inventory of genuine parts and he is backed up for emergency parts by direct access to the Gardner Denver Master Distribution Center (MDC) in Memphis, Tennessee.

Your authorized distributor can support your Gardner Denver air compressor with these services:

1. Trained parts specialists to assist you in selecting the correct replacement parts.
2. Factory warranted new and remanufactured rotary screw airends. Most popular model remanufactured airends are maintained in stock at MDC for purchase on an exchange basis with liberal core credit available for the replacement unit.
3. A full line of factory tested AEON™ compressor lubricants specifically formulated for use in Gardner Denver compressors.
4. Repair and maintenance kits designed with the necessary parts to simplify servicing your compressor.

Authorized distributor service technicians are factory trained and skilled in compressor maintenance and repair. They are ready to respond and assist you by providing fast, expert maintenance and repair services.

For the location of your local authorized Gardner Denver Air Compressor distributor, refer to the yellow pages of your phone directory or contact:

Distribution Center:

Gardner Denver
Master Distribution Center
5585 East Shelby Drive
Memphis, TN 38141
Phone: (901) 542-6100
(800) 245-4946
Fax: (901) 542-6159

Factory:

Gardner Denver
1800 Gardner Expressway
Quincy, IL 62301
Phone: (217) 222-5400
Fax: (217) 224-7814

REMANUFACTURED AIRENDS

Whenever an airend requires replacement or repair, Gardner Denver offers an industry unique, factory remanufactured airend exchange program. From its modern Remanufacturing Center in Indianapolis, IN., Gardner Denver is committed to supplying you with the highest quality, factory remanufactured airends that are guaranteed to save you time, aggravation and money.

Immediately Available

Repair downtime costs you money, which is why there are over 200 remanufactured units in inventory at all times, ready for immediate delivery.

Skilled Craftsmen

Our Remanufacturing assembly technicians average over 20 years experience with air compression products.

Precision Remanufacturing

All potentially usable parts are thoroughly cleaned, inspected and analyzed. Only those parts that can be brought back to original factory specifications are remanufactured. Every remanufactured airend receives a new overhaul kit: bearings, gears, seals, sleeves and gaskets.

Extensive Testing

Gardner Denver performs testing that repair houses just don't do. Magnaflux and ultrasonic inspection spot cracked or stressed castings, monochromatic light analysis exposes oil leaks, and coordinate measurement machine inspects to +/- .0001", insuring that all remanufactured airends meet factory performance specifications.

Warranty

Gardner Denver backs up every remanufactured airend with a new warranty...18 months from purchase, 12 months from service. Gardner Denver remanufactured airends deliver *quality without question...year in and year out.* Call Gardner Denver for information on the airend exchange program and the name of your authorized distributor.

Phone Number: 800-245-4946 or
Fax: 901-542-6159

FOREWORD

Gardner Denver Rotary Screw compressors are the result of advanced engineering and skilled manufacturing. To be assured of receiving maximum service from this machine the owner must exercise care in its operation and maintenance. This book is written to give the operator and maintenance department essential information for day-to-day operation, maintenance and adjustment. Careful adherence to these instructions will result in economical operation and minimum downtime.



DANGER

Danger is used to indicate the presence of a hazard which will cause severe personal injury, death, or substantial property damage if the warning is ignored.



WARNING

Warning is used to indicate the presence of a hazard which can cause severe personal injury, death, or substantial property damage if the warning is ignored.



CAUTION

Caution is used to indicate the presence of a hazard which will or can cause minor personal injury or property damage if the warning is ignored.

NOTICE

Notice is used to notify people of installation, operation or maintenance information which is important but not hazard-related.

This book covers the following models:

HP	PSI	Air Cooled	Parts List	Controller Manual
20, 25 & 30	100, 125, 150, 175	EFC99A	13-8-515	13-8-623
20, 25 & 30	100, 125, 150, 175	EFC99F	13-8-533	13-8-623

TABLE OF CONTENTS

Maintain Compressor Reliability and Performance with Genuine Gardner Denver Compressor Parts and Support Services	i
Remanufactured Airends	i
Foreword	ii
Index.....	iv
List of Illustrations	vi
Section 1, General Information	1
Section 2, Installation.....	7
Section 3, Starting & Operating Procedures.....	14
Section 4, Controls & Instrumentation	17
Section 5, Lubrication, Oil Cooler, Oil Filter & Separator.....	24
Section 6, Air Filter.....	35
Section 7, Belt Drive.....	37
Section 8, Maintenance Schedule	40
Section 9, Troubleshooting	42

INDEX

Air Cooled Unit	7	Upgrade Procedure	28
Air Filter		Lubrication	
Element.....	35	Motor	12
Element Life.....	36	Lubrication, Cooling And Sealing.....	1
Section 6.....	35	Lubrication, Oil Cooler, Oil Filter & Separator	
Standard Duty.....	35	Section 5	24
Air Flow In Compressor System	1	Maintenance Schedule	
Air Receiver		Section 8	40
Auxiliary	10	Moisture Separator/Trap	
Air/Oil Separators.....	32	Optional	10
Belt Drive		Motor Lubrication	12
Checking Belt Tension.....	38	Oil Cooler	
Replacing Belts.....	37	Compressor	32
Replacing Compressor Sheave.....	38	Oil Filter.....	30
Section 7.....	37	Oil Level	
Cold Ambient Operation.....	25	Gauge.....	30
Cold Weather		Procedure For Checking	25
Installation	10	Oil Reservoir	32
Compression Principle	1	Drain.....	8
Compressor.....	1	Filling	27
Controls & Instrumentation		Oil Separator	
RS2000 Operation.....	17	Inspection	33
Control Devices	18	Removal For Inspection Or Replacement....	33
General Description.....	17	Oil Specifications	24
Section 4.....	17	Oil System	
Cooler		Addition Of Oil Between Changes.....	25
Compressor Oil.....	32	Compressor.....	24
Cooling, Sealing And Lubrication	1	Draining And Cleaning	27
Daily Check	16	Moisture.....	30
Decals	5, 6	Oil Change Interval	26
Discharge Service Line	11	Oil System Check	34
Electrical Wiring	11	Air And Oil Discharge Temperature	34
Enclosure	9	Compressor Oil Inlet Temperature.....	34
Foundation	8	Oil Cooler Oil Pressure Differential	34
General Information		Oil Cooler Temperature Differential	34
Section 1.....	1	Oil Inlet Pressure.....	34
Grounding.....	12	Piping	
High Temperature Operation	25	Control.....	10
Inlet Line.....	10	Pressure Differential Gauging.....	32
Installation		Prestart-Up Instructions	14
Cold Weather.....	10	Air Filter	14
General.....	7	Compressor Oil	14
Section 2.....	7	Electrical.....	14
Lifting Unit	7	Enclosure	15
Location.....	7	Grounding.....	14
Lubricant		Operating Mode.....	15
Recommended	24	Piping	14
		Rotation.....	15
		System Pressure	15
		Safety Precautions.....	3
		Sealing, Lubrication And Cleaning.....	1
		Separators	

Air/Oil	32
Service Check List	40
Air Filter	40
Every 1000 Hours Operation	40
Every 125 Hours Operation	40
Every 4000 Hours Operation	40
Every 8 Hours Operation	40
Every Year	40
Motor Lubrication	40
Sheave Alignment	37
Starting & Operating Procedures	
Section 3	14
Starting The Unit	16

Unit Cold	16
Unit Hot	16
Stopping The Unit	16
Trouble Shooting	
Section 9	42
Troubleshooting Voltage Problems	45
Valve	
Thermal Control (Thermostatic Mixing)	32
Wiring	
Electrical	11

LIST OF ILLUSTRATIONS

Figure 1-1 – Compressor Cycle	1
Figure 1-2 – Compressor Illustration.....	2
Figure 2-1 – Typical Compressor Room	8
Figure 2-2 – Air Flow Chart.....	8
Figure 2-3 – Cold Weather Installation	9
Figure 4-1 – Control Schematic	17
Figure 4-2 – Key Pad	18
Figure 4-3 – Wiring Diagram.....	22
Figure 5-1 – Flow Diagram.....	24
Figure 5-2 – Approximate Oil System Capacities	26
Figure 5-3 – Oil Change Interval	26
Figure 5-4 – Oil Level Gauge, Oil Fill And Oil Drain	30
Figure 5-5 – Oil Filter	31
Figure 5-6 – Oil Separator.....	34
Figure 6-1 – Air Filter	35
Figure 7-1 – Belt Tension – J Section Micro-V Belts	39

SECTION 1 GENERAL INFORMATION

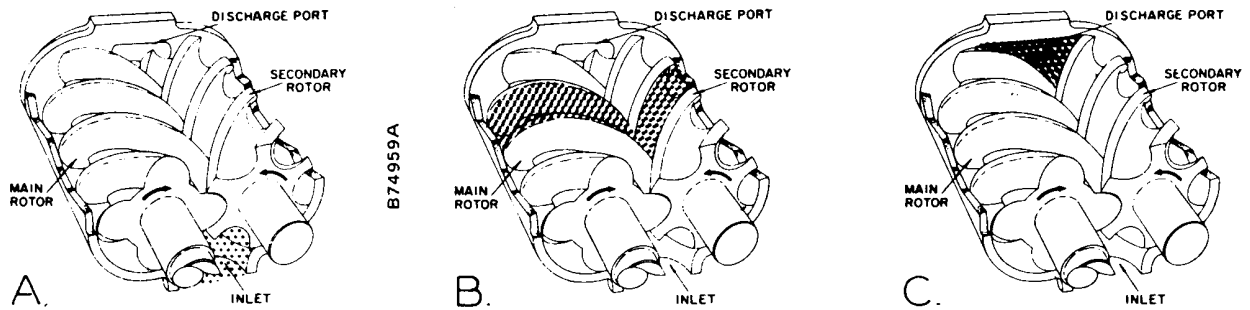

Figure 1-1 – COMPRESSOR CYCLE

COMPRESSOR - The rotary screw compressor is a single stage, positive displacement rotary machine using meshing helical rotors to effect compression. Both rotors are supported between high capacity roller bearings located outside the compression chamber. Single width cylindrical roller bearings are used at the inlet end of the rotors to carry part of the radial loads. Ball and roller bearings at the discharge end locate each rotor axially and carry all thrust loads and the remainder of the radial loads.

COMPRESSION PRINCIPLE (Figure 1-1) - Compression is accomplished by the main and secondary rotors synchronously meshing in a one-piece cylinder. The main rotor has four (4) helical lobes 90° apart. The secondary rotor has five (5) matching helical grooves 72° apart to allow meshing with main rotor lobes.

The air inlet port is located on top of the compressor cylinder near the drive shaft end. The discharge port is near the bottom at the opposite end of the compressor cylinder. *Figure 1-1 is an inverted view to show inlet and discharge ports.* The compression cycle begins as the rotors unmesh at the inlet port and air is drawn into the cavity between the main rotor lobes and the secondary rotor grooves (A). When the rotors pass the inlet port cutoff, air is trapped in the interlobe cavity and flows axially with the meshing rotors (B). As meshing continues, more of the main rotor lobe enters the secondary rotor groove, normal volume is reduced and pressure increases.

Oil is injected into the cylinder to remove the heat of compression and seal internal clearances. Volume reduction and pressure increase continues until the air/oil mixture trapped in the interlobe cavity by the rotors passes the discharge port and is released to the oil reservoir (C). Each rotor cavity follows the same "fill-compress-discharge" cycle in rapid succession to produce a discharge air flow that is continuous, smooth and shock free.

AIR FLOW IN THE COMPRESSOR SYSTEM (Figure 5-1, page 24) - Air enters the air filter and passes through the inlet unloader valve and on into the compression chamber where oil is injected into the air. After compression, the air/oil mixture passes into the oil reservoir where most of the entrained oil is removed by velocity change and impingement and drops back into the reservoir. The air and remaining oil then passes through the air/oil separator. The air then passes through the minimum pressure/check valve, the aftercooler and the moisture separator and into the plant air lines.

LUBRICATION, COOLING AND SEALING - Oil is forced by air pressure from the oil reservoir through the oil cooler, thermostatic mixing valve, and oil filter and discharge into the compressor main oil gallery. A portion of the oil is directed through internal passages to the bearings and shaft oil seal. The balance of the oil is injected directly into the compression chamber to remove heat of compression, seal internal clearances and lubricate the rotors.

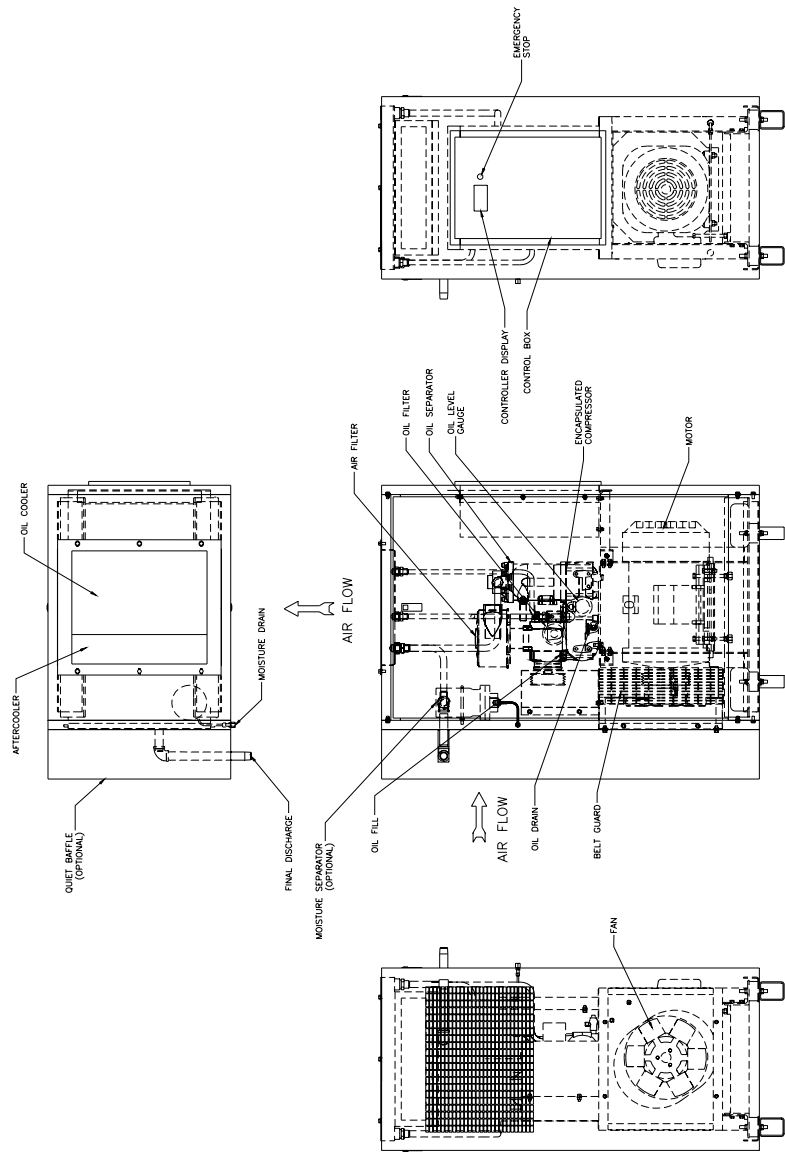

302EFC797-A
(Ref. Drawing)

Figure 1-2 – COMPRESSOR ILLUSTRATION

SAFETY PRECAUTIONS

Safety is everybody's business and is based on your use of good common sense. All situations or circumstances cannot always be predicted and covered by established rules. Therefore, use your past experience, watch out for safety hazards and be cautious. Some general safety precautions are given below:



DANGER

Failure to observe these notices could result in injury to or death of personnel.

- **Keep fingers and clothing away from revolving fan, drive coupling, etc.**
- **Do not use the air discharge from this unit for breathing – not suitable for human consumption.**
- **Do not loosen or remove the oil filler plug, drain plugs, covers, the thermostatic mixing valve or break any connections, etc., in the compressor air or oil system until the unit is shut down and the air pressure has been relieved.**
- **Electric shock can and may be fatal.**
- **Perform all wiring in accordance with the National Electrical Code (NFPA-70) and any applicable local electrical codes. Wiring and electrical service must be performed only by qualified electricians.**
- **Open the main disconnect switch, lockout and tagout before working on the control.**
- **Disconnect the compressor unit from its power source, lockout and tagout before working on the unit – this machine is automatically controlled and may start at any time.**



WARNING

Failure to observe these notices could result in damage to equipment.

- **Stop the unit** if any repairs or adjustments on or around the compressor are required
- **Disconnect the compressor** unit from its power source, lockout and tagout before working on the unit – this machine is automatically controlled and may start at any time.
- **An Excess Flow Valve** should be on all compressed air supply hoses exceeding 1/2 inch inside diameter. (OSHA Regulation, Section 1926.302, or local regulations)
- **Do not exceed the rated maximum pressure values** shown on the nameplate.
- **Do not operate unit** if safety devices are not operating properly. Check periodically. Never bypass safety devices.

DECALS

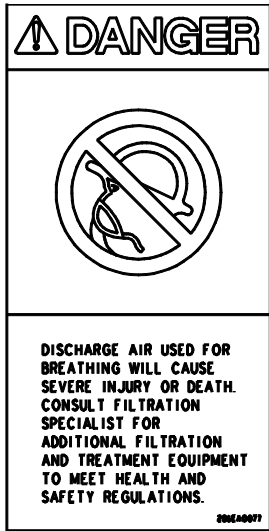

206EAQ077

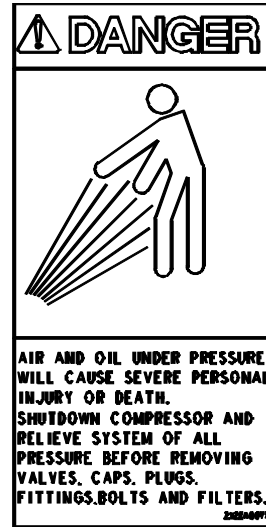

212EAQ077

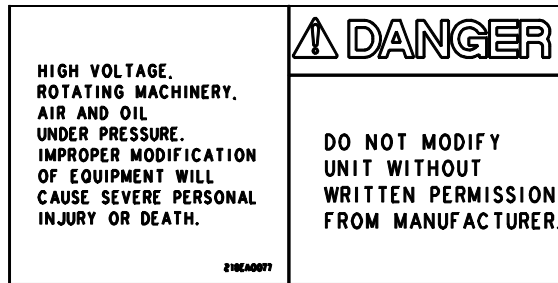

218EAQ077

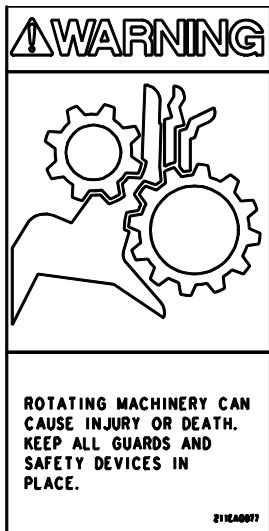

211EAQ077

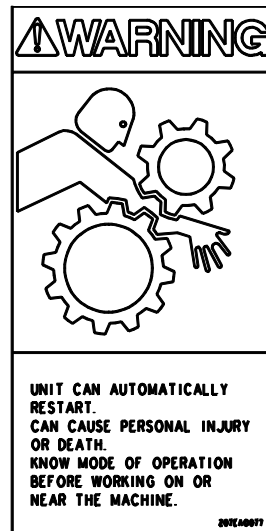

207EAQ077

DECALS

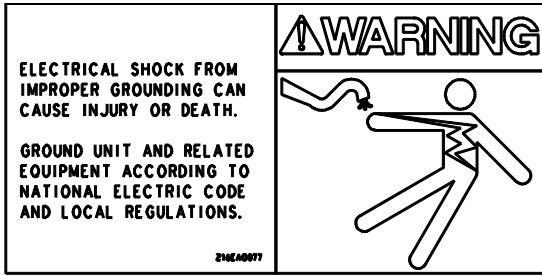

216EAQ077

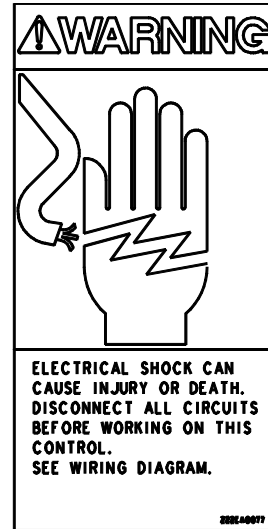

222EAQ077

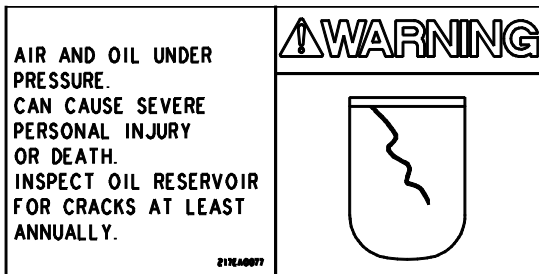

217EAQ077

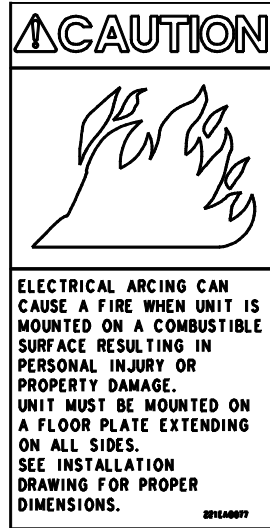

221EAQ077

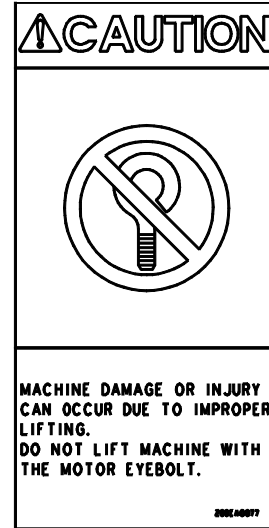

208EAQ077

SECTION 2 INSTALLATION

GENERAL - On receipt of the unit, check for any damage that may have been incurred during transit. Report any damage or missing parts as soon as possible.



CAUTION

Do not electric weld on the compressor or base; bearings can be damaged by passing of current.

LIFTING UNIT - Proper lifting and/or transporting methods must be used to prevent damage. Unit may be moved into location by lift truck.



CAUTION

Lift compressor unit under base only. Do not use other places such as motor, compressor or discharge manifold piping as lifting points.



DANGER

The eyebolts or lugs provided on the motor are for lifting the motor only and should not be used to lift any additional weight. All eyebolts must be securely tightened. When lifting the motor the lifting angle must not exceed 15 degrees. Failure to observe this warning may result in damage to equipment or personal injury.

LOCATION (Figure 2-1, page 8) - The compressor should be installed where it is protected from rain, snow and freezing temperatures, in a clean, well-lighted, well-ventilated area with ample space all around for maintenance. Select a location that provides a cool, clean, dry source of air. In some cases it may be necessary to install the air filter at some distance from the compressor to obtain proper air supply.

AIR-COOLED UNIT - A combination oil/aftercooler is supplied as standard equipment on all air-cooled units. The air-cooled unit with the standard enclosure requires sufficient flow for the compressor oil/aftercooling system and electric motor cooling (Figure 1-2, page 2). Air is drawn into the unit above the motor and discharged through the cooler. Do not block the air flow to and from the unit. Allow three and one half (3-1/2) feet to the nearest obstruction on the control box end of the unit. Allow two (2) feet to the nearest obstruction above and on other sides of unit.

For continuous efficiency, oil cooler cores must be periodically cleaned with either vacuum or compressed air. If wet cleaning is required, shield motor and spray on a mild soap solution and flush with clean water.



WARNING

For aluminum oil coolers, do not use any cleaning solution that is not compatible with aluminum. Use of improper solution may result in damage to the cooler.

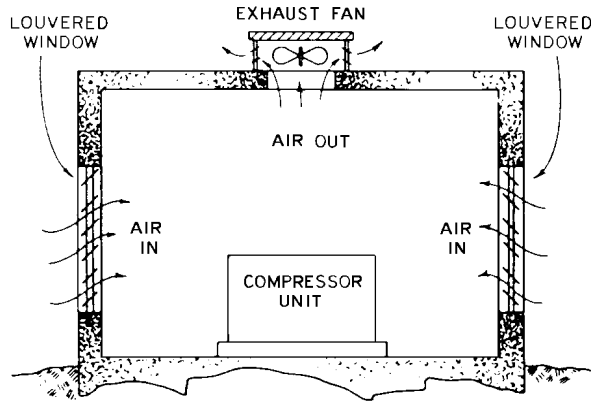

A75119

Figure 2-1 – TYPICAL COMPRESSOR ROOM

Minimum Air Flow* For Compressor And Cooling (cubic Feet/Minute)	
	Air Cooled
All Models	3000 cfm

* 80° F Inlet Air

Figure 2-2 – AIR FLOW CHART

FOUNDATION - The rotary screw compressor requires no special foundation, but should be mounted on a smooth, solid surface. Whenever possible install the unit near level. Temporary installation may be made at a maximum 5° angle lengthwise or 5° sidewise. Mounting bolts are not normally required. However, installation conditions such as piping rigidity, angle of tilt, or danger of shifting from outside vibration or moving vehicles may require the use of mounting bolts and shims to provide uniform support for the base. Belt alignment and tension should be checked after installation. (For information on belt alignment and tension, see SECTION 7, page 37.)

OIL RESERVOIR DRAIN - The oil drain is piped from the bottom of the reservoir to the side of the frame. This drain is approximately 20 inches above the floor level.



CAUTION

If the compressor unit base is raised above floor level, the space between the floor and the base bottom must be closed with solid material all around to prevent recirculation of hot air from the oil cooler end and over temperature operation.

ENCLOSURE - The compressor, electric motor, oil cooler and aftercooler are mounted inside the enclosure.

Service panels are provided for maintenance access. Be sure to allow enough space around the unit for the panels to be removed. Any of the enclosure panels may be removed by opening the latch and lifting it up slightly.



DANGER

Do not operate the compressor with the fan and belt guard removed. Exposed fan and belts may cause injury to personnel.



CAUTION

The enclosure doors and panels must be closed and latched while the compressor is operating. Failure to close and latch the doors and panels will cause high temperature shutdowns.

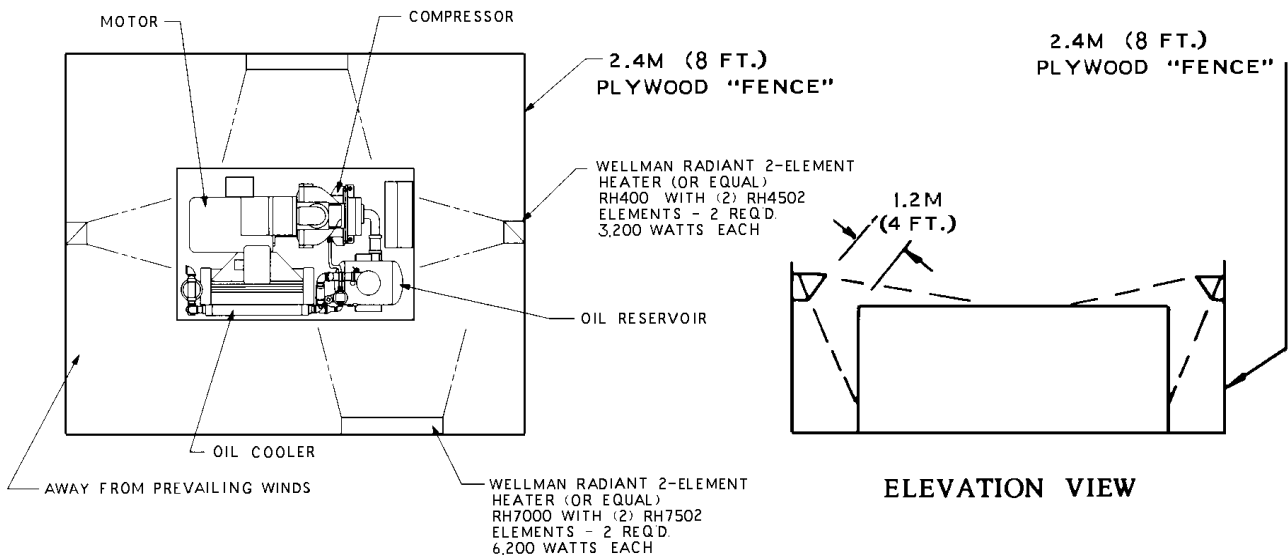

Figure 2-3 – COLD WEATHER INSTALLATION

INSTALLATION FOR COLD WEATHER OPERATION (Figure 2-3, page 10) - It is recommended that the unit be installed inside a shelter that will be heated to temperatures above freezing (32° F, 0° C). This will eliminate many of the problems associated with operating units in cold climates, such as freezing in control lines and downstream of the cooler.

Refer to Engineering Data Sheet 13-9-411 for the advantages of using the heat recovered from rotary compressors. This heat recovery could easily pay for an adequate shelter for the unit.

When an outside installation must be made, the precautions required will depend on the severity of the environment. The following are general guidelines for outside installations:

Cold Weather (Down To +10° F)

1. Be sure all drains, traps, and control lines, including pressure transducer lines are heated to avoid freezing of condensate. Heat tape with thermostat control is generally satisfactory for this purpose and can be obtained at various local plumbing or hardware outlets at nominal cost.
2. Provisions to bypass the aftercooler must be made. Since cold air contains very little moisture, successful operation can be achieved without the aftercooler.
3. Provide at least some simple shelter such as a plywood windbreak to protect against drifting snow.
4. Use only Gardner Denver AEON 9000SP lubricant.
5. Monitor unit carefully during start-up and operation to be sure it is functioning normally.

Remember unsheltered (outside) installations should be avoided where possible. Installation next to a heated building where enough heat can be used to keep the compressor room above freezing will save many complications in the operation and installation of the unit.

AUXILIARY AIR RECEIVER - An auxiliary air receiver is not required if the piping system is large and provides sufficient storage capacity to prevent rapid cycling. When used, an air receiver should be of adequate size, provided with a relief valve of proper setting, a pressure gauge and a means of draining condensate

STANDARD MOISTURE SEPARATOR/TRAP - The unit is equipped with a built-in aftercooler, a combination moisture separator and trap piped into the system down stream of the aftercooler.

CONTROL PIPING - Control piping is not necessary since the rotary screw unit is factory wired and piped for the control system specified.

INLET LINE - Where an inlet line is used between the air filter and the compressor, it must be thoroughly cleaned on the inside to prevent dirt or scale from entering the compressor. **If welded construction is used, the line must be shot blasted and cleaned to remove welding scale.** In either case, the inlet line must be coated internally by galvanizing or painting with a moisture and oil-proof sealing lacquer. Up to ten (10) feet in length, the inlet line should be the full size of the inlet opening on the compressor. If an extra-long line is necessary, the pipe size should be increased according to "Inlet Line Length Chart", page 11.

Accessibility for inlet air filter servicing must be considered when relocating the filters from the unit to a remote location.

INLET LINE LENGTHS

Length of Inlet Line	Diameter of Pipe Size
0 to 10 Feet	Same as Compressor Inlet Opening
10 to 17 Feet	One Size Larger Than Inlet Opening
17 to 38 Feet	Two Sizes Larger Than Inlet Opening

DISCHARGE SERVICE LINE - The discharge service line connection is made at the left hand corner of the package when viewed from the control box end. A hand operated valve, (air service valve) must be installed between the unit and the customer's air system. If a fast operating valve such as a ball valve is used, it must be closed slowly to give the intake valve time to shut and keep the discharge pressure from spiking.



WARNING

The controller has an automatic start/stop sequence built in. You do NOT need to close the air service valve. Closing the air service valve on start-up or prior to shutdown will cause rapid cycling, and could cause a high pressure shutdown.

When manifolding two or more rotary screw units on the same line, each unit is isolated by the check valve in the unit discharge line.

If a rotary screw unit is manifolded to another compressor, be sure the other compressor has a check valve in the line between the machine and the manifold.

If a rotary screw and a reciprocating compressor are manifolded together, an air receiver must be located between the two units.



DANGER

Discharge air used for breathing will cause severe injury or death.

Consult filtration specialists for additional filtration and treatment equipment to meet health and safety standards.

ELECTRICAL WIRING - Standard Units - The compressor package is factory wired for all connections from the starter to the motor, for the horsepower and voltage specified on the order. The standard unit is supplied with open drip proof motors, and a NEMA 12 starter and controls enclosure. Totally enclosed motors and NEMA 4 enclosures are available as factory options. See "Location" paragraph on page 7, for distance to the nearest obstruction on the control box side of the package.

Perform all wiring in accordance with the National Electrical Code (NFPA-70) and any applicable local electrical codes. Wiring must be performed only by qualified electricians.



WARNING

Electrical shock can cause injury or death. Open main disconnect switch, lockout and tagout before working on control box.

GROUNDING - Equipment must be grounded in accordance with Section 250 of the National Electrical Code.



WARNING

Failure to properly ground the compressor package could result in injury or death. Install ground wiring in accordance with the National Electrical Code and any applicable local codes.

MOTOR LUBRICATION - Long time satisfactory operation of an electric motor depends in large measure on proper lubrication of the bearings. The following charts show recommended grease qualities and regreasing intervals for ball bearing motors. For additional information, refer to the motor manufacturer's instructions.

The following procedure should be used in regreasing:

1. Stop the unit.
2. Disconnect, lockout and tagout the unit from the power supply.
3. Remove the relief plug and free hole of hardened grease.
4. Wipe lubrication fitting clean and add grease with a hand-operated grease gun.
5. Leave the relief plug temporarily off. Reconnect unit and run for about 20 minutes to expel the excess grease.
6. Stop the unit. Replace the relief plug.
7. Restart the unit.



WARNING

Rotating machinery can cause injury or death. Open main disconnect, lockout and tagout power supply to starter before working on the electric motor.

ELECTRIC MOTOR GREASE RECOMMENDATIONS (-30° TO 50° C)

MANUFACTURER	TRADE NAME
CHEVRON	SRI #2
SHELL	DOLIUM R
EXXON	UNIREX #2
EXXON	POLYREX

ELECTRIC MOTOR REGREASING INTERVAL

Type of Service	Typical	Rating	Relubrication Interval
Standard	One or Two Shift Operation	Up to 150 HP (112 KW)	18 Months
		Above 150 HP (112 KW)	12 Months
Severe	Continuous Operation	Up to 150 HP (112 KW)	9 Months
		Above 150 HP (112 KW)	6 Months
Very Severe	Dirty Locations, High Ambient Temperature	Up to 150 HP (112 KW)	4 Months
		Above 150 HP (112 KW)	2 Months

SECTION 3 STARTING & OPERATING PROCEDURES

PRESTART-UP INSTRUCTIONS - A new unit as received from the factory has been prepared for shipping only. Do not attempt to operate the unit until checked and serviced as follows:

1. **Compressor Oil** - The oil must be checked before starting the unit and every 8 hours of operation. For instructions on checking the oil and the proper oil level, refer to "Compressor Oil Filter", SECTION 5, page 24.

Do not mix different type oils. Unit is shipped filled with Gardner Denver AEON 4000 Lubricating Coolant which is suitable for the first 4000 hours under normal operating conditions. AEON 9000SP is also available. Check the decal on the reservoir to be sure which lubricant is in the machine.

REPLACE OIL FILTER EVERY 1000 HOURS.

NOTICE

Regular maintenance and replacement at required intervals of the oil filter, air filter and air/oil separator is necessary to achieve maximum service and extended drain intervals of AEON 4000 lubricant. Use only genuine Gardner Denver filters designed and specified for this compressor.



DANGER

Always stop the unit and release air pressure before removing oil filler plug. Failure to release pressure may result in personal injury or death.

2. **Air Filter** - Inspect the air filter to be sure it is clean and tightly assembled. Refer to SECTION 6, page 35 for complete servicing instructions. Be sure the inlet line, if used, is tight and clean.
3. **Piping** – Refer SECTION 2, page 11 "Discharge Service Line" and make sure all piping meets all recommendations.

Electrical - Check the wiring diagrams furnished with the unit to be sure it is properly wired. See

4. **4-3**, page 22 and 22, for general wiring diagrams and SECTION 2, page 7, for "Electrical Wiring".
5. **Grounding** - Unit must be properly grounded according to Section 250 of the National Electrical Code.



WARNING

Failure to properly ground the compressor package could result in controller malfunction.

6. **Rotation** - Check for correct motor rotation by jogging the motor. See "Unit Setup Adjustments" in Controller Operating and Service Manual. Compressor drive shaft rotation must be counterclockwise, standing facing the compressor sheave.



WARNING

Operation with incorrect motor rotation can damage equipment and cause oil eruption from the compressor inlet. When checking motor rotation, induce minimum rotation (less than one revolution if possible). Never allow motor to reach full speed.



WARNING

The compressor unit's direction of rotation must be checked every time the compressor is reconnected to the power supply.

7. **System Pressure** - The discharge pressure of the unit is set at the factory. To change the discharge pressure, set the controls to the desired load pressure. **DO NOT EXCEED THE MAXIMUM OPERATING PRESSURE ON THE COMPRESSOR NAMEPLATE.** See "Operating Adjustments" in Controller Operating and Service Manual.



WARNING

Operation at excessive discharge air pressure can cause personal injury or damage to equipment. Do not adjust the full discharge air pressure above the maximum stamped on the unit nameplate.

8. **Operating Mode** - Refer to SECTION 4, page 17 for detailed information on the control system.
9. **Enclosure** - Check for damaged panels or doors. Check all screws and latches for tightness. Be sure doors are closed and latched.



DANGER

The compressor starts and stops automatically. Automatic restarting can cause injury or death. Open, lockout and tagout main disconnect and any other circuits before servicing the unit.



WARNING

The enclosure doors must be in place and fastened down to keep the compressor package from overheating when the compressor is running.



WARNING

After an emergency stop, be sure that the pressure in the air/oil reservoir is less than 5 psig. Wait one minute or more before restarting.



WARNING

The controller has an automatic start/stop sequence built in. You do NOT need to close the air service valve. Closing the air service valve on start-up or prior to shutdown will cause rapid cycling, and could cause a high pressure shutdown.

STARTING THE UNIT - Observe the following starting procedures:

Unit Cold:

1. Open the air service valve (customer furnished) between the main air system and the check valve on the package.
2. Turn on power to the compressor package. To start press STOP/RESET, then press RUN.
3. Run for approximately five minutes or until the temperature stabilizes.

The unit is equipped with a minimum (45 psig) pressure/check valve. No special procedure is required to maintain the unit reservoir pressure.

Unit Hot (No warm-up period is required):

1. Open the air service valve (customer furnished) between the main air system and the check valve on the package.
2. Run for approximately one minute. The unit is equipped with a minimum (45 psig) pressure/check valve, no special procedure to maintain the unit reservoir pressure is required.

DAILY CHECK - Refer to "Maintenance Schedule," SECTION 8 page 40.

STOPPING THE UNIT:

1. To stop compressor operation, press STOP/RESET.
2. Wait approximately one minute to allow the compressor to stop. The oil reservoir will automatically blow down as the motor stops.

SECTION 4 CONTROLS & INSTRUMENTATION

GENERAL DESCRIPTION

The Gardner Denver rotary screw compressor is prewired with all controls, motor, and starter for the voltage and horsepower at the time of ordering. It is necessary only to connect the compressor unit to the correct power supply and to the shop air line. A standard compressor unit consists of the compressor, oil reservoir, oil cooling system and filter, motor type as specified, NEMA 12 starter / control box, and control components as described below.

RS2000® OPERATION

Operation of the "RS2000" is dependent on selection of an operating mode from the controller keypad. Prior to starting, the STOP/RESET key must be pressed to place the controller into its READY state (as indicated on the display). Compressor operation may then be started by pressing the RUN key. While in any operating mode, the display will indicate the mode, and the operating light will be on.

Press the STOP/RESET key at any time to stop the compressor under normal conditions.

AUTOMATIC is the most common selected mode of operation, as it automatically will operate the compressor unit in the most efficient manner for the demand of the air system. Refer to the controller manual for descriptions of other modes.

 WARNING
Automatic restarting or electrical shock can cause injury or death. Open, lockout and tagout main disconnect and any other circuits before servicing unit.

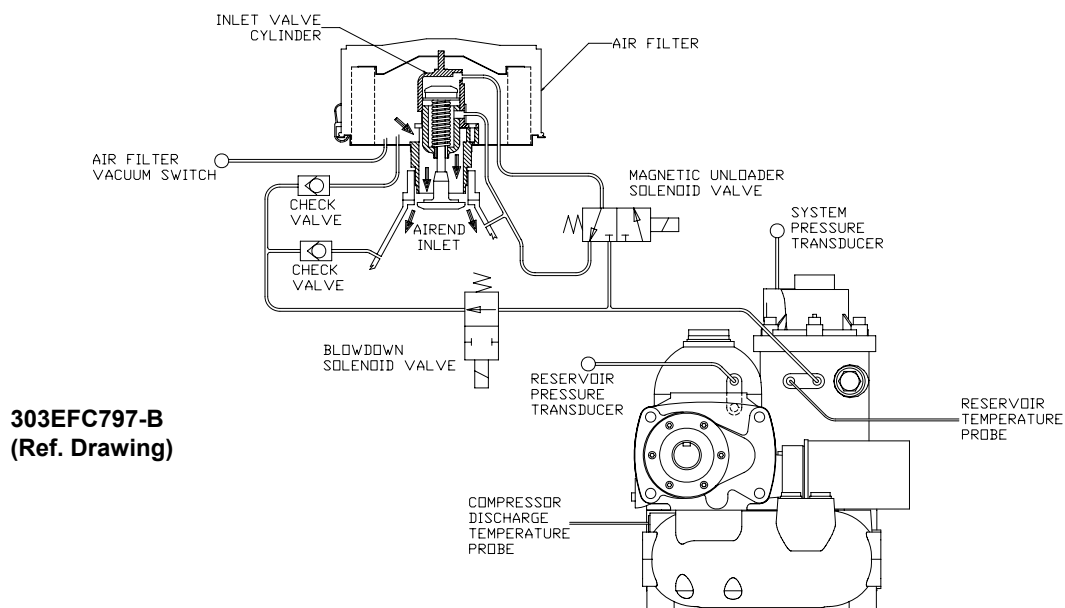

Figure 4-1 – CONTROL SCHEMATIC

CONTROL DEVICES

Controller - This compressor unit features the "RS2000" controller, which integrates all the control functions under microprocessor control. Its functions include safety and shutdown, compressor regulation, operator control, and advisory/maintenance indicators. The keypad and display provide the operator with a logical and easily operated control of the compressor and indication of its condition. The controller is factory adjusted for the compressor package, but allows tuning for specific applications.

Detailed instructions for the controller are found in the "RS2000" Controller Operating and Service Manual.



Figure 4-2 – KEY PAD

Relief Valve - A pressure relief valve is installed in the final discharge line and set to approximately 120-125% of the unit's full load operating pressure for protection against overpressure. Periodic checks should be made to ensure its operation.

The relief valve should be tested for proper operation at least once every year. To test the relief valve, raise the system operating pressure to 75% of the relief valve set pressure and manually open the valve by turning the cap.

WARNING

When the relief valve opens, a stream of high velocity air is released, resulting in a high noise level and possible discharge of accumulated dirt or other debris. Always wear eye and ear protection and stand clear of the discharge port when testing the relief valve to prevent injury.

CAUTION

Never paint, lubricate or alter a relief valve. Do not plug vent or restrict discharge.

WARNING

Operation of the unit with improper relief valve setting can result in severe personal injury or machine damage. Ensure properly set valves are installed and maintained.

Oil Level Gauge - This gauge is located on the oil reservoir and indicates the oil level. See "Oil Level Gauge", Figure 5-4, page 30, for how to read oil level.

Minimum Discharge Pressure/Check Valve - An internal spring-loaded minimum pressure valve is used in the final discharge line to provide a positive pressure on the coolant system of the compressor even if the air service valve is fully open to atmospheric pressure. This valve also functions as a check valve to prevent back flow of air from the shop air line when the unit stops, unloads, or is shut down.

The valve incorporates an orifice which, when air is flowing through it, maintains pressure in the oil reservoir. A spring-loaded piston valve senses air pressure on the upstream (reservoir) side of the valve. When the system pressure rises, the spring is overridden and the valve opens to full porting.

Inlet Valve (Figure 4-1, page 17) - The Inlet valve restricts the inlet to control delivery and closes to unload the compressor. At shutdown, the inlet valve closes to prevent the back flow of air.

The inlet valve position is controlled by air pressure in its piston cylinder, which is controlled by the "RS2000" through the magnetic unloader solenoid valve. When the top of the cylinder is pressurized, the inlet opens for full air delivery. When pressure is relieved from the cylinder, the inlet valve closes to restrict air flow and compressor delivery.

Magnetic Unloader Solenoid Valve (Figure 4-1, page 17) - This valve controls the position of the inlet valve in response to signals from the "RS2000". When de-energized, pressure is relieved from the top of the inlet valve cylinder to unload the compressor. When the solenoid valve is energized, reservoir pressure is supplied to the top of the cylinder to load the compressor.

Check Valve (Figure 4-1, page 17) - This valve is normally closed while the compressor is loaded or stopped. While running unloaded, it opens to admit a small amount of purge air to the compressor inlet. This reduces compressor knock, and provides enough air to pressurize the controls during startup.

Blowdown Valve (Figure 4-1, page 17) - The blowdown valve is a two-way solenoid valve which is piped into the oil reservoir outlet ahead of the minimum pressure valve. When the solenoid is de-energized, the valve opens and the coolant system is blown down. When the solenoid is energized, the valve closes to allow the coolant system to pressurize.

System Pressure Transducer (Figure 4-1, page 17) - This transducer is connected after the minimum pressure valve. It converts the pressure in the plant air system into an electrical signal for use by the "RS2000" controller for modulation and control.

Reservoir Pressure Transducer (Figure 4-1, page 17) - This transducer is connected to the coolant system. Its signal is used to prevent loaded starts, monitor oil pressure, and to monitor the condition of the separator.

Air Filter Vacuum Switch (Figure 4-1, page 17) - This switch is used to monitor air filter condition and alert the user if the filter requires service or replacement.



CAUTION

Machine damage will occur if compressor is repeatedly restarted after any one of the shutdown modes stops operation of the unit. Find and correct the malfunction before resuming operation.

Discharge Thermistor (Figure 4-1, page 17) - This sensor is located directly in the compressor discharge. Its signal is used to monitor compressor temperature and shut down the compressor if a coolant problem is detected.

Reservoir Thermistor (Figure 4-1, page 17) - This sensor is located in the reservoir/separator housing and is used to monitor temperature and shut down the compressor if temperature problems occur at the separator.

Emergency Stop Pushbutton - This is a maintained pushbutton, and removes power from the controller outputs regardless of controller status. It is located on the upper section of the control box door, next to the keypad. This should be used for emergency purposes only - use the keypad [STOP/RESET] for normal controlled stopping.



WARNING

Automatic restarting or electrical shock can cause injury or death. Open and lock main disconnect and any other circuits before servicing unit.

Control Transformer - This changes the incoming power voltage to 110-120 volts for use by all unit control devices. Two primary and one secondary are provided. Refer to adjacent labeling for replacement information.

Terminal Strip - This provides connections for all 110-120 volt devices not contained within the enclosure.

Main Starter - This starter is used to provide control and overload protection for the main drive motor.

Standard full voltage starters employ a single contactor and overload protection for each motor. Overload heaters should be selected and adjusted based on the motor nameplate amps and the instructions located inside the control box door.

Changing Minimum Pressure/Check Valve Seals



DANGER

Air/oil pressure will cause severe personal injury or death. Shut down compressor, relieve system of all pressure, disconnect, lockout and tagout power supply to the starter before removing valves, caps, plugs, fittings, bolts and filters.

1. Be sure the unit is completely off and that no air pressure is in the oil reservoir.
2. Disconnect, lockout and tagout the power supply to the starter.
3. Tighten the nut down on the minimum pressure/check valve cover.
4. Remove the six (6) bolts holding the cover onto the separator housing.
5. Remove the snap ring in the cover.
6. Remove the internal parts (see Parts List Book) and replace the seals in the minimum pressure/check valve.

7. Re-assemble valve, including the snap ring.
8. Tighten the cover down to the separator housing.
9. Loosen the nut on top of the minimum pressure/check valve .05 to .08 inches.
10. Run the unit and check for leaks.

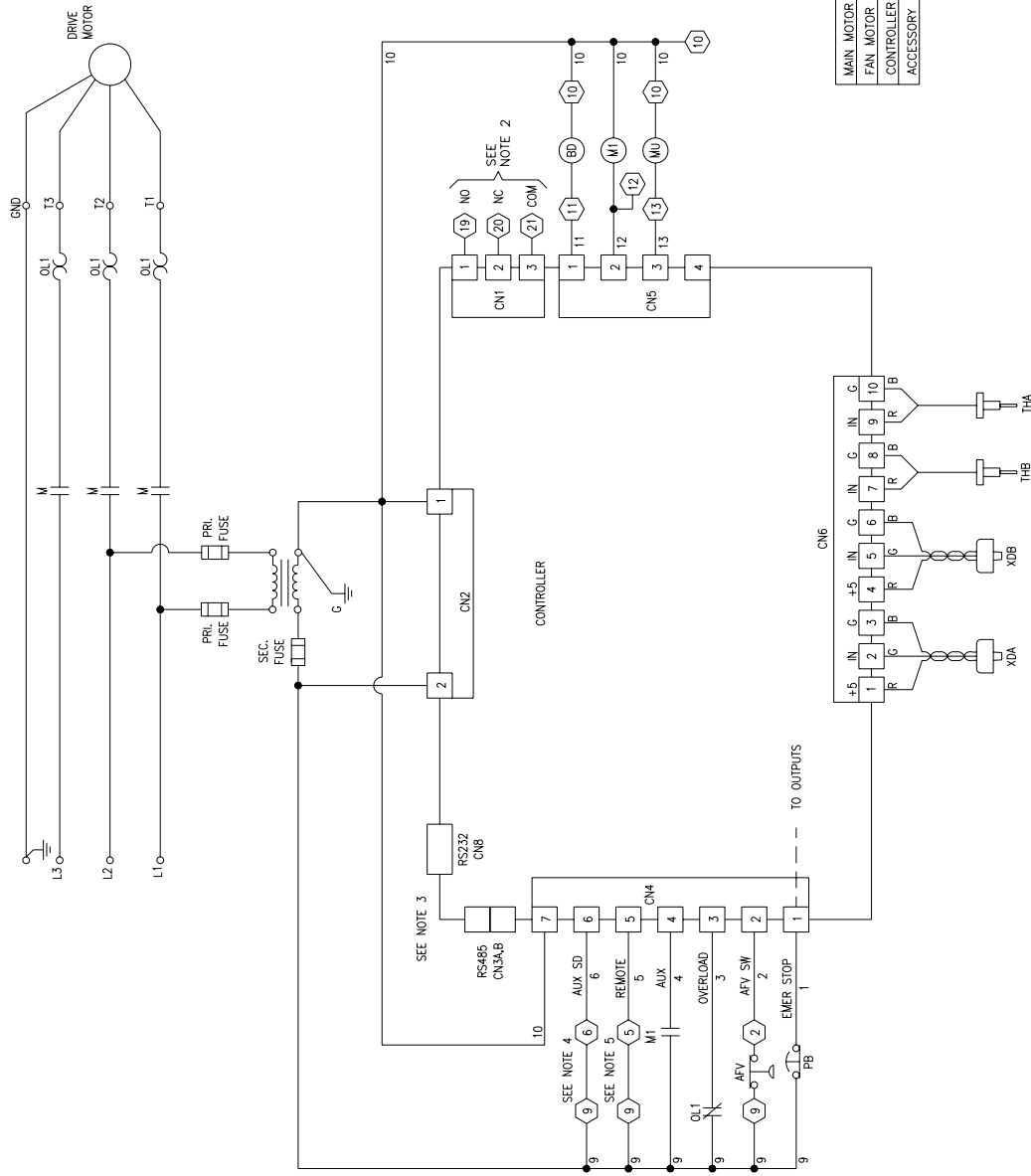

LEGEND:
 AFV -- AIR FILTER VACUUM SWITCH
 BD -- BLOWDOWN VALVE
 THA -- COMPRESSOR DISCHARGE THERMISTOR
 THB -- SEPARATOR THERMISTOR
 XDA -- SYSTEM PRESSURE TRANSDUCER
 XDB -- RESERVOIR PRESSURE TRANSDUCER
 MU -- MAGNETIC UNLOADER
 □ -- CONNECTION TO CONTROL BOARD
 ○ -- PANEL TERMINAL BLOCK

300EFC546-B
 (Ref. Drawing)
 Page 1 of 2

MAIN MOTOR	FV STARTER
FAN MOTOR	NONE
CONTROLLER	RS 2000
ACCESSORY	NONE

4-3 -- WIRING DIAGRAM

SECTION 5 LUBRICATION OIL COOLER, OIL FILTER & SEPARATOR

COMPRESSOR OIL SYSTEM (Figure 5-1) The compressor oil system cools the compressor, lubricates moving parts and seals internal clearances in the compression chamber.

Air pressure in the oil reservoir forces oil through the oil cooler, thermostatic mixing valve, oil filter and into the compressor main oil gallery.

The oil passes through internal passages for lubrication, cooling and sealing. The air-oil mixture is then discharged to the oil reservoir where a large part of the entrained oil drops out of the air stream. The remaining mixture then passes through the final oil separator where most of the remaining oil is removed. The air then passes to the aftercooler. The oil separated from the air is sent to the oil cooler and recirculated throughout the system. Oil separated at the air/oil separator is sent via an oil return line through an orifice and back into the compressor.

RECOMMENDED LUBRICANT - Gardner Denver compressors are factory filled with AEON lubricants. These lubricants are formulated to the highest quality standards and are factory authorized, tested and approved for use in rotary screw compressors. AEON lubricants are available through your authorized Gardner Denver compressor distributor.

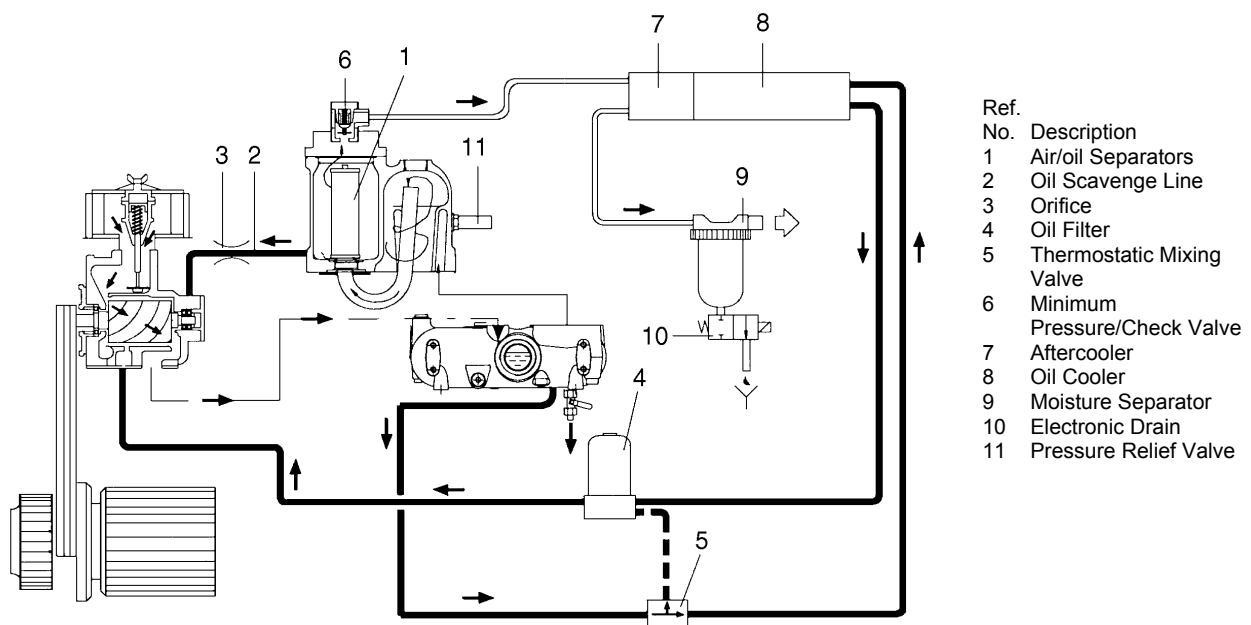

Figure 5-1 – FLOW DIAGRAM

OIL SPECIFICATIONS - The recommended compressor lubricant is Gardner Denver AEON 4000 Lubricating Coolant which can be used for year-round operation except as noted in the "High Temperature Operation" paragraph, page 25, or low temperature, see "Installation for Cold Weather Operation," page 10. AEON 4000 Lubricating Coolant is a superior petroleum base lubricant formulated and containing additives for use in Gardner Denver compressors.



CAUTION

Specific AEON™ lubricants are recommended for use in this equipment. Other lubricants may cause excessive carryover or compressor damage. Do not mix different types of lubricants or use inferior lubricants. Check the decal on the oil reservoir for lubricating coolant specification.

HIGH TEMPERATURE OPERATION - If the discharge temperature is sustained between 200-210° F. for a period of more than four (4) hours due to continuing high ambient air temperature, use Gardner Denver AEON 9000SP Lubricating Coolant which is a superior synthetic lubricant. Short periods of up to four (4) hours of sustained discharge temperatures up to 210° F. do not require a change from the recommended year-round lubricant AEON 4000.

COLD AMBIENT OPERATION - See "Installation for Cold Weather Operation," page 10 and Figure 2-3, page 9.

PROCEDURE FOR CHECKING OIL LEVEL (Figure 5-4, page 30) - Check the oil level when the compressor is shutdown and the oil/air mixture has separated. The oil should be visible between the min. and max. range, shown in Figure 5-4, page 30. If the oil level is above the max. range, the oil must be drained. If the oil level is below the min. range, oil must be added.

ADDITION OF OIL BETWEEN CHANGES - Oil must be added when the oil level is below the min. range on the oil gauge. The oil must be checked with the machine shutdown, blowdown and the air/oil mixture settled out to air and oil.



DANGER

Air/oil under pressure will cause severe personal injury or death. Shut down compressor, relieve system of all pressure, disconnect, lockout and tagout power supply to the starter before removing valves, caps, plugs, fittings, bolts and filters.



DANGER

Compressor, air/oil reservoir, separation chamber and all piping and tubing may be at high temperature during and after operation.



CAUTION

Excessive oil carryover can damage equipment. Never fill oil reservoir above the max. range of the gauge.

To add oil, follow these steps:

1. Be sure the unit is completely off and that no air pressure is in the oil reservoir.
2. Disconnect, lockout and tagout the power supply to the starter.

3. Wipe away all dirt around the oil filler plug. It is located by the oil filter.
4. Remove the oil filler plug and add oil as required to return the oil level to the max. line on the site glass.
5. Install the oil filler plug, run and check for leaks.

DO NOT OVERFILL. The quantity required to raise the oil level from the min. line to the max. line, (See Figure 5-4, page 30), is two (2) quarts (Figure 5-2, page 26). Repeated addition of oil between oil changes may indicate excessive oil carryover and should be investigated.

Use only CLEAN containers and funnels so no dirt enters the reservoir. Provide for clean storage of oils. Changing the oil will be of little benefit if done in a careless manner.

	20 to 30 HP (15 – 22 kW)
Refill Capacity For Normal Oil Change	2.00 U. S. Gallons (8.5 Liters)
Bottom of Site Glass to Top of Site Glass	2 U. S. Quart (2 Liters)

Figure 5-2 – APPROXIMATE OIL SYSTEM CAPACITIES

OIL CHANGE INTERVAL - Recommended oil change intervals are based on oil temperature. Figure 5-3, shows how the change interval is affected by temperature.

When operating conditions are severe (very dusty, high humidity, etc.), it will be necessary to change the oil more frequently. Operating conditions and the appearance of the drained oil must be surveyed and the oil change intervals planned accordingly by the user. Gardner Denver offers a free oil analysis program with the AEON lubricants and we recommend a sample be sent in at 100 hours on a new unit.

Discharge Temperature	AEON™ 4000 Change Interval	AEON™ 9000SP Change Interval
Up to 180° F (82° C)	4000 hrs.	8000 hrs.
180° F to 190° F (82° C to 88° C)	3000 hrs.	6000 hrs.
190° F to 200° F (88° C to 93° C)	2000 hrs.	4000 hrs.
200° F+ (93° C)	1000 hrs.	2000 hrs.

Figure 5-3 – OIL CHANGE INTERVAL

DRAINING AND CLEANING OIL SYSTEM



DANGER

Air/oil under pressure will cause severe personal injury or death. Shut down compressor, relieve system of all pressure, disconnect, lockout and tagout power supply to the starter before removing valves, caps, plugs, fittings, bolts and filters.

Always drain the complete system. Draining when the oil is hot will help to prevent varnish deposits and carry away impurities.

To drain the system:

1. Be sure the unit is completely off and that no air pressure is in the air/oil reservoir.
2. Disconnect, lockout and tagout the power supply to the starter.
3. Stick the end of the drain tube into a suitable container, such as a 5 gallon pail.
4. Open the drain valve and allow oil to drain out of the air/oil reservoir.
5. Close the drain valve.

If the drained oil and/or the oil filter element are contaminated with dirt, flush the entire system: the reservoir, oil cooler and lines. Inspect the air/oil separator element for dirt accumulation; replace if necessary. If a varnish deposit exists, contact the factory for recommendations for removal of the deposit and prevention of varnish.

FILLING OIL RESERVOIR



DANGER

Air/oil under pressure will cause severe personal injury or death. Shut down compressor, relieve system of all pressure, disconnect, lockout and tagout power supply to the starter before removing valves, caps, plugs, fittings, bolts and filters.



DANGER

Compressor, air/oil reservoir, separation chamber and all piping and tubing may be at high temperature during and after operation.

1. Be sure the unit is completely off and that no air pressure is in the oil reservoir.
2. Disconnect, lockout and tagout the power supply to the starter.

3. Wipe away all dirt around the oil filler plug.
4. Remove the oil filler plug and add oil as required to return the oil level to the max. range on the oil gauge.
5. Install the oil filler plug and operate the unit for about a minute allowing oil to fill all areas of the system. Check for leaks.
6. Shut down unit, allowing the oil to settle, and be certain all pressure is relieved.
7. Add oil, if necessary, to bring level to the max. range on the oil level gauge (Figure 5-4, page 30).

DO NOT OVERFILL as oil carryover will result. The quantity of oil required to raise the oil level from the min. range to the max range on the site glass is shown in Figure 5-2, page 26. Repeated addition of oil between oil changes may indicate excessive oil carryover and should be investigated.

Use only CLEAN containers and funnels so no dirt enters the reservoir. Provide for clean storage of oils. Changing the oil will be of little benefit if done in a careless manner.



CAUTION

Excessive oil carryover can damage equipment. Never fill oil reservoir above the top of the site glass.

LUBRICANT UPGRADE PROCEDURE - Upgrading to a longer life lubricant is essentially a very worthwhile practice. The following are the primary steps to be completed when upgrading or changing the type of lubricant.



CAUTION

Improper equipment maintenance with use of synthetic lubricants will damage equipment. Oil filter and oil separator change intervals remain the same as for AEON 4000 -- See Maintenance Schedule, Page 40 .



DANGER

Air/oil under pressure will cause severe personal injury or death. Shut down compressor, relieve system of all pressure, disconnect, lockout and tagout power supply to the starter before removing valves, caps, plugs, fittings, bolts and filters.



WARNING

High temperature operation can cause damage to equipment or personal injury. Do not repeatedly restart the unit after high temperature stops operation. Find and correct the malfunction before resuming operation.



WARNING

All materials used in Gardner Denver® compressor units are compatible with AEON 9000SP Lubricating Coolant. Use caution when selecting downstream components such as air line lubricating bowls, gaskets and valve trim.

AEON 9000SP Synthetic Lubricant is not compatible with low nitrile Buna N or acrylic paints. AEON 9000SP is compatible with most air system downstream components.

1. Be sure the unit is completely off and that no air pressure is in the air/oil reservoir.
2. Disconnect, tag and lock out the power supply to the starter.
3. Thoroughly drain system:
 - Drain oil from airend and cooler while hot.
 - Break low point connections and drain oil from pipe runs.
 - Dump Oil from filter and reinstall used filter.
4. Fill system with a 50 percent charge of the new lubricant:
 - Start the machine and stay there to observe.
 - Allow the machine to run about five minutes at temperature, or until temperature stabilizes, then shut down
5. Thoroughly drain machine.
6. Change to a new filter and separator.
7. Fill system with a full charge of the new lubricant.
8. Machine should then be run normally; however, total run time after the initial changeouts should be 50 percent of normal anticipated service life of the new lubricant.
 - Drain all lubricant from system, change filter and separator, and replace with full charge of the new lubricant.
9. Subsequent lubricant changeouts should be at normal intervals. (See “Oil Change Interval” and chart, page 26.

Material Safety Data Sheets (MSDS) are available for all AEON lubricants from your authorized Gardner Denver distributor or by calling (901) 542-6100.

OIL LEVEL GAUGE (Figure 5-4, page 30) - The oil level gauge indicates the amount of oil in the air/oil reservoir. Read oil level only when the unit is shut down and the air/oil mixture has separated. Add oil only when the oil level is below the min. range on the site glass. Drain oil only when the oil level is above the max. range on the site glass.

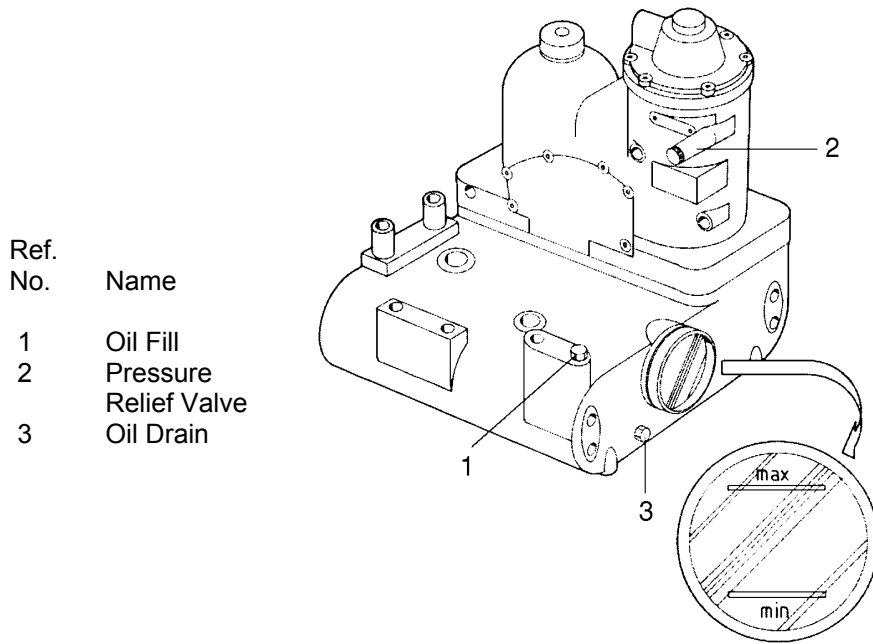



Figure 5-4 – OIL LEVEL GAUGE, OIL FILL AND OIL DRAIN

MOISTURE IN THE OIL SYSTEM - In normal humidity and with normal operating temperatures and pressures, the thermal mixing valve controls the oil temperature and prevents moisture contamination of the oil. Unusual cooling of the oil reservoir, short loaded cycle in high humidity or malfunctions of the thermal valve may result in moisture in the oil system which is detrimental to compressor lubrication and could cause oil carryover. If moisture is observed in the oil reservoir, drain the moisture and correct the condition causing the accumulation.

See “Compressor Oil System Check”, page 34 and “Thermal Control Valve”, page 32.

COMPRESSOR OIL FILTER (Figure 1-2, page 2 and Figure 5-5, page 31) - This replaceable element filter is a vital part in maintaining a trouble-free compressor, since it removes dirt and abrasives from the circulated oil.

	<h2>CAUTION</h2>
<p>Improper oil filter maintenance will cause damage to equipment. Replace filter element every 1000 hours of operation. More frequent replacement could be required depending on operating conditions. A filter element left in service too long may damage equipment.</p>	

Use only the replacement element shown on the filter tag or refer to the parts list for the part number. Use the following procedure to replace the filter element. Do not disturb the piping.



DANGER

Air/oil under pressure will cause severe personal injury or death. Shut down compressor, relieve system of all pressure, disconnect, lockout and tagout power supply to the starter before removing valves, caps, plugs, fittings, bolts and filters.



DANGER

Compressor, air/oil reservoir, separation chamber and all piping and tubing may be at high temperature during and after operation.

1. Stop unit and be sure no air pressure is in the oil reservoir.
2. Disconnect, tag and lock out the power supply to the starter.
3. Remove the spin-on element.
4. Clean the gasket face of the filter body.
5. Coat the new element gasket with clean lubricant used in the unit.
6. Screw new element on filter body and tighten clockwise by hand 3/4 turn after contact. **DO NOT OVERTIGHTEN ELEMENT.**
7. Reset the filter life setting to 1000 hours, see "Maintenance Adjustments" in Controller Operating and Service Manual.
8. Run the unit and check for leaks.

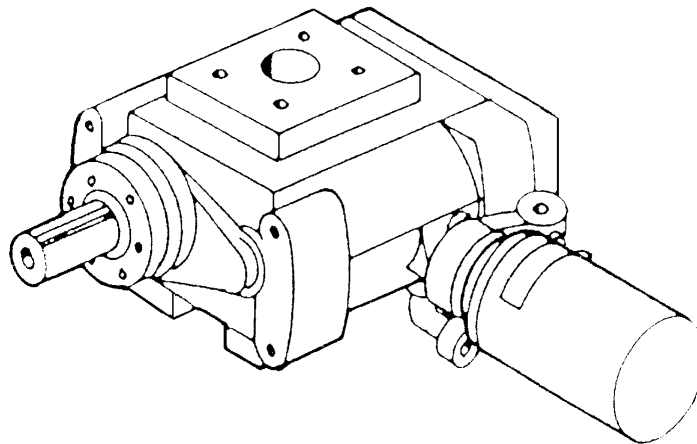

Figure 5-5 – OIL FILTER

COMPRESSOR OIL COOLER - The cooler fan is mounted on the compressor motor shaft; air is exhausted through the oil cooler and away from the unit. Do not obstruct air flow to and from the oil cooler. Allow a minimum of two (2) feet (.6M) clearance around the cooler. Keep both faces of the cooler core clean for efficient cooling of compressor oil.

THERMAL CONTROL (THERMOSTATIC MIXING) VALVE (Figure 5-1 page 24) - is installed in the system. This valve is used to control the temperature of the oil. On start-up with unit cold, the element is open to bypass, allowing oil to pass directly from the reservoir to the compressor during warm-up. As oil warms, the element gradually closes to the bypass allowing more of the oil from the cooler to mix with oil from the bypass.

After the unit is warmed up, the mixing valve maintains oil injection temperature into the compressor at a minimum of 150° F (66° C). This system provides proper compressor warm-up and prevents moisture contamination of the oil.

To check the element, heat it in oil - it should be fully extended at 150° F (66° C). If the unit shuts down due to high air discharge temperature, the cause may be that the element is stuck open to the bypass. When flushing the oil system, remove the mixing valve and clean all parts thoroughly.

OIL RESERVOIR - The oil reservoir-separator combines multiple functions into one vessel. The lower half is the oil reservoir, providing oil storage capacity for the system and the top portion, a primary oil separation means. The reservoir also provides limited air storage for control and gauge actuation.

COMPRESSOR AIR/OIL SEPARATOR (Figure 5-6, page 34) - Located in a separate housing, consists of a renewable cartridge-type separator element and provides the final removal of oil from the air stream.

Oil impinging on the inside of the separator element drains directly back into the oil reservoir by gravity. Oil collected outside the element is returned through tubing to the compressor cylinder.

Oil carryover through the service lines may be caused by a faulty oil separator, overfilling of the oil reservoir, oil that foams, oil return line malfunction, or water condensate in the oil. If oil carryover occurs, inspect the separator only after it is determined that the oil level is not too high, the oil is not foaming excessively, the oil return tube from the bottom of the separator to the compressor cylinder is not clogged or pinched off, the check valve in the oil return is functioning properly, and there is not water or an oil/water emulsion in the oil.

Oil carryover malfunctions of the oil separator are usually due to using elements too long, heavy dirt or varnish deposits caused by inadequate air filter service, use of improper oil, or using oil too long for existing conditions. Excessive tilt angle of the unit will also hamper separation and cause oil carryover.

Oil separator element life cannot be predicted; it will vary greatly depending on the conditions of operation, the quality of the oil used and the maintenance of the oil and air filters. The condition of the separator can be determined by pressure differential or by inspection.

Pressure Differential Gauging – The “CHANGE SEPARATOR” advisory will flash when the pressure differential across the oil separator reaches approximately 8 PSID (.55 Bar). Replace the oil separator element at this time. If ignored, the unit will shutdown and the advisory will illuminate steadily when the pressure differential reaches 15 PSID (1 Bar).



CAUTION

Using an oil separator element at excessive pressure differential can cause damage to equipment. Replace the separator when the differential pressure is greater than 8 psi or every 4,000 hours (at least once a year).

NOTICE

A sudden drop of zero pressure differential or sudden heavy oil carryover may indicate a ruptured element.

Inspection - After removal of separator element, shine a light inside the element to reveal areas of heavy dirt or varnish deposits or breaks (ruptures) in element media.

Removal of Oil Separator For Inspection or Replacement:



DANGER

Air/oil under pressure will cause severe personal injury or death. Shut down compressor, relieve system of all pressure, disconnect, lockout and tagout power supply to the starter before removing valves, caps, plugs, fittings, bolts and filters.



DANGER

Compressor, air/oil reservoir, separation chamber and all piping and tubing may be at high temperature during and after operation.

1. Be certain the unit is off and that no air pressure is in the oil reservoir. The compressor package will automatically blowdown in about 2 minutes.
2. Close the air service valve located after the compressor package discharge.
3. Disconnect, lockout and tagout the power supply to the starter.
4. Remove the minimum pressure/check valve, see Item 1, Figure 5-6, page 34 (air/oil separator housing) cover.
5. Lift out the air/oil separator element. See Item 2, Figure 5-6, page 34.
6. Inspect and/or replace the separator as necessary.
7. Clean the sealing surfaces on the air/oil separator and the minimum pressure/check valve.
8. Clean the orifice, Item 3, Figure 5-6, page 34, in the oil return line, the strainer, Item 4, Figure 5-6, page 34, in the oil return line, and if necessary, the air/oil separator housing.
9. Grease the O-Ring on the separator element and install the separator into the housing.
10. Replace the O-Ring, Item 5, Figure 5-6, page 34, between the minimum pressure/check valve and the air/oil separator housing.
11. Replace the sealing kit in the minimum pressure/check valve. After the assembling of the valve, leave about .08 inch gap between the nut, Item 6, Figure 5-6, page 34, and the cover of the valve. See "Changing Minimum Pressure/Check Valve Seals," Section 4, page 20.

12. Install the minimum pressure/check valve assembly and tighten the bolts alternately for even tightness.
13. Open the air service valve.
14. Run the unit and check for leaks.

COMPRESSOR OIL SYSTEM CHECK - The following readings are based on ambient temperature of 80° F (27° C) with the system in good condition. The compressor should be at operating temperature at the time of the checks. One-half hour of loaded operation is usually sufficient to reach level-out operating temperatures.

Air and Oil Discharge Temperature - 160° F to 180° F (71° C to 82° C) - Check with a thermometer at the discharge housing.

Compressor Oil Inlet Temperature - 150° F to 165° F (66° C to 74° C) - Install a tee at the oil filter outlet and check with a thermometer.

Oil Inlet Pressure - Check at the fitting in the line near the compressor oil inlet. With air receiver pressure at 100 psi (6.9 Bar), oil inlet pressure should be 80 to 90 psig (5.5 to 6.2 Bar).

Oil Cooler Oil Pressure Differential (Air-Cooled Radiator) - Check differential across the oil system by measuring oil inlet pressure as described above.

Oil Cooler Temperature Differential (Air-Cooled Radiator) - The oil temperature differential depends on the temperature of the air at the oil cooler fan and cleanliness of the core faces. As ambient temperatures and core restrictions increase, the oil cooler outlet temperature will increase. The oil inlet temperature is approximately the same as the air discharge temperature.

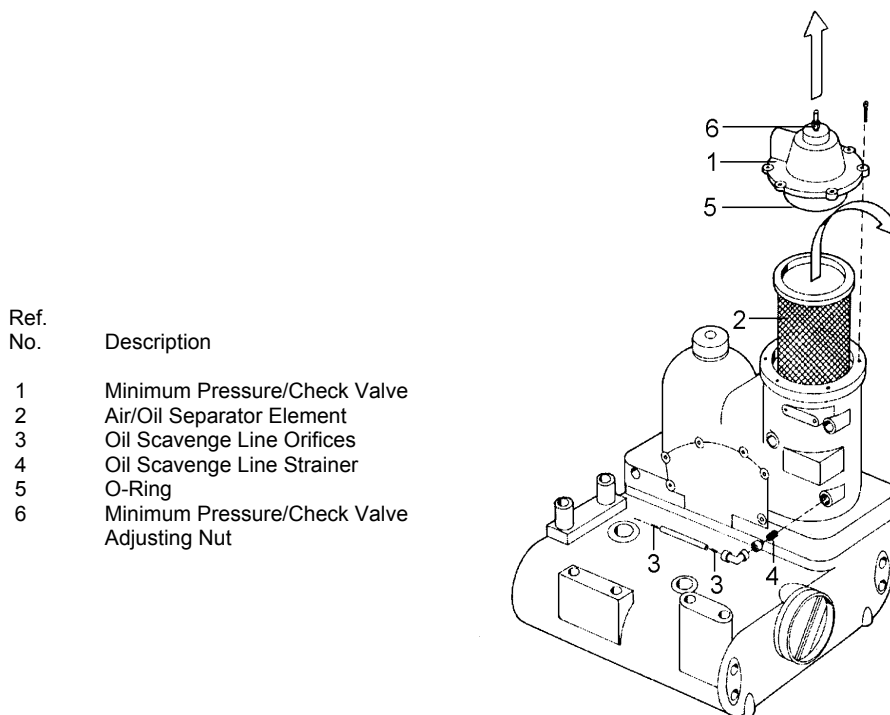

Figure 5-6 – OIL SEPARATOR

SECTION 6 AIR FILTER

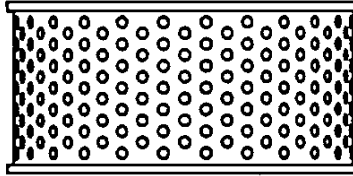

Figure 6-1 – AIR FILTER

STANDARD DUTY AIR FILTER (Figure 6-1) - Replacement instructions are given in the following sections:



DANGER

Compressor, air/oil reservoir, separation chamber and all piping and tubing may be at high temperature during and after operation.



WARNING

The air filter element can not be cleaned or reused.

Filter Element - The element should be replaced when inspection indicates an accumulation of dirt on the outside of the element. Inspect every few days until experience determines the proper time interval for servicing.

To Service:

1. Be certain the unit is off and that no air pressure is in the air/oil reservoir. The compressor package will automatically blow down in about 2 minutes.
2. Close the air service valve located after the compressor package discharge.
3. Disconnect, lockout and tagout the power supply to the starter.
4. Remove the air filter cover (Figure 6-1).
5. Clean the inside of the air filter housing.
6. Install new air filter element and the air filter cover.
7. Open the air service valve.

Filter Element Life - The element should be replaced if visual inspection indicates an accumulation of dirt, or a rupture, crack or pin holes in the pleated media. Inspection should be done by placing a bright light inside the element.



WARNING

Do not oil this element. Never operate unit without element. Never use elements that are damaged or ruptured. Never use elements that won't seal. Keep spare elements on hand to reduce downtime. Store elements in a protected area free from damage, dirt and moisture. Handle filter parts with care.

SECTION 7

BELT DRIVE

Proper drive belt tension and alignment are provided at the factory, however, good practice dictates checking the drive alignment and tension after shipment and before initial start-up.

Sheaves should align straight across the front with a straight edge. The best tension is just enough tension to keep belts from “squealing” on start-up.



CAUTION

Excessive belt tension can damage the equipment. Tension the belts as shown in Figure 7-1, page 39.

REPLACING THE COMPRESSOR BELTS

1. Disconnect, lockout and tagout the power supply to the starter.
2. Remove the belt guards.
3. Using adjusting screws, jack the motor base up to loosen the belt tension. Remove the belts.
4. Install new belts, tighten belts using the adjust screws. Check for correct belt tension.
5. Check sheave alignment. (See “SHEAVE ALIGNMENT”).
6. Assemble the guards.

SHEAVE ALIGNMENT

The sheave alignment and belt tightening system consists of a hinged plate for the motor which is supported between (2) posts and a slotted platform for the Tempest units. To achieve proper sheave alignment the sheaves must be adjusted for both parallel and angular alignment. The alignment between the motor and air-end sheaves should be confirmed with the use of a straight edge. If the sheaves are properly aligned, the straight edge should touch the two outer edges of each sheave for a total of four points of contact. Gaps between the outer edges of either of the sheaves and the straight edge indicate sheave misalignment.

The airend sheave is set in the parallel and angular direction by mounting it on the air-end shaft that is part of the Tempest unit that is bolted to the platform. The platform has been set in the parallel and angular directions by its inherent design. The motor sheave is set in the parallel direction by sliding it on the motor shaft to position it in line with the airend sheave. (Check for alignment with straight edge.)

Note: It may be necessary to loosen the Tempest unit and slide it in the platform mounting slots to keep the motor sheave fan blades in the correct position in the cooler orifice ring.

The motor sheave is set in the angular direction by means of (2) jack bolts and the hinged plate. To start the angular alignment process check to make sure the locking nuts on the jack bolts are loose. The motor sheave can be aligned in the angular direction to the same plane as the airend sheave by turning down the jack bolts on one side or the other of the hinged plate. (Check for alignment with straight edge.) It also may be necessary to use the nuts that are on the jack bolts to push up on one side or the other of the hinged plate. **Note:** At this point it may also be necessary to make minor adjustments of the position of the sheave on the motor shaft to get proper alignment. Once proper alignment has been obtained, lock

the sheave in place on the motor shaft; then the jack bolt lock nuts must be tightened. One set of nuts is tightened down against the base to lock the jack bolts in place. The second set is locked down to sandwich the hinged plate against the jack bolt heads. When lock nuts are in place, a final alignment check should be made with the straight edge.

Note: Any of the following actions will require the sheave alignment be checked and any or all of the above steps repeated. (Initial start up at customer site, compressor change, motor change, unit relocation, or when the belts are replaced.)

It's important to note that the belts should not be over tightened. To check belt tension use a Gardner Denver Belt Tension Gauge, Part Number 00543217. V-belt tension will drop after the first 8-24 hrs of unit run time. Failure to check and re-tension the belts after the initial run-in period will result in belt slippage and premature belt failure. Please see Figure 7-1, page 39, for proper belt tension.



CAUTION

Interference between the fan and the orifice can damage equipment. Be certain the orifice has even clearance around the fan before starting the unit.

REPLACING THE COMPRESSOR SHEAVE

1. Disconnect, lockout and tagout the power supply to the starter.
2. Remove the guards.
3. Using the adjusting screws, jack the motor base up to loosen the belt tension, Remove the belts.
4. Remove bolts from tapered bushing.
5. Pull the sheave off the rotor shaft with a gear puller, if necessary.
6. Install new sheave and tapered bushing.
7. Install new belts. Check for correct belt tension and reattach the wire guard.
8. Align sheaves with a straight edge. (See "SHEAVE ALIGNMENT", page 37).
9. Assemble the guards.

CHECKING BELT TENSION - Using a spring scale, apply a perpendicular force to each belt at the midpoint of the span and measure the deflection. Correct deflection force and deflection are shown in Figure 7-1. To tighten belts, merely increase the center distance.

NOTICE

When a new set of belts is installed on a drive, the initial deflection force should be 1/3 greater than shown in Figure 7-1. Recheck tension frequently during the first 24 hours of operation

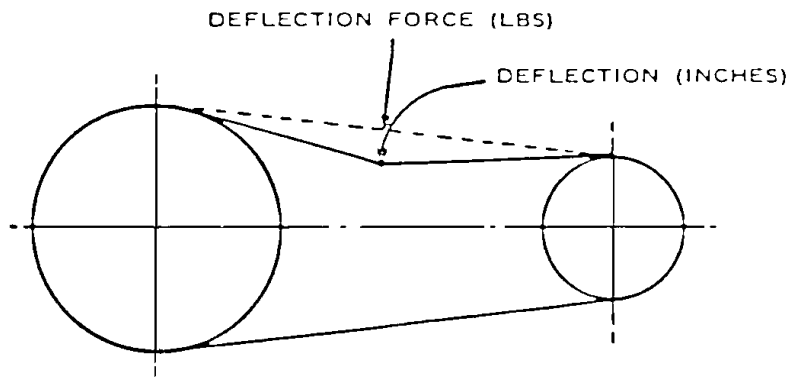

Motor H.P.	No. of Belts	Deflection Force Pounds	Deflection In Inches
20	4	6 – 8.5	3/8
25	4	6 – 8.5	3/8
30	4	6 – 8.5	3/8

Figure 7-1 – BELT TENSION – J SECTION MICRO-V BELTS

SECTION 8 MAINTENANCE SCHEDULE

SERVICE CHECK LIST –

Air Filter - Operating conditions determine frequency of service. See “Air Filter,” SECTION 6, page 35.

Motor Lubrication - Refer to SECTION 2, page 12.

Every 8 Hours Operation

1. Check the reservoir oil level - add oil if required. See SECTION 5, page 24. If oil consumption is high, refer to “Excessive Oil Consumption,” page 43.
2. Observe if the unit loads and unloads properly.
3. Check discharge pressure and temperature.

Every 125 Hours Operation

1. Check for dirt accumulation on oil/aftercooler core faces and the cooling fan. If cleaning is required, clean the exterior fin surfaces of the cores by blowing compressed air carrying a nonflammable safety solvent in a direction opposite that of the cooling fan air flow. This cleaning operation will keep the exterior cooling surfaces clean and ensure effective heat dissipation.

Every 1000 Hours Operation

1. Change oil filter element.

Every 4000 Hours Operation

1. Change the compressor lubricant. UNDER ADVERSE CONDITIONS, CHANGE MORE FREQUENTLY (refer to “Oil Change Interval”, Figure 5-3, page 26). Flush system if required.

Every Year

1. Check the relief valve for proper operation. See Section 4, page 17.
2. Change oil separator, see “Removal of Oil Separator for Inspection or Replacment”, Section 5, page 24, for further details (or when 8 psid pressure differential across the element).

MAINTENANCE SCHEDULE (See Detail Notes above)

Maintenance Action	As Indicated by RS2000 Controller	Every 8 Hours	Every 125 Hours	Every 1000 Hours	Every 4000 Hours	Every Year
Check/Change Air Filter	•					
Change Oil Separator	•					•
Check Reservoir Oil Level **		•				
Check for Proper Load/Unload		•				
Check Dirt Accumulation on Cooler			•			
Change Oil Filter Element & Clean Oil Return Strainer				•		
Change Compressor Lubricant (AEON 4000) *					•	
Check Relief Valve						•
Check Condition of Hoses					•	•
Check Operation of Condensate Removal Solenoid Valve		•				
Change Inlet Valve Seals						•

* See "Oil Change Interval Chart", Figure 5-3, page 26, for specific lubricant life.

** Must be checked when the compressor is stopped and the air/oil mixture is separated.

SECTION 9 TROUBLESHOOTING

SYMPTOM	POSSIBLE CAUSE	REMEDY
Compressor fails to start	1. Wrong lead connections.	1. Change leads.
	2. Blown fuses in control box.	2. Replace fuse.
	3. Motor starter overload heaters tripped .	3. Reset and investigate cause of overload.
	4. Pressure in reservoir.	4. Inspect blowdown valve.
	5. Emergency stop depressed.	5. Release button.
Compressor starts but stops after a short time	1. High discharge temperature.	1. See "High Discharge Air Temperature," this section.
	2. High separator/ high compressor temperature light on.	2. See "High Discharge Air Temperature", this section.
	3. Blown fuse in starter/ control box.	3. Replace fuse (investigate if fuses continue to blow).
	4. Motor starter overload heaters trip.	4. Reset and investigate cause of overload.
Compressor does not unload (or load)	1. Improperly adjusted control.	1. Refer to SECTION 4, page 17 and adjust control.
	2. Air leak in control lines.	2. Determine source of leak and correct.
	3. Restricted control line.	3. Clean control lines.
	4. Faulty inlet valve solenoid.	4. Replace solenoid valve.
Compressor cycles from load to unload excessively	1. Insufficient receiver capacity.	1. Increase receiver size.
	2. Restriction in service piping.	2. Inspect and clean service piping.
	3. Restriction in control tubing.	3. Inspect and clean control tubing.
	4. Plugged aftercooler.	4. Inspect and clean aftercooler.
Compressor runs unloaded too often	1. Volume of compressed air system too small.	1. Check the volume of the piping and air receivers. An additional air receiver may be required.
	2. Pressure range too narrow.	2. Extend pressure range.

SYMPTOM	POSSIBLE CAUSE	REMEDY
Compressor starts too slowly	1. Wye Delta switch time set too long.	1. Contact your Gardner Denver distributor.
	2. Minimum Pressure/Check Valve is faulty.	2. Repair or replace.
	3. Supply voltage is too low.	3. Check the supply voltage.
Compressor is low on delivery and pressure	1. Restricted air filter.	1. Clean or replace filter.
	2. Sticking inlet valve.	2. Inspect and clean inlet valve.
	3. Minimum pressure valve stuck closed.	3. Replace valve.
	4. Oil separator clogged.	4. Replace.
	5. Intervals of moisture separator drainage incorrectly set.	5. Check the setting in the Air Pilot controller.
	6. Condensate drain solenoid valve is faulty.	6. Replace.
	7. Leaks in the compressed air system.	7. Check for leaks, fix any leaks found.
	8. V-Belts broken.	8. Replace.
	9. V-Belts slipping.	9. Test belt tensioning.
	10. Pressure limits incorrectly set.	10. Check/correct pressure limits in the RS2000 Controller.
	11. Aftercooler is frozen	11. Thaw out. This machine cannot operate in temperatures below 32° F (0° C).
High discharge air temperature	1. Dirty or clogged cooler face.	1. Clean cooler.
	2. Insufficient cooling air flow.	2. Provide unrestricted supply of cooling air.
	3. Clogged oil filter or cooler (interior).	3. Replace filter or clean cooler.
	4. Low compressor oil.	4. Add oil to proper level.
	5. Faulty temperature sensor.	5. Replace sensor.
	6. Thermostatic mixing valve stuck open.	6. Repair or replace valve.
Excessive oil consumption	1. Oil carryover through lines.	1. See "Oil Carryover", in this section.
	2. Oil leaks at all fittings and gaskets.	2. Tighten or replace fittings or gaskets.

SYMPTOM	POSSIBLE CAUSE	REMEDY
Oil carryover	3. Shaft seal leaking.	3. Replace shaft seal.
	1. Overfilling the reservoir.	1. Drain excess oil from system.
	2. Clogged, broken or loose oil return lines.	2. Tighten or replace faulty lines.
	3. Ruptured oil separator element.	3. Replace element.
	4. Loose assembly.	4. Tighten all fittings and gaskets.
	5. Foam caused by use of incorrect oil.	5. Use Gardner Denver AEON 2000, 4000 or 9000SP lubricating coolant.
	6. Inoperative minimum pressure valve.	6. Replace seals in valve.
	7. Operation at elevated discharge temperatures.	7. Reduce temperature. See "High Discharge Air Temperature", this section.
	8. Scavenge line check valve failure.	8. Replace check valve.
9. Water condensate in oil.	9. Check oil reservoir temperature and if low, change thermal mixing valve element to higher temperature.	



DANGER

Air/oil under pressure will cause severe personal injury or death. Shut down compressor, relieve system of all pressure, disconnect, lockout and tagout power supply to the starter before removing valves, caps, plugs, fittings, bolts and filters

TROUBLESHOOTING VOLTAGE PROBLEMS

The compressor package has been designed, built, and tested to operate within one of the following standard ranges:

200-208 Volts, 60 Hertz

230-240 Volts, 60 Hertz

460-480 Volts, 60 Hertz

575-600 Volts, 60 Hertz

Connection to higher voltages will reduce the life of electrical devices within the compressor package. As voltages get further above the design range, other symptoms may show up.

High voltages may lead to high motor currents. The overload relay will sense these and shut down the compressor to protect the motor.

If the control transformer primary fuses blow, check that the transformer is properly connected for the incoming line voltage.

Operation with lower voltages will reduce motor life and load capacity. As voltages get further below the design range, other symptoms may show up.

Low voltages may lead to high motor currents. The overload relay will sense these and shut down the compressor to protect the motor. If voltage is low while the compressor is off, locate and correct the cause. If the voltage drops low only while the compressor is running, look for poor connections or undersized wiring.

If any of the starters or contactors within the box chatter, or if the electronic controller drops out while attempting to start, it is a clear indication that the wiring is inadequate for the compressor. Look for poor connections or undersized wiring.

NOTICE

Gardner Denver factory remanufactured replacement compressor airend units are available from your authorized distributor, on an exchange basis, for all rotary screw compressor units.

GENERAL PROVISIONS AND LIMITATIONS

Gardner Denver (the "Company") warrants to each original retail purchaser ("Purchaser") of its new products from the Company or its authorized distributor that such products are, at the time of delivery to the Purchaser, made with good material and workmanship. No warranty is made with respect to:

1. Any product which has been repaired or altered in such a way, in the Company's judgment, as to affect the product adversely.
2. Any product which has, in the Company's judgment been subject to negligence, accident, improper storage, or improper installation or application.
3. Any product which has not been operated or maintained in accordance with the recommendations of the Company.
4. Components or accessories manufactured, warranted and/or serviced by others.
5. Any reconditioned or prior owned product.

Claims for items described in (4) above should be submitted directly to the manufacturer.

WARRANTY PERIOD

The Company's obligation under this warranty is limited to repairing or, at its option, replacing, during normal business hours at an authorized service facility of the Company, and part which in its judgment proved not to be as warranted within the applicable Warranty Period as follows.

AIRENDS

Airends, consisting of all parts within and including the cylinder and gear housing, are warranted for 24 months from date of initial use or 27 months from date of shipment to the purchaser, whichever occurs first.

Any disassembly or partial disassembly of the airend, or failure to return the "unopened" airend per Company instructions, will be cause for denial of warranty.

MAJOR PACKAGE COMPONENTS

Air or water cooled coolers and the RS2000 Controllers are warranted for 24 months from date of initial use or 27 months from date of shipment to the first purchaser, whichever occurs first, as provided in, and subject to the terms of the original component manufacturer's warranty.

DRIVE AND FAN MOTOR

The drive and fan motor (if applicable) are warranted for 60 months from start-up or 63 months from shipment, whichever occurs first. The warranty is applicable only to Toshiba low voltage motors (600 Volts or less). High voltage motors and other manufacturer motors furnished due to customer request or special requirements carry the motor manufacturer's warranty.

OTHER COMPONENTS

All other components are warranted for 12 months from date of initial use or 15 months from date of shipment to first purchaser, whichever occurs first.

LABOR TRANSPORTATION AND INSPECTION

The Company will provide labor, by Company representative or authorized service personnel, for repair or replacement of any product or part thereof which in the Company's judgment is proved not to be as warranted. Labor shall be limited to the amount specified in the Company's labor rate schedule.

Labor costs in excess of the Company rate schedule amounts or labor provided by unauthorized service personnel is not provided for by this warranty.

All costs of transportation of product, labor or parts claimed not to be as warranted and, of repaired or replacement parts to or from such service facilities shall be borne by the Purchaser. The Company may require the return of any part claimed not to be as warranted to one of its facilities as designated by Company, transportation prepaid by Purchaser, to establish a claim under this warranty.

Replacement parts provided under the terms of the warranty are warranted for the remainder of the Warranty Period of the product upon which installed to the same extent as if such parts were original components.

DISCLAIMER

THE FOREGOING WARRANTY IS EXCLUSIVE AND IT IS EXPRESSLY AGREED THAT, EXCEPT AS TO TITLE, THE COMPANY MAKES NO OTHER WARRANTIES AND HEREBY EXPRESSLY DISCLAIMS ALL OTHER WARRANTIES, INCLUDING WITHOUT LIMITATION, EXPRESSED, IMPLIED OR STATUTORY WARRANTIES, INCLUDING ANY IMPLIED WARRANTY OF MERCHANTABILITY OR FITNESS FOR A PARTICULAR USE.

THE REMEDY PROVIDED UNDER THIS WARRANTY SHALL BE THE SOLE, EXCLUSIVE AND ONLY REMEDY AVAILABLE TO PURCHASER AND IN NO CASE SHALL THE COMPANY BE SUBJECT TO ANY OTHER OBLIGATIONS OR LIABILITIES. UNDER NO CIRCUMSTANCES SHALL THE COMPANY BE LIABLE FOR SPECIAL, INDIRECT, INCIDENTAL OR CONSEQUENTIAL DAMAGES, EXPENSES, LOSSES OR DELAYS HOWSOEVER CAUSED.

NO STATEMENT, REPRESENTATION, AGREEMENT, OR UNDERSTANDING, ORAL OR WRITTEN, MADE BY ANY AGENT, DISTRIBUTOR, REPRESENTATIVE, OR EMPLOYEE OF THE COMPANY WHICH IS NOT CONTAINED IN THIS WARRANTY WILL BE BINDING UPON THE COMPANY UNLESS MADE IN WRITING AND EXECUTED BY AN OFFICER OF THE COMPANY.

THIS WARRANTY SHALL NOT BE EFFECTIVE AS TO ANY CLAIM WHICH IS NOT PRESENTED WITHIN 30 DAYS AFTER THE DATE UPON WHICH THE PRODUCT IS CLAIMED NOT TO HAVE BEEN AS WARRANTED. ANY ACTION FOR BREACH OF THIS WARRANTY MUST BE COMMENCED WITHIN ONE YEAR AFTER THE DATE UPON WHICH THE CAUSE OF ACTION OCCURRED.

ANY ADJUSTMENT MADE PURSUANT TO THIS WARRANTY SHALL NOT BE CONSTRUED AS AN ADMISSION BY THE COMPANY THAT ANY PRODUCT WAS NOT AS WARRANTED.

Gardner --- **Denver**

Specifications subject to change without notice.

Copyright © 2004 Gardner Denver, Inc.

Litho in U.S.A.

<http://www.gardnerdenver.com>

mktg@gardnerdenver.com

For additional information contact your local representative or



Gardner Denver Compressor and Pump Division,
1800 Gardner Expressway, Quincy, Illinois 62301
Customer Service Department Telephone:
(800) 682-9868 FAX: (217) 224-7814

Sales and Service in all major cities.

For parts information, contact Gardner Denver,
Master Distribution Center, Memphis, TN
Telephone: (800) 245-4946 FAX: (901) 542-6159