CHAMPION®

13-8-518
Version: 11
March 9, 2007

**ROTORCHAMP
BASE-MOUNTED
COMPRESSOR**

MODELS -- EFD99A

40 & 50 HP

PARTS LIST

CHAMPION®
A Gardner Denver Product

**MAINTAIN COMPRESSOR RELIABILITY AND PERFORMANCE WITH
GENUINE CHAMPION® COMPRESSOR PARTS AND SUPPORT SERVICES**

Champion® Compressor genuine parts, manufactured to design tolerances, are developed for optimum dependability – specifically for Champion compressor systems. Design and material innovations are the result of years of experience with hundreds of different compressor applications. Reliability in materials and quality assurance is incorporated in our genuine replacement parts.

Your authorized Champion Compressor distributor offers all the backup you'll need. A worldwide network of authorized distributors provides the finest product support in the air compressor industry.

Your authorized distributor can support your Champion air compressor with these services:

1. Trained parts specialists to assist you in selecting the correct replacement parts.
2. Factory warranted new and remanufactured rotary screw airends. Most popular model remanufactured airends are maintained in stock at the Remanufacturing Center in Indianapolis, IN., for purchase on an exchange basis with liberal core credit available for the replacement unit.
3. A full line of factory tested RotorLub™ compressor lubricants specifically formulated for use in Champion compressors.
4. Repair and maintenance kits designed with the necessary parts to simplify servicing your compressor.

Authorized distributor service technicians are factory trained and skilled in compressor maintenance and repair. They are ready to respond and assist you by providing fast, expert maintenance and repair services.

For the location of your local authorized Champion Air Compressor distributor, refer to the yellow pages of your phone directory, check the Gardner Denver Web Site at www.Championpneumatic.com or contact:

Factory:
Champion
1301 N. Euclid Ave.
Princeton, IL. 61356

Phone: (815) 875-3321

Fax: (815) 872-0421

INSTRUCTIONS FOR ORDERING REPAIR PARTS

When ordering parts, specify Compressor MODEL, Method of Cooling, HORSEPOWER and SERIAL NUMBER (see nameplate on unit). The Airend Serial Number is also stamped on top of the discharge bearing carrier casting.

All orders for Parts should be placed with the nearest authorized distributor.

Where NOT specified, quantity of parts required per compressor or unit is one (1); where more than one is required per unit, quantity is indicated in parenthesis. SPECIFY EXACTLY THE NUMBER OF PARTS REQUIRED.

DO NOT ORDER BY SETS OR GROUPS.

To determine the Right-Hand and Left-Hand side of a compressor, stand at the motor end and look toward the compressor. Right-Hand and Left-Hand are indicated in parenthesis following the part name, i.e. (RH) and (LH), when appropriate.

TOTAL PRODUCT SUPPORT – CHAMPION’S CONTINUING COMMITMENT TO YOUR AIR COMPRESSOR PERFORMANCE

Commitment to total product support continues long after the purchase of your quality Champion rotary screw compressor.

Champion original parts incorporate years of experience and improvements in design, materials and quality assurance. Maintaining your compressor investment with Champion parts will insure protection for the air compressor unit and long, dependable service life.

Your authorized Champion compressor distributor maintains a complete stock of all common maintenance parts, factory approved Rotorlub lubricants, and Champion factory warranted exchange airends. In addition, authorized distributor technicians are factory trained, and can provide complete diagnostic, compressor maintenance and repair services.

This manual is designed to assist you in maintaining high performance and receiving many years of dependable service you expect from your Champion compressor.

REMANUFACTURED AIRENDS

Whenever an airend requires replacement or repair, Champion offers an industry unique, factory remanufactured airend exchange program. From its modern Remanufacturing Center in Indianapolis, IN., Champion is committed to supplying you with the highest quality, factory remanufactured airends that are guaranteed to save you time and money.

Immediately Available

Repair downtime costs you money, which is why the most popular models are in inventory at all times, ready for immediate delivery.

Skilled Craftsmen

Our Remanufacturing assembly technicians average over 20 years experience with air compression products.

Precision Remanufacturing

All potentially usable parts are thoroughly cleaned, inspected and analyzed. Only those parts that can be brought back to original factory specifications are remanufactured. Every remanufactured airend receives a new overhaul kit: bearings, gears, seals, sleeves and gaskets.

Extensive Testing

Champion performs testing that repair houses just don't do. Magnaflux and ultrasonic inspection spot cracked or stressed castings, monochromatic light analysis exposes oil leaks, and coordinate measurement machine inspects to +/- .0001", insuring that all remanufactured airends meet factory performance specifications.

Warranty

Champion backs up every remanufactured airend with a warranty...27 months from purchase or 24 months from start-up.

Champion remanufactured airends deliver *quality without question...year in and year out.*

Call Champion for information on the airend exchange program and the name of your authorized distributor.

Phone Number: 815-875-3321 or
Fax: 815-872-0421

TABLE OF CONTENTS

Maintain Compressor Reliability And Performance With Genuine Champion Compressor Parts And Support Services.....	1
Instructions For Ordering Repair Parts	1
Total Product Support – Champion’s Continuing Commitment To Your Air Compressor Performance.....	2
Remanufactured Airends	2
Bare Compressor	4
Airend Repair Kits	4
Airend Group.....	5, 6
Inlet Valve Repair Parts	7, 8
Minimum Pressure/Check Valve	9, 10
Airend And Inlet Filter Assembly.....	11, 12
Base And Mounting Group.....	13, 14
Cooler And Piping	15, 16
Drive Groups – 40 HP ODP	17, 18
Drive Groups – 50 HP ODP & TEFC	19, 20
Drive Groups – 40 HP TEFC.....	21, 22
Enclosure Group	23, 24
Quiet Baffle	25, 26
Control Piping.....	27, 28
Group Identification And Instruction.....	29
Decal & Fuse Group.....	30
Controller Assembly – Full Voltage Starter – 40 & 50 HP	31, 32
Controller Assembly – Wye Delta Starter – 40 & 50 HP	33, 34
Controller Assembly – Less Main Motor Starter	35, 36
Controller Assembly	37
Controller Assembly - Board	38
Main Motor (Full Voltage And Wye Delta).....	39
Overload Relay Heater Conversion Listing.....	40
Repair Kits.....	41

For Operating and Service Instructions, See:

SERVICE MANUAL	13-8-627
AUTO SENTRY CONTROL	13-8-624

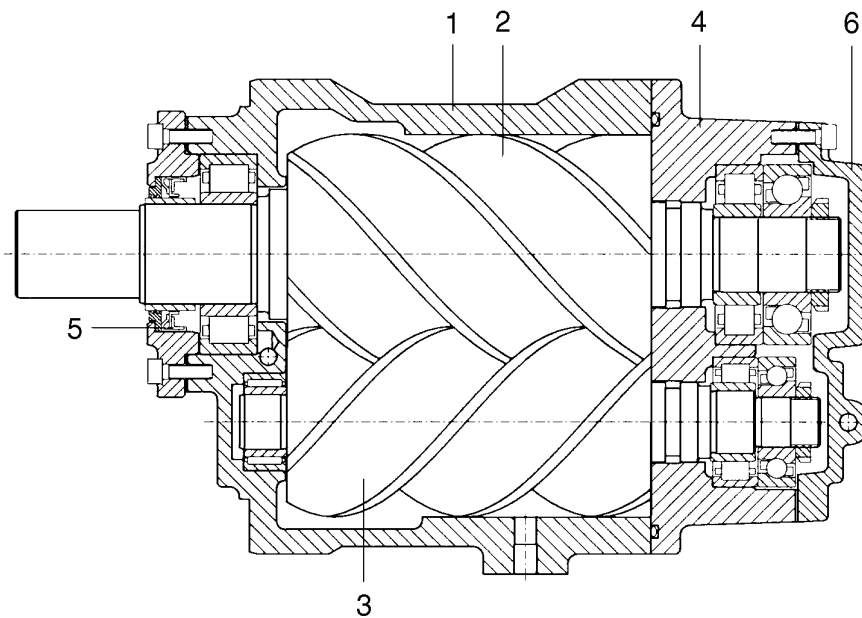

BARE COMPRESSOR

Ref. No.	Name of Part
----------	--------------

1	CYLINDER
2	MAIN ROTOR
3	SECONDARY ROTOR
4	DISCHARGE BEARING HOUSING
5	DRIVE SHAFT SEAL
6	DISCHARGE END PLATE

For Replacement Airend, order Part Number 306EFD6013. See Page 42.

For Periodic Overhaul Kit, order Part Number 307EFD6013. See Page 42.

AIREND REPAIR KITS

Model	HP	PSI	Replacement Airend Kit	Bearing Kit *	Inlet Valve Kit	Drive Shaft Seal Kit	T12 Overhaul & Repair Tool Kit
EFD	40-50	100-175	306EFD6013	307EFD6013	302EFD6013	300EFD6029	305EFD6013

* Bearing Kits include Gasket Kit and Drive Shaft Seal Kit.

For listing of Repair Parts included in Kit numbers above, see Repair Kit Section, pages 40-41.

AIREND GROUP

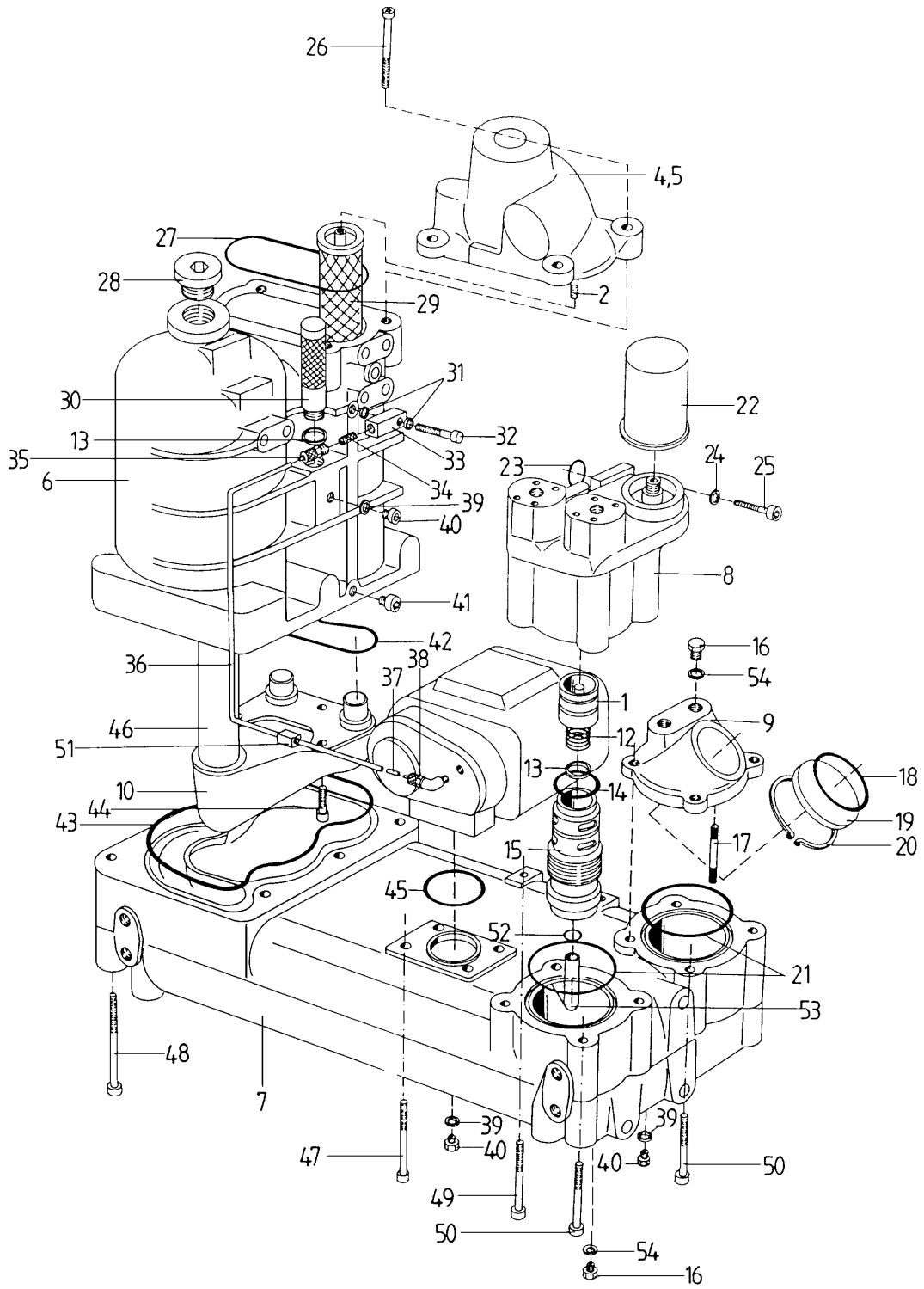

Order by Part Number and Description. Reference Numbers are for your convenience only.

AIREND GROUP

B/M: EFC03979732

Ref. No.	Name of Part	Qty.	Part No.
1	THERMOSTAT ELEMENT		
	150° Standard	1	EFC89560169
	180° Optional	1	EFC89626099
2	STUD.....	2	EFC30899728
4	MINIMUM PRESSURE/CHECK VALVE ASSEMBLY.....	1	EFC37609908
5	MINIMUM PRESSURE/CHECK VALVE HOUSING	1	EFC03979868
6	SEPARATOR HOUSING	1	EFC03979171
7	OIL SUMP/BASE.....	1	EFC03979041
8	FILTERSTAT HOUSING.....	1	EFC03979601
9	OIL SITE GAGE HOUSING	1	EFC03812268
10	AIR SEPARATION CHAMBER	1	EFC03812398
12	SPRING.....	1	EFC89565369
13	GASKET.....	2	EFC28335250
14	O-RING	1	EFC89560299
15	SUCTION TUBE.....	1	EFC37607328
16	PLUG.....	3	EFC03381178
17	OIL SITE GLASS MEASURING ROD.....	1	EFC30899608
18	O-RING	1	EFC89573939
19	OIL SITE GLASS.....	1	EFC30899578
20	RETAINING RING.....	1	EFC42227570
21	O-RING	2	EFC86906369
22	OIL FILTER.....	1	2117916
23	O-RING	1	EFC89565109
24	LOCKWASHER	2	EFC80015909
25	SCREW	2	EFC44580140
26	SCREW	4	EFC89563199
27	O-RING	1	EFC89562879
28	PLUG.....	1	EFC85328079
29	OIL SEPARATOR	2	2117908
30	PRESSURE RELIEF VALVE	1	EFC89728559
31	GASKET.....	2	EFC80314109
32	SCREW.....	1	EFC89569309
33	CONNECTOR	1	EFC30909408
* 34	OIL SCAVENGE LINE SCREEN	1	EFC85588619
35	CONNECTOR	1	EFC03398578
36	PLASTIC TUBE.....	1	EFC85200299
37	ORIFICE.....	1	EFC30895408
38	ELBOW	1	EFC85267219
39	GASKET.....	3	EFC80098799
40	PLUG.....	3	EFC81606709
41	PLUG.....	1	EFC80704779
42	O-RING	1	EFC89562749
43	O-RING	1	EFC89562909
44	SCREW	3	EFC44578470
45	O-RING	1	EFC89558369
46	AIR SEPARATION SHOTGUN	1	EFC03493258
47	SCREW	1	EFC89542539
48	SCREW	6	EFC87465429
49	SCREW.....	2	EFC89558519
50	SCREW	8	EFC89558649
* 51	CHECK VALVE	1	EFC87340549
52	O-RING	1	EFC89534789
53	OIL TUBE.....	1	EFC37624508
54	GASKET.....	3	EFC80034799

* Parts included in Pneumatic Control Kit Part Number 312EFD6013. Refer to page 42

INLET VALVE REPAIR PARTS

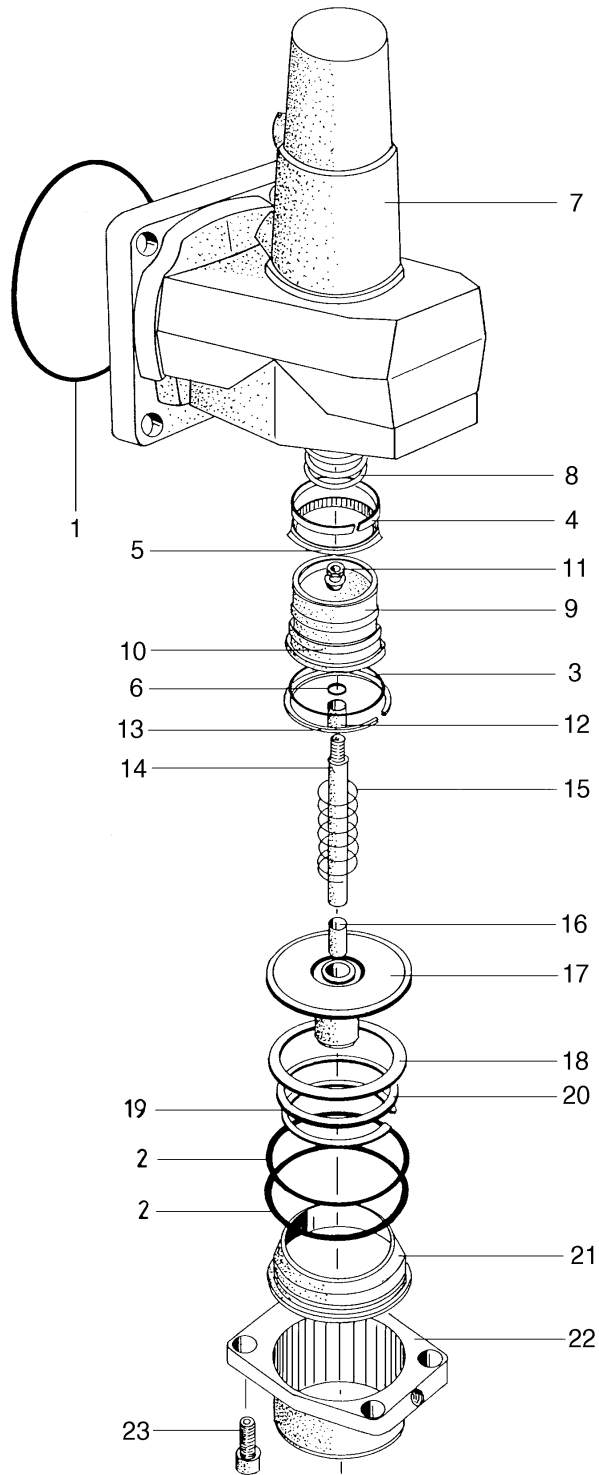

Order by Part Number and Description. Reference Numbers are for your convenience only.

INLET VALVE REPAIR PARTS

Ref.			
No.	Name of Part	Qty.	Part No.
	INLET VALVE ASSEMBLY		EFC22330248
	INLET VALVE SEAL KIT (ITEMS 1-6, 18, 19)		EFC30816408
	INLET VALVE REPAIR KIT (ITEMS 1-6, 10, 12, 15, 16, 18, 19).		EFC89555469
1	O-RING	1	
2	O-RING	2	
3	O-RING	1	
4	RING	1	
5	PISTON GASKET	1	
6	O-RING	1	
7	FRAME	1	
8	SPRING	1	
9	PISTON	1	
10	COVER	1	
11	NUT	1	
12	BEARING BUSHING	1	
13	LOCK RING	1	
14	PISTON ROD	1	
15	SPRING	1	
16	BEARING BUSHING	1	
17	PLATE	1	
18	GASKET	1	
19	STOP RING	1	
20	RING	1	
21	BUSHING	1	
22	FLANGE	1	
23	SCREW	4	

MINIMUM PRESSURE/CHECK VALVE

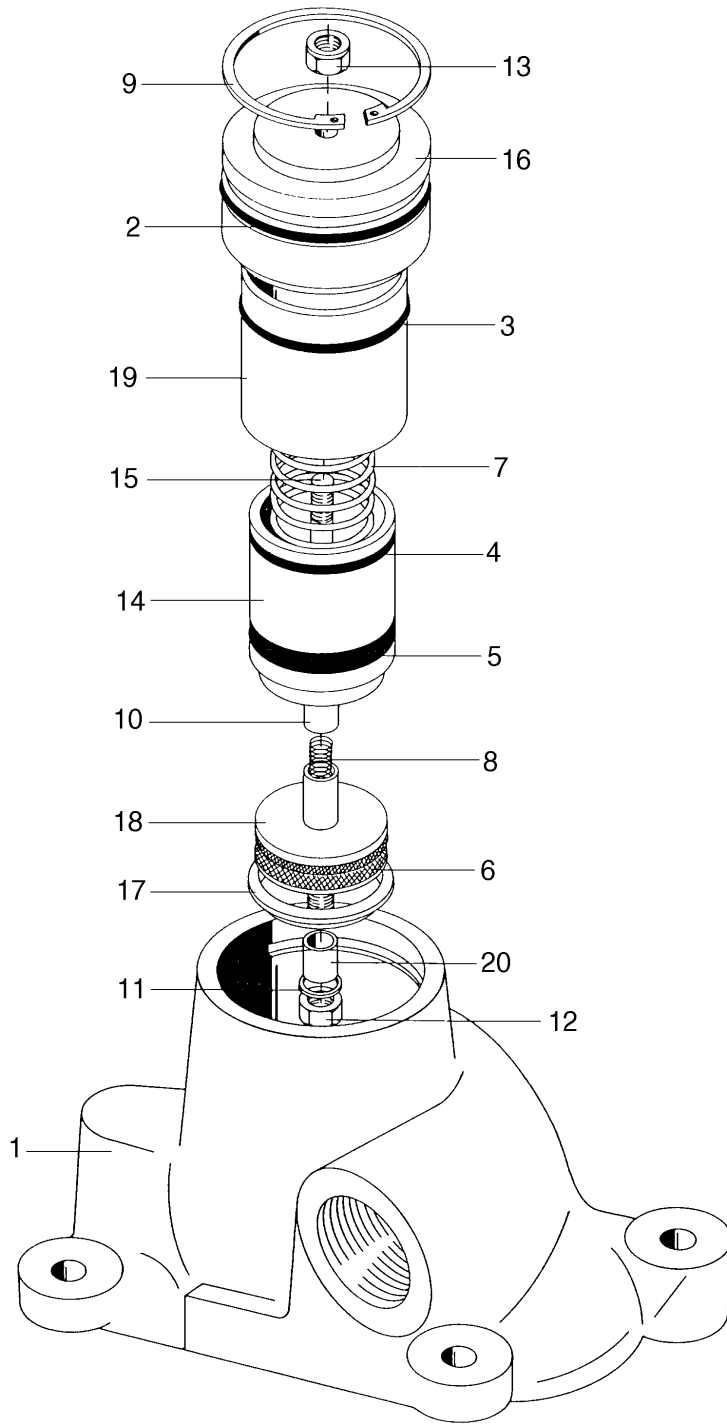

Order by Part Number and Description. Reference Numbers are for your convenience only.

MINIMUM PRESSURE/CHECK VALVE

Ref. No.	Name of Part	Qty.	Part No.
1	MINIMUM PRESSURE/CHECK VALVE HOUSING	1	EFC03979868
	MINIMUM PRESSURE/CHECK VALVE ASSEMBLY KIT (Includes Reference Numbers 2-20)	1	EFC37609908
	MINIMUM PRESSURE/CHECK VALVE SEAL KIT (Includes Reference Numbers 2, 4, 5, 6 & 8)	1	EFC89573249
	MINIMUM PRESSURE/CHECK VALVE REPAIR KIT (Includes Reference Numbers 2 & 4-14)	1	EFC89573379
2	O-RING	1	
3	O-RING	1	
4	PISTON SEAL	1	
5	PACKING RING	1	
6	GASKET	1	
7	SPRING	1	
8	SPRING	1	
9	RETAINING RING	1	
10	BUSHING (BEARING)	1	
11	GASKET	1	
12	NUT	1	
13	NUT	1	
14	PISTON	1	
15	SCREW	1	
16	COVER	1	
17	RING, THRUST	1	
18	PLATE	1	
19	SLEEVE	1	
20	BUSHING	1	

AIREND AND INLET FILTER ASSEMBLY

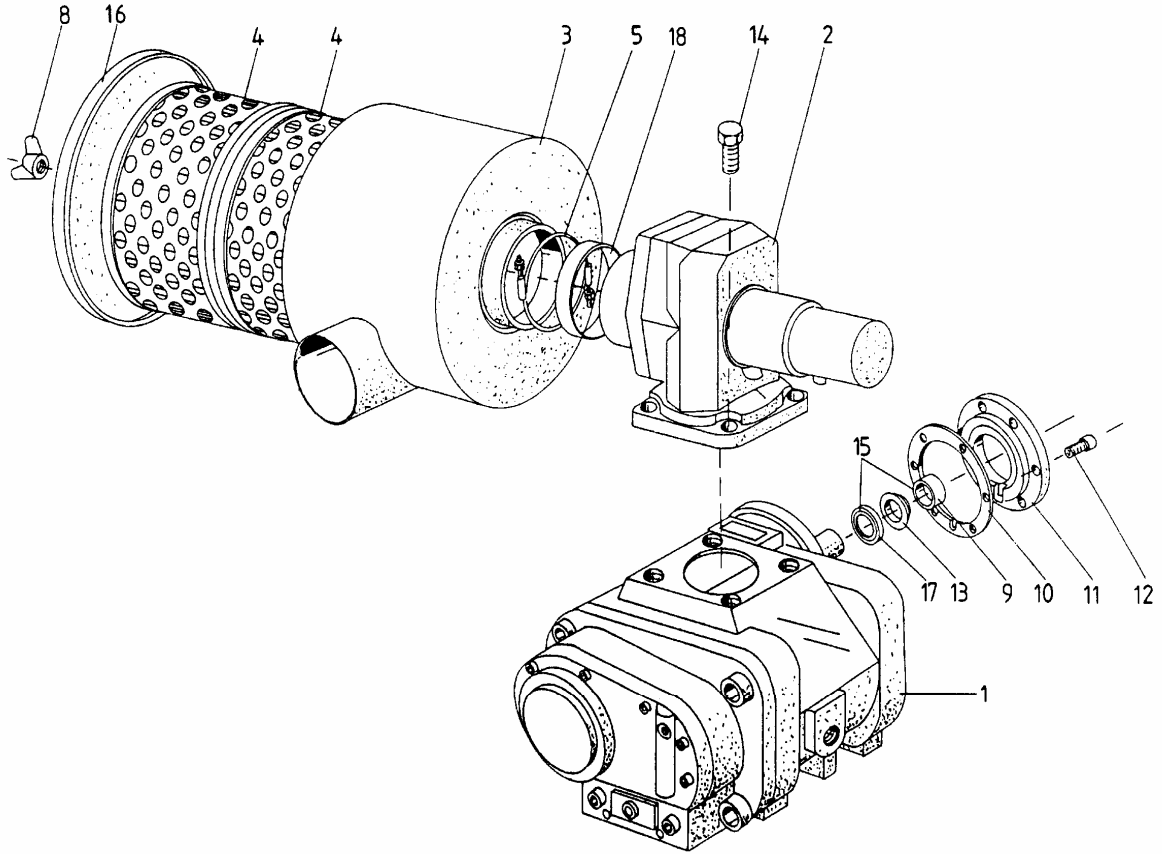

Order by Part Number and Description. Reference Numbers are for your convenience only.

AIREND AND INLET FILTER ASSEMBLY

**B/M: 300EFD4017
SEFC04019024**

Ref. No.	Name of Part	Qty.	Part No.
1	AIREND (Includes Reference Numbers 9-13, 15 & 17)...	1	SEFC04019024
2	INTAKE VALVE ASSEMBLY.....	1	EFC22330248
3	AIR FILTER HOUSING	1	EFC22329998
4	AIR FILTER	2	2117910
5	CLAMP	1	EFC87905389
8	WING NUT.....	1	EFC80220059
9	BEARING INNER RACE	1	EFC87089639
* 10	GASKET, AIREND SEAL HOUSING	1	EFC30805908
11	HOUSING, AIREND SEAL	1	EFC03786718
12	SCREW	6	EFC44611040
13	SPACER.....	1	EFC30806218
14	SCREW	4	EFC44585470
* 15	SHAFT SEAL REPAIR KIT (Includes Items 9 & 17)	1	EFC30834028
16	COVER.....	1	EFC22330098
17	SHAFT SEAL.....	1	EFC85850159
18	GASKET	1	EFC30861088
19	SUCTION TUBE (not shown).....	1	EFC30819018
20	SCREW (not shown)	4	EFC80242159
21	NUT (not shown).....	4	EFC80177459

* Parts included in Seal Kit Part Number 300EFD6029. Refer to page 41.

Order by Part Number and Description. Reference Numbers are for your convenience only.

BASE AND MOUNTING GROUP

B/M: 302EFD4017
B/M: 300EFD4013

Ref. No.	Name of Part	Qty.	Part No.
1	BASE	1	300EFD285
2	SUPPORT	1	300EFD165
3	LEG	2	300EFD1263
4	LEG	2	301EFD1263
5	PEDESTAL	1	300EFD1296
6	SCREW	1	655EG560
7	WASHER	2	95A8
8	NUT	2	50B8
9	NUT	20	50AW5
10	SCREW	24	75K48
11	WASHER	4	95A5
12	WASHER	4	95C1
13	WASHER	4	95W49
15	NUT	4	50AW35
16	SCREW	2	75AA101
17	LOCKWASHER	6	95B5
18	SCREW	4	665HMCA120300
19	ORIFICE	1	300EFD814

COOLER AND PIPING

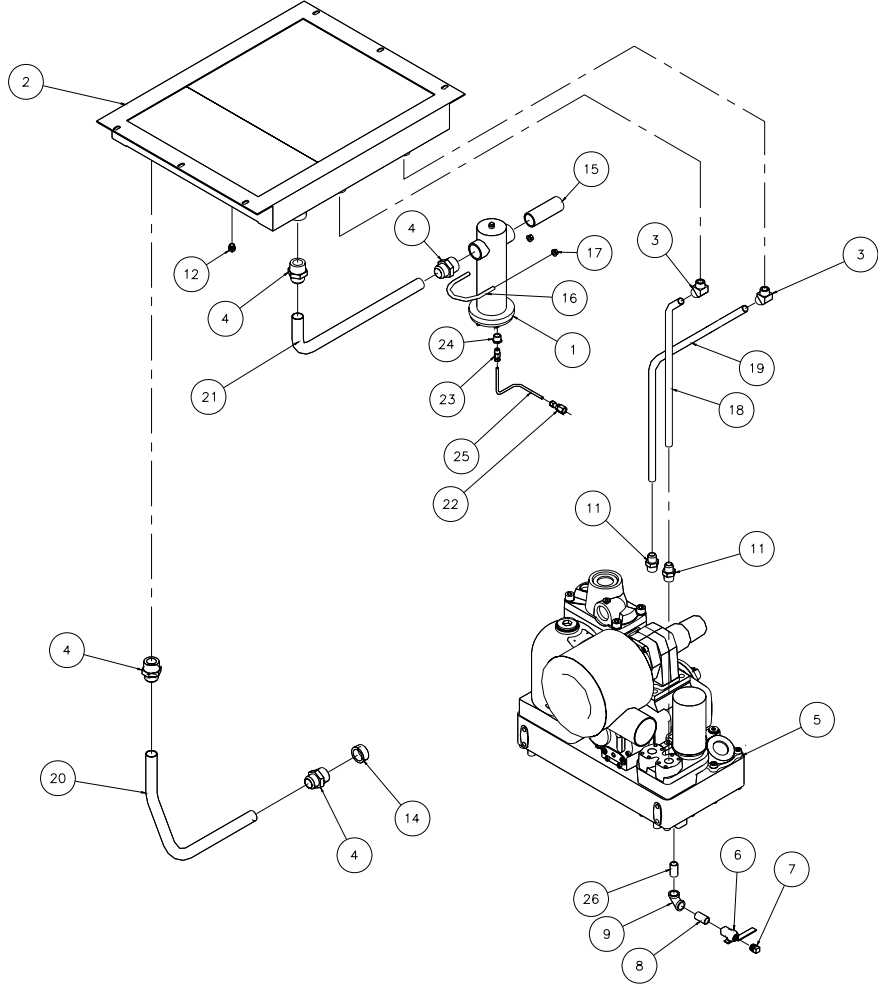

301EFD810-H
(Ref. Drawing)

Order by Part Number and Description. Reference Numbers are for your convenience only.

COOLER AND PIPING

B/M: 300EFD4019

Ref. No.	Name of Part	Qty.	Part No.
1	TRAP	1	83C83
2	COOLER-OIL/AIR RADIATOR.....	1	300EFD201
3	ADAPTER	2	305EFD863
4	CONNECTOR-TUBE.....	4	86H140
5	AIREND	1	EFC50380121
6	VALVE-BALL	1	90AR360
7	PLUG	1	64AA7
8	NIPPLE.....	1	63F1G
9	PLUG	1	64C4G
11	CONNECTOR-TUBE.....	2	86H149
12	PLUG	1	64AA4
14	BUSHING	1	86H158
15	NIPPLE.....	1	63J7G
16	U-BOLT.....	1	143742
17	NUT	2	50AW5
18	HOSE	1	306EFD127
19	HOSE	1	305EFD127
20	HOSE.....	1	308EFD127
21	TUBE WITH FITTINGS	1	303EFD863
22	CONNECTOR	1	86N343
23	CONNECTOR	1	86E4
24	BUSHING-PIPE	1	64E2G
25	TUBE-BULK (IN FEET)	1	85K3
26	NIPPLE.....	1	86H154

DRIVE GROUPS – 40 HP ODP

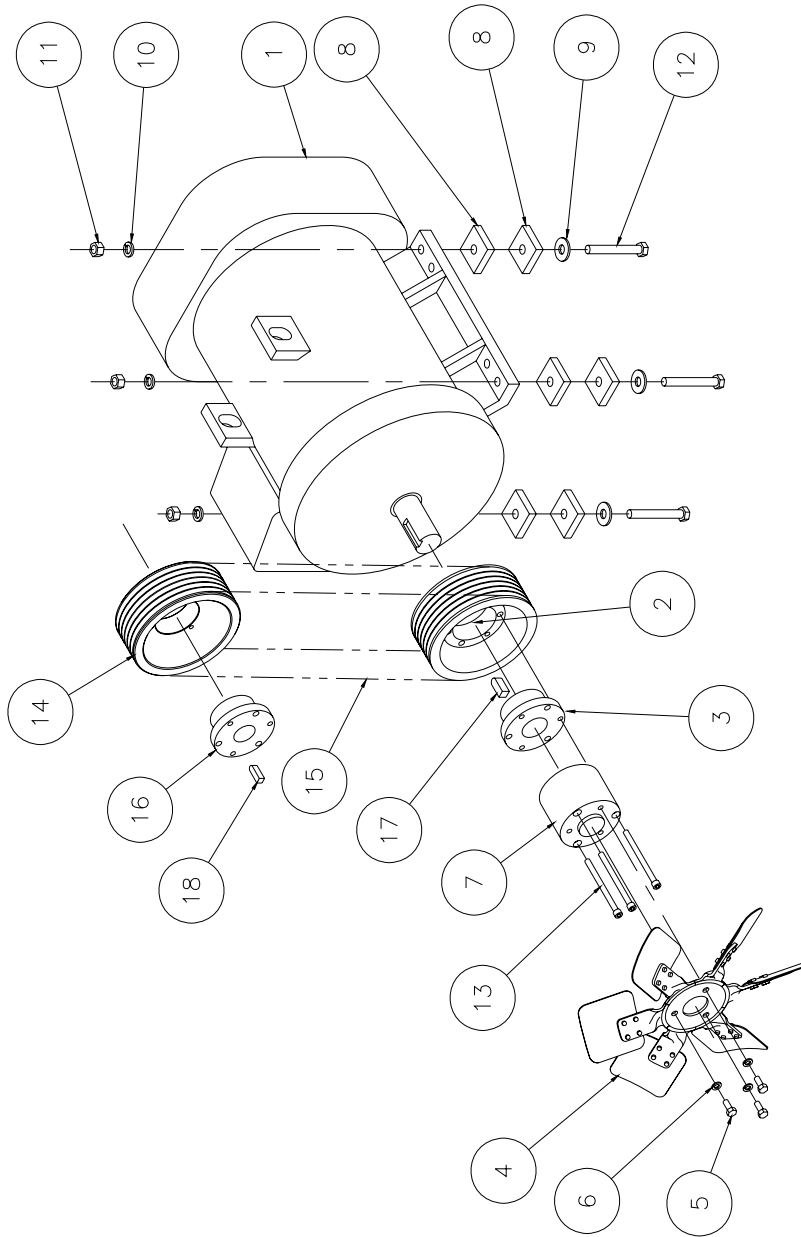

303EFD810-C
(Ref. Drawing)

Order by Part Number and Description. Reference Numbers are for your convenience only.

DRIVE GROUPS – 40 HP ODP

Ref. No.	Name of Part	Qty.	100 PSIG B/M: 348EFD4004 Part No.	125 PSIG B/M: 349EFD4004 Part No.	150 PSIG B/M: 350EFD4004 Part No.	175 PSIG B/M: 351EFD4004 Part No.
1	MAIN MOTOR	--	See page 39	See page 39	See page 39	See page 39
2	SHEAVE	1	300EFD099	300EFD099	300EFD099	300EFD099
3	BUSHING	1	22F26SK	22F26SK	22F26SK	22F26SK
4	FAN	1	300EFD701	300EFD701	300EFD701	300EFD701
5	SCREW	3	75A33	75A33	75A33	75A33
6	LOCKWASHER	3	95B2	95B2	95B2	95B2
7	SPACER	1	301EFD144	301EFD144	301EFD144	301EFD144
8	SHIM	8	300EFD732	300EFD732	300EFD732	300EFD732
9	WASHER	4	95A5	95A5	95A5	95A5
10	LOCKWASHER	4	95B5	95B5	95B5	95B5
11	NUT	4	50B5	50B5	50B5	50B5
12	SCREW	4	655EE120	655EE120	655EE120	655EE120
13	SCREW	3	75P203	75P203	75P203	75P203
14	SHEAVE	1	304EFD099	307EFD099	311EFD099	312EFD099
15	SET-BELT	1	13AJ6006	13AJ6306	13AJ6306	13AG6306
16	BUSHING	1	22J23	22J23	22J23	22J23
17	KEY	1	35L89	35L89	35L89	35L89
18	KEY	1	35L74	35L74	35L74	35L74

DRIVE GROUPS – 50 HP ODP & TEFC

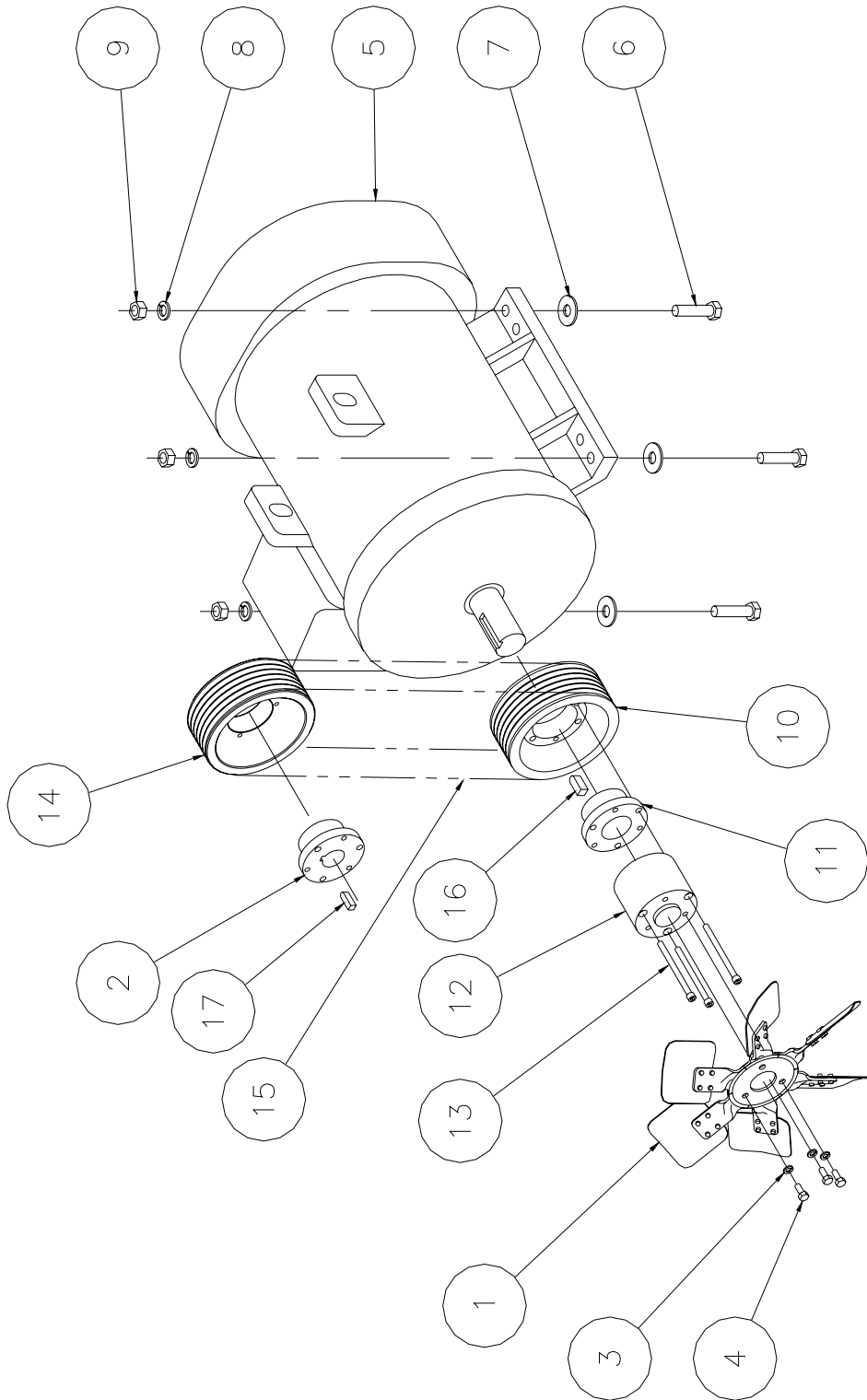

305EFD810-C
(Ref. Drawing)

Order by Part Number and Description. Reference Numbers are for your convenience only.

DRIVE GROUPS – 50 HP ODP & TEFC

Ref. No.	Name of Part	Qty.	100 PSIG		125 PSIG		150 PSIG		175 PSIG	
			B/M: 344EFD4004	Part No.	B/M: 345EFD4004	Part No.	B/M: 346EFD4004	Part No.	B/M: 347EFD4004	Part No.
1	FAN.....	1	300EFD701	300EFD701	300EFD701	300EFD701	300EFD701	300EFD701	300EFD701	300EFD701
2	BUSHING.....	1	22J4	22J4	22J4	22J23	22J23	22J23	22J23	22J23
3	LOCKWASHER.....	3	95B2	95B2	95B2	95B2	95B2	95B2	95B2	95B2
4	SCREW.....	3	75A33	75A33	75A33	75A33	75A33	75A33	75A33	75A33
5	MAIN MOTOR.....	--	See page 39	See page 39	See page 39	See page 39	See page 39	See page 39	See page 39	See page 39
6	SCREW.....	4	655EF100	655EF100	655EF100	655EF100	655EF100	655EF100	655EF100	655EF100
7	WASHER.....	4	95A7	95A7	95A7	95A7	95A7	95A7	95A7	95A7
8	LOCKWASHER.....	4	95B7	95B7	95B7	95B7	95B7	95B7	95B7	95B7
9	NUT.....	4	50B7	50B7	50B7	50B7	50B7	50B7	50B7	50B7
10	SHEAVE.....	1	300EFD099	300EFD099	300EFD099	300EFD099	300EFD099	300EFD099	300EFD099	300EFD099
11	BUSHING.....	1	22F30SK	22F30SK	22F30SK	22F30SK	22F30SK	22F30SK	22F30SK	22F30SK
12	SPACER.....	1	302EFD144	302EFD144	302EFD144	302EFD144	302EFD144	302EFD144	302EFD144	302EFD144
13	SCREW.....	3	75P203	75P203	75P203	75P203	75P203	75P203	75P203	75P203
14	SHEAVE.....	1	309EFD099	309EFD099	310EFD099	304EFD099	304EFD099	304EFD099	306EFD099	306EFD099
15	SET-BELT.....	1	13AJ6006	13AJ6006	13AJ6006	13AJ6306	13AJ6306	13AJ6006	13AJ6006	13AJ6006
16	KEY.....	1	35L88	35L88	35L88	35L88	35L88	35L88	35L88	35L88
17	KEY.....	1	35L74	35L74	35L74	35L74	35L74	35L74	35L74	35L74

DRIVE GROUPS – 40 HP TEFC

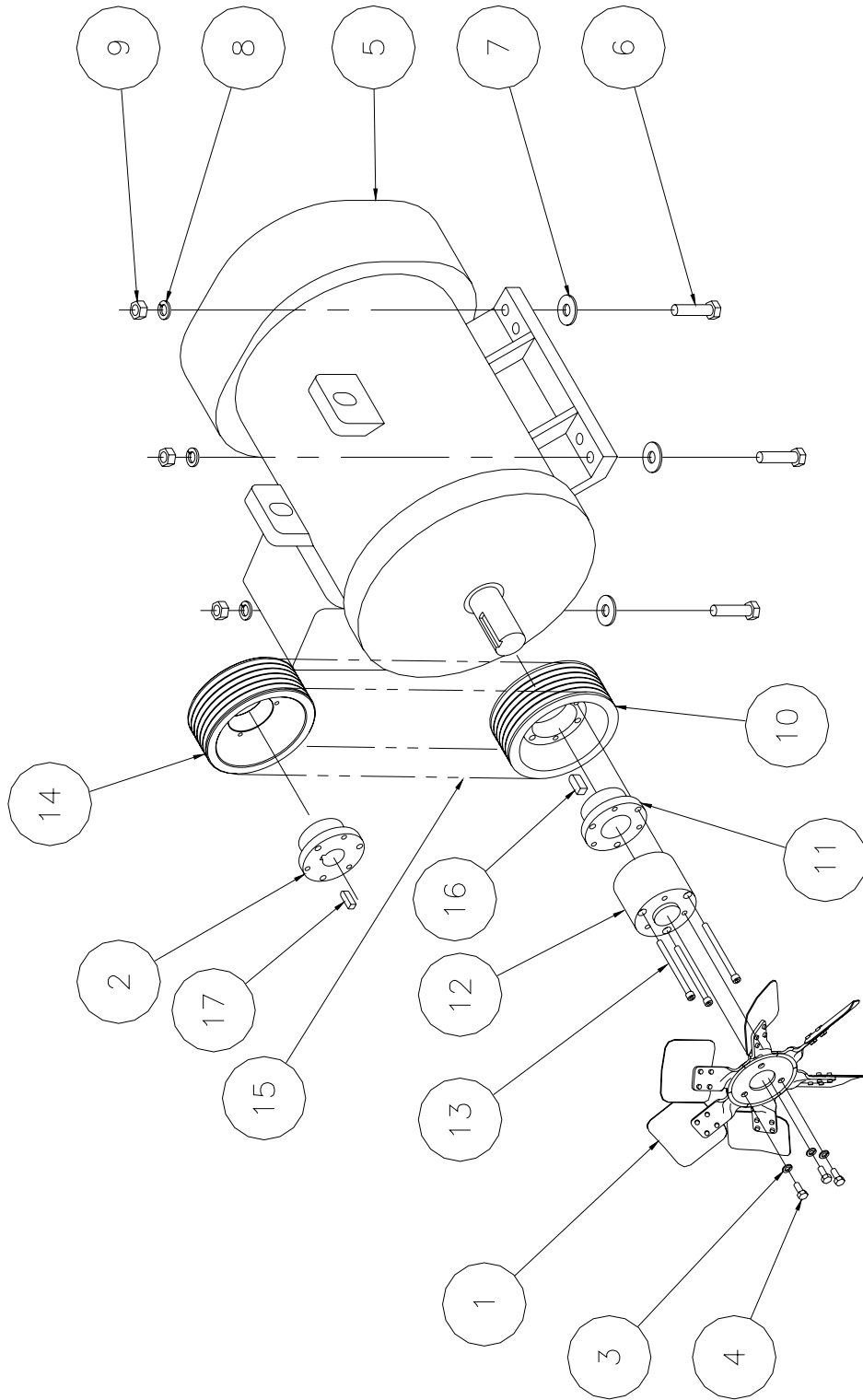

305EFD810-C
(Ref. Drawing)

DRIVE GROUPS – 40 HP TEFC

Ref. No.	Name of Part	Qty.	100 PSIG		125 PSIG		150 PSIG		175 PSIG	
			B/M: 352EFD4004	Part No.	B/M: 353EFD4004	Part No.	B/M: 354EFD4004	Part No.	B/M: 355EFD4004	Part No.
1	FAN.....	1	300EFD701	300EFD701	300EFD701	300EFD701	300EFD701	300EFD701	300EFD701	300EFD701
2	BUSHING.....	1	22J23	22J23	22J23	22J23	22J23	22J23	22J23	22J23
3	LOCKWASHER.....	3	95B2	95B2	95B2	95B2	95B2	95B2	95B2	95B2
4	SCREW.....	3	75A33	75A33	75A33	75A33	75A33	75A33	75A33	75A33
5	MAIN MOTOR.....	--	See page 39	See page 39	See page 39	See page 39	See page 39	See page 39	See page 39	See page 39
6	SCREW.....	4	655EF100	655EF100	655EF100	655EF100	655EF100	655EF100	655EF100	655EF100
7	WASHER.....	4	95A7	95A7	95A7	95A7	95A7	95A7	95A7	95A7
8	LOCKWASHER.....	4	95B7	95B7	95B7	95B7	95B7	95B7	95B7	95B7
9	NUT.....	4	50B7	50B7	50B7	50B7	50B7	50B7	50B7	50B7
10	SHEAVE.....	1	300EFD099	300EFD099	300EFD099	300EFD099	300EFD099	300EFD099	300EFD099	300EFD099
11	BUSHING.....	1	22F30SK	22F30SK	22F30SK	22F30SK	22F30SK	22F30SK	22F30SK	22F30SK
12	SPACER.....	1	302EFD144	302EFD144	302EFD144	302EFD144	302EFD144	302EFD144	302EFD144	302EFD144
13	SCREW.....	3	75P203	75P203	75P203	75P203	75P203	75P203	75P203	75P203
14	SHEAVE.....	1	304EFD099	307EFD099	307EFD099	307EFD099	311EFD099	312EFD099	312EFD099	312EFD099
15	SET-BELT.....	1	13AJ6006	13AJ6006	13AJ6006	13AJ6306	13AJ6306	13AG6306	13AG6306	13AG6306
16	KEY.....	1	35L88	35L88	35L88	35L88	35L88	35L88	35L88	35L88
17	KEY.....	1	35L74	35L74	35L74	35L74	35L74	35L74	35L74	35L74

ENCLOSURE GROUP

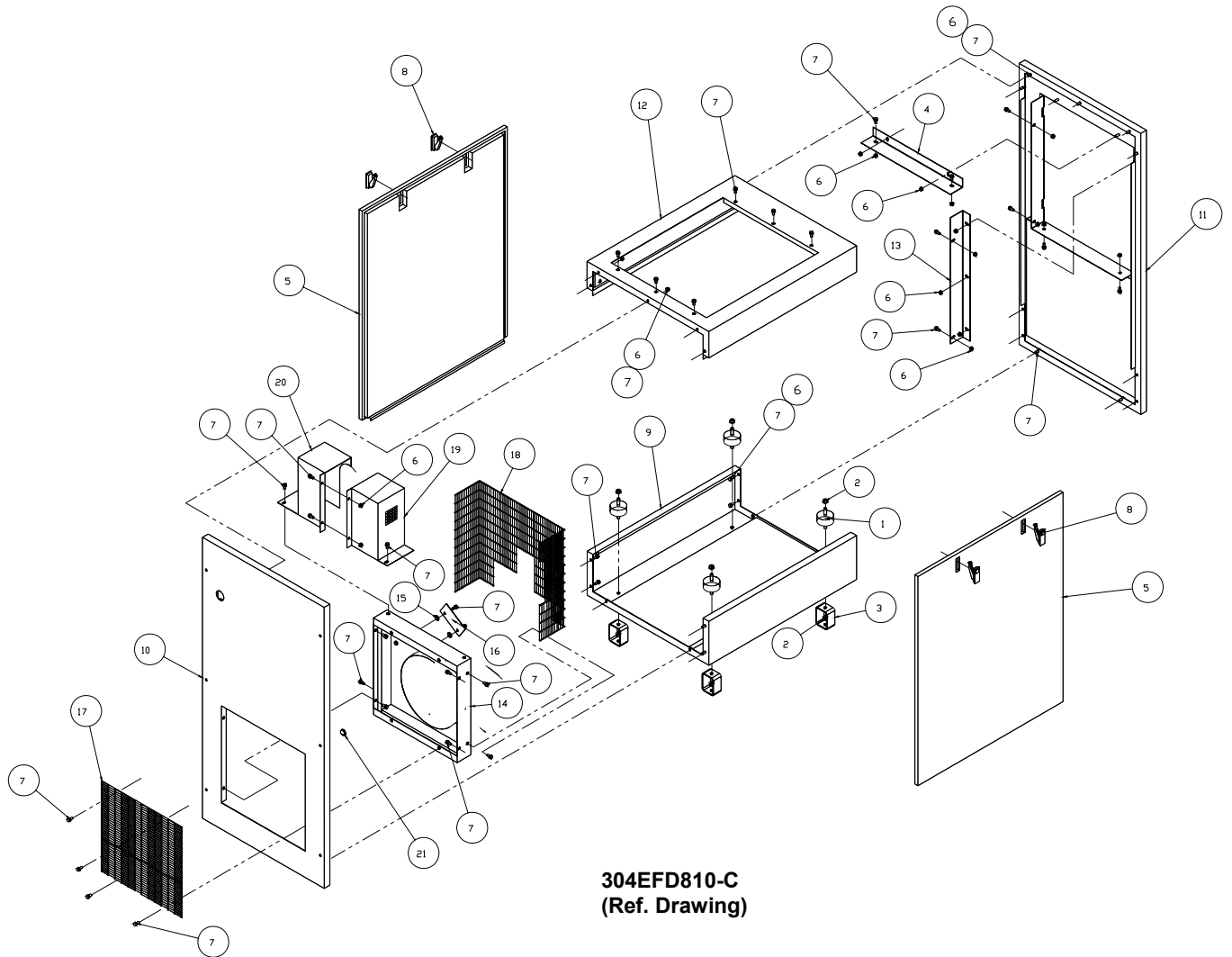

304EFD810-C
(Ref. Drawing)

Order by Part Number and Description. Reference Numbers are for your convenience only.

ENCLOSURE GROUP

B/M: 301EFD4013
B/M: 301EFD4023

Ref. No.	Name of Part	Qty.	Part No.
1	VIBRATION ISOLATOR.....	4	49C105
2	NUT.....	8	50AW35
3	FOOT.....	4	300EVE166
4	BRACKET.....	1	303EFD142
5	PANEL.....	2	CC1018665
6	NUT.....	33	50AW5
7	SCREW.....	54	75LM51
8	LATCH.....	2	31D68
9	FRAME.....	1	300EFD314
10	FRAME.....	1	302EFD314
11	FRAME.....	1	309EFD314
12	FRAME.....	1	303EFD314
13	BRACKET.....	1	304EFD142
14	BAFFLE.....	1	301EFD840
15	WASHER.....	2	95A3
16	BRACKET.....	1	308EVE142
17	GUARD-AUXILIARY.....	1	300EFD240
18	GUARD FAN.....	1	300EFD393
19	COVER.....	1	300EFD225
20	COVER.....	1	301EFD225
21	PLUG-SNAP IN.....	4	24A60
22	KEY (not shown).....	1	VP1014243

QUIET Baffle

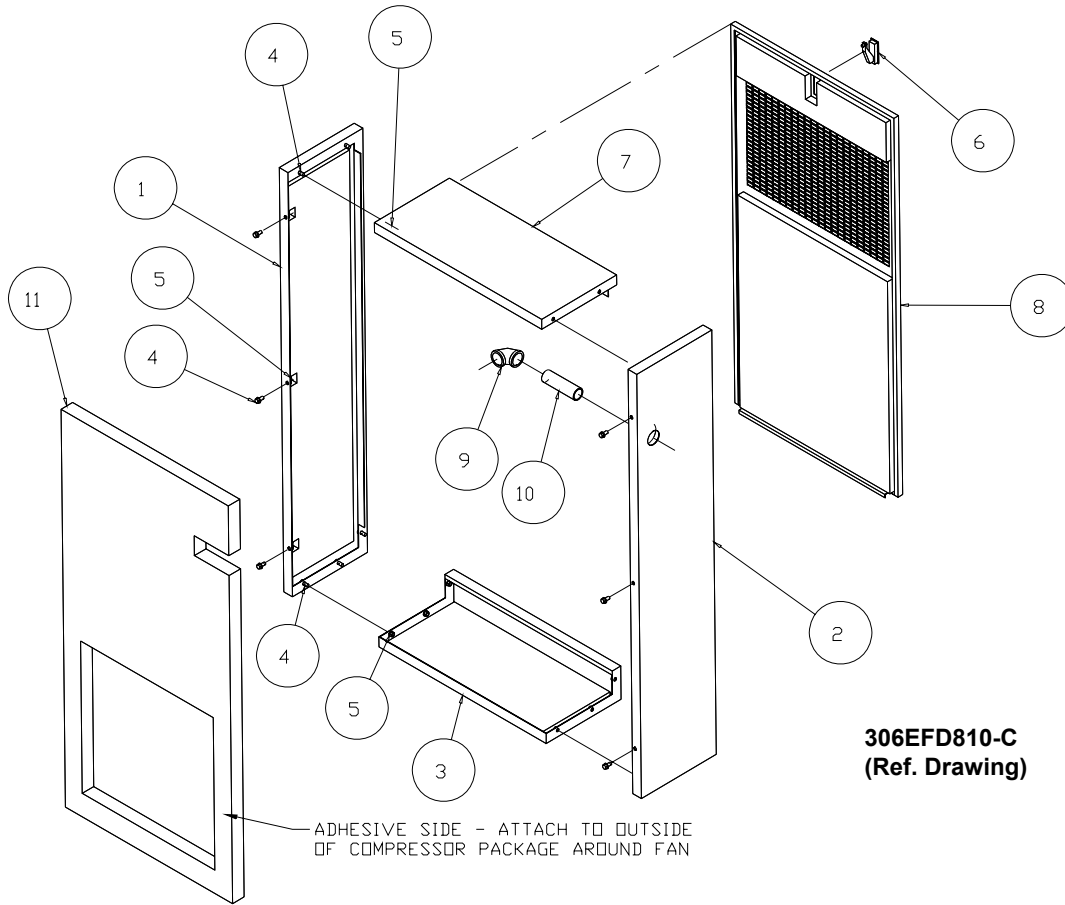

Order by Part Number and Description. Reference Numbers are for your convenience only.

QUIET BAFFLE

B/M: 302EFD4013
B/M: 302EFD4023

Ref. No.	Name of Part	Qty.	Part No.
1	FRAME	1	306EFD314
2	FRAME	1	305EFD314
3	FRAME	1	304EFD314
4	SCREW	16	75LM51
5	NUT	16	50AW5
6	LATCH	1	31D68
7	FRAME	1	307EFD314
8	PANEL	1	CC1018666
9	ELBOW	1	64C7
10	NIPPLE	1	63J21G
11	INSULATION	1	300EFD470

CONTROL PIPING

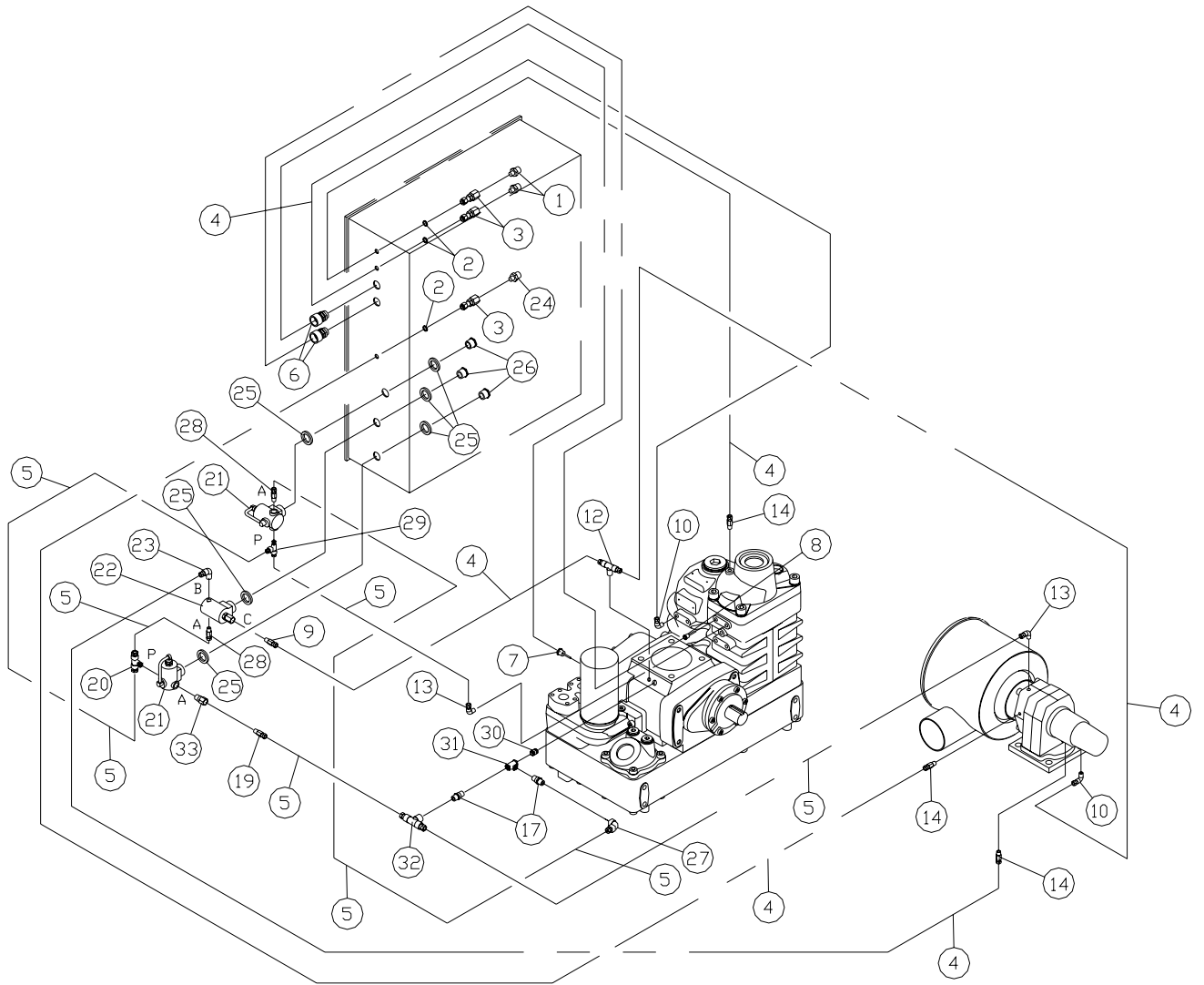

317EFD810-H
(Ref. Drawing)

Order by Part Number and Description. Reference Numbers are for your convenience only.

CONTROL PIPING

B/M: 301EFD4002

Ref. No.	Name of Part	Qty.	Part No.
* 1	TRANSDUCER-PRESSURE	2	88H359
2	O-RING	3	165011
3	CONNECTOR-TUBE	3	86N287
4	TUBE.....	12	85G3
5	TUBE.....	14	85G5
6	FITTING-ELECTRICAL.....	2	24CA2865
* 7	PROBE-ELECTRICAL	1	21D347
* 8	THERMISTOR PROBE.....	1	21D346
9	CONNECTOR.....	1	86E4
10	TUBE WITH FITTINGS.....	2	86H163
12	TUBE WITH FITTINGS.....	1	86H165
13	TUBE WITH FITTINGS.....	2	86H164
14	TUBE WITH FITTINGS.....	3	86H162
** 17	VALVE-CHECK.....	2	90AR261
19	CONNECTOR	1	86E9
20	TEE	1	86N347
* 21	VALVE-SOLENOID.....	2	91B70
* 22	VALVE-SOLENOID	1	91B113
23	ELBOW	1	86E60
* 24	SWITCH-VACUUM	1	88H195
25	O- RING	6	24A383
26	NIPPLE.....	3	24CA4641
27	ELBOW	1	86E82
28	CONNECTOR	2	86E9
29	TEE	1	86E136
30	NIPPLE.....	1	86H152
31	TEE	1	64G3G
32	TEE-TUBE	1	86E147
33	ORIFICE.....	1	201EDE814

* Parts included in Electrical Control Kit Part Number 313EFD6013. Refer to page 42.

** Parts included in Pneumatic Control Kit Part Number 312EFD6013. Refer page 42.

Order by Part Number and Description. Reference Numbers are for your convenience only.

GROUP IDENTIFICATION AND INSTRUCTION

B/M: 303EFD4011

Ref. No.	Name of Part	Qty.	Part No.
1	DECAL, DANGER (DO NOT BREATHE DISCHARGE AIR).....	1	305EFC077
2	DECAL (OIL FILTER ELEMENT - CHAMPION).....	1	301EFC077
3	DECAL, WARNING (ROTATING MACHINERY).....	2	307EFC077
4	DECAL, WARNING (UNIT CAN AUTO RESTART)	1	306EFC077
5	DECAL, DANGER (DO NOT MODIFY W/O PERMISSION)	1	309EFC077
6	DECAL, DANGER (AIR/OIL UNDER PRESSURE).....	1	308EFC077
8	DECAL ROTATION ARROW.....	1	304EFC077
9	DECAL (CHAMPION) ROTORCHAMP	1	310EBA077
10	DECAL OPERATION & MAINTENANCE	1	312EFC077
12	DECAL, WARNING OUTSIDE CONTROL BOX	1	310EFC077
13	DECAL, DANGER INSIDE CONTROL BOX	1	311EFC077
17	DECAL (CHAMPION) LARGE	2	308EBA077

Order by Part Number and Description. Reference Numbers are for your convenience only.

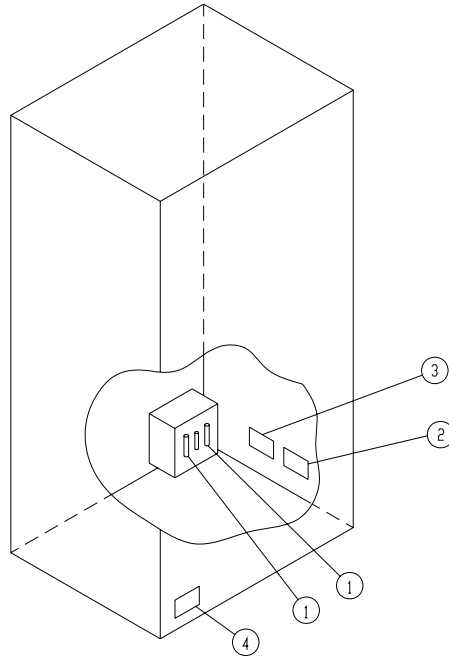

315EFD810-A
(Ref. Drawing)

DECAL & FUSE GROUP

Ref. No.	Name of Part	Qty.	B/M: 316EFD4007	B/M: 317EFD4007	B/M: 318EFD4007	B/M: 319EFD4007
			200V	230V	460V	575V
1	FUSE	2	24CA2786	24CA2785	24CA2782	24CA2781
2	DECAL	1	265AUX077	264AUX077	261AUX077	260AXU077
3	DECAL	1	297AUX077	297AUX077	297AUX077	297AUX077
4	MARKER-VOLTAGE ...	1	69F50	69F51	69F52	69F60

CONTROLLER ASSEMBLY – FULL VOLTAGE STARTER – 40 & 50 HP

**309EFD810-C
(Ref. Drawing)**

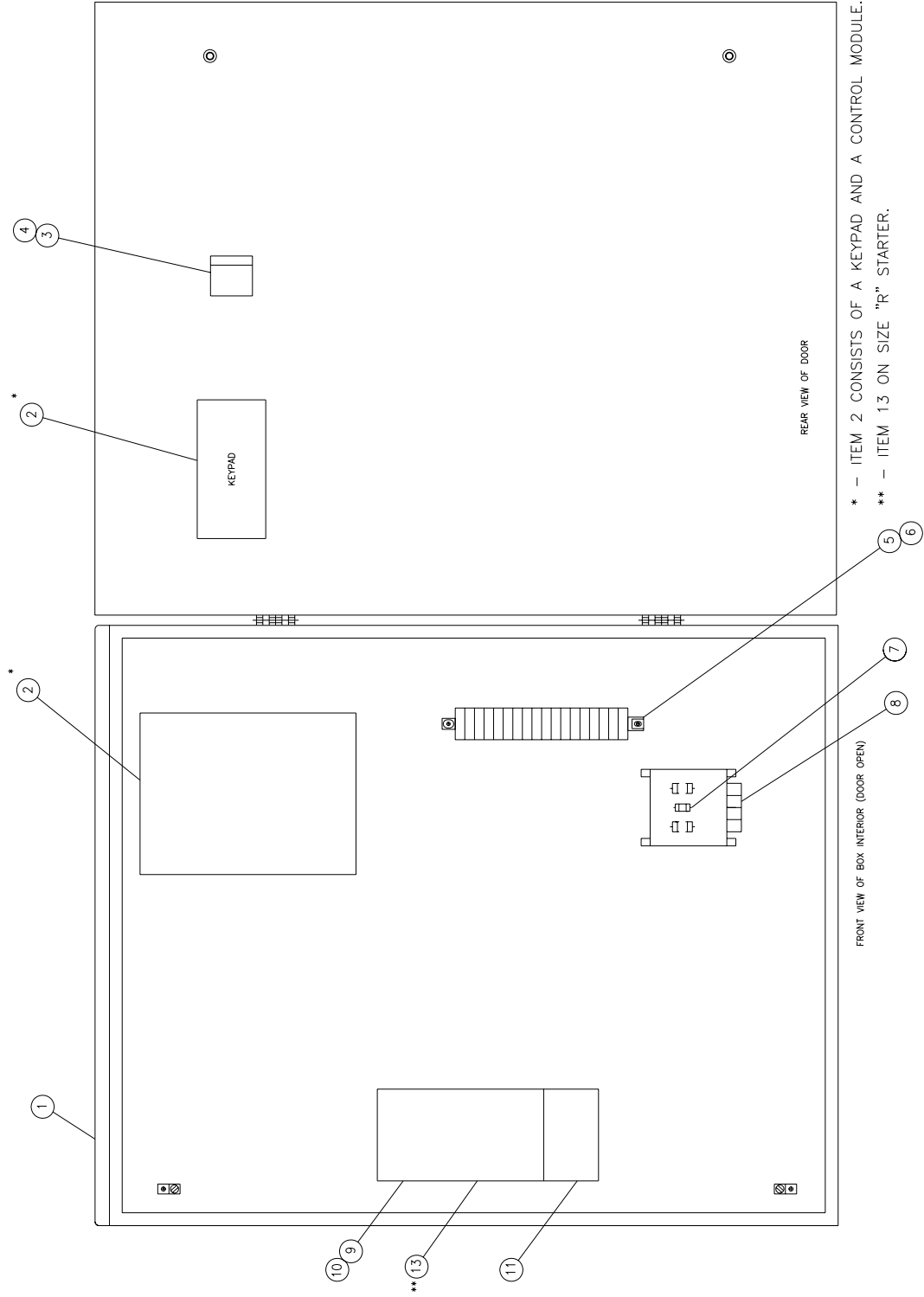

Order by Part Number and Description. Reference Numbers are for your convenience only.

CONTROLLER ASSEMBLY – FULL VOLTAGE STARTER – 40 & 50 HP

	QTY.	40 HP 200V	50 HP 200V	40-50 HP 230V	40-50 HP 460V	40-50 HP 575V
NEMA 12 CONTROL BOX (RS2000)		328EFD466	330EFD466	334EFD466	332EFD466	336EFD466
NEMA 4 CONTROL BOX (RS2000)		329EFD466	331EFD466	335EFD466	333EFD466	337EFD466
NEMA 12 CONTROL BOX (AIRPILOT+)		304EFD466	326EFD466	308EFD466	306EFD466	310EFD466
NEMA 4 CONTROL BOX (AIRPILOT+)		305EFD466	327EFD466	309EFD466	307EFD466	311EFD466
1 CONTROL/STARTER BOX (NEMA 12).....	1	302EFD179	302EFD179	302EFD179	302EFD179	302EFD179
CONTROL/STARTER BOX (NEMA 4).....	1	303EFD179	303EFD179	303EFD179	303EFD179	303EFD179
2 CONTROLLER ASSEMBLY (RS2000).....	(See Pages 37 & 38)					
CONTROLLER ASSEMBLY (AIRPILOT+).....	(See Pages 37 & 38)					
3 OPERATOR.....	1	24CA2907	24CA2907	24CA2907	24CA2907	24CA2907
4 CONTACT BLOCK.....	1	24CA2908	24CA2908	24CA2908	24CA2908	24CA2908
5 BLOCK-TERMINAL CONTACT.....	6	24CA2551	24CA2551	24CA2551	24CA2551	24CA2551
6 BLOCK-TERMINAL END.....	1	24CA2552	24CA2552	24CA2552	24CA2552	24CA2552
7 FUSE.....	1	24CA3725	24CA3725	24CA3725	24CA3725	24CA3725
8 TRANSFORMER.....	1	24CA5182	24CA5182	24CA5181	24CA5181	24CA5183
9 CONTACTOR.....	1	24CA3259	24CA4158	24CA3259	24CA3258	24CA3258
10 COIL.....	1	2116555	2116920	2116555	2116124	2116124
11 RELAY.....	1	24CA2905	24CA2905	24CA2905	24CA2905	24CA2905
12 CONTACT.....	1	-----	24CA3716	-----	-----	-----
13 CONTACT KIT.....	1	-----	2116915	-----	-----	-----

CONTROLLER ASSEMBLY – WYE DELTA STARTER – 40 & 50 HP

**310EFD810-B
(Ref. Drawing)**

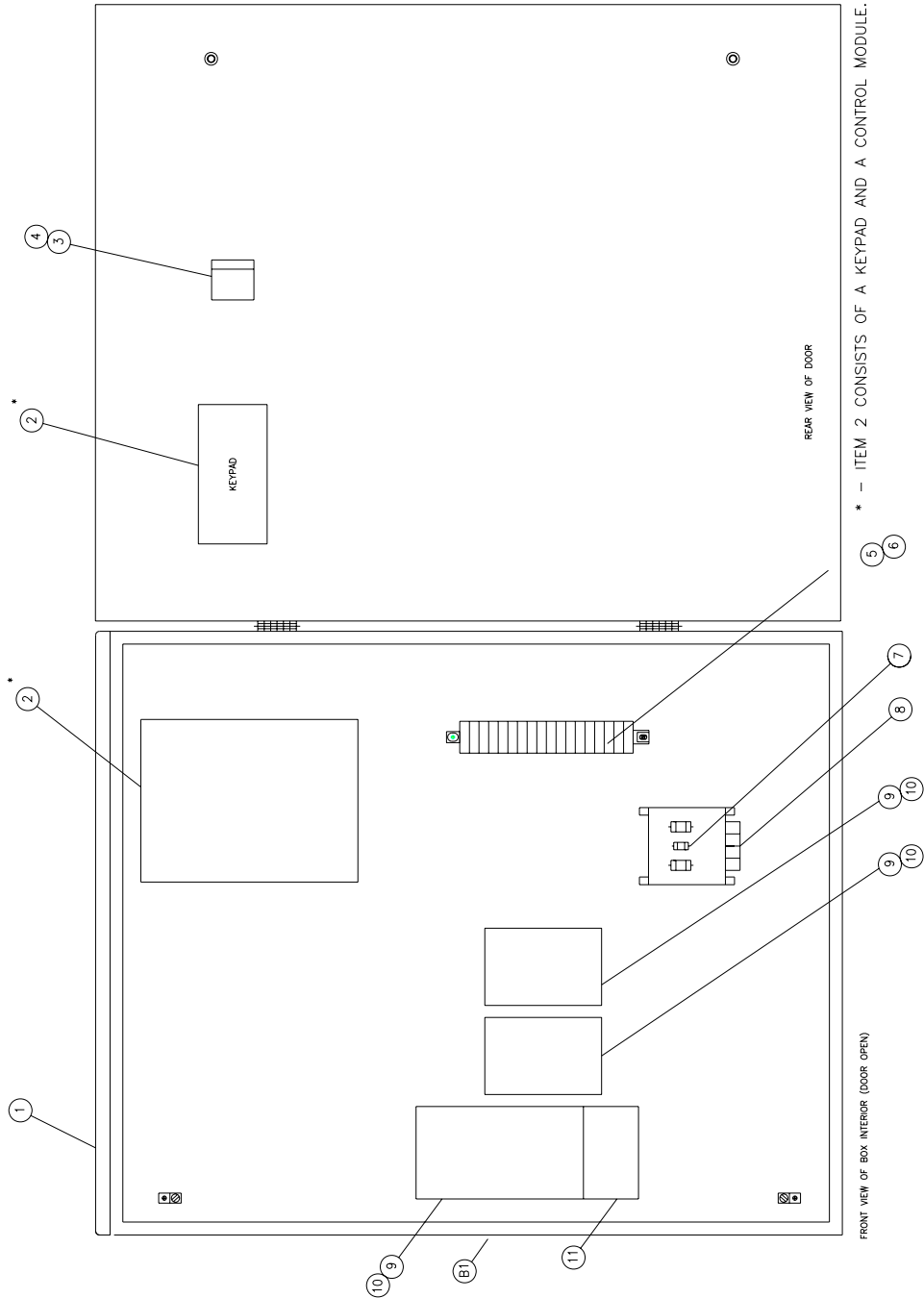

Order by Part Number and Description. Reference Numbers are for your convenience only.

CONTROLLER ASSEMBLY – WYE DELTA STARTER

	QTY.	40 HP 200V	40-50 HP 230V	40-50 HP 460V	40-50 HP 575V
NEMA 12 CONTROL BOX (RS2000)		338EFD466	342EFD466	340EFD466	344EFD466
NEMA 4 CONTROL BOX (RS2000)		339EFD466	343EFD466	341EFD466	345EFD466
NEMA 12 CONTROL BOX (AIRPILOT+)		312EFD466	316EFD466	314EFD466	318EFD466
NEMA 4 CONTROL BOX (AIRPILOT+)		313EFD466	317EFD466	315EFD466	319EFD466
1 CONTROL/STARTER BOX (NEMA 12).....	1	302EFD179	302EFD179	302EFD179	302EFD179
CONTROL/STARTER BOX (NEMA 4).....	1	303EFD179	303EFD179	303EFD179	303EFD179
2 CONTROLLER ASSEMBLY (RS2000).....	(See Pages 37 & 38)				
CONTROLLER ASSEMBLY (AIRPILOT+).....	(See Pages 37 & 38)				
3 OPERATOR.....	1	24CA2907	24CA2907	24CA2907	24CA2907
4 CONTACT BLOCK.....	1	24CA2908	24CA2908	24CA2908	24CA2908
5 BLOCK-TERMINAL CONTACT.....	6	24CA2551	24CA2551	24CA2551	24CA2551
6 BLOCK-TERMINAL END.....	1	24CA2552	24CA2552	24CA2552	24CA2552
7 FUSE.....	1	24CA3725	24CA3725	24CA3725	24CA3725
8 TRANSFORMER.....	1	24CA5182	24CA5181	24CA5181	24CA5183
9 CONTACTOR.....	3	24CA3259	24CA3259	24CA3258	24CA3258
10 COIL.....	3	2116555	2116555	2116124	2116124
11 RELAY.....	1	24CA2905	24CA2905	24CA4087	24CA4087

CONTROLLER ASSEMBLY – LESS MAIN MOTOR STARTER

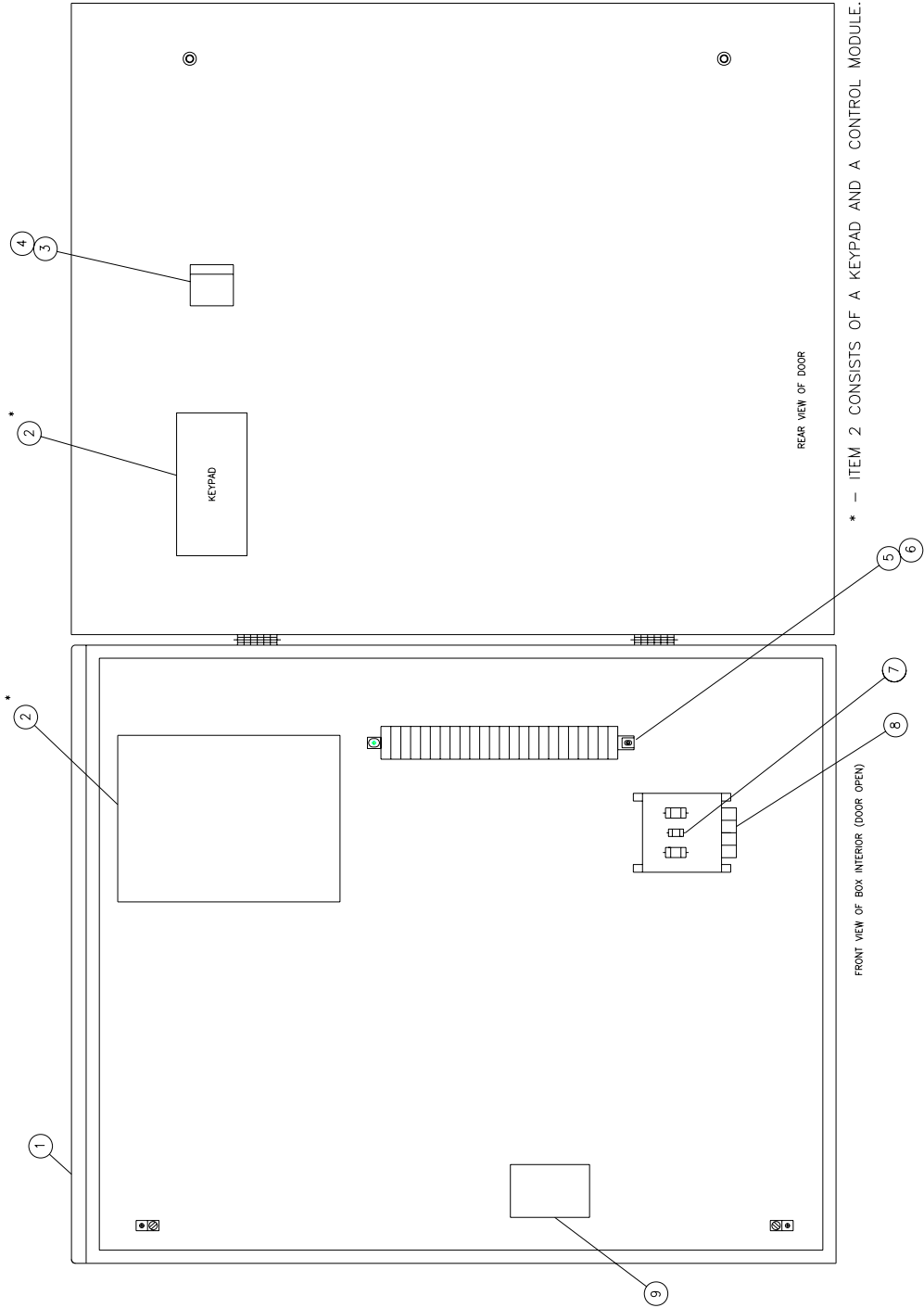

**311EFD810-B
(Ref. Drawing)**

Order by Part Number and Description. Reference Numbers are for your convenience only.

CONTROLLER ASSEMBLY – LESS MAIN MOTOR STARTER

	QTY.	200V	230V	460V	575V
NEMA 12 CONTROL BOX (RS2000)		346EFD466	348EFD466	348EFD466	350EFD466
NEMA 4 CONTROL BOX (RS2000)		347EFD466	349EFD466	349EFD466	351EFD466
NEMA 12 CONTROL BOX (AIRPILOT+)		320EFD466	322EFD466	322EFD466	324EFD466
NEMA 4 CONTROL BOX (AIRPILOT+)		321EFD466	323EFD466	323EFD466	325EFD466
1 CONTROL/STARTER BOX (NEMA 12).....	1	302EFD179	302EFD179	302EFD179	302EFD179
CONTROL/STARTER BOX (NEMA 4).....	1	303EFD179	303EFD179	303EFD179	303EFD179
2 CONTROLLER ASSEMBLY (RS2000).....	(See Pages 37 & 38)				
CONTROLLER ASSEMBLY (AIRPILOT+).....	(See Pages 37 & 38)				
3 OPERATOR.....	1	24CA2907	24CA2907	24CA2907	24CA2907
4 CONTACT BLOCK.....	1	24CA2908	24CA2908	24CA2908	24CA2908
5 BLOCK-TERMINAL CONTACT.....	8	24CA2551	24CA2551	24CA2551	24CA2551
6 BLOCK-TERMINAL END.....	1	24CA2552	24CA2552	24CA2552	24CA2552
7 FUSE.....	1	24CA3725	24CA3725	24CA3725	24CA3725
8 TRANSFORMER.....	1	24CA5182	24CA5181	24CA5181	24CA5183
9 RELAY.....	1	24CA4711	24CA4711	24CA4711	24CA4711

Order by Part Number and Description. Reference Numbers are for your convenience only.

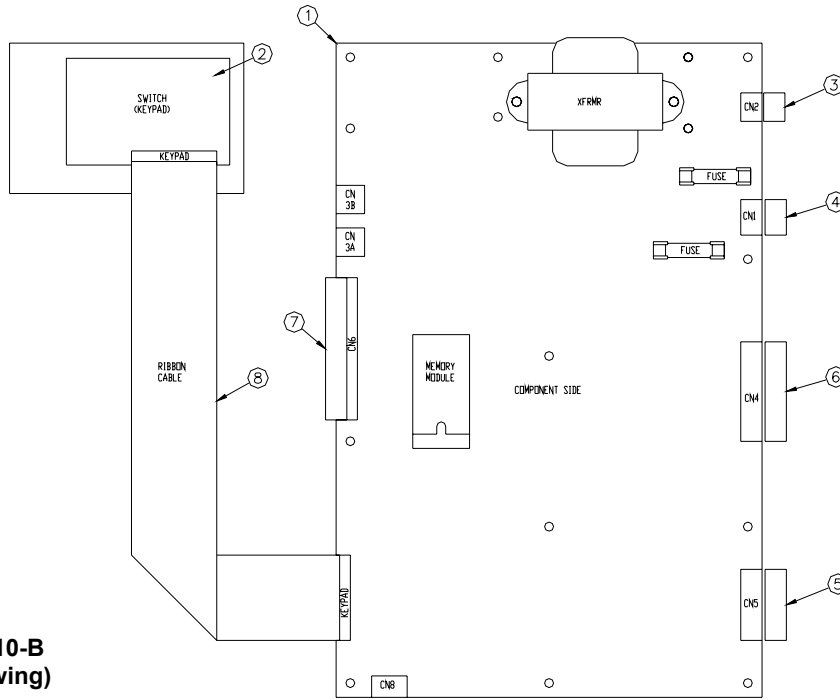

300EBC810-B
(Ref. Drawing)

CONTROLLER ASSEMBLY

Ref. No.	Name of Part	Qty.	RS2000	AIRPILOT+
			B/M: 300EBC2006	B/M: 300EFD2006
			Part No.	Part No.
1	CONTROLLER ASSEMBLY – BOARD	1	300EBC560	300EFD560
2	SWITCH (KEYPAD).....	1	300EVE375	300EVE375
3	PLUG-CONNECTOR.....	1	24CA4240	24CA4240
4	PLUG-CONNECTOR.....	1	24CA3401	24CA3401
5	PLUG-TERMINAL.....	1	24CA4823	24CA4823
6	PLUG-TERMINAL.....	1	24CA4999	24CA4999
7	PLUG-CONNECTOR.....	1	24CA3306	24CA3306
8	CABLE	1	24CA5178	24CA5178

Order by Part Number and Description. Reference Numbers are for your convenience only.

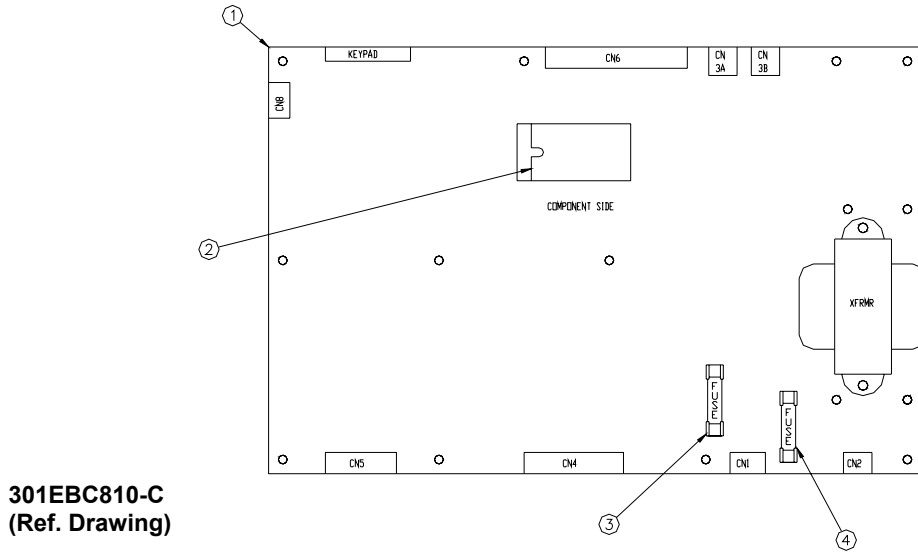

CONTROLLER ASSEMBLY - BOARD

Ref. No.	Name of Part	Qty.	RS2000 B/M: 300EBC560 Part No.	AIRPILOT+ B/M: 300EFD560 Part No.
1	CONTROLLER	1	*	*
2	MEMORY MODULE	1	300EBC566	300EFD566
3	FUSE	1	24CA2932	24CA2932
4	FUSE	1	24CA2932	24CA2932

* Part Number not available for repair.

**MAIN MOTOR
(FULL VOLTAGE and WYE DELTA)**

Name of Part	Full Voltage 40 HP (3600 RPM) Part No.	Full Voltage 50 HP (3600 RPM) Part No.	WYE Delta 40 HP (3600 RPM) Part No.	WYE Delta 50 HP (3600 RPM) Part No.
OPEN DRIP PROOF STANDARD EFFICIENCY (60 HZ – ODP)				
MOTOR, 200V	24CA5214	24CA5215	24CA5351	24CA5354
MOTOR, 230V	24CA5352	24CA5355	24CA5352	24CA5355
MOTOR, 460V	24CA5352	24CA5355	24CA5352	24CA5355
MOTOR, 575V	24CA5218	24CA5219	24CA5353	24CA5356
TOTALLY ENCLOSED STANDARD EFFICIENCY (60 HZ – TEFC)				
MOTOR, 200V	24CA5226	24CA5228	24CA5363	24CA5366
MOTOR, 230V	24CA3358	24CA3359	24CA5364	24CA5367
MOTOR, 460V	24CA3358	24CA3359	24CA5364	24CA5367
MOTOR, 575V	24CA5173	24CA5229	24CA5365	24CA5368
OPEN DRIP PROOF HIGH EFFICIENCY (60 HZ – ODP, HI-EFF)				
MOTOR, 200V	24CA5220	24CA5223	24CA5357	24CA5360
MOTOR, 230V	24CA5221	24CA5224	24CA5358	24CA5361
MOTOR, 460V	24CA5221	24CA5224	24CA5358	24CA5361
MOTOR, 575V	24CA5222	24CA5225	24CA5359	24CA5362
TOTALLY ENCLOSED HIGH EFFICIENCY (60 HZ – TEFC, HI-EFF))				
MOTOR, 200V	24CA5230	24CA5232	24CA5369	24CA5372
MOTOR, 230V	24CA5159	24CA5233	24CA5370	24CA5373
MOTOR, 460V	24CA5159	24CA5233	24CA5370	24CA5373
MOTOR, 575V	24CA5231	24CA5234	24CA5371	24CA5374

OVERLOAD RELAY HEATER CONVERSION LISTING

Refer to Motor nameplate "Amperage" and Decal in
Control Panel for Selection of Overload Relay Heater

CUTLER-HAMMER PART NUMBER	GARDNER DENVER PART NUMBER5
H2002B	24CA4101
H2003B	24CA4102
H2004B	24CA4103
H2005B	24CA4104
H2006B	24CA4105
H2007B	24CA4106
H2008B	24CA4107
H2009B	24CA4108
H2010B	24CA4109
H2011B	24CA4110
H2012B	24CA4111
H2013B	24CA4112
H2014B	24CA4113
H2015B	24CA4114
H2016B	24CA4115
H2017B	24CA4116
H2018	24CA2924
H2019	24CA2925
H2020	24CA2926
H2021	24CA2927
H2022	24CA2893
H2023	24CA2894
H2024	24CA2928

REPAIR KITS

Your Champion rotary screw compressor is designed and manufactured for many years of reliable operation. All components are engineered to exacting specifications, which will function together as a system to provide maximum efficiency. To insure the continuing integrity of compressor operation, use only original quality genuine Champion replacement parts and accessories.

Name of Part	Qty.	Part No.
ROUTINE MAINTENANCE KIT		310EFD6013
ELEMENT, AIR FILTER.....	4	2117910
ELEMENT, OIL FILTER.....	3	2117916
PERIODIC MAINTENANCE KIT (Inlet Valve).....		302EFD6013
INLET VALVE REPAIR KIT (Items 1-6, 10, 12, 15, 16, 18, 19)	1	EFC89555469
O-RING	1	EFC30861088
PERIODIC MAINTENANCE KIT (Minimum Pressure/Check Valve).....		303EFD6013
MINIMUM PRESSURE/CHECK VALVE REPAIR KIT (Items 2, 4-14).....	1	EFC89573379
O-RING	1	EFC89562879
OIL SEPARATOR KIT		311EFD6013
OIL SEPARATOR	2	2117908
O-RING	1	EFC89562879
LUBRICANT.....	1	2116755
THERMAL MIXING VALVE ELEMENT REPAIR KIT		304EFD6013
THERMOSTAT ELEMENT	1	EFC89560169
SPRING	1	EFC89565369
GASKET.....	1	EFC28335250
O-RING	1	EFC89560299
O-RING	1	EFC89565109
O-RING	1	EFC86906369
O-RING	1	EFC89534789
O-RING	2	EFC89507729
DRIVE SHAFT SEAL KIT.....		300EFD6029
SHAFT SEAL KIT	1	EFC30834028
GASKET.....	1	EFC30805908
GASKET ELIMINATOR	1	25BC632
DRIVE SHAFT SEAL TOOL KIT.....		314EFD6013
INTAKE VALVE TOOL.....	1	EFC37601938
SHAFT SEAL TOOL (Drift)	1	EFC03416008
SHAFT SEAL TOOL (Pressing Tool).....	1	EFC03424838
SHAFT SEAL TOOL	1	EFC03424708
WEAR SLEEVE PULLER	1	EFC89587189

REPAIR KITS (CONTINUED)

Name of Part	Qty.	Part No.
BARE AIREND KIT		306EFD6013
AIREND.....	1	CC1013253
O-RING	1	EFC89558369
PERIODIC OVERHAUL KIT, AIREND.....		307EFD6013
SHAFT SEAL KIT	1	EFC30834028
OVERHAUL KIT (Includes Bearings and Gaskets).....	1	EFC50308330
O-RING	1	EFC89558369
PNEUMATIC CONTROLS		312EFD6013
CHECK VALVE	2	90AR261
CHECK VALVE	1	EFC87340549
STRAINER.....	1	EFC85588619
ELECTRICAL CONTROL GROUP		313EFD6013
TRANSDUCER	2	88H359
THERMISTOR PROBE.....	1	21D347
THERMISTOR PROBE.....	1	21D346
SOLENOID VALVE.....	2	91B70
SOLENOID VALVE.....	1	91B113
VACUUM SWITCH	1	88H195
LUBRICANT (ROTORLUB 2000)		
5-GALLON PAIL	1	28H170
55-GALLON DRUM	1	28H171
LUBRICANT (ROTORLUB 4000) - STANDARD		
5-GALLON PAIL	1	28H166
55-GALLON DRUM	1	28H167
LUBRICANT (ROTORLUB 4000FG)		
5-GALLON PAIL	1	28H168
55-GALLON DRUM	1	28H169
LUBRICANT (ROTORLUB 8000)		
5-GALLON PAIL	1	28H164
55-GALLON DRUM	1	28H165
TOUCH-UP PAINT, White		
5-GALLON PAIL	1	28H76
1-GALLON CAN.....	1	28H84
1-QUART CAN.....	1	28H83

CHAMPION[®]

A Gardner Denver Product

©2005 Gardner Denver, Inc.
Litho in U.S.A.

www.championpneumatic.com

Champion
1301 North Euclid Avenue
Princeton, Illinois 63156 USA
Phone: (815) 875-3321
Fax: 815-872-0421

E-mail: champion@championpneumatic.com



Plants in Princeton IL, and Manteca, CA

Due to Champion's continuing product development program, specification and materials are subject to change without notice.