



13-18-611
Version: 00
Dec 3, 2018

**VARIABLE SPEED
SINGLE STAGE
STATIONARY BASE-MOUNTED
COMPRESSOR**

AirSmart™ CONTROLLER

VS45-70C

45-50-70kW

60HZ

**OPERATING AND
SERVICE MANUAL**

**MAINTAIN COMPRESSOR RELIABILITY AND PERFORMANCE WITH
GENUINE GARDNER DENVER® COMPRESSOR PARTS AND SUPPORT SERVICES**

Gardner Denver® Compressor genuine parts, manufactured to design tolerances, are developed for optimum dependability – specifically for Gardner Denver compressor systems. Design and material innovations are the result of years of experience with hundreds of different compressor applications. Reliability in materials and quality assurance is incorporated in our genuine replacement parts.

Your authorized Gardner Denver Compressor distributor offers all the backup you'll need. An AirSmart™ network of authorized distributors provides the finest product support in the air compressor industry.

Your authorized distributor can support your Gardner Denver air compressor with these services:

1. Trained parts specialists to assist you in selecting the correct replacement parts.
2. Factory warranted new and remanufactured rotary screw airends. Most popular model remanufactured airends are maintained in stock at the factory, for purchase on an exchange basis with liberal core credit available for the replacement unit.
3. A full line of factory tested AEON™ compressor lubricants specifically formulated for use in Gardner Denver compressors.
4. Repair and maintenance kits designed with the necessary parts to simplify servicing your compressor.

Authorized distributor service technicians are factory trained and skilled in compressor maintenance and repair. They are ready to respond and assist you by providing fast, expert maintenance and repair services.

To Contact Gardner Denver or locate your local distributor:

Visit: www.contactgd.com/compressors

Or

Call: (800)682-9868

INSTRUCTIONS FOR ORDERING REPAIR PARTS/REMANUFACTURED AIRENDS

Whenever an airend requires replacement or repair, Gardner Denver offers an industry unique, factory remanufactured airend exchange program. From its modern Remanufacturing center in Indianapolis, IN., Gardner Denver is committed to supplying you with the highest quality, factory remanufactured airends that are guaranteed to save you time, aggravation and money

When ordering parts, specify Compressor MODEL, Method of Cooling, POWER and SERIAL NUMBER (see nameplate on unit). The Airend Serial Numbers are also stamped on top of the discharge bearing carrier castings.

All orders for Parts should be placed with the nearest authorized distributor.

Where NOT specified, quantity of parts required per compressor or unit is one (1); where more than one is required per unit, quantity is indicated in parenthesis. SPECIFY EXACTLY THE NUMBER OF PARTS REQUIRED.

DO NOT ORDER BY SETS OR GROUPS.

To determine the Right-Hand and Left-Hand side of a compressor, stand at the motor end and look toward the compressor. Right-Hand and Left- Hand are indicated in parenthesis following the part name, i.e. (RH) and (LH), when appropriate.

WARNING – PROHIBITION – MANDATORY LABEL INFORMATION

Gardner Denver Rotary Screw compressors are the result of advanced engineering and skilled manufacturing. To be assured of receiving maximum service from this machine, the owner must exercise care in its operation and maintenance. This book is written to give the operator and maintenance department essential information for day-to-day operation, maintenance and adjustment. Careful adherence to these instructions will result in economical operation and minimum downtime.

Boxed text formats are used, within this manual, to alert users of the following conditions:

Safety Labels are used, within this manual and affixed to the appropriate areas of the compressor package, to alert users of the following conditions:



Indicates a hazard with a high level of risk, which if not avoided, WILL result in death or serious injury.



Equipment starts automatically



Health Hazard – Explosive Release of Pressure



Cutting of Finger or Hand Hazard – Rotating impeller blade



High Voltage – Hazard of Shock, Burn, or Death Present until Electrical Power is Removed



Cutting of Finger or Hand Hazard – Rotating fan blade



Entanglement of Fingers or Hand/Rotating Shaft



Indicates a hazard with a medium level of risk which, if not avoided, **COULD** result in death or serious injury.



Asphyxiation Hazard – Poisonous Fumes or Toxic Gases in Compressed Air



Indicates a hazard with a low level of risk which, if not avoided, **MAY** result in a minor or moderate injury.



Burn Hazard – Hot surface

PROHIBITION/MANDATORY ACTION REQUIREMENTS



Do not Operate Compressor with Guard Removed



Lockout Electrical Equipment in De-Energized State



Do Not Lift Equipment with Hook – No Lift Point



Loud Noise Hazard – Wear Ear Protection



Handle Package at Forklift Points Only



Read the Operator's Manual Before Proceeding with Task

SAFETY PRECAUTIONS

Safety is everybody's business and is based on your use of good common sense. All situations or circumstances cannot always be predicted and covered by established rules. Therefore, use your past experience, watch out for safety hazards and be cautious. Some general safety precautions are given below:



Failure to observe these notices could result in injury to or death of personnel.

- **Keep fingers and clothing away** from rotating fan, drive coupling, etc.
- **Disconnect the compressor unit** from its power source, lockout and tagout before working on the unit – this machine is automatically controlled and may start at any time.
- **Do not loosen or remove** the oil filler plug, drain plugs, covers, the thermostatic mixing valve or break any connections, etc., in the compressor air or oil system until the unit is shut down and the air pressure has been relieved.
- **Electrical shock** can and may be fatal.
- **Perform all wiring** in accordance with the National Electrical Code (NFPA-70) and any applicable local electrical codes. Wiring and electrical service must be performed only by qualified electricians.
- **Open main disconnect switch**, lockout and tagout before working on the control, wait 10 minutes and check for voltage.



Failure to observe these notices could result in damage to equipment.

- **Stop the unit** if any repairs or adjustments on or around the compressor are required.
- **Do not use the air discharge** from this unit for breathing – not suitable for human consumption.
- **An Excess Flow Valve** should be on all compressed air supply hoses exceeding 1/2 inch inside diameter (OSHA Regulation, Section 1926.302).
- **Do not exceed** the rated maximum pressure values shown on the nameplate.
- **Do not operate unit** if safety devices are not operating properly. Check periodically. Never bypass safety devices.

TABLE OF CONTENTS

Maintain Compressor Reliability And Performance With Genuine Gardner Denver Compressor Parts And Support Services	1
Instructions For Ordering Repair Parts/Remanufactured Airends	1
Warning – Prohibition – Mandatory Label Information.....	1
Safety Precautions	3
Index.....	5
List Of Illustrations.....	6
Section 1, General Information	7
Section 2, Installation	12
Section 3, Starting & Operating Procedures	18
Section 4, Controls & Instrumentation	25
Section 5, Compressor Lubrication - Separation, Filtration And Controls	46
Section 6 - Heat Exchangers (Oil, Air)	54
Section 7, Air Filter.....	61
Section 8, Shaft Coupling.....	63
Section 9, Minimum Pressure/Check Valve.....	68
Section 10, Inlet Control Valve.....	70
Section 11, Pressure Relief Valve	71
Section 12, Ventilation Fans, Filters (Electrical Enclosure)	73
Section 13, Motor Lubrication	74
Section 14, Maintenance Schedule	75
Section 15, Troubleshooting	77

This book covers the following models:

KW	PSIG	Air Cooled and Water Cooled	Parts List	Controller Manual	Dryer Manual	Comm. Module
45, 50, 70	100 THRU 175	VS45-70C	13-18-508	13-17-600	13-18-605	13-17-604

NOTICE

Gardner Denver factory remanufactured replacement compressor airend units are available from your authorized distributor, on an exchange basis, for all rotary screw compressor units.

INDEX

Air Filter, Section 7	61	Addition Of Oil Between Changes.....	47
Air Flow In The Compressor System	7	Compressor.....	46
Air-Cooled Units, Location	13	Draining And Cleaning	48
Auxiliary Air Receiver	15	Moisture.....	47
Cold Weather Installation	14	Oil Change Interval.....	48
Compression Principle	7	Oil Filter	49
Compressor Lubrication – Separation, Filtration And Controls, Section 5	46	Oil Mixing Valve.....	50
Control Piping.....	15	Oil Separation Reservoir/Coalescing Element	52
Controls & Instrumentation, Section 4	25	Oil Sight Glass.....	47
Discharge Service Line	15	Oil Specifications.....	46
Electrical Wiring	16	Recommended Lubricant	46
Enclosure	14	Refilling Oil	49
Foundation	14	Piping	
General Information, Section 1	7	Blow Down Valve	15
Grounding.....	17	Control.....	15
Heat Exchangers (Oil, Air), Section 6	54	Water	15
Inlet Control Valve, Section 10.....	70	Pressure Relief Valve, Section 11	71
Inlet Line.....	15	Prestart-Up Instructions	18
Installation, Section 2	12	Quick Start Guide.....	21
Lifting Unit	12	Safety Precautions.....	3
Location		Service Check List	75
Air-Cooled Units	13	Every 1000 Hours.....	75
Water-Cooled Units	13	Every 3000 Hours.....	75
Location.....	13	Every 8000 Hours.....	75
Lubrication		Weekly.....	75
Cooling.....	7	Yearly	76
Sealing.....	7	Shaft Coupling, Section 8	63
Maintenance Schedule, Section 14	75	Starting & Operating Procedures, Section 3....	18
Minimum Pressure/Check Valve, Section 9.....	68	Starting The Unit.....	23
Moisture Separator/Trap (Optional)	15	Stopping The Unit	23
Oil Filter	49	Troubleshooting, Section 15	77
Oil Reservoir Drain.....	14	Ventilation Filters (Electrical Enclosure), Section 12	73
Oil System		Warning – Prohibition – Mandatory Label Information	1
		Water-Cooled Units, Location.....	13

LIST OF ILLUSTRATIONS

Figure 1-1 – Compression Cycle	7
Figure 1-2 – Package Illustration (Air-Cooled) – External Details	8
Figure 1-3 – Package Illustration (Water-Cooled) – External Details	10
Figure 2-1 – Typical Compressor Room	13
Figure 2-2 – Package Maximum Current Consumption Summary	16
Figure 2-3 – Line Reactor Sizing Recommendations	17
Figure 3-1 – Motor Fan Rotation Check.....	20
Figure 4-1 – Electrical Enclosure Hardware	26
Figure 4-2 – Piping And Instrumentation Illustration	29
Figure 4-3 – Wiring Diagram – (Air-Cooled) 460V - Single-Stage VS Control	30
Figure 4-4 – Wiring Diagram – (Water-Cooled) 460V - Single-Stage VS Control	34
Figure 4-5 – Wiring Diagram – (Air-Cooled) 575V – Single Stage VS Control.....	38
Figure 4-6 – Wiring Diagram – (Water-Cooled) 575V – Single Stage VS Control.....	42
Figure 5-1 – Checking Oil Level.....	49
Figure 5-2 – Changing Oil Filter	49
Figure 5-3 – Thermostatic Mixing Valve Element	50
Figure 5-4 – Pressure Dew Point Of Compressed Air	51
Figure 5-5 – Changing Oil Coalescing Element.....	53
Figure 6-1 – Air Flow Chart.....	55
Figure 6-2 – Cooler Housing Side Covers	56
Figure 6-3 – Water-Cooled Heat Exchanger Coolant Requirements	57
Figure 6-4 – Water Control Valve	58
Figure 6-5 – Water Separator And Drain	59
Figure 6-6 – Water Separator And Drain Details	59
Figure 7-1 – Air Filter (Standard)	61
Figure 8-1 – Coupling Components	63
Figure 8-2 – Coupling Element	64
Figure 8-3 – Motor Removal Hardware.....	64
Figure 8-4 – Coupling Removal Tool – VS40 Model Shown	66
Figure 8-5 – Location Airend Coupling Hub Installation Tool – VS40 Model Shown.....	67
Figure 8-6 – Locating Motor Coupling Hub Installation Tool – VS40 Model Shown.....	67
Figure 9-1 – Minimum Discharge Pressure/Check Valve	69
Figure 10-1 – Inlet Control Valve	70

SECTION 1 GENERAL INFORMATION

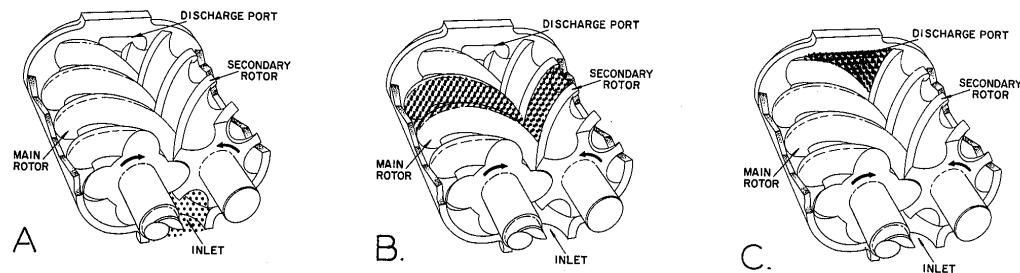

B74959A

Figure 1-1 – COMPRESSION CYCLE

COMPRESSOR – Your Gardner Denver Rotary Screw package is fitted with one (1) single stage, positive displacement rotary compressor using meshing helical rotors to effect compression. Each pair of rotors is supported between high capacity anti-friction bearings located outside the compression chamber. Single cylindrical roller bearings are used at each end of the rotors to carry the radial loads. An additional angular contact ball bearing is located at the discharge end of each rotor to carry axial thrust loads. The main rotor sits next to its gate companion, in a side-by-side configuration.

COMPRESSION PRINCIPLE (Figure 1-1) - Compression is accomplished by the main and gate rotors synchronously meshing in a one-piece cylinder. The main rotor has four (4) helical lobes, 90° apart, which mesh with five (5) helical grooves, 72° apart, on its matching gate rotor.

The air inlet port is located on top of the compressor cylinder, and the discharge port is located below the compressor cylinder. The compression cycle begins as the rotors unmesh at the inlet port and air is drawn into the cavity between the main rotor lobes and gate rotor grooves (A). When the rotors pass the inlet port cutoff, air is trapped in the interlobe cavity and flows axially with the meshing rotors (B). As meshing continues, more of the main rotor lobe enters the gate rotor groove, normal volume is reduced and pressure increases.

Oil is injected into the cylinder to remove the heat of compression and seal internal clearances. Volume reduction and pressure continues to increase until the air/oil mixture trapped in the interlobe cavity by the rotors passes the discharge port (C). Each rotor cavity follows the same “fill-compress-discharge” cycle in rapid succession to produce a discharge air flow that is continuous, smooth and shock free.

AIR FLOW IN THE COMPRESSOR SYSTEM (Figure 4-2, page 29) - Air enters the air filter and passes through the inlet control (poppet) valve to the compressor inlet flange. After compression, the air/oil mixture enters the oil reservoir where most of the entrained oil is removed by change of direction and impingent. It is further removed by centrifugal action and drained down into the reservoir. The air and remaining aerosols pass into twin coalescing elements where the oil is captured and drained through a drain line back into a lower pressure region of the compressor. The nearly oil-free air passes through the minimum pressure valve, aftercooler, optional moisture separator, and finally to the distribution network.

LUBRICATION, COOLING AND SEALING (Figure 4-2, page 29) - Oil is forced by differential pressure from the oil reservoir through the oil cooler, servo-driven oil mixing valve, oil filter, and enters the compressor. A portion of the oil is directed to internal passages within the compressor to lubricate the bearings and shaft oil seals. The balance of the oil is injected into the compressor rotors to remove the heat of compression, seal internal clearances and lubricate the rotors.

302CGD804-D
 (Ref. Drawing)
 Page 1 of 2

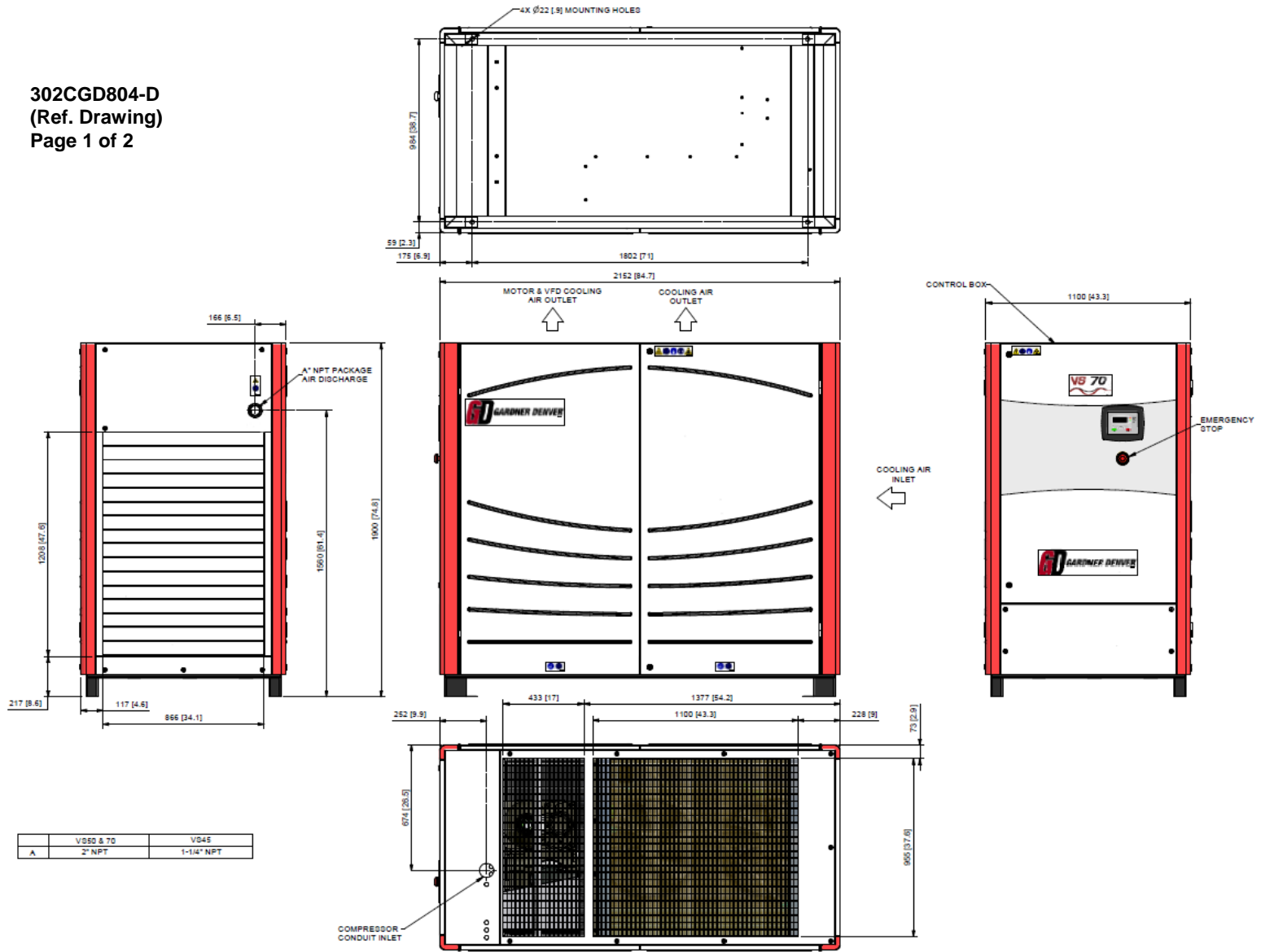
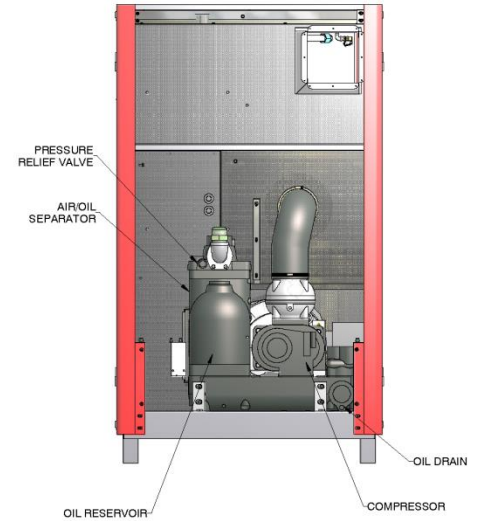
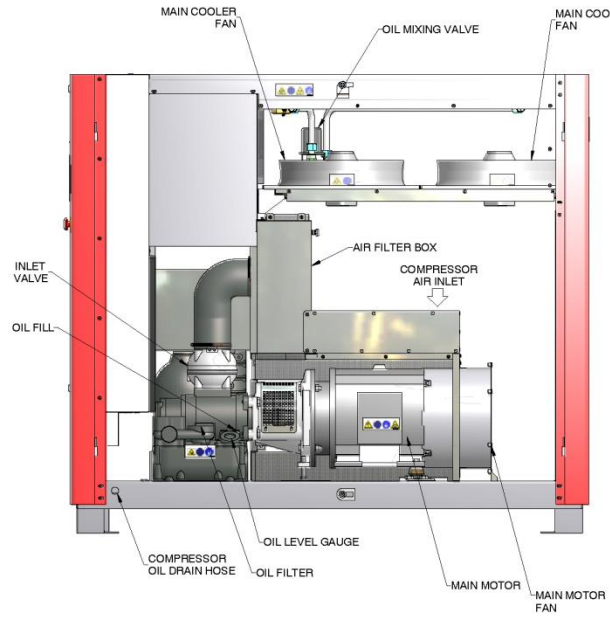
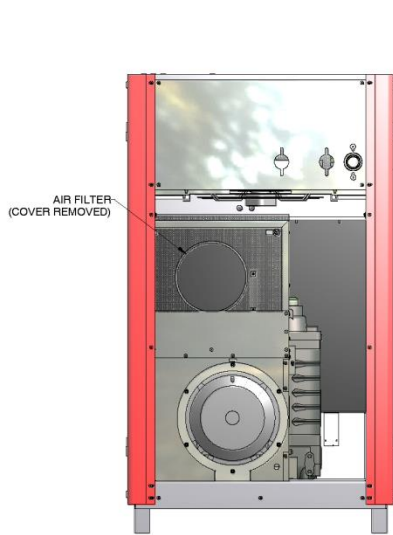
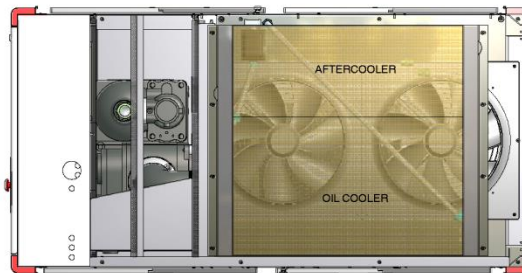

Figure 1-2 – PACKAGE ILLUSTRATION (AIR-COOLED) – External Details



302CGD804-D
(Ref. Drawing)
Page 2 of 2



303CGD804-C
(Ref. Drawing)
Page 2 of 2

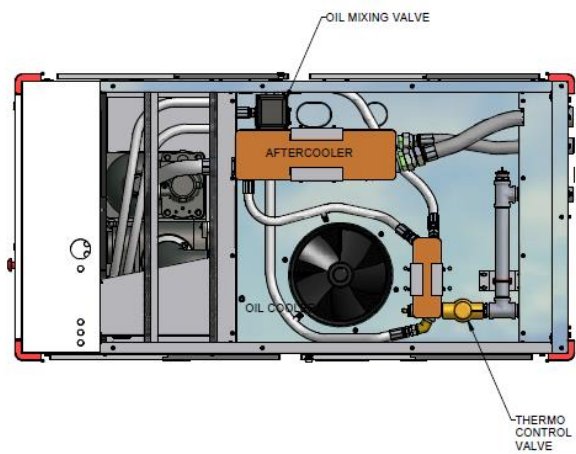
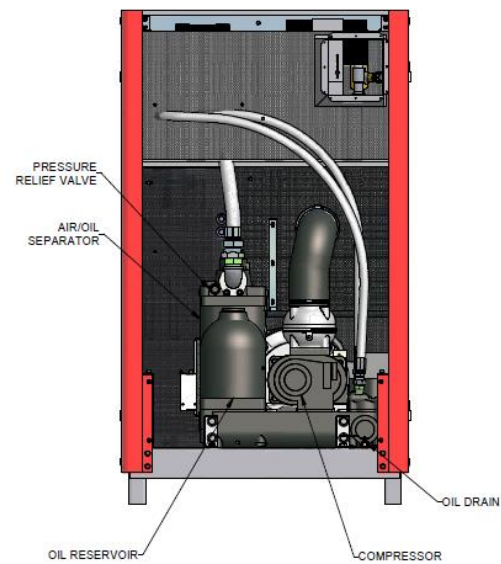
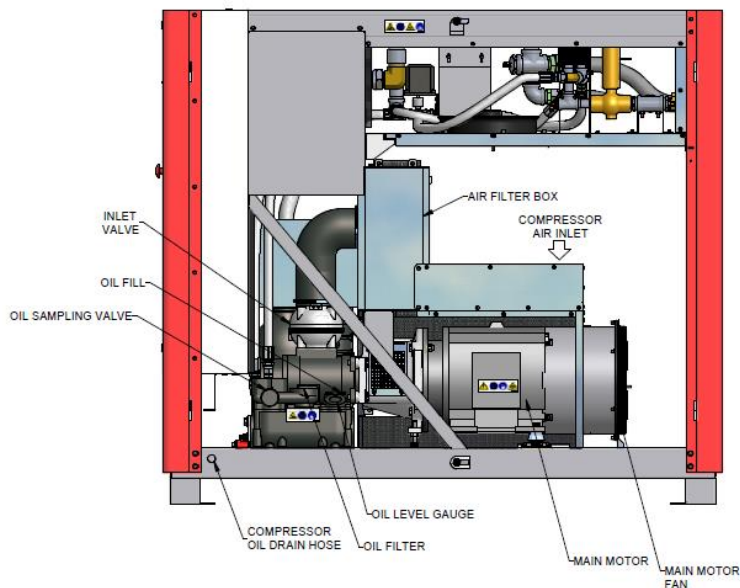
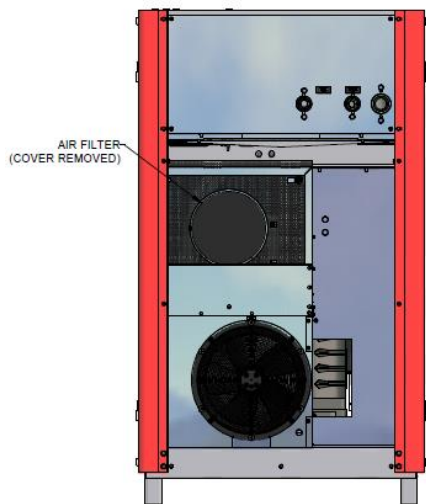

SECTION 2 INSTALLATION

GENERAL - On receipt of the unit, check for any damage that may have been incurred during transit. Report any damage or missing parts as soon as possible.



Do not electric weld on the compressor or base; bearings can be damaged by passage of current.

LIFTING UNIT - Proper lifting and/or transporting methods must be used to prevent damage. Lifting slots are provided in the base for tow motor use. The unit may also be moved into location by rolling on bars.



Lift compressor package by base only. Do not use other places such as motors, compressors or discharge manifold piping as lifting points.

The eyebolts or lugs provided on the motors are for lifting the motors only and should not be used to lift any additional weight. All eyebolts must be securely tightened. When lifting the motors, the lifting angle must not exceed 15 degrees. Failure to observe this warning may result in damage to equipment or personal injury.



Compressor, air/oil reservoir, separator chamber and all piping and tubing may be at high temperature during and after operation.

LOCATION - The compressor package shall be installed in a clean, well-lighted, well-ventilated area with ample space all around for maintenance. Select a location that provides a cool, clean, dry source of air. In some cases it may be necessary to install duct works to reach a source of adequate cooling air or to direct cooling air in and out of the compressor package, to prevent recirculation (e.g., hot cooling air entering the fresh air inlet). The package is designed to operate at ambient temperatures ranging from 40°F to 113°F (at up to 1000 meter elevation). Contact Gardner Denver for package operation at conditions exceeding the stipulated values.

A typical ventilation arrangement is shown in Figure 2-1.

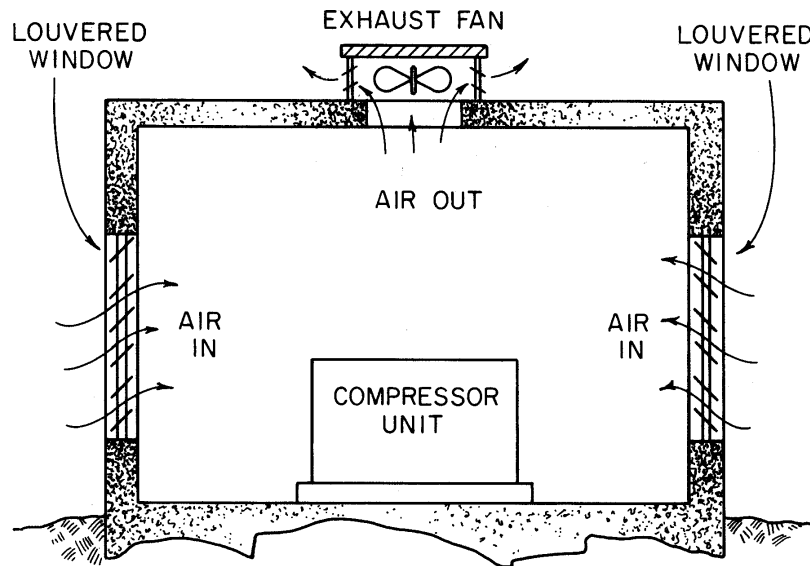

A75119

Figure 2-1 – TYPICAL COMPRESSOR ROOM

When selecting the compressor package location, be aware that its noise level may increase above its advertised free-field condition by reflections from nearby objects (e.g., walls, machinery, etc) or by noise from nearby machinery.

Air-Cooled Units - A combination oil/air cooler is supplied as standard equipment on all air-cooled packages. The heat exchangers require sufficient cooling air flow to operate efficiently – please refer to Section 6, Fig 6-1 of this manual for detailed instructions on the operation and maintenance of air-cooled heat exchangers, including minimum heat exchanger cooling and enclosure ventilation requirements.

Cooling air for the heat exchangers, main motors, and electronics box is drawn in at the intake grill end of the enclosure and is exhausted through a roof vent. Refer to Package Illustrations on Figure 1-2, page 8, for hardware details.

Do not block flow of air entering or exiting the enclosure - allow a minimum of 3-1/2 feet (1.1 m) clearance to the nearest obstruction all around and on top.

Water-Cooled Units – Separate brazed plate-type coolers for air and oil services are supplied on water-cooled packages. The heat exchangers require sufficient cooling water flow to operate efficiently – please refer to Section 6 of this manual for detailed instructions on the operation and maintenance of water-cooled heat exchangers, including minimum cooling water flow requirements.

Air for motor cooling and for the compressor intake is drawn in at the intake grill end of the enclosure and exhausted via a smaller roof vent – refer to Section 6 of this manual for enclosure ventilation requirements. Refer to Package Illustrations on Figure 1-3, page 10, for hardware details.

Do not block flow of air entering or exiting the enclosure - allow minimum of 3-1/2 feet (1.1 m) clearance to the nearest obstruction all around and on top.

FOUNDATION - The Gardner Denver Rotary Screw compressor requires no special foundation, but should be mounted on a smooth, solid surface and as near level as possible. Temporary installation may be made at a maximum 10° angle lengthwise or 10° sidewise.

Mounting bolts are not normally required. However, installation conditions such as piping rigidity, angle of tilt, or danger of shifting from outside vibration or moving vehicles may require the use of mounting bolts and shims to provide uniform support for the base.

OIL RESERVOIR DRAIN – Sump drain port, located near the oil filter, is 9” above the floor level. If this is not sufficient to conveniently drain the oil, other methods are:

1. Elevate the compressor unit on a suitable structure to obtain the desired drain height.
2. Construct an oil sump or trough below the floor level and pump or bail the drained oil.
3. Pump oil from the reservoir filler opening or drain to a container.

ENCLOSURE - The compressors, electric motors and oil/air cooler assembly are mounted inside the enclosure. Service doors are provided for maintenance access. Be sure to allow enough space around the unit for the doors to open completely.

To remove the enclosure doors, open the door and lift it up slightly to disengage the hinges.

CAUTION

Ducting may be required on air-cooled enclosed machines.

DANGER



Do not operate the compressors with the fan or coupling guard removed. Exposed fan and couplings may cause personal injury.

INSTALLATION FOR COLD WEATHER OPERATION It is recommended that the unit be installed inside a shelter that will be heated to temperatures above freezing (40° F, 5° C). This will eliminate many of the problems associated with operating units in cold climates where freezing rain, drifting snow, freezing condensate and bitter cold temperatures are encountered.

Unsheltered (outside) installations should be avoided whenever possible. Installation next to a heated building where enough heat can be used to keep the compressor room above freezing will save many complications in the operation and installation of the unit.

Refer to Engineering Data Sheet 13-9-411, available from an authorized Gardner Denver distributor, for the advantages of using the heat recovered from rotary compressors. This heat recovery could easily pay for an adequate shelter for the unit.

AUXILIARY AIR RECEIVER - An auxiliary air receiver is not required if the piping system is large and provides sufficient storage capacity to prevent rapid cycling. An adequate receiver capacity for the VS units is ½ gallon for each cfm delivered by the compressor package.

OPTIONAL MOISTURE SEPARATOR/TRAP – The unit can be provided with an optional stand-alone combination moisture separator and trap that is field-installed downstream of the aftercooler. Note that this device is not used on packages equipped with integrated dryers.

CONTROL PIPING - Control piping is not necessary since the Gardner Denver compressor package is factory wired and piped for the control system specified.

INLET LINE – The air filter assembly used in the VS compressor package is not suitable for relocation, as its housing assembly is an integral part of the enclosure sheet metal components. See LOCATION comments on this section of the manual for duct work recommendations to bring in ventilation air.

DISCHARGE SERVICE LINE - The discharge service line connection on both water-cooled and air-cooled units is located at the upper right-hand area of the intake grill side of the enclosure. Gardner Denver compressor packages are inherently isolated from the service line by their own minimum pressure/check valves. Installer or end user must ensure that other compressors that are piped into a common pipe manifold with the Gardner Denver compressor package are each provided with an isolation check valve. It is recommended that an additional receiver be installed between the rotary screw and reciprocating compressors sharing a common pipeline. Do not install another check valve in the unit's discharge line as operational upsets will occur.



Discharge air used for breathing will cause severe injury or death.

Consult filtration specialists for additional filtration and treatment equipment to meet health and safety standards.

BLOW DOWN VALVE PIPING – The blow down valve is vented between the air filter and inlet valve, thus avoiding the need of any external pipe work.

WATER PIPING (Water-Cooled Heat Exchanger Models Only) - On machines equipped with water-cooled heat exchangers, the water inlet and outlet connections are located next to air discharge connection.



It is mandatory that any water-cooled unit be installed in a shelter heated to temperatures above freezing (40°F., 5°C).

Please refer to Section 6 of this manual for detailed instructions on the installation, operation and maintenance of the water-cooled heat exchangers.

ELECTRICAL WIRING - The compressor package is (internally) factory wired for use with the voltage specified on the order - it is only necessary to connect power supply and ground wires to the provided wire terminal blocks.



Electrical shock can cause injury or death. Open main disconnect switch, lockout and tagout before working on control box.

Gardner Denver Guidelines for proper wiring, grounding and feed power conditioning - This compressor package is provided with a variable speed drive (VFD) to control compressor motor. The indicated Gardner Denver guidelines for proper wiring, grounding, and feed power conditioning must be followed in order to protect the VFD electronics. Failure to do so will void your warranty.

Electrical Wire Sizing – A certified electrician familiar with National Electric Codes and applicable local codes shall size the electrical power wires serving the compressor package. Refer to Figure 2-2, for a summary of maximum package current consumption values.

460 - 575 VOLT, VS-45, VS-50 and VS-70 MINIMUM COPPER SUPPLY WIRE RECOMMENDATIONS

460 Volt					
APEX VS 45 through VS 70 Minimum Copper Supply Wire Recommendations					
Model	Minimum Supply Conductor Ampacity	Minimum 75°C Copper Wire Sized @ 30°C	Minimum 75°C Copper Wire Sized @ 40°C	Minimum 75°C Copper Wire Sized @ 45°C	Notes
VS 45	117	1	1/0	1/0	
VS 50	140	1/0	2/0	2/0	
VS 70	194	3/0	4/0	250	
575 Volt					
VS 50	94	3	2	2	
VS 70	120	1	1/0	1/0	

Notes: Wire sizes are per Table 310.15(B)(16) in the National Electrical Code (NEC)

[1] 2/0 and 3/0 wire sized with derate for two parallel sets of conductors in a single conduit.

The appropriate installation and use of 75°C wire is the responsibility of the electrical professional(s) performing the installation and must be per NEC, local and state regulations as allowed. All of the above recommended minimum wire sizes are based on all terminal connections being rated at 75°C minimum temperature rating and copper wire run lengths of 100 feet or less. Please note that all UL-508A listed control panels are rated for 40°C ambient conditions.

Figure 2-2 – PACKAGE MAXIMUM CURRENT CONSUMPTION SUMMARY

Electrical Wire Routing – Routing of the electrical power wires into the electrical hardware enclosure is best done through its roof area.

Line Reactor – A line reactor provides conditioning of the electrical power supply to the compressor package by attenuating noise and fluctuations. It shall be required in your particular application if any of the following conditions exist:

- Transformer KVA is greater than recommended – see Figure 2-3, page 17.
- Line has switched Power Factor correction capacitors.
- Existing line reactor not properly sized – see Figure 2-3, page 17.
- Other large loads on the same power feed as the compressor.

GD Model	Volts	VFD HP RATINGS	Max KVA	3% Line Reactor GD Part Number
VS45	400/480	60	900	90500140
VS50	400/480	75	1000	90500141
VS70	400/480	100	1000	90500142

Figure 2-3 – LINE REACTOR SIZING RECOMMENDATIONS

GROUNDING – Equipment must be properly grounded in accordance with the National Electrical Code and/or applicable local codes.



Failure to properly ground the compressor package could result in injury or death. Install ground wiring in accordance with the National Electrical Code and any applicable local codes.

MOTOR LUBRICATION - Long time satisfactory operation of an electric motor depends in large measure on proper lubrication of the bearings. Refer to Section 13 page 76 of this manual for complete motor lubrication specifications and details.

SECTION 3 STARTING & OPERATING PROCEDURES

NOTICE



Read the Operator's Manual before operating the compressor.

PRESTART-UP INSTRUCTIONS - A new unit as received from the factory has been tested and then prepared for shipping only. **DO NOT** attempt to operate the unit until checked and serviced as follows:

1. **Compressor Oil** - Check the oil level in the sump – with unit stopped, the oil level should be within the white-colored central portion of the measuring rod visible through the site glass. Add oil, with unit stopped and depressurized, when the oil level reaches the lower red-colored portion of the measuring rod. Do not mix different type oils. When the unit is shipped, it is filled with Gardner Denver AEON™ 9000SP lubricating coolant, suitable for the first 8000 hours under normal operating conditions.

NOTICE

Regular maintenance and replacement at required intervals of the oil filter, air filter and air/oil separator is necessary to achieve maximum service and extended drain intervals of AEON 9000SP synthetic lubricating coolant. Use only genuine Gardner Denver filters designed and specified for this compressor.

NOTICE

Whenever the oil is drained from the compressor (e.g., due to oil change or compressor replacement), a minimum amount must be replenished to lubricate and seal rotors during the start-up phase. Temporarily remove the flexible hose between the air filter assembly and the intake poppet valve and add 1 gallon of oil through the intake valve opening.

 **DANGER**



Before removing the oil filler plug, always stop the unit and release air pressure, lockout and tagout the power supply to the compressor package. Failure to release pressure or properly disconnect the power may result in personal injury or death.

2. **Air Filter** - Inspect the air filter to be sure it is clean and the assembly is sealed tight. Refer to Section 7, "Air Filter", for complete servicing instructions. Be sure the inlet line is clean and sealed tight.
3. **Couplings** - Check setscrews for tightness. See Section 8.
4. **Piping** - Refer to Section 2, "Installation," and make sure piping meets all recommendations.

Electrical - Check the wiring diagrams furnished with the unit to be sure it is properly wired.

See Figure 4-3 thru

Figure 4-6, for general wiring diagrams and Section 2, for installation instructions. Make sure to check the wiring of the optional compressed air dryer, as it is serviced by an independent electrical power feed.

5. **Grounding** - Equipment must be properly grounded according to Gardner Denver Guidelines for proper wiring, grounding and feed power conditioning.

 **CAUTION**

Failure to properly ground the compressor package could result in controller malfunction.

NOTICE



Read the Operator's Manual before operating the compressor.

6. **Rotation** - Check for correct rotation of all electric motors:
 - Use controller "JOG MODE" to bump compressor motor. Proper rotation shall be clockwise when facing the compressor shaft end.

- Use Controller “JOG MODE” to bump heat exchanger cooling fan. Proper rotation shall be counterclockwise facing rear of fan drive motor.
- Use Controller “JOG MODE” to bump main motor cooling fan. Proper rotation is achieved when cooling air is discharged over the main motor body or when fan rotation matches that indicated by the arrow decal affixed to the fan hub, as viewed via the serrated cutout on the fan shroud. See Figure 3-1 for details.
- In case the main motor or any of the fan/motor combinations are replaced or disconnected from the package wiring system, their rotation must be verified. If the incorrect rotation is noted on any one electric motor, take the following steps to make the necessary correction:
 - Disconnect, lockout and tagout power supply to the compressor package.
 - Locate, within the electrical enclosure, the three (3) wires feeding power to the motor in question.
 - Loosen, reverse, and re-fasten the connections of any two (2) of the wires.
 - Re-energize compressor package and recheck rotation.

⚠ CAUTION

Operation with incorrect motor rotation can damage equipment and cause oil eruption from the compressor inlet. When checking motor rotation, induce minimum rotation (less than one revolution if possible). Never allow motor to reach full speed.

⚠ CAUTION

The compressor unit’s direction of rotation must be checked every time the compressor is reconnected to the power supply.

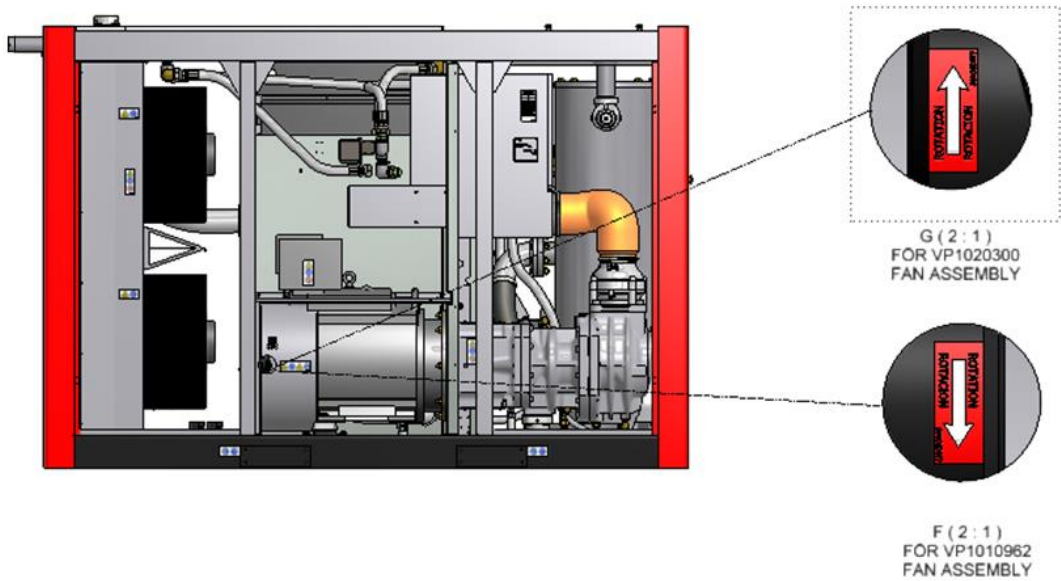



Figure 3-1 – MOTOR FAN ROTATION CHECK

7. **System Pressure** – For your convenience, the following excerpt from the Controller Manual 13-17-600 is presented to assist in programming the system pressure:

Quick Start Guide

Operation of the AirSmart controller is easy. Simply select a Target Pressure and then press the Run  button to start the compressor, no other settings are required. The Target Pressure comes preset from the factory at pressure as ordered. The Unload Pressure is preset to 10 psi higher. If a different pressure setting is desired, the following steps can be used as a guide.

- **Setting the Target Pressure**

The Target Pressure setting is used to set the operating point of the compressor. To make any adjustments in the operation of the compressor, the machine must be stopped and in the Ready mode. Stop the compressor by pressing the Stop/Reset  button. The front panel display should read “READY” on line 3.

```
0 PSI          75°F
10 HRS        AUTOMATIC
              READY
NO SERVICE ADVISORY
```

Next, press the Enter  button to access the Adjustment Menu tree

```
ADJUSTMENT MENU
OPERATION ADJUSTMENT
(SELECT SUB MENU)
```

Since the Target Pressure setting is under the Operation Adjustment menu, press Enter  again to access that sub-menu







```
OPERATION ADJUSTMENT
LANGUAGE-LANGUAGE
ENGLISH (US)
(SELECT PARAMETER)
```

The Target Pressure is the second item in the Operation Adjustment sub-menu so press the Down  button to navigate to the Target Pressure setting.

```
OPERATION ADJUSTMENT
TARGET PRESSURE
100 PSI
(SELECT PARAMETER)
```

To change the Target Pressure, press the Enter  button to edit the value.

```
OPERATION ADJUSTMENT
TARGET PRESSURE
100 PSI
(EDIT PARAMETER)
```

A flashing cursor will appear covering the least significant digit in the Target Pressure value, use the Plus  and Minus  buttons to change its value. Use the Right  and Left  buttons to move the cursor to other digits in the Target Pressure value. When the desired Target Pressure value is displayed, press the Enter  button to save the new value. Pressing the Stop/Reset  button will abort the change and restore the previous value.

In order to save the changes made to parameters, press the Stop/Reset button to go back to the heading of the current menu and then press the Stop/Reset button again. If parameter changes have been made, the following screen will appear.

**STORE MODIFIED
PARAMETERS?
STOP = NO
ENTER = YES**

To permanently save the changes that were made, press the Enter  button. If the Stop/Reset button is pressed, the parameter changes will be lost the next time the compressor power is turned off.

- **Setting the Unload and Load Pressure**

After setting the Target Pressure, set the Unload and Load Pressures values in a similar fashion. The Unload pressure is the third item in the Operation Adjustment sub-menu so press the Down  button to navigate to the Unload Pressure setting. The Unload Pressure will control at which pressure the compressor unload and stops.

**OPERATION ADJUSTMENT
UNLOAD PRESSURE
110 PSI
(SELECT PARAMETER)**

The Load pressure is the fourth item in the Operation Adjustment sub-menu so press the Down  button to navigate to the Load Pressure setting. The Load Pressure will control at which pressure the compressor will startup again after unloading.

**OPERATION ADJUSTMENT
LOAD PRESSURE
100 PSI
(SELECT PARAMETER)**



Operation at excessive discharge air pressure can cause personal injury or damage to equipment. Do not adjust the full discharge air pressure above the maximum stamped on the unit nameplate.

8. **Operating Mode** - Refer to Controller Manual 13-17-600 for more detailed information on the control system.
9. **Enclosure** - Check for damaged panels or doors. Check all screws and latches for tightness. Be sure doors are closed and latched.

STARTING THE UNIT - Observe the following starting procedures.

Unit Cold - If the unit is fitted with water-cooled heat exchangers, fully open water inlet valve(s). If the unit is located in a cold environment (e.g., ambient temperature below 40°F, 5 °C), the required external heat source must be energized prior to start. Press the red “STOP/RESET” button to clear any conditions (e.g., “Loss of Power” when electrical system was energized) and start the unit by pushing the green “START” button. Since the unit is equipped with a minimum pressure valve (60 psig, 4.1 bar), no special procedure to maintain minimum reservoir pressure is required.

Unit Hot - Start-up instructions are the same as that of a cold start.

Compressed Air Dryer (Optional) – The dryer module is fed electrical power from a separate (off-package), disconnect provided by the end user – it must be engaged prior to dryer operation. Relay contacts, operated by the package AirSmart controller, engage and disengage the dryer from the external power source. The dryer is turned on when the “START” button is pressed, which also starts the compressor system. The dryer remains powered until the “STOP” button is pressed and remains in operation during low air demand periods that temporarily shut down the compressor. Please refer to the dryer manual 13-18-602 for all installation, operation and maintenance instructions.

DAILY CHECK - Refer to Section 14, “Maintenance Schedule”.

STOPPING THE UNIT - Press “STOP-RESET” button. The oil reservoir will automatically blow down, as the main motor is de-energized. If the unit is a water-cooled heat exchanger type, close any manual water inlet valves after unit has stopped. Be sure external heat is turned on if below 40°F (5°C),



Automatic restarting or electrical shock can cause injury or death. Disconnect, lockout and tagout the unit from the power supply and any other circuits before servicing unit.



When the pressure relief valve opens, a stream of high velocity air is released, resulting in a high noise level and possible discharge of accumulated dirt or other debris. Always wear eye and ear protection and stand clear of the discharge port when testing the pressure relief valve to prevent injury.

CAUTION

Never paint, lubricate or alter a pressure relief valve. Do not plug vent or restrict discharge.

⚠ DANGER



Operation of the unit with improper pressure relief valve setting can result in severe personal injury or machine damage. Ensure properly set valves are installed and maintained.

SECTION 4 CONTROLS & INSTRUMENTATION

GENERAL DESCRIPTION - The Gardner Denver rotary screw compressor package is pre-wired with all electrical components suitable for the voltage and horsepower at time of order. It is necessary only to connect the compressor unit to the correct power supply and to the shop air supply network - and to the appropriate water supply if using the water-cooled variant. A standard single stage compressor package consists of unitized module that houses a single rotary screw compressor, oil sump, separation, filtering, and internal injection delivery system, a main drive motor, a VFD, an oil/air cooling system, IP54 electrical enclosure to house VFD on common controller and a sound-attenuating enclosure. The various control devices employed are described as follows:

Controller - The compressor package features the AirSmart controller, which integrates all the control functions under microprocessor control. Controller functions include safety and shutdown, compressor regulation, operator control and advisory/maintenance indicators. The keypad and display provides a logical and easily operated control of the compressor and indication of its condition. The controller is factory adjusted for the compressor package, but allows tuning for specific applications.

NOTICE



Read the Operator's Manual before operating the compressor. It is critical that the detailed instructions for the controller, found in the controller manual 13-17-600, are read and understood. Once the appropriate parameters have been selected into the controller, compressor operation may commence. For your convenience, a "Quick Start" excerpt from the controller manual is shown on Section 3.8

Press the red "STOP/RESET" button to clear any conditions (e.g., "Loss of Power" when electrical system was energized) and start the unit by pushing the green "START" button. Since the unit is equipped with a minimum pressure (60 psig, 4.1 bar) valve, no special procedure to maintain minimum reservoir pressure is required.

Main VFD and Motor – The compressor is driven by an inverter-duty electric motor, which in turn is energized by a pulse-width modulated, variable frequency drive (commonly referred to as VFD). This combination of components enables the compressor package to match the supply of compressed air (e.g., flow capacity) to meet the customer's demand in real time and in a step-less fashion. The operational logic which governs the drive and motor-combination is supplied by the AirSmart controller and it is based on the following basic rules:

- The speed of the compressor is modulated (e.g., increased or decreased) until the desired system discharge pressure is achieved.

The drive shares a common IP54 protected enclosure with the AirSmart controller and assorted electrical hardware. Ventilation for the electronics is supplied forced air delivered by the heat exchanger cooling fans and filtered by inlet and outlet filters. The motor is built with a TEFC protected frame and coupled to the compressor via a NEMA-D flange. The drive includes adequate current overload protection for its companion motor.

The drive and motor are designed to operate with 3ph-60Hz-460vac electrical power, which must be installed in accordance with local (site) Electrical Code requirements.

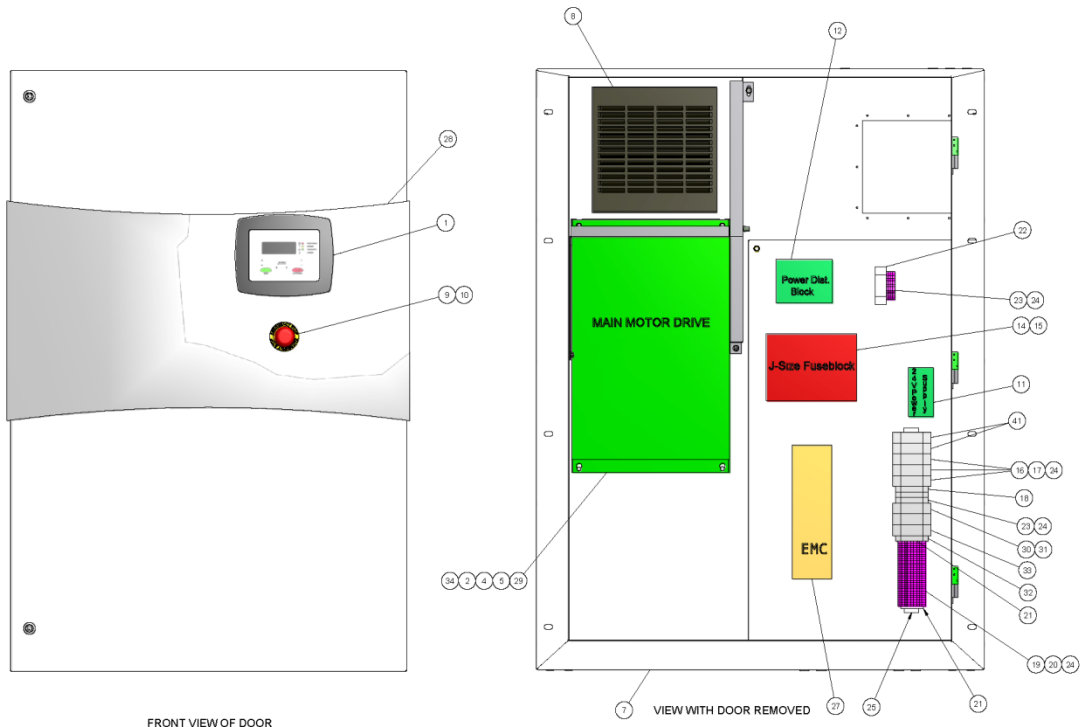

**308CGD810-E
(Ref. Drawing)**

ASSEMBLED CONTROL BOX WITH EMC FILTER.....
ASSEMBLED CONTROL BOX WITHOUT EMC FILTER

Ref. No.	Name of Part
1	AIRSMART CONTROL BOX
2	GRP-DRIVE (VS45-US).....
3	CABLE ASSEMBLY
4	SPLITTER CABLE
5	SCREW TERMINAL PLUG.....
7	CONTROL BOX ENCLOSURE
8	ELECTRICAL FILTER.....
9	OPERATOR
10	CONTACT BLOCK.....
11	POWER SUPPLY
12	POWER DIST BLOCK
13	TERMINAL LUG.....
14	FUSE HOLDER.....
15	FUSE
16	FUSE BLOCK
17	FUSE
18	RELAY
19	TERMINAL BLOCK.....
20	TERMINAL BLOCK.....
21	GROUND BLOCK
22	GROUND BLOCK
23	GROUND BLOCK
24	TERMINAL BLOCK.....
25	DIN RAIL
27	EMC FILTER
28	CONTROL BOX DECAL (not shown).....
29	NUT
30	FUSE BLOCK
31	FUSE
32	GROUND BLOCK.....
33	RELAY.....
34	RESISTOR
41	FUSE

Figure 4-1 – ELECTRICAL ENCLOSURE HARDWARE

Heat Exchanger Fan/Motor and Starter - The combination axial fan/motor (two units on VS50 and VS70, one unit on VS45) provides cooling air for the heat exchangers and electronics box. The starter provides control for the fan motor only, as the latter includes its own thermally-resettable, internal overload protection. These devices are designed to operate with 3 ph-60 Hz-460 vac electrical power – the necessary electrical wiring has been provided.

Main Motor Ventilation Fan/Motor and Starter – The combination axial fan/motor cools the main motor by blowing fresh air over its body. The starter provides control for the fan motor only, as the latter includes its own thermally-resettable, internal overload protection. These devices are designed to operate with 3 ph-60 Hz-460 Vac electrical power – the necessary electrical wiring has been provided.

Control Transformer - This device reduces the incoming power voltage to 110-120 volts for use by various control components (e.g., 24 vdc power supply, electrical enclosure cooling fans, etc.). Two primary fuses and one secondary fuse are provided for overload protection.

Power Supply (24vdc) - This device supplies electrical power to the AirSmart controller and various solenoid valves.

For Letter References A thru U below, see Figure 4-2, page 29.

Inlet (Poppet) Valve (B) – This device is located at the intake flange of the compressor. During compressor operation, the underside of the poppet is vented to atmosphere via a 3-way solenoid valve, allowing the poppet to fall (open) and feed fresh air to the compressor inlet. During stopped operation modes (e.g., commanded from keypad or initiated by protective shutdown), the 3-way solenoid valve feeds an air signal to the underside of the poppet, forcing it upward (close) and block off the compressor intake. This prevents trapped air and oil within the compressor from exiting through the inlet filter. See SECTION 10 for further details.

Minimum Discharge Pressure/Check Valve (G) – This device maintains a minimum pressure (60psig) within the air/oil reservoir, thus insuring (lubrication/cooling) oil injection flow into the compressors. It also prevents the back flow of compressed air from the customer's piping back into the compressor package when the compressor is not running. See SECTION 9 for further details.

The spring-loaded (and pneumatically assisted) piston does not allow the discharge of compressed air from the air/oil reservoir until the compressor builds up reservoir pressure beyond 80 psig. Beyond this pressure level, the valve remains fully open.

Oil Mixing Valve (L) – This device prevents the compressor from operating at a pressure and temperature combination that condenses water vapor in the oil system. The servo-driven, 3-way, ball valve mixes cooled and hot oil, prior to delivery to the oil filter and oil injection line, as commanded by an algorithm residing in the package controller. See SECTION 5 for further details.

Pressure Relief Valve (O) – This device protects the pressure containing components of the compressor package against high pressure exceeding 188.5 psig. See SECTION 11 for further details.

Pressure Regulator (S) – This device supplies the pneumatic signal to actuate the minimum pressure valve (G). The regulator is adjusted to achieve an opening pressure at the MPV of 80psig.

Inlet Feed Valve (C) - This (three-way solenoid) device supplies/vents the required pneumatic signal to actuate the inlet poppet valve. When energized, it opens (vents) the inlet poppet valve and when de-energized, it closes (pressurizes) it.

Ball Valve – Oil Drain (N) - This device allows the drainage of the oil charge held in the reservoir during oil change operation.

Blow Down Valve (P) - This (two-way solenoid) device vents compressed air from the air/oil sump. During compressor operation (e.g., compressors are running or they have temporarily stopped due to line pressure reaching unload pressure); the blow down valve remains energized (closed) and the air/oil reservoir remains pressurized. When compressor operation is halted (e.g., by use of the red "STOP" controller button, by loss of electrical energy, or by a shutdown condition), the valve is de-energized (normally open state) and the air/oil reservoir is blown down.

LEGEND:

- AIR
- - - OIL
- WATER (COOLING)
- - - WATER (CONDENSATE)

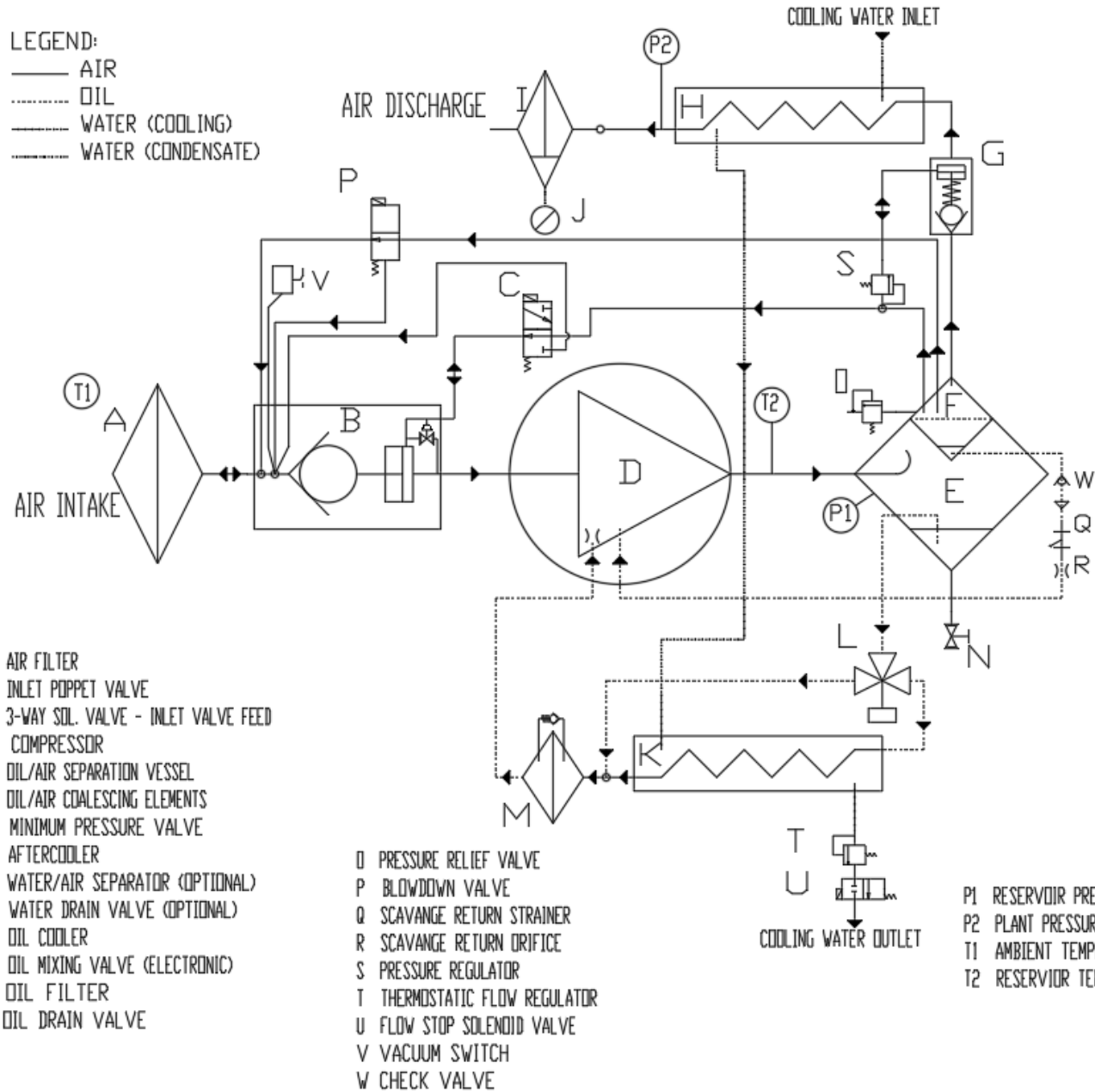

- A AIR FILTER
- B INLET POPPET VALVE
- C 3-WAY SOL. VALVE - INLET VALVE FEED
- D COMPRESSOR
- E OIL/AIR SEPARATION VESSEL
- F OIL/AIR COALESCING ELEMENTS
- G MINIMUM PRESSURE VALVE
- H AFTERCOOLER
- I WATER/AIR SEPARATOR (OPTIONAL)
- J WATER DRAIN VALVE (OPTIONAL)
- K OIL COOLER
- L OIL MIXING VALVE (ELECTRONIC)
- M OIL FILTER
- N OIL DRAIN VALVE

- O PRESSURE RELIEF VALVE
- P BLOWDOWN VALVE
- Q SCAVANGE RETURN STRAINER
- R SCAVANGE RETURN ORIFICE
- S PRESSURE REGULATOR
- T THERMOSTATIC FLOW REGULATOR
- U FLOW STOP SOLENOID VALVE
- V VACUUM SWITCH
- W CHECK VALVE

- P1 RESERVOIR PRESSURE TRANSDUCER
- P2 PLANT PRESSURE TRANSDUCER
- T1 AMBIENT TEMPERATURE THERMISTOR
- T2 RESERVOIR TEMPERATURE THERMISTOR

NOTE: OPTIONAL COMPRESSED AIR DRYER REPLACES ITEMS I AND J WITH BUILT-IN EQUIVALENTS

300CGD797-B
(Ref. Drawing)

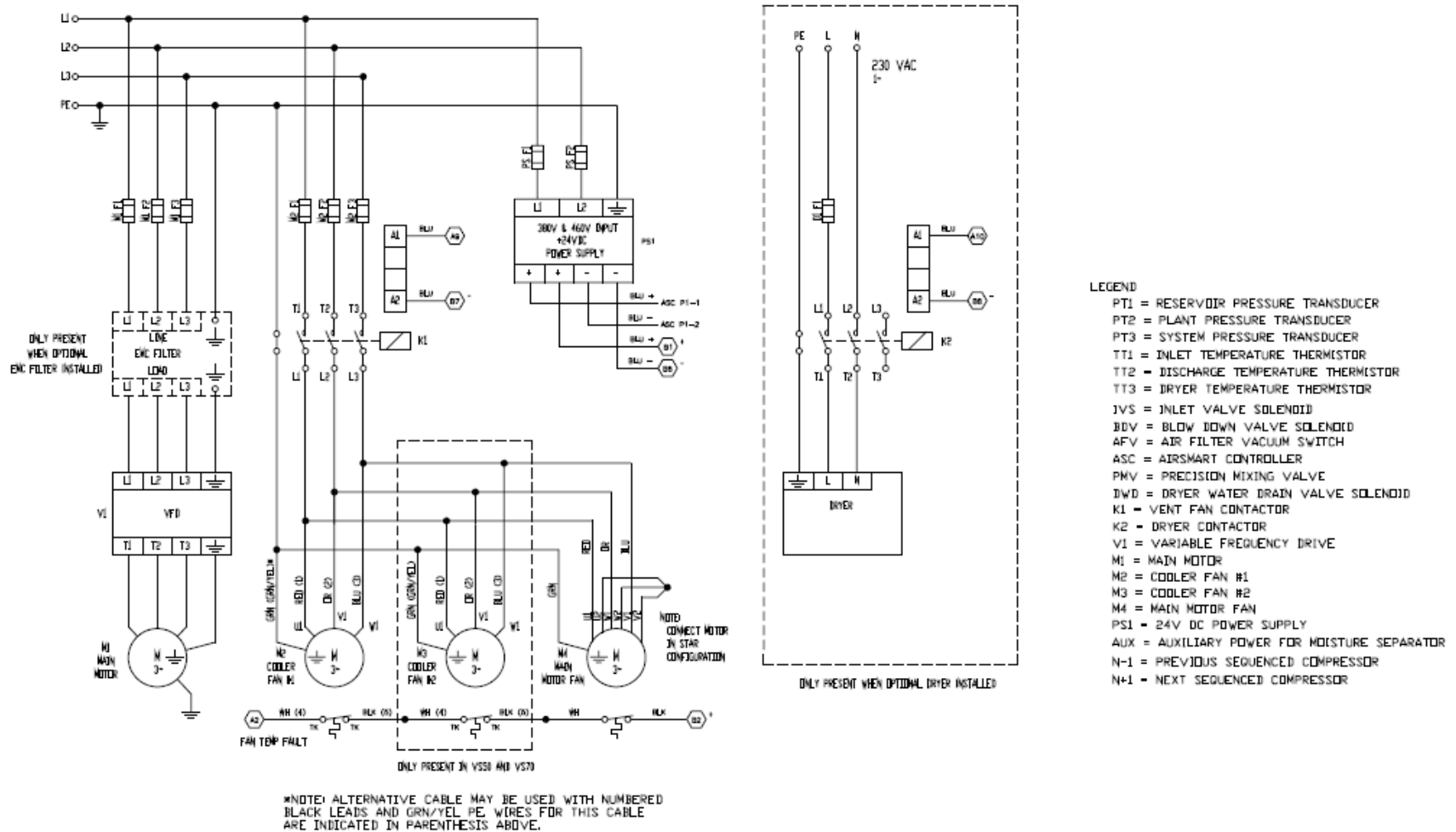
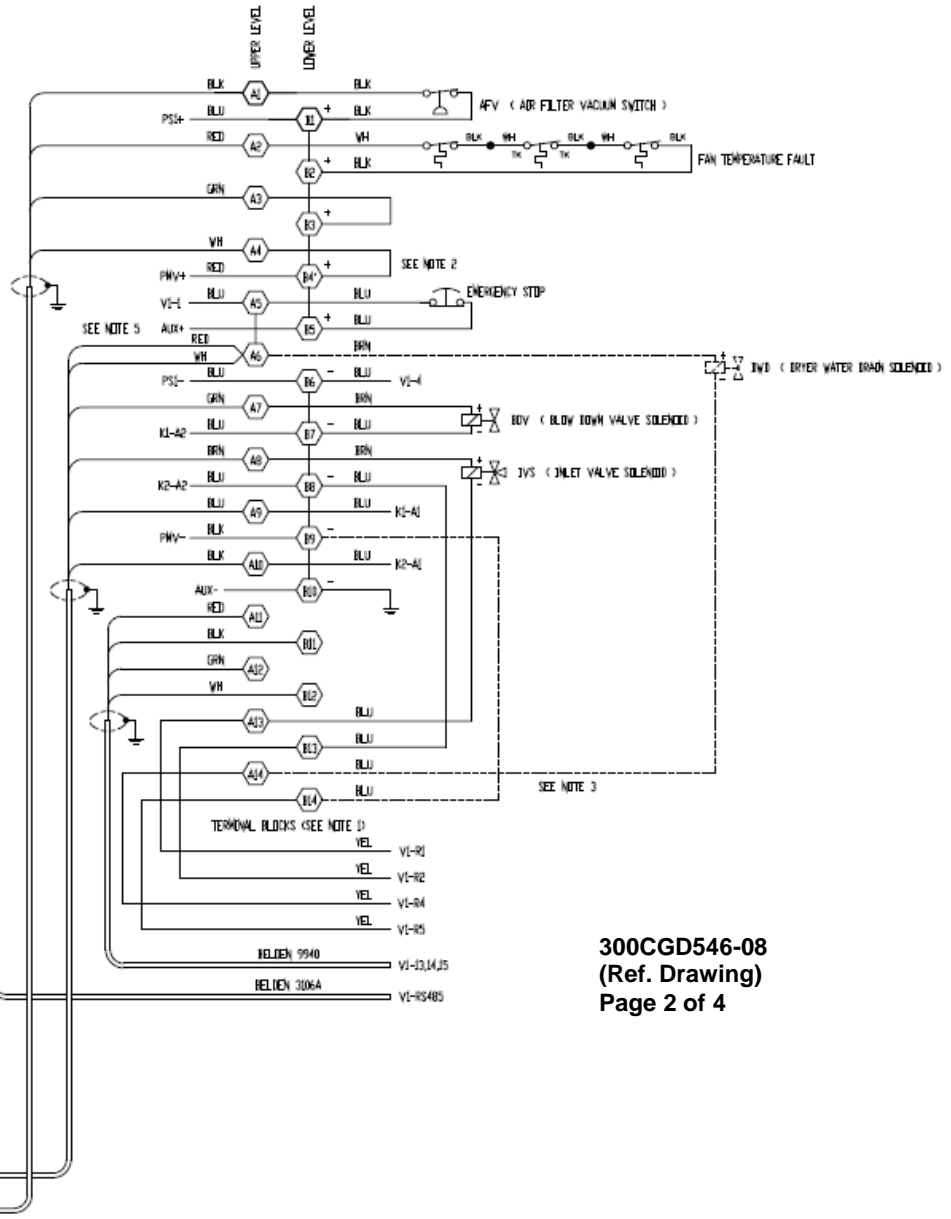
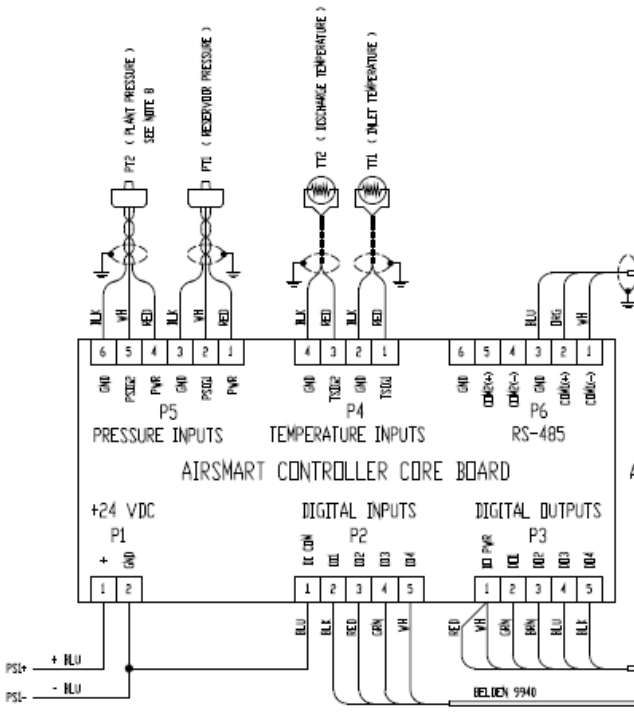
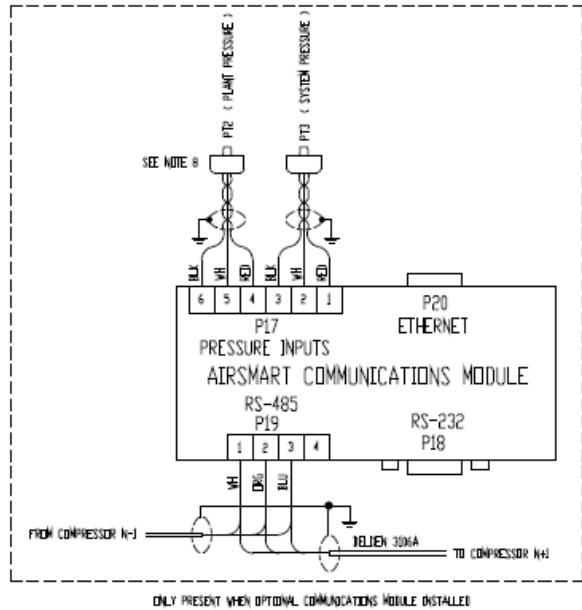
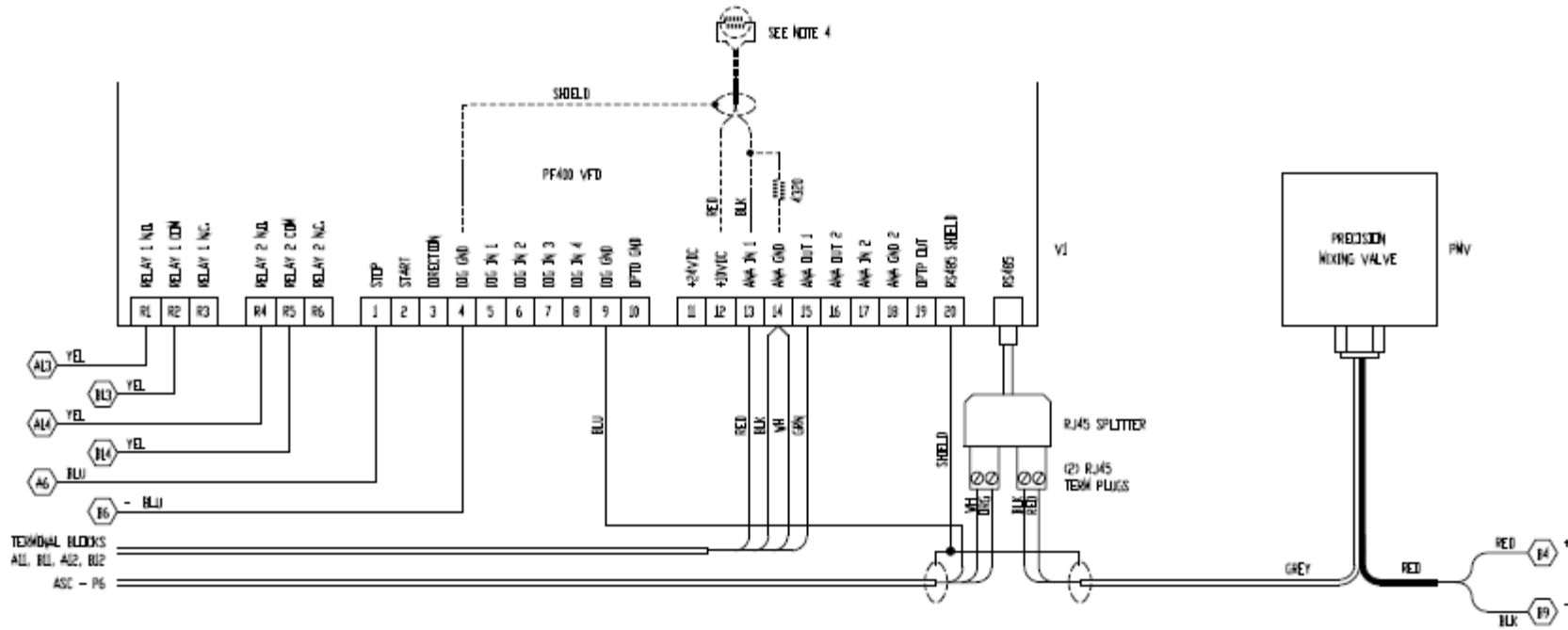

Figure 4-3 – WIRING DIAGRAM – (AIR-COOLED) 460V - Single-Stage VS Control



300CGD546-08
(Ref. Drawing)
Page 2 of 4



NOTES:

1. SHORTING JUMPERS INSTALLED ON TERMINALS BLOCKS AS FOLLOWS
 +24VDC - B1, B2, B3, B4, B5
 DC GND - B6, B7, B8, B9, B10
 E-STOP QUALIFIED +24VDC - A5, A6
2. FOR CONTROL BY REMOTE CONTACT, REMOVE JUMPER BETWEEN TERMINALS A4 AND B4 AND CONNECT N.C. SWITCH
3. WHEN DRYER IS NOT INSTALLED ADVISORY/SHUTDOWN ALARM CONTACT BETWEEN A14 AND B14 CONTACT RATING: N.O., 3A @ 30VDC, 3A @ 240VAC
4. WHEN DRYER THERMISTOR IS INSTALLED CONNECT RED THERMISTOR WIRE TO TERMINAL 12, CONNECT BLACK THERMISTOR WIRE TO TERMINAL 13, CONNECT 4320 OHM, 0.25W, 1% RESISTOR BETWEEN TERMINAL 13 AND TERMINAL 14.
5. AUXILIARY POWER FOR MOISTURE SEPARATOR NOT INSTALLED WHEN DRYER IS USED.
6. BACK PLATE MUST BE BONDED TO CONTROL BOX USING 4 AWG (MIN) BONDING STRAP.
7. DOOR MUST BE BONDED TO CONTROL BOX USING 10 AWG (MIN) BONDING STRAP.
8. WHEN COMMUNICATIONS MODULE IS INSTALLED AND PT3 IS INSTALLED, CONNECT PT2 TO P17, PINS 4-6.

300CGD546-08
 (Ref. Drawing)
 Page 3 of 4

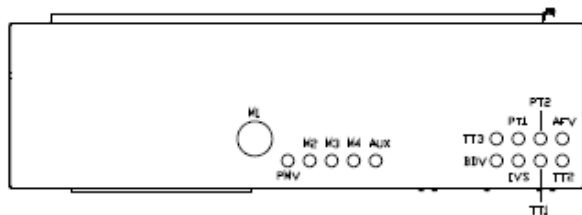
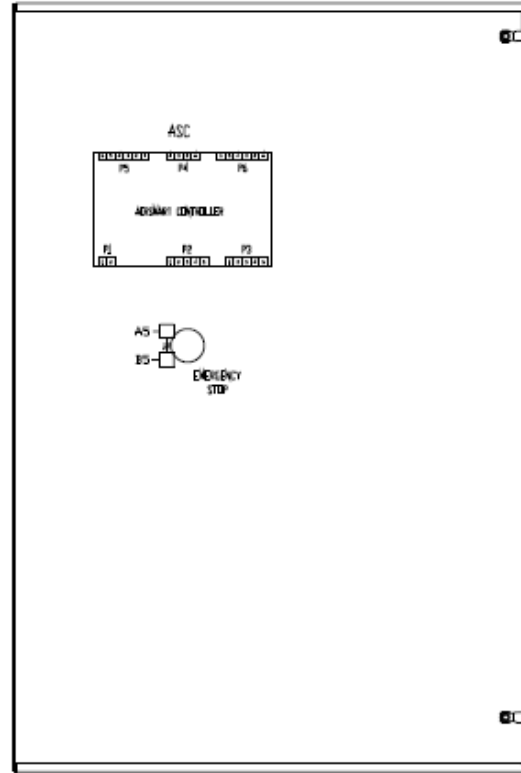
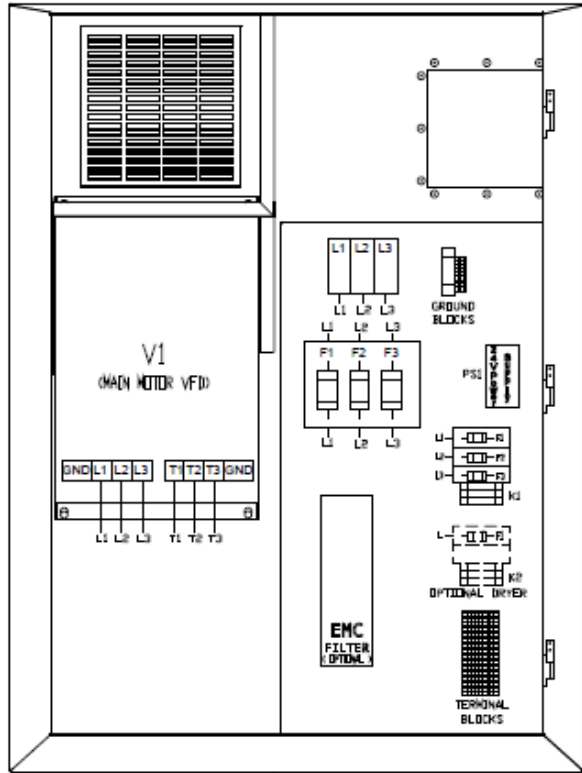
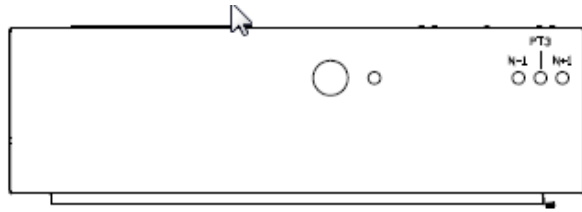

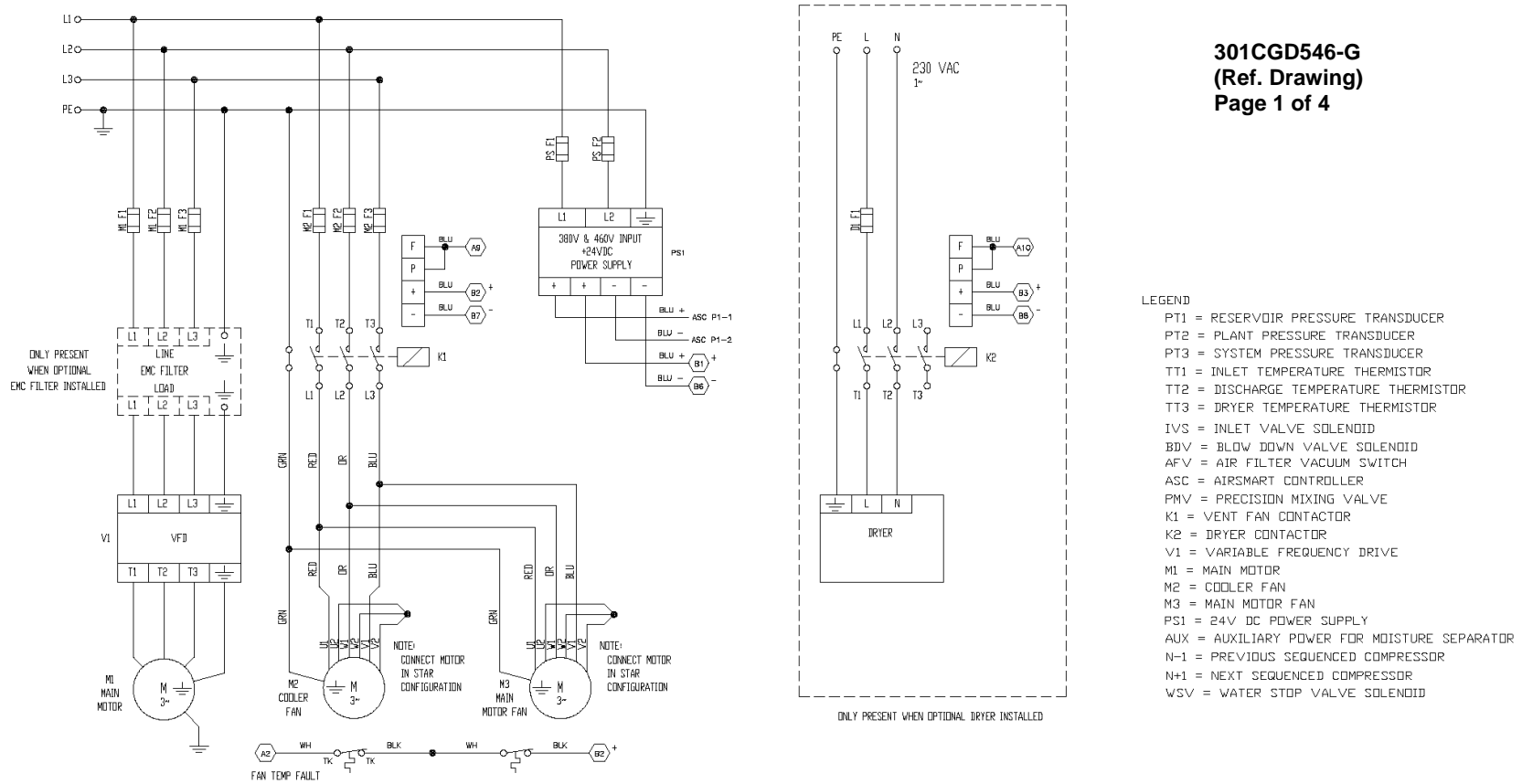
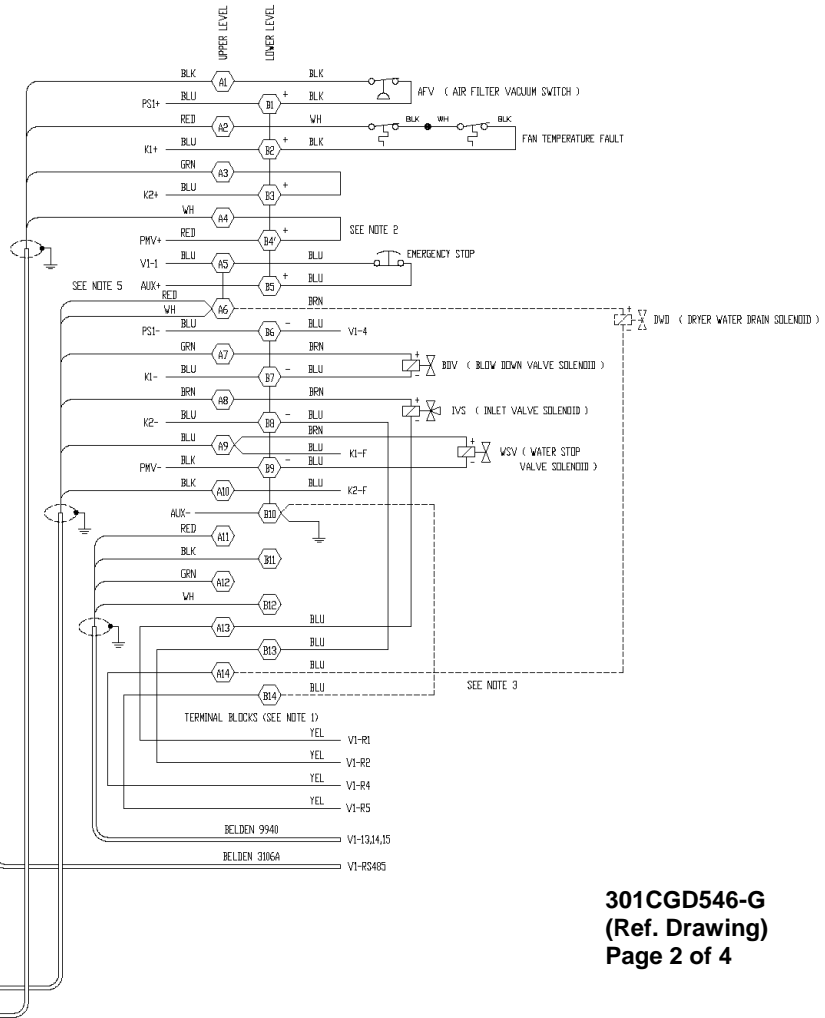
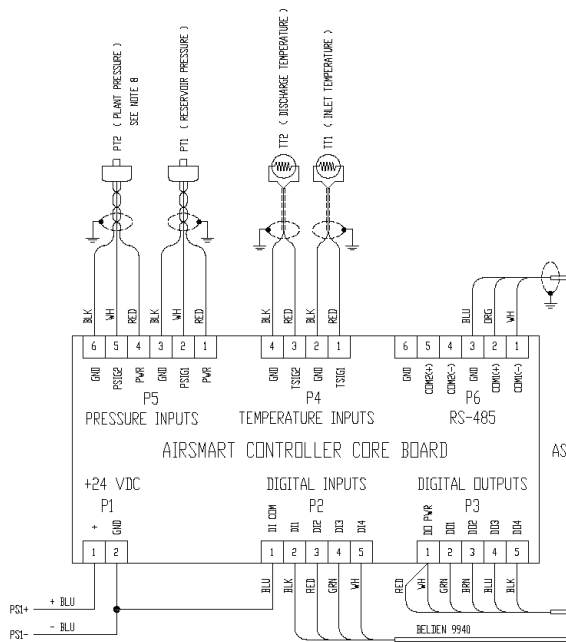
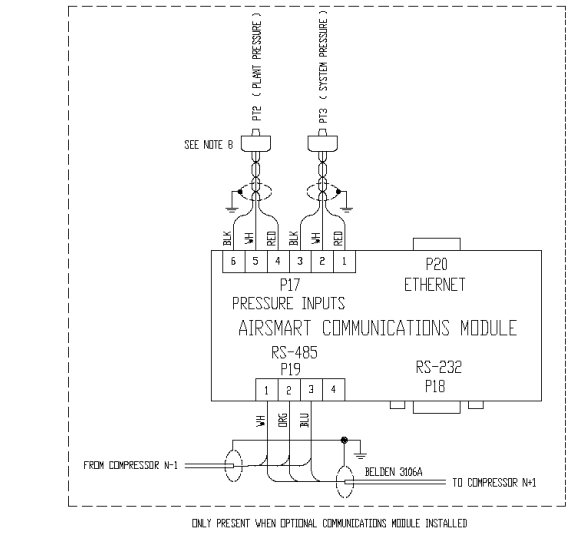
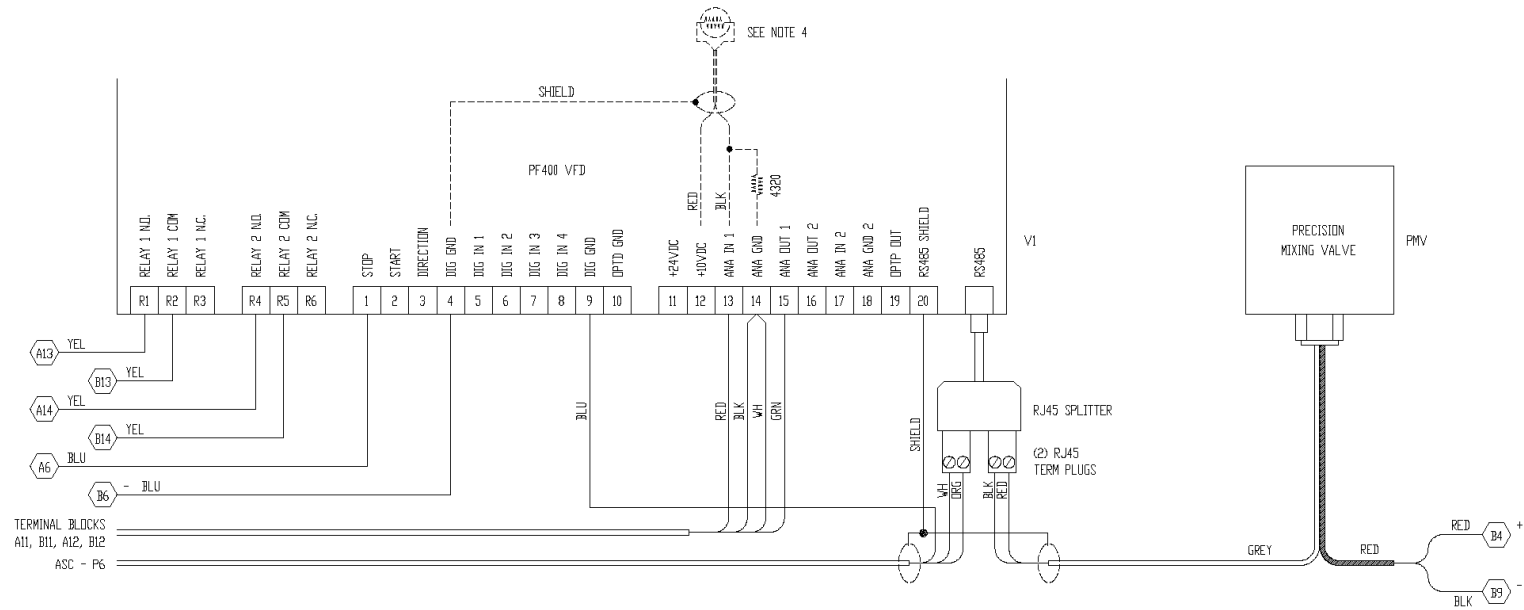

Figure 4-4 – WIRING DIAGRAM – (WATER-COOLED) 460V - Single-Stage VS Control



301CGD546-G
 (Ref. Drawing)
 Page 2 of 4



NOTES:

- SHORTING JUMPERS INSTALLED ON TERMINALS BLOCKS AS FOLLOWS
 +24VDC - B1, B2, B3, B4, B5
 DC GND - B6, B7, B8, B9, B10
 E-STOP QUALIFIED +24VDC - A5, A6
- FOR CONTROL BY REMOTE CONTACT, REMOVE JUMPER BETWEEN TERMINALS A4 AND B4 AND CONNECT N.C. SWITCH
- WHEN DRYER IS NOT INSTALLED ADVISORY/SHUTDOWN ALARM CONTACT BETWEEN A14 AND B14 CONTACT RATING: N.O., 3A @ 30VDC, 3A @ 240VAC
- WHEN DRYER THERMISTOR IS INSTALLED CONNECT RED THERMISTOR WIRE TO TERMINAL 12, CONNECT BLACK THERMISTOR WIRE TO TERMINAL 13, CONNECT 4320 OHM, 0.25W, 1% RESISTOR BETWEEN TERMINAL 13 AND TERMINAL 14.
- AUXILIARY POWER FOR MOISTURE SEPARATOR NOT INSTALLED WHEN DRYER IS USED.
- BACK PLATE MUST BE BONDED TO CONTROL BOX USING 4 AWG (MIN) BONDING STRAP.
- DOOR MUST BE BONDED TO CONTROL BOX USING 10 AWG (MIN) BONDING STRAP.
- WHEN COMMUNICATIONS MODULE IS INSTALLED AND PT3 IS INSTALLED, CONNECT PT2 TO P17, PINS 4-6.

301CGD546-G
(Ref. Drawing)
Page 3 of 4

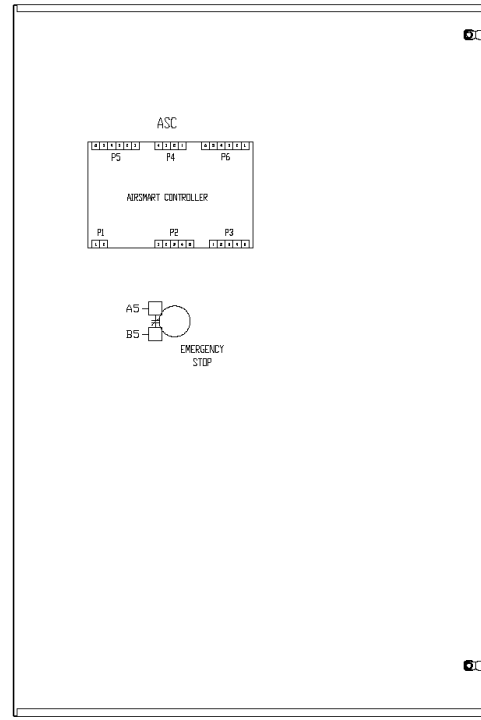
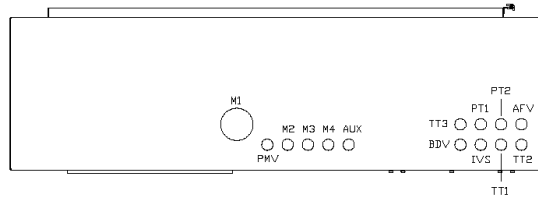
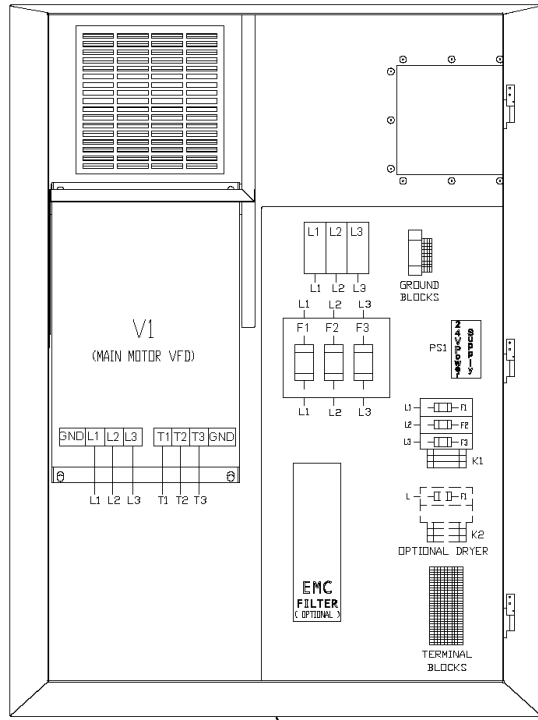
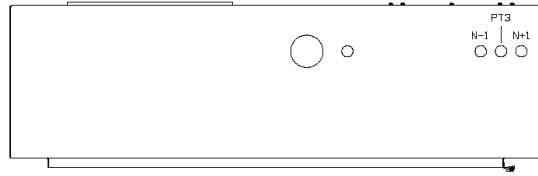

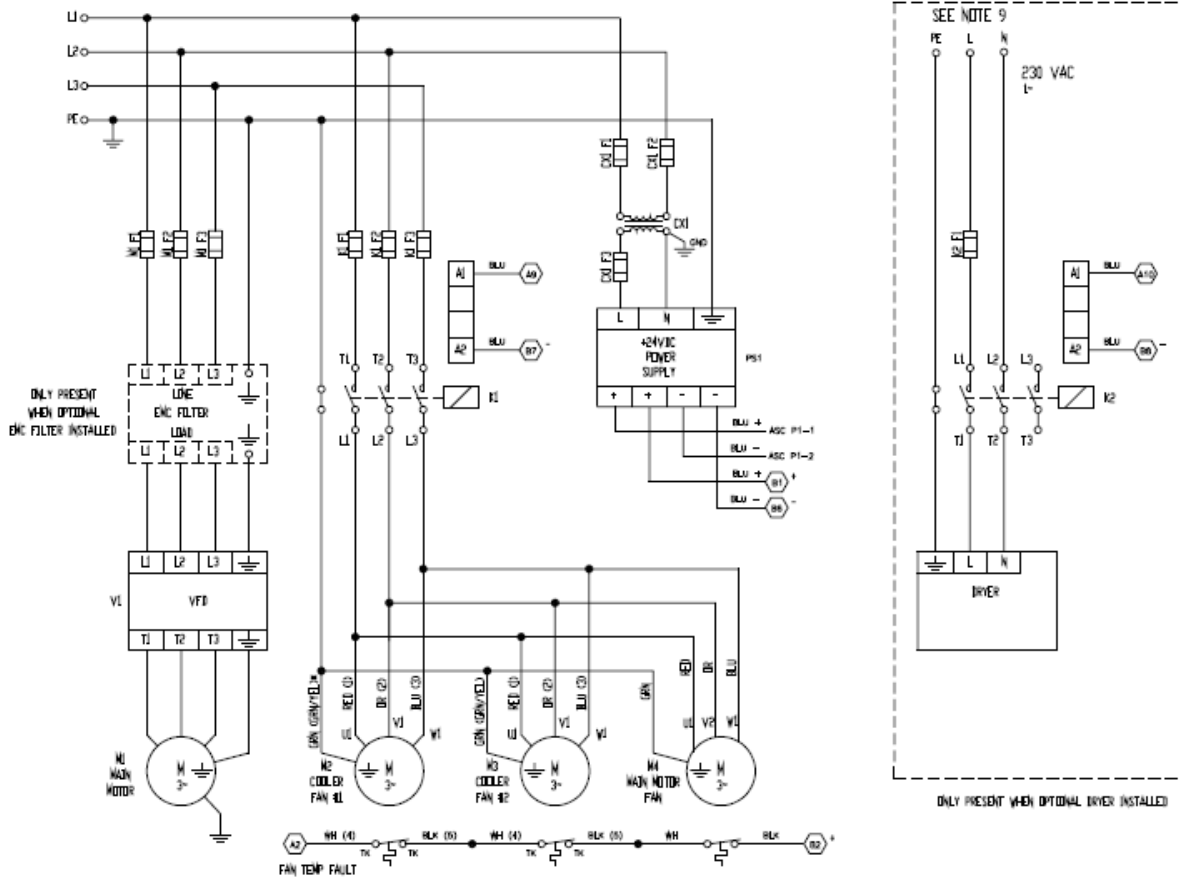

*NOTE: ALTERNATIVE CABLE MAY BE USED WITH NUMBERED BLACK LEADS AND GRN/YEL PE. WIRES FOR THIS CABLE ARE INDICATED IN PARENTHESIS ABOVE.

302CGD546-05
(Ref. Drawing)
Page 1 of 4

LEGEND

- PT1 = RESERVOIR PRESSURE TRANSDUCER
- PT2 = PLANT PRESSURE TRANSDUCER
- PT3 = SYSTEM PRESSURE TRANSDUCER
- TT1 = INLET TEMPERATURE THERMISTOR
- TT2 = DISCHARGE TEMPERATURE THERMISTOR
- TT3 = DRYER TEMPERATURE THERMISTOR
- IVS = INLET VALVE SOLENOID
- BDV = BLOW DOWN VALVE SOLENOID
- AFV = AIR FILTER VACUUM SWITCH
- ASC = AIRSMART CONTROLLER
- PMV = PRECISION MIXING VALVE
- DWD = DRYER WATER DRAIN VALVE SOLENOID
- K1 = VENT FAN CONTACTOR
- K2 = DRYER CONTACTOR
- V1 = VARIABLE FREQUENCY DRIVE
- M1 = MAIN MOTOR
- M2 = COOLER FAN #1
- M3 = COOLER FAN #2
- M4 = MAIN MOTOR FAN
- PS1 = 24V DC POWER SUPPLY
- AUX = AUXILIARY POWER FOR MOISTURE SEPARATOR
- N-1 = PREVIOUS SEQUENCED COMPRESSOR
- N+1 = NEXT SEQUENCED COMPRESSOR
- CX1 = CONTROL TRANSFORMER

Figure 4-5 – WIRING DIAGRAM – (AIR-COOLED) 575V – Single Stage VS Control

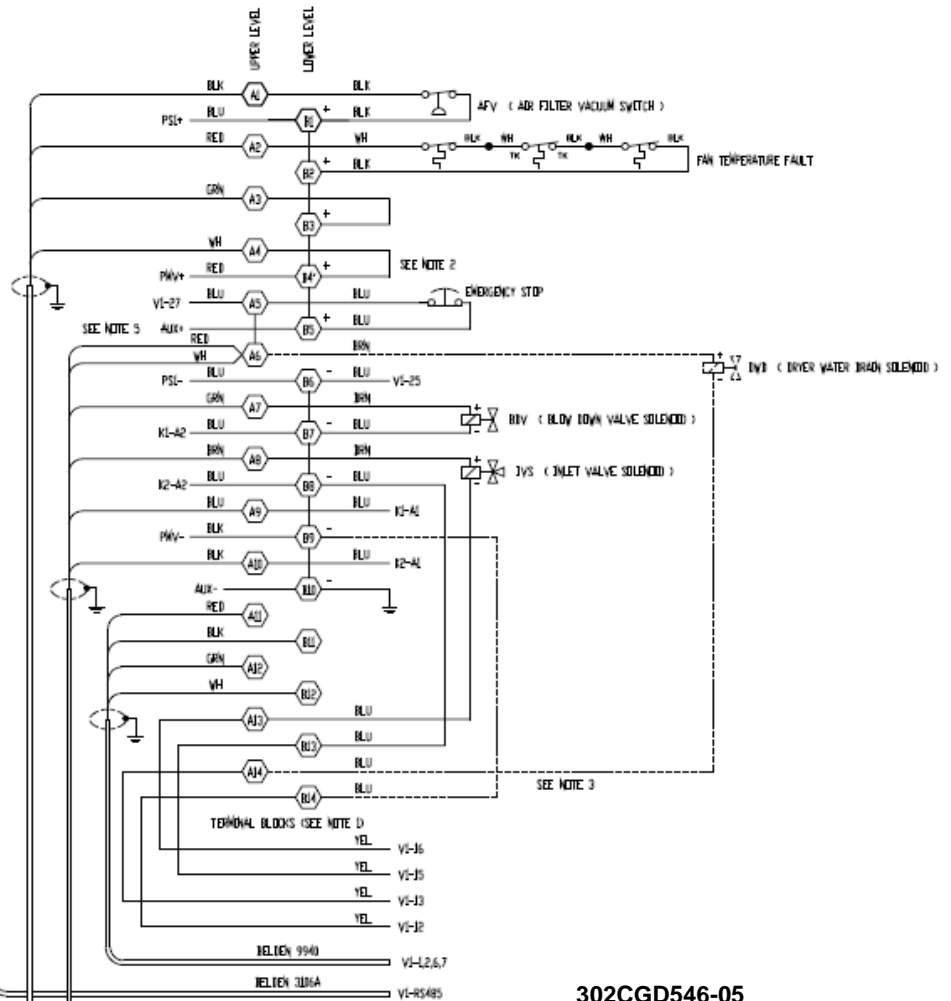
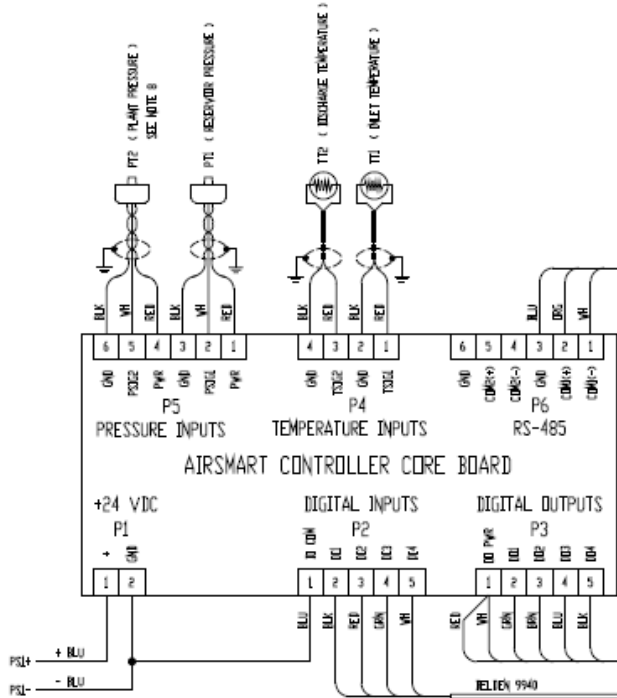
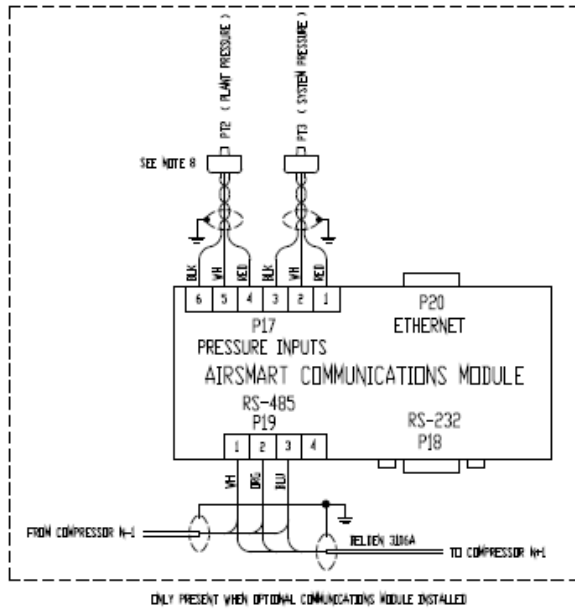

302CGD546-05
(Ref. Drawing)
Page 2 of 4

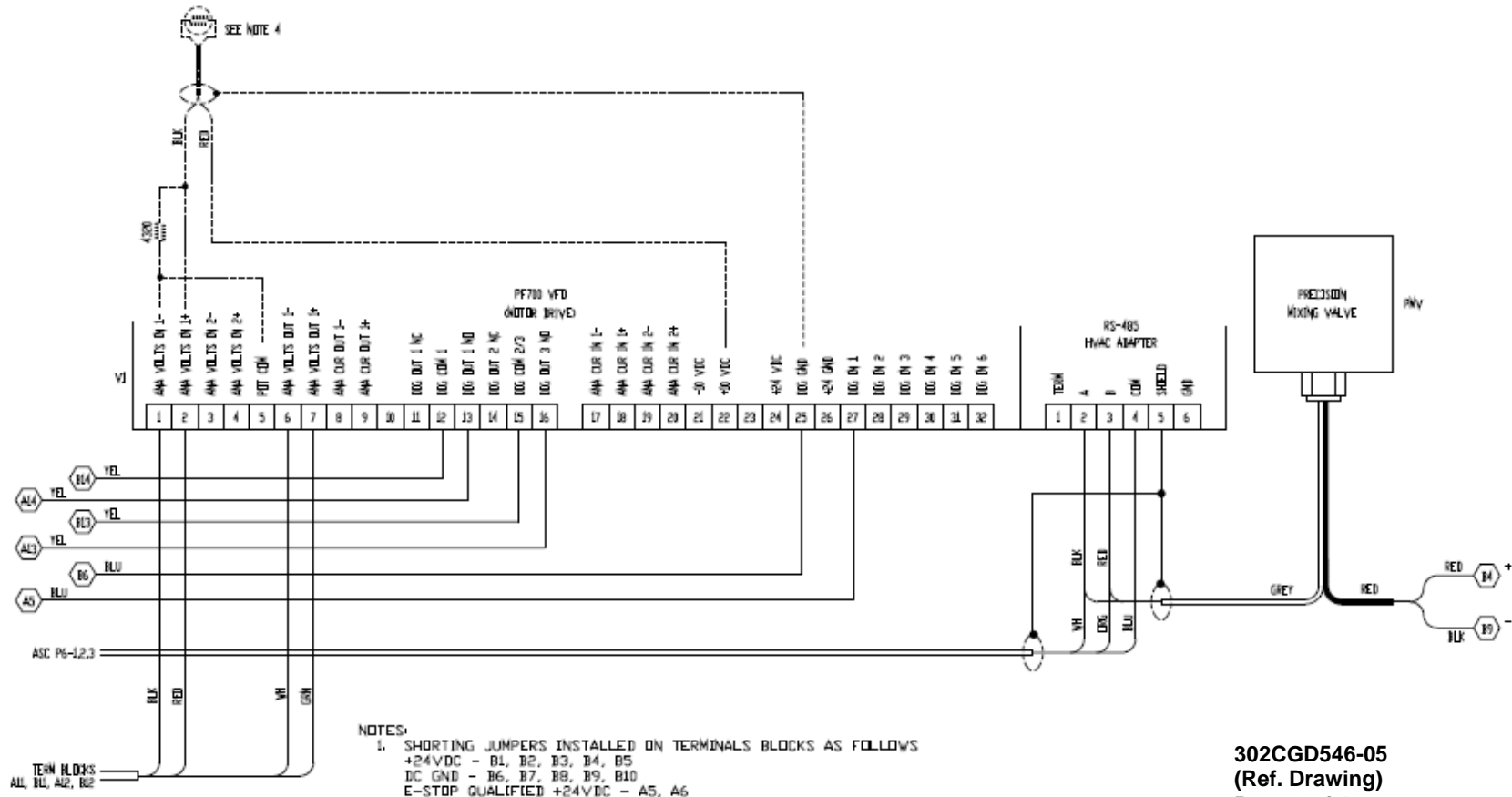

NOTES:

1. SHORTING JUMPERS INSTALLED ON TERMINALS BLOCKS AS FOLLOWS
 +24VDC - B1, B2, B3, B4, B5
 DC GND - B6, B7, B8, B9, B10
 E-STOP QUALIFIED +24VDC - A5, A6
2. FOR CONTROL BY REMOTE CONTACT, REMOVE JUMPER BETWEEN TERMINALS A4 AND B4 AND CONNECT N.C. SWITCH
3. WHEN DRYER IS NOT INSTALLED ADVISORY/SHUTDOWN ALARM CONTACT BETWEEN A14 AND B14 CONTACT RATING: N.D., 3A @ 30VDC, 3A @ 240VAC
4. WHEN DRYER THERMISTOR IS INSTALLED CONNECT RED THERMISTOR WIRE TO TERMINAL 22, CONNECT BLACK THERMISTOR WIRE TO TERMINAL 2, CONNECT 4320 OHM, 0.25W, 1/2 RESISTOR BETWEEN TERMINAL 1 AND TERMINAL 2, CONNECT WIRE BETWEEN TERMINALS 1 & 5
5. AUXILIARY POWER FOR MOISTURE SEPARATOR NOT INSTALLED WHEN DRYER IS USED.
6. JACK PLATE MUST BE BONDED TO CONTROL BOX USING 4 AWG (MIN) BONDING STRAP.
7. JODR MUST BE BONDED TO CONTROL BOX USING 10 AWG (MIN) BONDING STRAP.
8. WHEN COMMUNICATIONS MODULE IS INSTALLED AND PT3 IS INSTALLED, CONNECT PT2 TO P17, PINS 4-6.
9. SUPPLY VOLTAGE FOR OPTIONAL DRYER IS 230VAC, SINGLE PHASE (PHASE TO NEUTRAL).

302CGD546-05
 (Ref. Drawing)
 Page 3 of 4

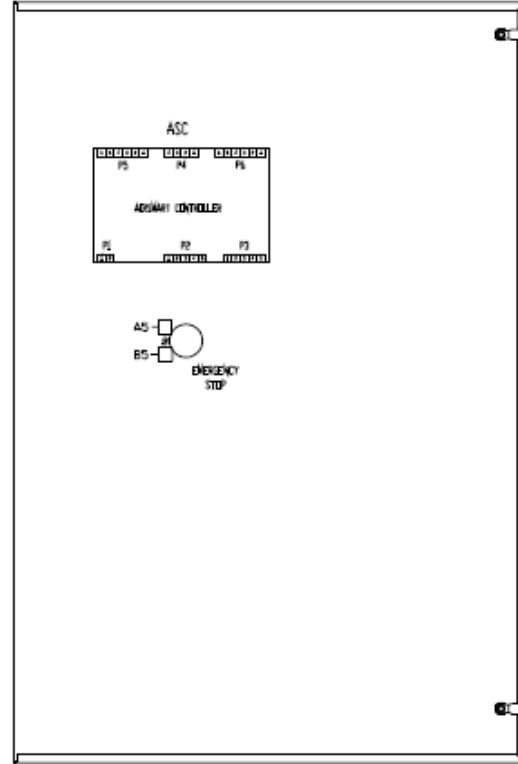
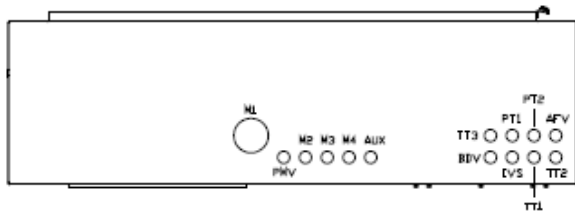
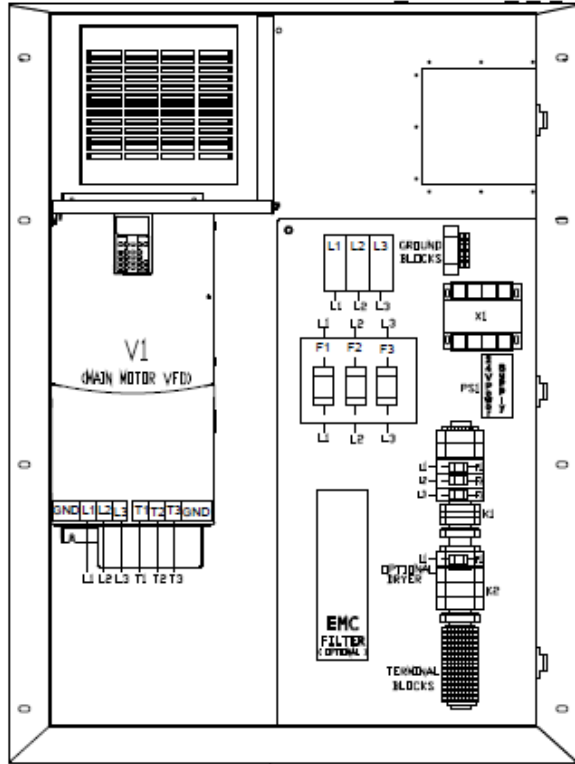

302CGD546-05
(Ref. Drawing)
Page 4 of 4

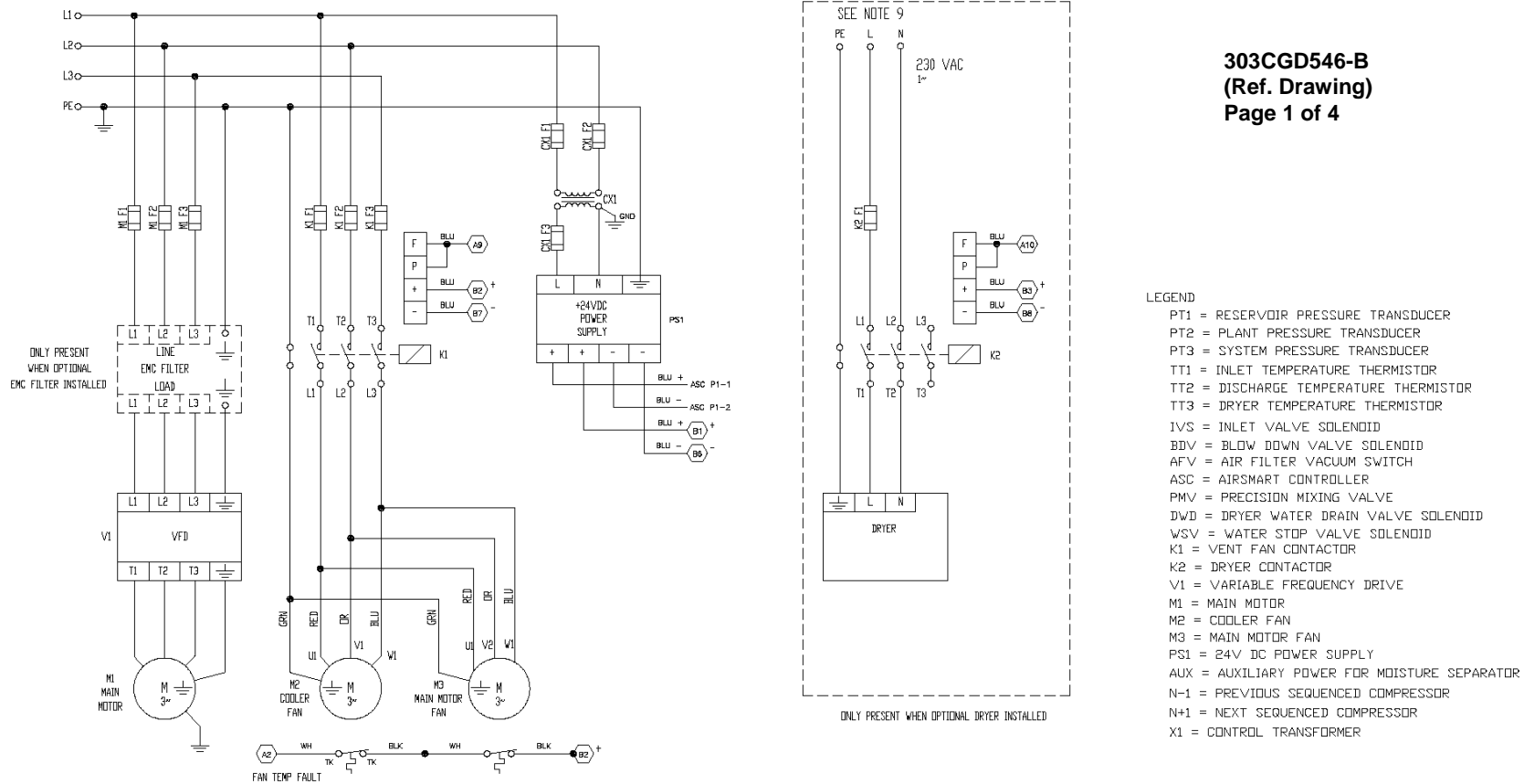
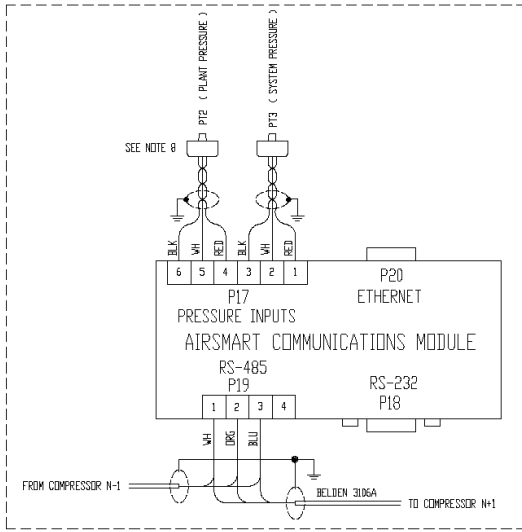
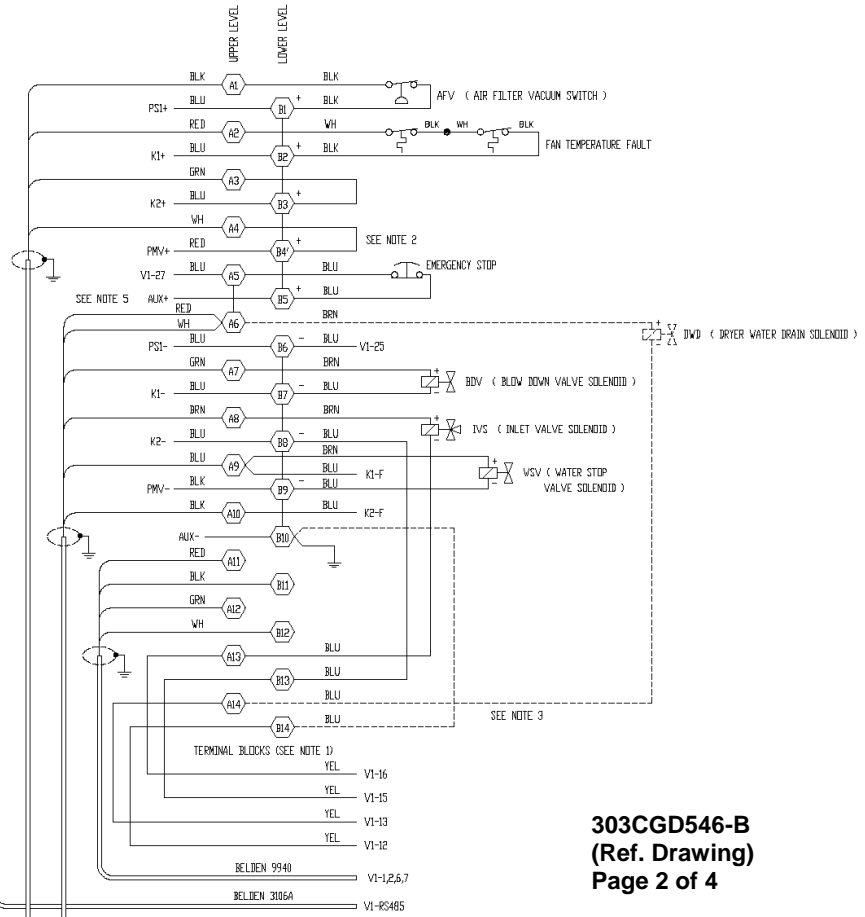
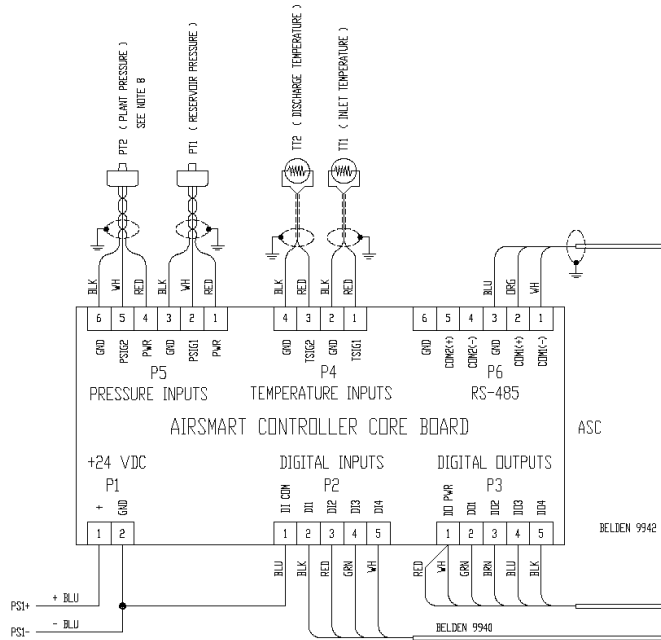

Figure 4-6 – WIRING DIAGRAM – (WATER-COOLED) 575V – Single Stage VS Control



ONLY PRESENT WHEN OPTIONAL COMMUNICATIONS MODULE INSTALLED



303CGD546-B
(Ref. Drawing)
Page 2 of 4

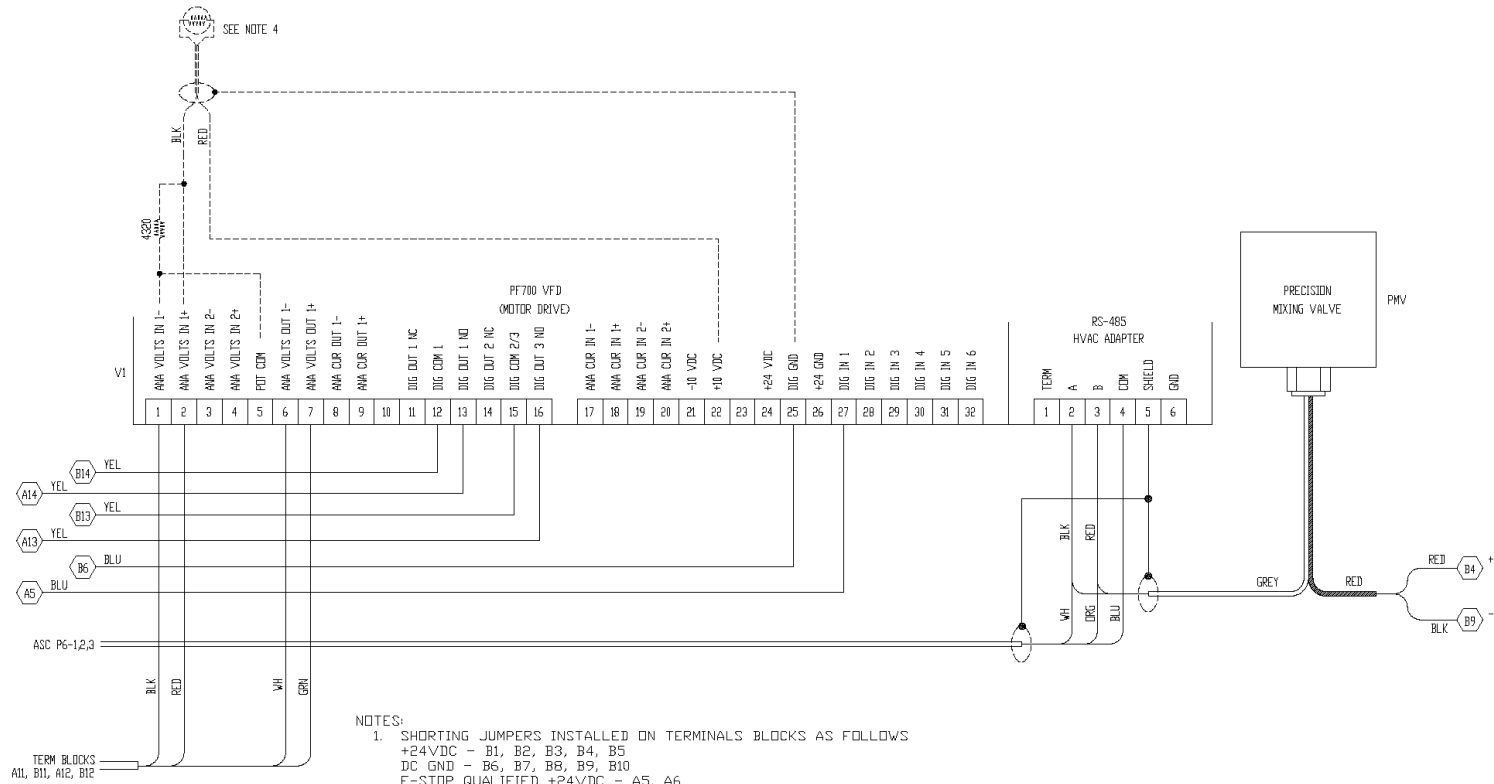

- NOTES:
1. SHORTING JUMPERS INSTALLED ON TERMINALS BLOCKS AS FOLLOWS
 +24VDC - B1, B2, B3, B4, B5
 DC GND - B6, B7, B8, B9, B10
 E-STOP QUALIFIED +24VDC - A5, A6
 2. FOR CONTROL BY REMOTE CONTACT, REMOVE JUMPER BETWEEN TERMINALS A4 AND B4 AND CONNECT N.C. SWITCH
 3. WHEN DRYER IS NOT INSTALLED ADVISORY/SHUTDOWN ALARM CONTACT BETWEEN A14 AND B14 CONTACT RATING: N.O., 3A @ 30VDC, 3A @ 240VAC
 4. WHEN DRYER THERMISTOR IS INSTALLED CONNECT RED THERMISTOR WIRE TO TERMINAL 22, CONNECT BLACK THERMISTOR WIRE TO TERMINAL 2, CONNECT 4320 OHM, 0.25W, 1% RESISTOR BETWEEN TERMINAL 1 AND TERMINAL 2, CONNECT WIRE BETWEEN TERMINALS 1 & 5
 5. AUXILIARY POWER FOR MOISTURE SEPARATOR NOT INSTALLED WHEN DRYER IS USED.
 6. BACK PLATE MUST BE BONDED TO CONTROL BOX USING 4 AWG (MIN) BONDING STRAP.
 7. DOOR MUST BE BONDED TO CONTROL BOX USING 10 AWG (MIN) BONDING STRAP.
 8. WHEN COMMUNICATIONS MODULE IS INSTALLED AND PT3 IS INSTALLED, CONNECT PT2 TO P17, PINS 4-6.
 9. SUPPLY VOLTAGE FOR OPTIONAL DRYER IS 230VAC, SINGLE PHASE (PHASE TO NEUTRAL).

303CGD546-B
 (Ref. Drawing)
 Page 3 of 4

SECTION 5

COMPRESSOR LUBRICATION – SEPARATION, FILTRATION AND CONTROLS



Air/oil under pressure will cause severe personal injury or death. Shut down compressor, relieve system of all pressure, disconnect, lockout and tagout power supply to the compressor package before removing valves, caps, plugs, fittings, bolts and filters.

CAUTION

High temperature operation can cause damage to equipment or personal injury. Do not restart the unit repeatedly after high temperature shutdown. Find and correct the malfunction before resuming operation.

COMPRESSOR OIL SYSTEM – Lubricating oil is employed to absorb the heat of compression, lubricate moving parts and seal internal clearances between the rotor and air cylinder. Pressure differential between the air/oil reservoir and various injection points is used to flow oil through the package.

Oil exits the air/oil sump and is then routed to the heat exchanger and the thermal mixing valve, where cold (oil cooler branch) and hot (bypass branch) are mixed to a temperature that will avoid water vapor condensation within the oil system. Tempered oil is sent to the oil filter for cleaning, then onto injection. The injected oil absorbs heat from compression while progressing through the compression chamber and is then discharged back into the oil separation chamber as a mixture of liquids and aerosols (oil) and gas (air).

Centrifugal action within the air/oil reservoir separates the bulk of the oil from the air, where it is collected and readied for the next cooling cycle. The compressed air and aerosols continue through a coalescing filter, where all but 2 to 4 ppm of oil is removed from the compressed air and discharged to the aftercooler.

RECOMMENDED LUBRICANT – The Gardner Denver compressor is factory-filled with AEON 9000SP lubricant. This lubricant is formulated to the highest quality standards and is factory-authorized, tested and approved for use in our rotary screw compressors. AEON 9000SP lubricant is available through your authorized Gardner Denver compressor distributor.

OIL SPECIFICATIONS - The factory fill compressor lubricant is Gardner Denver AEON 9000SP lubricating coolant for all-year-round operation. This is a polyalphaolefin (PAO) synthetic lubricant specially formulated for rotary screw compressor service.

It is highly recommended that the lubricating oil be analyzed frequently in order to identify its quality and remaining operational life. A sampling valve, located on the heat exchanger manifold is provided for this purpose.



Use of improper lubricants will cause damage to equipment. Do not mix different types of lubricants or use inferior lubricants.



All materials used in Gardner Denver compressor units are compatible with AEON 9000SP Synthetic Lubricating Coolant. Use caution when selecting downstream components such as lubricating bowls, gaskets and valve trim.

AEON 9000SP Synthetic Lubricating Coolant is not compatible with Nitrile (Buna N) or acrylic paints. AEON 9000SP is compatible with most air system downstream components.

Material Safety Data Sheets (MSDS) are available for all AEON lubricants at:
www.gardnerdenverproducts.com/downloads.aspx

MOISTURE IN THE OIL SYSTEM - The oil mixing valve provided with your compressor package has been designed to avoid water vapor condensation during all modes of operation (e.g., load level, ambient temperature or relative humidity and discharge pressure). See "Oil Mixing Valve" notes within this section for further details on this device.

This feature does not eliminate the need to analyze the lubricating oil frequently. If an analysis reveals the presence of water in the oil, it may indicate that the oil mixing valve is malfunctioning. Contact your authorized Gardner Denver factory distributor for assistance.

OIL SITE GLASS - This device indicates oil level within the air/oil reservoir. Check oil level only with the compressor stopped. Normal oil level is the white-colored, middle portion of the measuring rod. Add oil only when oil level has reached the red-colored, bottom portion of the measuring rod. Drain oil only when the oil level is beyond the top of the measuring rod.

ADDITION OF OIL BETWEEN CHANGES – Oil losses (typically 4 ppm) from the oil separation system may require replenishment between scheduled changes. If (during operation only) the site glass shows no oil or less than 25% of full height, add oil per following steps: (See Figure 5-1, page 49).

1. Be sure the unit is completely off and oil sump is depressurized.
2. Disconnect lockout and tagout the power supply to the compressor package.
3. Close (when provided) valve isolating compressor package from air system.
4. Wipe away all dirt around the oil filler plug.
5. Remove the oil filler plug (1) and add (or drain by opening valve (3) if correcting high level) sufficient oil to adjust its level to nearly the top white-colored, middle portion of the measuring rod.
6. Install the oil filler plug, open isolation valve (when provided), restore power, then run unit to check for leaks.

Note that repeated addition of oil between oil changes may indicate excessive oil carry-over and should be investigated.



Excessive oil carry-over can damage equipment. Never fill oil reservoir above the upper red-colored portion of the measuring rod



Use only CLEAN containers and funnels to avoid contamination of oil. Provide for clean storage of oils. Changing the oil will be of little benefit if done in a careless manner

OIL CHANGE INTERVAL – The AEON 9000SP Synthetic Lubricating Coolant shall be changed every 8000 hours of operation or as prescribed by the results of an oil analysis, whichever comes first. Note that severe operating conditions (e.g., very dusty, high humidity, etc.), may require more frequent oil changes.

Gardner Denver offers a free oil analysis program with our AEON 9000SP lubricant. The first sample from a new unit should be sent in between 40-100 hours of operation.

DRAINING AND CLEANING OIL SYSTEM - Always drain the complete system. Draining when the oil is hot will help to prevent varnish deposits and carry away impurities. To drain the system, use the following method: (See Figure 5-1, page 49).

1. Be sure the unit is completely off and oil sump is depressurized.
2. Disconnect lockout and tagout the power supply to the compressor package.
3. Close (if provided by user) valve isolating compressor package from air system.
4. Remove fill plug (1) and drain valve (3) to evacuate oil.
5. Close drain valve (3), add oil up to top of the white-colored, middle portion of the measuring rod, and replace fill plug.
6. If the drained oil and/or the oil filter element are contaminated with dirt, flush the entire system, reservoir, oil cooler, mixing valve and lines. Inspect the oil separator element for dirt accumulation; replace if necessary. If a varnish deposit exists, contact the factory for recommendations for removal of the deposit and prevention of varnish.

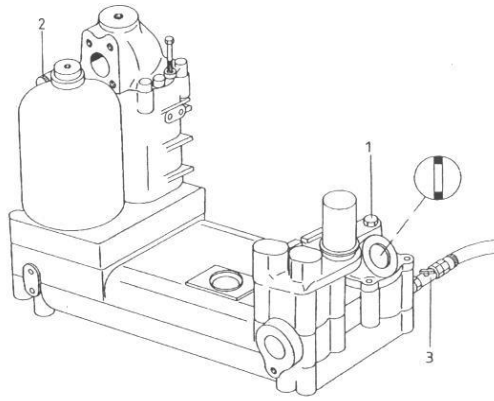

Figure 5-1 – CHECKING OIL LEVEL

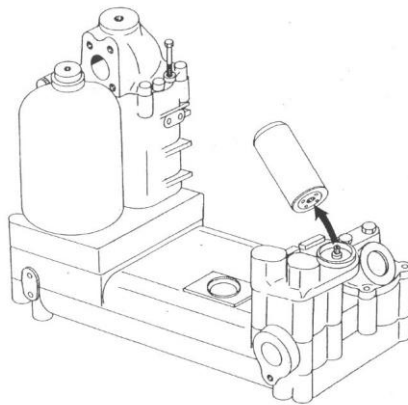

Figure 5-2 – CHANGING OIL FILTER

REFILLING OIL SYSTEM - The steps to refill the drained oil system are the same as those already presented for the addition of oil between changes – see page 47, for full details. The only exception is that to fill all the empty lines and components (e.g., oil cooler, compressors, and oil filter) a much larger volume of oil will be required.

The VS45-70 package requires nearly 6 gallons of AEON 9000SP Synthetic Lubricating Coolant to fill all the lines and components and achieve normal oil level.

COMPRESSOR OIL FILTER - The oil filter is a vital part in maintaining a trouble-free compressor, since it removes dirt and abrasives from the circulated oil. It should be replaced every 1000 hours of operation, sooner if necessary due to dirty environment and when the oil is changed.

A flow bypass valve, mounted inside the filter cartridge, provides uninterrupted oil flow when the filter element is contaminated and its backpressure exceeds 29-36 psid (at typical operating conditions of 140°F and 100 psi). However, since this condition introduces unfiltered, potentially contaminated oil into the compressor, it is best avoided by following the recommended filter replacement intervals.

CAUTION

Improper oil filter maintenance will cause damage to equipment. Replace filter element every 1000 hours of operation. More frequent replacement could be required depending on operating conditions. A filter element left in service too long may damage equipment.

The filter media is contained within an easily replaced, spin-on cartridge. Use the following procedure to replace the filter. Do not disturb the piping:

1. Be sure the unit is completely off and that the oil sump is depressurized.
2. Disconnect lockout and tagout the power supply to the compressor package.
3. Close (when provided) valve isolating compressor package from air system.
4. Unscrew the cartridge with adequate tool (e.g., strap wrench) and remove.
5. Clean (wipe) and lubricate sealing surface on filter housing with grease.
6. Lubricate o-ring seal on new element with grease.
7. Screw-new element onto filter head firmly – approximately 3/4 turns after cartridge and head make contact.
8. Open isolation valve (when provided), restore power, then run unit to check for leaks.

OIL MIXING VALVE (Electronic) – This device mixes cold (from oil cooler) and hot (bypassed) oil in order to achieve a compressor discharge temperature above the saturation level of the water vapor contained in the compressed air – thus avoiding water collection in the oil system.



Figure 5-3 – THERMOSTATIC MIXING VALVE ELEMENT

Normal Package Operation - **The AirSmart controller includes an algorithm that determines, in real time, and on the basis of the intake temperature and the programmed target discharge pressure, the minimum discharge temperature the compressor must attain in order to keep water vapor from condensing in the oil system. Signals from the controller command the 3-way ball valve servo to rotate and mix hot and cold oil streams until the desired compressor discharge temperature is achieved. Refer to**

Figure 5-4 for the dew point trends of the compressed air at four typical pressure levels.

At startup, the mixing valve is on full bypass mode. As system heat load increases with ambient temperature or load, the mixing valve sends more oil flow to the cooler to maintain adequate compressor discharge temperature.

While the mixing valve is in its modulating range (between extremes of valve position), a compressor discharge temperature deviation exceeding +/- 10°F from the calculated value will trigger an alarm display to caution that a system malfunction is taking place. Note that the alarm is not triggered once the valve has reached either end-of-travel position, as oil mixing no longer controls the compressor discharge temperature.

Low Air Demand and Package Operation – During periods of very low air demand, such as when the package is operated in short cycles, the oil system may not reach a high enough temperature to keep water vapor from condensing, in spite of the oil mixing valve bypassing all flow around the heat exchanger.

Under these conditions, it is recommended that the package operation be prolonged after each unload condition is achieved - this can be easily accomplished by adjusting the “Auto Timer” option in the AirSmart controller. Refer to the AirSmart controller user’s manual 13-17-600 for detailed programming instructions of this parameter and adjust the “Auto Timer” parameter to a value of at least 5 minutes.

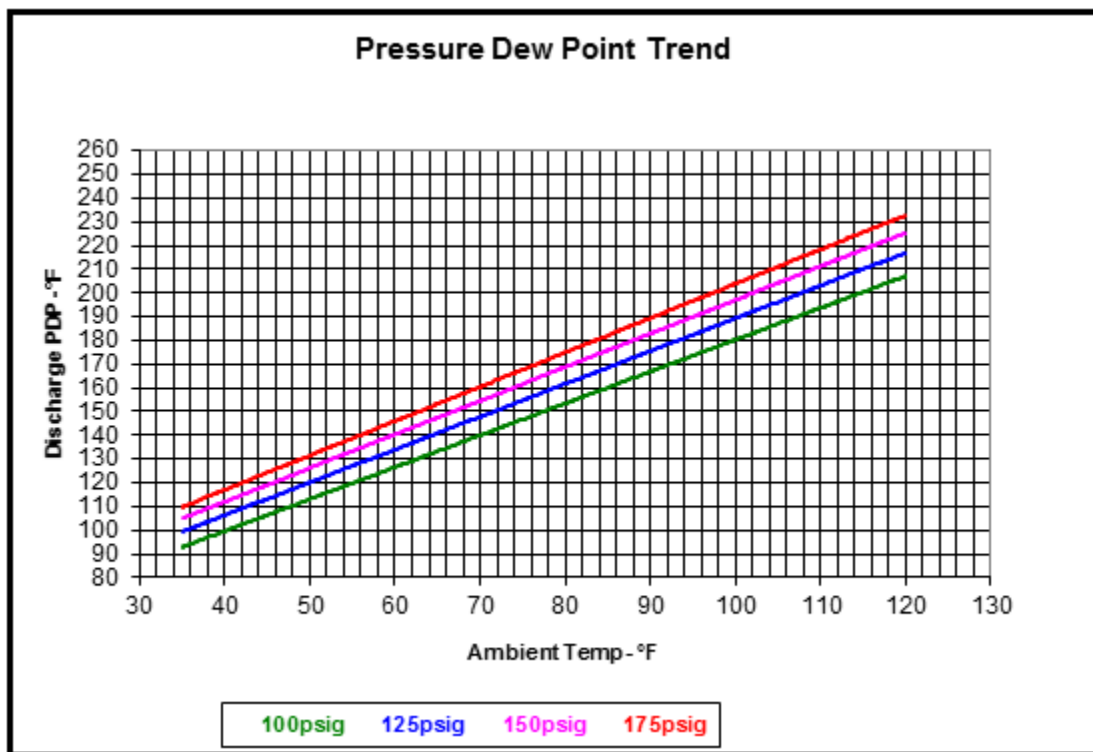

Figure 5-4 – PRESSURE DEW POINT OF COMPRESSED AIR

OIL SEPARATION RESERVOIR / COALESCING ELEMENT - This device serves multiple functions in the compressor package:

- **Air/oil centrifugal separation** - The bulk of the liquid oil is separated, by change of direction, impingement and additional centrifugal effects, away from the compressed air and aerosol streams, and is then gravity-collected at the bottom of the sump.
- **Oil degassing and holding** - The sump has sufficient holding capacity to degas the oil mass before it is drained off on its way to cooling, filtering and re-injection. It also serves as a storage volume for the oil mass migrating from higher elevations (e.g., oil cooler, compressor casings, and piping).
- **Air/oil final separation** - The aerosols and compressed air streams are led to the upper portion of the sump, where the coalescing element resides. The fine droplets of oil (aerosol) are trapped in the element media, coalesced, then gravity-drained, through a low-point connection and associated tubing (oil return line) into a lower pressure region of the compressor.

Separation performance - The package oil separation system has been designed to yield 2 ppm total oil carryover at the discharge of the air/oil reservoir – the oil content level at the discharge of the package will be lower and will depend on the amount of moisture rejected by the aftercooler.

This high level of performance will be affected by the following typical offset conditions:

- Contaminated (e.g., dirt, varnish, moisture) or damaged (e.g., ruptured) coalescing element.
- Contaminated (e.g., dirt, varnish, moisture) or inadequate oil in use.
- High oil level in air/oil reservoir.
- Blockage of oil return line strainer or orifice.
- Abnormally frequent or fast depressurization cycles - leading to oil foaming.

Oil separator element life cannot be predicted; it will vary greatly depending on the conditions of operation, the quality of the oil used and the maintenance of the oil and air filters. The condition of the separator can be determined by pressure differential gauging or by inspection.

Oil Coalescing Element Monitoring - The AirSmart controller keeps track of the pressure differential across the coalescing element. A pressure differential of 8 psi will trigger a service advisory to change the element and a pressure differential of 15 psi will initiate a system shutdown.



Using an oil separator element at excessive pressure differential can cause damage to equipment. Replace the separator when the "Change Separator" advisory appears.

NOTICE

A sudden drop to zero pressure differential or sudden heavy oil carryover may indicate a ruptured element.

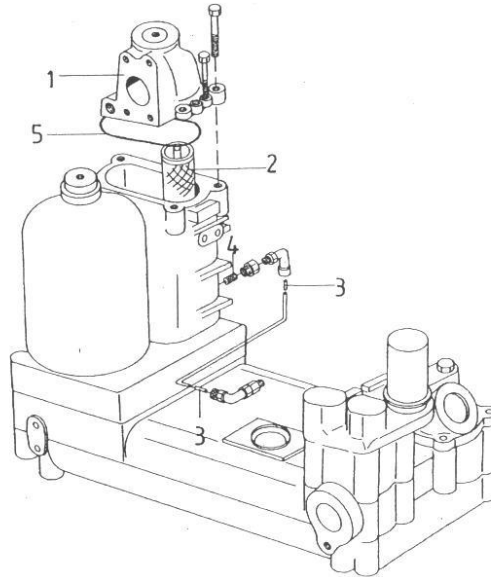

Figure 5-5 – CHANGING OIL COALESCING ELEMENT

Oil Coalescing Element Service – Use the following procedures to replace or inspect the element:

1. Be sure the unit is completely off and that oil sump is depressurized.
2. Disconnect, lockout and tagout power supply to the compressor package.
3. Remove body of MPV/sump cover (1).
4. Lift the elements (2) from sump.
5. Inspect and/or replace the elements if necessary - shine a light inside each element to reveal areas of heavy dirt, varnish deposits or breaks (ruptures) in its media. Also inspect (sealing) o-ring in elements for damage. Before installing new or old element, apply (heavy) grease to sealing o-ring. Oil may be wiped off by the holder and the o-ring could be damaged.
6. Inspect oil scavenge orifice (3) and strainer (4) for fouling. Replace if necessary.
7. Wipe the MPV/sump cover seal o-ring (5) clean and inspect for damage. Replace if necessary.
8. Lower elements into sump and press element down into respective holder. Do not use excessive force as element damage may occur.
9. Carefully place MPV/sump cover and o-ring seal on sump flange. Check that centering pins (on MPV/sump cover) have engaged each element cavity and that MPV/sump cover lays flat against sump flange. Install and tighten all cap screws.
10. After compressor is started and pressurized, inspect MPV/sump cover joint for leaks.

SECTION 6 HEAT EXCHANGERS (OIL, AIR)



Compressor, air/oil reservoir, separator chamber and all piping and tubing may be at high temperature during and after operation.



Do not attempt inspection or cleaning of air-cooled heat exchangers until cooling fan has stopped rotating. Disconnect, lockout and tagout package from power supply.



Automatic restarting or electrical shock can cause injury or death. Disconnect, lockout and tagout package from the power supply.

OIL/AIR HEAT EXCHANGERS – The heat of compression absorbed by the oil injected into the compressors (for cooling and lubrication) is ultimately rejected in a convenient medium such as air (for air-cooled cores) or water (for water-cooled cores). Proper operation of these heat exchangers is essential for the following processes:

- The compressors require a stable, cool (140°F typical at 80°F ambient air) supply of injection oil in order to operate at optimal efficiency. Under these conditions, the oil core allows 23gpm oil flow with 7.7psid pressure loss.
- The lubricating and cooling oil must be kept at a normal operating temperature below 225°F in order to preserve its longevity.

- The compressed air supply must be delivered into the distribution system at a temperature not exceeding 15°F above the ambient level in order to protect other devices (e.g., filters, dryers, tools, etc) against damage. At 100 psi of discharge pressure, the air core allows the flow of 427 cfm with 1.1 psid pressure loss.

AIR-COOLED HEAT EXCHANGERS – Air-cooled cores (radiator-type) are provided as standard feature. Axial fans (one on VS45, two on VS50 and VS70), located below the heat exchangers, pump the required amount of cooling air and expel it through an opening on the enclosure roof. Each fan is driven by a close-coupled, IP54-protected, electric motor. A common full-voltage starter energizes the fan motors.

Refer to Figure 6-1 for estimates of ventilation requirements. Please note that the air-cooled package requires the combined total of the heat exchanger plus the enclosure ventilation flow rates (which include motor ventilation and compressor intake). Furthermore, when package location makes it necessary to duct fresh cooling air in/out, these ducts must be sized with a maximum (total) pressure loss of .1 inch water gauge to avoid impacting the heat exchanger cooling air system. An external ventilation fan may be required to properly evacuate hot air from the compressor room.

Minimum Cooling Air Flow Requirements		
CFM		
KW	Air-Cooled Heat Exchangers	Enclosure Ventilation Fan
45	5200	1600
50	8223	1600
70	8223	1600

Figure 6-1 – AIR FLOW CHART

All the required hardware, mechanical and electrical connections have been made at the Gardner Denver factory, thus the only regular maintenance required is to keep the exterior core fins free from dirt and other airborne debris per the following procedure:



Air-cooled heat exchanger cores are fabricated from aluminum. Do not use caustic liquids to cleanse core or permanent damage will take place.

1. Be sure the unit is completely off and that oil reservoir is depressurized.
2. Disconnect, lockout and tagout power supply to the compressor package.
3. Open and/or remove enclosure door panels adjacent to cooler assembly.
4. Locate cooler housing side covers (See Figure 6-2) and remove by unscrewing fasteners.
5. Inspect core area. If blocked with debris, use a moderate (e.g., 100psi) source of compressed air and/or water while directing nozzle (pointed through core to inside) to dislodge debris and clean. Vacuum (applied from inside) can also be employed to clean the heat exchanger cores.

6. Remove all loose debris and water from cooler box after cleaning process is complete.
7. Re-attach cooler housing side covers with provided fasteners and re-install enclosure door panels.

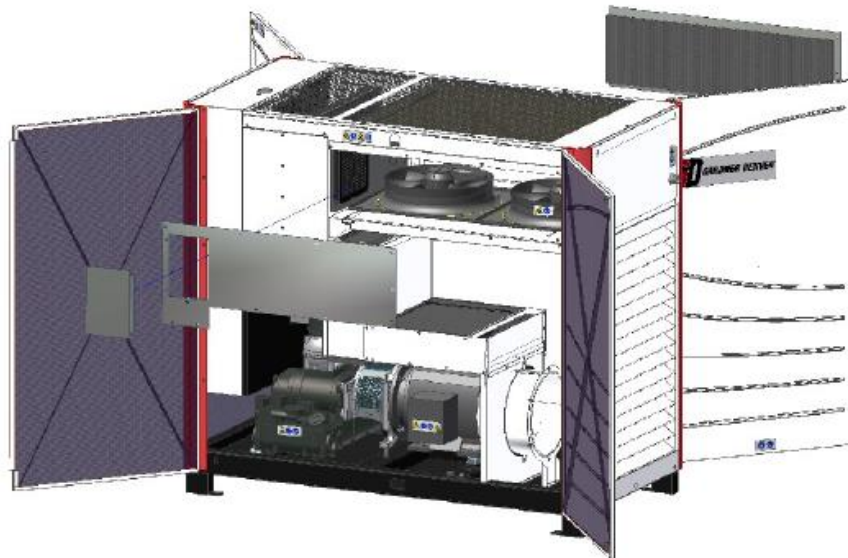

Figure 6-2 – COOLER HOUSING SIDE COVERS



Automatic restarting or electrical shock can cause injury or death. Disconnect, lockout and tagout package from the power supply.

AXIAL COOLING FANS

1. Follow the Lock-Out Tag-Out procedures to de-energize the package. Allow adequate time for the VFD capacitors to fully discharge before beginning maintenance.
2. Exercise caution around compressor parts after stopping the package for service. Fans and coolers will be hot after stopping the compressor.
3. Remove access panels and guards as needed to gain access to the fan blades.
4. Cover motors, mixing valves, fan motors and other electrical components to prevent damage from the cleaning process.
5. Use a mild detergent or degreaser to soften and dissolve accumulated grime.
6. Using a soft cloth or sponge, remove the surface grime from both sides of the blade surface.
7. Wipe up and remove all traces of cleaning residue and cleaning materials.
8. Reinstall all access panels and guards that were removed to access the fans.
9. Follow the Lock-Out Tag-Out procedures to re-energize the package.
10. Jog fans to verify there is no interference with the guard or cowling ring before the package is placed back in service.

All axial cooling fans should be inspected and cleaned at the same interval as the heat exchangers are. Ambient conditions will determine the actual maintenance interval at each installation.

WATER-COOLED HEAT EXCHANGERS – Optional water-cooled cores (brazed-plate type) are available. Both cores are of a counter-current and cross-flow design. The cooling water is fed to the cores in a series arrangement – it passes through the air core first and proceeds through the oil core before exiting the package. Please refer to Figure 6-3 for estimates of requirements.

AIR & OIL COOLER (Series Water Piping)							
		Water flow requirements at various inlet water temperatures (gpm)				Maximum Water Flow (gpm) *	Approximate (total) water pressure drop @ 90° F water flow (psi)
KW	Model	60° F	70° F	80° F	90° F		
All	VS45-70C	14.4	18.4	25.6	40	40	20

* Flows exceeding "Maximum Water Flow" will cause severe erosion and will void unit warranty.

Figure 6-3 – WATER-COOLED HEAT EXCHANGER COOLANT REQUIREMENTS

The water supply shall be capable of delivering the flow/temperature combinations shown in Figure 6-3, page 57, at a minimum pressure of 40 psig (2.8 bar) - the water flow rates shown are approximate and a guide to sizing of piping, cooling tower and other water system equipment.

The maximum allowable supply water pressure is 150 psig (10.3 bar) and the maximum allowed (package) outlet water temperature is 110°F (43°C). If a water supply with a temperature lower than 60°F (16°C) is used, heat transfer areas of the coolers may be fouled due to low water flow velocities, resulting in poor cooler performance and shortened operational life.

All the required hardware, mechanical and electrical connections have been made at the Gardner Denver factory. Regular maintenance is required to keep the interior core areas free from dirt and other fouling agents. In order to protect package components that are in contact with the cooling water from attack by corrosive or fouling agents, we recommend that the cooling water meet the following quality standards:

Total Dissolved Solids (TDS).....	<500 ppm
Iron.....	<2 ppm
Total Hardness	<60 ppm
Silica	<25 ppm
Oil and Grease.....	<5 ppm
Sulfate.....	<50 ppm
Chloride.....	<50 ppm
Nitrate	<2 ppm
Corrosivity.....	Langelier Index between 0 to 1

It is strongly recommended that a reputable, local firm be contracted to evaluate the quality of water available and recommend corrective and/or preventive steps to meet our requirements.

WATER FLOW REGULATING VALVE (Optional Hardware). This device is used to adjust the flow of cooling water in proportion to its temperature. It's a normally closed (two-way) valve which opens once the thermostatic bulb senses a predetermined water temperature level and then continues to modulate water flow to maintain water temperature – within a 2° F to 5° F span. The package piping provides a permanent bypass line (1/4" tube) around the flow regulating valve to ensure a small amount of water flows around the sensing bulb when the valve is in the closed position – it does not provide a complete shutoff of water flow.

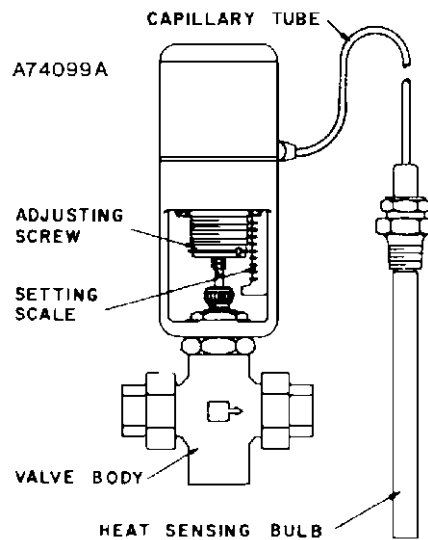

Figure 6-4 – WATER CONTROL VALVE

Adjustments – The regulator valve shall be adjusted so that it closes when the cooling water entering and exiting the package are at the same temperature – a condition that is present after the compressors have stopped and the heat exchangers have cooled down. Note that the bypass line allows a small amount of water flow when the valve closes. Adjustment to the regulator valve can be made as follows:

- To decrease water flow (e.g., increase exiting cooling water temperature) turn the adjusting screw from left to right, increasing spring tension. (The groove at the lower edge of the adjusting screw is an index line for use with the index scale 0 to 8 in obtaining a desired setting).
- To increase water flow (e.g., decrease exiting cooling water temperature) turn the adjusting screw from right to left, decreasing spring tension. (The groove at the lower edge of the adjusting screw is an index line for use with the index scale 0 to 8 in obtaining a desired setting).

Care must be used when handling the capillary tube; a kink or break in the tubing or connections will make the valve inoperative. Never attempt to change capillary length. Excess capillary tube should be carefully coiled and placed so that damage will not occur with normal maintenance or traffic past the unit.

If a leak develops through the packing, tighten the packing gland nut firmly with a wrench to reseal the packing around the valve stem, back off the nut until loose and finally retighten the nut finger tight. Tightening the packing nut too tight may cause erratic operation. An occasional drop of oil on the valve stem at the packing nut will prolong packing life.

If the valve malfunctions, check for a bend or binding in the capillary tube, paint or corrosion on valve stem, foreign material in valve, erosion or thermal system (capillary) failure.

WATER FLOW SHUTOFF VALVE (Optional Hardware) - This device completely shuts off the flow of cooling water when the compressors are not operating. Its normally closed state prevents the waste of cooling water even in the case of power failure. It is a common companion to the water flow regulating valve.

The water flow regulating valve and the water shutoff valve are factory-installed options. If the presence of foreign material or scale formation in the cooling water is likely, the use of a strainer in the inlet water line is recommended.

OPTIONAL WATER SEPARATOR AND DRAIN – These devices separate and drain the water (condensed by the air cooler) mixed with the compressed air delivered by the compressor package. The optional water separator assembly is shipped loose and must be field-installed by the end user. Note that this device is not used if the optional compressed air dryer is supplied, as the latter's water separator is employed for this process.

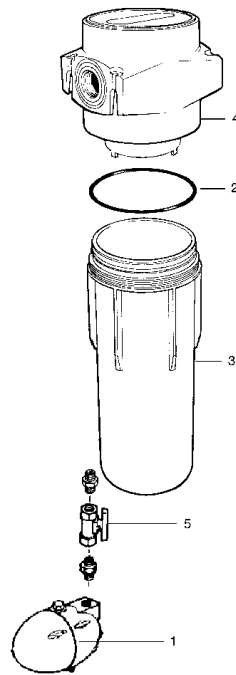

Figure 6-5 – WATER SEPARATOR AND DRAIN

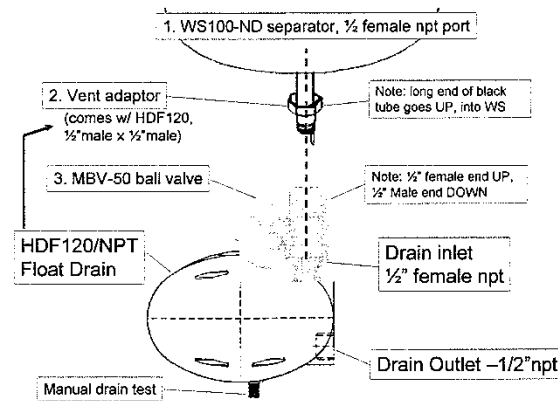

Figure 6-6 – WATER SEPARATOR AND DRAIN DETAILS

The separator (4) removes the liquid water from the compressed air stream by inertial effects and collected in a lower bowl (3). The collected water is evacuated by a float-type drain valve (1). The device prevents the loss of compressed air by only allowing the discharge of liquid water during its opening phase. An isolation ball valve (5) is provided between the separator bowl (3) and the drain valve body (1). This allows the safe and quick removal of the drain valve for servicing, in case the drain valve malfunctions.

In case the drain valve is fouled with dirt, cleanse the collection bowl also:

1. Be sure the unit is completely off and oil sump is depressurized.
2. Disconnect, lockout and tagout power supply to the compressor package.
3. Close (when provided) valve isolating compressor package from air system.
4. Unscrew drain valve (1) from isolation valve (5).
5. Unscrew collection bowl (3) from separator housing (4).
6. Inspect and clean collection bowl and sealing o-ring.
7. Reinstall in reverse order. If the vent adaptor has been removed from the bowl, note its location and orientation in relation to the bowl (5) – see detail Figure 6-6. The long end of the black tube attached to the vent adaptor must protrude upward into the bowl (5) during installation. This is necessary to promote adequate gas venting during liquid drainage.



Make sure that the isolation valve between the water separator and the drain valve is open prior to compressor operation. Failure to do so will prevent the drainage of separated water and will flood air lines beyond the package discharge with water.

SECTION 7 AIR FILTER

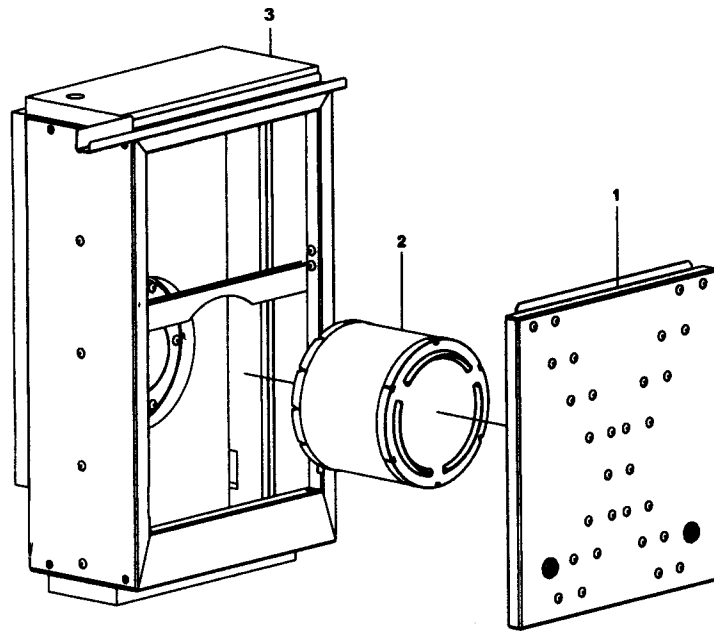

Figure 7-1 – AIR FILTER (STANDARD)

AIR FILTER - This device cleans the air stream entering the compressor inlet and is furnished as standard equipment with the compressor package. Its single high efficiency, synthetic media element is housed in a metal housing integrated in the enclosure structure.

Efficient compressor package operation depends on the unrestricted, clean supply of fresh air delivered by the air filter. In turn, the longevity of the filter element depends on the cleanliness of the local environment.

NOTICE

Use only genuine Gardner Denver air filter elements on Gardner Denver compressor units. Genuine parts are available through your authorized Gardner Denver distributor.

⚠ CAUTION

Do not oil this element. Do not wash in inflammable cleaning fluids. Do not use solvents other than water. Improper cleaning may damage the element.

NOTICE

Never operate the unit without the air filter element. Never use elements that are damaged, ruptured or wet. Keep spare elements on hand to reduce downtime. Store elements in a protected area free from damage, dirt and moisture. Handle all parts with care.

Filter Element Inspection and Replacement:

1. Remove air cleaner cover (1) and remove filter element.
2. Visually inspect housing inner tube against which the element makes a seal. Wipe dirt from outer surface if necessary. Also visually inspect the matching o-ring seal that is bonded to the element for defects and dirt, then wipe clean if necessary.
3. Visually inspect media. If flaws (e.g., tears of media, damage to sealing o-ring, etc.) are evident or if the pressure loss has triggered the vacuum switch (activation level is 30 inches water gauge) provided with the package instrumentation, replace the element. Cleansing the element with air or water is not recommended, as media damage is very probable.
4. Replace element and cover and fasten cover to filter housing.

SECTION 8 SHAFT COUPLING

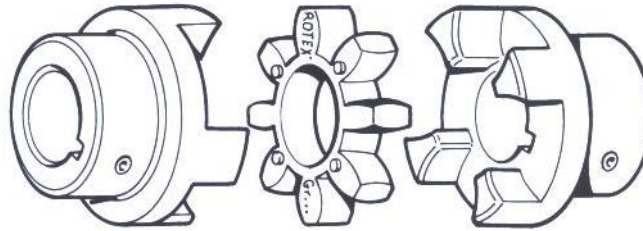

Figure 8-1 – COUPLING COMPONENTS



Rotating machinery can cause personal injury or death. Turn the unit completely off, open the main disconnect, lockout and tagout before servicing the coupling.

SHAFT COUPLING – Main motors drive their companion compressors by means of curved jaw-type couplings. Each coupling hub is fixed to the shaft with a setscrew and key combinations. The power is transmitted through a meshing, single, dry, vibrations damping element – see Figure 8-1, for details of the main components.

The close-coupled arrangement of motor and compressor, through a machined cast housing, provides automatic alignment of shafts and coupling. The coupling assembly requires no lubrication.

Coupling Element (Rotex size 48) Inspection and Replacement:

1. Disconnect, lockout and tagout power supply to the compressor package.
2. Remove fasteners securing coupling guard to access opening on compressor-motor housing and remove guard.
3. Depending on the bore-to-shaft fits (e.g., clearance or interference) on either of the coupling hubs proceeds as directed. For hub-to-shaft clearance fit hubs:
 - Loosen setscrews fastening hubs to shafts and slide hubs away from each other to allow removal of coupling element. Note that if the hubs do not slide on the shafts after this step, they should be considered interference fitted, thus proceed directly to Step 4, for further removal instructions.
 - Inspect coupling element for signs of wear and tear such as indentations, cracks, deformation, extrusions, etc. Replace, if necessary.
 - After engaging each hub on the matching recesses of the coupling element, check that the gap between the hub flats (see dimension “E” on Figure 8-2) is within 1.10/1.19 in (28.0/30.1 mm). A smaller gap will produce abnormal wear of the element by friction and excessive thermal expansion – the latter could cause compressor damage by axially displacing the input shaft. Make sure that keys are in proper alignment with key-ways on hubs.
 - Apply a thread-locking compound to the hub set screws (M8 size) and tighten to 7.4 lb-ft (10 N-m) of torque. Reinstall coupling guard with provided fasteners.

Components

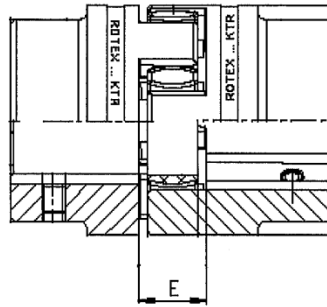
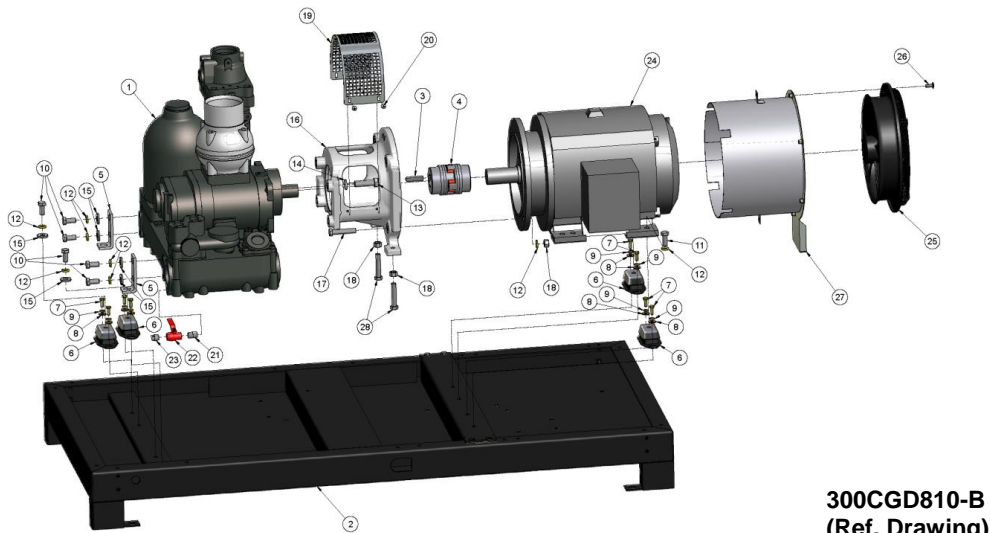

Figure 8-2 – COUPLING ELEMENT

4. For hub-to-shaft interference fit hubs, main drive motor removal is necessary:



**300CGD810-B
(Ref. Drawing)**

Figure 8-3 – MOTOR REMOVAL HARDWARE

- Remove coupling guard (19) by removing four bolts
- Remove two bolts securing (cooling fan) support (27) to base frame (2)
- Remove four bolts securing (main motor) rear support to base frame (2)
- Remove upper two bolts securing main motor (24) to adaptor (16) and replace with longer versions provided with package – there should be 3-in gap between bolt head and adaptor.
- Slide/Pull main motor (24) away from adaptor (16) until coupling hubs separate and allow removal of spider.
- Inspect coupling element for signs of wear and tear such as indentations, cracks, deformation, extrusions, etc. Replace, if necessary.
- Re-assemble main motor and cooling fan components in reverse.
- After engaging each hub on the matching recesses of the coupling element, check that the gap between the hub flats (see dimension “E” on Figure 8-2) is within 1.10/1.19 in (28.0/30.1 mm). A smaller gap will produce abnormal wear of the element by friction and excessive thermal expansion – the latter could cause compressor damage by axially displacing the input shaft. Make sure that keys are in proper alignment with key-ways on hubs.
- Apply a thread-locking compound to the hub setscrews (M8 size) and tighten to 7.4 lb-ft (10 N-m) of torque. Reinstall coupling guard with provided fasteners

Interference-fitted Coupling Hub Installation and Removal – In the event that a coupling hub has to be removed, please note that these are designed to fit on compressor and motor shafts with a transitional interference fit. Coupling hubs and their companion shafts which have bore diameters which fall in the interference range of the design fit must be installed or removed with the aid of a pulling tool and/or heat dilation. The recommended steps are based on the assumption that the main motor has been pulled away from the compressor and that the motor adaptor housing is still attached to the compressor.

Coupling Hub Installation:

- Have coupling installation tool part number CC1021460 available – contact Gardner Denver for sourcing details.
- Mount coupling hub unto tool via provided magnets.
- Make sure that the keyway on the coupling hub and its companion shaft are properly de-burred, cleaned and that the key fits easily into either.
- Thoroughly cleanse the surface of the companion shaft and cover it with a film of anti-seize lubricant part number 25BC850 – contact Gardner Denver for sourcing details.
- Expose hub and tool assembly to the heat source until the hub reaches a temperature of 200° F. Note that an oven is a preferred method to heat up the hardware.
- With the help of insulating gloves, remove the hub and tool assembly from the heat source and quickly bring it to the companion shaft. Engage the coupling hub bore onto the companion shaft and slide it until the latter contacts the stop. Refer to Figure 8-5 and Figure 8-6, for details of typical tool aligning the coupling hub onto the compressor and motor shafts, respectively. Note that hub-to-shaft alignment distances are different.
- Once the hub has cooled down sufficiently to the grip the companion shaft, remove the installation tool.
- Apply a thread-locking compound to the hub setscrews (M8 size) and tighten to 7.4 lb-ft (10 N-m) of torque. Reinstall coupling guard with provided fasteners.

Coupling Hub Removal:

- Have removal tool part number 90500151 available – contact Gardner Denver for sourcing details.
- Before removing an interference-fitted hub, note and record the position of the hub with respect to the end of the companion shaft. This is particularly critical if an installation tool is not available.
- Assemble the removal tool onto the hub as shown in Figure 8-4. Make sure that the shaft protector piece is captured between the puller screw and the end of the shaft
- Apply torque to the puller screw with a suitable torque wrench in order to pull hub away from the shaft. If the torque applied to the puller exceeds 130ft-lb (14.7N-m), it indicates that a heavy interference fit between the hub and the shaft exists and heat dilation must be used to expand the hub and loosen its grip on the shaft surface. Secure a suitable heating source and apply heat the hub body while slowly rotating the shaft by means of the removal tool handle. Once the hub body has expanded enough, the present tension of the removal tool will pull the hub away from the shaft.



Heated surfaces of coupling hubs and installation or removal tools may cause severe burns. Make sure to use suitable heat protective gloves and clothes.

NOTICE

If heat was applied to the [compressor] coupling hub during its removal, there is the possibility that the compressor shaft seal was damaged and it must be replaced. Contact Gardner Denver for further instructions.



Figure 8-4 – COUPLING REMOVAL TOOL

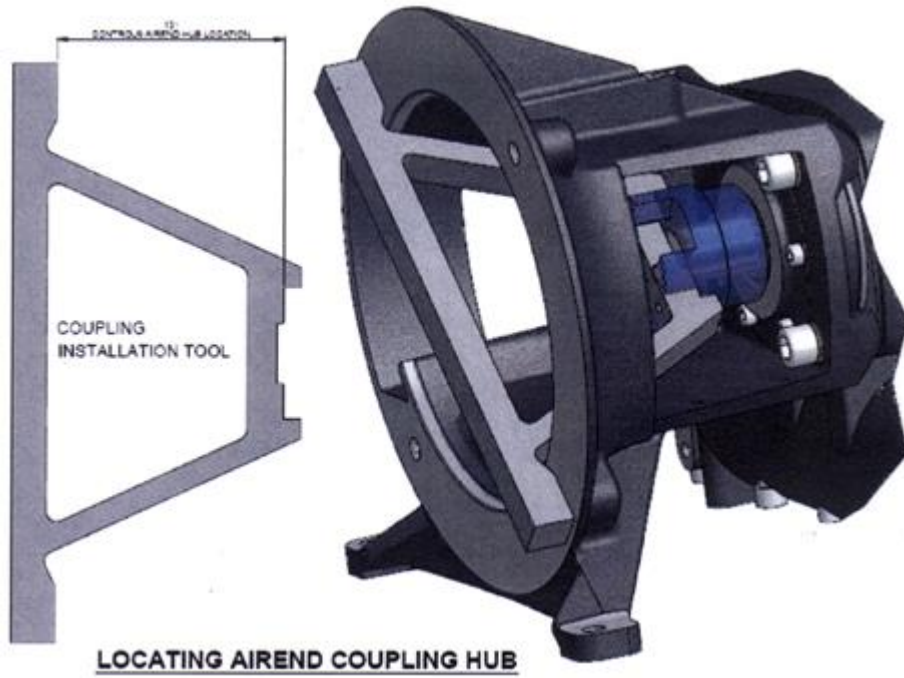

Figure 8-5 – LOCATION AIREND COUPLING HUB INSTALLATION TOOL

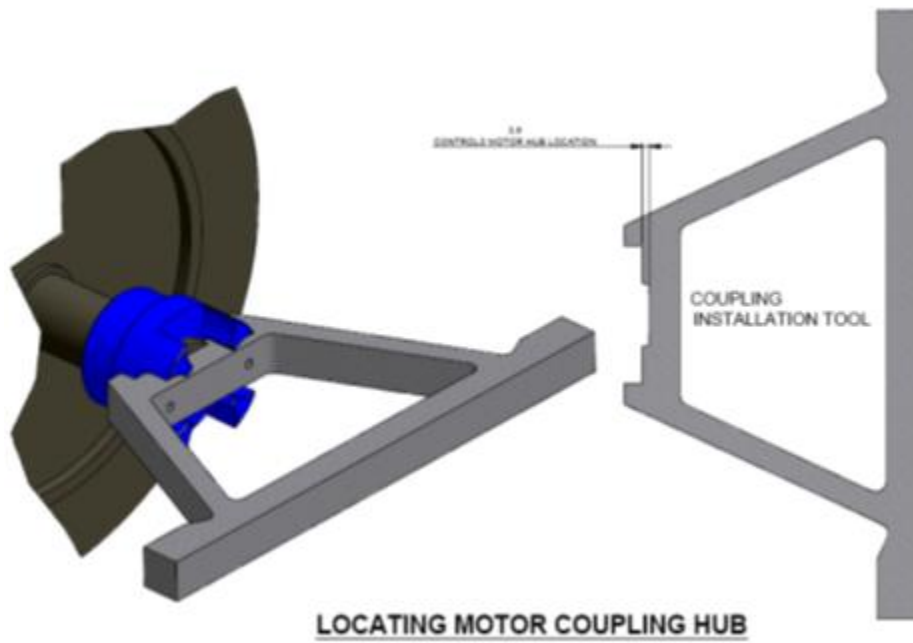

Figure 8-6 – LOCATING MOTOR COUPLING HUB INSTALLATION TOOL

SECTION 9

MINIMUM PRESSURE/CHECK VALVE

MINIMUM PRESSURE/CHECK VALVE - This device maintains minimum pressure within the air/oil reservoir, thus insuring (cooling/lubricating) oil injection flow into the compressors. It also serves as a check valve to prevent back flow of compressed air flow from the customer's piping or pipe network back into the compressor package when the compressor is not active.

The valve does not require maintenance or (internal) adjustment, but its operation relies on the pneumatic signal provided by an external pressure regulator (see Item S on Figure 4-2, page 29). If the valve fails to function:

- Check that the external pressure regulator is adjusted to allow the minimum pressure valve to crack open at 80 psig. Note that there are no serviceable parts in the pressure regulator; thus, it must be replaced as a unit in case of malfunction.
- Check internal components in the minimum pressure valve such as seals and seat (Item 2, 3, 4 and 18 in Figure 9-1, page 69) for signs of damage. Repair kits are available from your local authorized Gardner Denver distributor.



Before servicing the minimum pressure valve, always stop the unit, release air pressure, lockout and tagout the power supply to the compressor package. Failure to release pressure or properly disconnect the power may result in personal injury or death.

NOTICE

Working spring within valve body is under tension. Failure to relieve spring tension gradually may cause serious injury upon cap removal.

Minimum Pressure/Check Valve (MPV) Inspection:

1. Be sure the unit is completely off and that the oil sump is depressurized – including pipe works between MVP and (external) isolation valve.
2. Disconnect, lockout and tagout power supply to the compressor package.
3. Remove tubing and fittings from top (center) of MPV.
4. Install (removal) bolt (5), located on side of MPV housing, on top, center hole of MPV and tighten nut (7) securely. Note that this bolt keeps internal MPV parts from flying apart under spring pressure during removal.

5. Remove snap ring on MPV cover, remove cover and gently pry out MPV.
6. Gradually back off nut (7) while keeping bolt (5) from turning until spring pressure is released. Remove MPV internal parts. Inspect and/or replace parts.
7. Re-assemble in reverse order.

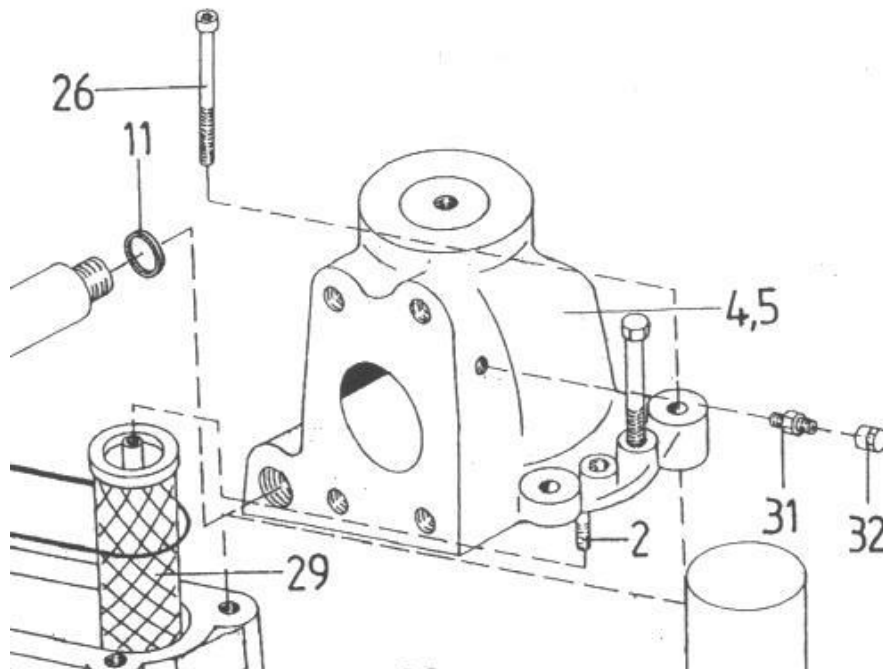
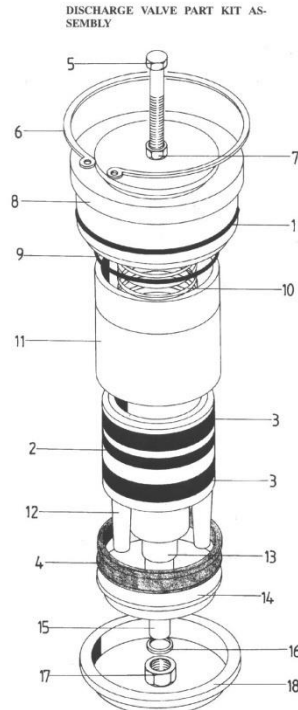

Figure 9-1 – MINIMUM DISCHARGE PRESSURE/CHECK VALVE

SECTION 10

INLET CONTROL VALVE

INLET CONTROL VALVE – This device is located at the intake flange of the compressor, and allows the compressor to remain pressurized and ready for quick response to air demand when the latter is not running.

During compressor operation, the underside of the poppet is vented to atmosphere via a 3-way solenoid valve, allowing the poppet to fall (open) and feed fresh air to the compressor inlet. An internal self-actuated blow-off valve assist in the fast venting of the air signal trapped below the poppet. During stopped operation modes (e.g., commanded from keypad or initiated by protective shutdown), the 3-way solenoid valve feeds an air signal to the underside of the poppet, forcing it upward (closed) and block off the compressor intake. The internal blow-off valve is also forced closed by the incoming air signal.

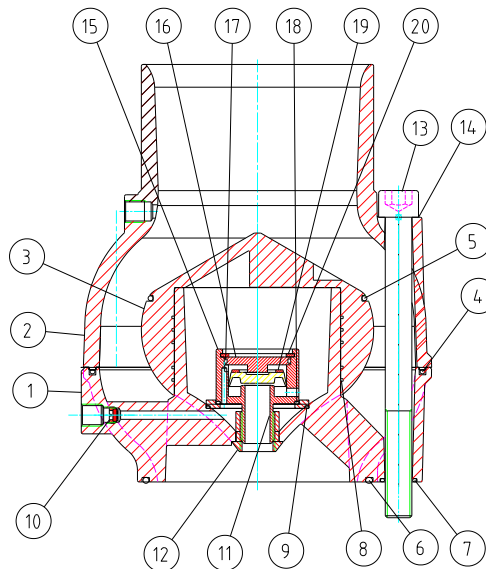

Figure 10-1 – INLET CONTROL VALVE

Inlet Control Valve (Body) Inspection - The valve does not require maintenance or lubrication. If air/oil leaks develop across the valve disc during pressurized conditions (e.g., machine stopped), valve seals should be inspected for wear and tear signs:

8. Be sure the unit is completely off and oil sump is depressurized.
9. Disconnect, lockout and tagout power supply to the compressor package.
10. Close (when provided) valve isolating compressor package from air system.
11. Identify (by position) each tube connected to the valve body and remove.
12. Remove four bolts (Item 13) securing valve body to compressor body and remove valve.
13. Inspect poppet seal (o-ring) (Item 5) for wear and tear. Replace, if necessary.
14. In case of noted malfunction (e.g., valve will not open/close properly with good air signal), proceed to dismantle internal blow-off valve.
 - Carefully lift and remove poppet (Item 3).
 - Remove lock ring (Item 20).
 - Pull cover (Item 16) and seal (Item 17).
 - Inspect seals (Items 18 & 19) for wear and tear. Replace if necessary.
 - Re-assemble blow-off valve in reverse order.
15. Reassemble inlet control valve in reverse order.

SECTION 11 PRESSURE RELIEF VALVE

Pressure Relief Valve - This device protects the pressure-containing components of the compressor package against pressures exceeding 188.5 psig. It is installed on the dry-side of the oil sump.

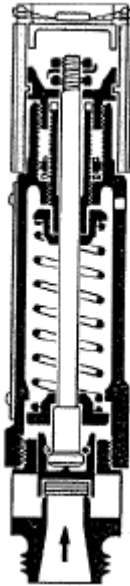

Before inspecting the pressure relief valve, release air pressure, lockout and tagout the power supply to the compressor package. Failure to release pressure or properly disconnect the power may result in personal injury or death.



Never paint, lubricate or alter a relief valve. Do not plug vent or restrict.



Operation of the unit with improper relief valve setting can result in severe personal injury or machine damage. Ensure properly set valves are installed and maintained.

Pressure Relief Valve Check During Operation – The pressure relief valve has no user-serviceable or repairable components. However, it should be tested for proper operation at least once every year. To test the pressure relief valve:

- Raise the system operating pressure to its normal level
- Turn the top cap on valve 1-2 turns counter-clockwise to open valve and let it vent for a few seconds.
- Close the valve by firmly turning top cap clockwise. Make sure that cap is firmly tightened to avoid damage by vibrations.

SECTION 12

VENTILATION FILTERS (ELECTRICAL ENCLOSURE)

Ventilation Filters - The electronics housed in the standard IP54 enclosure box are ventilated by a combination of an intake air filter and pressurized air provided by the heat exchanger cooling fans.

Filter Inspection - In order to ensure the electronics operate at peak efficiency and free from troublesome temperature-related stoppages, it is imperative that the filter elements be kept clean:

1. Be sure the unit is completely off and oil reservoir is depressurized.
2. Disconnect, lockout and tagout power supply to the compressor package.
3. To service intake-side filter, open access door (oil filter side) and remove (latched) access door located on cooler housing cover – Refer to Fig 6-2 for details.
4. To service discharge-side filter, open access door (dryer side) and reach behind electrical box.
5. Remove filter elements from each bracket by prying open the retaining grill area.
6. Inspect the elements. If dirty, gently clean with soapy water and allow to dry completely before re-installation. If damage is evident, replace.
7. Replace elements into frame and replace snap grills.
8. Replace access panel in reverse order.
9. Close access doors.

**SECTION 13
MOTOR LUBRICATION**



Rotating machinery can cause injury or death. Open main disconnect, lockout and tagout power supply to compressor package before working on the electric motor.

Motor Lubrication - Long time satisfactory operation of an electric motor depends in large measure on proper lubrication of the bearings. The following charts show recommended grease qualities and re-greasing intervals for ball bearing motors. For additional information refer to the motor manufacturer's instructions. The following procedure should be used in re-greasing:

1. Disconnect, lockout and tagout power supply to the compressor package.
2. Locate the automatic grease relief fittings (one at each motor bottom end) and make sure that their spring loaded covers are operational.
3. Locate the grease fittings provided at each end of the motor top end – be aware the one or both may be relocated away from the motor for easier access. Wipe each greased fitting clean and add grease with a hand - operated gun until excess grease starts draining from the companion grease relief fitting.
4. Wipe off only excess grease expelled by the automatic grease relief fittings.
5. Re-start the unit.

Main Motor Grease Specifications:

MANUFACTURER	TRADE NAME	GD Part No.
KLUBER	KLUBER QUIET BQ 72-72	28H311 (400 Gram Cartridge) 28H312 (1Kg can) 28H313 (25 Kg pail)

ELECTRIC MOTOR REGREASING INTERVAL

Type of Service	Typical	Rating	Lubrication Interval
ALL	Continuous Operation Humid, dirty, high ambient sites	45-70 kW	5000 hrs

SECTION 14

MAINTENANCE SCHEDULE

SERVICE CHECK LIST

Daily Checks:

- **Air Filter (Compressor)** - Replace when controller displays “CHANGE AIR FILTER” message. Refer to Section 7 for air filter details.
- **Oil Separator Element** - Replace when controller displays “CHANGE OIL SEPARATOR ELEMENT”. Refer to Section 5 for oil separator element details.
- **Air/Oil Reservoir Oil Level** - Check the reservoir oil level with compressor stopped only - add oil if required. Refer to Section 5 for full details. **DO NOT MIX LUBRICANTS.**
- **Start/Modulation/Stop Operation** – Verify that compressors maintain steady compressed air pressure.
- **AirSmart Operational Parameters** – Maintaining a periodic log of package critical parameters (e.g., pressures, temperatures, speeds, load levels, etc) helps identify when abnormal operation occurs.
- **AirSmart Controller Messages and Alarms** – Acknowledge the presence of an abnormal condition and take action to correct it.

Weekly Checks:

- **Heat Exchangers (air-cooled)** - Check for dirt accumulation on (air-cooled) air/oil heat exchanger finned surfaces. Refer to Section 6 for detailed instructions to clean heat exchanger surfaces.
- **Axial cooling fans** – Check for grime and dirt build-up on fan blade surfaces. Refer to Section 6 for detailed instructions to clean axial cooling fan blade surfaces
- **Air Filter (Electrical Box)** – Check filter elements for dirt accumulation. Refer to Section 12 for detailed instruction to clean filter elements.

Every 1000 Hours or as often as operating conditions require it:

- **Oil Filter** - Replace.
- **Oil** - Sample and analyze.

Every 3000 Hours or as often as operating conditions require it:

- **Motor Lubrication** – Inspect motors for abnormal noise and vibration. Grease-lubricate with proper grease as shown in Section 13, page 74.

Every 8000 Hours (or as Prescribed by Oil Analysis Results):

1. **Compressor Lubricant** – Replace.

Yearly Checks:

- **Heat Exchangers (air and water-cooled)** – Check cooling performance of air and oil cores – see Section 6 of this manual for details on typical performance expectations as well as recommended cleaning procedures.
- **Pressure Relief Valve** – Check operation of device – see Section 11 for test procedure.
- **Motor Lubrication** – Inspect motors for abnormal noise and vibration. Grease-lubricate per guidelines included in Section 13 of this manual.
- **Compressor/Motor shaft couplings** – Check coupling element for signs of wear and tear – see Section 8 for detailed instruction on coupling inspection procedures.

SECTION 15 TROUBLESHOOTING



Air/oil under pressure will cause severe personal injury or death. Shut down compressor, relieve system of all pressure, disconnect, lockout and tagout power supply to the compressor package before removing valves, caps, plugs, fittings, bolts and filters.

SYMPTOM	POSSIBLE CAUSE	REMEDY
Compressor fails to start	1. Main disconnect open	1. Check and reset.
	2. Blown fuses in control box	2. Check voltage and fuses. Replace fuses.
	3. Shutdown event sensed by controller not re-set	3. Investigate cause of fault and press "STOP/RESET" button to reset.
	4. Read error message on control panel	4. Take appropriate action. See Manual 13-17-600.
	5. Remote Contact is open	5. Replace switch or jumper.
	6. Variable Frequency Drive fault active	6. Investigate and correct cause of fault and press "STOP/RESET" button to reset.
	7. System pressure exceeds set pressure	7. Wait until system pressure falls below set pressure.
Compressor starts but stops after a short time	1. High discharge temperature	1. See "High Discharge Air Temperature," this section.
	2. Low oil injection pressure	2. Check oil filter dP.
	3. Blown fuse in control box	3. Replace fuse (investigate if fuses continue to blow).
	4. Variable Frequency Drive overload sensor tripped	4. Reset and investigate cause of overload.

SYMPTOM	POSSIBLE CAUSE	REMEDY
Compressor does not unload (or load)	1. Improperly adjusted controller	1. Refer to Manual 13-17-600 and adjust control.
	2. Feed pressure regulator not adjusted	2. Inspect, adjust and replace pressure regulator.
	3. Feed 3-way solenoid valve malfunction	3. Repair, clean or replace valve.
	4. Inlet valve stuck	4. Inspect and replace valve.
	5. Blow down valve malfunction	5. Repair, clean or replace valve.
Compressor cycles from load to unload excessively	1. Insufficient receiver capacity	1. Increase receiver size
	2. Restriction in service piping	2. Inspect and clean service piping.
	3. Restriction in control tubing	3. Inspect and clean control tubing.
Compressor starts too slowly	1. Acceleration time in VFD set too long	1. Contact your Gardner Denver distributor.
	2. Minimum Pressure/Check Valve is leaking	2. Repair or replace.
Compressor is low on delivery and pressure	1. Improperly adjusted control	1. Refer to Manual 13-17-600 and adjust control.
	2. Restricted air filter	2. Clean or replace filter element.
	3. Inlet valve not fully open	3. Inspect, adjust or replace feed solenoid valve and/or pressure regulator.
	4. Minimum pressure valve stuck closed	4. Inspect, service or replace valve.
	5. Blowdown valve leaking	5. Inspect or replace solenoid valve. Ensure local ambient temperature has not exceeded 113°F. limit.
	6. Air demand exceeds supply	6. Make sure air demand matches compressor specifications for flow and pressure.

SYMPTOM	POSSIBLE CAUSE	REMEDY
Excessive oil consumption	1. Oil separation malfunction	1. See "Oil Carryover" in this section.
	2. Oil leaks at fittings and gaskets	2. Detect and correct oil leaks.
	3. Shaft seal leaking	3. Inspect or replace shaft seal.
High discharge air, oil Temperature (air, water cooled cores)	1. Oil mixing valve stuck on bypass mode	1. Check 24dvcv power feed to servo. Check ModBus connection to servo. Check servo-to-valve coupling. Check rotation of ball valve.
	2. Clogged oil filter	2. Inspect and replace filter.
	3. Clogged cooler (interior)	3. Inspect and clear cooler.
	4. Clogged oil lines	4. Inspect and clear oil lines.
	5. Low oil level	5. Add oil to proper level.
High discharge air, oil Temperature (air cooled cores)	1. Dirty or clogged cooler outer surfaces.	1. Inspect and clean cooler outer surfaces.
	2. Insufficient cooling air flow	2. Verify (ductwork) back pressure does not exceed .1" water gauge.
High discharge air, oil Temperature (water cooled cores)	1. Optional water temp regulating or shut-off valve malfunction	1. Refer to Section 6 "Heat Exchangers" for details.
	2. Insufficient cooling water flow	2. See Section 6 for details on adequate cooling water flow rates.
VFD Shutdown on Overheat	1. Ambient temperature exceeds 45°C	1. Check location ventilation and improve if necessary.
	2. VFD air filters dirty	2. Inspect, clean or replace elements.

SYMPTOM	POSSIBLE CAUSE	REMEDY
Excessive oil at intake filter area	1. Intake valve seals leaking.	1. Check location ventilation and improve if necessary. Inspect, repair or replace valve.
	2. Slow intake valve poppet action	2. Inspect poppet and guide surfaces. Replace if necessary.
	3. Feed 3-way solenoid valve malfunction	3. Repair, clean or replace valve.
Oil carryover	1. Overfilling oil separation vessel	1. Drain excess oil from system.
	2. Clogged oil return line orifice	2. Inspect and service.
	3. Clogged oil return line strainer	3. Inspect and service.
	4. Clogged, broken, or loose oil return line fittings	4. Inspect and tighten or replace.
	5. Ruptured oil separator element.	5. Replace element.
	6. Loose assembly	6. Tighten all fittings and gaskets.
	7. Foam caused by use of incorrect oil	7. Use Gardner Denver AEON 9000SP oil only.
	8. Minimum pressure valve malfunction – discharge pressure below 80 psig	8. Repair or replace. Inspect, adjust or replace regulator.

Standard Warranty

Oil-Lubricated Rotary Screw / Rotary Vane Compressor Packages

APEX, APEX VS, Electra Screw, Integra, Electra Saver II, Electra Saver, L, LRS, VS, VST, V, HV, HV RS, and HR Series

STANDARD WARRANTY

Gardner Denver (the “Company”) warrants to each original retail purchaser (“Purchaser”) of its new products from the Company or its authorized distributor that such products are, at the time of delivery to the Purchaser, free of defects in material and workmanship. **This Standard Warranty statement applies to compressors shipped after April 1st, 2015.**

STANDARD WARRANTY PERIOD

The Company’s obligation under this warranty is limited to repairing or, at its option, replacing, during normal business hours at an authorized service facility of the Company, any part which in its judgment proved not to be as warranted within the applicable warranty period as follows. **Regular maintenance in accordance with the service manual is required. Use of genuine Gardner Denver OEM parts and lubricants are highly recommended. If a component failure is deemed a result of using non-genuine Gardner Denver parts and lubricants, warranty will not be allowed.**

COMPONENT	STANDARD WARRANTY COVERAGE	DETAILS
Package	12 months from startup or 15 months from date of shipment to first purchaser, whichever occurs first	All components within the package, excluding normal wear items
Airend	24 months from startup or 27 months from date of shipment to first purchaser, whichever occurs first	Normal wearing items, such as shaft seals and inlet valve components, along with the servicing of these items is not covered under the warranty unless deemed as material or workmanship defects. Any disassembly or partial disassembly of the airend, or failure to return the “unopened” airend per Company instructions, will be cause for denial of warranty
Electric Motors	12 months from startup or 15 months from date of shipment to first purchaser, whichever occurs first	Includes both drive motor and cooling fan motor. For nonstandard motors, the original manufacturer’s warranty will take precedence.
Major Package Components	24 months from startup or 27 months from date of shipment to first purchaser, whichever occurs first	Includes package controller, variable frequency drive if applicable, air/oil reservoir, air/oil cooler, and precision mixing valve (VS Series)
Labor	<p>Package / Electric Motors: 12 months from startup or 15 months from date of shipment to first purchaser, whichever occurs first</p> <p>Airend / Major Package Components: 24 months from startup or 27 months from date of shipment to first purchaser, whichever occurs first</p>	Service will be provided by Company representative or authorized service personnel, for repair or replacement of any product or part which in the Company’s sole judgment is proved not to be as warranted. Labor shall be limited to the amount specified in the Company’s labor rate schedule. All costs of transportation of product, parts, and repaired or replacement parts claimed not to be as warranted to and from such service facilities shall be borne by the Purchaser. The Company may require the return of any part claimed not to be as warranted to one of its facilities as designated by Company, transportation prepaid by Purchaser, to establish a claim under this warranty. Replacement parts provided under the terms of the warranty are warranted for the remainder of the Warranty Period.

NO WARRANTY IS MADE WITH RESPECT TO:

1. ANY PRODUCT WHICH HAS BEEN REPAIRED OR ALTERED IN SUCH A WAY, IN THE COMPANY’S JUDGMENT, AS TO AFFECT THE PRODUCT ADVERSELY
2. ANY PRODUCT WHICH HAS, IN THE COMPANY’S JUDGMENT BEEN SUBJECT TO NEGLIGENCE, ACCIDENT, IMPROPER STORAGE, OR IMPROPER INSTALLATION OR APPLICATION
3. ANY PRODUCT WHICH HAS NOT BEEN OPERATED OR MAINTAINED IN ACCORDANCE WITH THE RECOMMENDATIONS OF THE COMPANY
4. ANY RECONDITIONED OR PRIOR OWNED PRODUCT

STANDARD WARRANTY DISCLAIMER

THE FOREGOING WARRANTY IS EXCLUSIVE AND IT IS EXPRESSLY AGREED THAT, EXCEPT AS TO TITLE, THE COMPANY MAKES NO OTHER WARRANTIES AND HEREBY EXPRESSLY DISCLAIMS ALL OTHER WARRANTIES, INCLUDING WITHOUT LIMITATION, EXPRESSED, IMPLIED OR STATUTORY WARRANTIES, INCLUDING ANY IMPLIED WARRANTY OF MERCHANTABILITY OR FITNESS FOR A PARTICULAR USE. THE REMEDY PROVIDED UNDER THIS WARRANTY SHALL BE THE SOLE, EXCLUSIVE AND ONLY REMEDY AVAILABLE TO PURCHASER AND IN NO CASE SHALL THE COMPANY BE SUBJECT TO ANY OTHER OBLIGATIONS OR LIABILITIES. UNDER NO CIRCUMSTANCES SHALL THE COMPANY BE LIABLE FOR SPECIAL, INDIRECT, INCIDENTAL OR CONSEQUENTIAL DAMAGES, EXPENSES, LOSSES OR DELAYS HOWSOEVER CAUSED. NO STATEMENT, REPRESENTATION, AGREEMENT, OR UNDERSTANDING, ORAL OR WRITTEN, MADE BY ANY AGENT, DISTRIBUTOR, REPRESENTATIVE, OR EMPLOYEE OF THE COMPANY WHICH IS NOT CONTAINED IN THIS WARRANTY WILL BE BINDING UPON THE COMPANY UNLESS MADE IN WRITING AND EXECUTED BY AN OFFICER OF THE COMPANY. THIS WARRANTY SHALL NOT BE EFFECTIVE AS TO ANY CLAIM WHICH IS NOT PRESENTED WITHIN 30 DAYS AFTER THE DATE UPON WHICH THE PRODUCT IS CLAIMED NOT TO HAVE BEEN AS WARRANTED. ANY ACTION FOR BREACH OF THIS WARRANTY MUST BE COMMENCED WITHIN ONE YEAR AFTER THE DATE UPON WHICH THE CAUSE OF ACTION OCCURRED. ANY ADJUSTMENT MADE PURSUANT TO THIS WARRANTY SHALL NOT BE CONSTRUED AS AN ADMISSION BY THE COMPANY THAT ANY PRODUCT WAS NOT AS WARRANTED. WARRANTY IS NOT TRANSFERABLE

Gardner Denver®

For additional information, contact your local representative or visit:
www.contactgd.com/compressors

©2018 Gardner Denver, Inc. Printed in U.S.A.



Member



Please recycle after use.