



13-17-605
Version: 12
May 11, 2016

**VARIABLE SPEED
TWO-STAGE
STATIONARY BASE-MOUNTED
COMPRESSOR**

AirSmart™ CONTROLLER

**MODELS
VST110, 150, 180A**

110-150-180kW

60HZ

**OPERATING AND
SERVICE MANUAL**

**MAINTAIN COMPRESSOR RELIABILITY AND PERFORMANCE WITH
GENUINE GARDNER DENVER® COMPRESSOR PARTS AND SUPPORT SERVICES**

Gardner Denver® Compressor genuine parts, manufactured to design tolerances, are developed for optimum dependability . specifically for Gardner Denver compressor systems. Design and material innovations are the result of years of experience with hundreds of different compressor applications. Reliability in materials and quality assurance is incorporated in our genuine replacement parts.

Your authorized Gardner Denver Compressor distributor offers all the backup you need. An AirSmart network of authorized distributors provides the finest product support in the air compressor industry.

Your authorized distributor can support your Gardner Denver air compressor with these services:

1. Trained parts specialists to assist you in selecting the correct replacement parts.
2. Factory warranted new and remanufactured rotary screw airends. Most popular model remanufactured airends are maintained in stock at the factory, for purchase on an exchange basis with liberal core credit available for the replacement unit.
3. A full line of factory tested AEONi compressor lubricants specifically formulated for use in Gardner Denver compressors.
4. Repair and maintenance kits designed with the necessary parts to simplify servicing your compressor.

Authorized distributor service technicians are factory trained and skilled in compressor maintenance and repair. They are ready to respond and assist you by providing fast, expert maintenance and repair services.

To Contact Gardner Denver or locate your local distributor:

Visit: www.contactgd.com/compressors

Or

Call: (800)682-9868

INSTRUCTIONS FOR ORDERING REPAIR PARTS

When ordering parts, specify Compressor MODEL, Method of Cooling, POWER and SERIAL NUMBER (see nameplate on unit). The airend Serial Numbers are also stamped on top of the discharge bearing carrier castings.

All orders for Parts should be placed with the nearest authorized distributor.

Where NOT specified, quantity of parts required per compressor or unit is one (1); where more than one is required per unit, quantity is indicated in parenthesis. SPECIFY EXACTLY THE NUMBER OF PARTS REQUIRED.

DO NOT ORDER BY SETS OR GROUPS.

To determine the Right-Hand and Left-Hand side of a compressor, stand at the motor end and look toward the compressor. Right-Hand and Left- Hand are indicated in parenthesis following the part name, i.e. (RH) and (LH), when appropriate.

WARNING – PROHIBITION – MANDATORY LABEL INFORMATION

Gardner Denver Rotary Screw compressors are the result of advanced engineering and skilled manufacturing. To be assured of receiving maximum service from this machine, the owner must exercise care in its operation and maintenance. This book is written to give the operator and maintenance department essential information for day-to-day operation, maintenance and adjustment. Careful adherence to these instructions will result in economical operation and minimum downtime.

Boxed text formats are used, within this manual, to alert users of the following conditions:

Safety Labels are used, within this manual and affixed to the appropriate areas of the compressor package, to alert users of the following conditions:



Indicates a hazard with a high level of risk, which if not avoided, WILL result in death or serious injury.



Equipment starts automatically



Health Hazard . Explosive Release of Pressure



Cutting of Finger or Hand Hazard . Rotating impeller blade



High Voltage . Hazard of Shock, Burn, or Death Present until Electrical Power is Removed



Cutting of Finger or Hand Hazard . Rotating fan blade



Entanglement of Fingers or Hand/Rotating Shaft



Indicates a hazard with a medium level of risk which, if not avoided, **COULD** result in death or serious injury.



Asphyxiation Hazard . Poisonous Fumes or Toxic Gases in Compressed Air



Indicates a hazard with a low level of risk which, if not avoided, **MAY** result in a minor or moderate injury.



Burn Hazard . Hot surface

PROHIBITION/MANDATORY ACTION REQUIREMENTS



Do not Operate Compressor with Guard Removed



Lockout Electrical Equipment in De-Energized State



Do Not Lift Equipment with Hook . No Lift Point



Loud Noise Hazard . Wear Ear Protection



Handle Package at Forklift Points Only



Read the Operator's Manual Before Proceeding with Task

SAFETY PRECAUTIONS

Safety is everybody's business and is based on your use of good common sense. All situations or circumstances cannot always be predicted and covered by established rules. Therefore, use your past experience, watch out for safety hazards and be cautious. Some general safety precautions are given below:



Failure to observe these notices could result in injury to or death of personnel.

- **Keep fingers and clothing away** from rotating fan, drive coupling, etc.
- **Disconnect the compressor unit** from its power source, lockout and tagout before working on the unit – this machine is automatically controlled and may start at any time.
- **Do not loosen or remove** the oil filler plug, drain plugs, covers, the thermostatic mixing valve or break any connections, etc., in the compressor air or oil system until the unit is shut down and the air pressure has been relieved.
- **Electrical shock** can and may be fatal.
- **Perform all wiring** in accordance with the National Electrical Code (NFPA-70) and any applicable local electrical codes. Wiring and electrical service must be performed only by qualified electricians.
- **Open main disconnect switch**, lockout and tagout before working on the control, wait 10 minutes and check for voltage.



Failure to observe these notices could result in damage to equipment.

- **Stop the unit** if any repairs or adjustments on or around the compressor are required.
- **Do not use the air discharge** from this unit for breathing – not suitable for human consumption.
- **An Excess Flow Valve** should be on all compressed air supply hoses exceeding 1/2 inch inside diameter (OSHA Regulation, Section 1926.302).
- **Do not exceed** the rated maximum pressure values shown on the nameplate.
- **Do not operate unit** if safety devices are not operating properly. Check periodically. Never bypass safety devices.

TABLE OF CONTENTS

Maintain Compressor Reliability And Performance With Genuine Gardner Denver Compressor Parts And Support Services	1
Instructions For Ordering Repair Parts	1
Warning . Prohibition . Mandatory Label Information	2, 3
Safety Precautions	4
Index	6
List Of Illustrations	7
Section 1, General Information	8
Section 2, Installation.....	14
Section 3, Starting & Operating Procedures.....	21
Section 4, Controls & Instrumentation.....	28
Section 5, Compressor Lubrication - Separation, Filtration And Controls	42
Section 6 - Heat Exchangers (Oil, Air), Axial Cooling Fans.....	52
Section 7, Air Filter	57
Section 8, Shaft Coupling	59
Section 9, Minimum Pressure/Check Valve.....	65
Section 10, Inlet Control Valve.....	67
Section 11, Pressure Relief Valve.....	69
Section 12, Ventilation Fans, Filters (Electrical Enclosure)	71
Section 13, Motor Lubrication	72
Section 14, Maintenance Schedule.....	73
Section 15, Troubleshooting	75

This book covers the following models:

KW	PSIG	Air Cooled and Water Cooled	Parts List	Controller Manual	Communication Module
110, 150, 180	100 THRU 175	VST110-180A	13-17-501	13-17-600	13-17-604

NOTICE

Gardner Denver factory remanufactured replacement compressor airend units are available from your authorized distributor, on an exchange basis, for all rotary screw compressor units.

INDEX

Air Filter.....	57	Oil Reservoir Drain.....	16
AIR FILTER, SECTION 7.....	57	Oil System	
Air Flow in the Compressor System	8	Addition of Oil Between Changes.....	45
Air-Cooled Units, Location	15	Compressor.....	42
Auxiliary Air Receiver.....	17	Draining and Cleaning	46
Cold Weather Installation.....	17	Refilling Oil System	47
Compression Principle.....	8	Low Air Demand and Package Operation ...	49
COMPRESSOR LUBRICATION .		Moisture	43
SEPARATION, FILTRATION AND		Oil Change Interval.....	46
CONTROLS, Section 5	42	Oil Filter.....	47
Control Piping.....	17	Oil Flow Control Valves	48
CONTROLS & INSTRUMENTATION, SECTION		Oil Mixing Valve.....	48
4	28	Oil Separation Reservoir/Coalescing Element	
Cooling, Sealing and Lubrication.....	9	50
Discharge Service Line.....	18	Oil Specifications.....	42
Electrical Wiring.....	18	Recommended Lubricant.....	42
Enclosure	16	Piping	
Filter Inspection.....	71	Blow Down Valve.....	18
Foundation	16	Control	17
GENERAL INFORMATION, SECTION 1	8	Water	18
GROUNDING.....	20	Pressure Differential Gauging.....	50
Heat Exchangers		Pressure Relief Valve.....	69
Air-Cooled.....	53	PRESSURE RELIEF VALVE, SECTION 11 ...	69
Oil/Air.....	52	Prestart-Up Instructions.....	21
Water-Cooled.....	54	Quick Start Guide.....	23
HEAT EXCHANGERS (OIL, AIR), AXIAL		SAFETY PRECAUTIONS	4
COOLING FANS Section 6	52	Sealing, Lubrication and Cleaning	9
Inlet Control Valve	67	Service Check List	73
INLET CONTROL VALVE, SECTION 10	67	Daily Checks	73
Inlet Line	17	Every 1000 Hours Operation.....	73
Installation For Cold Cold Weather Operation .	17	Every 3000 Hours Operation.....	73
INSTALLATION, SECTION 2.....	15	Every 8000 Hours Operation.....	73
Lifting Unit.....	15	Weekly Checks.....	73
Location	16	Yearly.....	74
Air-Cooled Units.....	16	SHAFT COUPLING.....	59
Water-Cooled Units.....	17	SHAFT COUPLING, SECTION 8	59
Lubrication, Cooling and Sealing.....	73	STARTING & OPERATING PROCEDURES,	
Main Motor Grease Specifications	73	SECTION 3	21
MAINTENANCE SCHEDULE, SECTION 14 ...	73	Starting the Unit	25
Minimum Pressure/Check Valve	65	Stopping the Unit	26
MINIMUM PRESSURE/CHECK VALVE,		TROUBLESHOOTING, SECTION 15.....	74
SECTION 9.....	65	VENTILATION FANS, FILTERS (ELECTRICAL	
Moisture Separator/Trap.....	17	ENCLOSURE), SECTION 12.....	71
Motor Lubrication.....	72	Ventilation Fans/Filters.....	71
Motor Lubrication.....	20	WARNING . PROHIBITION . MANDATORY	
MOTOR LUBRICATION, SECTION 13	72	LABEL INFORMATION	21
Oil Filter.....	47	Water-Cooled Units, Location.....	16

LIST OF ILLUSTRATIONS

Figure 1-1 . Compression Cycle.....	8
Figure 1-2 . Package Illustration (Air-Cooled) . External Details.....	10
Figure 1-3 . Package Illustration (Air-Cooled) . Internal Details.....	11
Figure 1-4 . Package Illustration (Water-Cooled) . External Details.....	12
Figure 1-5 . Package Illustration (Water-Cooled) . Internal Details.....	13
Figure 2-1 . Typical Compressor Room.....	15
Figure 2-2 . Inlet Line Lengths	17
Figure 2-3 . Package Maximum Current Consumption Summary.....	19
Figure 2-4 . Line Reactor Sizing Recommendations.....	20
Figure 4-1 . Electrical Enclosure Hardware	29
Figure 4-2 . Electrical Enclosure Hardware	30
Figure 4-3 . Piping And Instrumentation Illustration	33
Figure 4-4 . Wiring Diagram . (Air-Cooled) Two-Stage VS Control.....	34
Figure 4-5 . Wiring Diagram . (Air-Cooled) Two-Stage VS Control.....	35
Figure 4-6 . Wiring Diagram . (Air-Cooled) Two-Stage VS Control.....	36
Figure 4-7 . Wiring Diagram . (Air-Cooled) Two-Stage VS Control.....	37
Figure 4-8 . Wiring Diagram . (Water-Cooled) Two-Stage VS Control.....	38
Figure 4-9 . Wiring Diagram . (Water-Cooled) Two-Stage VS Control.....	39
Figure 4-10 . Wiring Diagram . (Water-Cooled) Two-Stage VS Control.....	40
Figure 4-11 . Wiring Diagram . (Water-Cooled) Two-Stage VS Control.....	41
Figure 5-1 . Oil Level Sight Glass.....	44
Figure 5-2 . Load VS Sight Glass Oil Level Change	44
Figure 5-3 . Combination Oil Filter And Thermostatic Mixing Valve.....	48
Figure 5-4 . Pressure Dew Point Of Compressed Air.....	49
Figure 5-5 . Oil Coalescing Element.....	50
Figure 6-1 . Air Flow Chart.....	53
Figure 6-2 . Cooler Housing Side Covers.....	54
Figure 6-3 . Water-Cooled Heat Exchanger Coolant Requirements	55
Figure 6-4 . Water Control Valve.....	56
Figure 7-1 . Air Filter (Standard).....	57
Figure 8-1 . Coupling Components.....	59
Figure 8-2 . Coupling Element	60
Figure 8-3 . Motor Removal Hardware	61
Figure 8-4 . Coupling Installation Tool Kit.....	64
Figure 8-5 . Coupling Removal Tool Kit.....	64
Figure 9-1 . Minimum Discharge Pressure/Check Valve.....	66
Figure 10-1 . Inlet Control Valve (Body)	67
Figure 11-1 . Pressure Relief Valve.....	69

SECTION 1 GENERAL INFORMATION

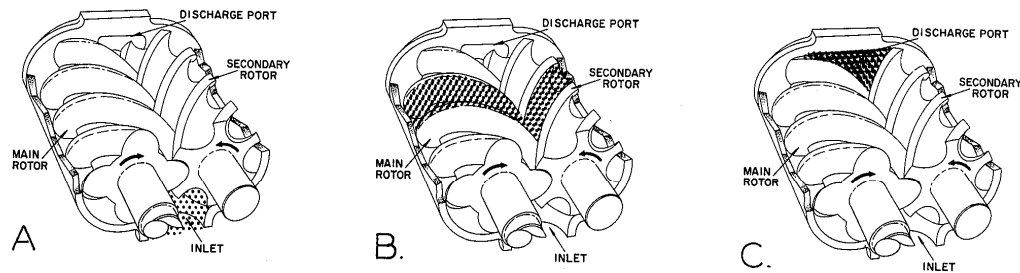

B74959A

Figure 1-1 – COMPRESSION CYCLE

COMPRESSOR . Your Gardner Denver Rotary Screw package is fitted with two (2) in-series single stage, positive displacement rotary compressors using meshing helical rotors to effect compression. Each pair of rotors is supported between high capacity anti-friction bearings located outside the compression chamber. Single cylindrical roller bearings are used at each end of the rotors to carry the radial loads. An additional angular contact ball bearing is located at the discharge end of each rotor to carry axial thrust loads. The main rotor sits atop its gate companion, in an over-under configuration that saves (compressor assembly) space and eases piping network.

COMPRESSION PRINCIPLE (Figure 1-1) - Compression is accomplished by the main and gate rotors synchronously meshing in a one-piece cylinder. The 1st stage main rotor has three (3) helical lobes, 120° apart, which mesh with five (5) helical grooves, 72° apart, on its matching gate rotor. The 2nd stage main rotor has four (4) helical lobes, 90° apart, which mesh with five (5) helical grooves, 72° apart, on its gate rotor.

The air inlet port is located on one side in of the compressor cylinder near the drive shaft end. The discharge port is in the diametrically opposite end of the compressor cylinder. Figure 1-1, *rotates compressor on its side to show inlet and discharge ports*. The compression cycle begins as the rotors unmesh at the inlet port and air is drawn into the cavity between the main rotor lobes and gate rotor grooves (A). When the rotors pass the inlet port cutoff, air is trapped in the interlobe cavity and flows axially with the meshing rotors (B). As meshing continues, more of the main rotor lobe enters the gate rotor groove, normal volume is reduced and pressure increases.

Oil is injected into the cylinder to remove the heat of compression and seal internal clearances. Volume reduction and pressure continues to increase until the air/oil mixture trapped in the interlobe cavity by the rotors passes the discharge port (C). Each rotor cavity follows the same fill-compress-discharge+cycle in rapid succession to produce a discharge air flow that is continuous, smooth and shock free.

AIR FLOW IN THE COMPRESSOR SYSTEM (Figure 4-3, page 33) - Air enters the air filters (two (2) used) and passes through the inlet butterfly valve to the 1st stage compressor. After compression, the air/oil mixture passes into the inter-stage manifold, where further oil injection may take place to maintain optimal system temperature, and is subsequently delivered to the 2nd stage compressor. After 2nd stage compression, the air/oil mixture enters the oil reservoir where most of the entrained oil is removed by centrifugal action and drained down into the reservoir. The air and remaining aerosols pass into two (2) coalescing elements where the oil is captured and drained through a drain line back into a lower pressure region - the inter-stage manifold. The nearly oil-free air passes through the minimum pressure valve, aftercooler, moisture separator, and finally to the distribution network.

LUBRICATION, COOLING AND SEALING (Figure 4-3, page 33) - Oil is forced by differential pressure from the oil reservoir through the oil cooler, thermostatic mixing valve/oil filter combination, distribution manifold, and enters the compressors and inter-stage manifold. A portion of the oil is directed to internal passages, on both 1st and 2nd stage airends, to lubricate the bearings and shaft oil seals. The balance of the oil is metered by solenoid valves and orifices and injected into the 1st stage compressor rotors and inter-stage manifold to remove the heat of compression, seal internal clearances and lubricate the rotors.

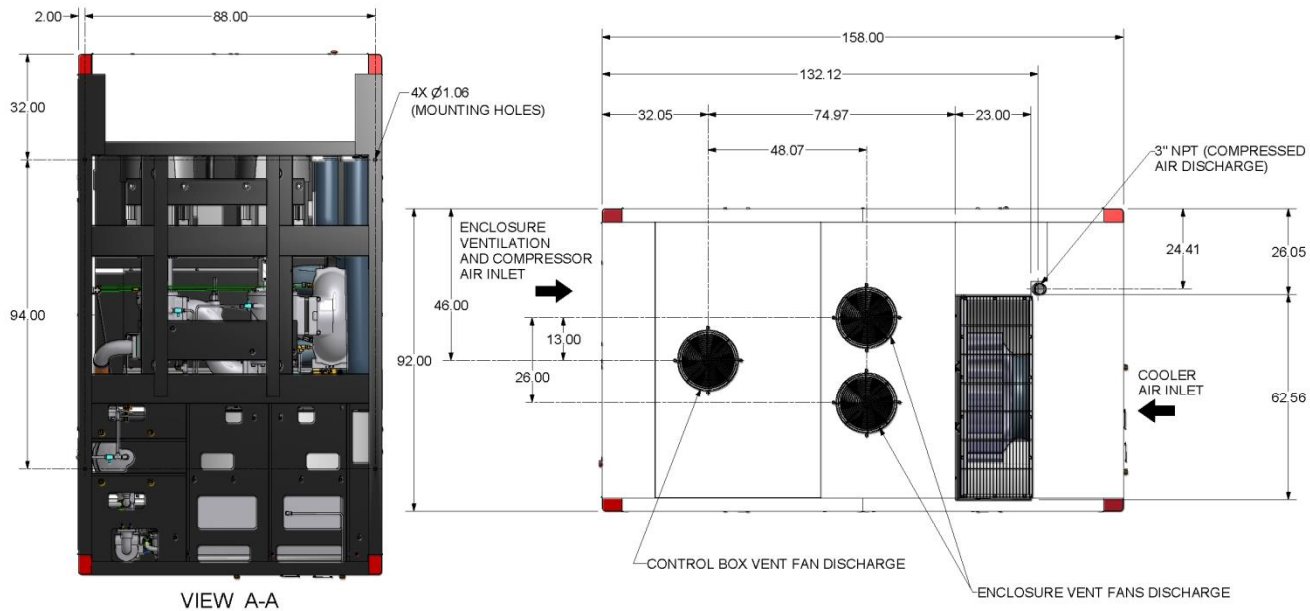

300VST804 - B
(Ref. Drawing)
Page 1 of 2

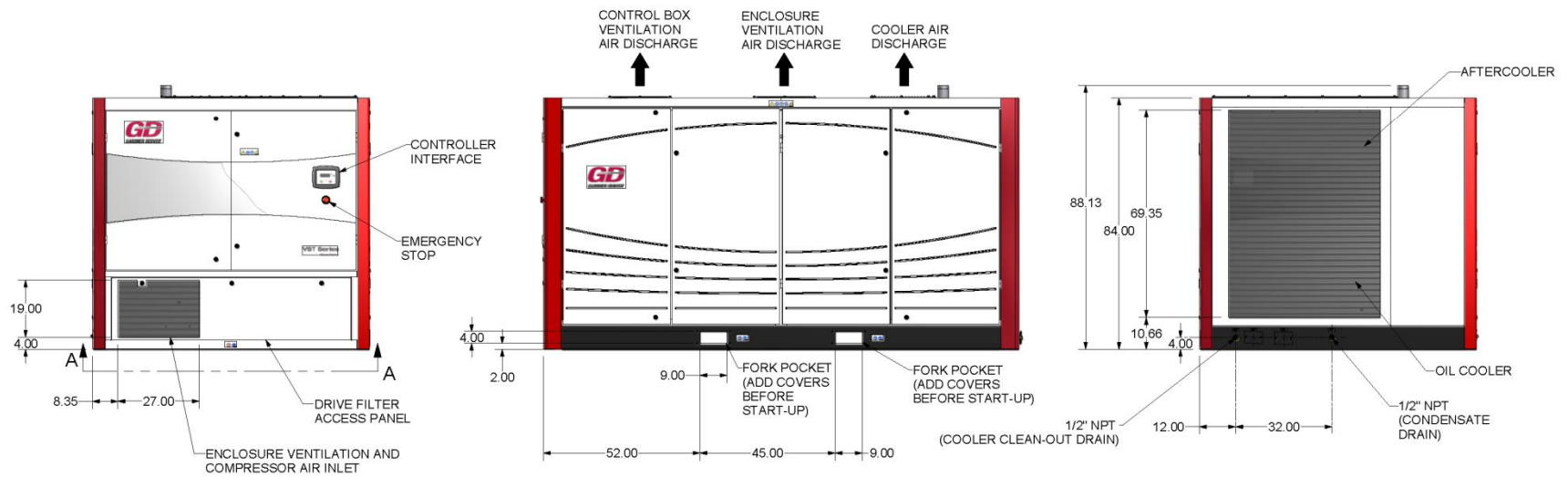
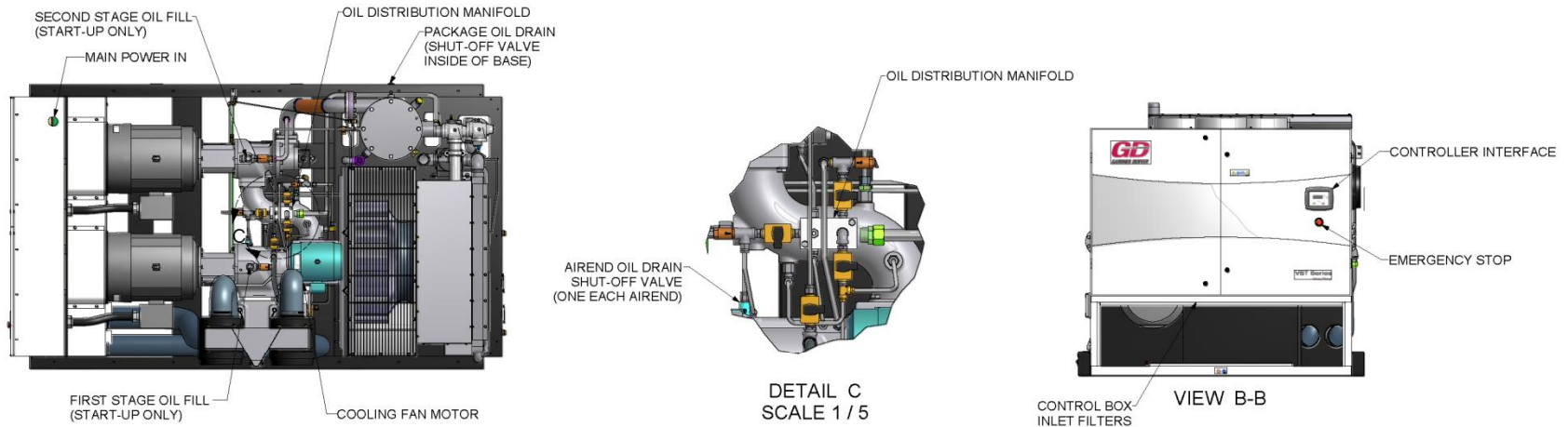
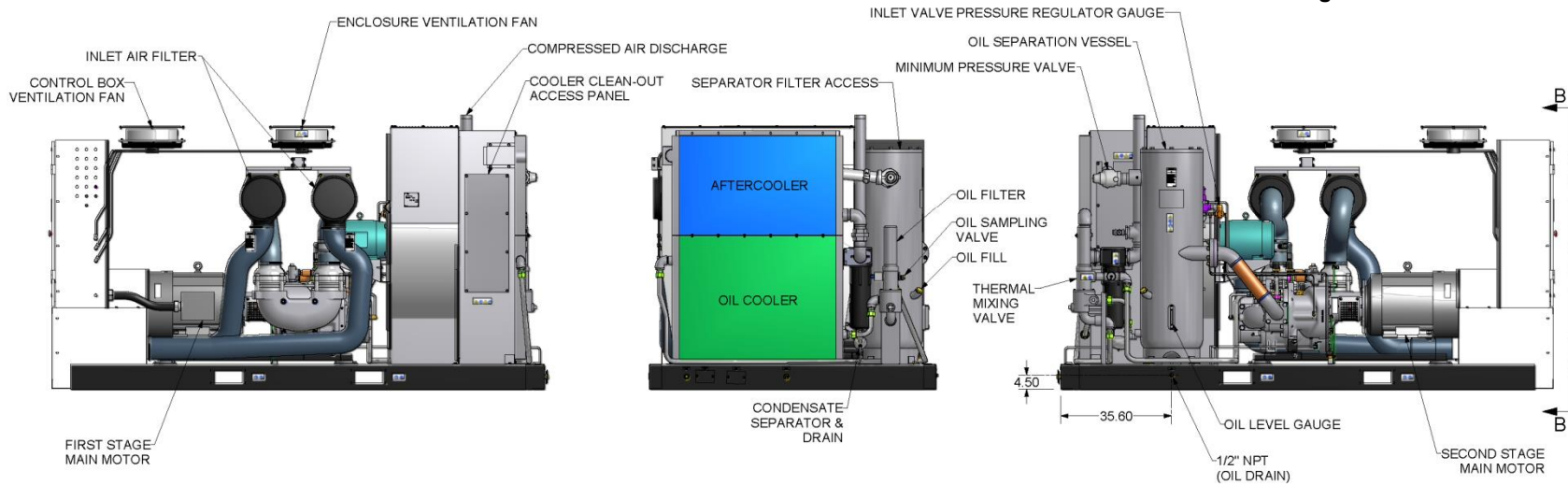

Figure 1-2 – PACKAGE ILLUSTRATION (AIR-COOLED) – External Details



300VST804-B (Ref. Drawing) Page 2 of 2



VIEWS SHOWN WITH ENCLOSURE REMOVED

Figure 1-3 – PACKAGE ILLUSTRATION (AIR-COOLED) – Internal Details

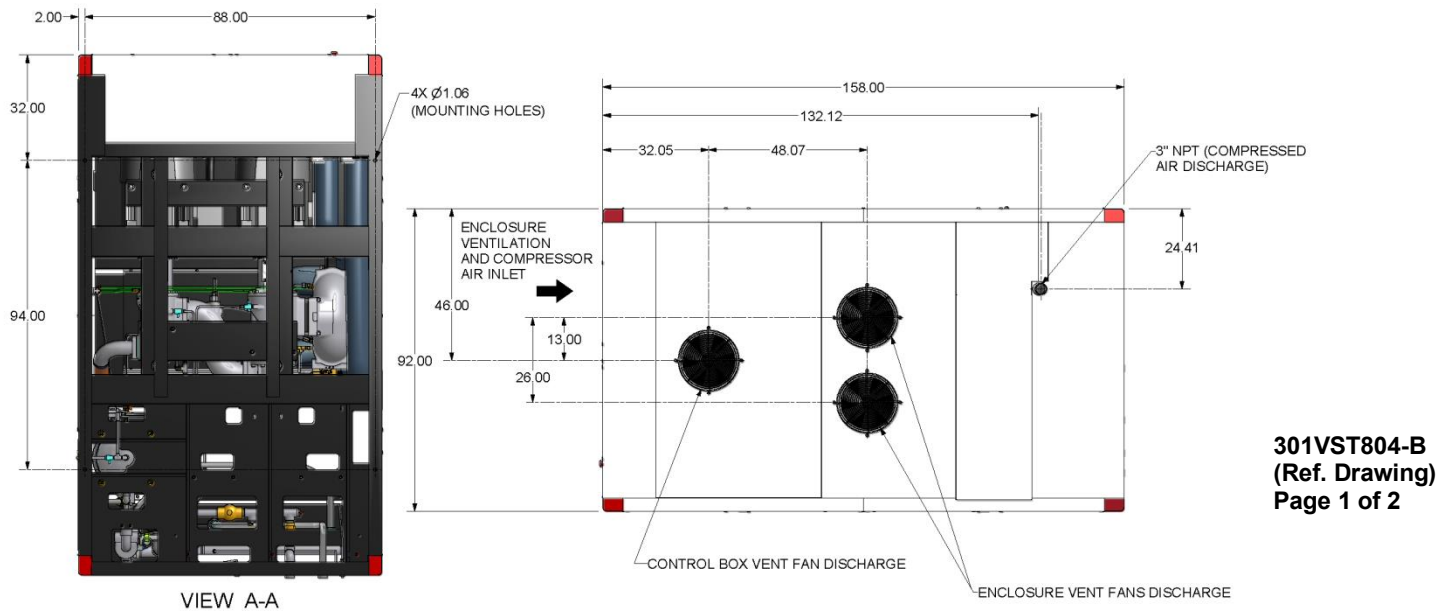

VIEW A-A

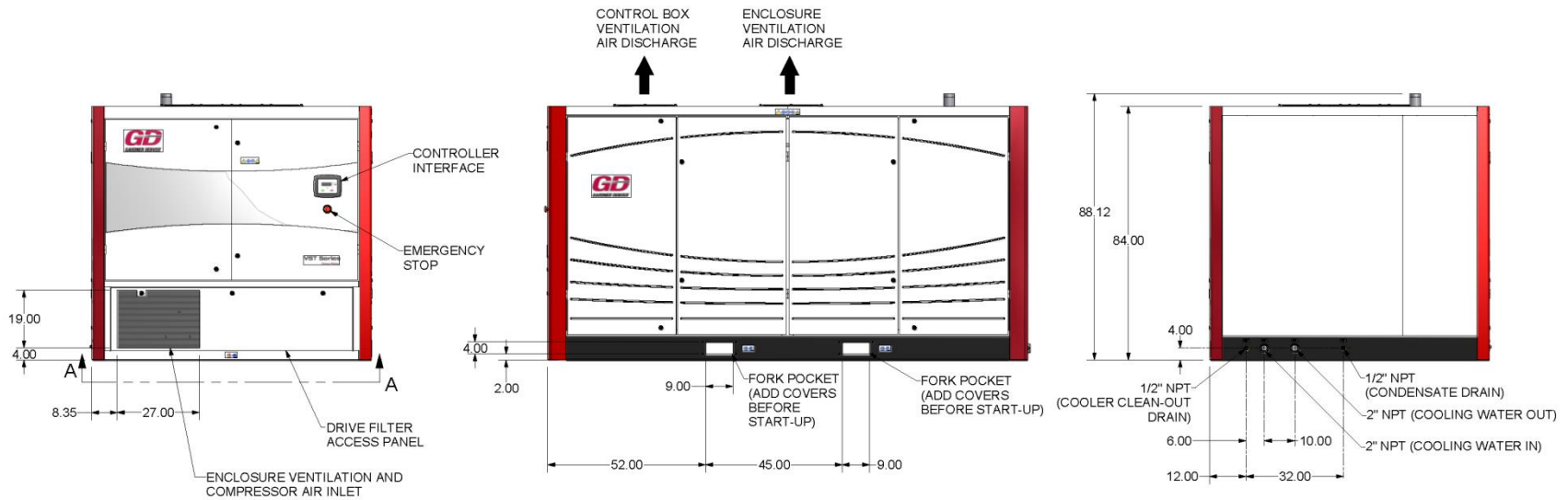
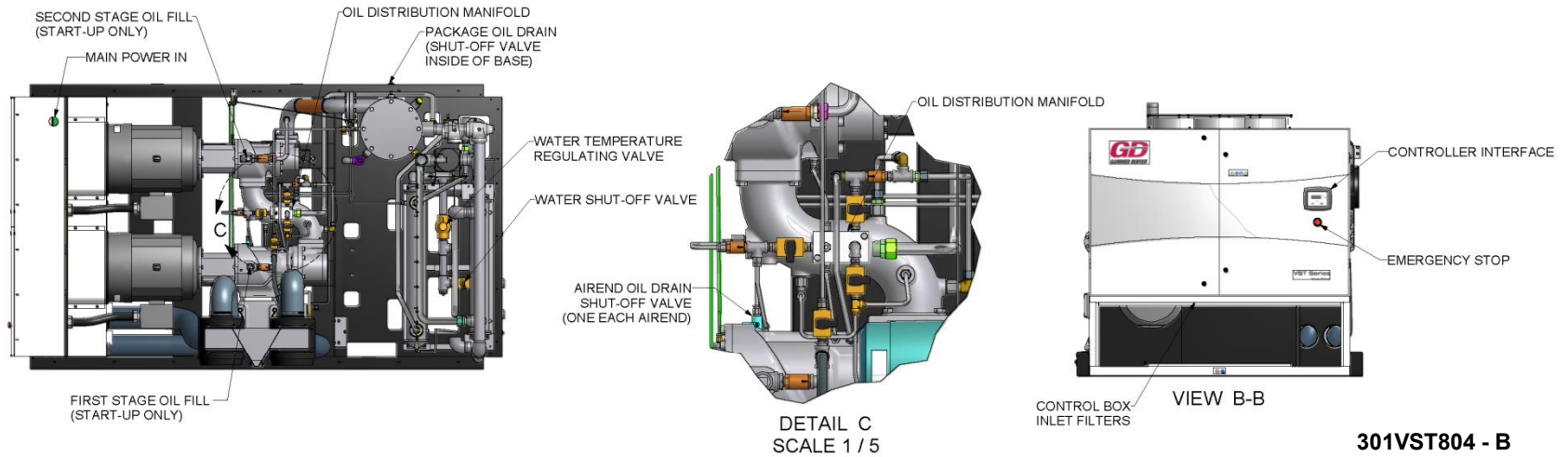
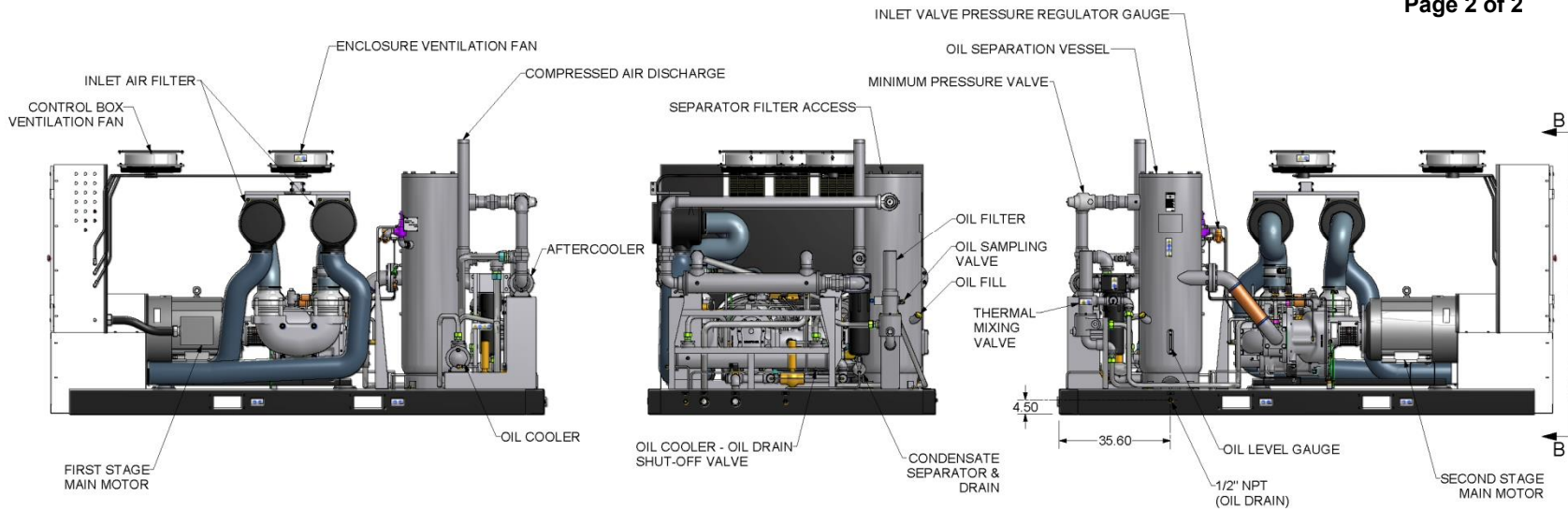

Figure 1-4 – PACKAGE ILLUSTRATION (WATER-COOLED) – External Details



301VST804 - B (Ref. Drawing) Page 2 of 2



VIEWS SHOWN WITH ENCLOSURE REMOVED

Figure 1-5 – PACKAGE ILLUSTRATION (WATER-COOLED) – Internal Details

SECTION 2 INSTALLATION

GENERAL - On receipt of the unit, check for any damage that may have been incurred during transit. Report any damage or missing parts as soon as possible.



Do not electric weld on the compressor or base; bearings can be damaged by passage of current.

LIFTING UNIT - Proper lifting and/or transporting methods must be used to prevent damage. Lifting slots are provided in the base for tow motor use. The unit may also be moved into location by rolling on bars.

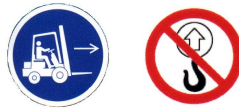

Lift compressor package by base only. Do not use other places such as motors, compressors or discharge manifold piping as lifting points.

The eyebolts or lugs provided on the motors are for lifting the motors only and should not be used to lift any additional weight. All eyebolts must be securely tightened. When lifting the motors, the lifting angle must not exceed 15 degrees. Failure to observe this warning may result in damage to equipment or personal injury.



Compressor, air/oil reservoir, separator chamber and all piping and tubing may be at high temperature during and after operation.

LOCATION - The compressor package shall be installed, whenever possible, in a clean, well-lighted, well-ventilated area with ample space all around for maintenance. Select a location that provides a cool, clean, dry source of air. In some cases it may be necessary to install duct work to reach a source of adequate cooling air, or to direct cooling air in and out of the compressor package to prevent re-circulation (e.g., not cooling the air entering the fresh air inlet). The package is designed to operate at ambient temperatures ranging from 40°F to 113°F (at up to 1000 meter elevation). Contact your local distributor for package operation at conditions exceeding the stipulated values.

A typical ventilation arrangement is shown in Figure 2-1.

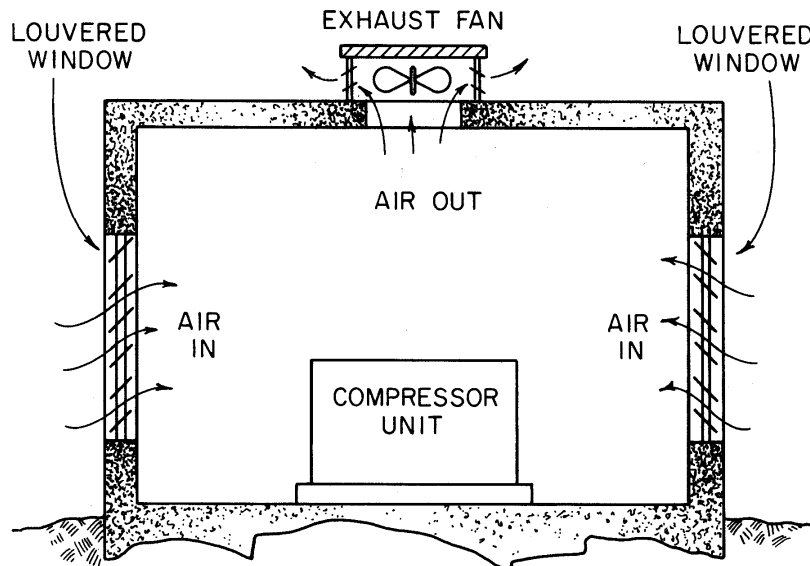

A75119

Figure 2-1 – TYPICAL COMPRESSOR ROOM

When selecting the compressor package location, be aware that its noise level may increase above its advertised free-field condition by reflections from nearby objects (e.g., walls, machinery, etc.) or by noise from nearby machinery.

Air-Cooled Units - A combination oil/air cooler is supplied as standard equipment on all air-cooled packages. The heat exchangers require sufficient cooling air flow to operate efficiently. Please refer to Section 6, Fig 6-1 of this manual for detailed instructions on the operation and maintenance of air-cooled heat exchangers, including minimum heat exchanger cooling and enclosure ventilation requirements.

Air for heat exchanger cooling is drawn in at the cooler end of the enclosure and is exhausted through a roof vent. Air for motor cooling, electronics cooling, and for the compressor intake is drawn in at the controller end and exhausted through three (3) roof vents. Refer to Package Illustrations on Figure 1-2 and Figure 1-3, pages 10 and 11, for hardware details.

Do not block flow of air entering or exiting the enclosure - allow 3-1/2 feet (1.1 m) clearance to the nearest obstruction all around and on top.

Water-Cooled Units . Separate shell-and-tube coolers for air and oil services are supplied on water-cooled packages. The heat exchangers require sufficient cooling water flow to operate efficiently . please refer to Section 6, page 52 of this manual for detailed instructions on the operation and maintenance of water-cooled heat exchangers, including minimum cooling water flow requirements.

Air for motor cooling, electronics cooling, and for the compressor intake is drawn in at the controller end and exhausted through three (3) roof vents . refer to Section 6, page 52 of this manual for enclosure ventilation requirements. Refer to Package Illustrations on Figure 1-4 and Figure 1-5, pages 12 and 13, for hardware details.

Do not block flow of air entering or exiting the enclosure - allow 3-1/2 feet (1.1 m) clearance to the nearest obstruction all around and on top.

FOUNDATION - The Gardner Denver Rotary Screw compressor requires no special foundation, but should be mounted on a smooth, solid surface and as near level as possible. Temporary installation may be made at a maximum 10° angle lengthwise or 10° sidewise.

Mounting bolts are not normally required. However, installation conditions such as piping rigidity, angle of tilt, or danger of shifting from outside vibration or moving vehicles may require the use of mounting bolts and shims to provide uniform support for the base.

OIL RESERVOIR DRAIN - The oil drain is piped from the bottom of the reservoir to the side of the base. This drain is approximately 4.50 inches (115 mm) above the floor level. If this is not sufficient to conveniently drain the oil, other methods are:

1. Elevate the compressor unit on a suitable structure to obtain the desired drain height.



If the compressor unit base is raised above floor level, the space between the floor and the base bottom must be closed with solid material all around to prevent main motor from running hot.

2. Construct an oil sump or trough below the floor level and pump or bail the drained oil.
3. Pump oil from the reservoir filler opening or drain to a container.

ENCLOSURE - The compressors, electric motors and oil/air cooler assembly are mounted inside the enclosure. Service doors are provided for maintenance access. Be sure to allow enough space around the unit for the doors to open completely.

To remove the enclosure doors, open the door and lift it up slightly to disengage the hinges.



Ducting may be required on air cooled enclosed machines.



Do not operate the compressors with the fan or coupling guard removed. Exposed fan and couplings may cause personal injury.

INSTALLATION FOR COLD WEATHER OPERATION - It is recommended that the unit be installed inside a shelter that will be heated to temperatures above freezing (40° F, 5° C). This will eliminate many of the problems associated with operating units in cold climates where freezing rain, drifting snow, freezing condensate and bitter cold temperatures are encountered.

Unsheltered (outside) installations should be avoided whenever possible. Installation next to a heated building where enough heat can be used to keep the compressor room above freezing will save many complications in the operation and installation of the unit.

Refer to Engineering Data Sheet 13-9-411, available from an authorized Gardner Denver distributor, for the advantages of using the heat recovered from rotary compressors. This heat recovery could easily pay for an adequate shelter for the unit.

AUXILIARY AIR RECEIVER - An auxiliary air receiver is not required if the piping system is large and provides sufficient storage capacity to prevent rapid cycling. An adequate receiver capacity for the VST units is 1/2 gallon for each cfm delivered by the compressor package.

MOISTURE SEPARATOR/TRAP - Since the unit is equipped with a built-in aftercooler, a combination moisture separator and drain valve are furnished with the unit.

CONTROL PIPING - Control piping is not necessary since the Gardner Denver compressor package is factory wired and piped for the control system specified.

INLET LINE - Where an inlet line is used between the air filters and the compressor, it must be thoroughly cleaned on the inside to prevent dirt or scale from entering the compressor. If welded construction is used, the line must be shot blasted and cleaned to remove welding scale. In either case, the inlet line must be coated internally by galvanizing or painting with a moisture and oil-proof sealing lacquer. Up to ten (10) feet (3 meters) in length, the inlet line should be the full size of the inlet opening on the compressor. If an extra-long line is necessary, the pipe size should be increased according to Inlet Line Length Chart Figure 2-2

Accessibility for inlet air filter servicing must be considered when relocating the filters from the unit to a remote location.

Length of Inlet Line	Diameter of Pipe Size
0 to 10 Feet (0 to 3 Meters)	Same as Compressor Inlet Opening
10 to 17 Feet (3 to 5 Meters)	One Size Larger Than Inlet Opening
17 to 38 Feet (5 to 11.5 Meters)	Two Sizes Larger Than Inlet Opening

Figure 2-2 – INLET LINE LENGTHS

DISCHARGE SERVICE LINE - The discharge service line connection on both water-cooled and air-cooled units is located at the center roof area of the enclosure. Gardner Denver compressor packages are inherently isolated from the service line by their own minimum pressure/check valves. Installer or end user must ensure that other compressors that are piped into a common pipe manifold with the Gardner Denver compressor package are each provided with an isolation check valve. It is recommended that an additional receiver be installed between the rotary screw and reciprocating compressors sharing a common pipeline. Do not install another check valve in the unit's discharge line as operational upsets will occur.



Discharge air used for breathing will cause severe injury or death.

Consult filtration specialists for additional filtration and treatment equipment to meet health and safety standards.

BLOW DOWN VALVE PIPING . The blow down valve is vented between the air filter and inlet valve, thus avoiding the need of any external pipe work.

WATER PIPING (Water-Cooled Heat Exchanger Models Only) - On machines equipped with water-cooled heat exchangers, the water inlet and outlet connections are located in the unit base flange.



It is mandatory that any water-cooled unit be installed in a shelter heated to temperatures above freezing (40° F., 5° C).

Please refer to Section 6, page 52 of this manual for detailed instructions on the installation, operation and maintenance of the water-cooled heat exchangers.

ELECTRICAL WIRING - The compressor package is (internally) factory wired for use with the voltage specified on the order - it is only necessary to connect power supply and ground wires to the provided wire blocks.



Electrical shock can cause injury or death. Open main disconnect switch, lockout and tagout before working on control box.

Gardner Denver Guidelines for proper wiring, grounding and feed power conditioning - This compressor package is provided with variable speed drives (VFDs) to control compressors and cooling fan motors. The indicated Gardner Denver guidelines for proper wiring, grounding, and feed power conditioning must be followed in order to protect the VFD electronics. Failure to do so will void your warranty.

Electrical Wire Sizing . A certified electrician familiar with National Electric Codes and applicable local codes shall size the electrical power wires serving the compressor package. Refer to Figure 2-3, for a summary of maximum package current consumption values.

460 VOLT VST110A VST150A and VST180A MINIMUM COPPER SUPPLY WIRE RECOMMENDATIONS

460 V					
VST-110 through VST 180					
Minimum Copper Supply Wire Recommendations					
Model	Minimum Supply Conductor Ampacity	Minimum 75°C Copper Wire Sized @ 30°C	Minimum 75°C Copper Wire Sized @ 40°C	Minimum 75°C Copper Wire Sized @ 45°C	Notes
VST 110	263	300 or 2/0 (2)	350 or 3/0 (2)	400 or 3/0 (2)	[1]
VST 150	358	4/0 (2)	250 (2)	300 (2)	[2]
VST 180	404	250 (2)	350 (2)	350 (2)	[2]

Notes: Wire sizes are per Table 310.15(B)(16) in the National Electrical Code (NEC)

- [1] 2/0 and 3/0 wires sized with derate for two parallel sets of conductors in a single conduit.
- [2] Wires sized with derate for two parallel sets of conductors in a single conduit.
- [3] Wires sized for 2 parallel sets of conductors in 2 conduits (1 set in each conduit).

The appropriate installation and use of 75°C wire is the responsibility of the electrical professional(s) performing the installation and must be per NEC, local and state regulations as allowed. All of the above recommended minimum wire sizes are based on all terminal connections being rated at 75°C minimum temperature rating and copper wire run lengths of 100 feet or less. Please note that all UL-508A listed control panels are rated for 40°C ambient conditions.

Figure 2-3 – PACKAGE MAXIMUM CURRENT CONSUMPTION SUMMARY

Electrical Wire Routing . Routing of the electrical power wires into the electrical hardware enclosure is best done through its roof area.

Line Reactor – A line reactor provides conditioning of the electrical power supply to the compressor package by attenuating noise and fluctuations. It shall be required in your particular application if any of the following conditions exist:

- Transformer KVA is greater than recommended . see Figure 2-4, page 20.
- Line has switched Power Factor correction capacitors.
- Existing line reactor not properly sized . see Figure 2-4, page 20
- Other large loads on the same power feed as the compressor.

GD Model	Volts	VFD HP RATINGS	Max KVA
VST110	400/480	2-100 HP / 10	1000
VST150	400/480	2-125 HP / 10	1000
VST180	400/480	2-125 HP / 10	1000

Figure 2-4 – LINE REACTOR SIZING RECOMMENDATIONS

GROUNDING – Equipment must be properly grounded in accordance with the National Electrical Code and/or applicable local codes.



Failure to properly ground the compressor package could result in injury or death. Install ground wiring in accordance with the National Electrical Code and any applicable local codes.

MOTOR LUBRICATION - Long time satisfactory operation of an electric motor depends in large measure on proper lubrication of the bearings. Refer to Section 13, page 72 of this manual for complete motor lubrication specifications and details.

SECTION 3 STARTING & OPERATING PROCEDURES

NOTICE



Read the Operator's Manual before operating the compressor.

PRESTART-UP INSTRUCTIONS - A new unit as received from the factory has been tested and then prepared for shipping only. **DO NOT** attempt to operate the unit until checked and serviced as follows:

1. **Compressor Oil** - Check the oil level in the reservoir . with unit stopped, sight gauge should be full or nearly so. Add oil, with unit stopped and depressurized, only if sight gauge does not show an oil level during steady, warm operation . typical level is middle of gauge under running conditions. Do not mix different type oils. When the unit is shipped, it is filled with Gardner Denver AEON[®] 9000TH lubricating coolant, suitable for the first 8000 hours under normal operating conditions.

Note that after compressor operation is stopped, the oil charge may partially drain back into the oil separation reservoir and register an abnormally high level at the sight glass. **DO NOT DRAIN OIL TO CORRECT**, as this condition will correct itself after resuming compressor operation.

NOTICE

Regular maintenance and replacement at required intervals of the oil filter, air filter and air/oil separator is necessary to achieve maximum service and extended drain intervals of AEON 9000TH synthetic lubricating coolant. Use only genuine Gardner Denver filters designed and specified for this compressor.

NOTICE

Whenever the oil is drained from either compressor (e.g., due to oil change or compressor replacement), a minimum amount must be replenished to lubricate and seal rotors during the start-up phase. Remove the provided oil fill plugs on the 1st and 2nd stage compressors and add 5.0 and 2.5 gallons, respectively.



Before removing the oil filler plug, always stop the unit and release air pressure, lockout and tagout the power supply to the compressor package. Failure to release pressure or properly disconnect the power may result in personal injury or death.

2. **Air Filter** - Inspect the air filters to be sure they are clean and the assemblies are sealed tight. Refer to Section 7, page 57 **Air Filter**, for complete servicing instructions. Be sure the inlet lines are clean and sealed tight.
3. **Couplings** - Check set screws for tightness. See Section 8, page 59.
4. **Piping** - Refer to Section 2, page 14 **Installation**, and make sure piping meets all recommendations.
5. **Electrical** - Check the wiring diagrams furnished with the unit to be sure it is properly wired. See Figure 4-4 thru Figure 4-11, pages 34 thru 41, for general wiring diagrams and Section 2, page 14 for installation instructions.
6. **Grounding** - Equipment must be properly grounded according to Gardner Denver Guidelines for proper wiring, grounding and feed power conditioning.



Failure to properly ground the compressor package could result in controller malfunction.

NOTICE



Read the Operator's Manual before operating the compressor.

7. **Rotation** - Check for correct rotation of all electric motors:
 - Use controller **LOG MODE** to bump compressor motors. Proper rotation (either stage) shall be counterclockwise when facing the compressor shaft end.
 - Use controller **LOG MODE** to bump heat exchanger cooling fan. Proper rotation shall be counterclockwise when facing rear of fan drive motor.
 - Use controller **LOG MODE** to bump enclosure (roof) ventilation fans. Proper rotation is achieved when ventilation air is discharged through each roof vent.



Operation with incorrect motor rotation can damage equipment and cause oil eruption from the compressor inlet. When checking motor rotation, induce minimum rotation (less than one revolution if possible). Never allow motor to reach full speed.



The compressor unit's direction of rotation must be checked every time the compressor is reconnected to the power supply.

- 8. **System Pressure** - Set the controls to the desired load pressure. DO NOT EXCEED THE MAXIMUM OPERATING PRESSURE ON THE COMPRESSOR NAMEPLATE.

Quick Start Guide

Operation of the AirSmart controller is easy. Simply select a Target Pressure and then press the Run  button to start the compressor, no other settings are required. The Target Pressure comes preset to 100 PSI from the factory. The Unload Pressure is preset to 110 PSI. If a different pressure setting is desired, the following steps can be used as a guide.

- **Setting the Target Pressure**

The Target Pressure setting is used to set the operating point of the compressor. To make any adjustments in the operation of the compressor, the machine must be stopped and in the Ready mode. Stop the compressor by pressing the Stop/Reset  button. The front panel display should read %READY+on line 3.

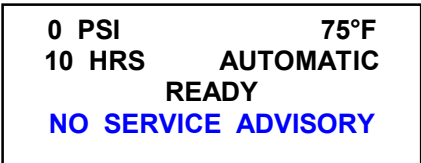

Next, press the Enter  button to access the Adjustment Menu tree

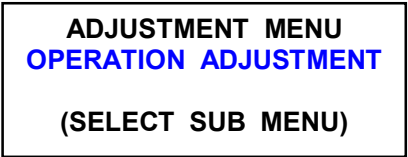

Since the Target Pressure setting is under the Operation Adjustment menu, press Enter  again to access that sub-menu

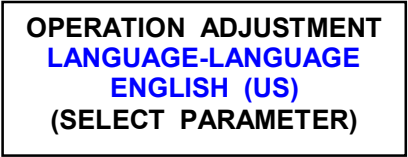







The Target Pressure is the second item in the Operation Adjustment sub-menu so press the Down  button to navigate to the Target Pressure setting.

OPERATION ADJUSTMENT
TARGET PRESSURE
100 PSI
(SELECT PARAMETER)

To change the Target Pressure, press the Enter  button to edit the value.

OPERATION ADJUSTMENT
TARGET PRESSURE
100 PSI
(EDIT PARAMETER)

A flashing cursor will appear covering the least significant digit in the Target Pressure value, use the Plus  and Minus  buttons to change its value. Use the Right  and Left  buttons to move the cursor to other digits in the Target Pressure value. When the desired Target Pressure value is displayed, press the Enter  button to save the new value. Pressing the Stop/Reset  button will abort the change and restore the previous value.

In order to save the changes made to parameters, press the Stop/Reset button to go back to the heading of the current menu and then press the Stop/Reset button again. If parameter changes have been made, the following screen will appear.

STORE MODIFIED
PARAMETERS?
STOP = NO
ENTER = YES

To permanently save the changes that were made, press the Enter  button. If the Stop/Reset button is pressed, the parameter changes will be lost the next time the compressor power is turned off.

Setting the Unload and Load Pressure

After setting the Target Pressure, set the Unload and Load Pressures values in a similar fashion. The Unload pressure is the third item in the Operation Adjustment sub-menu so press the Down  button to navigate to the Unload Pressure setting. The Unload Pressure will control at which pressure the compressor unload and stops.

OPERATION ADJUSTMENT
UNLOAD PRESSURE
110 PSI
(SELECT PARAMETER)

The Load pressure is the fourth item in the Operation Adjustment sub-menu so press the Down  button to navigate to the Load Pressure setting. The Load Pressure will control at which pressure the compressor will startup again after unloading.

OPERATION ADJUSTMENT
LOAD PRESSURE
100 PSI
(SELECT PARAMETER)



Operation at excessive discharge air pressure can cause personal injury or damage to equipment. Do not adjust the full discharge air pressure above the maximum stamped on the unit nameplate.

9. **Operating Mode** - Refer to Section 4, page 28 and Controller Manual 13-17-600 for detailed information on the control system.
10. **Enclosure** - Check for damaged panels or doors. Check all screws and latches for tightness. Be sure doors are closed and latched.

STARTING THE UNIT - Observe the following starting procedures.

Unit Cold - If the unit is fitted with water-cooled heat exchangers, fully open water inlet valve(s). If the unit is located in a cold environment (e.g., ambient temperature below 40°F, 5 °C), the required external heat source must be energized prior to start. Press the red %STOP/RESET+ button to clear any conditions (e.g., %Loss of Power+when electrical system was energized) and start the unit by pushing the green %START+ button. Since the unit is equipped with a minimum pressure valve (80 psig, 5.5 bar), no special procedure to maintain minimum reservoir pressure is required.

Unit Hot - Start-up instructions are the same as that of a cold start.

DAILY CHECK - Refer to Section 14, page 73 Maintenance Schedule+.

STOPPING THE UNIT - Press %STOP-RESET+button. The oil reservoir will automatically blow down, as the motors are de-energized. Be sure external heat is turned on if below 40 °F (5°C),



Automatic restarting or electrical shock can cause injury or death. Disconnect, lockout and tagout the unit from the power supply and any other circuits before servicing unit.



When the pressure relief valve opens, a stream of high velocity air is released, resulting in a high noise level and possible discharge of accumulated dirt or other debris. Always wear eye and ear protection and stand clear of the discharge port when testing the pressure relief valve to prevent injury.



Never paint, lubricate or alter a pressure relief valve. Do not plug vent or restrict discharge.

 **DANGER**



Operation of the unit with improper pressure relief valve setting can result in severe personal injury or machine damage. Ensure properly set valves are installed and maintained.

SECTION 4 CONTROLS & INSTRUMENTATION

GENERAL DESCRIPTION - The Gardner Denver rotary screw compressor package is pre-wired with all electrical components suitable for the voltage and horsepower at time of order. It is necessary only to connect the compressor unit to the correct power supply and to the shop air supply network - and to the appropriate water supply if using the water-cooled variant. A standard two-stage compressor package consists of two sets of compressors, motors and VFDs with common oil separation/reservoir, oil cooling/filtering/distribution system, air cooling/filtering system, IP54 electrical enclosure to house VFDs and common controller and a sound-attenuating enclosure. The various control devices employed are described as follows:

Controller - The compressor package features the AirSmart controller, which integrates all the control functions under microprocessor control. Controller functions include safety and shutdown, compressor regulation, operator control and advisory/maintenance indicators. The keypad and display provide the operator with a logical and easily operated control of the compressor and indication of its condition. The controller is factory adjusted for the compressor package, but allows tuning for specific applications.

NOTICE



Read the Operator's Manual before operating the compressor. It is critical that the detailed instructions for the controller, found in the controller manual 13-17-600, are read and understood. Once the appropriate parameters have been selected into the controller, compressor operation may commence.

Press the red %STOP/RESET+button to clear any conditions (e.g., %Loss of Power+when electrical system was energized) and start the unit by pushing the green %START+button. Since the unit is equipped with a minimum pressure (80 psig, 5.5 bar) valve, no special procedure to maintain minimum reservoir pressure is required.

Main VFD and Motors . Each compressor is driven by an inverter-duty electric motor, which in turn is energized by a pulse-width modulated, variable frequency drive (commonly referred to as VFD). This combination of components enables the compressor package to match the supply of compressed air (e.g., flow capacity) to meet the customer's demand in real time and in a step-less fashion. The operational logic which governs each drive and motor-combination is supplied by the AirSmart controller and it is based on the following basic rules:

- The speed of the 1st stage compressor is modulated (e.g., increased or decreased) until the desired system discharge pressure is achieved.
- The speed of the 2nd stage compressor is modulated until its power consumption equals that of the 1st stage.

The drives share a common IP54 protected enclosure with the AirSmart controller and assorted electrical hardware. Ventilation for the electronics is supplied by a combination of dual intake air filters and dual discharge air filters with electric fans. The motors are built with TEFC protected frames and coupled to each compressor via a NEMA-D flange. Each drive includes adequate current overload protection for its companion motor.

The drives and motors are designed to operate with 3ph-60Hz-460Vac electrical powers, which must be installed in accordance with local (site) Electrical Code requirements.

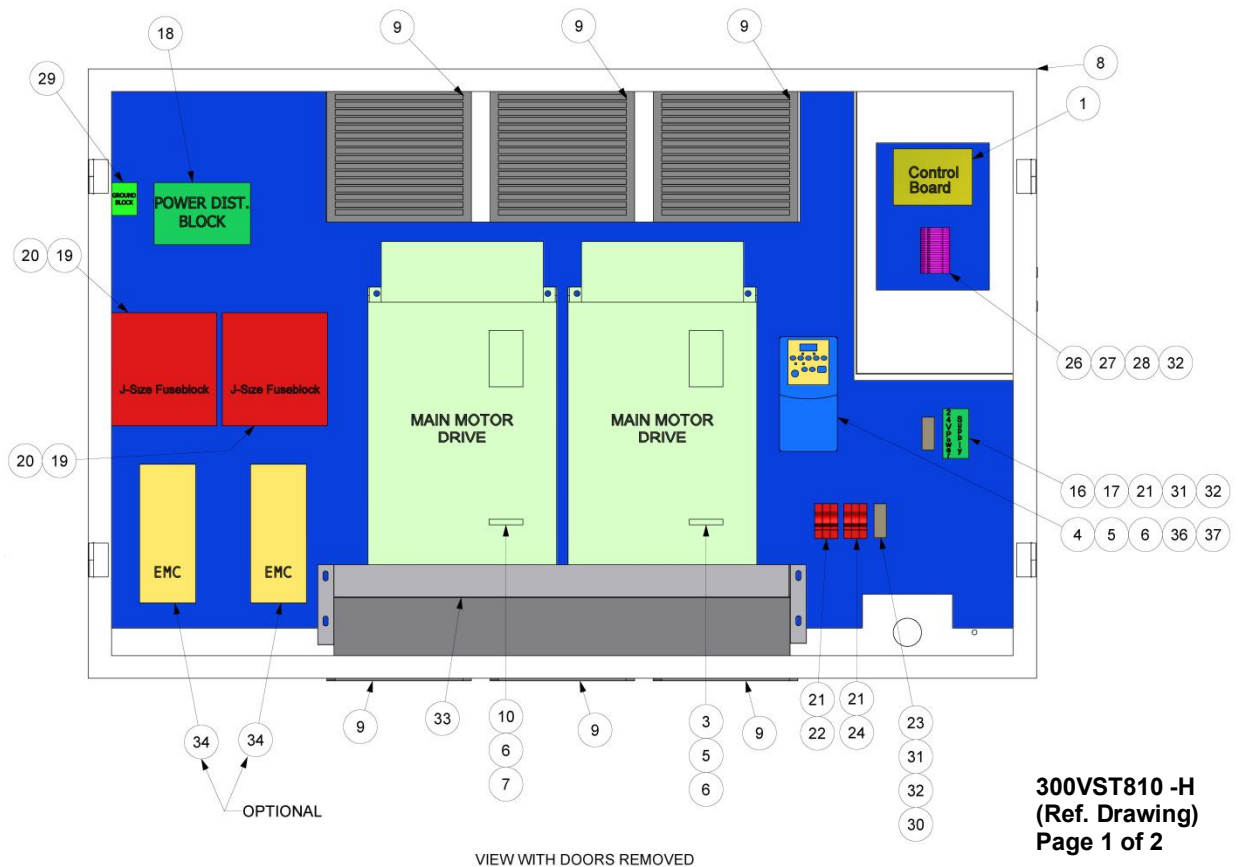

Item	Description	Item	Description
1	Control Assembly	21	Fuse Holder
3	Variable Frequency Drive	22	Fuse
4	Variable Frequency Drive (Air-Cooled only)	23	Starter
5	Cable	24	Fuse
6	Splitter	25	Overload Relay
7	Resistor	26	Terminal Block
8	Control Box	27	Terminal Block
9	Filter	28	Terminal Block
10	Fan/Filter	29	Terminal Block
13	Control Transformer	30	Terminal Block
14	Fuse	31	Terminal Block
15	Fuse	32	Terminal Block
16	Power Supply	33	Baffle
17	Din Rail Kit	34	EMC Filter (Optional)
18	Power Distribution Block	37	Screw Terminal Plug
19	Fuse Holder	36	Wire
20	Fuse	38	Variable Frequency Drive

Figure 4-1 – ELECTRICAL ENCLOSURE HARDWARE

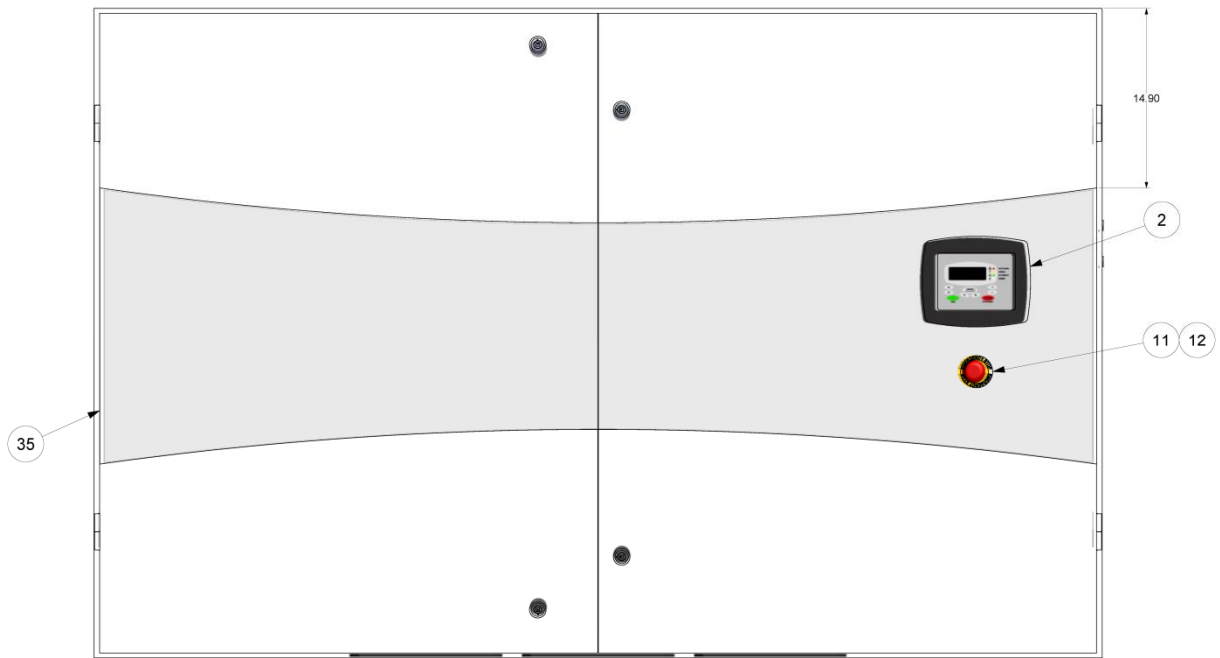

**300VST810 -H
(Ref. Drawing)
Page 2 of 2**

Item	Description
2	Key Pad
11	Emergency Stop Operator
12	Contact Block
35	Decal

Figure 4-2 – ELECTRICAL ENCLOSURE HARDWARE

Fan VFD and Motors - The radial fan providing cooling air for the heat exchangers is driven by an inverter-duty (TEFC) electric motor, which in turn is energized by a pulse-width modulated, variable frequency drive (commonly referred to as VFD). This combination of components enables the controller to match the heat exchanger coolant needs in proportion with load level (e.g., flow capacity) of the compressor package, thus saving fan power. The AirSmart controller supplies the operational logic, which governs the fan drive and motor combination and it is based on proportioning the fan speed to that of the 1st stage compressor.

The drive includes adequate current overload protection for its companion motor, and is designed to operate with 3ph-60Hz-460vac electrical power . the necessary electrical wiring has been provided.

Ventilation Fan Motors and Starter . Combination fan/motors exhausts hot air build-up from the package enclosure and the electrical enclosure. The starter provides control and overload protection for all three (3) ventilation fan/motor. Overload heaters should be selected and adjusted based on the aggregate motor nameplate amps and the instructions located inside the cover of the electrical box. These devices are designed to operate with 3 ph-60 Hz-460 vac electrical power . the necessary electrical wiring has been provided.

Control Transformer - This device reduces the incoming power voltage to 110-120 volts for use by various control components (e.g., 24 Vdc power supply, electrical enclosure cooling fans, etc.). Two primary fuses and one secondary fuse are provided for overload protection.

Power Supply (24Vdc) - This device supplies electrical power to the AirSmart controller and various solenoid valves.

For Letter References A thru AA below, see Figure 4-3, page33.

Inlet (Poppet) Valve (B) . This device is located at the intake flange of the compressor. During compressor operation, the underside of the poppet is vented to atmosphere via a 3-way solenoid valve, allowing the poppet to fall (open) and feed fresh air to the compressor inlet. During stopped operation modes (e.g. command from keypad or initiated by protective shutdown), the 3-way solenoid valve feeds an air signal to the underside of the poppet, forcing it upward (close) and block off the compressor intake. This prevents trapped air and oil within the compressor from exiting through the inlet filter. See SECTION 10 for further details.

Minimum Discharge Pressure/Check Valve (G) – This device maintains a minimum pressure within the air/oil reservoir, thus insuring (cooling/lubricating) oil injection flow into the compressors. It also serves as a check valve to prevent back flow of compressed air from the customer's piping back into the compressor package when it is not active.

The spring-loaded piston does not allow the discharge of compressed air from the air/oil reservoir until the compressor builds up pressure beyond 80 psig. Beyond this pressure level, the valve remains fully open.

Oil Mixing Valve (L) . This device, which is located at the inlet side of the oil cooler, mixes cooled and hot oil prior to delivery to the oil filter and oil injection manifold. It helps maintain a minimum oil temperature of approximately 140°F at low load levels or low ambient temperature conditions.

Pressure Relief Valve (O) . This device protects the pressure containing components of the compressor package against high pressure exceeding 200 psig.

Check Valve – Inter-stage Pressure (P) . This device protects the 1st stage compressor and the inter-stage piping from high pressure caused by the accidental stoppage of the 2nd stage compressor. A build-up of inter-stage pressure is safely vented through the check valve, to the air/oil reservoir.

Pressure Regulator (Q) . This device supplies the air pressure signal to actuate the inlet control valve. The regulator is provided with a pressure gauge and is typically set to 80 psig.

Inlet Feed Valve (C) - This (three-way solenoid) device supplies/vents the required pneumatic signal to actuate the poppet valve. When energized, it vents the air signal from the inlet poppet valve, allowing it to open and when de-energized, it supplies the air signal to the inlet poppet valve, forcing it closed. Note that this pilot operated valve requires 37 to 40 psig pressure, at its intake port, to achieve its normally open position (de-energized).

Oil Flow Control Valves (U) - These devices feed a regulated amount of oil into various areas of the 1st stage compressor and inter-stage manifold, in order to maintain optimal 1st and 2nd stage compressor discharge temperatures (between 195°F and 220°F). See Section 5, page 42 **Lubrication System**, for detailed information on their operation.

Check Valve – Auxiliary Purge (V) - This device supplies air to 1st stage compressor during **empty system** startup.

Ball Valve – Oil Drain (W) - This device allows the drainage of oil entrapped within the compressors, interstage pipe, and oil separation vessel during oil change operation.

Check Valve – Oil Flow Control (X) - This devices prevent the reversal of oil flow from the higher pressure into lower pressure regions of the oil system.

Air Filter Vacuum Switch (Y) - This device measures the vacuum pressure at the discharge side of the inlet air filter. When air filter vacuum reaches 30 inches of water, it triggers the controller to advise the user that the filter requires service or replacement.

Blow Down Valve (S) - This (two-way solenoid) device vents compressed air from the air/oil reservoir. During compressor operation (e.g., compressors are running or they have temporarily stopped due to line pressure reaching unload pressure), the blow down valve remains energized (closed) and the air/oil reservoir remains pressurized. When compressor operation is halted (e.g., by use of the red **STOP** controller button, by loss of electrical energy, or by a shutdown condition), the valve is de-energized (normally open state) and the air/oil reservoir is blown down

FEATURES:

- > INLET CONTROL VALVE INTRODUCES MINIMAL FLOW LOSSES.
- > SUPPORTS FOLLOWING MODES OF OPERATION:
 - >> FULL LOAD OPERATION WITH CAPACITY MODULATION (100% TO 20%) VIA SPEED VARIATION.
 - >> STOPPED OPERATION.
- > MAINTAINS OPTIMAL AIR-TO-OIL MASSFLOW RATIO WITHIN 100% TO 20% CAPACITY MODULATION.
- > BEARING LUBRICATION BY PRESSURE GRADIENT.
- > MAIN OIL INJECTION FLOW CONTROL BY DISCRETE STEPS.

LEGEND:

- AIR
- - - INJECTION OIL
- BEARING OIL
- - - WATER
- WATER CONDENSATE

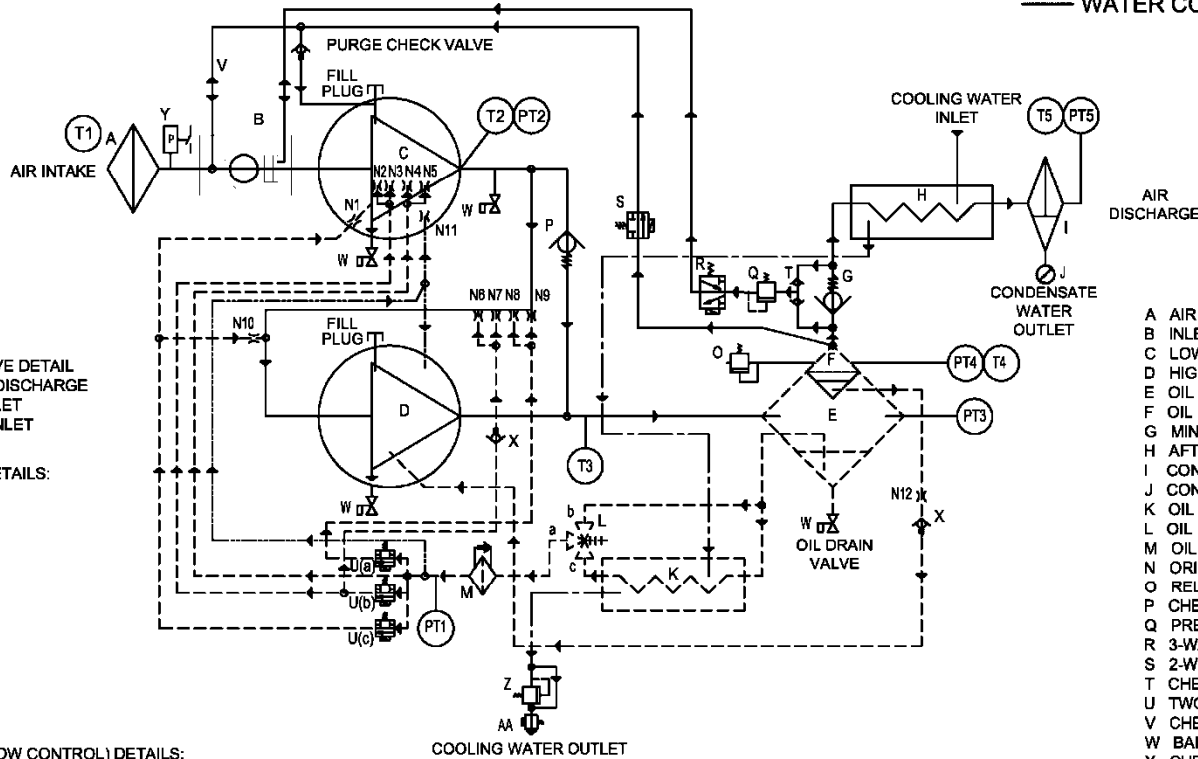

- A AIR FILTER
- B INLET CONTROL VALVE
- C LOW PRESSURE COMPRESSOR
- D HIGH PRESSURE COMPRESSOR
- E OIL SEPARATION VESSEL
- F OIL COALESCER(S)
- G MINIMUM PRESSURE VALVE
- H AFTERCOOLER
- I CONDENSATE SEPARATOR
- J CONDENSATE DRAIN DEVICE
- K OIL COOLER
- L OIL MIXING VALVE
- M OIL FILTER
- N ORIFICE (N1-N12)
- O RELIEF VALVE - HIGH PRESSURE
- P CHECK VALVE - INTERSTAGE PRESSURE
- Q PRESSURE REGULATOR - INLET VALVE FEED
- R 3-WAY SOLENOID VALVE - INLET VALVE FEED
- S 2-WAY SOLENOID VALVE - BLOWDOWN
- T CHECK VALVE SHUTTLE
- U TWO-WAY SOLENOID VALVE - OIL FLOW CONTROL
- V CHECK VALVE - AUXILIARY PURGE
- W BALL VALVE - OIL DRAIN
- X CHECK VALVE - OIL FLOW CONTROL
- Y VACUUM SWITCH
- Z THERMOSTATIC FLOW REGULATOR
- AA FLOW STOP SOLENOID VALVE

OIL MIXING VALVE DETAIL
 (d) = MIXED OIL DISCHARGE
 (e) = HOT OIL INLET
 (f) = COOL OIL INLET

ORIFICE SIZE DETAILS:

- N1 - .276 DIA.
- N2 - .173 DIA
- N3 - .173 DIA
- N4 - .098 DIA
- N5 - .098 DIA
- N6 - 1/2 HH50W
- N7 - 1/2 HH50W
- N8 - 3/8 HH24W
- N9 - 3/8 HH24W
- N10 - 3/4 - 6W
- N11 - .098 DIA
- N12 - .035 DIA

ORIFICE (OIL FLOW CONTROL) DETAILS:

- N1 TO N5: INTERNAL ORIFICES MACHINED INTO AIR END CASTINGS
- N6 TO N9: EXTERNALLY PIPED NOZZLE ASSEMBLIES
- N10 TO N11: EXTERNALLY PIPED ORIFICES
- N12: OIL SCAVENGE EXTERNAL ORIFICE

2-WAY SOLENOID (OIL FLOW CONTROL) DETAILS

- MIN. POWER CONDITION: U(a), U(b), U(c) CLOSED
- LOW POWER CONDITION: U(a) OPEN
- MED. POWER CONDITION: U(b) OPEN
- HIGH POWER CONDITION: U(a), U(b) OPEN
- START-UP AND MAX POWER CONDITIONS: U(a), U(b), U(c) OPEN

- PT1 = OIL PRESSURE TRANSDUCER
- PT2 = INTERSTAGE PRESSURE TRANSDUCER
- PT3 = RESERVOIR PRESSURE TRANSDUCER
- PT4 = SEPARATOR PRESSURE TRANSDUCER
- PT5 = PLANT PRESSURE TRANSDUCER
- T1 = AMBIENT TEMPERATURE THERMISTOR
- T2 = INTERSTAGE TEMPERATURE THERMISTOR
- T3 = RESERVOIR TEMPERATURE THERMISTOR
- T4 = SEPARATOR TEMPERATURE THERMISTOR
- T5 = PLANT TEMPERATURE THERMISTOR

300VST797-B
 (Ref. Drawing)

Figure 4-3 – PIPING AND INSTRUMENTATION ILLUSTRATION

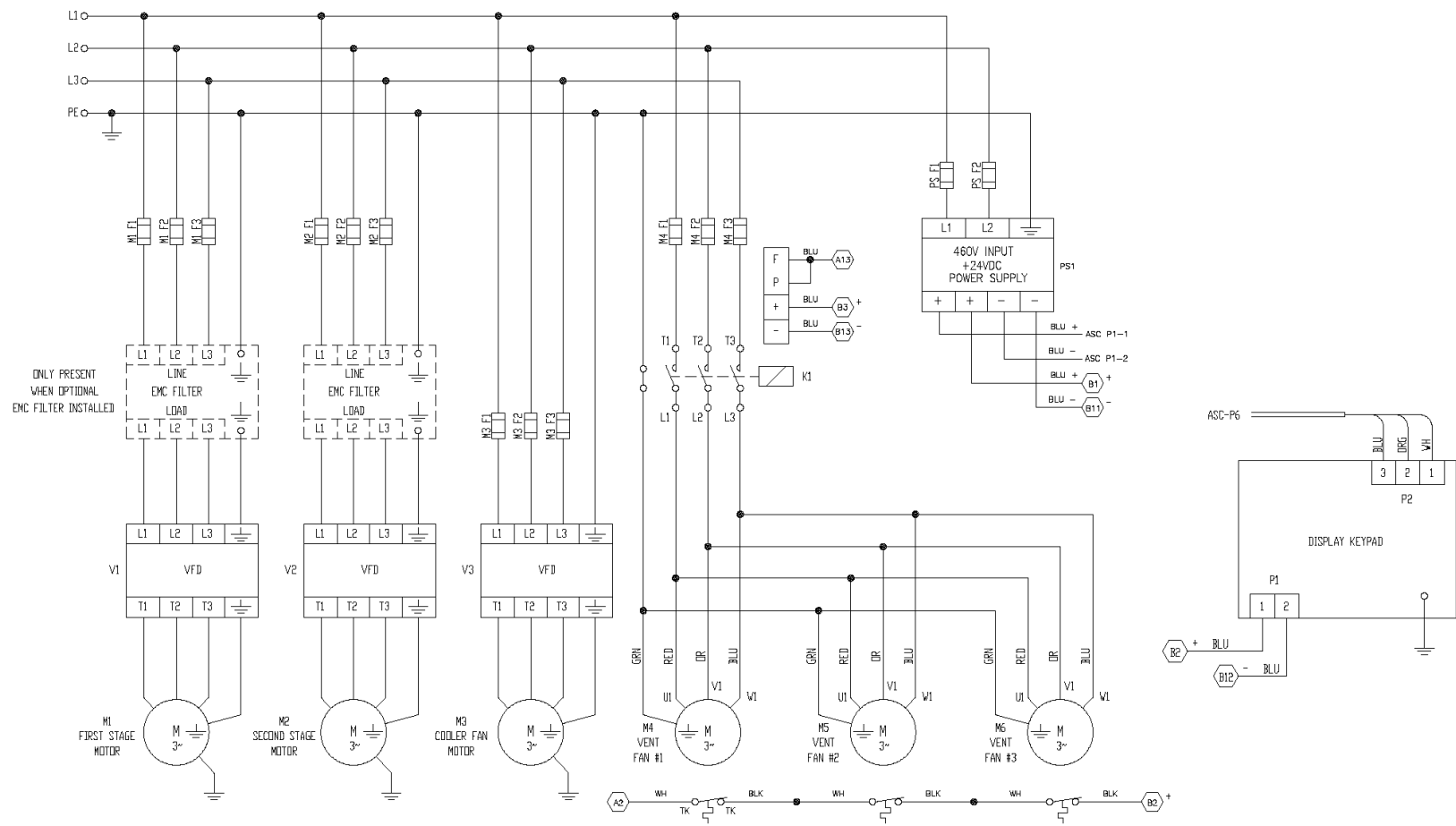

Figure 4-4 – WIRING DIAGRAM – (AIR-COOLED) Two-Stage VS Control

300VST546-C
(Ref. Drawing)
Page 1 of 4

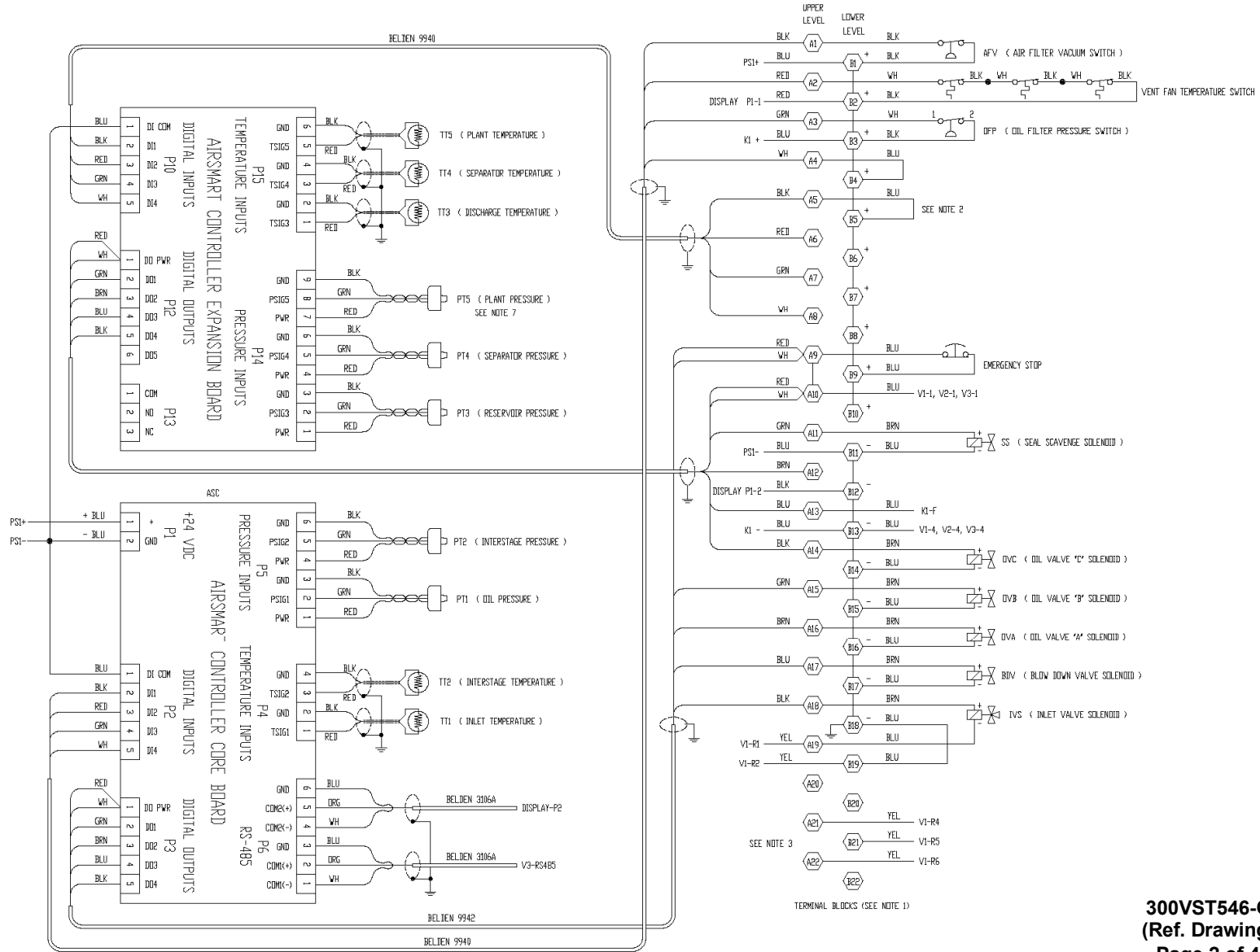

Figure 4-5 – WIRING DIAGRAM – (AIR-COOLED) Two-Stage VS Control

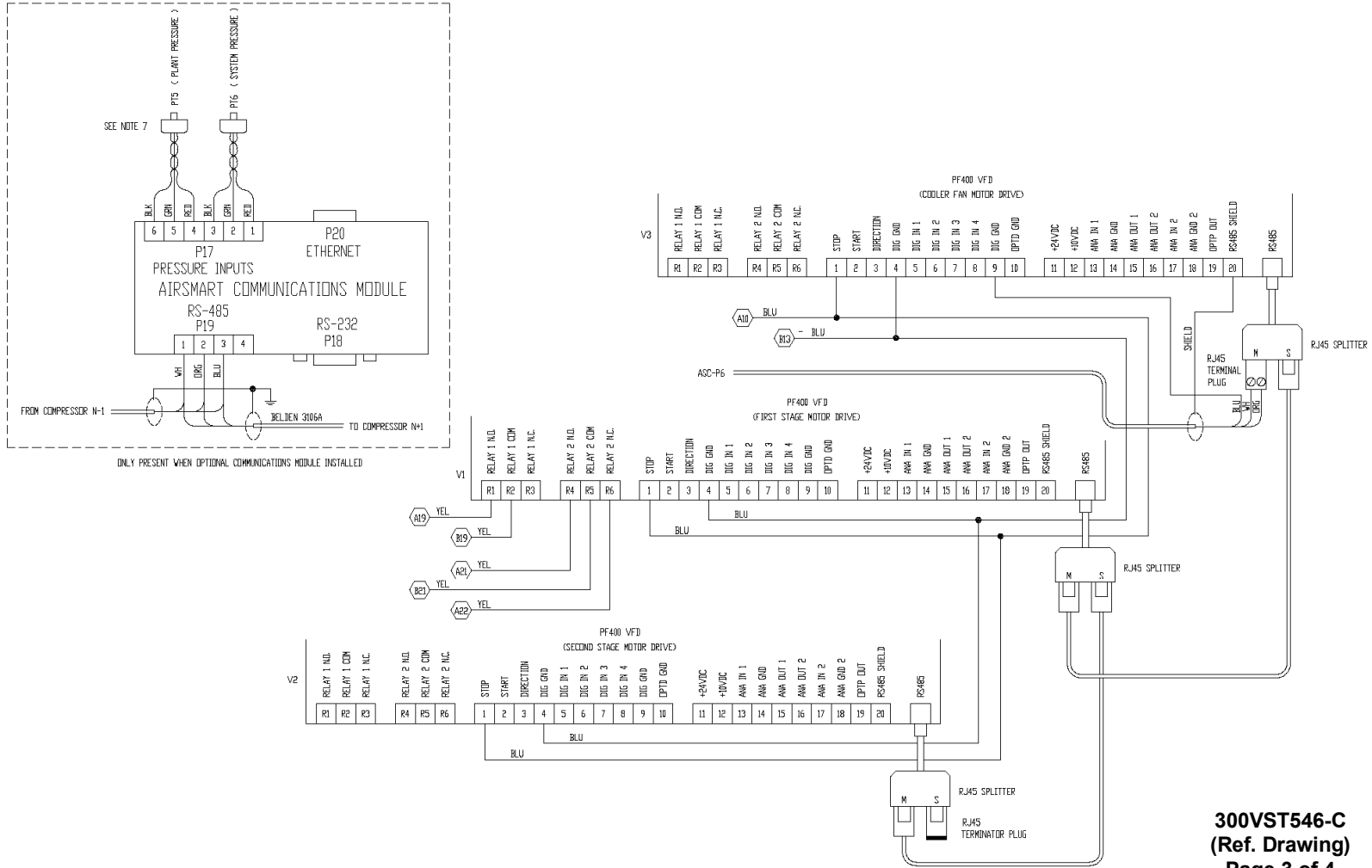
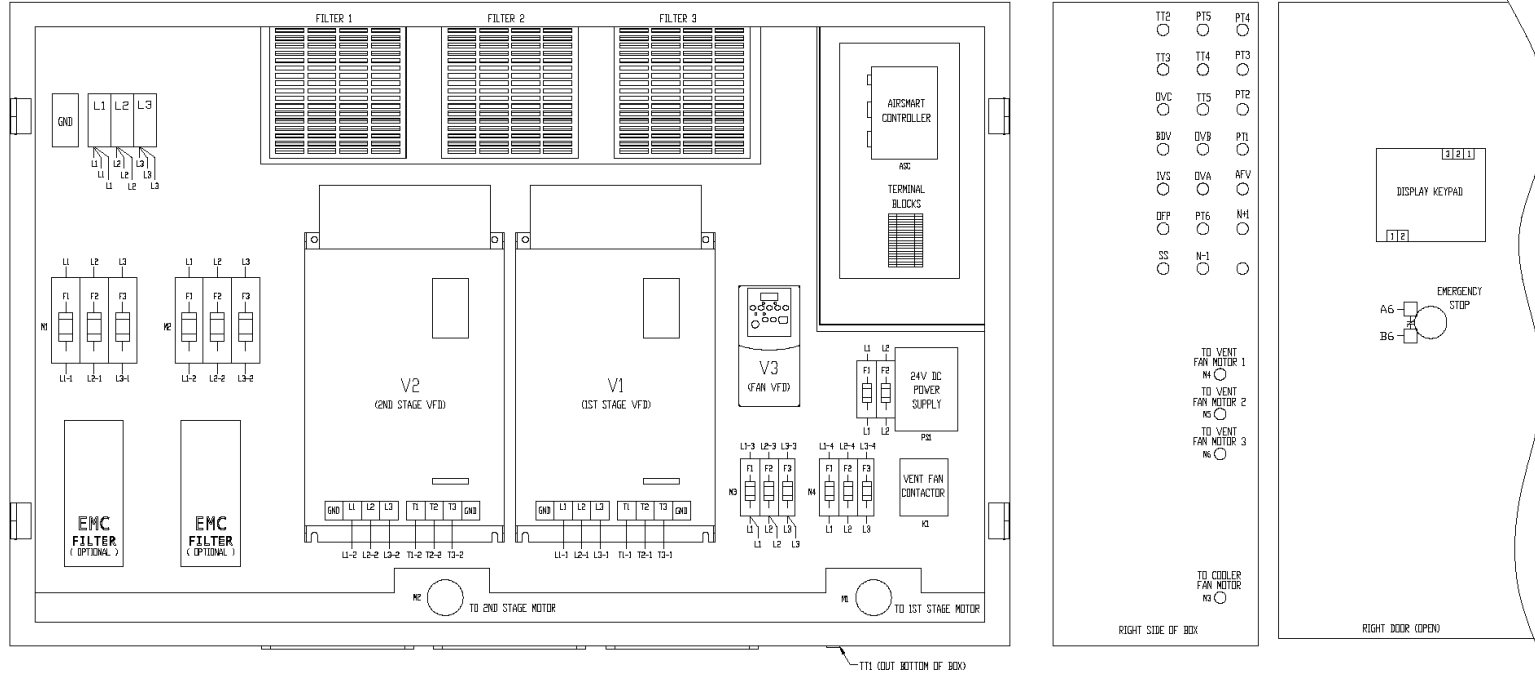

Figure 4-6 – WIRING DIAGRAM – (AIR-COOLED) Two-Stage VS Control

300VST546-C
 (Ref. Drawing)
 Page 3 of 4



NOTES:

- SHORTING JUMPERS INSTALLED ON TERMINALS BLOCKS AS FOLLOWS
+24VDC - B1, B2, B3, B4, B5, B6, B7, B8
DC GND - B9, B10, B11, B12, B13, B14, B15, B16
E-STOP QUALIFIED +24VDC - A6, A7
- FOR CONTROL BY REMOTE CONTACT, REMOVE JUMPER BETWEEN TERMINALS A5 AND B5 AND CONNECT N.C. SWITCH
- ADVISORY/SHUTDOWN ALARM CONTACT BETWEEN A19 AND B19 (N.D.), A20 AND B19 (N.C.). - CONTACT RATING: N.D., 3A @ 30VDC, 3A @ 240VAC
- THE MAIN BACK PLATE MUST BE BONDED TO CONTROL BOX USING 4 AWG (MIN) BONDING STRAP.
- THE CONTROLLER BACK PLATE MUST BE BONDED TO MAIN BACK PLATE USING 4 AWG (MIN) BONDING STRAP.
- THE CONTROL BOX DOORS MUST BE BONDED TO CONTROL BOX USING 10 AWG (MIN) BONDING STRAP.
- WHEN COMMUNICATIONS MODULE IS INSTALLED AND PT6 IS INSTALLED, CONNECT PT5 TO P17, PINS 4-6.

LEGEND

- P11 = OIL PRESSURE TRANSDUCER
- PT2 = INTERSTAGE PRESSURE TRANSDUCER
- PT3 = RESERVOIR PRESSURE TRANSDUCER
- PT4 = SEPARATOR PRESSURE TRANSDUCER
- PT5 = PLANT PRESSURE TRANSDUCER
- PT6 = SYSTEM PRESSURE TRANSDUCER
- TT1 = INLET TEMPERATURE THERMISTOR
- TT2 = INTERSTAGE TEMPERATURE THERMISTOR
- TT3 = RESERVOIR TEMPERATURE THERMISTOR
- TT4 = SEPARATOR TEMPERATURE THERMISTOR
- TT5 = PLANT TEMPERATURE THERMISTOR
- IVS = INLET VALVE SOLENOID
- BDV = BLOW DOWN VALVE SOLENOID
- AFV = AIR FILTER VACUUM SWITCH
- ASC = AIRSMART CONTROLLER
- K1 = VENT FAN CONTACTOR
- DVA = OIL FLOW SOLENOID VALVE A
- DVB = OIL FLOW SOLENOID VALVE B
- DVC = OIL FLOW SOLENOID VALVE C
- DFP = OIL FILTER PRESSURE SWITCH

- V1 = VARIABLE FREQUENCY DRIVE FIRST STAGE
- V2 = VARIABLE FREQUENCY DRIVE SECOND STAGE
- V3 = VARIABLE FREQUENCY DRIVE FAN MOTOR
- M1 = FIRST STAGE MOTOR
- M2 = SECOND STAGE MOTOR
- M3 = COOLER FAN MOTOR
- M4 = ENCLOSURE VENT FAN MOTOR
- M5 = ENCLOSURE VENT FAN MOTOR
- M6 = ENCLOSURE VENT FAN MOTOR
- PS1 = 24V DC POWER SUPPLY
- N-1 = PREVIOUS SEQUENCED COMPRESSOR
- N+1 = NEXT SEQUENCED COMPRESSOR
- SS = SEAL SCAVENGE SOLENOID

300VST546-C
(Ref. Drawing)
Page 4 of 4

Figure 4-7 – WIRING DIAGRAM – (AIR-COOLED) Two-Stage VS Control

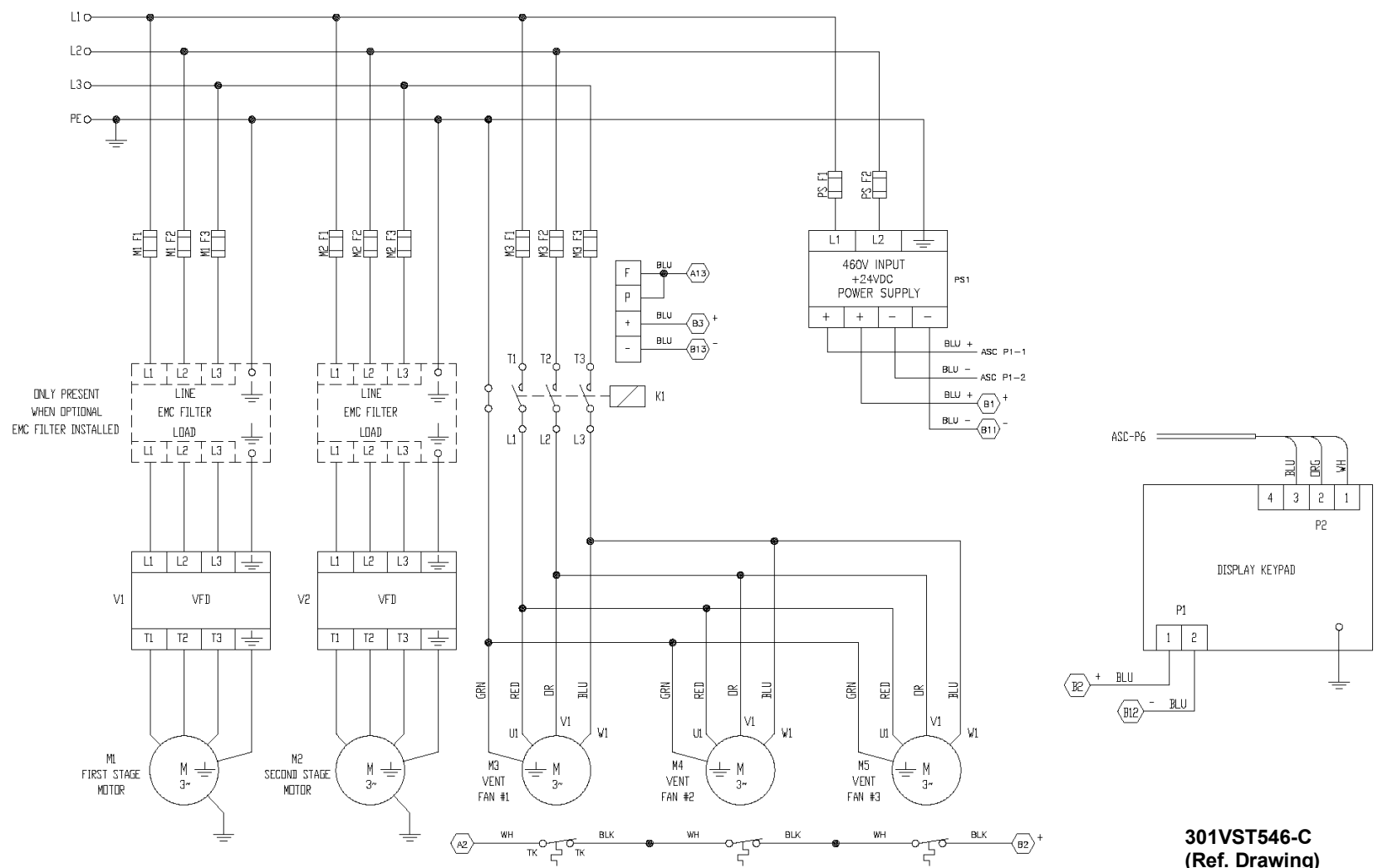

Figure 4-8 – WIRING DIAGRAM – (WATER-COOLED) Two-Stage VS Control

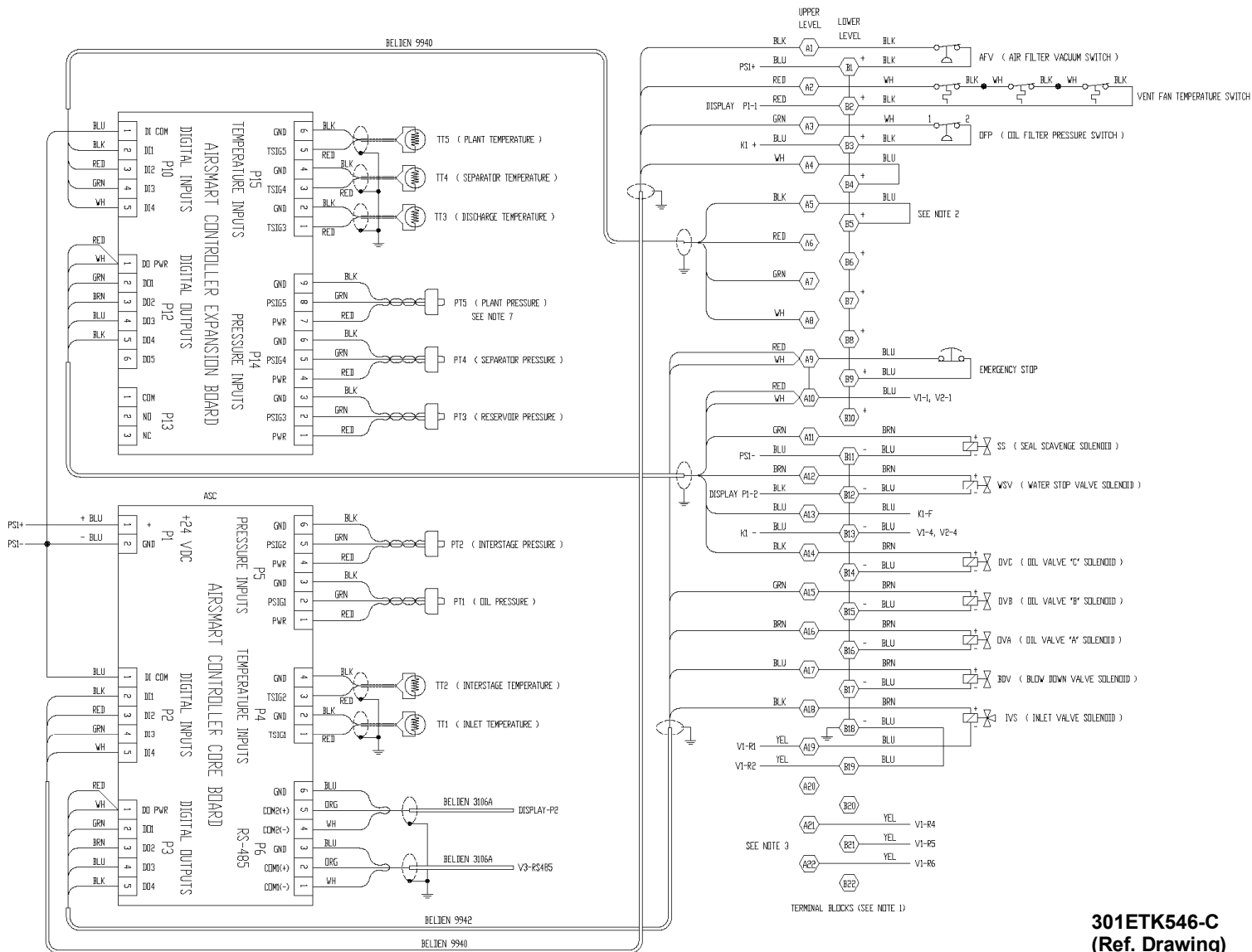
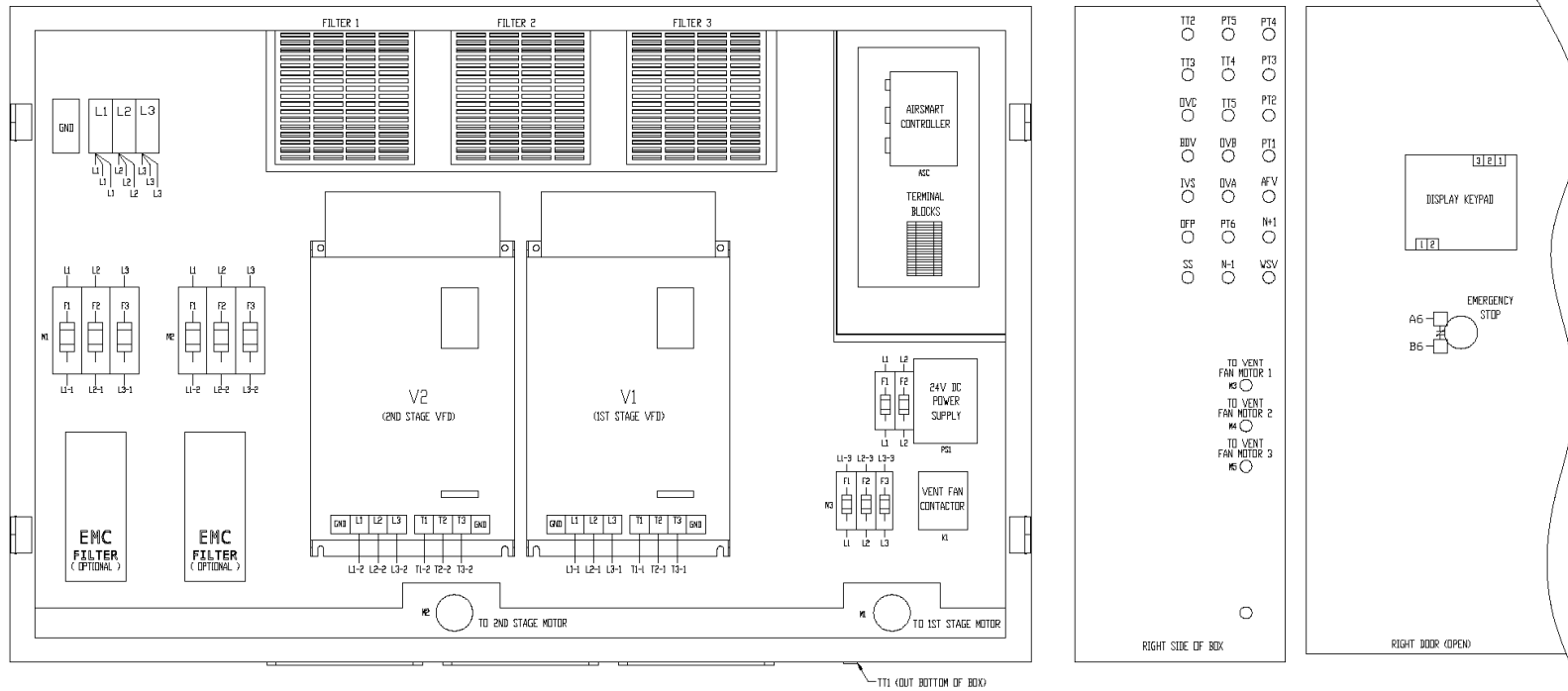

Figure 4-9 – WIRING DIAGRAM – (WATER-COOLED) Two-Stage VS Control



NOTES:

- SHORTING JUMPERS INSTALLED ON TERMINALS BLOCKS AS FOLLOWS
 +24VDC - B1, B2, B3, B4, B5, B6, B7, B8
 DC GND - B9, B10, B11, B12, B13, B14, B15, B16
 E-STOP QUALIFIED +24VDC - A6, A7
- FDR CONTROL BY REMOTE CONTACT, REMOVE JUMPER BETWEEN TERMINALS A5 AND B5 AND CONNECT N.C. SWITCH
- ADVISORY/SHUTDOWN ALARM CONTACT BETWEEN A19 AND B19 (N.O.), A20 AND B19 (N.C.). - CONTACT RATING: N.O. 3A @ 30VDC, 3A @ 240VAC
- THE MAIN BACK PLATE MUST BE BONDED TO CONTROL BOX USING 4 AWG (MIN) BONDING STRAP.
- THE CONTROLLER BACK PLATE MUST BE BONDED TO MAIN BACK PLATE USING 4 AWG (MIN) BONDING STRAP.
- THE CONTROL BOX DOORS MUST BE BONDED TO CONTROL BOX USING 10 AWG (MIN) BONDING STRAP.
- WHEN COMMUNICATIONS MODULE IS INSTALLED AND PT6 IS INSTALLED, CONNECT PT5 TO P17, PINS 4-6.

LEGEND

- PT1 = OIL PRESSURE TRANSDUCER
- PT2 = INTERSTAGE PRESSURE TRANSDUCER
- PT3 = RESERVOIR PRESSURE TRANSDUCER
- PT4 = SEPARATOR PRESSURE TRANSDUCER
- PT5 = PLANT PRESSURE TRANSDUCER
- PT6 = SYSTEM PRESSURE TRANSDUCER
- TT1 = INLET TEMPERATURE THERMISTOR
- TT2 = INTERSTAGE TEMPERATURE THERMISTOR
- TT3 = RESERVOIR TEMPERATURE THERMISTOR
- TT4 = SEPARATOR TEMPERATURE THERMISTOR
- TT5 = PLANT TEMPERATURE THERMISTOR
- IVS = INLET VALVE SOLENOID
- BDV = BLOW DOWN VALVE SOLENOID
- AFV = AIR FILTER VACUUM SWITCH
- ASC = AIRSMART CONTROLLER
- K1 = VENT FAN CONTACTOR
- OVA = OIL FLOW SOLENOID VALVE A
- OVB = OIL FLOW SOLENOID VALVE B
- OVC = OIL FLOW SOLENOID VALVE C
- OFP = OIL FILTER PRESSURE SWITCH

- V1 = VARIABLE FREQUENCY DRIVE FIRST STAGE
- V2 = VARIABLE FREQUENCY DRIVE SECOND STAGE
- M1 = FIRST STAGE MOTOR
- M2 = SECOND STAGE MOTOR
- M3 = ENCLOSURE VENT FAN MOTOR
- M4 = ENCLOSURE VENT FAN MOTOR
- M5 = ENCLOSURE VENT FAN MOTOR
- PS1 = 24V DC POWER SUPPLY
- N-1 = PREVIOUS SEQUENCED COMPRESSOR
- N+1 = NEXT SEQUENCED COMPRESSOR
- WSV = WATER STOP VALVE SOLENOID
- SS = SEAL SCAVENGE SOLENOID

301VST546-C
 (Ref. Drawing)
 Page 4 of 4

Figure 4-11 – WIRING DIAGRAM – (WATER-COOLED) Two-Stage VS Control

SECTION 5 COMPRESSOR LUBRICATION – SEPARATION, FILTRATION AND CONTROLS

 **DANGER**



Air/oil under pressure will cause severe personal injury or death. Shut down compressor, relieve system of all pressure, disconnect, lockout and tagout power supply to the compressor package before removing valves, caps, plugs, fittings, bolts and filters.

 **CAUTION**

High temperature operation can cause damage to equipment or personal injury. Do not restart the unit repeatedly after high temperature shutdown. Find and correct the malfunction before resuming operation.

COMPRESSOR OIL SYSTEM . Lubricating oil is employed to absorb the heat of compression, lubricate moving parts and seal internal clearances between the rotor and air cylinder. Pressure differential between the air/oil reservoir and various injection points is used to flow oil through the package.

Oil exits the air/oil reservoir and is then routed to the heat exchanger and the thermal mixing valve, where cold (oil cooler branch) and hot (bypass branch) are mixed to the desired (140°F) temperature. Tempered oil is sent to the oil filter for cleaning, then onto various points in the 1st stage compressor and inter-stage pipe manifold through various solenoid valves and orifices. The injected oil absorbs heat from compression while progressing through the compression chamber and is then discharged back into the oil separation chamber as a mixture of liquids and aerosols (oil) and gas (air).

Centrifugal action within the air/oil reservoir separates the bulk of the oil from the air, where it is collected and readied for the next cooling cycle. The compressed air and aerosols continue through a coalescing filter, where all but 2 ppm of oil is removed from the compressed air and discharged to the aftercooler.

RECOMMENDED LUBRICANT . The Gardner Denver compressor is factory-filled with AEON 9000TH lubricant. This lubricant is formulated to the highest quality standards and is factory-authorized, tested and approved for use in our rotary screw compressors. AEON 9000TH lubricant is available through your authorized Gardner Denver compressor distributor.

OIL SPECIFICATIONS - The factory fill compressor lubricant is Gardner Denver AEON 9000TH lubricating coolant for all-year-round operation. This is a polyol ester (POE) synthetic lubricant specially formulated for high operating temperatures (210°F to 225°F), which can extend change intervals up to 4 times that of a petroleum based lubricant.

It is highly recommended that the lubricating oil be analyzed frequently in order to identify its quality and remaining operational life. A sampling valve, located on the tubing between the oil filter and the injection manifold, is provided for this purpose.

 **CAUTION**

Use of improper lubricants will cause damage to equipment. Do not mix different types of lubricants or use inferior lubricants.

 **CAUTION**

All materials used in Gardner Denver compressor units are compatible with AEON 9000TH Synthetic Lubricating Coolant. Use caution when selecting downstream components such as lubricating bowls, gaskets and valve trim.

AEON 9000TH Synthetic Lubricating Coolant is not compatible with Nitrile (Buna N) or acrylic paints. AEON 9000TH is compatible with most air system downstream components.

Safety Data Sheets (SDS) are available for all AEON 9000TH lubricants from your authorized Gardner Denver distributor or by calling 800-682-9868.

MOISTURE IN THE OIL SYSTEM - The oil injection system provided with your compressor package has been designed to avoid water vapor condensation during all modes of operation (e.g., load level, ambient temperature or relative humidity and discharge pressure). It achieves this goal by maintaining a final discharge temperature between 195°F and 220°F. Refer to Figure 5-4, page49, for the dew point trends of the compressed air at four typical pressure levels.

This feature does not eliminate the need to analyze the lubricating oil frequently. If an analysis reveals the presence of water in the oil, it may indicate that the oil injection system is malfunctioning. Contact your authorized Gardner Denver factory distributor for assistance.

OIL SIGHT GLASS - This device indicates oil level within the air/oil reservoir . See Figure 5-1 for details.

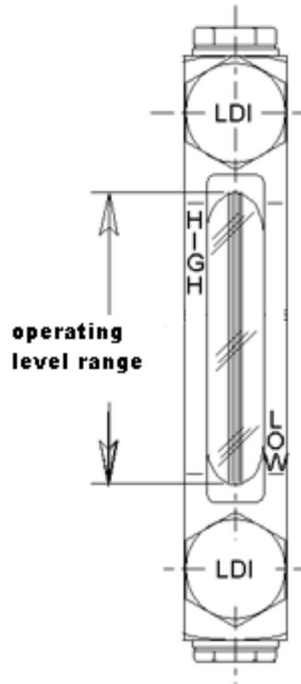

Figure 5-1 – OIL LEVEL SIGHT GLASS

To ensure best performance from the oil separation system, adhere to the following guidelines:

- Before starting the unit, make sure that oil level is visible in the sight gauge. An oil level of at least ½ the sight gauge height will ensure there is enough oil to safely operate the compressor.
- During unit operation, and after a steady compressor discharge temperature is reached, check the oil level:
 - Add oil only when the level is below the LOW mark on sight glass. This will make the refill intervals less frequent. Note that each inch of oil level represents 2.0 gal. of oil.
 - Drain oil only when the level is above the HIGH mark on sight glass. Be aware that a stopped unit, when filled to its maximum oil capacity (approximately 25 gallons), may show a full sight glass . this is normal and does not require oil drainage.
 - The oil level in the sight glass will fluctuate as the compressor load changes, as a function of the air/oil volume ratio within the compressor pipe works. Refer to Figure 5-1 for typical operational oil levels attained at various compressor load levels and with a full charge of oil:

Controller Display Load Level - %	Oil Sight Glass level with full oil charge - inches	Oil Sight Glass lowest acceptable level - in
100	4.0	2.0
80	3.5	1.5
60	3.0	1.0
40	2.5	.5
20	2.0	.0

Figure 5-2 – LOAD VS SIGHT GLASS OIL LEVEL CHANGE

ADDITION OF OIL BETWEEN CHANGES . Oil losses (typically 2 ppm) from the oil separation system may require replenishment between scheduled changes. If (during operation only) the sight glass shows no oil or lowest acceptable level shown in Figure 5-1, add oil per the following steps:

1. Be sure the unit is completely off and that no air pressure is in the oil reservoir.
2. Disconnect lockout and tagout the power supply to the compressor package.
3. Wipe away all dirt around the oil filler plug
4. Remove the oil filler plug and add (or drain if correcting high level) sufficient oil to adjust its level to nearly the top of the sight glass.
5. Install the oil filler plug, open the isolation valve (when provided), restore power and run the unit to check for leaks and proper oil level. If incorrect oil level is indicated, repeat steps 1 through 5.

Note that after compressor operation is stopped, the oil charge may partially drain back into the oil separation reservoir and register an abnormally high level at the sight glass. **DO NOT DRAIN OIL TO CORRECT**, as this condition will correct itself after resuming compressor operation.

Note that repeated addition of oil between oil changes may indicate excessive oil carry-over and should be investigated.



Excessive oil carry-over can damage equipment. Never fill oil reservoir above top of the sight glass



Use only CLEAN containers and funnels to avoid contamination of oil. Provide for clean storage of oils. Changing the oil will be of little benefit if done in a careless manner

OIL CHANGE INTERVAL . The AEON 9000TH Synthetic Lubricating Coolant shall be changed every 8000 hours of operation or as prescribed by the results of an oil analysis, whichever comes first. Note that severe operating conditions (e.g., very dusty, high humidity, etc.), may require more frequent oil changes.

Gardner Denver offers a free oil analysis program with our AEON 9000TH lubricant. The first sample from a new unit should be sent in between 40-100 hours of operation.

DRAINING AND CLEANING OIL SYSTEM - Always drain the complete system. Draining when the oil is hot will help to prevent varnish deposits and carry away impurities. To drain the system, use one of the following methods:

1. Be sure the unit is completely off and that no air pressure is in the oil reservoir.
2. Disconnect, lockout and tagout the power supply to the compressor package.
3. If the unit is not elevated high enough to use the oil reservoir drain line to drain oil, a small hand, electric or air operated pump should be used to drain reservoir through the oil filler opening or from the drain valve.
4. If the unit is elevated so that the oil reservoir drain can be used, empty the oil reservoir through the drain valve to a suitable container or sump.
5. If the drained oil and/or the oil filter element are contaminated with dirt, flush the entire system, reservoir, oil cooler, mixing valve and lines. Inspect the oil separator element for dirt accumulation; replace if necessary. If a varnish deposit exists, contact the factory for recommendations for removal of the deposit and prevention of varnish.

REFILLING OIL SYSTEM - The steps to refill the drained oil system are the same as those already presented for the addition of oil between changes . see page 45, for full details. The only exception is that to fill all the empty lines and components (e.g., oil cooler, compressors, and oil filter) a much larger volume of oil will be required.

The VST110-180 package requires nearly 25 gallons of AEON 9000TH Synthetic Lubricating Coolant to fill all the lines and components. The provided sight glass has a working height of 4", which represent a change of 5.3 gallons between its bottom edge (refill level) to its upper edge (max fill level).

COMPRESSOR OIL FILTER - The oil filter is a vital part in maintaining a trouble-free compressor, since it removes dirt and abrasives from the circulated oil. It should be replaced every 1000 hours of operation and when the oil is changed.

A bypass valve, mounted within the oil filter element, provides uninterrupted oil flow when the pressure drop exceeds 25psid . this is typical behavior for a contaminated element or one exposed to viscous oil during a cold ambient startup. An external pressure switch monitors the same pressure drop and opens between 12 to 18 psid, triggering an advisory message on the AirSmart controller display . See controller manual 13-17-600, advisory #320, for further details. The pressure switch also includes a red, auto-resetting, pop-up visual indicator that confirms a triggered condition.

Note that a dirty oil filter may continuously open its internal bypass valve and introduce unfiltered, contaminated oil into the compressor. It is critical that corrective action is taken once indication of a high pressure drop condition is evident.



Improper oil filter maintenance will cause damage to equipment. Replace filter element every 1000 hours of operation. More frequent replacement could be required depending on operating conditions. A filter element left in service too long may damage equipment.

The filter media is contained within an easily replaced, spin-in assembly that shares a common housing with the oil mixing valve . See Figure 5-3 page 48 for details. Use the following procedure to replace the filter. Do not disturb the piping:

1. Be sure the unit is completely off and that the oil reservoir is depressurized.
2. Disconnect lockout and tagout the power supply to the compressor package.
3. Unscrew the oil filter using a 1" socket and remove.
4. Rotate the filter head (aluminum assembly) to align the channel in the head with the tabs on the oil filter element, lift the threaded part of the filter head until it is seated against its top, and remove the oil filter element away from the oil filter head.
5. Install the new oil filter element if reverse order.

6. Press the oil filter assembly into the housing, and using the 1+socket, tighten down until the o-rings seat within the housing. Do not over tighten.
7. After the compressor is started and pressurized, inspect housing-to-element joint for leaks.

OIL MIXING VALVE . This device, located at the inlet side of the oil cooler, mixes cooled and hot oil prior to delivery to the oil filter and oil injection manifold. It helps to maintain a minimum oil temperature of approximately 140°F at low load level or low ambient temperature conditions. The oil mixing valve shares a common housing with the oil filter . see Figure 5-3 for details.

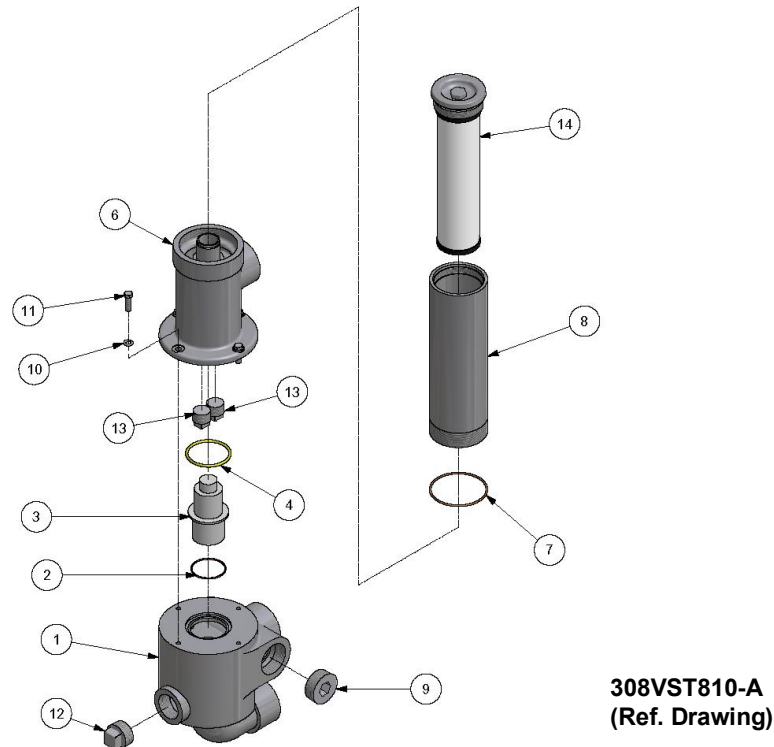

Figure 5-3 – COMBINATION OIL FILTER AND THERMOSTATIC MIXING VALVE

The thermostatic element of this device expands with heat. When the hot oil coming from the separator reservoir is below 140°F, the valve bypasses oil flow around the oil cooler. Within the range of nearly 8°F above 140°F, the valve gradually mixes the hot oil with cool oil coming from the oil cooler. Above this range, the valve reaches its maximum expansion and all the oil is sent to the oil cooler.

OIL FLOW CONTROL VALVES - These devices feed a regulated amount of oil into various areas of the 1st stage compressor and inter-stage manifold. Each of three (3) normally open solenoid valves is paired with one or more in-line orifices to deliver distinct oil flows. When used in combination with a permanently open injection line, the system provides five (5) distinct oil flow regimes - a summary of the logical steps controlling the opening and closing of these valves is shown on the footnotes of Figure 4-3, page33.

The aim of the stepped oil flow modulation is to maintain optimal 1st and 2nd stage compressor discharge temperatures (between 195°F and 220°F). The AirSmart controller governs the oil flow control valve operations. refer to AirSmart Manual 13-17-600 for detailed information on programmed operations of these valves.

The energized state of each valve is visually confirmed by a light emitting diode (LED), housed within the (transparent) electrical plug termination of the cable connected to the valve coil. This information, when used in conjunction with the matching sequence of outputs listed in the AirSmart Manual 13-17-600, will help verify the proper operation of each valve. In case a solenoid valve malfunction is detected (e.g., correct controller output plus LED confirmation, but the valve will not react), the best course of action is to replace the complete valve.

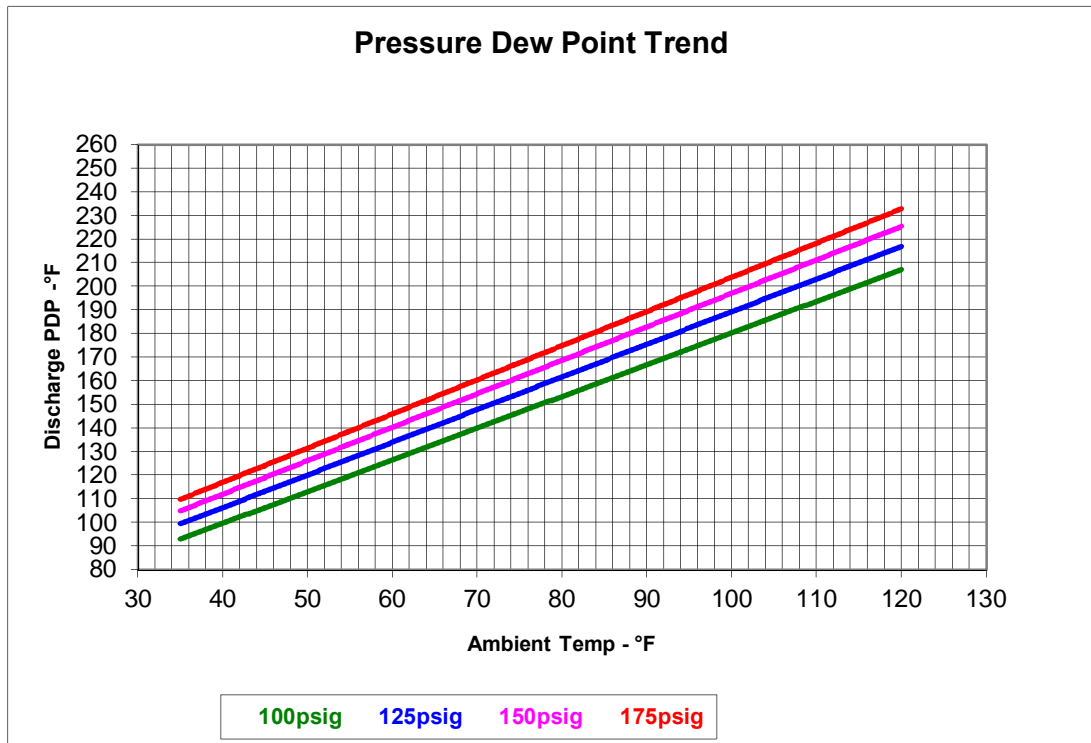

Figure 5-4 – PRESSURE DEW POINT OF COMPRESSED AIR

LOW AIR DEMAND AND PACKAGE OPERATION . During periods of very low air demand, such as when the package is operated in short cycles, the oil system may not reach a high enough temperature to keep water vapor from condensing, in spite of the oil mixing valve bypassing oil flow around the heat exchanger.

Under these conditions, it is recommended that the package operation be prolonged after each unload condition is achieved. This can be easily accomplished by adjusting the %Auto Timer+option in the AirSmart controller. Refer to the AirSmart control user's manual 13-17-600 for detailed programming instructions of this parameter and adjust the %Auto Timer+parameter to a value of at least 5 minutes.

OIL SEPARATION RESERVOIR / COALESCING ELEMENTS - These devices serve multiple functions in the compressor package:

- **Air/oil centrifugal separation** - The bulk of the liquid oil is separated, by centrifugal effects, away from the compressed air and aerosol streams, which is then gravity-collected at the bottom of the reservoir.
- **Oil degassing and holding** - The reservoir has sufficient holding capacity to degas the oil mass before it is drained off on its way to cooling, filtering and re-injection. It also serves as a storage volume for the oil mass migrating from higher elevations (e.g., oil cooler, compressor casings, and piping).
- **Air/oil final separation** - The aerosols and compressed air streams are led to the upper portion of the reservoir, where the coalescing elements (two used) reside. The fine droplets of oil (aerosol) are trapped in each element media, coalesced, then gravity-drained, through a low-point connection and associated tubing (oil return line) into a lower pressure region of the compressor.

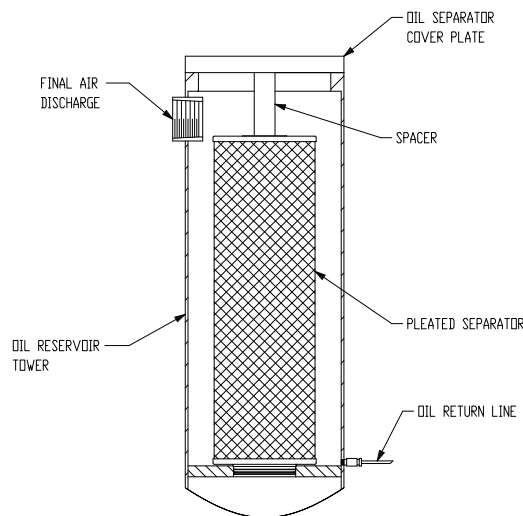

Figure 5-5 – OIL COALESCING ELEMENT (Single Element Shown)

Separation performance - The package oil separation system has been designed to yield 2ppm total oil carryover at the discharge of the air/oil reservoir . the oil content level at the discharge of the package will be lower and will depend on the amount of moisture rejected by the aftercooler.

This high level of performance will be affected by the following typical offset conditions:

- Contaminated (e.g., dirt, varnish, moisture) or damaged (e.g., ruptured) coalescing element.
- Contaminated (e.g., dirt, varnish, moisture) or inadequate oil in use.
- High oil level in air/oil reservoir.
- Blockage of oil return line strainer or orifice.
- Abnormally frequent or fast depressurization cycles - leading to oil foaming.

Oil separator element life cannot be predicted; it will vary greatly depending on the conditions of operation, the quality of the oil used and the maintenance of the oil and air filters. The condition of the separator can be determined by pressure differential gauging or by inspection.

Oil Coalescing Element Monitoring - The AirSmart controller keeps track of the pressure differential across the coalescing element. A pressure differential of 8 psi will trigger a service advisory to change the element and a pressure differential of 15 psi will initiate a system shutdown.



Using oil separator elements at excessive pressure differential can cause damage to equipment. Replace the elements when the "Change Separator" advisory appears.

NOTICE

A sudden drop to zero pressure differential or sudden heavy oil carryover may indicate a ruptured element.

Oil Coalescing Element Service – Use the following procedures to replace or inspect the element:

1. Be sure the unit is completely off and that oil pressure is depressurized.
2. Disconnect, lockout and tagout power supply to the compressor package.
3. Remove screws holding the top plate to the oil separator vessel and lift the top plate away.
4. Lift the element from the reservoir.
5. Inspect and/or replace each element if necessary - shine a light inside each element to reveal areas of heavy dirt, varnish deposits or breaks (ruptures) in its media.
6. Inspect the (sealing) o-ring for damage. Before installing new or old element, apply (heavy) grease to sealing o-ring. Oil may be wiped off by the chamfer and the o-ring could be damaged.
7. Wipe the cover seal o-ring clean and inspect for damage. Replace if necessary.
8. Lower elements into reservoir and center on the chamfer. Press elements down into reservoir. Do not use excessive force as element damage may occur while centering it.
9. Carefully place cover and o-ring seal on the reservoir flange. Check that the adjustable spacer (e.g., pipe segment threaded under cover) does not contact the top of the elements and prevent the cover from seating flush against the matching separator-housing flange. Install and tighten all cap screws.
10. After compressor is started and pressurized, inspect cover-to-reservoir joint for leaks.

SECTION 6
HEAT EXCHANGERS (OIL, AIR), AXIAL COOLING FANS



Compressor, air/oil reservoir, separator chamber and all piping and tubing may be at high temperature during and after operation.



Do not attempt inspection or cleaning of air-cooled heat exchangers until cooling fan has stopped rotating. Disconnect, lockout and tagout package from power supply.



Automatic restarting or electrical shock can cause injury or death. Disconnect, lockout and tagout package from the power supply.

OIL/AIR HEAT EXCHANGERS – The heat of compression absorbed by the oil injected into the compressors (for cooling and lubrication) is ultimately rejected in a convenient medium such as air (for air-cooled cores) or water (for water-cooled cores). Proper operation of these heat exchangers is essential for the following processes:

- The compressors require a stable, cool (140°F typical at 80°F ambient air) supply of injection oil in order to operate at optimal efficiency. Under these conditions, the oil core allows 51pm oil flow with 3.6psid pressure loss.
- The lubricating and cooling oil must be kept at a normal operating temperature below 225°F in order to preserve its longevity.
- The compressed air supply must be delivered into the distribution system at a temperature not exceeding 15°F above the ambient level in order to protect other devices (e.g., filters, dryers, tools, etc) against damage. At 100 psi of discharge pressure, the air core allows the flow of 1368cfm with 1.5psid pressure loss.

AIR-COOLED HEAT EXCHANGERS . Air-cooled cores (radiator-type) are provided as standard feature. A radial fan, located on the discharge side of the heat exchanger core, draws in the required amount of cooling air and expels it through an opening on the enclosure roof. The fan is driven by an inverter-duty, TEFC- electric motor energized by a pulse-width-modulated variable frequency drive.

Refer to Figure 6-1 for estimates of ventilation requirements. Please note that the air-cooled package requires the combined total of the heat exchanger plus the enclosure ventilation flow rates (which include motor ventilation, electronics ventilation, and compressor intake). Furthermore, when package location makes it necessary to duct fresh cooling air in/out, these ducts must be sized with a maximum (total) pressure loss of 0.2+water gauge to avoid impacting the heat exchanger cooling air system.

Minimum Cooling Air Flow Requirements		
CFM		
KW	Air-Cooled Heat Exchangers	Enclosure Ventilation Fan
110	11000	6300
150	14600	6300
180	18300	6300

Figure 6-1 – AIR FLOW CHART

All the required hardware, mechanical and electrical connections have been made at the Gardner Denver factory, thus the only regular maintenance required is to keep the exterior core fins free from dirt and other airborne debris per the following procedure:



Air-cooled heat exchanger cores are fabricated from aluminum. Do not use caustic liquids to cleanse core or permanent damage will take place.

1. Be sure the unit is completely off and that oil reservoir is depressurized.
2. Disconnect, lockout and tagout power supply to the compressor package.
3. Open and/or remove enclosure door panels adjacent to cooler assembly
4. Locate cooler housing side covers (See Figure 6-2) and remove by unscrewing fasteners.
5. Inspect core area. If blocked with debris, use a moderate (e.g., 100psi) source of compressed air and/or water while directing nozzle (pointed through core to outside) to dislodge debris and clean. Vacuum (applied from outside) can also be employed to clean the heat exchanger cores.
6. Remove all loose debris and water from cooler box after cleaning process is complete.
7. Re-attach cooler housing side covers with provided fasteners and re-install enclosure door panels..

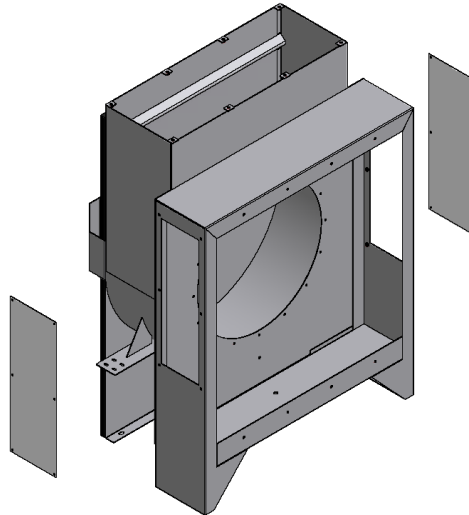

Figure 6-2 – COOLER HOUSING SIDE COVERS



Automatic restarting or electrical shock can cause injury or death. Disconnect, lockout and tagout package from the power supply.

AXIAL COOLING FANS

1. Follow Lock-Out Tag-Out procedures to de-energize the package. Allow adequate time for the VFD capacitors to fully discharge before beginning maintenance.
2. Exercise caution around compressor parts after stopping the package for service. Fans and coolers will be hot after stopping the compressor.
3. Remove access panels and guards as needed to gain access to the fan blades.
4. Cover motors, mixing valves, fan motors and other electrical components to prevent damage from the cleaning process.
5. Use a mild detergent or degreaser to soften and dissolve accumulated grime.
6. Using a soft cloth or sponge, remove the surface grime from both sides of the blade surface.
7. Wipe up and remove all traces of cleaning residue and cleaning materials.
8. Reinstall all access panels and guards that were removed to access the fans.
9. Follow Lock-Out Tag-Out procedures to re-energize the package.
10. Jog fans to verify there is no interference with the guard or cowling ring before the package is placed back in service.

All axial cooling fans should be inspected and cleaned at the same interval as the heat exchangers are. Ambient conditions will determine the actual maintenance interval at each installation

WATER-COOLED HEAT EXCHANGERS . Optionally water-cooled cores (fixed shell-and-tube type) are available. The air core is a single pass (air in the tubes) design and the oil core is a double pass (oil in the shell) design. The cooling water is fed to the cores in a series arrangement . it passes through the air core first and proceeds through the oil core before exiting the package. Please refer to Figure 6-3 for estimates of requirements.

AIR & OIL COOLER (Series Water Piping)							
KW	Model	Water flow requirements at various inlet water temperatures (gpm)				Maximum Water Flow (gpm) *	Approximate (total) water pressure drop @ 90° F water flow (psi)
		60° F	70° F	80° F	90° F		
All	VST110-180A	36.7	46.9	65.0	106.0	106.0	36.9

* Flows exceeding "Maximum Water Flow" will cause severe erosion and will void unit warranty.

Figure 6-3 – WATER-COOLED HEAT EXCHANGER COOLANT REQUIREMENTS

The water supply shall be capable of delivering the flow/temperature combinations shown in Figure 6-3, page 55, at a minimum pressure of 40 psig (2.8 bar) - the water flow rates shown are approximate and a guide to sizing of piping, cooling tower and other water system equipment.

The maximum allowable supply water pressure is 150 psig (10.3 bar) and the maximum allowed [package] outlet water temperature is 110°F (43°C). If a water supply with a temperature lower than 60°F (16°C) is used, heat transfer areas of the coolers may be fouled due to low water flow velocities, resulting in poor cooler performance and shortened operational life.

All the required hardware, mechanical and electrical connections have been made at the Gardner Denver factory. Regular maintenance is required to keep the interior core areas free from dirt and other fouling agents. In order to protect package components that are in contact with the cooling water from attack by corrosive or fouling agents, we recommend that the cooling water meet the following quality standards:

- Total Dissolved Solids (TDS)..... <500 ppm
- Iron <2 ppm
- Total Hardness..... <60 ppm
- Silica <25 ppm
- Oil and Grease..... <5 ppm
- Sulfate <50 ppm
- Chloride <50 ppm
- Nitrate <2 ppm
- Corrosivity..... Langelier Index between 0 to 1

It is strongly recommended that a reputable, local firm be contracted to evaluate the quality of water available and recommend corrective and/or preventive steps to meet our requirements.

WATER FLOW REGULATING VALVE (OPTIONAL HARDWARE). . This device is used to adjust the flow of cooling water in proportion to its temperature. It is a normally closed (two-way) valve which opens once the thermostatic bulb senses a predetermined water temperature level and then continues to modulate water flow to maintain water temperature . within a 2° F to 5° F span. The package piping provides a permanent bypass line (1/4" tube) around the flow regulating valve to ensure water flow around the sensing bulb when the valve is in the closed position . it does not provide a complete shutoff of water flow.

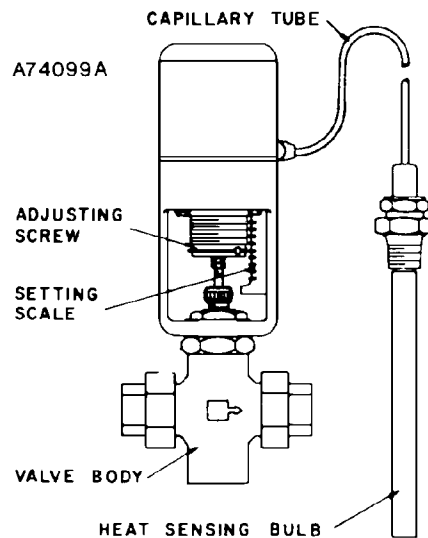

Figure 6-4 – WATER CONTROL VALVE

Adjustments – The regulator valve shall be adjusted so that it closes when the cooling water entering and exiting the package are at the same temperature . a condition that is present after the compressors have stopped and the heat exchangers have cooled down. This adjustment mode will prevent the circulation of cooling water when it is not needed. Adjustment to the regulator valve can be made as follows:

- To decrease water flow (e.g., increase exiting cooling water temperature) turn the adjusting screw from left to right, increasing spring tension.
- To increase water flow (e.g., decrease exiting cooling water temperature) turn the adjusting screw from right to left, decreasing spring tension. The groove at the lower edge of the adjusting screw is an index line for use with the index scale 0 to 8 in obtaining a desired setting.

Care must be used when handling the capillary tube; a kink or break in the tubing or connections will make the valve inoperative. Never attempt to change capillary length. Excess capillary tube should be carefully coiled and placed so that damage will not occur with normal maintenance or traffic past the unit.

If a leak develops through the packing, tighten the packing gland nut firmly with a wrench to reseal the packing around the valve stem, back off the nut until loose and finally retighten the nut finger tight. Tightening the packing nut too tight may cause erratic operation. An occasional drop of oil on the valve stem at the packing nut will prolong packing life.

If the valve malfunctions, check for a bend or binding in the capillary tube, paint or corrosion on valve stem, foreign material in valve, erosion or thermal system (capillary) failure.

Water Flow Shutoff Valve (Optional Hardware) - This device completely shuts off the flow of cooling water when the compressors are not operating. Its normally closed state prevents the waste of cooling water even in the case of power failure. It is a common companion to the water flow regulating valve.

The water flow regulating valve and the water shutoff valve are factory-installed options. If the presence of foreign material or scale formation in the cooling water is likely, the use of a strainer in the inlet water line is recommended.

SECTION 7 AIR FILTER

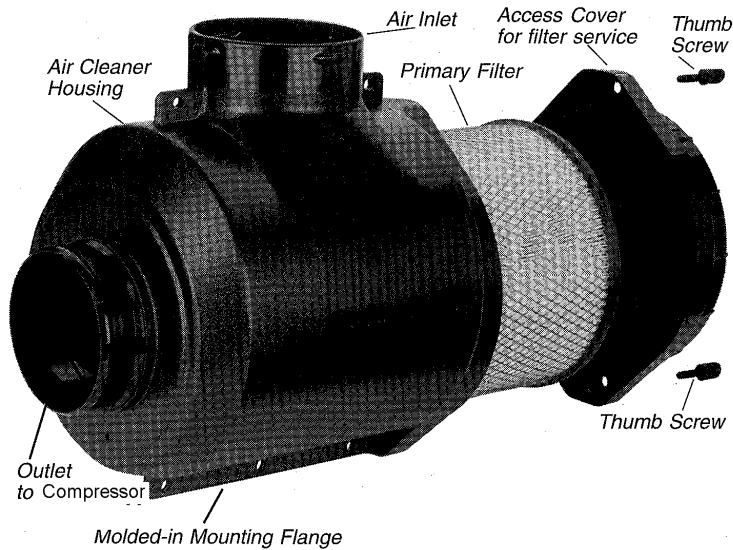

Figure 7-1 – AIR FILTER (STANDARD)

AIR FILTER - These devices (two are used) clean the air stream entering the 1st stage compressor inlet and are furnished as standard equipment with the compressor package. Each single, high efficiency, synthetic media element is housed in a non-corrosive housing.

Efficient compressor package operation depends on the unrestricted, clean supply of fresh air delivered by the air filters. In turn, the longevity of the filter element depends on the cleanliness of the local environment.

NOTICE

Use only genuine Gardner Denver air filter elements on Gardner Denver compressor units. Genuine parts are available through your authorized Gardner Denver distributor.



Do not oil this element. Do not wash in inflammable cleaning fluids. Do not use solvents other than water. Improper cleaning may damage the element.

Never operate the unit without the air filter element. Never use elements that are damaged, ruptured or wet. Keep spare elements on hand to reduce downtime. Store elements in a protected area free from damage, dirt and moisture. Handle all parts with care.

Filter Element Inspection and Replacement:

1. Unscrew thumbscrews fastening the access cover to the filter housing, then remove the cover and element.
2. Visually inspect housing inner tube against which the element makes a seal. Wipe dirt from outer surface if necessary. Also visually inspect the matching o-ring seal that is bonded to the element for defects and dirt, then wipe clean if necessary.
3. Visually inspect media. If flaws (e.g., tears of media, damage to sealing o-ring, etc.) are evident or if the pressure loss has triggered the vacuum switch (activation level is 30 inches water gauge) provided with the package instrumentation, replace the element. Cleansing the element with air or water is not recommended, as media damage is very probable.
4. Replace element and cover, then fasten cover to filter housing with thumbscrews.

SECTION 8 SHAFT COUPLING

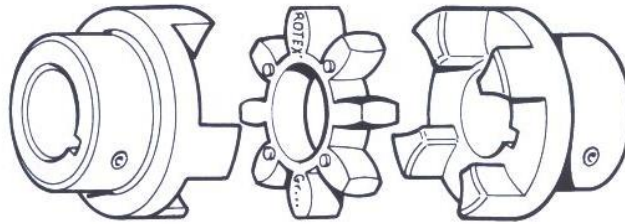

Figure 8-1 – COUPLING COMPONENTS



Rotating machinery can cause personal injury or death. Turn the unit completely off, open the main disconnect, lockout and tagout before servicing the coupling.

SHAFT COUPLING . Main motors drive their companion compressors by means of curved jaw-type couplings. Each coupling hub is fixed to the shaft with a setscrew and key combinations. The power is transmitted through a meshing, single, dry, vibrations damping element . see Figure 8-1, for details of the main components.

The close-coupled arrangement of motor and compressor, through a machined cast housing, provides automatic alignment of shafts and coupling. The coupling assembly requires no lubrication.

Coupling Element (Rotex size 65) Inspection and Replacement:

1. Disconnect, lockout and tagout power supply to the compressor package.
2. Remove fasteners securing coupling guard to access opening on compressor-motor housing and remove guard.
3. Depending on the bore-to-shaft fits (e.g., clearance or interference) on either of the coupling hubs, proceed as directed. For hub-to-shaft clearance fit hubs:
 - Loosen setscrews fastening hubs to shafts and slide hubs away from each other to allow removal of coupling element.
 - Inspect coupling element for signs of wear and tear such as indentations, cracks, deformation, extrusions, etc. Replace, if necessary.
 - After engaging each hub on the matching recesses of the coupling element, check that the gap between the hub flats (see dimension $\frac{1}{16}$ on Figure 8-2) is no less than 1.38/1.50 inches (35/38 mm). A smaller gap will produce abnormal wear of the element by friction and excessive thermal expansion . the latter could cause compressor damage by axially displacing the input shaft. Make sure that keys are in proper alignment with key-ways on hubs.

Components

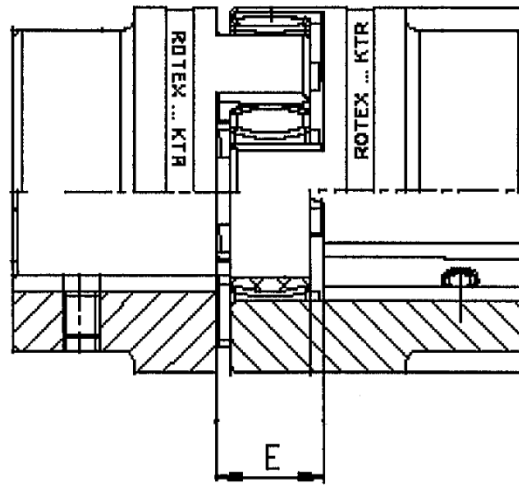
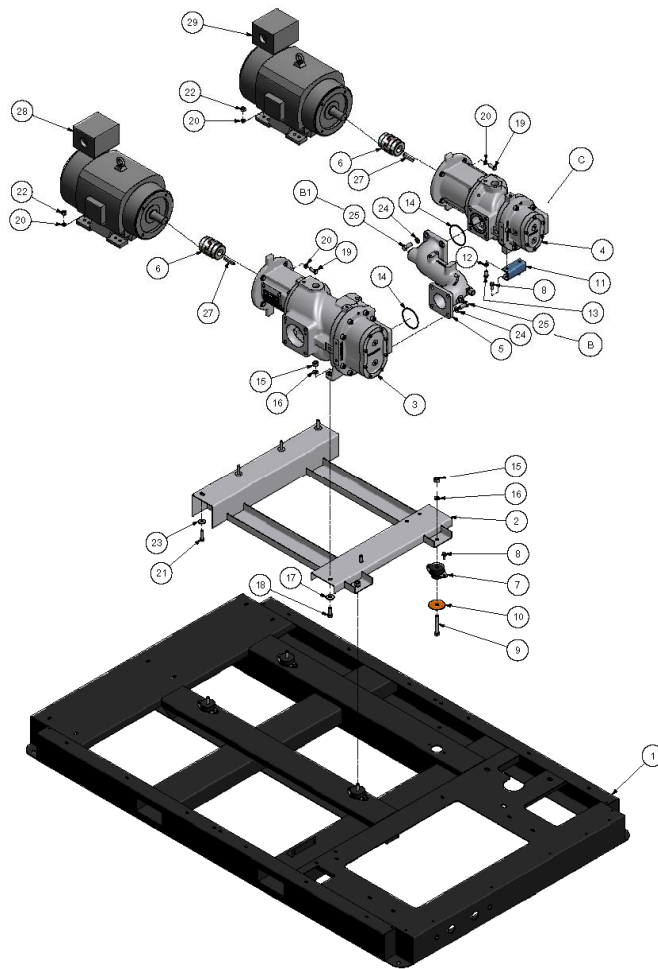

Figure 8-2 – COUPLING ELEMENT

- Apply a thread-locking compound to the hub set screws (M10 size) and tighten to 150.5 lb-in (17 N-m) of torque. Reinstall coupling guard with provided fasteners.
4. For hub-to-shaft interference fit hubs, main drive motor removal is necessary.



300ETK810-C
(Ref. Drawing)

Figure 8-3 – MOTOR REMOVAL HARDWARE

- Remove coupling guard by removing four bolts
- Remove two bolt/nut/washer combos securing [main motor] rear support to base frame.
- Insert temporary support between adaptor casting and support frame (e.g., wood beam) to maintain compressor level when main motor is retrieved.
- Remove four bolts securing main motor to adaptor.
- Slide/Pull main motor away from adaptor until coupling hubs separate and allow removal of spider.
- Inspect coupling element for signs of wear and tear such as indentations, cracks, deformation, extrusions, etc. Replace, if necessary.
- Re-assemble main motor and cooling fan components in reverse order of disassembly.
- After engaging each hub on the matching recesses of the coupling element, check that the gap between the hub flats (see dimension $\frac{3}{16}+$ on Figure 8-2) is no less than 1.38/1.50 inches (35/38 mm). A smaller gap will produce abnormal wear of the element by friction and excessive thermal expansion. the latter could cause compressor damage by axially displacing the input shaft. Make sure that keys are in proper alignment with key-ways on hubs.
- Apply a thread-locking compound to the hub set screws (M10 size) and tighten to 150.5 lb-in (17 Nm) of torque. Reinstall coupling guard with provided fasteners.

Interference-fitted Coupling Hub Installation and Removal . In the event that a coupling hub has to be removed, please note that these are designed to fit on compressor and motor shafts with a transitional interference fit. Coupling hubs and their companion shafts which have bore diameter which fall in the interference range of the design fit, must be installed or removed with the aid of a pulling tool and/or heat dilation. The recommended steps are based on the assumption that the main motor has been pulled away from the compressor and that the motor adaptor housing is still attached to the compressor.

Coupling Hub Installation:

- Have coupling installation tool kit part number 302SBV074 available . contact GD for sourcing details.
- Assemble tool kit components unto coupling hub as shown on Figure 8-4, page 64.
- Make sure that the keyway on the coupling hub and its companion shaft are properly de-burred and clean and that the key fits easily into either.
- Thoroughly cleanse the surface of the companion shaft and cover it with a thin film of anti-seize lubricant part number 25BC850 . contact GD for sourcing details.
- Expose complete assembly to heat source until the coupling hub reached a temperature of 200° F. Note that an oven is a preferred method to heat up the hardware.
- With the help of heat insulating gloves, remove the coupling hub and tool kit assembly from the heat source and quickly bring it to the companion shaft. Engage the coupling hub bore unto the companion shaft and slide until the latter contacts the stop . item #1 on Figure 8-4, page 64.
- Once the coupling hub has cooled down sufficiently to grip the companion shaft, remove the installation tool kit.

Coupling Hub Removal:

- Have removal tool part number 90500151 available . contact GD for sourcing details.
- Before removing an interference fitted hub, note and record the position of the hub with relation to the end of the companion shaft. The hub must be re-installed at same relative position, in order to provide the proper clearance for the coupling.
- Assemble removal tool unto coupling hub as shown in Figure 8-5, page 64. Make sure that the shaft protector piece is captured between the puller screw and the end of the shaft.
- Apply torque to the puller screw with a suitable torque wrench to pull coupling hub away from the shaft.
- If torque applied to puller screw exceeds 130ft-lb, it indicates that a heavy interference fit between the coupling hub and the companion shaft is present and that heat dilation must be used to expand the coupling hub and loosen its grip on the shaft surface. Secure a suitable heating source and apply heat to the coupling hub body while slowly rotating the companion shaft assembly by means of the removal tool handle. Once the coupling hub metal has expanded enough, the present tension of the removal tool will pull the coupling hub away from the shaft.

 **DANGER**

Heated surfaces of coupling hub and installation or removal tools may cause severe burns. Make sure to use suitable heat protective gloves and clothes.

NOTICE

If heat was applied to the [compressor] coupling hub during its removal, there is the possibility that the companion shaft seal has been damaged and it must be replaced. Contact Gardner Denver for further instructions.

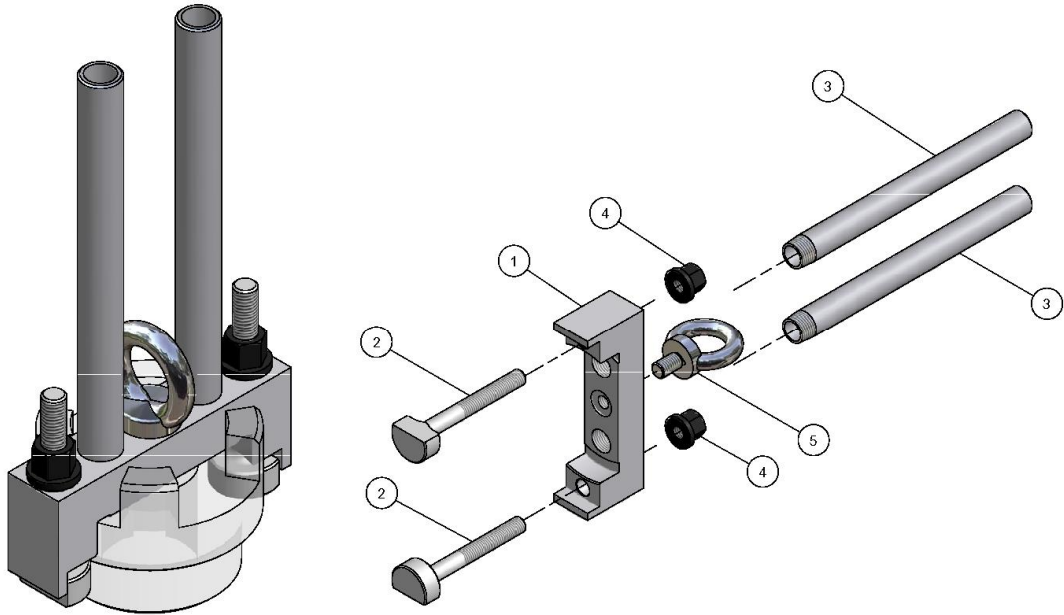

VIEW SHOWN ASSEMBLED ONTO COUPLING HUB

Figure 8-4 – COUPLING INSTALLATION TOOL KIT

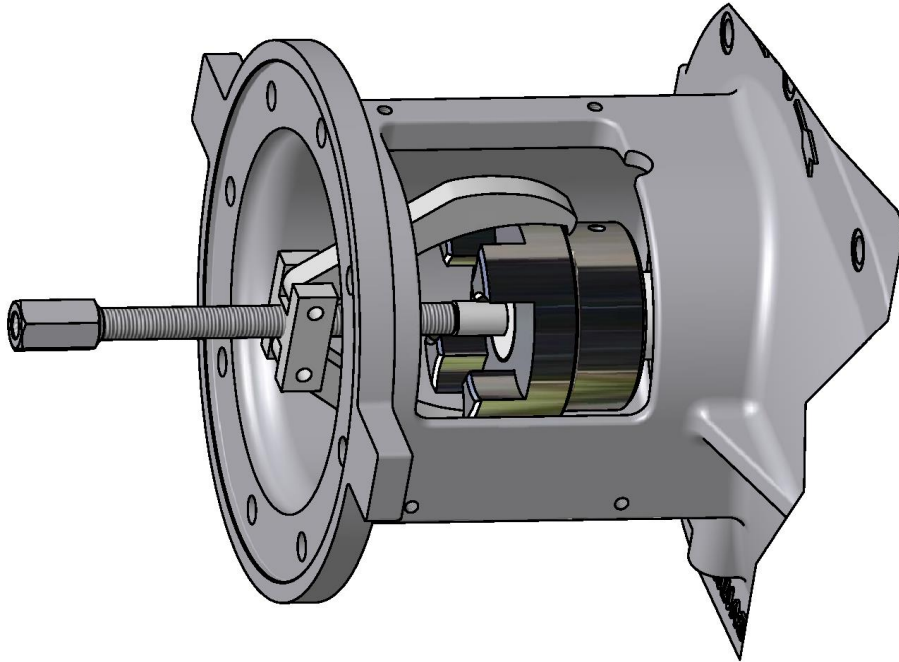

Figure 8-5 – COUPLING REMOVAL TOOL KIT

SECTION 9

MINIMUM PRESSURE/CHECK VALVE

MINIMUM PRESSURE/CHECK VALVE - This device maintains minimum pressure within the air/oil reservoir, thus insuring [cooling/lubricating] oil injection flow into the compressors. It also serves as a check valve to prevent back flow of compressed air flow from the customer's piping or pipe network back into the compressor package when the compressor is not active. The valve does not require maintenance or adjustment. If the valve fails to function, check the valve stem O-ring for sealing, valve orifices for restriction, or valve and valve seat for burrs and dirt. Repair kits are available from your local authorized Gardner Denver distributor.



Before servicing the minimum pressure valve, always stop the unit, release air pressure, lockout and tagout the power supply to the compressor package. Failure to release pressure or properly disconnect the power may result in personal injury or death.

Working spring within valve body is under tension. Failure to relieve spring tension gradually may cause serious injury upon cap removal.

Minimum Pressure/Check Valve Inspection:

1. Be sure the unit is completely off and that the oil reservoir is depressurized.
2. Disconnect, lockout and tagout power supply to the compressor package.
3. Carefully and gradually unscrew the valve cap from the body . this will also release tension from working spring within valve body. After cap removal, all internal parts can be retrieved . note their relative positions during disassembly to help the re-assembly process. See Figure 9-1, page 66
4. Inspect and/or replace parts.
5. Re-assemble by following steps 4 to 3 in reverse order.

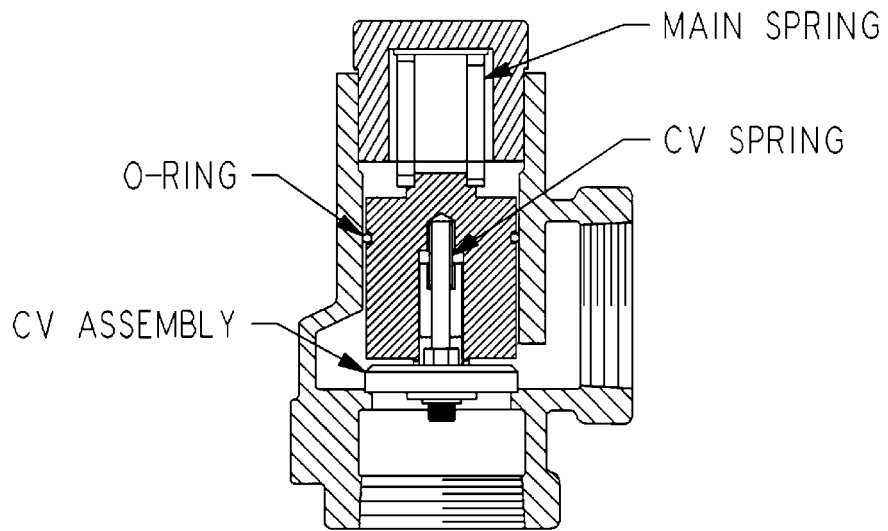

Figure 9-1 – MINIMUM DISCHARGE PRESSURE/CHECK VALVE

SECTION 10 INLET CONTROL VALVE

INLET CONTROL VALVE . This device is located at the intake flange of the compressor. During compressor stoppage, planned or accidental (e.g. power failure), it blocks off the compressor intake and allows it to remain pressurized and ready for quick re-start. A spring-loaded check feature is provided as added insurance against air or oil backflow

During compressor operation, the underside of the poppet is vented to atmosphere via a 3-way solenoid valve, allowing the poppet to fall (open) and feed fresh air to the compressor inlet-the spring loaded check feature is pushed open by a very small pressure differential resulting from the incoming air stream. During stopped operation modes (e.g. commanded from keypad or initiated by protective shutdown), the compressing the spring loaded check feature and blocking-off the compressor intake.

Refer to Parts List 13-17-501 for spare parts.

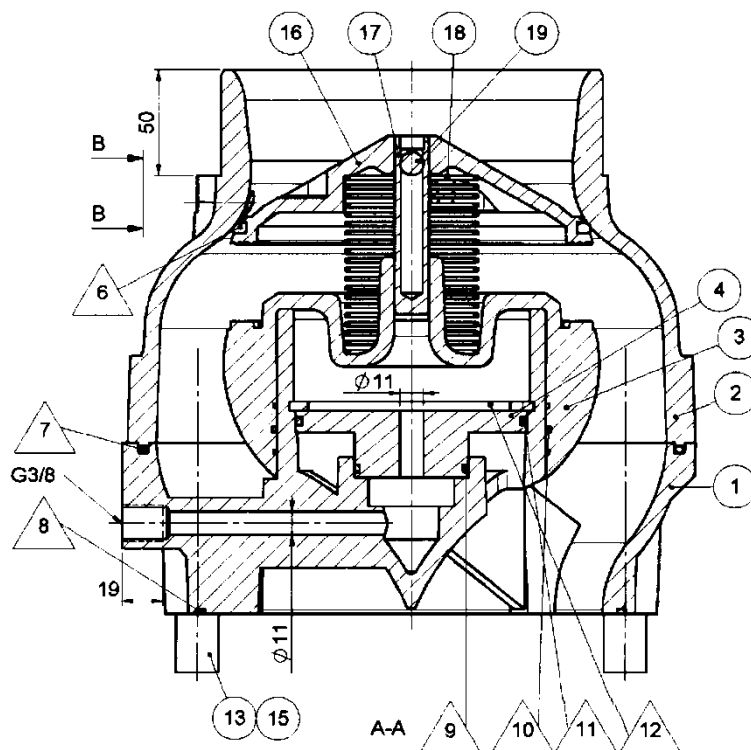

Figure 10-1 – INLET CONTROL VALVE (BODY)

Inlet Control Valve (Body) Inspection - The valve does not require maintenance or lubrication. If air/oil leaks develop across the valve disc during pressurized conditions (e.g., machine stopped), valve seat and disc should be inspected for wear and tear signs:

1. Be sure the unit is completely off and oil reservoir is depressurized.
2. Disconnect, lockout and tagout power supply to the compressor package.

3. Close (when provided) valve isolating compressor package from air system.
4. Identify (by position) each tube connected to the valve body and remove.
5. Remove four bolts (Item 13) securing valve body to compressor body and remove valve.
6. Inspect poppet seal (O-Ring) (Item 6, 10) for wear and tear. Replace, if necessary.
7. Remove lock ring (Item 12) and pull out cover (Item 4).
8. Inspect seals (Item 9, 11) for wear and tear. Replace, if necessary.
9. Reassemble inlet control valve in reverse order.

SECTION 11 PRESSURE RELIEF VALVE

Pressure Relief Valve - This device protects the pressure-containing components of the compressor package against pressures accidentally exceeding 200 psig. It is installed on the dry-side of the oil separation reservoir.

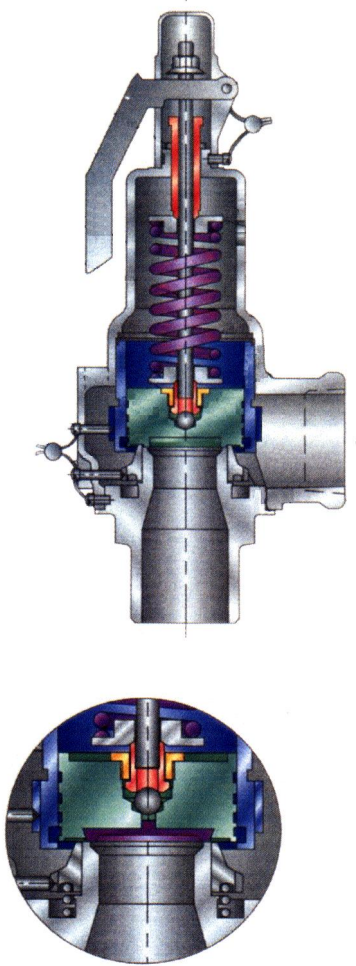

Figure 11-1 – PRESSURE RELIEF VALVE

⚠ DANGER



Before inspecting the pressure relief valve, release air pressure, lockout and tagout the power supply to the compressor package. Failure to release pressure or properly disconnect the power may result in personal injury or death.

⚠ CAUTION

Never paint, lubricate or alter a relief valve. Do not plug vent or restrict.

⚠ DANGER



Operation of the unit with improper relief valve setting can result in severe personal injury or machine damage. Ensure properly set valves are installed and maintained.

Pressure Relief Valve Inspection – The pressure relief valve has no user-serviceable or repairable components. However, it should be tested for proper operation at least once every year. To test the relief valve, raise the system operating pressure to its normal level and manually open the valve with the hand lever. Hold the valve open for a few seconds and allow it to snap shut.

SECTION 12

VENTILATION FANS, FILTERS (ELECTRICAL ENCLOSURE)

Ventilation Fans/Filters - The electronics housed in the standard IP54 enclosure box are ventilated by a combination of triple intake and discharge side air filters and a single roof-mounted axial fan. Refer to Figures 1-4 and 4-1, pages 12 and 29 in their corresponding Sections of this manual, for details.

Filter Inspection - In order to ensure the electronics operate at peak efficiency and free from troublesome temperature-related stoppages, it is imperative that the filter elements be kept clean:

1. Be sure the unit is completely off and oil reservoir is depressurized.
2. Disconnect, lockout and tagout power supply to the compressor package.
3. Remove the access panel, located below the electrical enclosure area, by unlatching all four (4) provided latches. The three (3) intake filter assemblies, located on the floor of the electrical enclosure, are now accessible.
4. Remove the filter elements from each bracket by prying open the retaining grill area.
5. Inspect the elements. If dirty, gently clean with soapy water and allow to dry completely before re-installation. If damage is evident, replace.
6. Replace elements into frame and replace snap grills.
7. Replace access panel in reverse order.
8. Open the electrical enclosure doors. The three (3) discharge filter assemblies are located on the upper rear area of the electrical enclosure, above the VFD modules.
9. Repeat steps 4 through 6 to inspect, clean and replace these filter elements.
10. Close door.

**SECTION 13
MOTOR LUBRICATION**



Rotating machinery can cause injury or death. Open main disconnect, lockout and tagout power supply to compressor package before working on the electric motor.

Motor Lubrication - Long time satisfactory operation of an electric motor depends in large measure on proper lubrication of the bearings. The following charts show recommended grease qualities and re-greasing intervals for ball bearing motors. For additional information refer to the motor manufacturer's instructions. The following procedure should be used in re-greasing:

1. Disconnect, lockout and tagout power supply to the compressor package.
2. Locate the automatic grease relief fittings (one at each motor bottom end) and make sure that their spring loaded covers are operational.
3. Locate the grease fittings provided at each end of the motor top end . be aware the one or both may be relocated away from the motor for easier access. Wipe each greased fitting clean and add grease with a hand - operated gun until excess grease starts draining from the companion grease relief fitting.
4. Wipe off only excess grease expelled by the automatic grease relief fittings.
5. Re-start the unit.

Main Motor Grease Specifications:

MANUFACTURER	TRADE NAME	GD Part No.
KLUBER	KLUBER QUIET BQ 72-72	28H311 (400 Gram Cartridge) 28H312 (1Kg can) 28H313 (25 Kg pail)

ELECTRIC MOTOR REGREASING INTERVAL

Type of Service	Typical	Rating	Lubrication Interval
ALL	Continuous Operation Humid, dirty, high ambient sites	110-180 kW	3000 hrs

SECTION 14 MAINTENANCE SCHEDULE

SERVICE CHECK LIST

Daily Checks:

- **Air Filters (Compressor)** - Replace when controller displays %CHANGE AIR FILTER+message. Refer to Section 7, page 57 for air filter details.
- **Oil Separator Element** - Replace when controller displays %CHANGE OIL SEPARATOR ELEMENT+. Refer to Section 5, page 42 for oil separator element details.
- **Air/Oil Reservoir Oil Level** - Check the reservoir oil level during compressor operation only - add oil if required. Refer to Section 5, page 42 for full details. DO NOT MIX LUBRICANTS.
- **Start/Modulation/Stop Operation** . Verify that compressors maintain steady compressed air pressure.
- **AirSmart Operational Parameters** . Maintaining a periodic log of package critical parameters (e.g., pressures, temperatures, speeds, load levels, etc) helps identify when abnormal operation occurs.
- **AirSmart Controller Messages and Alarms** . Acknowledge the presence of an abnormal condition and take action to correct it.

Weekly Checks:

- **Heat Exchangers (air-cooled)** - Check for dirt accumulation on (air-cooled) air/oil heat exchanger finned surfaces. Refer to Section 6, page 52 for detailed instructions to clean heat exchanger surfaces.
- **Axial cooling fans** . Check for grime and dirt build-up on fan blade surfaces. Refer to Section 6 for detailed instructions to clean axial cooling fan blade surfaces
- **Air Filters (Electrical Box)** . Check filter elements for dirt accumulation. Refer to Section 7, page 57 for detailed instruction to clean filter elements.

Every 1000 Hours:

- **Oil Filter** - Replace.
- **Oil** - Sample and analyze.

Every 3000 Hours:

- **Motor Lubrication** – Inspect motors for abnormal noise and vibration. Grease-with recommended grease as shown in Section 13, page 72 of this manual.

Every 8000 Hours (Or as Prescribed by Oil Analysis Results):

- **Compressor Lubricant** – Replace.

Yearly Checks:

- **Heat Exchangers (air and water-cooled)** . Check cooling performance of air and oil cores . see Section 6, page 52 of this manual for details on typical performance expectations as well as recommended cleaning procedures.
- **Pressure Relief Valve** – Check operation of device . see Section 11, page 69 for test procedure.
- **Compressor/Motor shaft couplings** – Check coupling element for signs of wear and tear . see Section 8, page 59 for detailed instruction on coupling inspection procedures.

SECTION 15 TROUBLESHOOTING



Air/oil under pressure will cause severe personal injury or death. Shut down compressor, relieve system of all pressure, disconnect, lockout and tagout power supply to the compressor package before removing valves, caps, plugs, fittings, bolts and filters.

SYMPTOM	POSSIBLE CAUSE	REMEDY
Compressor fails to start	1. Main disconnect open	1. Check and reset.
	2. Blown fuses in control box	2. Replace fuse.
	3. Variable Frequency Drive fault active	3. Investigate cause of fault and press %STOP/RESET+button to reset.
	4. Shutdown event sensed by controller not re-set	4. Investigate cause of fault and press %STOP/RESET+button to reset.
	5. Read error message on control panel	5. Take appropriate action. See Manual 13-17-600.
	6. Remote Contact is open	6. Replace switch or jumper.
	7. Compressor lock-up	7. Confirm compressor shaft is not free to turn, then call Gardner Denver for further instructions. See %High Discharge Air Temperature+, this section.
Compressor starts but stops after a short time	1. High discharge temperature	1. See %High Discharge Air Temperature+,this section.
	2. Low oil injection pressure	2. Check oil level. Check oil filter dP.
	3. Blown fuse in control box	3. Replace fuse (investigate if fuses continue to blow).
	4. Variable Frequency Drive overload sensor tripped	4. Reset and investigate cause of overload.
	5. Compressor lock-up	5. Confirm compressor shaft is not free to turn, and then call Gardner Denver for further instructions.

SYMPTOM	POSSIBLE CAUSE	REMEDY
Compressor does not unload (or load)	1. Improperly adjusted controller	1. Refer to Manual 13-17-600 and adjust control.
	2. Feed pressure regulator not adjusted	2. Inspect, adjust and replace pressure regulator.
	3. Feed 3-way solenoid valve malfunction	3. Repair, clean or replace valve.
	4. Inlet valve stuck	4. Inspect and replace valve.
	5. Blow down valve malfunction	5. Repair, clean or replace valve.
Compressor cycles from load to unload excessively	1. Insufficient receiver capacity	1. Increase receiver size
	2. Restriction in service piping	2. Inspect and clean service piping.
	3. Restriction in control tubing	3. Inspect and clean control tubing.
Compressor starts too slowly	1. Acceleration time in VFD set too long	1. Contact your Gardner Denver distributor.
	2. Minimum Pressure/Check Valve is leaking	2. Repair or replace.
Compressor is low on delivery and pressure	1. Improperly adjusted control	1. Refer to Manual 13-17-600 and adjust control.
	2. Restricted air filter	2. Clean or replace filter element.
	3. Inlet valve not fully open	3. Inspect, adjust or replace feed solenoid valve and/or pressure regulator.
	4. Minimum pressure valve stuck closed	4. Inspect, service or replace valve.
	5. Air leaks in service piping	5. Inspect or replace solenoid valve. Ensure local ambient temp has not exceeded 113°F. limit.

SYMPTOM	POSSIBLE CAUSE	REMEDY
Excessive oil consumption	1. Oil separation malfunction	1. See %Oil Carryover+in this section.
	2. Oil leaks at fittings and gaskets	2. Detect and correct oil leaks.
	3. Shaft seal leaking	3. Inspect or replace shaft seal.
High discharge air, oil Temperature (air, water cooled cores)	1. Thermostatic mixing valve stuck on bypass mode	1. Inspect or replace valve.
	2. Clogged oil filter	2. Inspect and replace filter.
	3. Clogged cooler (interior)	3. Inspect and clear cooler.
	4. Clogged oil lines	4. Inspect and clear oil lines.
	5. Low oil level	5. Add oil to proper level.
	6. Low oil injection pressure but normal discharge pressure	6. Oil flow control solenoid valve malfunction . Refer to Section 5, page 42 %Compressor Lubrication+for details.
High discharge air, oil Temperature (air cooled cores)	1. Dirty or clogged cooler outer surfaces.	1. Inspect and clean cooler outer surfaces.
	2. Insufficient cooling air flow	2. Verify {ductwork) back pressure does not exceed .1+water gauge.
High discharge air, oil Temperature (water cooled cores)	1. Optional water temp regulating or shut-off valve malfunction	1. Refer to Section 6, page 52%Heat Exchangers+for details.
VFD shutdown on overheat	1. Ambient air exceeds 45°C	1. Check local ventilation and improve, if necessary.
	2. VFD air filters dirty	2. Inspect, clean or replace elements.

SYMPTOM	POSSIBLE CAUSE	REMEDY
Oil carryover	1. Overfilling oil separation vessel	1. Drain excess oil from system.
	2. Clogged oil return line orifice	2. Inspect and service.
	3. Clogged oil return line strainer	3. Inspect and service.
	4. Clogged, broken, or loose oil return line fittings	4. Inspect and tighten or replace.
	5. Ruptured oil separator element.	5. Replace element.
	6. Loose assembly	6. Tighten all fittings and gaskets.
	7. Foam caused by use of incorrect oil	7. Use Gardner Denver AEON 9000TH oil only.
	8. Minimum pressure valve malfunction . discharge pressure below 80 psig	8. Repair or replace.

Standard Warranty

Oil-Lubricated Rotary Screw / Rotary Vane Compressor Packages

APEX, APEX VS, Electra Screw, Integra, Electra Saver II, Electra Saver, L, LRS, VS, VST, V, HV, HV RS, and HR Series

STANDARD WARRANTY

Gardner Denver (the “Company”) warrants to each original retail purchaser (“Purchaser”) of its new products from the Company or its authorized distributor that such products are, at the time of delivery to the Purchaser, free of defects in material and workmanship. **This Standard Warranty statement applies to compressors shipped after April 1st, 2015.**

STANDARD WARRANTY PERIOD

The Company’s obligation under this warranty is limited to repairing or, at its option, replacing, during normal business hours at an authorized service facility of the Company, any part which in its judgment proved not to be as warranted within the applicable warranty period as follows. **Regular maintenance in accordance with the service manual is required. Use of genuine Gardner Denver OEM parts and lubricants are highly recommended. If a component failure is deemed a result of using non-genuine Gardner Denver parts and lubricants, warranty will not be allowed.**

COMPONENT	STANDARD WARRANTY COVERAGE	DETAILS
Package	12 months from startup or 15 months from date of shipment to first purchaser, whichever occurs first	All components within the package, excluding normal wear items
Airend	24 months from startup or 27 months from date of shipment to first purchaser, whichever occurs first	Normal wearing items, such as shaft seals and inlet valve components, along with the servicing of these items is not covered under the warranty unless deemed as material or workmanship defects. Any disassembly or partial disassembly of the airend, or failure to return the “unopened” airend per Company instructions, will be cause for denial of warranty
Electric Motors	12 months from startup or 15 months from date of shipment to first purchaser, whichever occurs first	Includes both drive motor and cooling fan motor. For nonstandard motors, the original manufacturer’s warranty will take precedence.
Major Package Components	24 months from startup or 27 months from date of shipment to first purchaser, whichever occurs first	Includes package controller, variable frequency drive if applicable, air/oil reservoir, air/oil cooler, and precision mixing valve (VS Series)
Labor	<p>Package / Electric Motors: 12 months from startup or 15 months from date of shipment to first purchaser, whichever occurs first</p> <p>Airend / Major Package Components: 24 months from startup or 27 months from date of shipment to first purchaser, whichever occurs first</p>	Service will be provided by Company representative or authorized service personnel, for repair or replacement of any product or part which in the Company’s sole judgment is proved not to be as warranted. Labor shall be limited to the amount specified in the Company’s labor rate schedule. All costs of transportation of product, parts, and repaired or replacement parts claimed not to be as warranted to and from such service facilities shall be borne by the Purchaser. The Company may require the return of any part claimed not to be as warranted to one of its facilities as designated by Company, transportation prepaid by Purchaser, to establish a claim under this warranty. Replacement parts provided under the terms of the warranty are warranted for the remainder of the Warranty Period.

NO WARRANTY IS MADE WITH RESPECT TO:

1. ANY PRODUCT WHICH HAS BEEN REPAIRED OR ALTERED IN SUCH A WAY, IN THE COMPANY’S JUDGMENT, AS TO AFFECT THE PRODUCT ADVERSELY
2. ANY PRODUCT WHICH HAS, IN THE COMPANY’S JUDGMENT BEEN SUBJECT TO NEGLIGENCE, ACCIDENT, IMPROPER STORAGE, OR IMPROPER INSTALLATION OR APPLICATION
3. ANY PRODUCT WHICH HAS NOT BEEN OPERATED OR MAINTAINED IN ACCORDANCE WITH THE RECOMMENDATIONS OF THE COMPANY
4. ANY RECONDITIONED OR PRIOR OWNED PRODUCT

STANDARD WARRANTY DISCLAIMER

THE FOREGOING WARRANTY IS EXCLUSIVE AND IT IS EXPRESSLY AGREED THAT, EXCEPT AS TO TITLE, THE COMPANY MAKES NO OTHER WARRANTIES AND HEREBY EXPRESSLY DISCLAIMS ALL OTHER WARRANTIES, INCLUDING WITHOUT LIMITATION, EXPRESSED, IMPLIED OR STATUTORY WARRANTIES, INCLUDING ANY IMPLIED WARRANTY OF MERCHANTABILITY OR FITNESS FOR A PARTICULAR USE. THE REMEDY PROVIDED UNDER THIS WARRANTY SHALL BE THE SOLE, EXCLUSIVE AND ONLY REMEDY AVAILABLE TO PURCHASER AND IN NO CASE SHALL THE COMPANY BE SUBJECT TO ANY OTHER OBLIGATIONS OR LIABILITIES. UNDER NO CIRCUMSTANCES SHALL THE COMPANY BE LIABLE FOR SPECIAL, INDIRECT, INCIDENTAL OR CONSEQUENTIAL DAMAGES, EXPENSES, LOSSES OR DELAYS HOWSOEVER CAUSED. NO STATEMENT, REPRESENTATION, AGREEMENT, OR UNDERSTANDING, ORAL OR WRITTEN, MADE BY ANY AGENT, DISTRIBUTOR, REPRESENTATIVE, OR EMPLOYEE OF THE COMPANY WHICH IS NOT CONTAINED IN THIS WARRANTY WILL BE BINDING UPON THE COMPANY UNLESS MADE IN WRITING AND EXECUTED BY AN OFFICER OF THE COMPANY. THIS WARRANTY SHALL NOT BE EFFECTIVE AS TO ANY CLAIM WHICH IS NOT PRESENTED WITHIN 30 DAYS AFTER THE DATE UPON WHICH THE PRODUCT IS CLAIMED NOT TO HAVE BEEN AS WARRANTED. ANY ACTION FOR BREACH OF THIS WARRANTY MUST BE COMMENCED WITHIN ONE YEAR AFTER THE DATE UPON WHICH THE CAUSE OF ACTION OCCURRED. ANY ADJUSTMENT MADE PURSUANT TO THIS WARRANTY SHALL NOT BE CONSTRUED AS AN ADMISSION BY THE COMPANY THAT ANY PRODUCT WAS NOT AS WARRANTED. WARRANTY IS NOT TRANSFERABLE

Gardner Denver®

For additional information, contact your local representative or visit:
www.contactgd.com/compressors

©2016 Gardner Denver, Inc. Printed in U.S.A.

