CHAMPION®

13-11-609
Version: 04
August 1, 2003

**ROTORCHAMP[®]
OIL-FREE ROTARY SCREW
COMPRESSORS**

MODELS

**RCOF (EWC99D)
20, 25 & 30 HP**

**OPERATING AND
SERVICE MANUAL**



MAINTAIN COMPRESSOR RELIABILITY AND PERFORMANCE WITH GENUINE CHAMPION® COMPRESSOR PARTS AND SUPPORT SERVICES

Champion Compressor genuine parts, manufactured to design tolerances, are developed for optimum dependability – specifically for Champion compressor systems. Design and material innovations are the result of years of experience with hundreds of different compressor applications. Reliability in materials and quality assurance is incorporated in our genuine replacement parts.

Your authorized Champion Compressor distributor offers all the backup you'll need. A worldwide network of authorized distributors provides the finest product support in the air compressor industry. Your local authorized distributor maintains a large inventory of genuine parts and he is backed up for emergency parts by direct access to the Master Distribution Center (MDC) in Memphis, Tennessee.

Your authorized distributor can support your Champion air compressor with these services:

1. Trained parts specialists to assist you in selecting the correct replacement parts.
2. Factory warranted new and remanufactured rotary screw airends. Most popular model remanufactured airends are maintained in stock at the Remanufacturing Center in Indianapolis, IN., for purchase on an exchange basis with liberal core credit available for the replacement unit.
3. A full line of factory tested RotorLub™ compressor lubricants specifically formulated for use in Champion compressors.
4. Repair and maintenance kits designed with the necessary parts to simplify servicing your compressor.

Authorized distributor service technicians are factory trained and skilled in compressor maintenance and repair. They are ready to respond and assist you by providing fast, expert maintenance and repair services.

For the location of your local authorized Champion Air Compressor distributor, refer to the yellow pages of your phone directory or contact:

Factory:
Champion
1301 N. Euclid Ave.
Princeton, IL 61356
Phone: (815) 875-3321
Fax: (815) 872-0421

REMANUFACTURED AIRENDS

Whenever an airend requires replacement or repair, Champion offers an industry unique, factory remanufactured airend exchange program. From its modern Remanufacturing Center in Indianapolis, IN., Champion is committed to supplying you with the highest quality, factory remanufactured airends that are guaranteed to save you time, aggravation and money.

Immediately Available

Repair downtime costs you money, which is why there are over 200 remanufactured units in inventory at all times, ready for immediate delivery.

Skilled Craftsmen

Our Remanufacturing assembly technicians average over 20 years experience with air compression products.

Precision Remanufacturing

All potentially usable parts are thoroughly cleaned, inspected and analyzed. Only those parts that can be brought back to original factory specifications are remanufactured. Every remanufactured airend receives a new overhaul kit: bearings, gears, seals, sleeves and gaskets.

Extensive Testing

Champion performs testing that repair houses just don't do. Magnaflux and ultrasonic inspection spot cracked or stressed castings, monochromatic light analysis exposes oil leaks, and coordinate measurement machine inspects to +/- .0001", insuring that all remanufactured airends meet factory performance specifications.

Warranty

Champion backs up every remanufactured airend with a new warranty...18 months from purchase, 12 months from service. Champion remanufactured airends deliver *quality without question...year in and year out.*
Call Champion for information on the airend exchange program and the name of your authorized distributor.

Phone Number: (815) 875-3321
Fax: (815) 872-0421

FOREWORD

Champion Rotary Screw compressors are the result of advanced engineering and skilled manufacturing. To be assured of receiving maximum service from this machine the owner must exercise care in its operation and maintenance. This book is written to give the operator and maintenance department essential information for day-to-day operation, maintenance and adjustment. Careful adherence to these instructions will result in economical operation and minimum downtime.



DANGER

Danger is used to indicate the presence of a hazard which will cause severe personal injury, death, or substantial property damage if the warning is ignored.



WARNING

Warning is used to indicate the presence of a hazard which can cause severe personal injury, death, or substantial property damage if the warning is ignored.



CAUTION

Caution is used to indicate the presence of a hazard which will or can cause minor personal injury or property damage if the warning is ignored.

NOTICE

Notice is used to notify people of installation, operation or maintenance information which is important but not hazard-related.

This book covers the following models:

HP	PSI	MODEL	PARTS LIST
20, 25, 30	100, 125, 150	RCOF (EWC99D	13-11-511

TABLE OF CONTENTS

Maintain Compressor Reliability And Performance With Genuine Champion Compressor Parts And Support Services	i
Remanufactured Airends	i
Foreword.....	ii
List Of Illustrations	iv
Section 1, General Information.....	1
Section 2, Installation, Coolers And Water Systems	5
Section 3, Starting & Operating Procedures	12
Section 4, Controls & Instrumentation.....	15
Section 5, Lubrication.....	38
Section 6, Air Filter.....	40
Section 7, Belt Drive.....	42
Section 8, RO Water Filtration System	44
Section 9, Maintenance Schedule.....	51
Section 10, Troubleshooting	54
Section 11, Troubleshooting Auto Sentry W Controller.....	56
Section 12, Troubleshooting The RO Filtration System.....	62

LIST OF ILLUSTRATIONS

Figure 1-1 – Typical Compression Cycle	1
Figure 1-2 – Package Illustration.....	2
Figure 1-3 – Air/Water Schematic	3
Figure 2-1 – Typical Compressor Room	6
Figure 2-2 – Air Flow Chart	6
Figure 2-3 – Inlet Line Lengths.....	8
Figure 2-4 – Grease Recommendations	11
Figure 2-5 – Regreasing Interval	11
Figure 4-1 – Auto Sentry W Controller Display	17
Figure 4-2 – Flow Chart For Setup Programming	20
Figure 4-3 – Auxiliary Pressure Switch/Receiver Unloaded Pressure Tabulation	31
Figure 4-4 – Wiring Diagram – Full Voltage.....	34
Figure 4-5 – Wiring Diagram – Full Voltage Less Starter.....	36
Figure 5-1 – Oil Level Sight Glass.....	39
Figure 6-1 – Heavy Duty Air Filter (Standard).....	40
Figure 7-1 – Belt Tension 3VX Belts.....	43
Figure 8-1 – PLC Connections And Cycle Time Combinations	47

SECTION 1 GENERAL INFORMATION

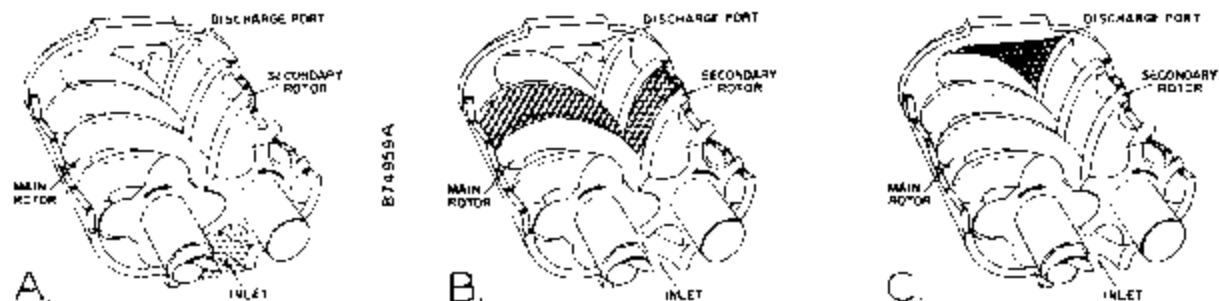

Figure 1-1 – TYPICAL COMPRESSION CYCLE

COMPRESSOR - The Champion Rotary Screw compressor is a single stage, positive displacement rotary machine using meshing helical rotors to effect compression. Both rotors are supported between high capacity roller bearings located outside the compression chamber. Single width cylindrical roller bearings are used at the inlet end of the rotors to carry part of the radial loads. Angular contact ball bearings at the discharge end locate each rotor axially and carry all thrust loads and the remainder of the radial loads.

COMPRESSION PRINCIPLE (Figure 1-1) - Compression is accomplished by the main and secondary rotors synchronously meshing in a one-piece cylinder. The main rotor has six (6) helical lobes 60° apart. The secondary rotor has eight (8) matching helical grooves 45° apart to allow meshing with main rotor lobes.

The air inlet port is located on top of the compressor cylinder near the drive shaft end. The discharge port is at the bottom on the opposite end of the compressor cylinder.

Figure 1-1 is an inverted view to show inlet and discharge ports. The compression cycle begins as rotors unmesh at the inlet port and air is drawn into the cavity between the main rotor lobes and secondary rotor grooves (A). When the rotors pass the inlet port cutoff, air is trapped in the interlobe cavity and flows axially with the meshing rotors (B). As meshing continues, more of the main rotor lobe enters the secondary rotor groove, normal volume is reduced and pressure increases.

Water is injected into the cylinder to remove the heat of compression and seal internal clearances. Volume reduction and pressure increase continues until the air/water mixture trapped in the interlobe cavity by the rotors passes the discharge port and is released to the air/water reservoir (C). Each rotor cavity follows the same “fill-compress-discharge” cycle in rapid succession to produce a discharge air flow that is continuous, smooth, and shock free.

AIR FLOW IN THE COMPRESSOR SYSTEM (Figure 1-3, page 3) - Air enters the air filter and passes through the inlet unloader valve to the compressor. After compression, the air/water mixture flows to the separator/reservoir tank where most of the water is removed by velocity change and impingement. The air flows to the aftercooler, then to the moisture separator where the water that has condensed out is removed from the air stream. The air then flows through the package discharge check valve and to the plant air system.

WATER SYSTEM (Figure 1-3, page 3) - Water is forced by air pressure from the separator/reservoir tank through the heat exchanger, the system water filter and into the water injection manifold where the water is distributed to the compression chamber injection ports. The water removes the heat of compression and seals internal clearances. Seals minimize water leakage out of the compression chamber.

LUBRICATION - Oil in the oil reservoir at the discharge end of the airend lubricates the discharge end bearings. Grease fittings are located at the inlet end of the airend for periodic lubrication of the inlet end bearings.

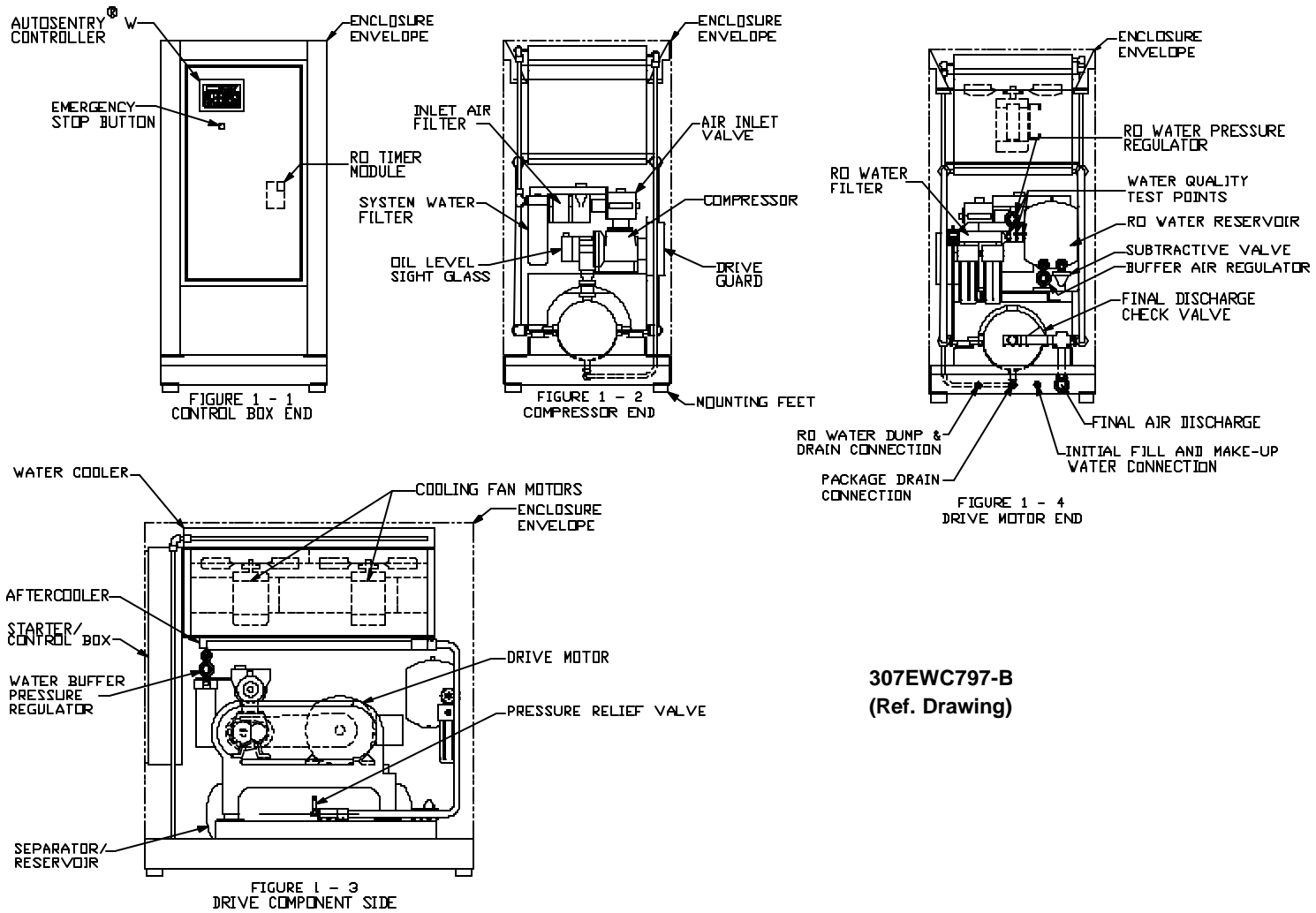

307EWC797-B
(Ref. Drawing)

Figure 1-2 – PACKAGE ILLUSTRATION

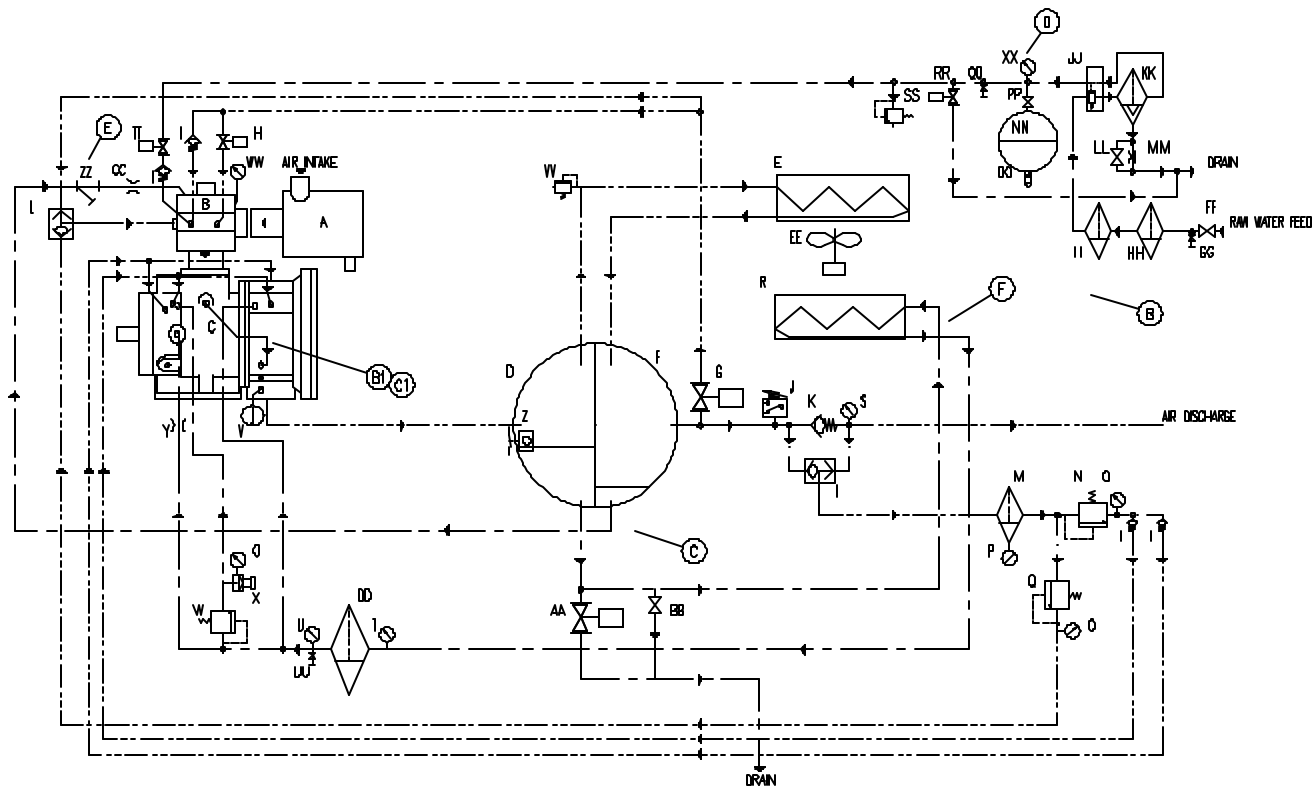

- | | | | |
|---|-----------------------------------|----|---|
| A | AIR FILTER | AA | SOLENOID VALVE (RESERVOIR WATER DRAIN) |
| B | INTAKE POPPET VALVE | BB | VALVE BALL (RESERVOIR WATER DRAIN) |
| C | COMPRESSOR | CC | VALVE BALL (CONDENSATE DRAIN) |
| D | WATER SEPARATOR | DD | SOLENOID VALVE (CONDENSATE DRAIN) |
| E | AIR COOLERS | EE | FILTER (AUXILIARY WATER) |
| F | CONDENSATE SEPARATOR | FF | COOLING FANS |
| G | SOLENOID VALVE (MAIN BLOWDOWN) | GG | SOLENOID VALVE (RAW WATER FEED) |
| H | SOLENOID VALVE (AUX. BLOWDOWN) | HH | SOLENOID VALVE (RAW WATER TEST PT) |
| I | CHECK VALVE | II | FILTER (SEDIMENT) |
| J | PRESSURE SWITCH (AUX. RD VALVE) | JJ | FILTER (CARBON) |
| K | CHECK VALVE (PACKAGE) | KK | BACKPRESSURE REGULATOR (RD SHUTOFF) |
| L | SHUTTLE VALVE | LL | NO (PREVENT OILLOSS) FILTER |
| M | AIR FILTER / COND. SEPARATOR | LL | VALVE BALL (RD FAST FLUSH) |
| N | AIR PRESSURE REGULATOR | NN | SOLENOID VALVE (RD WATER FEED) |
| O | PRESSURE GAUGE (LOCAL 0-15#) | NN | SOLENOID VALVE (RD WATER TEST PT) |
| P | AUTOMATIC DRAIN VALVE | OO | SOLENOID VALVE (RESERVOIR AIR MEMBRANE) |
| Q | SUBSTRACTIVE VALVE | PP | SOLENOID VALVE (RESERVOIR ISOLATION) |
| R | WATER COOLER | QQ | SOLENOID VALVE (RD WATER TP) |
| S | XOUCER PRESSURE TAP (SYSTEM) | RR | SOLENOID VALVE (RD WATER DUMP) |
| T | XOUCER PRESSURE TAP (RESERVOIR) | SS | SOLENOID VALVE (RD WATER DUMP) |
| U | XOUCER PRESSURE TAP (INJECTION) | TT | SOLENOID VALVE (RD WATER DUMP) |
| V | XOUCER TEMP (COMP DISCH) | UU | SOLENOID VALVE (RD WATER DUMP) |
| W | PRESSURE REGULATOR (BUFFER WATER) | VV | SOLENOID VALVE (RD WATER DUMP) |
| X | PUSH-ON SWITCH (CHECK ISOLATION) | WW | SOLENOID VALVE (RD WATER DUMP) |
| Y | DRIKKE (WATER INJECTION) | XX | SOLENOID VALVE (RD WATER DUMP) |
| Z | LEVEL SWITCH ASSY (WATER) | YY | SOLENOID VALVE (RD WATER DUMP) |
| | | ZZ | SOLENOID VALVE (RD WATER DUMP) |

--- WATER LINES
 - - - AIR LINES

308EWC797-F
 (Ref. Drawing)

Figure 1-3 – AIR/WATER SCHEMATIC

SAFETY PRECAUTIONS

Safety is everybody's business and is based on your use of good common sense. All situations or circumstances cannot always be predicted and covered by established rules. Therefore, use your past experience, watch out for safety hazards and be cautious. Some general safety precautions are given below:



DANGER

Failure to observe these notices could result in injury to or death of personnel.

- **Keep fingers and clothing away** from revolving fan, drive coupling, etc.
- **Do not use the air discharge** from this unit for breathing – not suitable for human consumption.
- **Do not loosen or remove** the oil filler plug, drain plugs, covers the thermostatic mixing valve or break any connections, etc., in the compressor air or oil system until the unit is shut down and the air pressure has been relieved.
- **Electrical shock** can and may be fatal.
- **Perform all wiring** in accordance with the National Electrical Code (NFPA-70) and any applicable local electrical codes. Wiring and electrical service must be performed only by qualified electricians.
- **Open main disconnect switch**, tag and lockout before working on the control.
- **Disconnect the compressor unit** from its power source, tag and lockout before working on the unit – this machine is automatically controlled and may start at any time.



WARNING

Failure to observe these notices could result in damage to equipment.

- **Stop the unit** if any repairs or adjustments on or around the compressor are required.
- **Disconnect the compressor unit** from its power source, tag and lockout before working on the unit – this machine is automatically controlled and may start at any time.
- **An Excess Flow Valve** should be on all compressed air supply hoses exceeding 1/2 inch inside diameter (OSHA Regulation, Section 1926.302).
- **Do not exceed** the rated maximum pressure values shown on the nameplate.
- **Do not operate unit** if safety devices are not operating properly. Check periodically. Never bypass safety devices.
- **Do not disconnect** the compressor unit from its power source for more than two days. During normal operation or fouling, reverse osmosis of the membrane may occur. Refer to your Operating and Service manual for details concerning the reverse osmosis water filtration system.

SECTION 2 INSTALLATION, COOLERS AND WATER SYSTEMS

GENERAL - On receipt of the unit, check for any damage that may have occurred during transit or handling. Report any damage or missing parts as soon as possible.



CAUTION

Do not electric weld on the compressor or base; bearings can be damaged by passage of current.

LIFTING UNIT - Proper lifting and/or transporting methods must be used to prevent damage. Tow motor fork clearance is provided by the equipment isolators bolted to the base of the unit. The unit may also be moved into location by rolling on bars.



CAUTION

Lift compressor unit by base only. Do not use other places such as motor, compressor or discharge manifold piping as lifting points.



DANGER

The eyebolts or lugs provided on the motor are for lifting the motor only and should not be used to lift any additional weight. All eyebolts must be securely tightened. When lifting the motor, the lifting angle must not exceed 15 degrees. Failure to observe this warning may result in damage to equipment or personal injury.

LOCATION - The compressor should be installed in a clean, well-lighted, and ventilated area with ample space all around the unit for maintenance. Select a location that provides a cool, clean, and dry source of air. In some cases it may be necessary to install the air filter at some distance from the compressor to obtain proper air supply.



WARNING

Do not install this compressor in a location that may be subject to temperatures below 32° F. (0° C).

Below freezing temperatures will cause damage to the compressor.

The air-cooled unit requires cooling air as well as air to the compressor inlet. Proper ventilation **MUST** be provided; hot air must be exhausted from the compressor operating area. A typical inlet-outlet air flow arrangement is shown in Figure 2-1, page 6.

Air-Cooled Units - An air cooled heat exchanger and aftercooler is supplied as standard equipment on all air-cooled units. The air cooled motors and fans are mounted within the cooling module; air is drawn into the enclosure through louvers in the side panels, through the aftercooler and exhausted through the

heat exchanger at the top of the unit. The air-cooled unit with the standard enclosure requires sufficient flow, Figure 2-2, page 6, for the compressor water/aftercooling system and for electric motor cooling. Do not block the air flow to and from the unit. Allow three and one-half (3-1/2) feet to the nearest obstruction on the control box end of the unit. Allow three (3) feet to the nearest obstruction above and on other sides of unit. For continuous efficiency, the heat exchanger and aftercooler cores must be periodically cleaned with either vacuum or compressed air. If wet cleaning is required, shield the motor and spray on a mild soap solution, then flush with clean water.

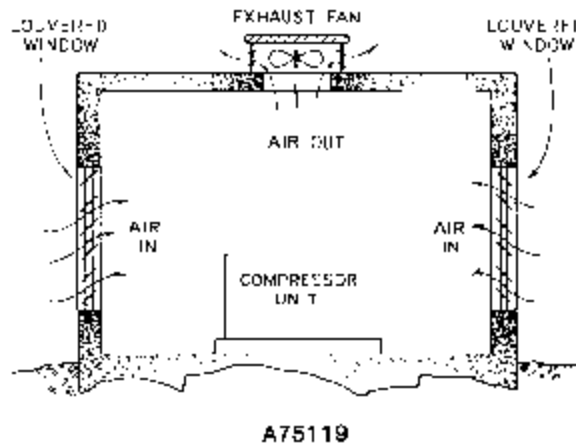



Figure 2-1 – TYPICAL COMPRESSOR ROOM

Minimum Air Flow * For Compression and Cooling Cubic Feet/Minute (Cubic Meters/Minute)	
HP (kW)	Air Cooled
20 – 30 (15 – 22)	5,200 (147)

* 80° F (27° C) Inlet Air

Figure 2-2 – AIR FLOW CHART

 WARNING
<p>For copper water coolers, do not use any cleaning solution that is not compatible with copper. Use of improper solution may result in damage to the cooler.</p>

FOUNDATION - The Champion Rotary Screw compressor requires no special foundation, but should be mounted on a smooth, solid surface. Whenever possible, install the unit near level. Temporary installation may be made at a maximum 10° angle lengthwise or 10° sidewise.

Mounting bolts are not normally required. However, installation conditions such as piping rigidity, angle of tilt, or danger of shifting from outside vibration or moving vehicles may require the use of mounting bolts and shims to provide uniform support for the base.

OIL RESERVOIR DRAIN - The oil drain plug is located at the bottom of the discharge end of the compressor. (See Figure 5-1, page 39.)

ENCLOSURE - The compressor, electric motor, water cooler and aftercooler are mounted inside the enclosure.

Service doors are provided for maintenance access. Be sure to allow enough space around the unit for the doors to be opened and removed as necessary for service procedures. The enclosure doors are held by two latches and lift away from the enclosure. The air filter, water filters, and water treatment cartridge are easily accessible through a side or end door.



DANGER

Do not operate the compressor with the belt guard removed. Exposed belts may cause injury to personnel.

COMPRESSOR WATER SPECIFICATION - The compressor unit is supplied with an integral filtration system (by reverse osmosis) to ensure adequate quality levels for the injection water system. In order to maintain the water filtration system working at peak efficiency, the incoming water supply must meet a number of requirements. Please refer to the "RO Water Filter", Section 8, of this manual for details.



WARNING

Back flow Preventers must be installed on the potable water supply line to the compressor to prevent high pressure air from blowing into the water supply.



WARNING

Use of compressor initial fill and make-up water not meeting all water specification standards noted may result in contamination of the discharge air stream.



WARNING

The use of make-up water exceeding the quality units outlined in the “RO Water filter”, Section 8, may result in damage to critical compressor components by corrosion and/or scaling action of impurities in the water.

NOTICE

Water may no longer be potable after use in the compressor.

AUXILIARY AIR RECEIVER - An auxiliary air receiver is not required if the piping system is large and provides sufficient storage capacity to prevent rapid cycling. When used, an air receiver should be of adequate size, provided with a relief valve of proper setting, a pressure gauge and a means of draining condensate. A system with adequate volume would produce consecutive compressor unload cycles of no less than 30 seconds.

MOISTURE SEPARATOR/ORIFICE- Since the unit is equipped with a built-in aftercooler, an integral moisture separator and drain trap is furnished with the unit. The moisture from the trap is piped to the compressor inlet flange.

INLET LINE - Where an inlet line is used between the air filter and the compressor, it must be thoroughly cleaned on the inside to prevent dirt or scale from entering the compressor. **If welded construction is used, the line must be shot blasted and cleaned to remove welding scale.** In either case, the inlet line must be coated internally by galvanizing or painting with a moisture and oil-proof sealing lacquer. Up to ten (10) feet in length, the inlet line should be the full size of the inlet opening on the compressor. If an extra-long line is necessary, the pipe size should be increased according to “Inlet Line” chart, Figure 2-3, page 8.

Accessibility for inlet air filter servicing must be considered when relocating the filters from the unit to a remote location.

Length of Inlet Line	Diameter of Pipe Size
0 to 10 Feet (0 to 3 Meters).....	Same as Compressor Inlet Opening
10 to 17 Feet (3 to 5 Meters).....	One size Larger Than Inlet Opening
17 to 38 Feet (5 to 11.5 Meters).....	Two Sizes Larger Than Inlet Opening

Figure 2-3 – INLET LINE LENGTHS

DISCHARGE SERVICE LINE - The discharge service line connection on the unit is made from the right side at base level from the motor end of the package. When manifolding two or more rotary screw units on the same line, each unit is isolated by the check valve in the unit discharge line. If a rotary screw unit is manifolded to another compressor, be sure the other compressor has a check valve in the line between the machine and the manifold. If a rotary screw and reciprocating compressor are manifolded together, an air receiver must be located between the two units.



DANGER

Discharge air used for breathing will cause severe injury or death. Consult filtration specialists for additional filtration and treatment equipment to meet health and safety standards.

The oil-free air discharging from the RCOF package is saturated with water vapor at discharge temperature. An air dryer may be required if the air is used in a moisture sensitive process. In addition, the compressed air may be mixed with atmospheric contaminants entering the intake of the compressor.

UNIT WATER DRAIN - The unit drain ports should be connected to a floor drain(s). Drain line(s) must slope downward, away from the unit, to allow effluent to flow by gravity, and must be vented to the atmosphere to avoid the accidental back flow of said effluent into the package. As necessary, the automatic water management system will open the drain solenoid valve to drain excess water. Since the drain solenoid valve may open at any point during compressor operation, high temperature water under pressure may be discharge from the unit. During operation, a small, steady stream of wash water is normally discharged by the water treatment filter via the drain port.



DANGER

Hot water under pressure will cause severe personal injury or death. Do not operate compressor until a water drain line is installed from compressor water drain port to a floor drain.

AIR/WATER RESERVOIR WITH INTEGRAL MOISTURE SEPARATOR - The air/water reservoir-separator combines multiple functions into one vessel. On one end of the vessel, the lower half functions as a reservoir, providing water storage capacity for the system and the upper portion serves as primary air/water separation. The reservoir also provides limited air storage for control and gauge actuation. Secondary moisture separation is achieved downstream of the aftercooler on the other end of the vessel.

COMPRESSOR INJECTION WATER SYSTEM CHECK - The following readings are based on an ambient temperature of 80° F inlet cooling air on air-cooled units with the cooling system in good, clean condition. The compressor should be at operating temperature at the time of the checks. One-half hour of loaded operation is usually sufficient to reach level-out operating temperatures.

Air and Water Discharge Temperature - 105° F to 125° F - Read on the “AUTO SENTRY W” control panel.

Compressor Injection Water Inlet Temperature - 90° F to 110° F - Check anywhere on the line from the heat exchanger to the compressor inlet.

Water Injection Cooler Temperature Differential (Air Cooled Heat Exchanger) - The water temperature differential depends on the temperature of the air at the water injection cooler fan and the cleanliness of the core faces. As ambient temperatures and core restrictions increase, the injection water outlet temperature will increase. The injection water outlet temperature is approximately the same as the package exhaust air temperature. The outlet temperature may be checked by installing a tee in the water line between the separator/reservoir and the cooler.

Water Injection Cooler Pressure Differential (Air Cooled Heat Exchanger) - 5 to 7 psid - Check injection water pressure differential in the same place as temperature. (See above.)

ELECTRICAL WIRING - Standard Units - The Twistair® compressor is factory wired for all starter to motor and control connections for the voltage specified on the order. It is necessary only to connect the unit starter to the correct power supply. The standard unit is supplied with an open drip-proof motor, a NEMA 12 starter and control enclosure. See “Location” paragraph, page 5, for distance to nearest obstruction on starter and control box sides of the unit.



WARNING

Electrical shock can cause injury or death. Open main disconnect switch, tag and lockout before working on starter/control box.

GROUNDING - Equipment must be grounded in accordance with Section 250 of the National Electrical Code.



WARNING

Failure to properly ground the compressor package could result in controller malfunction.

MOTOR LUBRICATION - Long time satisfactory operation of an electric motor depends in large measure on proper lubrication of the bearings. The charts below show recommended grease qualities and regreasing intervals for ball bearing motors. For additional information, refer to the motor manufacturer's instructions.

The following procedure should be used in regreasing:

1. Stop the unit.
2. Disconnect, tag and lockout the unit from the power supply.
3. Remove the relief plug and free hole of hardened grease.
4. Wipe lubrication fitting clean and add grease with a hand-operated grease gun.
5. Leave the relief plug temporarily off. Reconnect the unit and run for about 20 minutes to expel the excess grease.
6. Stop the unit. Replace the relief plug.
7. Restart the unit.

⚠	WARNING
Rotating machinery can cause injury or death. Open main disconnect, tag and lockout power supply to the starter before working on the electric motor.	

ELECTRIC MOTOR GREASE RECOMMENDATION (-30° C TO 50° C)

Manufacturer	Trade Name
Chevron	SRI #2
Shell	Dolium R
Exxon	Unirex #2
Exxon	Polyrex

Figure 2-4 – GREASE RECOMMENDATIONS

ELECTRIC MOTOR REGREASING INTERVAL

Type of Service	Typical Examples	Rating	Relubrication Interval
Standard	One or Two-Shift Operation	Up to 150 HP (112 kW)	18 Months
		Above 150 HP (112 kW)	12 Months
Severe	Continuous Operation	Up to 150 HP (112 kW)	9 Months
		Above 150 HP (112 kW)	6 Months
Very Severe	Dirty Locations, High Ambient Temperature	Up to 150 HP (112 kW)	4 Months
		Above 150 HP (112 kW)	2 Months

Figure 2-5 – REGREASING INTERVAL

SECTION 3 STARTING & OPERATING PROCEDURES

PRESTART-UP INSTRUCTIONS - A new unit as received from the factory has been tested and then prepared for shipping. Do not attempt to operate the unit until checked and serviced as follows:

1. **Compressor Oil** - Check airend oil level. The normal oil level is in the center of the sight glass. Oil level must be within the operating range. Add or drain oil to correct level using the same type of oil. (See Figure 5-1, page 39).



DANGER

Air and water under pressure will cause severe personal injury or death. Shut down compressor, relieve system of all pressure, disconnect, tag and lockout power supply to the starter before removing valves, caps, plugs, fittings, bolts and filters.



CAUTION

Use of improper lubricants will cause damage to equipment. Do not mix different types of lubricants or use inferior lubricants. See Section 5, page 38, for lubrication recommendations.

NOTICE

Regular maintenance and replacement at required intervals of the air and water filters are necessary to achieve maximum service of this screw compressor. Use only genuine Champion filters designed and specified for this compressor.

2. **Air Filter** - Inspect the air filter to be sure it is clean and tightly assembled. Refer to Section 6, page 40, for complete servicing instructions. Be sure the inlet line, if used, is tight and clean.
3. **Piping** - Refer to Section 2, "Installation", page 5, and make sure piping meets all recommendations.
4. **Electrical** - Check the wiring diagrams furnished with the unit to be sure it is properly wired.
5. See Figure 4-4 and Figure 4-5, pages 34 and 36, for general wiring diagrams and Section 2, page 5, for installation instructions.

6. **Grounding** - Equipment must be grounded in accordance with Section 250 of the National Electrical Code.



WARNING

Failure to properly ground the compressor package could result in controller malfunction.

7. **Rotation** - Check for correct motor rotation using “JOG MODE.” An arrow on the compressor/motor belt guard shows correct rotation. Compressor drive shaft rotation must be counterclockwise standing facing the compressor sheave.



WARNING

Operation with incorrect motor rotation can damage equipment and cause water eruption from the compressor inlet. When checking motor rotation, induce minimum rotation (less than one revolution if possible). Never allow motor to reach full speed.

8. **System Pressure** - Set the controls to the desired unload and load pressures. **DO NOT EXCEED MAXIMUM OPERATING PRESSURE ON COMPRESSOR NAMEPLATE.** See Section 4, “Controls and Instrumentation”, for procedure.



WARNING

Operation at excessive discharge air pressure can cause personal injury or damage to equipment. Do not adjust the full discharge air pressure above the maximum stamped on the unit nameplate.

9. **Operating Mode** - Refer to Section 4 for detailed information on the control system.
10. **Enclosure** - Check for damaged panels or doors. Check all screws and latches for tightness. Be sure doors are closed and latched.

11. **Initial Water Fill/Adjusting RO Timer** - You package is shipped with all water drained. The water receiver must be filled with filtered water (reverse osmosis filter) prior to operating the compressor unit:

- Ensure that the make-up water feed line is installed and the ball valve is open.
- Engage the Emergency Stop button to avoid accidental operation of the compressor.
- Disconnect package from electrical power.
- Select a suitable water fill cycle – see RO Filter System, Section 8, for details on operating and adjusting the PLC and its timing operation. Under normal conditions, the 4 hour-fill cycle would be adequate. Note the current (or desired) running cycle setting on the PLC – it must be reset after completing the filling operation.
- Reconnect package to electrical power.
- Toggle PLC “run/stop” mode switch off and on to reset the timer and start the selected fill cycle. After the “on” (fill) cycle times out, the “off” (rest) cycle will follow. If necessary, the mode switch can be cycled at any time to reset the timer and re-start a new fill cycle.
- After the tank is filled to the proper level (half-way up the reservoir-mounted sight tube), disconnect electrical power, and reconnect the original (or desired) running timer cycle settings on the PLC.
- Re-connect package to electrical power and disengage the Emergency Stop button.

STARTING THE UNIT - Start the unit by pushing the [RUN] key. The unit will reach normal operating temperature in approximately 5 minutes. Check the package operating information by pressing the [INFO] key or keypad cursor [<] [>] keys at any time during unit operation.

DAILY CHECK - Refer to Section 9, “Maintenance Schedule”, page 51.

STOPPING THE UNIT - Press [STOP/RESET] key. The air/water reservoir will automatically blow down as the motor stops.

SECTION 4

CONTROLS & INSTRUMENTATION

GENERAL DESCRIPTION - The Champion Twistair water-flooded rotary screw compressor is prewired with all controls, motor, and starter for the voltage and horsepower at the time of ordering. It is necessary only to connect the compressor unit to the correct power supply, to the shop air line, and to the appropriate water supply. A standard compressor unit consists of the compressor, water reservoir, water cooling system and filters, lubrication reservoir, motor type as specified, NEMA 12 starter/control box, and control components as described below.

This compressor unit features the AUTO SENTRY W controller, which integrates all the control functions under microprocessor control. Its functions include safety and shutdown, compressor regulation, operator control, and advisory/maintenance indicators. The keypad and display provide the operator with a logical and easily operated control of the compressor and indication of its condition.

AUTO SENTRY W OPERATION

Normal operation is controlled by the keys in the OPERATE island of the AUTO SENTRY W controller. Prior to starting, press the [STOP/RESET] key to place the controller into its READY state (as indicated on the display). Press the [RUN] key to start the compressor. The green LED will light near the automatic operation symbol whenever operation is enabled.

The [STOP/RESET] key may be pressed at any time to stop the compressor under normal conditions. If the compressor has been running, the reservoir pressure is relieved before stopping the motor. The display will count down to zero during the normal stop.

An optional control may be wired into the AUTO SENTRY W controller to interrupt and restart the unit based on controls by others. When stopped by these controls, the display indicates remote stop.



WARNING

Automatic restarting or electrical shock can cause injury or death. Open, tag and lockout main disconnect and any other circuits before servicing the unit.

In any mode, the compressor will start only if reservoir pressure is below 5 psig (0.3 bars). The display will indicate if the control is waiting for a reservoir blowdown, along with the remaining pressure. The controls also delay initial loading of the compressor until a startup delay has been completed.

All modes of operation provided by the AUTO SENTRY W controller produce load/unload flow control. An independent pneumatic pilot valve is also supplied to provide flow modulation and thus match package air supply to the system demand. If simple load/unload operation is desired, the pneumatic pilot valve can be deactivated by setting its opening pressure beyond the unload pressure setting programmed in the controller. See "Subtractive Valve", page 31, under "Other Control Devices" for details.

Constant Run Mode Operation - This mode is best used in applications where there are no long periods of unloaded operation. The compressor unit will start and run continuously, using its controls to load and unload the compressor. This matches average delivery to demand. When the air demand is less than the compressor capacity, the air pressure rises to the unload point of the controller, which will then unload, blow down, and stop delivery of air to the system. Air demands are supplied by air stored in receivers and plant piping. When the pressure falls halfway between the unload and load pressures, the W controller again fully loads the compressor.

When first starting, the controller will keep the compressor fully unloaded and blown down until the system pressure drops below the load pressure.

Low Demand Mode Operation - This mode is similar to the “Continuous Run” mode, except for its behavior under unloaded conditions. If the blowdown timer has completed its cycle when the next unload operation takes place, the controller will not reload the package until the line pressure has reached the “load” level. Otherwise, if the blowdown timer is still active, the machine will reload the package when the line pressure falls halfway between the “unload” and “load” levels.

Automatic Mode Operation - This mode provides automatic start and timed stop, and is best used in applications with long unloaded periods and adequate storage to allow the compressor to be stopped for periods of light demands. Operation during periods of moderate to heavy demands is identical to the low demand and constant run modes described above.

The automatic time delay is adjustable from 5 to 20 minutes. If the controller operates unloaded for this period with no demand, the compressor drive motor is halted to eliminate its power consumption. The controls will remain in this state until pressure drops below the load pressure.

This is the most common selected mode of operation, as it automatically will operate the compressor unit in the most efficient manner for the demand of the air system.

When packages are sequenced and rotated, it is not recommended to engage the pneumatic pilot valves for flow modulation. See “Subtractive Valve”, page 31, under “Other Control Devices” for details.

Sequence Mode Operation - This mode provides for communication between controllers, operating only as many as are required for economical operation. This is best used on applications with large storage capacity and diverse loads. The lead unit will operate identically to the automatic mode; operation will be automatically staged for each lag unit (up to 8 total). For more information, refer to the sequencing instructions later in this chapter.

An optional expansion board must be installed for sequencing operation. Communication between controllers is achieved by interconnection of a communications cable to expansion board connectors. A “unit number” must be assigned to each unit in this mode, but the display will indicate the unit’s actual operating ranking.

AUTO-SENTRY W CONTROL DISPLAY

The display above the keypad is used to provide operating information to the user. If a shutdown has occurred, the display will indicate the cause.

During normal operation, the display will show the system pressure, compressor discharge temperature, total running hours, and operation mode. Alternate displays are available by pressing the [?] INFO or the keypad cursor [<] [>] keys, and will be identified on the display. These include:

Water Filter Differential Pressure	DIF PRES
Reservoir Pressure	RES PRES
Water Injection Pressure	INJ PRES
System Pressure	SYS PRES
Compressor Discharge Temperature	DIS TMP
Total Hours	TOT HRS
Loaded Hours	LOAD HRS
Remaining Blowdown Time	BD TMR
Remaining Auto Time	AUTO TMR

Remaining blowdown and auto times are only available in Low Demand, Automatic, and Sequence modes, as appropriate.

If no keys are pressed for 5 seconds, the display will revert to its normal mode.

The display is also used as a service reminder for normal maintenance items. If service is recommended, the yellow LED next to the service symbol will come on, and a message will alternate with the normal lower line message. These messages are intended to advise of conditions which may lead to a shutdown.

If a protective shutdown occurs, the red LED next to the shutdown symbol will be on and the top line of the display will indicate "SHUTDOWN." The lower line will indicate the cause of the shutdown.

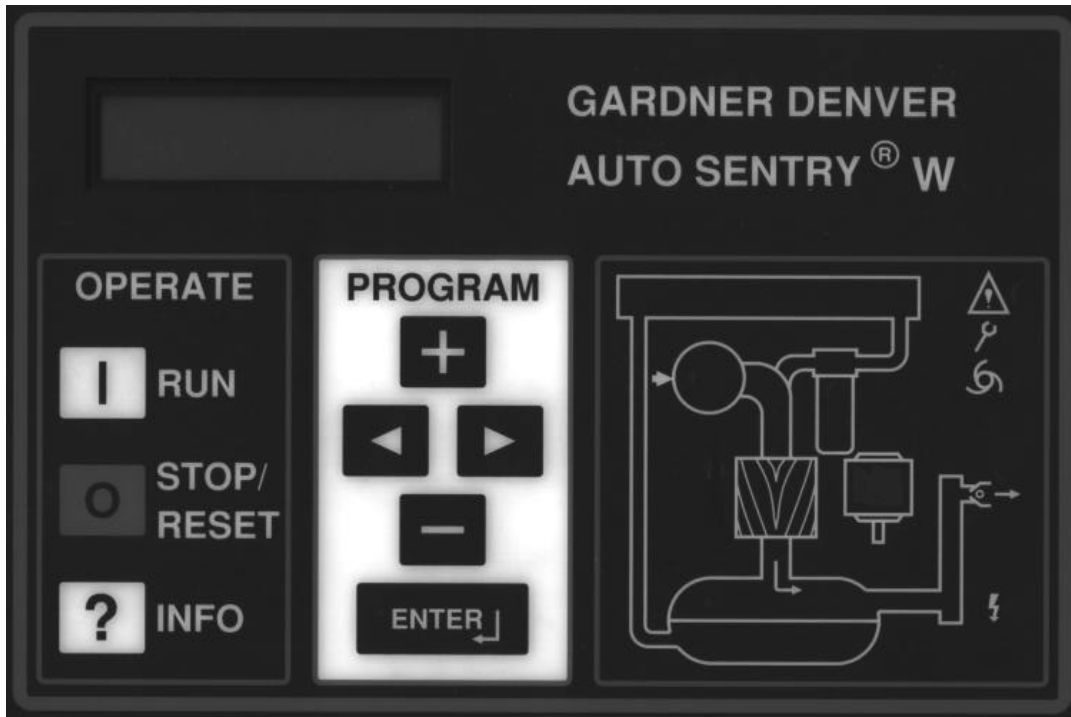

Figure 4-1 – AUTO SENTRY W CONTROLLER DISPLAY

SERVICE ADVISORIES

The AUTO SENTRY W controller turns on an advisory when it detects operation which needs service attention, but does not warrant shutting down the compressor. Some of these are normal maintenance procedures, and are intended to serve as a reminder to perform routine service. Others are conditions which can reduce the maximum compressor performance. It will remain in effect until reset. Check the display during routine inspections, and perform maintenance as suggested. Refer to the troubleshooting section for detailed information about each advisory.

Temperature advisories may be cleared while the unit is running by simply pressing the [ENTER] key. To reset the service advisories, press the [STOP/RESET] key to stop operation of the compressor. After it has stopped, disconnect power and service as required. After servicing, restore power and reset the controller as indicated in the programming / maintenance section below.

PROTECTIVE SHUTDOWNS

The AUTO SENTRY W will shut down the unit following any fault detected in the following devices. Long-term problems will have a brief blowdown period before fully shutting down. Following a shutdown, a message will be displayed, with the top line indicating "SHUTDOWN" and the lower line indicating the cause. The shutdown light will be steadily lit while the shutdown condition is present, or will flash if the condition no longer exists. Refer to the troubleshooting section for detailed information about each shutdown. To resume operation, the cause of the shutdown must be corrected and the controller reset by pressing the [STOP/RESET] key.

Motor Protective Devices - Overload heaters are furnished for the starter in the voltage range specified. There are three (3) overloads in the starter of proper size for the starter and its enclosure. Note that motor nameplate current must be multiplied by 0.577 for Wye-Delta starters. The display will indicate that an overload relay has tripped. The overload relay is reset by pressing the button on the relay itself, then the controller may be reset. Motor current (amps) and voltage must be measured in the affected motor wiring to locate the cause for high current. Proper starter coil and contact action is also monitored and errors in operation will cause a shutdown with the cause displayed as a starter or contact error.

High Temperature - The compressor is protected from high discharge temperature by a thermistor probe located in the compressor discharge. The AUTO SENTRY W will shut the compressor down if temperature exceeds 190° F (88° C) (or lower per user adjustment) or if rapid temperature rise is detected. Shutdown will also occur if the temperature falls below freezing. The thermistor probe is also checked for open or shorted circuits, and the display will indicate a fault, if found.



CAUTION

Machine damage will occur if compressor is repeatedly restarted after high temperature stops operation. Find and correct the malfunction before resuming operation.

Water Filter Differential Pressure - The pressure drop across the water filter is continually monitored by the AUTO SENTRY W. The unit will be shut down at a differential pressure of approximately 40 psid (2.8 bars). This becomes active only after the compressor has been running and pressures have had time to stabilize.

The pressure drop can be monitored at any time by selecting the alternate display "DIF PRES" (water filter differential pressure) with the [?] HELP key. This should be checked while the compressor is delivering at full capacity. A service advisory comes on to recommend maintenance prior to this shutdown.

High Water Level - If the water management controls are unable to maintain proper water levels, the compressor will shutdown to prevent damage. Check wiring and piping of the drain and fill solenoid valves. A shutdown also occurs if wiring errors are detected in the float switch, and the display will indicate a bad float switch.

High Pressure - The AUTO SENTRY W will first attempt to unload and blow down the unit if excessive pressures are detected in the reservoir or the plant system. If unsuccessful, a shutdown will occur. Shutdown will also occur if a defective transducer is detected. The display will indicate the location of the high sensed pressure or transducer (xducer) error. Check that all adjustments have been properly made, and all connections are secure.

Emergency Stop - Press the emergency stop button to shut down the unit and the controller. To restart, pull the button out to its normal position and reset the controller. This should be used for emergency purposes only - use the keypad [STOP/RESET] for normal controlled stopping.

Power Failure - Following power interruptions, the controller will remain in a shutdown state (unless programmed for auto restart).

External Device - This input is provided for user- or dealer- installed devices needed by specific applications. Other shutdown field selectable messages include: high vibration, phase relay, low voltage relay, and water press. An optional expansion board must be installed to use this feature.

Other Shutdowns - The controller runs continuous diagnostic checks of its own operation and the sensors to which it is connected. Refer to the service section for a complete listing of shutdowns and remedial actions.

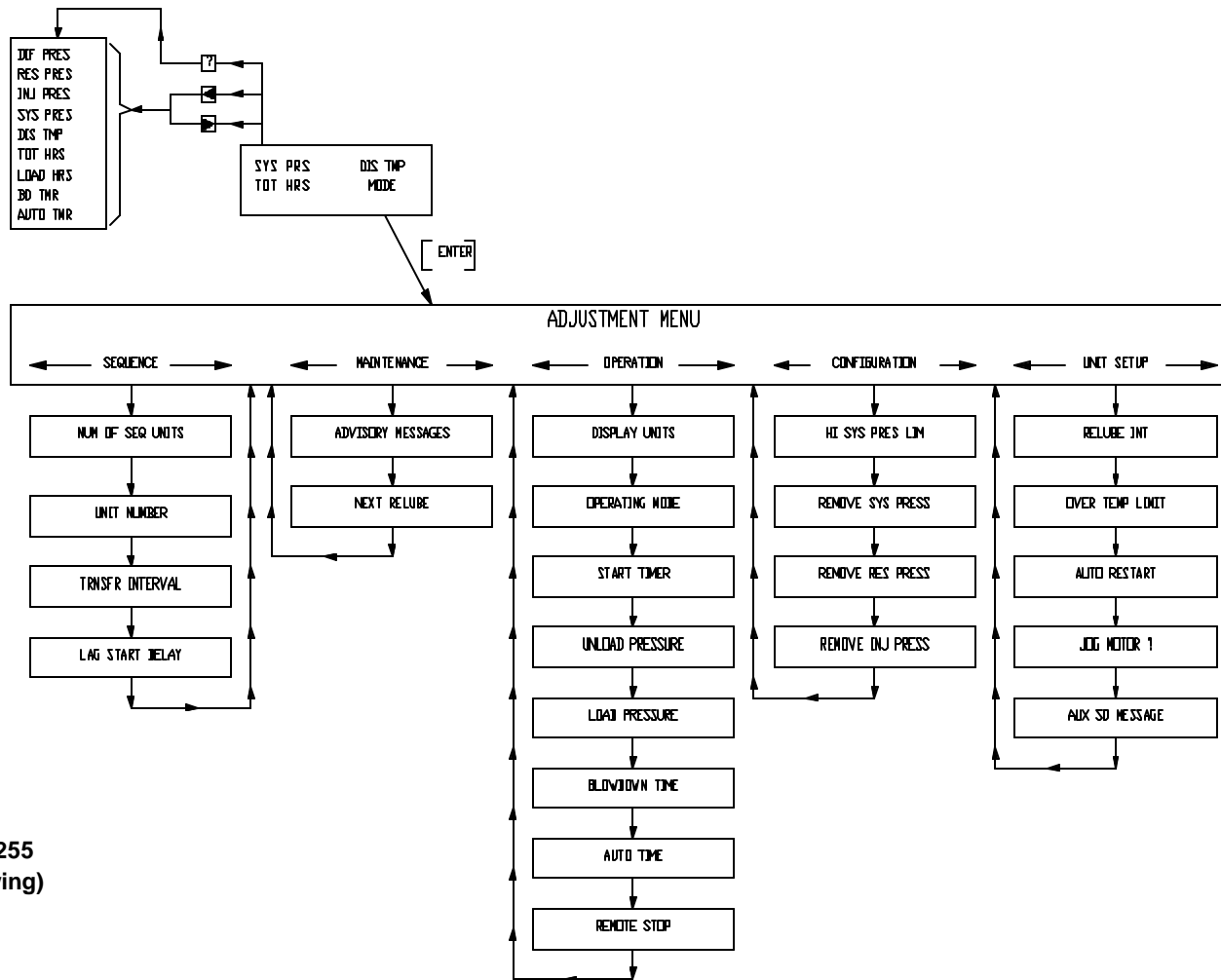

300EWC1255
(Ref. Drawing)

Figure 4-2 – FLOW CHART FOR SETUP PROGRAMMING

PROGRAMMING AND SETUP FOR THE AUTO SENTRY W CONTROLLER

Programming and setup is accomplished with the PROGRAM keys. See Figure 4-2, page 20. In all steps, the [ENTER] key will cause the controller to accept the displayed value into memory and advance to the next programming function. The plus [+] and minus [-] keys will increase and decrease displayed numeric values, or step through menu selections. During numeric adjustments, the right [>] and left [<] arrow keys move the cursor (flashing digit) to the position desired. Use the [+] and [-] keys to change the number at the cursor. At any point in the programming and setup routine, the [STOP/RESET] key can be pressed to exit and return to the ready mode without altering the adjustment. In all steps of the programming routine, the top line of the display will give a description of the parameter to be programmed, while the bottom line shows the variable that is capable of being altered by programming.

The following is a step by step guide to programming the AUTO SENTRY W. Remember, between each step, it is necessary to press the [ENTER] key to store the new value and advance to the next step.

Main Adjustments Menu

1. The compressor must be stopped prior to making any adjustments. If the unit is running, press the [STOP/RESET] key to place the control in the "READY" state.

Adjustments can also be performed while in the "SHUTDOWN" state. After the adjustments are completed, the W controller returns to this state until the cause is repaired and the controller is manually reset.
2. Press the [ENTER] key to begin programming. This enters the adjustments menu. The adjustments are broken into five groups as shown in Figure 4-2, page 20. To select a group, press [+] or [-] until the desired group is shown on the bottom line of the display. Press [ENTER] to proceed to the group adjustments detailed below.

Operation Adjustments

1. In the top line, "**DISPLAY UNITS**" is indicated. The bottom line will indicate "ENGLISH" (PSIG, Fahrenheit) or "METRIC" (Bars, Celsius) units of measurement. Select the desired display units and press [ENTER] to proceed.
2. The top line displays, "**OPERATING MODE**". The bottom line will indicate the selected mode. Refer to the description of modes at the beginning of this chapter, and select the desired mode, using the [+] or [-] keys. When the desired mode is shown, press the [ENTER] key to save and proceed.
3. In the top line, "**START TIMER**" is displayed. The bottom line will indicate a time between 2 and 10 seconds. This is the time that the controller spends in the unloaded 'start' mode. If reduced-voltage starting is used, it should be set longer than the starter's timer.
4. In the top line, "**UNLOAD PRESSURE**" is displayed. The bottom line will indicate a pressure value. It is to be set at the nameplate rating of the compressor for normal operation. Under NO circumstances, is this adjustment to be set in excess of the compressor nameplate pressure.
5. In the top line, "**LOAD PRESSURE**" is displayed. The bottom line will indicate a pressure value. This setting determines the point at which machine startup occurs in AUTO and SEQUENCE modes and when the compressor will load up from the blown down condition. Note that LOAD PRESSURE cannot be set within 7 PSI of the UNLOAD PRESSURE. It is necessary that all machines to be sequenced have the same UNLOAD and LOAD PRESSURE setpoints.

6. In the top line, **"AUTO TIME"** is displayed. The bottom line will indicate a time between 5 and 20 minutes. It too, is factory set at 10 minutes. Its function is to prevent too frequent motor starting, and to allow the motor a 'cool-down' period before stopping.
7. In the top line, **"REMOTE STOP"** is displayed. The bottom line indicates either "TIMED" or "IMMEDIATE". Refer to the description of "Remote On/Off" later in this section for additional details. Select the desired response to the remote input and press [ENTER] to proceed.
8. This completes the operational adjustments. The controller will return to the main adjustments menu.

Maintenance Adjustments

1. If any service advisories are in effect (yellow ADVISORY indicator is on), they will be displayed on the top line. The bottom line indicates **"LEAVE ADVISORY"** (do not reset) or **"CLEAR ADVISORY"** (turn it off). Select the desired action and press [ENTER] to proceed.
2. The top line displays **"NEXT RELUBE"** and the hours remaining are displayed on the bottom line. Press the [+] or [-] keys to switch to the lubrication change interval (see UNIT SETUP) if service was performed early. Press [ENTER] to proceed.
3. This completes the maintenance adjustments. The controller will return to the main adjustments menu.

Sequence Adjustments

See "SEQUENCING COMPRESSORS WITH THE AUTO SENTRY W, page 24, for more details on setting up and optimizing a sequenced compressor installation.

1. In the top line, **"NUM OF SEQ UNITS"** is displayed. The bottom line will indicate a number in the range of one through eight. This will be factory set at "1". This should be set to a number corresponding to the number of compressors that are currently installed on this air system that also have AUTO SENTRY W controllers. It should be noted that all AUTO SENTRY W compressors on the system must have the same number programmed here to operate correctly in SEQUENCE mode. Adjust as required, and press [ENTER] to proceed.

NOTICE

<p>Setting the value in Step 1 to one indicates that no sequencing is to take place. Consequently, Steps 2, 3 & 4, which relate to sequencing, are skipped by the AUTO SENTRY W; the controller will return to the main adjustments menu.</p>
--

2. In the top line, **"UNIT NUMBER"** is displayed. The bottom line will again indicate a number of one through eight and be factory set at "1". Each AUTO SENTRY W in a sequenced system must have a unique number here. The sequence mode will not function if two or more compressors have the same UNIT NUMBER. The most efficient machine-to-machine communications will occur when the lowest possible numbers are used. Example: 1, 2, and 3 for a three compressor installation.

All other settings should normally be the same for all units.

3. In the top line, "**TRANSFER INTERVAL**" is displayed. The bottom line will indicate a number of hours in the range of 1 to 5000. It is factory set at 24. This is the number of hours that this machine will stay in the role of "master" or "lead" compressor.

Normally it is desirable to set this to the same value on all sequenced units to equalize running hours. Different values may be programmed, if desired, to help equalize hours.

4. In the top line, "**LAG START DELAY**" is displayed. The bottom line will indicate a number in the range of 15 to 600 seconds. It is factory set at 30. This is the length of time this machine will wait before starting when the pressure drops below the load point. This should be set to the same value for all sequenced units. Its setting will depend on the amount of air storage volume in the system. Too small a number will result in more compressors being started than is necessary to satisfy the demand.
5. This completes the sequence adjustments. The controller will return to the main adjustments menu.

Configuration Adjustments

1. In the top line, "**HI SYS PRES LIM**" is displayed. The bottom line will indicate a value that is factory set 20 - 25 PSI above name plate. This is the pressure that will cause a shutdown if exceeded due to a malfunction such as a stuck inlet valve or broken control line. This should be set at or slightly below the rating of the pressure relief valve. The controller will attempt a number of actions as it approaches to prevent the pressure from reaching this limit.
2. In the top line, "**REMOVE SYS PRESS**" is displayed. The bottom line displays the current pressure being sensed at the package discharge. At this point, steps must be taken to ensure that system pressure is, in fact, zero psig. Remove the line to the system pressure transducer. Pressing [ENTER] will now cause the AUTO SENTRY W to calibrate the transducer output to zero PSIG. Obviously, pressure measurement errors will be encountered if 'zeroing' is done with pressure at the transducer. If large errors are detected, the controller will demand that the transducer be checked.
3. In the top line, "**REMOVE RES PRESS**" is displayed. The bottom line displays the current pressure being sensed in the reservoir. The reservoir pressure transducer may now be 'zeroed' by following the steps outlined in 2 above.
4. In the top line, "**REMOVE INJ PRESS**" is displayed. The bottom line displays the current pressure being sensed in the water line. The water injection pressure transducer may now be 'zeroed' by following the steps outlined in #2 above.
5. This completes the configuration adjustments. The controller will return to the main adjustments menu.

Unit Setup Adjustments

1. In the top line, "**RELUBE INTERVAL**" is displayed. The bottom line will indicate a time interval of 1000 to 2000 hours. After the machine has run for the programmed setting, an advisory will be displayed, requesting relubrication. Adjust as desired and press [ENTER] to proceed.
2. In the top line, "**OVER TEMP LIMIT**" is displayed. The bottom line will indicate 190° F. This is the maximum (and proper) setting for compressor operation. It may be temporarily lowered to verify the function of the temperature shutdown system.

3. In the top line, "**AUTO RESTART**" is displayed. The bottom line will indicate either "OFF" or "ON". The factory setting is "OFF", and the controller will display a power failure shutdown after power has been restored.

Set this feature to ON when it is necessary to have the compressor automatically restart after a power interruption. There will be a brief delay, then the control resumes the mode it was in prior to the interruption. This feature shall only be enabled when the owner determines that it is safe to do so. It is recommended that compressor access be limited to only trained service personnel when this feature is used.

4. This step is only encountered if the AUTO RESTART function was set to ON in the previous step. In the top line, "**RESTART DELAY**" is displayed. The bottom line will indicate a time between 5 and 60 seconds. It is factory set at 10 seconds. This is the amount of delay introduced before restarting after power has been restored. Set it as desired to allow for power to stabilize before starting compressors.
5. The display now reads "**JOG MOTOR?**" and indicates the amount of time to energize the starter. Adjust with the [+] or [-] key to the smallest value needed to bump the motor and check rotation. 0.1 to 0.2 seconds is normally adequate for factory-furnished full-voltage starters; Wye-Delta or remote starters may require a little more time. Set back to zero to proceed to the next step.
6. In the top line, "**AUX SD MESSAGE**" is displayed. The bottom line will display the message which will appear if power is removed from the shutdown input on the optional expansion board. Select the most appropriate message for user-furnished shutdown devices, and press [ENTER] to proceed.
7. This completes the unit setup adjustments. The controller will return to the main adjustments menu.

OTHER CONTROL FEATURES

Auto restart after power failure - The AUTO SENTRY W controller normally displays "SHUTDOWN - POWER FAILURE" after power has been interrupted and restored. Press the [STOP/RESET] key and select an operating mode to restart the compressor.

If programmed for automatic restart, the controller pauses and begins counting down when power is restored. This time is adjustable in the programming steps noted above. This must be at least several seconds, but may be set longer to allow other plant loads to start up first. After the countdown is complete, the controller resumes the mode of operation prior to the power interruption.

When auto restart is enabled, the green power indicator will blink whenever power is on. With auto restart disabled, the power indicator lights steadily while power is on.

SEQUENCING COMPRESSORS WITH THE AUTO SENTRY W

An accessory expansion board, part number 301EWC1173, is required in each controller for sequencing operation. This is included with any package ordered with wye-delta starters, and may be ordered separately and installed on other packages. Refer to expansion board connection instructions later in this section.

Sequencing compressors with the AUTO SENTRY W controller is as simple as plugging in a telephone to a wall jack. The only item required to make the system functional is a standard telephone cable identical to cables that connect nearly every telephone to its wall jack. One less cable than the number of compressors to be sequenced is required. For example, to sequence four compressors, three cables are required. A kit, 200EAP752, is available which contains all material needed to sequence up to five compressors. This kit contains 500 feet of cable, eight modular connectors, and a crimping tool to install the connectors.

In spite of its inherent installation simplicity, the sequencing function of a multi-compressor AUTO SENTRY W system provides all the necessary features for maintaining pressure over a wide range of plant demands.

Installation

A proper sequencing installation requires two or more Champion rotary air compressors complete with AUTO SENTRY W controllers, piped into a common air system, interconnected as described above. For best performance, the units must be piped directly to the receiver, without any intervening check valves, dryers, or other restrictions. The receiver should also be sized to prevent excessive drops or rapid rises in pressures during the operation as described below. All standard practices common to sound air compressor installations such as proper sizing of discharge piping, proper electrical supply and conductor sizing, and grounding are to be observed. The serial communications interface meets RS-485 standards, the most widely used interface in harsh, industrial environments today. However it is still recommended that the communications cables be routed through metallic conduit to provide them with both mechanical protection and electromagnetic shielding.

Each expansion circuit board has two modular jacks which accept RJ-12 telephone plugs. One jack is vacant, the other has a short pigtail plugged into it. To interconnect two compressors, plug the cable into the vacant jack on each controller. For installations of more than two units, the pigtail plug must be disconnected on all controllers except the two at each end of the communications line. The order of interconnection has no effect on the system operation. The following conditions are necessary and sufficient for proper operation:

1. Every compressor must have a cable connecting it to another compressor. One less cable than the number of units sequenced must be used.
2. Each board that has only one cable connected to it must have its pigtail plugged into the unused jack. All installations will have two such units.

Operation

1. ESTABLISHING THE INITIAL SEQUENCE

Operation of compressors in sequence requires only selection of the sequence operating mode during adjustments and a press of the [RUN] key on each compressor in the system. Since the sequencing algorithm includes provisions for automatic replacement of a failed master or 'lead' compressor, it is important for the operator to be aware of the hierarchy of events when starting the system.

The first compressor placed into sequence mode will become the master. However, since any compressor first placed into sequence has no way of knowing whether or not a master exists, it will first assume the highest rotation number available. For example if the number of units to be sequenced is programmed at four, any compressor will start out in position four when placed in sequence mode. It will then listen on the communications line for a call from the master.

If no call is received, it will assume position three and again wait for a call from the master. After another lack of a master call, it assumes position two. Subsequently, it assumes position one which makes it the master. As soon as a master is established, it immediately attempts to call all other units and assigns them successive rotation positions. The system is now active.

Before a master is established, the system is not deprived of air. This is due to one of the outstanding features of the AUTO SENTRY W sequencing system: pressure control is always executed locally at each individual compressor. The effective unload point for compressor control is the programmed unload point minus 3 (rotation number - 1). So while compressors count down towards establishing a master, they are also capable of delivering air at a pressure determined by the above formula.

To ensure that two or more machines do not simultaneously decrement their rotation numbers and simultaneously become masters, it is advisable to place the desired master in sequence mode first and wait until the first decrement in rotation number is seen (about 7 seconds) before placing subsequent compressors in sequence mode. If it is desired to dictate the complete initial sequence manually, wait until the previous machine decrements one position and then place the next desired compressor in sequence mode. If it is acceptable to let the master determine the initial sequence, simply wait until the master has decremented its rotation number once, and then place all remaining compressors in sequence mode. Remember that once a master is established, no further self-decrementing is done by the individual compressors. Instead, they will wait until the master assigns them a rotation number.

Rotation numbers are displayed in the bottom display line, with the mode indication. For example, the mode indication for the current master is SEQ1; for the first lag compressor, SEQ2; second lag, SEQ; etc.

2. HOW THE "AUTO SENTRY W" CONTROLS PRESSURE WHILE SEQUENCING

Each compressor operates exactly the same as if it were in AUTO mode with one exception: it has a dynamic unload point. The initial unload point is determined by the equation shown above. A compressor is started when the system pressure drops below its programmed load point, after waiting for ['LAG START INTERVAL' times (rotation number - 1)] seconds. This prevents all lag compressors from starting at once. Note that a compressor's ['LAG START INTERVAL' times (rotation number - 1)] timer is not reset to zero until that compressor is started or until another unit in the system stops. This means that the time for the next lag compressor to come on may be somewhat less than 'LAG START INTERVAL'.

EXAMPLE:

In a three compressor sequence system, UNLOAD PRESSURE = 100 PSI; LOAD PRESSURE = 90 PSI; LAG START INTERVAL = 15 seconds. The lead compressor is running alone, maintaining 90-100 PSI when an air tool is brought on line causing the air demand to exceed the capacity of the lead compressor. When the pressure drops to 90 PSI, the #2 unit times out its 15 second timer and starts. It takes 5 additional seconds for the pressure to rise above 90 PSI. The #3 unit whose timer was initially set at 30 seconds (15 x [3 - 1]), has counted down 20 seconds (the total time that system pressure was below 90 PSI). If air demand increases again, the pressure will have to fall below 90 PSI for only 10 seconds more to start unit #3.

As was previously stated, a lag compressor's unload point (PSET for short) is [UNLOAD PRESSURE - 3(rotation number - 1)]. Thus in the above example, the first lag compressor (rotation #2) has a PSET of 97 PSI; the second lag, 94 PSI, and so on. But look what happens in an eight compressor installation: The eighth compressor will have an initial unload point of [100 - 3(8 - 1)], or 79 PSI. Does this mean that an eight compressor installation must operate 21 PSI below the desired operating point when all compressors are running? NO! This is where the AUTO SENTRY W dynamic unload point control takes over.

This is how it works: Whenever the system pressure is below the programmed LOAD PRESSURE, the PSET of each lag compressor is incremented 1 PSI every thirty seconds. Thus, after a short interval (about five minutes in this example), the PSET of the last sequenced compressor will climb up until either it equals the LOAD PRESSURE, or a decrease in demand causes the actual system pressure to rise above the LOAD PRESSURE. It can be seen then, that except for short periods just after a sudden increase in demand, the AUTO SENTRY W, with its dynamic unload point control, will maintain system pressure between the limits of LOAD PRESSURE and UNLOAD PRESSURE. Remember, LOAD and UNLOAD PRESSURE values are programmed by the operator so the operating range is completely programmable and predictable.

Dynamic unload point control will also work in reverse of the operation described above. Obviously, incrementing unload points will cause overlap of the compressors' modulation ranges. While this enables us to maintain a higher pressure than competitor's sequencers, overlap is undesirable as demand decreases, because a system could end up with several compressors cycling instead of running the minimum number of fully loaded compressors. To overcome this, as pressure rises through the range between LOAD and UNLOAD, the lag compressors' set points are now decremented, reversing the effect described above during periods of high demand. The AUTO SENTRY W keeps track of all functions at all times so there is never any mix-up of unload points and the proper rotation sequence is always maintained.

The Automatic Sequence Change

After the master (lead) compressor has served for the duration programmed (TRANSFER INTERVAL), it relinquishes control and assigns itself the highest available rotation number. The lag compressors detect the loss of the master and decrement their rotation numbers. Number 2 becomes number 1, the new master, number 3 becomes number 2, etc.

It should be noted also that whenever the master detects a missing rotation number, such as when a compressor is turned off that was previously in the rotation, it will automatically 'close the gap' by decrementing the rotation numbers of all compressors whose rotation numbers were greater than the missing number. Likewise, if for whatever reason, the master compressor fails to carry out its role, all lag compressors begin decrementing their rotation number until a new master is established. Regardless of the scenario, the end result will always be that the compressors that remain in rotation will always end up with the lowest possible rotation numbers.

Other Features

Any air system will exhibit pressure differences from one point to the next. Even a well designed multi-compressor installation will show 'minor' pressure variations between one compressor's discharge point and another compressor's discharge. These points will also vary from the central system (normally the air storage receiver). The AUTO SENTRY W sequencing system is designed to tolerate minor variations. These pressure differences wreak havoc with conventional sequencers. If a central sequencer is used, it will be sensing a lower pressure than is seen at each compressor. With such systems, there is always a chance that the sequencer could cause a compressor to over pressure due to this pressure drop. The alternative has been to set the central sequencer to a lower pressure to prevent this or allow local override of the sequencer by the local pressure control, neither of which is desirable in the scheme of maintaining plant pressure efficiently with sequencing. The AUTO SENTRY W sequencing system will automatically adjust the system to prevent over pressures in any individuals.

The AUTO SENTRY W sequencing system lets each compressor control itself independently between setpoints derived to cause staggered operation, or sequencing. The aforementioned pressure drops can also cause derogatory effects (mainly skewed, or out of sequence operation) to the sequencing algorithm used by the AUTO SENTRY W.

Since these pressure variations are not constant (they will vary due to demand changes, compressor load / unload changes, and number of compressors running), any scheme to compensate for the pressure variations must be dynamic. The exclusive dynamic unload point control feature enables this error correction scheme to be accomplished rather easily.

Here's how it works: The master continually receives system pressure values from every machine in the sequence rotation. The values are averaged and this average is then distributed to all lag compressors. All compressors, lead and lag, then compare their local pressure reading to the average and adjust their PSET by the amount of error. The effect is that all compressors are controlling to a single pressure reading, a reading that is not one that is picked up somewhere removed from the compressor, but an average of actual discharge pressures.

It should be noted that the pressure displayed on the top line by all sequenced compressors is this average.

CONNECTION OF EXPANSION BOARD AND EXTERNAL CONTROL CIRCUITS

The AUTO SENTRY W controller has a connection port for use with an expansion board, part number 301EWC1173. This provides interconnection points for external controls and indicators. This allows simple connection to remote controls and indicators, or integration into any plant wide controls system. The expansion board also provides the data port for communications in sequencing. The expansion board is pre-installed on any unit with factory-mounted Wye-Delta starters.

To install on other units, stack the expansion board over the main control board, and mount with the hardware included. Use the cable to connect the expansion board to the main board. The AUTO SENTRY W controller automatically detects the presence or absence of the expansion board, but 120V input circuits must be connected to the expansion board for proper operation. Spare terminals are provided at the control terminal strip in the box for connection of the following 120v circuits. Connect either to unused existing terminals, or mark blank terminal locations for new points shown.

Connect from the expansion board plug to terminals as follows:

Expansion Plug	Panel Terminal
J1-1	8 (existing)
J1-2	no connection
J1-3	23 (new)
J1-4	24 (new)
J1-5	10 (existing)
J1-6	21 (new)
J1-7	20 (new)
J1-8	19 (new)

Remote On / Off - Remote on-off control of the system requires only a simple two-wire control, with an isolated contact suitable for 120 volts, 1 amp. This may be a switch, a timer contact, a relay contact, or a PLC output. To connect, simply run the two wires to the control enclosure, remove the jumper (if present) between terminal 9 and 31, and connect the pair of wires from the switch to terminals 9 and 31.

The air compressor will operate normally in its selected mode whenever this contact is closed (turned on). Note that the keypad is always the master control; the [RUN] key must be pressed to place the control into an operating mode. The remote is not capable of starting a unit after the [STOP/RESET] key has been pressed to place the controller in the READY state. When the contact is opened (turned off), operation depends on how the controller has been programmed and what it is doing prior to opening the contact.

If the compressor was already stopped in automatic or sequence modes, it will remain stopped and will not restart until the contact is closed. The display will flash the message "REMOTE STOP" to indicate that it is waiting for the remote signal.

If the compressor was running in any mode when the contact was opened, and the remote response is programmed for "IMMEDIATE", the compressor will immediately unload and blowdown. After completion of blowdown, the motors will stop, and the unit will be in the "REMOTE STOP" mode as indicated above.

If the compressor was running in any mode when the contact was opened, and the remote response is programmed for "TIMED UNLOAD", the compressor will immediately unload and blowdown. It will then continue to run unloaded for whatever period has been programmed for "AUTO TIME" (or will complete the remaining auto time if already blown down). After completion, the motors will stop, and the unit will be in the "REMOTE STOP" mode as indicated above. This is the preferred setting for automatic remote controls which may cycle in less than 1/2 hour, as the motor is always cooled evenly and rapid start cycles are prevented.

If remote control is not desired, this input must be jumpered to operate the compressor. Connect a jumper between terminals 9 and 31.

Auxiliary Shutdown - This input allows factory or field connection of shutdown switches not included on the standard package. Simply connect a two-wire switch to terminals 9 and 31. The switch must be selected which has contacts closed for normal conditions, and open to shutdown the compressor. If the contact is opened, the compressor will be shut down, and will display a user selectable message (refer to unit setup adjustments for list of messages).

If no additional switch is desired, this input must be jumpered to operate the compressor. Connect a jumper between terminals 9 and 24.

Alarm Relay - The expansion board is provided with an alarm relay which may be connected to a remote mounted indicator light, horn, or into a PLC input of a plant wide control system. The contact is commercial rated 2 amps at 120 volts. The relay is turned on whenever there is a shutdown condition requiring service at the compressor, and remains off during normal operation, stopping, or power off conditions. The external connections from the controller are from an isolated form C (single-pole, double-throw) contact. This allows control of either a "compressor okay" or a "compressor shutdown" remote indicator.

To use this relay, connect the supply wire for the remote circuit to terminal 21 (relay common) on the terminal strip. Connect a wire to the indicator from either terminal 19 (normally open) or from terminal 20 (normally closed). Connect the other side of the indicator to its neutral.

OTHER CONTROL DEVICES

In addition to the electronic controller noted above, the following components are also used to control operation of the compressor unit. Refer to air/water schematic, Figure 1-3, page 3, for their relative location.

Relief Valve (vv) - A pressure relief valve is installed in the final discharge line and set to approximately 120-125% of the unit's full load operating pressure for protection against over pressure. Periodic checks should be made to ensure its operation.

The relief valve should be tested for proper operation at least once every year. To test the relief valve, raise the system operating pressure to 75% of the relief valve set pressure and manually open the valve with the hand lever. Hold the valve open for a few seconds and allow it to snap shut.



WARNING

When the relief valve opens, a stream of high velocity air is released, resulting in a high noise level and possible discharge of accumulated dirt or other debris. Always wear eye and ear protection and stand clear of the discharge port when testing the relief valve to prevent injury.



CAUTION

Never paint, lubricate or alter a relief valve. Do not plug vent or restrict discharge.



WARNING

Operation of unit with improper relief valve setting can result in severe personal injury or machine damage. Insure properly set valves are installed and maintained.

Blowdown Valve (g) - This solenoid valve provides purging air to the compressor during unloaded operation. It also depressurizes the air/water reservoir during unloaded or halted operation. It is governed by the AUTO SENTRY W controller.

Aux. Blowdown Valve (h) - This solenoid valve depressurizes rapidly the air/water reservoir during the initial phase of the unloading cycle. It is energized by the auxiliary pressure switch.

Aux. Pressure Switch (j) - This device senses the air reservoir pressure and controls the closing level of the auxiliary blowdown valve during the latter phase of the unloading cycle. Its setting (see Figure 4-3, page 31) is adjusted to maintain the compressor inlet pressure within 0 to 11" Hgv during unloaded operation. It is housed in the starter control box, but it is independent from the AUTO SENTRY W controller.

Model Power – bhp	20	20	20	25	25	25	30	30	30
Line Pressure – psig	100	125	150	100	125	150	100	125	150
Receiver Pressure – psig	41	32	26	46	40	32	51	48	37

Figure 4-3 – AUXILIARY PRESSURE SWITCH/RECEIVER UNLOADED PRESSURE TABULATION

Check Valve (Aux Blowdown) (i, next to b) – This check valve prevents back flow of air from the airend immediately after halting operation.

Check Valve (Main Discharge) (k) – This check valve prevents back flow of air from the customer’s air line when the unit stops, unloads, or is shut down.

Inlet Valve (b) – This device modulates the flow of air entering the compressor and checks the back flow of air immediately after halting compressor operation. Its piston assembly is energized with air from the subtractive valve (during modulation) or with air from the main blowdown valve (during unloaded operation).

Subtractive Valve (q) – This device produces a variable pneumatic signal (0 to 20 psig) in proportion to a system pressure rise (0 to 10 psig) above its set pressure. It is used to control the flow modulating action of the inlet valve. The device is adjusted as follows:

- Loosen the locknut securing the adjusting stem of the subtractive valve and screw the latter in several turns – this will prevent the valve from opening during adjustment. This is also the way to deactivate the device by adjusting its pressure setting beyond the expected package operating range.
- Operate the compressor until the desired discharge pressure is achieved – in case the supply of air exceeds the demand, bleed some of the discharge air to achieve the target system pressure.
- Back-out the adjustment stem until the subtractive valve starts to bypass air – the adjacent pressure gauge should register movement of less than 1 psig. Now the device is ready to feed a proportional air signal to the inlet poppet valve as the system pressure builds beyond the present level.
- Tighten the lockout to secure the position of the adjustment stem.

The subtractive valve can be disassembled and the diaphragm and ports cleaned.

Water Pressure Relief Valve (ss) – This device protects the water treatment filtration system against 75 psig overpressure in the line common with the compressor inlet.

Air Pressure Regulator (All Seal Purge) (n) - This device regulates the pressure of the air buffer signal fed to all seals. It should be set to 5 to 7 psig.

Water Pressure Regulator (Inlet Seal Purge) (w) - This device regulates the pressure of water buffer signal fed to the inlet seals. It should be set to 2 to 3 psig.

Pressure Gauge (o) – This 0 to 15 psig device displays the output signal from the pressure regulators.

Shuttle Valve (l) - Also known as a double check valve, the shuttle valve is a device which will take two (2) supply signals and allow the one with the highest pressure to pass through.

System Pressure Transducer (s) - This device measures the delivery air pressure supplied to the customer. The AUTO SENTRY W controller uses this measurement for loading/unloading logic. It is located in the starter enclosure.

Reservoir Pressure Transducer (t) - This device measures the discharge pressure from the water cooler. The AUTO SENTRY W controller uses this measurement to prevent loaded starts and to monitor coolant pressure. It is located in the starter enclosure.

Injection Pressure Transducer (u) - This device measures the recirculation water filter discharge pressure, prior to injection into the compressor. The AUTO SENTRY W controller uses this measurement, in conjunction with that from the reservoir pressure transducer, to monitor the pressure losses across the recirculation water filter. The AUTO SENTRY W controller displays a service warning at 30 psig differential and shuts the package down at 40 psig differential. It is located in the starter enclosure.

Air Filter Vacuum Switch (ww) - This device senses the air pressure at the discharge side of the air filter. The AUTO SENTRY W controller displays a service warning when a 25" H₂O pressure level triggers the switch. It is located in the starter enclosure.

Discharge Thermistor (v) - This device measures the compressor discharge temperature. The AUTO SENTRY W controller uses this measurement for display and shutdown logic purposes. It is located at the compressor discharge port.

Water Level Switches (z) - This assembly (three level switches) senses water level in the reservoir. The AUTO SENTRY W controller uses the individual signals to drain or fill the reservoir with water and to shut the system down if an exceedingly high water level prevails.

Water Solenoid Valves (aa, rr, tt) - The fill (tt) and drain (aa) valves respond to the signal from the water level switches to fill or drain, respectively, water from the main reservoir. The dump (rr) valve responds to signals from the PLC to dump the water charge stored in the water treatment reservoir when the compressor unit is not operating.

PLC (RO timer function) - This device governs the frequency and duration of the water-fill cycles. It shares use of the fill water solenoid valve with the AUTO SENTRY W controller and governs the dump water solenoid valve. It is located in the starter enclosure. Refer to the RO Filtration System, SECTION 8, for details on its operation and adjustments.

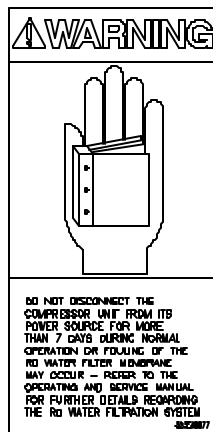

Emergency Stop/Push Button - This is a maintained push-button, and removes power from the controller outputs regardless of controller status. It is located on the upper section of the panel, next to the keypad. This should be used for emergency purposes only - use the keypad [STOP/RESET] for normal controlled stopping.



WARNING

Automatic restarting or electrical shock can cause injury or death. Open, tag and lockout main disconnect and any other circuits before servicing the unit.

Control Transformer - This changes the incoming power voltage to 110-120 volts for use by all unit control devices. Two primary and one secondary fuse are provided. Refer to adjacent labeling for replacement information.

Terminal Strip - This provides connections for all 110-120 volt devices not contained within the enclosure.

Fan Starter - The starter is used to provide control and overload protection for the fans. Overload heaters should be selected and adjusted based on the motor nameplate amps and the instructions located inside the cover of the electrical enclosure.

Main Starter - This starter is used to provide control and overload protection for the main drive motor. Full voltage starters employ a single contactor. Overload heaters should be selected and adjusted based on the motor nameplate amps and the instructions located inside the cover of the enclosure. Wye-Delta starters employ three contactors which are controlled sequentially to provide low current starting. For Wye-Delta starters, the motor nameplate amps must be first multiplied by 0.577 before using the heater table.

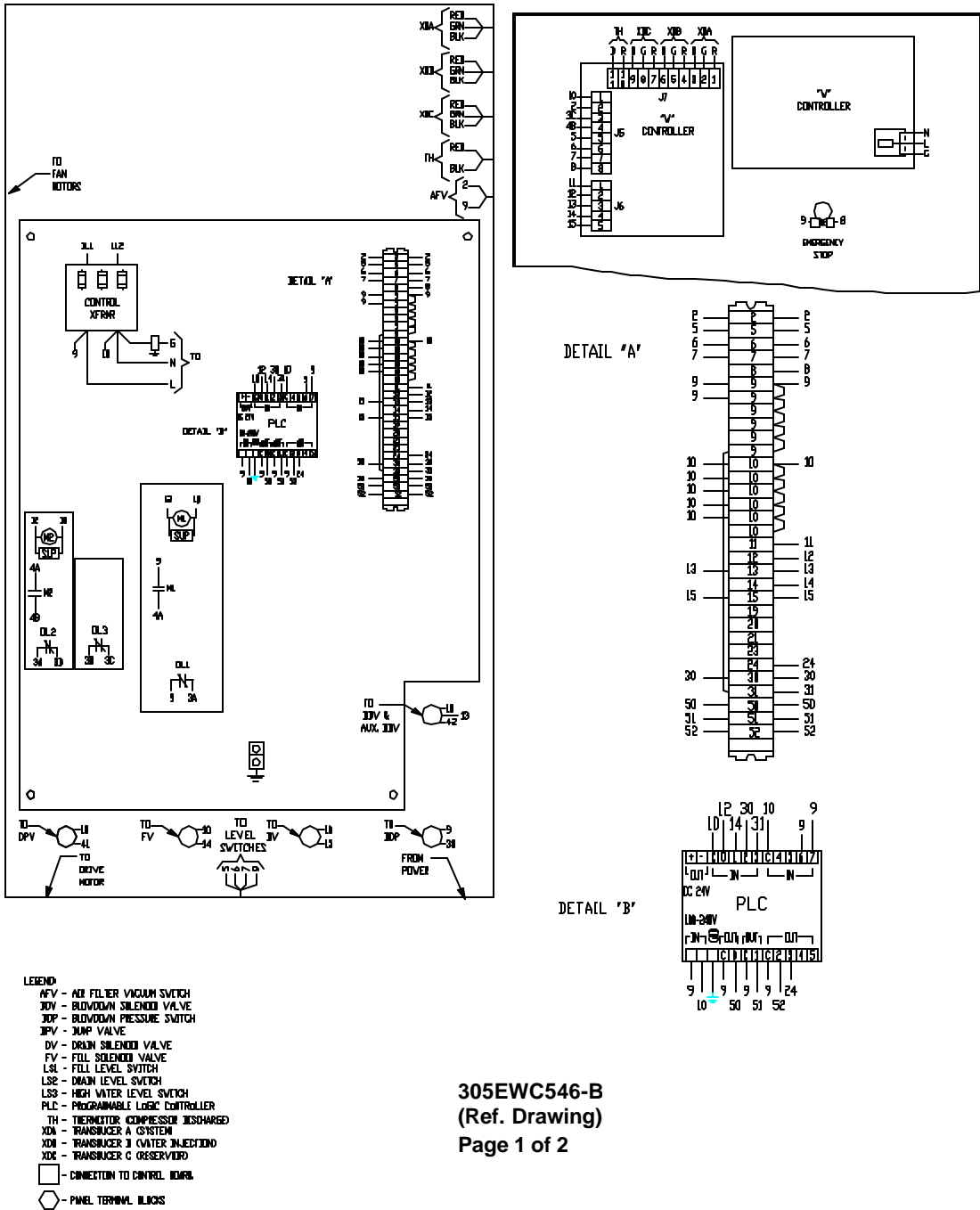
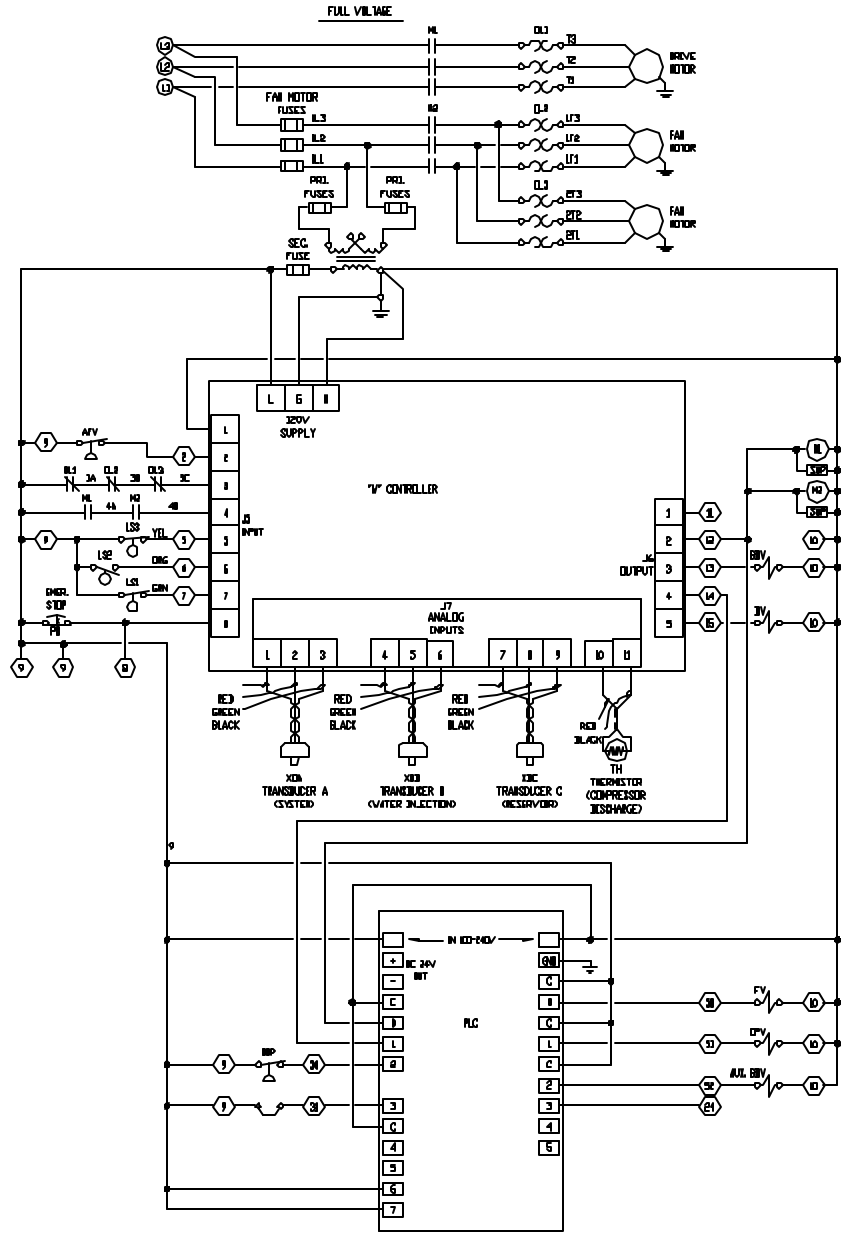

Figure 4-4 – WIRING DIAGRAM – FULL VOLTAGE

REVERSE CYCLES CYCLE TIME TABLE

TIME OFF	TIME ON	CONNECT WIRE TO PLC INPUT TERMINALS (GIVEN BY X)			
		4	5	6	7
3 MIN.	3 MYS				X
3 MIN.	2 MYS				X
3 MIN.	3 MYS			X	X
3 MIN.	5 MYS		X		
3 MIN.	7 MYS		X	X	
FULL OFF			X	X	
3 MIN.	3 MYS	X			X
3 MIN.	2 MYS	X		X	
3 MIN.	3 MYS	X	X		X
3 MIN.	5 MYS	X	X		X
3 MIN.	7 MYS	X	X	X	X
FULL OFF		X	X	X	
TEST 30 SEC	TEST 30 SEC	X	X	X	X



305EWC546-B
 (Ref. Drawing)
 Page 2 of 2

MAIN MOTOR	FV STARTER
FAN MOTOR	LOCAL AIR COOLED
CONTROLLER	"V"

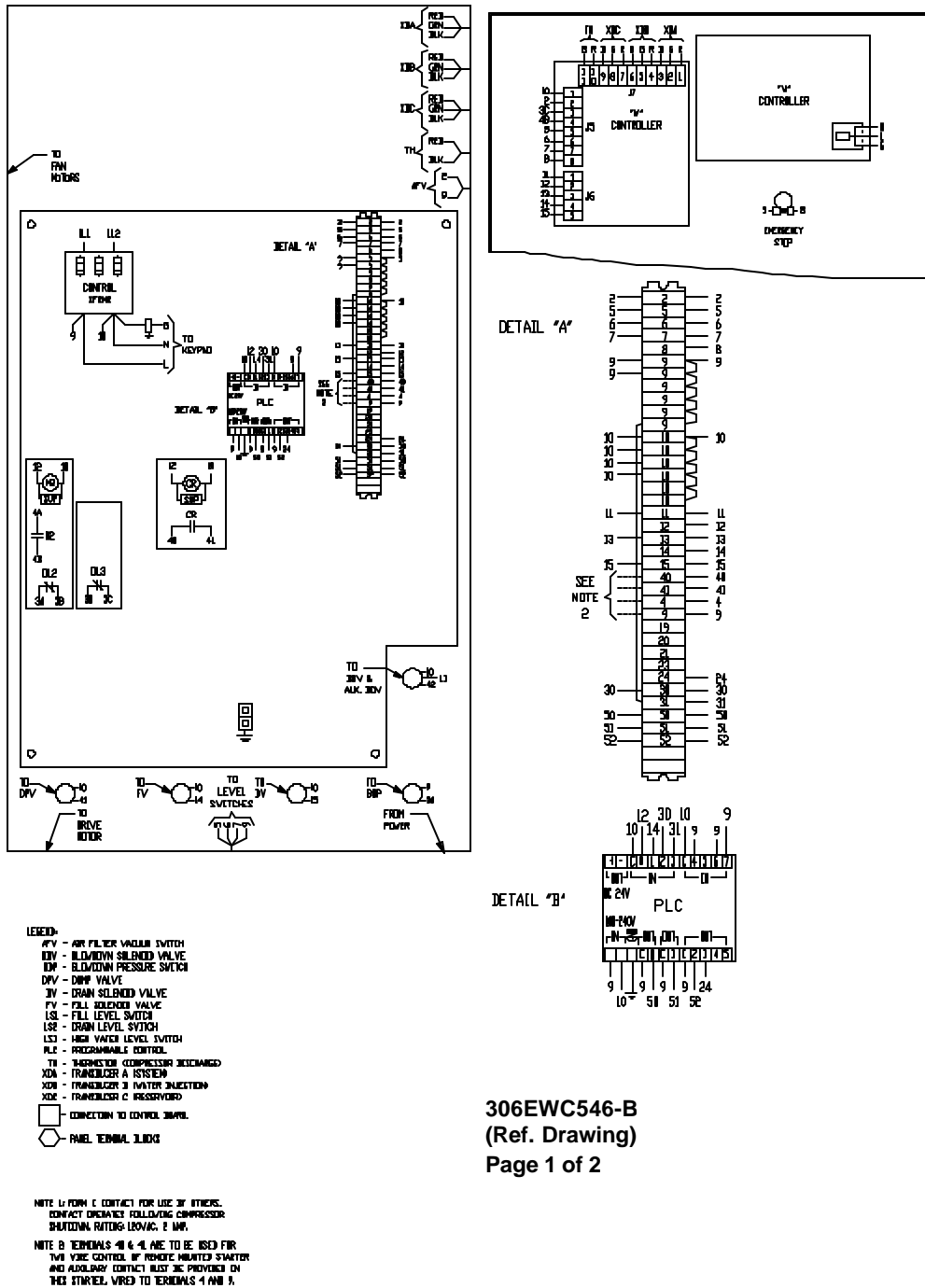

Figure 4-5 – WIRING DIAGRAM – FULL VOLTAGE LESS STARTER

SECTION 5 LUBRICATION

COMPRESSOR OIL SYSTEM - The airend oil reservoir is filled with oil and the inlet bearing lubrication fittings are greased at the factory before shipment. A tag on the reservoir fill cap indicates the type of oil in the reservoir as it left the factory.

RECOMMENDED LUBRICANT - Champion compressors are factory filled with RotorLub™ lubricants. These lubricants are formulated to the highest quality standards and are factory authorized, tested and approved for use in rotary screw compressors.

AEON lubricants are available through your authorized Champion compressor distributor.

OIL SPECIFICATIONS - The airend reservoir is factory filled with RotorLub 800 lubricant. A lubricant analysis program for a periodic check of lubricant quality and remaining life can maximize the change interval.

For grease specifications, refer to “Electric Motor Grease Specifications,” page 11.

Material Safety Data Sheets (MSDS) are available for all RotorLub lubricants from your authorized Champion distributor or by calling (815) 875-3321.



CAUTION

Use of improper lubricants will cause damage to equipment. Do not mix different types of lubricants or use inferior lubricants.



CAUTION

Improper equipment maintenance with use of synthetic lubricants will damage equipment. Oil change intervals must be adhered to for maximum compressor protection and efficiency. See “Maintenance Schedule”, page 51



WARNING

**High temperature operation can cause damage to equipment or personal injury.
Do not repeatedly restart the unit after high temperature stops the operation.
Find and correct the malfunction before resuming operation.**

LUBRICANT MAINTENANCE INTERVAL - The oil reservoir at the discharge end of the airend has a capacity of approximately 32 oz. (.8 liters). The oil bath type lubrication utilized does not require an oil filter or dedicated circulation hardware. As such, discharge end lubricant change intervals of 2000 hours are recommended as the only maintenance requirement in lieu of filter changes and circulation system maintenance.

NOTICE

IF OIL IS ANALYZED at the end of a maintenance interval (2000 hr. max.), and is found in good condition, it may be used for the next 2000 hour interval – GD provides free oil analysis services. OTHERWISE, IF OIL IS NOT ANALYZED at the end of any interval, it must be changed.

The drive end bearings of the airend should be lubricated with the prescribed grease every 2000 hours of operation until a small amount comes lightly out of the relief holes on the lower sides of the compressor inlet end or on the inlet end cover.

During initial start-up and after regreasing, a small amount of grease may be ejected from the relief holes. Wipe off any excess lubricant.

Severe operating conditions may require shorter regreasing intervals.

OIL LEVEL SIGHT GLASS -Figure 1-2, page 2) indicates the amount of oil in the airend oil reservoir. Read the oil level when the unit is off. In operation the oil level may fluctuate.

Add oil only when the oil level drops into the lower half of the glass. Drain oil only when the compressor is off.

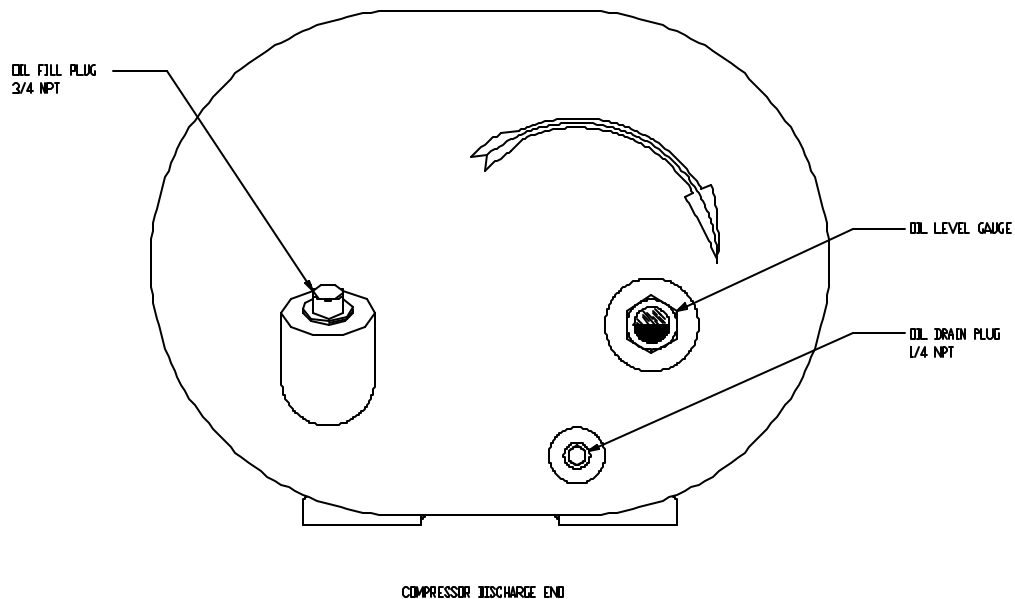

Figure 5-1 – OIL LEVEL SIGHT GLASS

SECTION 6 AIR FILTER

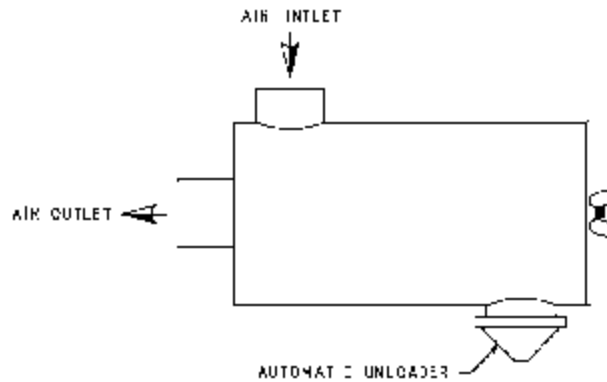

Figure 6-1 – HEAVY DUTY AIR FILTER (STANDARD)

HEAVY-DUTY AIR FILTER (Figure 6-1) furnished as standard equipment on units with an enclosure is a heavy-duty washable element dry type air filter. The air filter must receive proper maintenance if maximum service is to be obtained from the unit. Establishing adequate and timely filter service is MOST IMPORTANT. Improperly maintained air filter can cause a loss of compressor air delivery.

Filter Element - Service the air filter element when the “CHANGE AIR FILTER” message appears on the display accompanied by a yellow indicator in the status area of the keypad. Clean every 50 to 150 operating hours depending on dust conditions.

NOTICE

Use only genuine Champion air filter elements on Champion compressor units. Genuine parts are available through your authorized Champion distributor.

To service:

1. Remove the wing nut and pull out the filter element.
2. Visually inspect the element. If cleaning is not necessary, reinstall the filter element. If the element requires cleaning, go through Steps 3, 4 and 5.
3. Wash the element by soaking about 15 minutes in warm water with a mild non-sudsing detergent. Rinse the element thoroughly with clean water; a hose may be used if the water pressure does not exceed 40 psig (2.8 bar).

4. Inspect the element for ruptures or cracks in the pleated media; replace the element if any are found. Inspect the gasket on the bottom (outlet end) of the element; replace the entire element if the gasket is damaged. A spare element will keep down time to a minimum.
5. Allow the element to air dry COMPLETELY. Do not expose the element to heat over 150° F (66° C). Install the element in the filter body and fasten securely with the wing nut.



WARNING

Do not oil this element. Do not wash in inflammable cleaning fluids. Do not use solvents other than water. Improper cleaning may damage the element.

NOTICE

Never operate the unit without the element. Never use elements that are damaged, ruptured or wet. Never use gaskets that won't seal. Keep spare elements and gaskets on hand to reduce downtime. Store elements in a protected area free from damage, dirt and moisture. Handle all parts with care.

Filter Element Life - The element should be replaced after six (6) cleanings or if:

1. Visual inspection indicates a rupture, crack or pin hole in the pleated media. Inspection should be done by placing a bright light inside the element.
2. Pressure drop across a filter with a freshly cleaned element is below three (3) inches (76 mm) of water with the compressor running at full load - this would indicate a rupture or crack.

Inlet Tube - Inspect the inlet screen and tube for dirt accumulation each time the filter is serviced. Clean the tube when required by ramming a clean dry cloth through the tube. Wipe the inside of the filter body to remove any dirt falling from the inlet tube before reinstalling the element.

Causes of short element life include: severe dust conditions, infrequent servicing, improper cleaning, or contamination by oil or chemical fumes.

SECTION 7 BELT DRIVE

Proper drive belt tension and alignment are provided at the factory; however, good practice dictates checking the drive alignment and tension after shipment and before initial start-up.

Sheaves should align straight across the front with a straight edge. The best tension is just enough tension to keep belts from “squealing” on start-up.



CAUTION

Excessive belt tension can damage the equipment. Tension the belts as shown in Figure 7-1, page 43.

Belts can be changed when necessary by the following instructions: Disconnect, tag and lockout power to the starter, remove the belt guard, and loosen, but do not remove, the four motor foot nuts.

Next, use the adjusting screws in the motor base to loosen belt tension. Remove the belts, and replace with new belts. Check for correct belt tension and sheave alignment, tighten the motor foot bolts, and re-attach the wire guard.

CHECKING BELT TENSION - Using a spring scale, apply a perpendicular force to each belt at the midpoint of the span and measure the deflection. Correct deflection force and deflection are shown in Figure 7-1, page 43. To tighten belts, merely increase the center distance between the sheaves.

NOTICE

When a new set of belts is installed on a drive the initial deflection force should be 1/3 times greater than shown in Figure 7-1, page 43. Recheck tension frequently during the first 24 hours of operation.

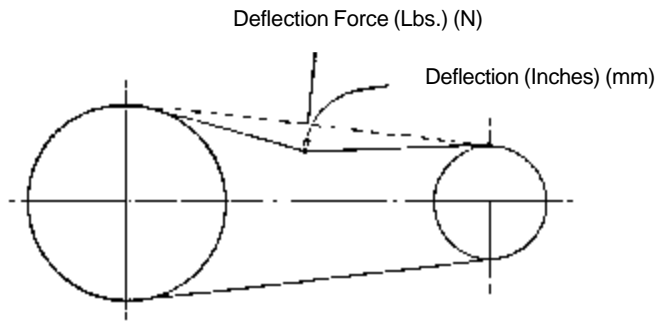

Motor H.P. (Kw)	No. of Belts	Deflection Force Pounds (Newtons) (per belt)	Deflection In Inches (mm)
20 (15 kW)	4	6 to 7 (1.3 to 1.5)	5/16 (8)
25 (19 kW)	4	6 to 8.5 (1.3 to 1.9)	5/16 (8)
30 (22 kW)	4	6 to 7 (1.3 to 1.5)	5/16 (8)

Figure 7-1 – BELT TENSION 3VX BELTS

SECTION 8

RO WATER FILTRATION SYSTEM

General Information:

The water mass utilized by the water-flooded screw compressor typically contains solids in dissolved and suspended forms. These solids, of organic and inorganic nature, are present in the local water supply or are deposited by the air stream pumped through the compressor, and usually contain corrosive and fouling agents. Under conditions which promote the precipitation of dissolved solids, the latter may deposit on adjacent surfaces and disrupt the transfer of heat in cooler cores, impede the motion of mechanical components (e.g., the inlet throttling valve, solenoid valves, etc.), or abrade the surface of shaft sealing elements. The concentration of solids residing in the close-loop water mass also increases with time. As the water evaporates by interacting with atmospheric air, and as the solubility of hardness-causing agents decreases with heat, solids precipitate and increase their amount in the water.

The RO (reverse osmosis) filtration system integrated into your compressor package overcomes the above-mentioned problems as follows:

- It provides a source of clean water, thus limiting the amount of fouling agents that may appear in the close-loop water mass.
- It provides regular, repeatable, and programmable exercising of the treatment filters, thus keeping their elements working at peak efficiency and prolonging their service life.
- It provides regular, repeatable, and programmable means to drain water from the close-loop system, thus flushing away any suspended solids.
- It operates the filtration system independent of compressor running state.

Principles of Operation:

The system layout is shown in the Figure 1-3, page 3, and the operation of its main components will be described as follows:

The sediment filter (hh) is the 1st stage of filtration provided. Its 5-micron element traps sediments such as silt, sand, grit, and sludge from the raw feed water.

The carbon filter (ii) follows the sediment filter. Its 10-micron element absorbs, among various compounds, chlorine, which is harmful to the RO membrane.

The back-pressure regulator (jj) controls the feed of water to the RO system. As the holding tank (nn) fills and water pressure builds up, the regulator stops water flow once the latter reaches 65% of the feed water pressure. Pressure gauge (xx) indicates the water pressure in the holding tank.

The RO filter (kk) is the last and finest filtration step of the system. Its semi-permeable membrane separates organic and inorganic impurities from the water, at the molecular level, when a pressure differential greater than the osmotic pressure of said impurities in the water is present. It fills the holding tank with 3.0 gal of filtered water in 2.2 hrs, when fed 14.4 gal of raw water at 90 psig, 70° F, and 150 TDS. The membrane requires a minimum raw feed water pressure of 50 psig to sustain the cleansing process. The quality and volume of treated water is proportional to both the pressure and the temperature of the raw feed water.

The capillary tube (mm) controls the flow of wash water used to flush away the contaminants captured by the RO membrane. The flushing process, active whenever the membrane is filtering water, requires 3.5 gpm of treated water for every 1 gpm of treated water delivered. The fast-flush valve (II) is provided to intensify the flushing process during periodic maintenance.

The 3.2 gal holding tank (nn) stores the filtered water output from the RO membrane for use in timed batch cycles. An internal flexible membrane, pressurized with 10 psig air (tank without water), helps evacuate the water from the holding tank.

The electronic timer module, included in the supplied programmable logic controller (PLC), and powered by 120 VAC, determines the frequency (off time) and duration (on time) of the RO system water dispensing cycles:

- The GD designed program is downloaded to the PLC via an RS485 port and is stored in a non-volatile EEPROM memory to end battery failure worries.
- The “off” cycles are adjustable in 1, 2, 3, 5 and 7 day intervals, and the “on” cycles are adjustable to a 3 or 5 minute intervals, but are typically set to 3 days “off”/3 minute. “on” cycles.
- A short test mode, 10 seconds “off”/5 seconds “on”, is provided to check the timer operation.
- Two additional cycles are provided to initially fill the reservoir with water in the field: 4 hour and 8 hour “on” cycles. These cycles allow the field user to fill the reservoir unattended – at the end of the “on” period, the cycle freezes in time until the mode switch is toggled off/on again.
- The setting of the cycles is accomplished via wire jumpers between PLC terminals 4, 5, 6, 7, and 9 – See Figure 8-1, page 47, for details.
- An external switch is provided to execute the program in memory (run mode) or to halt and/or allow the loading of programming (stop mode).
- The external switch, when toggled from “stop” to “run”, resets the time counter to 0 and initiates the “on” cycle first. This is particularly helpful when using one of the two fill cycles during initial package commissioning.
- At power-up, the timing sequence starts with the “off” cycle first. If the program execution is halted via the external “run/stop” mode switch, the cycle under operation is “frozen” in time until the switch is set back to “run”.
- During the “on” cycle, whenever the compressor is running, the “fill” relay and the water fill solenoid valve are energized and the water stored in the holding tank is admitted into the package water system via the compressor intake.
- During the “on” cycle, whenever the compressor is stopped, the dump solenoid valve is energized and the water stored in the holding tank is evacuated via the package drain tube-works.
- When the water level in the package receiver reaches a high level, the package high level float switch triggers the package ES controller to dump the excess water mass via the package drain valve.



CAUTION

Ensure that the PLC “run/stop” mode selection switch remains in the “run” position at all times – except during reprogramming. Failure to do so will halt the timed operation of the RO Filter System and will damage its membrane by fouling.

RO System Specifications :

Clean water flow capacity: 73 gpd (192ml/min) at 50 psig, 70° F, 150 TDS raw feed water.
94 gpd (247ml/min) at 90 psig, 70° F, 150 TDS raw feed water.

Effect of water temperature of on clean water production: 1.8% flow change for every degree of temperature change above (+) or below (-) 70° F rating.

Effect of water pressure on clean water production: 1.7% flow change for every psig of pressure change above (+) or below (-) a known (e.g., 90 psi or 50 psi) rating.

Raw water-to-clean water flow ration: System utilized 3.5 gal of raw water to discharge 1 gal of treated water.

Working pressure: 40 to 100 psig.

Working temperature: 40° F to 104° F.

Holding tank capacity: (5 gal model) holds 3.0 gal @ 10 psig membrane air pressure, 90 psig feed.
(5 gal model) holds 2.5 gal @ 10 psig membrane air pressure, 50 psig feed.
(7 gal model) holds 7.0 gal @ 10 psig membrane air pressure, 90 psig feed.
(7 gal model) holds 6.0 gal @ 10 psig membrane air pressure, 50 psig feed.

Holding tank evacuation time: 3.5 minutes when filled with 90 psig feed.
2.5 minutes when filled with 50 psig feed.

RO membrane design: spiral wound TFA

Sediment prefilter: 5-micron element, spun PPE w/o end caps, typical 4 psid loss clean at full flow.

Carbon prefilter: 10-micron charcoal element, PPE wrap/netting, w/end caps, typical 1 psid loss clean at full flow.

Rejection levels of various water-soluble compounds:

Calcium	96-98%
Copper	98-99%
Hardness	95-98%
Manganese	98-99%
Iron	95-98%
Lead	96-98%
Silica	85-90%
Sodium	87-98%
Sulfate	98-99%

Incoming raw water allowable contaminant concentrations:

Total Dissolved Solids (TDS):	1800 ppm
Iron	0.4 ppm
Hardness (non-carbonate)	293 ppm
Hydrogen Sulfide	.05 ppm
Manganese	.1 ppm
Silica	100 ppm
Turbidity	20 FTU
pH	6.5 to 8.5

Initial Set-Up and Operation:

The RO system is fully assembled and integrated into the compressor package.

As delivered, the new RO membrane contains a FDA approved preservative solution to prevent microbiological growth and freezing. This preservative will be flushed during the initial hours of operation.

Adjusting the cycle timer.

The frequency of fill-up cycles ultimately depends on the quality of the water within the main reservoir. Cycle times of 3 days “off” and 3 minutes “on” typically yield acceptable results – injection water TDS level is held below 60ppm and no suspended solids form. To conserve water, longer “off” time cycles may be used if the resulting injection water quality does not exceed 60 ppm and no suspended solids form.

Adjustment of the timer for 3 days “off” and 3 minutes “on” cycles is accomplished by interconnecting PLC terminal 4, 6, 7, and 9 with jumper wires. Refer to Fig 8-1 for PLC connections and cycle-time combinations available.

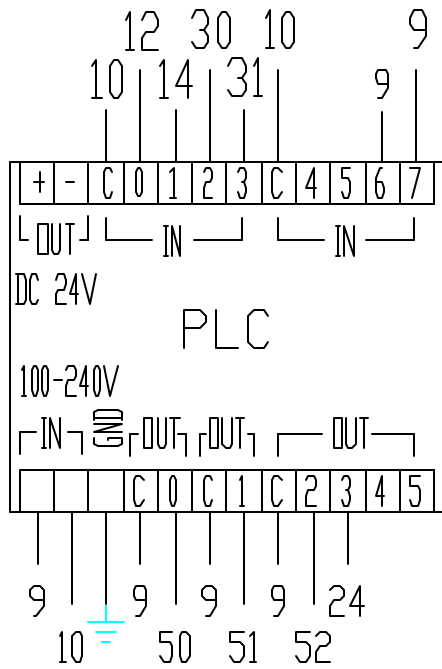

Reverse Osmosis Cycle Time Table

Time On	Time Off	Connect Wire # 9 to PLC Input Terminals (shown by "X")			
		4	5	6	7
3 Min.	1 Day				X
3 Min.	2 Days			X	
3 Min.	3 Days			X	X
3 Min.	5 Days		X		
3 Min.	7 Days		X		X
Fill 4 Hr.			X	X	
5 Min.	1 Day	X			X
5 Min.	2 Days	X		X	
5 Min.	3 Days	X		X	X
5 Min.	5 Days	X	X		
5 Min.	7 Days	X	X		X
Fill 8 Hr.		X	X	X	
Test 5 Sec.	Test 10 Sec.	X	X	X	X

Figure 8-1 – PLC CONNECTIONS AND CYCLE TIME COMBINATIONS

Maintenance:

Monitoring the water quality.

The performance of the RO system is directly related to the quality of the incoming raw water. It is critical that an on-site water-sampling schedule be originated to monitor the performance of the RO system.

By comparing specified rejection rates to those experimentally observed, the performance of the RO system is determined. For example, if the raw water feed and RO clean water total hardness are measured at 200 ppm and 5 ppm respectively, this is indicative that the system is performing adequately, as the normal rejection level for this compound is [200 ppm x 95% = 10 ppm].

Three (3) water test drains (gg, qq, and uu) have been provided to retrieve samples of the raw, clean, and injection water flows – make sure to run the test valve for a few seconds to get a fresh water sample. It is recommended that the following devices be available to check the water quality:

- Test strips. Hach (1-800-227-4224) supplies a vial with 50 strips which monitor 5 different water parameters (total chlorine, free chlorine, total hardness, total alkalinity, and pH) in a single paper strip (Cat. No. 27552-50). One other vial with 25 strips, monitors total iron (Cat. No. 27453-25), a very common contaminant (rust) in water pipes. A test only involves inserting the test strip in a water sample and comparing the resulting color changes to a chart printed on the vial. The results indicate gross water quality for trending purposes and serves as an early warning of upsets conditions that may require a formal laboratory analysis.
- TDS analyzer. Hach (1-800-227-4224) has available a pocket unit, Cat. No. 44400-00, which measures the total dissolved solids in water samples.



CAUTION

It is recommended that the quality of the water be checked weekly after the package is commissioned or after major repairs (e.g., aircend exchange) take place. If consistent results are obtained, the testing interval can be extended to longer testing periods, but these should not exceed 4 weeks.



CAUTION

The use of make-up water exceeding the quality limits outlined in the “RO Water Filter”, SECTION 8, may result in damage to critical compressor components by corrosion and/or scaling action of impurities in the water.

Monitoring the water flow

In addition to the water quality, it is important that the filtered water flow be checked monthly:

- Turn off the isolation valve (pp) on the water tank (nn).
- If the compressor is not running, just open the filtered water test point (qq), let it run for a few seconds to depressurize the line, and then time-collect a sample of the steady stream. Expect to collect between 192 to 247 ml/min of filtered water, depending on the raw feed water pressure.
- If the compressor is running, make sure that the fill solenoid valve (tt) does not open during the collection time, otherwise an erroneously low volume can result.

Filter cartridges.

The operational lives of the sediment and carbon filters elements vary with the quality of the raw feed water. As a general rule, they should be replaced yearly or whenever the reverse osmosis membrane is exchanged. Typical signs that these devices are plugging up are a decrease of clean water flow and/or an increase of chlorine in the clean water (carbon filter upset).

Replacing filter cartridges:

- Turn off the valve (ff) feeding raw water to the RO system.
- Open the raw and RO water test drains (gg, qq) to depressurize the water charge from the reservoir (nn) and lines.
- Unscrew the filter housing sumps by hand or with the provided spanner wrench – note that the o-ring may lift out of the housing and stick to the cap.
- Remove the used cartridges and discard. If signs of fouling are visible, rinse out the housings and fill 1/3 with water, then add 2-3 tablespoons of bleach, scrub clean with brush or sponge, and rinse thoroughly with water.
- Remove o-rings from the housings and wipe groove and o-ring clean. Lubricate o-rings with a coating of clean petroleum jelly. Place o-rings back into grooves and press with fingers to seat. If anyone o-ring appears damaged or crimped, replace immediately.
- Install the new cartridges into sumps making sure that it slips down over the sump standpipes.
- Turn the sump into the cap and hand-tighten – do not over-tighten.
- Close the raw water test point.
- Open the raw water shutoff valve. After a minute or so, a trickle of water should be coming from the open RO water test drain, indicating the system is again producing water. Close now the RO water test drain.
- The water reservoir, at a minimum raw water pressure of 50 psig, will fill up in about 2 hours.

RO membrane

The operational life of the RO membrane also varies with the quality of the raw feed water. As a general rule, it should be replaced every 1-2 years. Typical signs that the device is plugging up are a decrease of clean water flow and a decrease of rejection of levels of compounds found in the site water. If rejection of any compound falls below a 70% level consistently, the membrane should be replaced and so should the sedimentation and carbon cartridges.

Whenever the rejection levels start decreasing below their minimum acceptable value, a fast-flush valve (ll) is provided to temporarily increase the internal cleansing of the membrane and hopefully restore membrane performance. If the fast-flushing procedure does not restore the rejection performance, than the membrane must be replaced.

Replacing the RO membrane:

- Turn off the valve (ff) feeding raw water to the RO system.
- Open the raw and RO water test drains (gg, qq) to depressurize the water charge from the reservoir (nn) and lines.
- Disconnect the processed water line from the RO housing end cap via the quick disconnect fitting.
- Unscrew the end cap from the housing – reasonable force may have to be used.
- Remove the used membrane and discard.
- Lubricate two end o-rings with a coating of clean petroleum jelly.
- Install the new membrane into housing with two o-rings end first.
- Lubricate o-rings on membrane housing with a coating of clean petroleum jelly.
- Thread the cap back on hand-tighten firmly.
- Close the raw water test point.
- Open the raw water shutoff valve. After a minute or so, a trickle of water should be coming from the open RO water test drain, indicating the system is again producing water. Close now the RO water test drain.
- The water reservoir, at a minimum raw water pressure of 50 psig, will fill up in about 2 hours.

SECTION 9

MAINTENANCE SCHEDULE

SERVICE CHECK LIST

Air Filter - Operating conditions determine frequency of service. When the air pressure differential across the filter reaches 25" H₂O, the "CHANGE AIR FILTER" message appears on the display accompanied by a yellow indicator in the status area of the keypad signaling that the air filter requires servicing or changing. See "Air Filter," Section 6, page 40.

Water Filter - Operating conditions and water quality determine the frequency of service. When the water pressure differential across the filter reaches 30 psi, the "CHANGE H₂O FILTER" message appears on the display accompanied by a yellow indicator in the status area of the keypad, signaling that the water filter requires changing.

To change the filter:

1. Be sure the unit is completely off and that no air pressure is in the system.
2. Disconnect, tag and lockout the power supply to the starter.
3. Drain the water from the filter housing by either turning the petcock or removing the plug on the bottom of the filter assembly.
4. Remove the nut at the top of the filter assembly, while holding the filter housing to keep it from dropping. When the nut is removed, change the filter and reassemble.
5. Repeat Steps 3 and 4 on the makeup water filter.
6. Reconnect the power supply to the starter, start the machine and check for leaks.

RO Water Filtration System - Operating conditions and water quality determine the frequency of service. Refer to Section 8 for detailed maintenance instructions.

Motor Lubrication - Refer to Section 2, page 11.

Every 8 Hours Operation

1. Observe if the unit loads and unloads properly.
2. Check discharge pressure and temperature.
3. Check Panel Status indicators and message line for advisories.
4. Check that there is condensate flow in the plastic connected between the aftercooler liquids separator drain and the inlet valve.
5. Check that there is no accumulation of condensate in the bowl of the control air filter.
6. Check setting of buffer air pressure regulator – normal pressure is 5 psig to 7 psig.
7. Check setting of buffer water pressure regulator – normal pressure is 2 psig to 3 psig.

Every 125 Hours Operation

1. Check for dirt accumulation on oil/aftercooler core faces and the cooling fan. If cleaning is required, clean the exterior fin surfaces of the cores by blowing compressed air carrying a nonflammable safety solvent in a direction opposite that of the cooling fan air flow. This cleaning operation will keep the exterior cooling surfaces clean and ensure effective heat dissipation.
2. Check the airend reservoir oil level - add oil if required. Loss of oil will be because of seal failure or leaks in the system and should be fixed immediately.
3. Check the level of condensate in the control air filter bowl. Use the manual pet cock to evacuate any accumulation and check the operation of the automatic float valve. Cleanse the automatic float valve as needed.
4. Check the quality of the raw (incoming), RO (treated) and injection (reservoir) water. Refer to Section 8, for recommendations to check the water quality.

Every 500 Hours Operation

1. Check the delivery of filtered water from the reverse osmosis system.

Refer to the RO Filtration System, SECTION 8, "Monitoring the Water Flow", for the recommended procure.

Every 2000 Hours Operation

1. Change the airend lubricant. UNDER ADVERSE CONDITIONS, CHANGE MORE FREQUENTLY (refer to "Oil Change Interval" in Section 5). Flush reservoir if required. DO NOT MIX LUBRICANTS.
2. Grease the fittings on the inlet end of the airend (refer to "Lubrication Maintenance Interval", page 39).
3. Visually inspect makeup water feeder cartridge. Replace when no material is observed in the cartridge.

Every Year

1. Check the relief valve for proper operation. See Section 4, page 30.

MAINTENANCE SCHEDULE (See Detail Notes)

Maintenance Action	As indicated by AUTO SENTRY W	Every 8 Hours	Every 125 Hours	Every 500 Hours	Every 2000 *	Every Year
Change Air Filter	•					
Change Water Filter	•					
Check for Proper Load/Unload		•				
Check Discharge Pressure/Temp		•				
Check Dirt Accumulation on Cooler			•			
Check Reservoir Oil Level			•			
Change Compressor Lubricant (RotorLub 800)	•				•	•
Check Relief Valve						•
Check the Check Valve Seals						•
Add Grease to Inlet End Bearings					•	
Check Water Quality **			•			
Check Water Flow (RO Filter Discharge)				•		
Inspect Makeup Water Treatment Cartridge					•	
Check Condensate Flow at Aftercooler Separator Drain		•				
Check Condensate Level in Control Air Filter Bowl		•				
Check Setting of Buffer Air Pressure Regulator		•				
Check Setting of Buffer Water Pressure Regulator		•				

* IF OIL IS ANALYZED at the end of a maintenance interval (2000 hr. max.), and is found in good condition, it may be used for the next 2000 hour interval – Champion provides free oil analysis services. OTHERWISE, IF OIL IS NOT ANALYZED at the end of any interval, it must be changed.

** Depends on water quality – longer periods may be used when the quality of water meets or exceeds our standards consistently.

SECTION 10 TROUBLESHOOTING

SYMPTOM	POSSIBLE CAUSE	REMEDY
Compressor fails to start	<ol style="list-style-type: none"> 1. Wrong lead connections. 2. Blown fuses in control box. 3. Motor starter overload heaters tripped. 4. Pressure in reservoir. 5. Read error message on control panel. 6. Remote Contact is open. 	<ol style="list-style-type: none"> 1. Change leads. 2. Replace fuse. 3. Reset and investigate cause of overload 4. Inspect blowdown valve. 5. Take appropriate action. See Section 4. 6. Replace switch or jumper (terminals 6 & 9).
Compressor starts but stops after a short time	<ol style="list-style-type: none"> 1. High discharge temperature. 2. High discharge temperature switch malfunction. 3. Blown fuse in starter/control box. 4. Motor starter overload heaters trip. 	<ol style="list-style-type: none"> 1. See "High discharge air temperature", this Section. 2. Replace switch. 3. Replace fuse (investigate if fuses continue to blow). 4. Reset and investigate cause of overload.
Compressor does not unload (or load)	<ol style="list-style-type: none"> 1. Improperly adjusted control. 2. Air leak in control lines. 3. Restricted control line. 4. Blowdown valve malfunction. 	<ol style="list-style-type: none"> 1. Refer to Section 4 and adjust control. 2. Determine source of leak and correct. 3. Clean control lines. 4. Repair, clean or replace valve.
Compressor shuts down or falters while unloading	<ol style="list-style-type: none"> 1. Purge air pressure reaching airend is excessive. 	<ol style="list-style-type: none"> 1. Adjust auxiliary blowdown pressure switch to the proper level. See Section 4 for adjustment details. Replace if defective.
Compressor cycles from load to unload excessively	<ol style="list-style-type: none"> 1. Insufficient receiver capacity. 2. Restriction in control tubing. 	<ol style="list-style-type: none"> 1. Increase receiver size. 2. Inspect and clean control tubing.

SYMPTOM	POSSIBLE CAUSE	REMEDY
Compressor is low on delivery and pressure	<ol style="list-style-type: none"> 1. Restricted air filter. 2. Sticking inlet valve. 3. Unload pressure adjusted too low. 4. Discharge check valve stuck closed. 5. Subtractive valve is active. 	<ol style="list-style-type: none"> 1. Clean or replace filter. 2. Inspect and clean inlet valve. 3. Adjust the unload pressure. See Section 4. 4. Disassemble and clean valve. 5. Adjust subtractive valve to start operating at 1 psi above the desired full load operating pressure. Clean or replace if output is not linear - 2.3 psi output per 1 psi input.
High discharge air temperature	<ol style="list-style-type: none"> 1. Dirty or clogged cooler face. 2. Insufficient cooling air flow 3. Clogged water injection filter or cooler (interior). 4. Reservoir water level low 	<ol style="list-style-type: none"> 1. Clean cooler. 2. Provide unrestricted supply of cooling air. 3. Replace filter or clean cooler. 4. See "Reservoir water level low" details.
Reservoir water level low	<ol style="list-style-type: none"> 1. Drain valve leaking 2. RO producing none to low water. 3. Condensate return strainer and/or orifice plugged. 	<ol style="list-style-type: none"> 1. Inspect and clean or replace. 2. See RO Troubleshooting details. 3. Inspect and clean.
Abnormal water volume found in package discharge air	<ol style="list-style-type: none"> 1. Condensate return strainer and/or orifice plugged. 	<ol style="list-style-type: none"> 1. Inspect and clean.

NOTICE

Champion factory remanufactured replacement compressor airend units are available from your authorized distributor, on an exchange basis, for all rotary screw compressor units.

SECTION 11

TROUBLESHOOTING AUTO SENTRY W CONTROLLER W

DISPLAY MODES

A green power on light is located in the lower right corner of the keypad. It lights whenever the controls are energized. A steady light indicates that automatic restarting is not enabled, the compressor must be restarted manually following a power failure. A blinking green light indicates that the control will automatically resume its selected mode following an interruption in power.

The normal display indicates the package service pressure, the airend discharge temperature, the total running hours, and one of the following operating modes. The green run light will be on for any operating mode, whether the compressor is running or not.

READY	The compressor has been stopped by pressing the [STOP/RESET] key
CON	The compressor is operating in the Constant Run mode
LDM	The compressor is operating in the Low Demand mode
AUTO	The compressor is operating in the Automatic mode
SEQ n	The compressor is operating in the Sequence mode

The following alternate displays may be called by pressing the [?] or a cursor [<] or [>] key. The [?] key always displays DIF PRES on the first press; the cursor keys will redisplay the last alternate display. Any will scroll through the list with additional presses.

DIF PRES	The pressure drop across the water filter
RES PRES	The pressure in the water reservoir
INJ PRES	The pressure between the filter and injectors
SYS PRES	The pressure at the service connection
DIS TMP	The temperature at the airend discharge
TOT HRS	The total hours of compressor running
LOAD HRS	The hours of compressor delivery
BD TMR	The time remaining before a blowdown will be allowed
AUTO TMR	The time remaining of unloaded motor operation

ADVISORY TROUBLESHOOTING GUIDE

All advisories are indicated on the keypad by a yellow indicator in the Status area, and one of the following messages alternating with the normal lower line display. Perform service or maintenance as indicated, then clear the advisory as instructed in Section 4.

Message	Action Needed
CHNG AIR FILTER	Excessive vacuum has been detected after the air filter, indicating it has become full. Change the air filter to ensure maximum air delivery.
CHNG H ₂ O FILTER	The differential pressure across the water filter has risen to over 30 psid. Change the filter to ensure an adequate flow of coolant.
RELUBE	The unit has been operated for the programmed number of hours since the last lubricant change or addition. Change or add lubricant as indicated in the lubrication instructions to ensure lubricant quality.
HIGH DISCH TEMP	The temperature was greater than 180° F (82° C) at the airend discharge. Ensure that the compressor receives adequate cooling air or water, and that the coolers are not plugged.
LOW AMB TEMP	The temperature was less than 40° F (4° C) at the airend discharge. Ensure that the compressor is located in a room kept above freezing.

SHUTDOWN TROUBLESHOOTING GUIDE

All shutdowns are indicated on the keypad by the word "SHUTDOWN" on the top line of the display, and one of the following messages on the lower line of the display. The red indicator in the Status area will be steadily lit while the conditions exist, and will flash after the condition has been corrected. Perform service as indicated. Press the [STOP/RESET] key to clear the shutdown.

Message	Action Needed
BAD FLOAT SWITCH	120 volts is present at both terminal 6 and 7 of the terminal strip. This indicates a likely wiring error to the float switch; check and correct. It may also indicate a short within the switch itself.
CHECK CN7	All inputs at connector 7 of the controller are off. The most common cause for this is that the connector plug has been pulled out. Plug the connector back in firmly.
CHECK CN5	120 volts has been removed from ALL inputs to connector 5 of the controller. The most common cause for this is that the connector plug has been pulled out. Plug the connector back in firmly.
CHNG H ₂ O FILTER	The differential pressure across the water filter has risen to over 40 psid. Change the filter to ensure an adequate flow of coolant.
EMERGENCY STOP	The Emergency Stop button has been pressed. Pull it back out to its normal position. If the button has not been pressed, check that the contact block is firmly mounted in the right or left (not center) position of the operator. Check for loose connections which would remove 120 volts from connector 5-8 of the controller.

Message	Action Needed
EXTERNAL DEVICE	120 volts has been removed from J1-4 of the expansion board. This is normally jumpered directly to terminal 9, but the jumper may be removed to add a field installed shutdown switch. Reset the external switch.
HIGH DIS TEMP R	This indicates that the controller has detected a rapid temperature rise in the airend discharge. This normally would indicate a loss of coolant injection into the airend. Completely check all water piping, the filter, and flow controls for blockage or freezing. This may also be caused by a loose connection at connector 7 of the controller. Monitor the temperature carefully during restarts after servicing.
HIGH DISCH TEMP	This indicates that the controller has detected temperature in excess of the programmed high temperature limit at the airend discharge. The most common cause for this is inadequate package cooling. Ensure proper air flow for air-cooled units, or adequate cooling water for water cooled units. Monitor the temperature carefully during restarts after servicing.
HIGH INJ PRESS	Pressure in excess of the programmed high pressure limit has been detected. This shutdown will occur if a loss of pneumatic controls occurs. Check the inlet valve, all control piping, solenoid valves, and all other control devices to find the cause for the inlet valve not closing. Other possible causes are loose connections to the transducer, electrical noise and transients, or improper setting of the high pressure limit.
HIGH RESVR PRESS	Pressure in excess of the programmed high pressure limit has been detected. This shutdown will occur if a loss of pneumatic controls occurs. Check the inlet valve, all control piping, solenoid valves, and all other control devices to find the cause for the inlet valve not closing. Other possible causes are loose connections to the transducer, electrical noise and transients, or improper setting of the high pressure limit.
HIGH SYSTEM PRESS	Pressure in excess of the programmed high pressure limit has been detected. The most likely cause is other, higher pressure compressors on the same air system; separate these from this compressor unit. Other possible causes are loose connections to the transducer, electrical noise and transients, or improper setting of the high pressure limit.
HIGH VIBRATION	120 volts has been removed from J1-4 of the expansion board. This is normally jumpered directly to terminal 9, but the jumper may be removed to add a field installed shutdown switch. Reset the external switch.
HIGH WATER LEVEL	120 volts has been removed from terminal 5 of the terminal strip. This normally indicates that a high water level in the reservoir has opened switch LS3 of the float switch assembly. Check that the drain is clear and that the drain solenoid valve is functioning properly. This may also indicate a loose connection along wire 5.
LOW DISCH TEMP	The temperature, as measured at the airend discharge, has fallen below freezing. Repair room heating to prevent further damage to the unit.

Message	Action Needed
LV RELAY	120 volts has been removed from J1-4 of the expansion board. This is normally jumpered directly to terminal 9, but the jumper may be removed to add a field installed shutdown switch. Reset the external switch.
MOTOR CONTACT	The controller has attempted to turn off the compressor, but is still receiving a return signal from the starters' auxiliary contacts. Check that the starter operates freely and that the contact blocks are properly installed on the starter.
MOTOR OVERLOAD	One of the motor overload relays within the electrical control box has tripped, indicating high motor shaft load, low voltage, or excessive imbalance in the incoming power. Disconnect and lock out power, open the box, and press the reset buttons one at a time - the tripped one will click when reset. Measure motor amps, and take corrective actions to get all currents within the motor nameplate rating. If overloads had not tripped, check for the cause that 120 volts was removed from connector 5-3 of the controller.
MOTOR STARTER	The controller has attempted to start the compressor, but did not receive a return signal from the starter's auxiliary contact. If the starter does not pick up when attempting to start, check that connector 6 of the controller is plugged in firmly, and check the starter coil. If the starter does pick up, but this message appears, check that the auxiliary contact block is properly installed on the starter and wired to connector 1, terminal 4.
OPEN THERMISTOR	The controller has detected an open connection to the airend discharge thermistor. This normally indicates a loose or broken connection at the controller connector 7; check and correct the connection. This could also be indicating a broken wire or thermistor probe.
OPEN XDUCER	Signal voltage has fallen too low at transducer: (A) Final discharge, (B) Water Injection, or (C) Reservoir. This usually indicates a loose connection of the red wire to the transducer or a defective transducer. Check connections, or replace transducer if necessary.
PHASE RELAY	120 volts has been removed from J1-4 of the expansion board. This is normally jumpered directly to terminal 9, but the jumper may be removed to add a field installed shutdown switch. Reset the external switch.
POWER FAILURE	The power to the compressor unit has been turned off and back on. Press [STOP/RESET] and select an operating mode.
SHORTED THERMSTR	The controller has detected a shorted connection to the airend discharge thermistor. This normally indicates a faulty connection (e.g. wire strands touching) at the controller connector 7; check and correct the connection. This could also be indicating a damaged wire or thermistor probe.
SHORTED XDUCER	Signal voltage has exceeded approximately 4.6 volts at transducer: (A) Final discharge, (B) Water Injection, or (C) Reservoir. This may indicate a loose connection of the black wire to the transducer or a defective transducer. Check connections, or replace transducer if necessary.

Message	Action Needed
WATER PRESS	120 volts has been removed from J1-4 of the expansion board. This is normally jumpered directly to terminal 9, but the jumper may be removed to add a field installed shutdown switch. Reset the external switch.
ZERO XDUCER	Signal voltage has fallen too low at transducer: (A) Final discharge, (B) Water Injection, or (C) Reservoir. This error is usually the result of the transducers being improperly zeroed. Disconnect the air lines to the transducers and follow the procedure indicated in the adjustment instructions.

CONTROLS TROUBLESHOOTING GUIDE

The following are recommended service actions. Observe all instructions noted elsewhere in this manual. All electrical service is to be performed only by a qualified electrician.

Message	Action Needed
No display, compressor stopped	Check incoming power to the compressor unit. Ensure that the disconnect is on and that fuses have not blown (or circuit breaker tripped). If power is being properly supplied to the control box, check the fuses located at the fan starter, the control transformer fuses, and the fuse located on the AUTO SENTRY W keypad chassis.
Compressor will not start	To operate, the controller must be placed into an operating mode (e.g. AUTO); press the [STOP/RESET] key to put the control into the READY state, then start by pressing the [START] key. In AUTOMATIC and SEQUENCE modes, compressors will not start until the pressure drops below the load pressures.
Display indicates "NOT BLOWN DOWN"	The controller prevents attempts to start the main motor if the reservoir pressure is over 5 psig. Pressure continues to be relieved from the reservoir while this message is on, and the compressor will start automatically after the pressure has dropped. If this message remains with NO pressure in the reservoir, follow the transducer zeroing procedure found in the controls adjustment section.
Display indicates "REMOTE STOP"	The controller is provided with an input for user-furnished remote controls. This display indicates that 120 volt is removed from terminal 23 of the terminal strip. Check all connections of the expansion board, or the customer-provided controls, if applicable
Display indicates "SHUTDOWN"	If the display indicates "SHUTDOWN", refer to the shutdown troubleshooting section for assistance. In addition to the messages shown, there are several internal and system diagnostics performed by the controller. Consult the factory for additional assistance.

Message	Action Needed
Compressor runs, but does not load	In the CONSTANT RUN and LOW DEMAND modes, the compressor will not load until the pressure drops below load pressure. Refer to the operating instructions for further information. If pressure is below the load pressure, check that the inlet valve operates freely. Check that the unloader valve is wired and operating properly.
Compressor runs, unloads at low pressure Compressor does not unload	If the inlet valve closes at low pressure, check the wiring to the blowdown valve and the piping and check valves in its discharge line. The W controller operates the inlet valve to maintain pressure near the unload pressure, matching delivery to demand. If the pressure continues to rise above unload pressure, check that the inlet valve operates freely, and that control air is supplied to the unloader solenoid valve. If normal unload control does not close the valve, it will be closed during a blowdown as pressure approaches the high pressure limit.
Compressor cycles rapidly between load and unload	The external air receiver should be sized appropriately to prevent rapid cycles. The rapid response time in the CONSTANT RUN mode will operate with small receivers, but any plant air system will operate more efficiently with adequately sized storage. Refer to the operating instructions for further information.
Display is illegible.	The LCD contrast is adjustable from all black to all green. To adjust, find the small adjustment screw located on the larger circuit board behind the keypad. Using a small screwdriver, adjust for the most pleasing display.
Erratic pressures in SEQUENCE only	The sequencing system transmits low-level signal between units to communicate pressures. Units must be properly grounded to a good ground system. The communications cable should use only appropriate quality cable, and the cable should be run in its own conduit.
Compressor cycles rapidly in SEQUENCE mode only	In the sequence mode, the operating system requires all compressors be piped directly to receiver, such that all transducers sense the same pressure. Check valves or restrictions between compressors and the storage will cause system instability. Run units in AUTOMATIC mode until the system is corrected.
Pressure display error.	Accuracy of the pressure display and controls requires that the controller and transducers be calibrated together. This MUST be done with no pressure at the transducer, or errors will occur. This is easiest to check with all pressure removed. All pressure displays should indicate 0 psi (0 bar) +1 psi. If the display indicates greater pressures, recalibrate the system as instructed in the configuration adjustments. Note: reservoir pressure may drop below zero psig when the compressor is stopped, but will return slowly to zero as the vacuum is relieved.

SECTION 12

TROUBLESHOOTING THE RO FILTRATION SYSTEM

Problem: None or low water production

Reasons:

Solutions:

Raw water feed (gg) turned off.	Open raw feed water valve.
Pre-filters (ll, hh) fouled or plugged.	Replace cartridges.
Raw water feed pressure below 50psig.	Improve pressure condition.
Back pressure regulator (jj) plugged.	Cleanse or replace.
Membrane fouled or plugged.	Fast-flush or replace.
Storage tank (nn) under pressurized.	Adjust membrane air pressure (15-20 psi).
Storage tank membrane ruptured.	Replace storage tank.
Isolation valve (pp) turned off.	Open isolation valve.
Fill valve (tt) leaking or stuck open.	Cleanse or replace

Problem: High TDS product water

Reasons:

Solutions:

Membrane fouled.	Fast-flush or replace.
TDS increased in raw water feed.	Check that TDS < 1800 ppm.
Membrane fouled.	Fast-flush or replace.
Prefilter housings not flushed.	Repeat housing cleansing and flushing.

Problem: Cloudy water

Reasons:

Solutions:

Dissolved oxygen in feed water is concentrated In product water.	Oxygen dissolves from water over time
--	---------------------------------------

INDEX

Air Filter, Section 6	40	Discharge Service Line.....	9
Air Flow In The Compressor System.....	1	Electrical Wiring.....	10
Auto Sentry W Controller		Enclosure	7
Alarm Relay	29	Foundation.....	7
Automatic Sequence Change	27	General.....	5
Auxiliary Shutdown.....	29	Grounding.....	10
Configuration Adjustments	23	Inlet Line	8
Connection Of Expansion Board And External Control		Lifting Unit.....	5
Circuits	28	Location.....	5
Control Display	16	Moisture Separator/Orifice	8
Installation.....	25	Motor Lubrication.....	11
Main Adjustments Menu	21	Oil Reservoir Drain.....	7
Maintenance Adjustments	22	Unit Water Drain	9
Operation Adjustments	21	Lubrication, Section 5	38
Other Control Devices	30	Compressor Oil System.....	38
Other Control Features.....	24	Electric Motor Grease Recommendations	11
Other Features	27	Electric Motor Regreasing Interval.....	11
Programming And Setup	21	Maintenance Interval	39
Remote On/Off.....	29	Motor	11
Sequence Adjustments	22	Oil Level Sight Glass	39
Sequencing Compressor	24	Oil Specifications	38
Unit Setup Adjustments	23	Recommended	38
Auto Sentry W Operation.....	15	Maintenance Schedule, Section 9	51
Automatic Mode.....	16	Prestart-Up Instructions	12
Constant Run Mode.....	15	Air Filter.....	12
Low Demand Mode.....	16	Compressor Oil.....	12
Sequence Mode	16	Electrical.....	12
Belt Drive, Section 7	42	Enclosure	13
Control Devices, Other	30	Grounding.....	13
Air Filter Vacuum Switch.....	32	Initial Water Fill/Adjusting Ro Timer.....	14
Air Pressure Regulator.....	31	Operating Mode	13
Aux. Blowdown Vavle.....	30	Piping.....	12
Aux. Pressure Switch.....	30	Rotation	13
Blowdown Valve.....	30	System Pressure.....	13
Check Valve.....	31	RO Water Filtration, Section 8	44
Control Transformer	33	General Information.....	44
Discharge Termistor	32	Initial Set-Up And Operation	47
Emergency Stop/Push Button	33	Maintenance.....	48
Fan Starter	33	Principles Of Operation	44
Injection Pressure Transducer.....	32	RO Membrane.....	50
Inlet Valve.....	31	RO System Specifications	46
Main Starter.....	33	Safety Precautions	4
PLC.....	32	Service Advisories	18
Pressure Gauge.....	31	Service Check List.....	51
Relief Valve.....	30	Shutdowns	
Reservoir Pressure Transducer.....	32	Emergency Stop.....	19
Shuttle Valve.....	31	External Device.....	19
Subtractive Valve.....	31	High Pressure	19
System Pressure Transducer	31	High Temperature.....	18
Terminal Strip	33	High Water Level.....	19
Water Level Switches.....	32	Motor Protective Devices	18
Water Pressure Regulator.....	31	Other	19
Water Pressure Relief Valve.....	31	Power Failure	19
Water Solenoid Valves	32	Water Filter Differential Pressure	19
Controls & Instrumentation, Section 4.....	15	Starting & Operating Procedures, Section 3.....	12
Coolers & Water Systems, Section 2.....	5	Starting The Unit.....	14
Compression Injection Water System Check.....	9	Stopping The Unit	14
Compressor Water Specifications	7	Troubleshooting	
Water System.....	1	Auto Sentry W Controller, Section 11.....	56
General Information, Section 1	1	Advisory Troubleshooting Guide.....	57
Installation, Section 2.....	5	Controls Troubleshooting Guide	60
Air/Water Reservoir With Integral Moisture Separator.....	9	Display Modes	56
Air-Cooled Units	5	Shutdown Troubleshooting Guide.....	57
Auxiliary Air Receiver	8	General, Section 10.....	54
Compressor Injection Water System Check.....	9	RO Filtration System, Section 12.....	62
Compressor Water Specification.....	7		



**WARRANTY
ROTARY SCREW COMPRESSORS AND VACUUM PACKAGES
OIL INJECTED – OIL FREE**

GENERAL PROVISIONS AND LIMITATIONS

Champion (the "Company") warrants to each original retail purchaser ("Purchaser") of its new products from the Company or its authorized distributor that such products are, at the time of delivery to the Purchaser, made with good material and workmanship. No warranty is made with respect to:

1. Any product which has been repaired or altered in such a way, in the Company's judgment, as to affect the product adversely.
2. Any product which has, in the Company's judgment been subject to negligence, accident, improper storage, or improper installation or application.
3. Any product which has not been operated or maintained in accordance with the recommendations of the Company.
4. Components or accessories manufactured, warranted and serviced by others.
5. Any reconditioned or prior owned product.

Claims for items described in (4) above should be submitted directly to the manufacturer.

WARRANTY PERIOD

The Company's obligation under this warranty is limited to repairing or, at its option, replacing, during normal business hours at an authorized service facility of the Company, and part which in its judgment proved not to be as warranted within the applicable Warranty Period as follows.

COMPRESSOR AIRENDS

Compressor airends, consisting of all parts within and including the compressor cylinder and gear housing, are warranted for 24 months from date of initial use or 27 months from date of shipment to the purchaser, whichever occurs first.

Any disassembly or partial disassembly of the airend, or failure to return the "unopened" airend per Company instructions, will be cause for denial of warranty.

MAJOR COMPRESSOR PACKAGE COMPONENTS

The drive motor, air or water cooled coolers and the AutoSentry Controller are warranted for 24 months from date of initial use or 27 months from date of shipment to the first purchaser, whichever occurs first.

OTHER COMPONENTS

All other components are warranted for 12 months from date of initial use or 15 months from date of shipment to first purchaser, whichever occurs first.

LABOR TRANSPORTATION AND INSPECTION

The Company will provide labor, by Company representative or authorized service personnel, for repair or replacement of any product or part thereof which in the Company's judgment is proved not to be as warranted. Labor shall be limited to the amount specified in the Company's labor rate schedule.

Labor costs in excess of the Company rate schedule amounts or labor provided by unauthorized service personnel is not provided for by this warranty.

All costs of transportation of product, labor or parts claimed not to be as warranted and, of repaired or replacement parts to or from such service facilities shall be borne by the Purchaser. The Company may require the return of any part claimed not to be as warranted to one of its facilities as designated by Company, transportation prepaid by Purchaser, to establish a claim under this warranty.

Replacement parts provided under the terms of the warranty are warranted for the remainder of the Warranty Period of the product upon which installed to the same extent as if such parts were original components.

DISCLAIMER

THE FOREGOING WARRANTY IS EXCLUSIVE AND IT IS EXPRESSLY AGREED THAT, EXCEPT AS TO TITLE, THE COMPANY MAKES NO OTHER WARRANTIES, EXPRESSED, IMPLIED OR STATUTORY, INCLUDING ANY IMPLIED WARRANTY OF MERCHANTABILITY.

THE REMEDY PROVIDED UNDER THIS WARRANTY SHALL BE THE SOLE, EXCLUSIVE AND ONLY REMEDY AVAILABLE TO PURCHASER AND IN NO CASE SHALL THE COMPANY BE SUBJECT TO ANY OTHER OBLIGATIONS OR LIABILITIES. UNDER NO CIRCUMSTANCES SHALL THE COMPANY BE LIABLE FOR SPECIAL, INDIRECT, INCIDENTAL OR CONSEQUENTIAL DAMAGES, EXPENSES, LOSSES OR DELAYS HOWSOEVER CAUSED.

No statement, representation, agreement, or understanding, oral or written, made by any agent, distributor, representative, or employee of the Company which is not contained in this Warranty will be binding upon the Company unless made in writing and executed by an officer of the Company.

This warranty shall not be effective as to any claim which is not presented within 30 days after the date upon which the product is claimed not to have been as warranted. Any action for breach of this warranty must be commenced within one year after the date upon which the cause of action occurred.

Any adjustment made pursuant to this warranty shall not be construed as an admission by the Company that any product was not as warranted.



©2000 Gardner Denver, Inc.
Litho in U.S.A.

www.championpneumatic.com

Champion
1301 North Euclid Avenue
Princeton, Illinois 63156 USA
Phone: (815) 875-3321
Fax: 815-872-0421



E-mail: champion@championpneumatic.com

Plants in Princeton IL, and Manteca, CA

Due to Champion's continuing product development program, specification and materials are subject to change without notice.