CHAMPION[®]

13-11-507
1st Edition
February, 1999

ROTORCHAMP[®]
OIL-FREE ROTARY SCREW
COMPRESSORS

MODEL

RCOF20 - 20 HP
RCOF25 - 25 HP
RCOF30 - 30 HP

PARTS LIST



INSTRUCTIONS FOR ORDERING REPAIR PARTS

When ordering parts, specify Compressor MODEL, Method of Cooling, HORSE-POWER and SERIAL NUMBER (see nameplate on unit). The Serial Number is also stamped on top of the cylinder flange to the right of the inlet housing.

All orders for Parts should be placed with the nearest authorized distributor.

Where NOT specified, quantity of parts required per compressor or unit is one (1); where more than one is required per unit, quantity is indicated in parenthesis. SPECIFY EXACTLY THE NUMBER OF PARTS REQUIRED.

DO NOT ORDER BY SETS OR GROUPS.

To determine the Right Hand and Left Hand side of a compressor, stand at the motor end and look toward the compressor. Right Hand and Left Hand are indicated in parenthesis following the part name, i.e. (RH) & (LH), when appropriate.

TABLE OF CONTENTS

Page No.

Instructions For Ordering Repair Parts	1
Maintain Compressor Reliability and Performance with Genuine Championr Compressor Parts and Support Services	3
Remanufactured Air Ends	3
Basic Assembly Group	4, 5
Bare Compressor	6, 7, 8
Air End Replacements	6
Inlet Valve Group	9
Compressed Air Piping	10, 11
Water Piping Group	12, 13
Control Fitting Group	14, 15, 16, 17
Drain Piping	18, 19
Controller Assembly - Full Voltage Starters - Illustration	20
Controller Assembly - Full Voltage Starters - 20 H.P. Units	21
Controller Assembly - Full Voltage Starters - 25 H.P. Units	22
Controller Assembly - Full Voltage Starters - 30 H.P. Units	23
Controller Assembly - Less Main Starter	24, 25
Common Fabricated Parts	26
Enclosure Group	27
Enclosure Hardware	28
Identification and Instruction Group	29
Drive Group	30, 31, 32
Motor Group - Main Drive Motors - Full Voltage	33
Motors (Fan Motor - 2 Required) (60 HZ-TEFC)	33
Overload Relay Heater Conversion Listing	34
Repair Kits	35

For Operating and Service Instructions see:

SERVICE MANUAL 13-11-605

**MAINTAIN COMPRESSOR RELIABILITY AND PERFORMANCE WITH
GENUINE CHAMPION^R COMPRESSOR
PARTS AND SUPPORT SERVICES**

Champion^R Compressor genuine parts, manufactured to design tolerances, are developed for optimum dependability -- specifically for Champion^R compressor systems. Design and material innovations are the result of years of experience with hundreds of different compressor applications. Reliability in materials and quality assurance are incorporated in our genuine replacement parts.

Your authorized Champion^R Compressor distributor offers all the backup you'll need. A worldwide network of authorized distributors provides the finest product support in the air compressor industry. Your local authorized distributor maintains a large inventory of genuine parts.

Your authorized distributor can support your Champion air compressor with these services:

1. Trained parts specialists to assist you in selecting the correct replacement parts.

2. Factory warranted new and remanufactured rotary screw air ends. Most popular model remanufactured air ends are maintained in stock at Champion for purchase on an exchange basis with liberal core credit available for the replacement unit.
3. A full line of factory tested RotorLub compressor lubricants specifically formulated for use in Champion compressors.
4. Repair and maintenance kits designed with the necessary parts to simplify servicing your compressor.

Authorized distributor service technicians are factory-trained and skilled in compressor maintenance and repair. They are ready to respond and assist you by providing fast, expert maintenance and repair services.

For the location of your local authorized Champion Air Compressor distributor refer to the yellow pages of your phone directory or contact:

Factory:
Champion
1301 N. Euclid Ave.
Princeton, IL 61356
Phone: (815) 875-3321
Fax: (815) 872-0421

REMANUFACTURED AIR ENDS

Whenever an air end requires replacement or repair, Champion offers an industry unique, factory remanufactured air end exchange program. From its modern Remanufacturing Center in Indianapolis, IN, Champion is committed to supplying you with the highest quality, factory remanufactured air ends that are guaranteed to save you time, aggravation and money.

Immediately Available

Repair downtime costs you money, which is why there are over 200 remanufactured units in inventory at all times, ready for immediate delivery.

Skilled Craftsmen

Our Remanufacturing assembly technicians average over 20 years experience with air compression products.

Precision Remanufacturing

All potentially usable parts are thoroughly cleaned, inspected and analyzed. Only those parts that can be brought back to original factory specifications are remanufactured. Every remanufactured air end

receives a new overhaul kit: bearings, gears, seals, sleeves and gaskets.

Extensive Testing

Champion performs testing that repair houses just don't do. Magnaflux and ultrasonic inspection spot cracked or stressed castings, monochromatic light analysis exposes oil leaks, and coordinate measurement machine inspects to +/- .0001", insuring that all remanufactured air ends meet factory performance specifications.

Warranty

Champion backs up every remanufactured air end with a new warranty . . . 18 months from purchase, 12 months from service.

Champion remanufactured air ends deliver *quality without question . . . year in and year out.*

Call Champion for information on the air end exchange program and the name of your authorized distributor.

Phone Number: (815) 875-3321 or
FAX: (815) 872-0421

BASIC ASSEMBLY GROUP

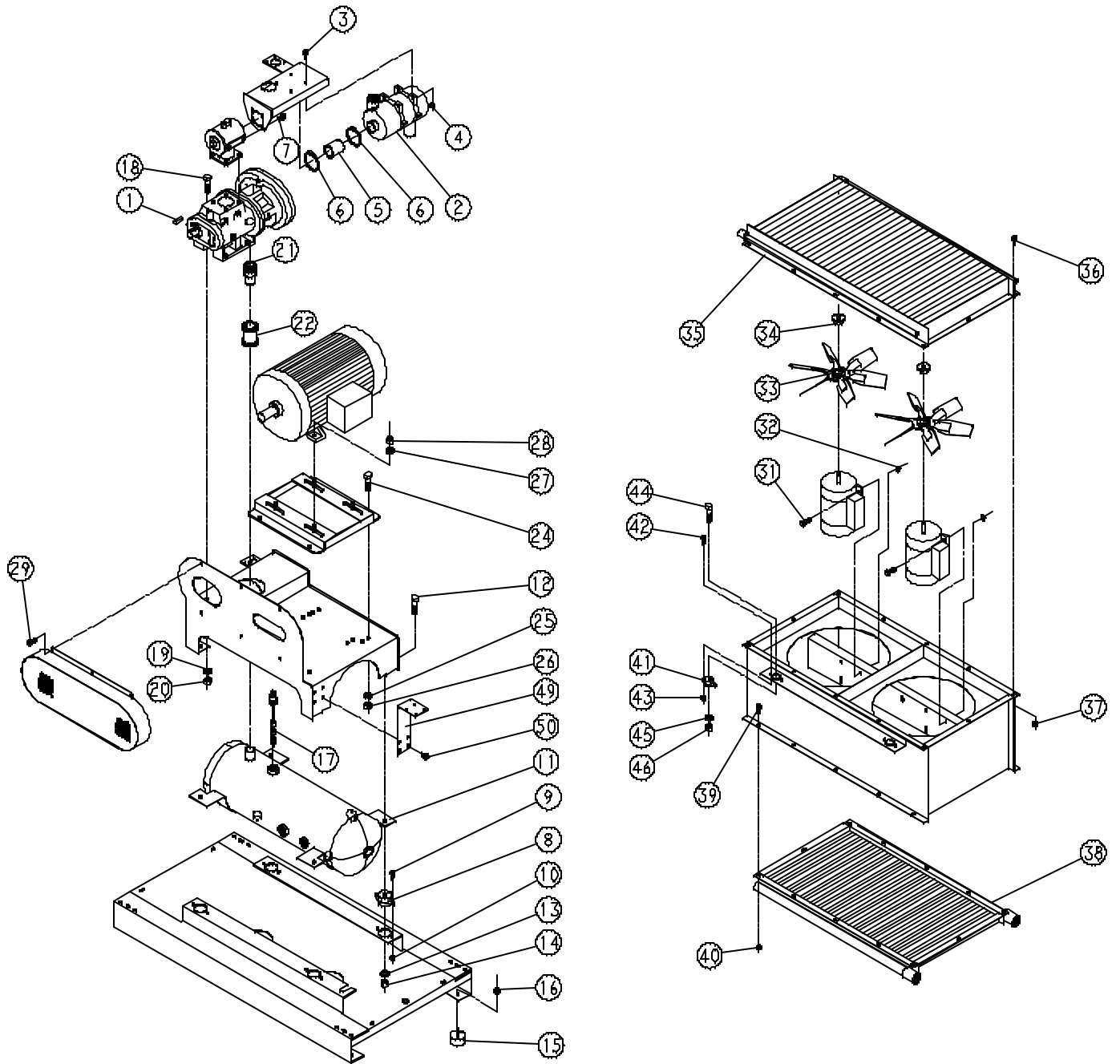

301EWC810-C
(Ref. Drawing)

BASIC ASSEMBLY GROUP

Ref. No.	Name of Part	Qty.	Part No.
1	KEY	1	8501217
2	FILTER-AIR	1	5L220
3	SCREW-FLANGED HD	4	75LM50
4	NUT-FLANGED	4	50AW4
5	HOSE-COOLANT	1	29A60
6	CLAMP	2	29B32
7	SCREW	4	75LM51
8	ISOLATOR-VIBRATION	4	49C46
9	SCREW	4	75LM51
10	NUT-FLANGED	4	50AW5
11	SEPARATOR-MOIST	1	300EWC1443
12	SCREW	4	655EF140
13	LOCKWASHER	4	95B7
14	NUT	4	50B7
15	VIB ISOLATOR	4	49C102
16	NUT	4	50AW35
17	SWITCH	1	300EWC375
18	SCREW	4	655EE060
19	WASHER	4	95B5
20	NUT	4	50B5
21	NIPPLE	1	64EB879
22	COUPLING-FLEXIBLE	1	64EB810
24	SCREW	4	655EE050
25	WASHER	4	95B5
26	NUT	4	50B5
27	WASHER	4	95B5
28	NUT	4	50B5
29	SCREW	6	75LM51
31	SCREW-FLANGED HD	8	75LM97
32	NUT-FLANGED	8	50AW4
33	FAN	2	300EWC701
34	BUSHING-SHEAVE	2	22G36
35	COOLER-WATER	1	300EWC257
36	SCREW	12	75LM51
37	NUT-FLANGED	12	50AW5
38	AFTERCOOLER	1	300EWC292
39	SCREW	12	75LM51
40	NUT-FLANGED	12	50AW5
41	VIB ISOLATOR	4	49C58
42	SCREW-FLANGED HD	8	75K54
43	NUT-FLANGED	8	50AW4
44	SCREW	4	75A102
45	LOCKWASHER	4	95B2
46	NUT	4	50B2
49	BRACKET-HOUSING	1	300EWC142
50	SCREW-FLANGED HD	4	75K48

BARE COMPRESSOR

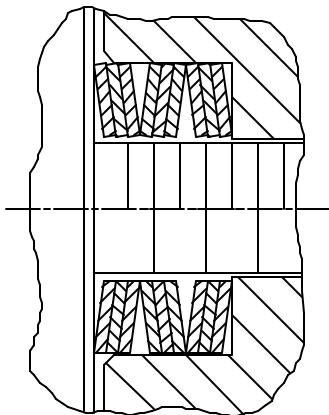
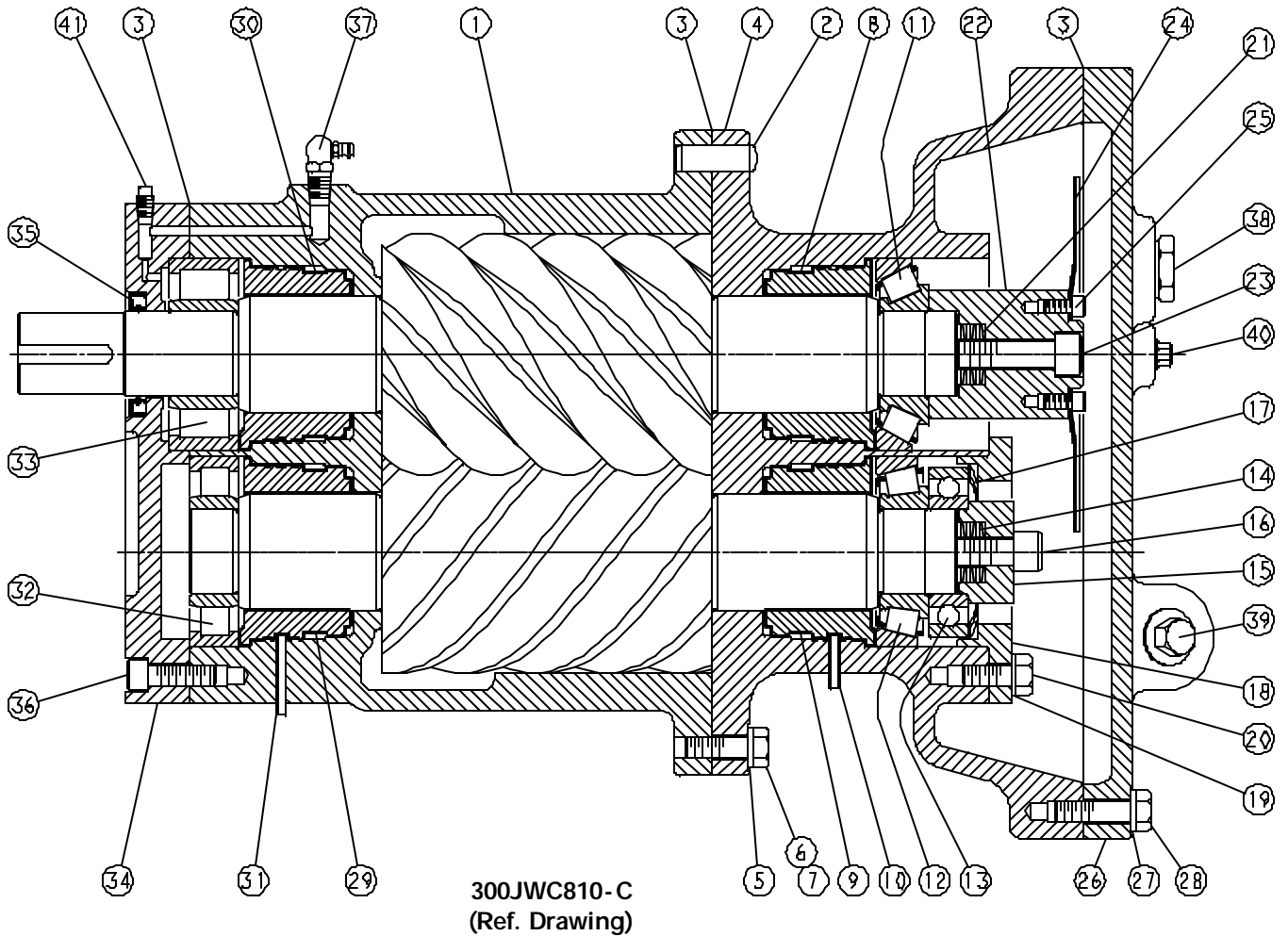

ITEMS NO. 14 & 21
TO BE INSTALLED
AS SHOWN ABOVE

AIREND REPLACEMENTS

HP	NEW AIREND	REMANUFACTURED AIREND
20	JWCABA	JWCABAX
25	JWCABA	JWCABAX
30	JWCABA	JWCABAX

NOTICE

New and Remanufactured Air Ends are available from the
Champion Master Distribution Center.

BARE COMPRESSOR

Ref. No.	Name of Part	Qty.
1	CYLINDER-AIR	1
2	PIN-DOWEL	2
3	GASKET-ELIMINATOR	1
4	HOUSING-BEARING	1
5	LOCKWASHER	10
6	SCREW	9
7	SCREW	1
8	SEAL	1
9	SEAL	1
10	PIN- SPRING ROLL	2
11	BEARING	1
12	BEARING	1
13	BEARING	1
14	SPRING	9
15	PLATE-BEARING RETAINER	1
16	SCREW-SOC HD CAP	1
17	SPRING	1
18	RETAINER	1
19	LOCKWASHER	4
20	SCREW	4
21	SPRING	9
22	PLATE-BEARING RETAINER	1
23	SCREW	1
24	SLINGER	1
25	SCREW SOC HD CAP	2
26	COVER	1
27	LOCKWASHER	10
28	SCREW	10
29	SEAL	1
30	SEAL	1
31	PIN- SPRING ROLL	2
32	BEARING	1
33	BEARING	1
34	HOUSING- SEAL	1
35	SEAL-OIL	1
36	SCREW-SOC HD CAP	9
37	FITTING-PIPE	2
38	GAUGE	1
39	PLUG	1
40	PLUG	5
41	PLUG	6
*	PLUG	6
*	PLUG	8

* Not shown.

Order by Part Number and Description. Reference Numbers are for your convenience only.

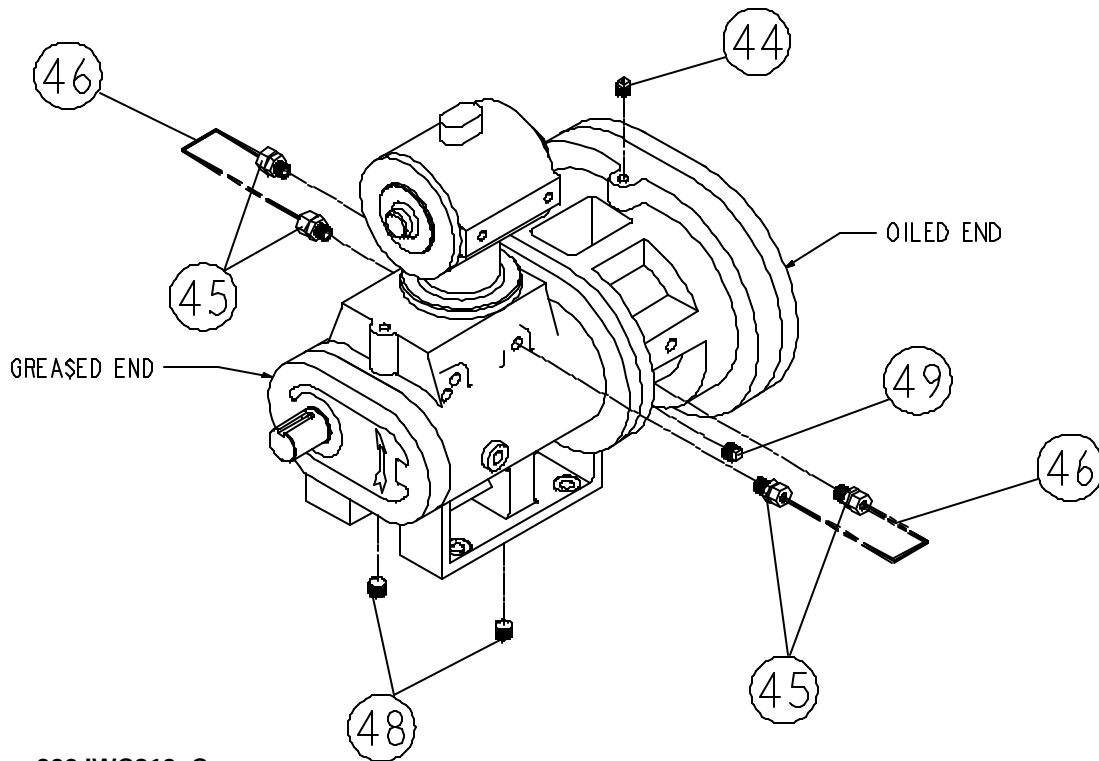

300JWC810-C
(Ref. Drawing)

NOTE: ITEMS 45 AND 46 ARE USED FOR SEAL SCAVENGE AND RETURN.
ITEM 47 IS NOT SHOWN. ITEM 49 IS FOR PLUGGING OF UNUSED
DISCHARGE TEMPERATURE PORT.

BARE COMPRESSOR

Ref. No.	Name of Part	Qty.	Part No.
44	ORIFICE	1	204WBO814
45	CONNECTOR-TUBE	4	86E9
46	TUBE	2	85G5
48	PLUG	2	00901923 0002
49	PLUG-SQHD PIPE	1	64AJ2
*	LUBRICANT	1	28H188

* Not shown.

Order by Part Number and Description. Reference Numbers are for your convenience only.

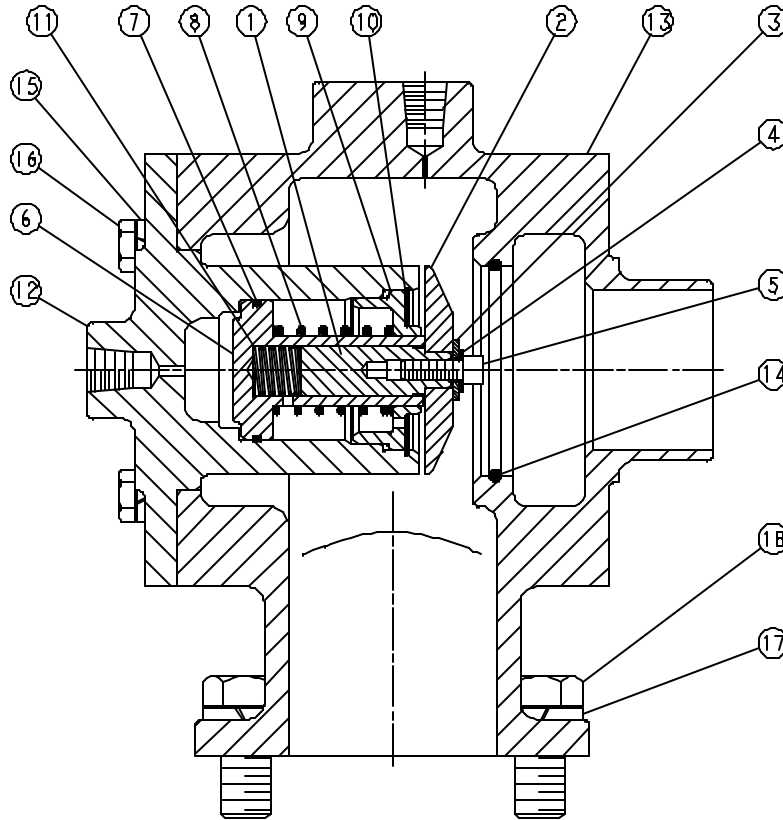

300JWE810
(Ref. Drawing)

INLET VALVE GROUP

Ref. No.	Name of Part	Qty.	Part No.
1	GUIDE- VALVE	1	201SSE483
2	VALVE-INLET	1	300JWE044
3	WASHER	1	95A1C
4	LOCKWASHER	1	95H16
5	SCREW	1	655EC03N
6	PISTON-INLET VALVE	1	300JWE043
7	O-RING	1	5100498
8	SPRING	1	78H22
9	RETAINER	1	300JWE205
10	RING-RETAINING	1	74D92
11	SPRING	1	78W59
12	CYLINDER-INLET VALVE	1	300JWE420
13	HOUSING-INLET	1	300JWE041
14	O-RING	1	25AM15
15	LOCKWASHER	4	95B3
16	SCREW	4	655ED040
17	LOCKWASHER	4	95B3
18	SCREW	4	655ED040
*	GASKET-ELIMINATOR	1	25BC256

* Not shown.

COMPRESSED AIR PIPING

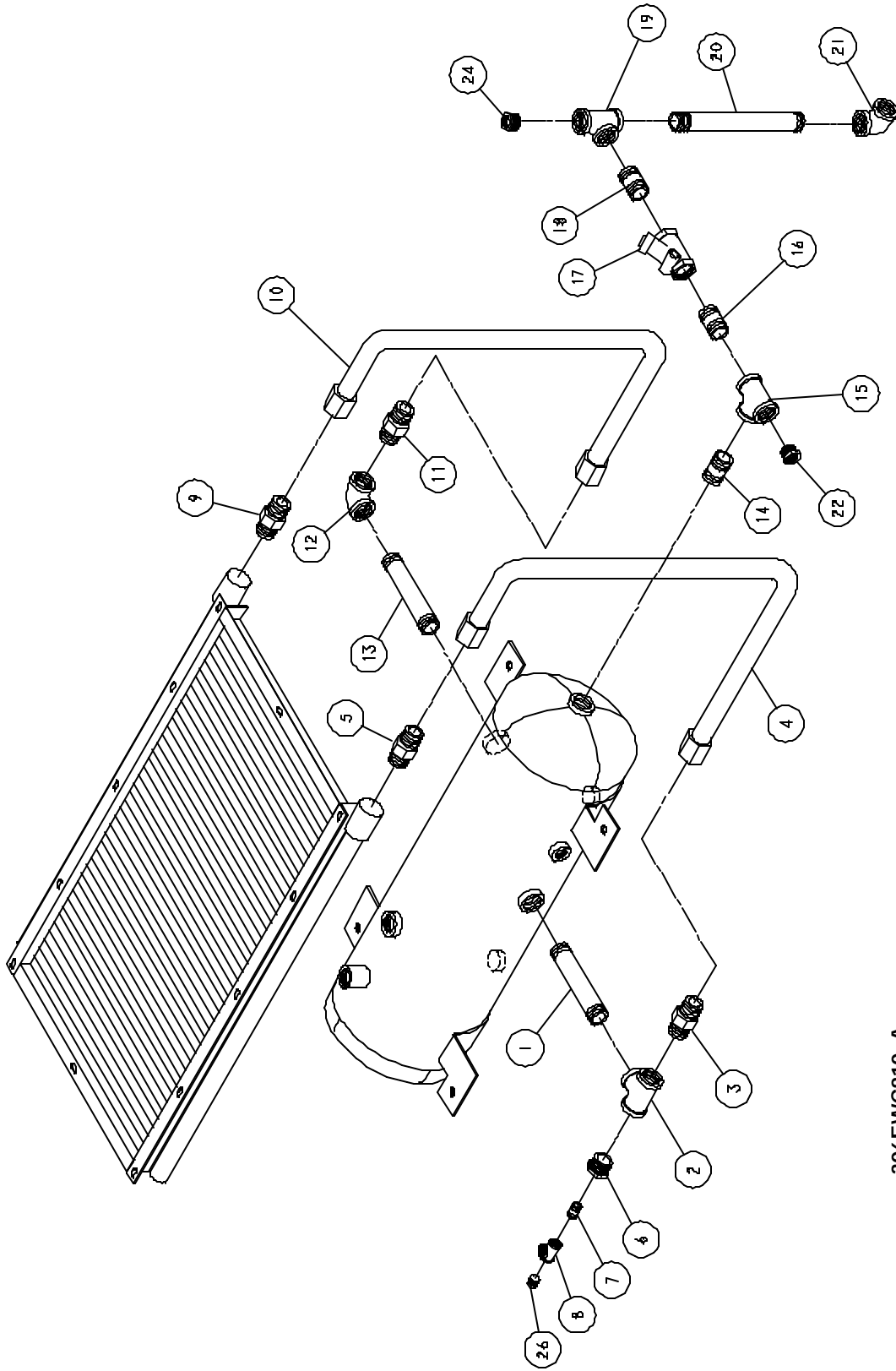

FINAL DISCHARGE

306EWC810-A
(Ref. Drawing)

Order by Part Number and Description. Reference Numbers are for your convenience only.

COMPRESSED AIR PIPING

Ref. No.	Name of Part	Qty.	Part No.
1	NIPPLE	1	64EB812
2	TEE	1	64EB814
3	CONNECTOR-TUBE	1	86H143
4	TUBE-WITH FITTING	1	300EWC863
5	CONNECTOR-TUBE	1	86H143
6	BUSHING-PIPE (BRASS)	1	64EB811
7	NIPPLE	1	63Z15
8	TEE-PIPE	1	64G15
9	CONNECTOR-TUBE	1	86H143
10	TUBE-WITH FITTING	1	301EWC863
11	CONNECTOR-TUBE	1	86H143
12	ELBOW-PIPE	1	64EB254
13	NIPPLE	1	64EB812
14	NIPPLE	1	64EB813
15	TEE	1	64EB814
16	NIPPLE	1	64EB813
17	VALVE-CHECK	1	90J131
18	NIPPLE	1	64EB813
19	TEE	1	64EB814
20	NIPPLE	1	64EB812
21	ELBOW-PIPE	1	64EB254
22	BUSHING-PIPE	1	64EB337
24	BUSHING-PIPE	1	64EB337
26	PLUG	1	64AJ2

WATER PIPING GROUP

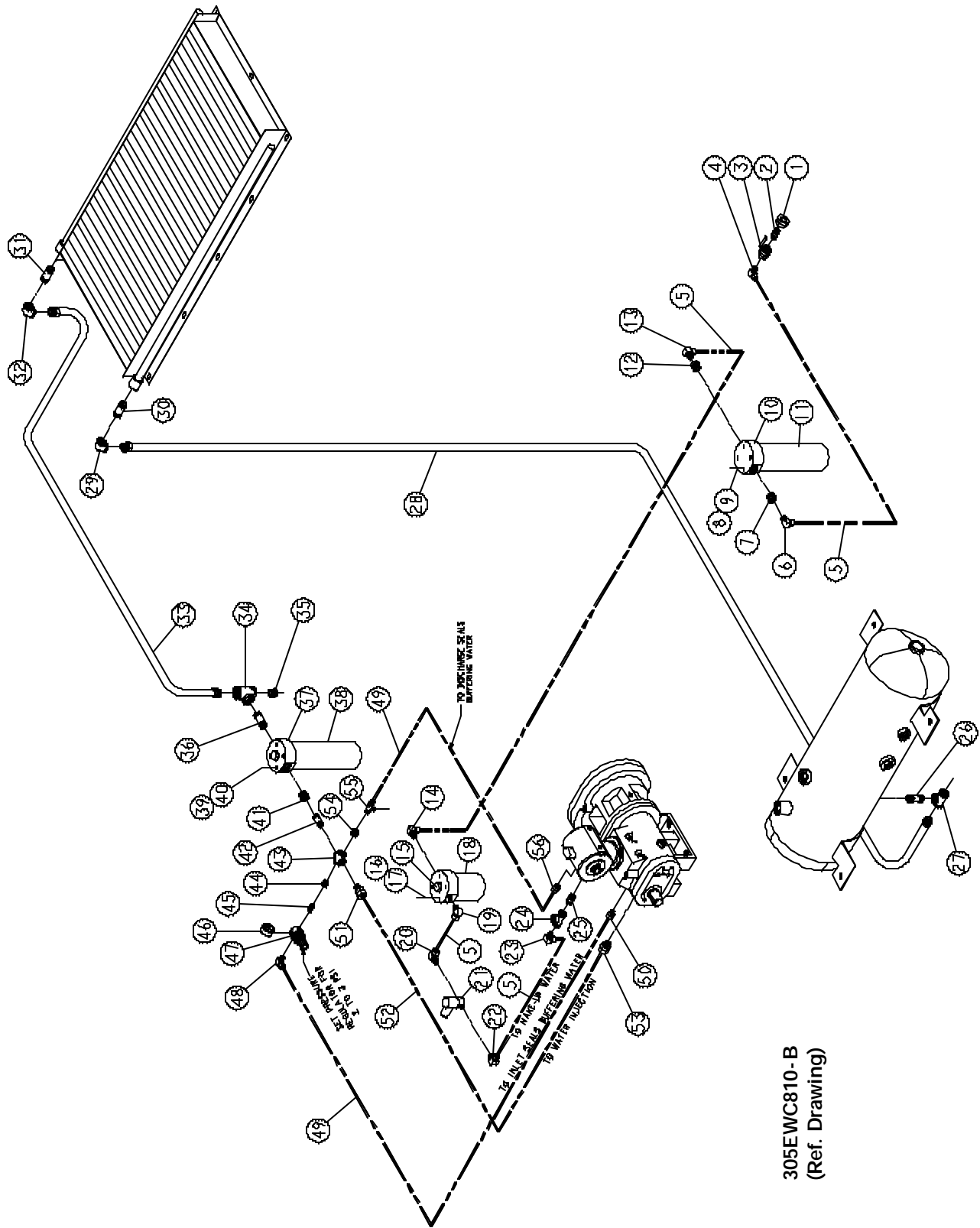

305EWC810-B
(Ref. Drawing)

Order by Part Number and Description. Reference Numbers are for your convenience only.

WATER PIPING GROUP

Ref. No.	Name of Part	Qty.	Part No.	Ref. No.	Name of Part	Qty.	Part No.
1	COUPLING-PIPE	1	64EB613	29	ELBOW-PIPE	1	64EB137
2	NIPPLE-PIPE (BRASS)	1	64EB618	30	NIPPLE-PIPE	1	64EB139
3	VALVE-BALL	1	90AR241	31	NIPPLE-PIPE	1	64EB651
4	ELBOW-TUBE	1	86E199	32	ELBOW-PIPE	1	64EB137
5	TUBE	10	85H4	33	HOSE	1	29Z373
6	ELBOW	1	86E64	34	TEE	1	64EB530
7	BUSHING-PIPE	1	64E71	35	BUSHING-PIPE	1	64E71
8	SCREW-FLANGED HD	4	75LM47	36	NIPPLE-PIPE	1	64EB52
9	WASHER	4	95A1	37	FILTER HOUSING	1	26C34
10	FILTER HOUSING	1	26C41	38	ELEMENT	1	2117902
11	CARTRIDGE, PHOSPHATE	1	2117903	39	WASHER	4	95A1
12	BUSHING-PIPE	1	64E71	40	SCREW-FLANGED HD	4	75LM47
13	ELBOW	1	86E64	41	BUSHING-PIPE (BRASS)	1	64EB524
14	ELBOW	1	86E65	42	NIPPLE-PIPE (BRASS)	1	64EB618
15	FILTER HOUSING	1	26C39	43	CROSS	1	64EB822
16	WASHER	4	95A1	44	BUSHING-PIPE	1	64E62
17	SCREW-FLANGED HD	4	75LM47	45	NIPPLE PIPE (BRASS)	1	64EB525
18	ELEMENT	1	2117901	46	PRESSURE GAUGE	1	27P320
19	ELBOW	1	86E65	47	REGULATOR	1	88H319
20	ELBOW	1	86E64	48	ELBOW-TUBE	1	86E60
21	VALVE-SOLENOID	1	91B110	49	TUBE	8	85H3
22	ELBOW	1	86E64	50	CONNECTOR	1	86E4
23	ELBOW-TUBE	1	86E199	51	CONNECTOR-TUBE	1	86E20
24	VALVE-CHECK	1	90J121	52	TUBE, 5/8 OD	3	85H6
25	NIPPLE-PIPE	1	63AP35	53	CONNECTOR-TUBE	1	86E20
26	NIPPLE-PIPE	1	64EB651	54	BUSHING-PIPE	1	64E62
27	TEE	1	64EB530	55	TEE-TUBE	1	2009284
28	HOSE	1	29Z374	56	CONNECTOR	1	86E4

CONTROL FITTING GROUP

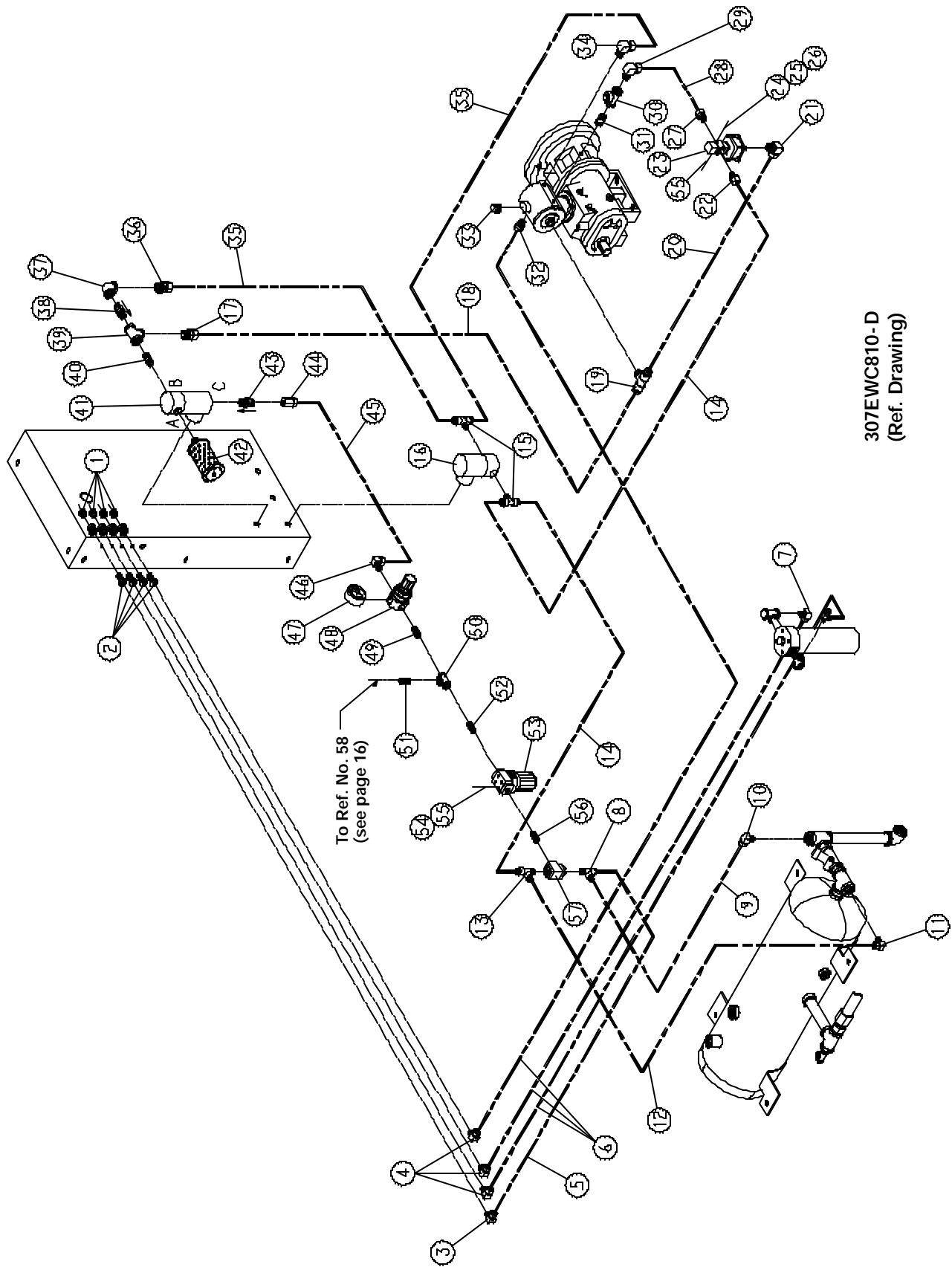

307EWC810-D
(Ref. Drawing)

Order by Part Number and Description. Reference Numbers are for your convenience only.

CONTROL FITTING GROUP

Ref. No.	Name of Part	Qty.	Part No.	Ref. No.	Name of Part	Qty.	Part No.
1	BUSHING-PIPE	4	64E28	30	VALVE-CHECK	1	90J120
2	COUPLING-PIPE	4	64EB368	31	NIPPLE	1	63Z85
3	ELBOW	1	86E64	32	CONNECTOR	1	86E4
4	ELBOW-TUBE	3	86E60	33	PLUG-SQHD PIPE	1	64AJ2
5	TUBE	6	85H4	34	ELBOW	1	86E64
6	TUBE	12	85H3	35	TUBE	6	85H4
7	ELBOW-TUBE	1	86E60	36	CONNECTOR-TUBE	1	86E9
8	TEE-TUBE	1	86E136	37	ELBOW-PIPE	1	64C37
9	TUBE	6	85H4	38	VALVE-CHECK	1	90AR261
10	ELBOW	1	86E64	39	TEE-PIPE	1	64G15
11	ELBOW	1	86E64	40	NIPPLE PIPE (BRASS)	1	64EB525
12	TUBE	6	85H4	41	VALVE-SOLENOID	1	91B149
13	TEE-TUBE	1	86E136	42	MUFFLER	1	43E4
14	TUBE	6	85H4	43	VALVE-CHECK	1	90AR261
15	TEE	2	86E122	44	CONNECTOR-TUBE	1	86E28
16	VALVE-SOLENOID	1	91B70				
17	CONNECTOR	1	86E4	45	TUBE	2	85H3
18	TUBE	1	85H3	46	ELBOW-TUBE	1	86E60
19	TEE-TUBE	1	86E119	47	PRESSURE GAUGE	1	27P321
20	TUBE	2	85H3	48	REGULATOR	1	88H292
21	ELBOW-TUBE	1	86E60	49	NIPPLE PIPE (BRASS)	1	64EB525
22	CONNECTOR-TUBE	1	86E9	50	TEE-PIPE	1	64G15
23	VALVE-CONTROL	1	90AR35	51	NIPPLE PIPE (BRASS)	1	64EB525
24	SCREW	2	655EC060	52	NIPPLE PIPE (BRASS)	1	64EB525
25	WASHER	2	95B1	53	FILTER-LINE	1	5L110
26	NUT	2	50B1	54	SCREW-SELF TAPPING	4	75LM215
27	CONNECTOR-TUBE	1	86E9	55	WASHER-PLAIN	6	95A1
28	TUBE	1	85H4	56	NIPPLE PIPE (BRASS)	1	64EB525
29	ELBOW	1	86E65	57	VALVE-CONTROL	1	90AR1006

CONTROL FITTING GROUP

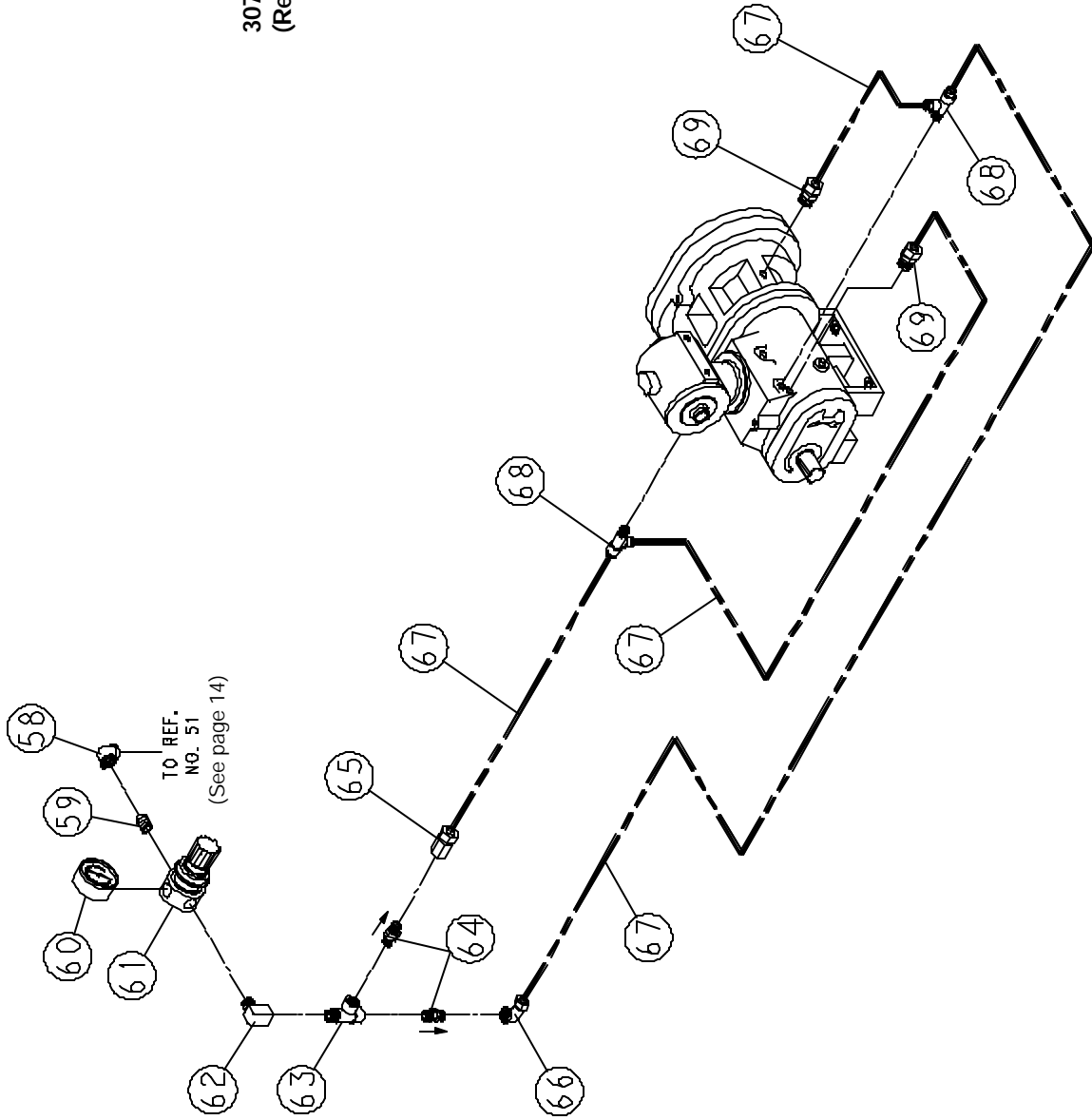

307EWC810-D
(Ref. Drawing)

Order by Part Number and Description. Reference Numbers are for your convenience only.

CONTROL FITTING GROUP

Ref. No.	Name of Part	Qty.	Part No.
58	ELBOW-PIPE	1	64C37
59	NIPPLE PIPE (BRASS)	2	64EB525
60	PRESSURE GAUGE	1	27P320
61	REGULATOR	1	88H318
62	ELBOW-PIPE ST	1	64D55
63	TEE	1	2009699
64	VALVE-CHECK	2	90AR261
65	CONNECTOR-TUBE	1	86E28
66	ELBOW-TUBE	1	86E193
67	TUBE	8	85H3
68	TEE-TUBE	2	86E136
69	CONNECTOR	2	86E4

DRAIN PIPING

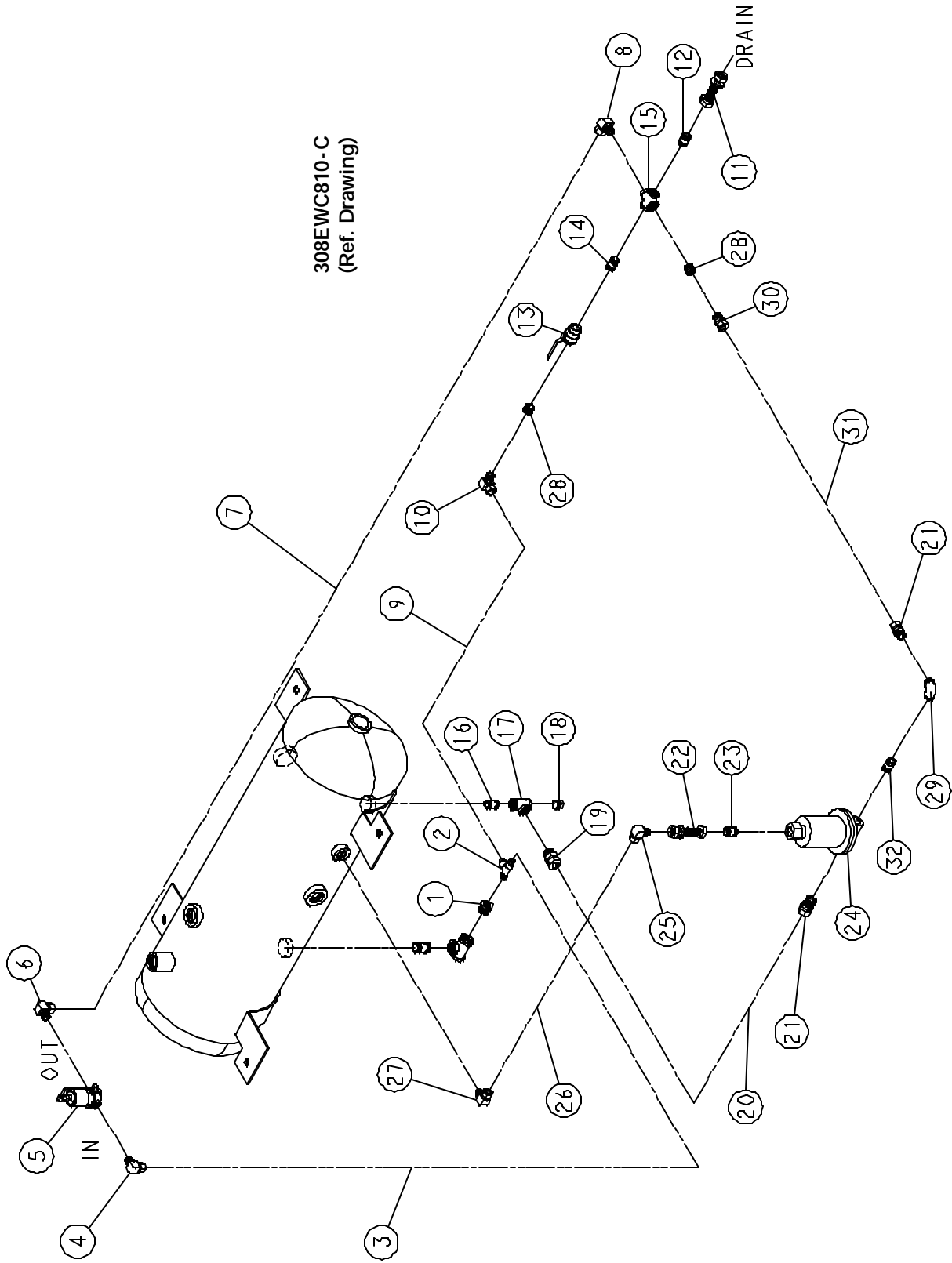

308EWC810-C
(Ref. Drawing)

Order by Part Number and Description. Reference Numbers are for your convenience only.

DRAIN PIPING

Ref. No.	Name of Part	Qty.	Part No.
1	BUSHING-PIPE	1	64E71
2	TEE-TUBE	1	86E136
3	TUBE	4	85H4
4	ELBOW	1	86E65
5	VALVE-SOLENOID	1	91B146
6	ELBOW	1	86E65
7	TUBE	6	85H4
8	ELBOW-TUBE	1	86E199
9	TUBE	6	85H4
10	ELBOW	1	86E65
11	COUPLING-PIPE	1	64EB613
12	NIPPLE-PIPE (BRASS)	1	64EB618
13	VALVE-BALL	1	90AR241
14	NIPPLE-PIPE	1	63AP35
15	CROSS	1	64EB822
16	NIPPLE	1	63AP35
17	TEE PIPE	1	64EB429
18	PLUG-SQHD PIPE	1	64AJ4
19	CONNECTOR-TUBE	1	86M8
20	TUBE	4	85H4
21	CONNECTOR-TUBE	2	86M8
22	COUPLING-PIPE	1	64EB613
23	NIPPLE-PIPE (BRASS)	1	64EB618
24	TRAP-STAINLESS	1	83C93
25	ELBOW-TUBE	1	86E199
26	TUBE	1	85H4
27	ELBOW-TUBE	1	86E199
28	BUSHING PIPE	2	64EB469
29	ELBOW-PIPE	1	64EB428
30	CONNECTOR-TUBE	1	86E10
31	TUBE	2	85H4
32	NIPPLE-PIPE	1	63AP35

CONTROLLER ASSEMBLY - FULL VOLTAGE STARTERS

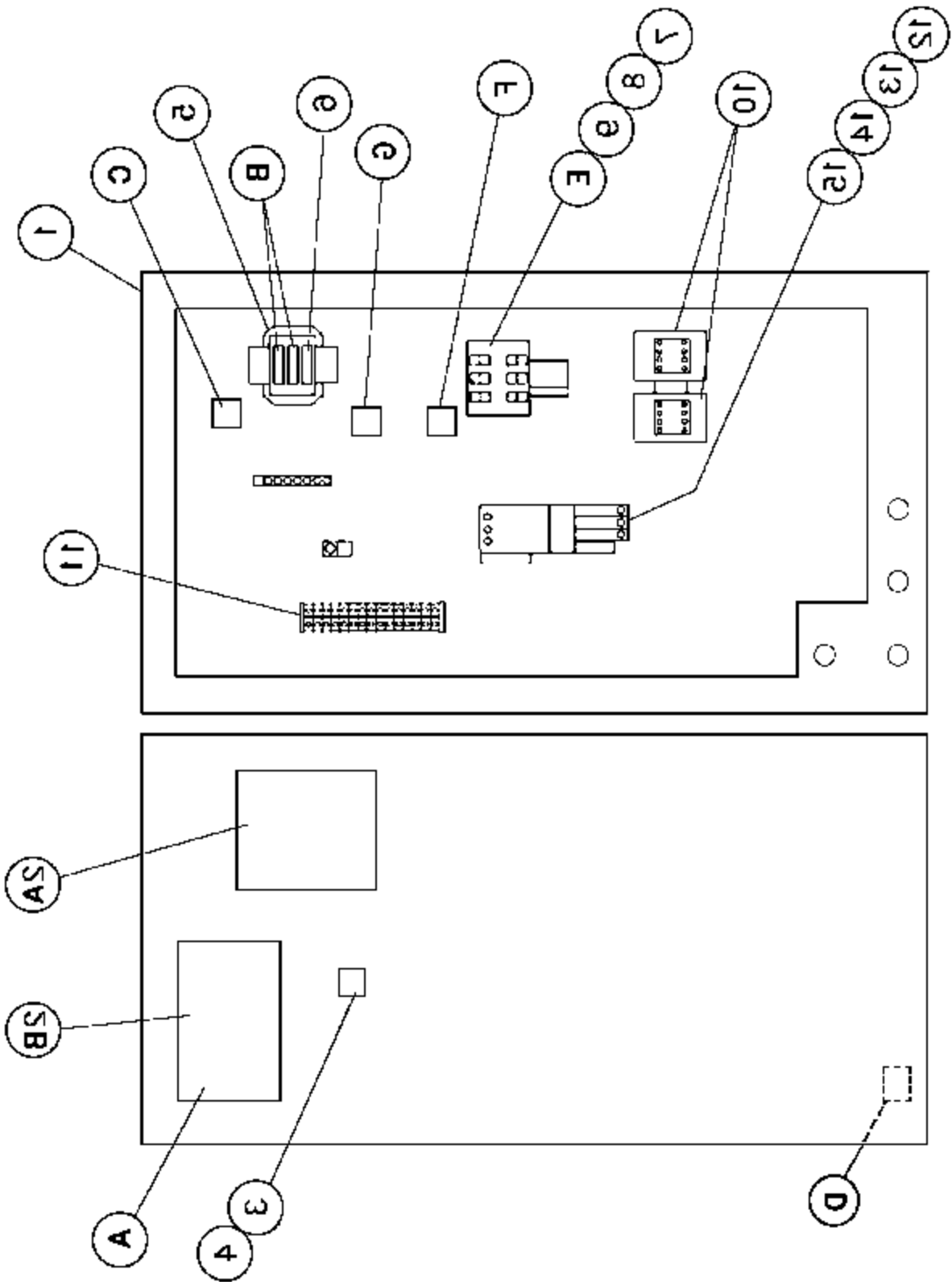

Refer to pages 21 through 23 for Part Number References.

CONTROLLER ASSEMBLY - FULL VOLTAGE STARTERS
20 H.P. UNITS

	Qty.	200V	230V	460V	575V
ASSEMBLED PANEL: NEMA12	1	304EWC466	301EWC466	300EWC466	308EWC466
ASSEMBLED PANEL: NEMA 4	1	314EWC466	311EWC466	310EWC466	318EWC466
1 ELECTRICAL CONTROL ENCLOSURE	1	300EWC179	300EWC179	300EWC179	300EWC179
2A ELECTRICAL CONTROL ASSEMBLY	1	300EWC1173	300EWC1173	300EWC1173	300EWC1173
2B KEYPAD ASSEMBLY	1	301EWC375	301EWC375	301EWC375	301EWC375
3 OPERATOR, 22mm PUSH-PULL E-STOP	1	24CA2907	24CA2907	24CA2907	24CA2907
4 CONTACT BLOCK E22B1 SPNC	1	24CA2908	24CA2908	24CA2908	24CA2908
5 CONTROL TRANSFORMER	1	24CA4451	24CA4451	24CA4451	24CA4451
6 FUSE, TRANSFORMER SECONDARY	1	24CA3725	24CA3725	24CA3725	24CA3725
7 FUSE HOLDER	1	24CA4098	24CA4098	24CA4098	24CA4098
8 STARTER, FAN MOTOR	1	24CA4132	24CA4132	24CA4132	24CA4132
9 COIL, FAN MOTOR STARTER	1	2115950	2115950	2115950	2115950
10 OVERLOAD RELAY	2	24CA4086	24CA4086	24CA4086	24CA4086
11 TERMINAL BLOCK	7	24CA2633	24CA2633	24CA2633	24CA2633
12 STARTER, MAIN MOTOR	1	24CA3881	24CA4142	24CA4137	24CA4137
13 COIL, MAIN MOTOR STARTER	1	2116555	2116124	2115950	2115950
14 OVERLOAD RELAY	1	24CA4086	24CA4087	24CA4086	24CA4086
15 RELAY, 3 POLE	1	24CA3259	24CA3258	24CA2609	24CA2609
A FUSE, CONTROL BOARD	1	24CA2932	24CA2932	24CA2932	24CA2932
B FUSE, TRANSFORMER PRIMARY	2	24CA2786	24CA2785	24CA2782	24CA2781
C DECAL, PRIMARY FUSE	1	265AUX077	264AUX077	261AUX077	260AUX077
D DECAL, VOLTAGE	1	69F50	69F51	69F52	69F60
E FUSE, FAN MOTOR	3	24CA4095	24CA4095	24CA4092	24CA4092
F DECAL, FAN FUSES	1	313AUX077	313AUX077	310AUX077	310AUX077
G DECAL, SECONDARY FUSE	1	297AUX077	297AUX077	297AUX077	297AUX077

Refer to page 20 for reference drawing.

CONTROLLER ASSEMBLY - FULL VOLTAGE STARTERS
25 H.P. UNITS

	Qty.	200V	230V	460V	575V
ASSEMBLED PANEL: NEMA12	1	304EWC466	302EWC466	301EWC466	308EWC466
ASSEMBLED PANEL: NEMA 4	1	314EWC466	312EWC466	311EWC466	318EWC466
1 ELECTRICAL CONTROL ENCLOSURE	1	300EWC179	300EWC179	300EWC179	300EWC179
2A ELECTRICAL CONTROL ASSEMBLY	1	300EWC1173	300EWC1173	300EWC1173	300EWC1173
2B KEYPAD ASSEMBLY	1	301EWC375	301EWC375	301EWC375	301EWC375
3 OPERATOR, 22mm PUSH-PULL E-STOP	1	24CA2907	24CA2907	24CA2907	24CA2907
4 CONTACT BLOCK E22B1 SPNC	1	24CA2908	24CA2908	24CA2908	24CA2908
5 CONTROL TRANSFORMER	1	24CA4451	24CA4451	24CA4451	24CA4451
6 FUSE, TRANSFORMER SECONDARY	1	24CA3725	24CA3725	24CA3725	24CA3725
7 FUSE HOLDER	1	24CA4098	24CA4098	24CA4098	24CA4098
8 STARTER, FAN MOTOR	1	24CA4132	24CA4132	24CA4132	24CA4132
9 COIL, FAN MOTOR STARTER	1	2115950	2115950	2115950	2115950
10 OVERLOAD RELAY	2	24CA4086	24CA4086	24CA4086	24CA4086
11 TERMINAL BLOCK	7	24CA2633	24CA2633	24CA2633	24CA2633
12 STARTER, MAIN MOTOR	1	24CA3881	24CA3881	24CA4142	24CA4137
13 COIL, MAIN MOTOR STARTER	1	2116555	2116555	2116124	2115950
14 OVERLOAD RELAY	1	24CA4086	24CA4086	24CA4087	24CA4086
15 RELAY, 3 POLE	1	24CA3259	24CA3259	24CA3258	24CA2609
A FUSE, CONTROL BOARD	1	24CA2932	24CA2932	24CA2932	24CA2932
B FUSE, TRANSFORMER PRIMARY	2	24CA2786	24CA2785	24CA2782	24CA2781
C DECAL, PRIMARY FUSE	1	265AUX077	264AUX077	261AUX077	260AUX077
D DECAL, VOLTAGE	1	69F50	69F51	69F52	69F60
E FUSE, FAN MOTOR	3	24CA4095	24CA4095	24CA4092	24CA4092
F DECAL, FAN FUSES	1	313AUX077	313AUX077	310AUX077	310AUX077
G DECAL, SECONDARY FUSE	1	297AUX077	297AUX077	297AUX077	297AUX077

Refer to page 20 for reference drawing.

CONTROLLER ASSEMBLY - FULL VOLTAGE STARTERS
30 H.P. UNITS

	Qty.	200V	230V	460V	575V
ASSEMBLED PANEL: NEMA12	1	304EWC466	302EWC466	301EWC466	309EWC466
ASSEMBLED PANEL: NEMA 4	1	314EWC466	312EWC466	311EWC466	319EWC466
1 ELECTRICAL CONTROL ENCLOSURE	1	300EWC179	300EWC179	300EWC179	300EWC179
2A ELECTRICAL CONTROL ASSEMBLY	1	300EWC1173	300EWC1173	300EWC1173	300EWC1173
2B KEYPAD ASSEMBLY	1	301EWC375	301EWC375	301EWC375	301EWC375
3 OPERATOR, 22mm PUSH-PULL E-STOP	1	24CA2907	24CA2907	24CA2907	24CA2907
4 CONTACT BLOCK E22B1 SPNC	1	24CA2908	24CA2908	24CA2908	24CA2908
5 CONTROL TRANSFORMER	1	24CA4451	24CA4451	24CA4451	24CA4451
6 FUSE, TRANSFORMER SECONDARY	1	24CA3725	24CA3725	24CA3725	24CA3725
7 FUSE HOLDER	1	24CA4098	24CA4098	24CA4098	24CA4098
8 STARTER, FAN MOTOR	1	24CA4132	24CA4132	24CA4132	24CA4132
9 COIL, FAN MOTOR STARTER	1	2115950	2115950	2115950	2115950
10 OVERLOAD RELAY	2	24CA4086	24CA4086	24CA4086	24CA4086
11 TERMINAL BLOCK	7	24CA2633	24CA2633	24CA2633	24CA2633
12 STARTER, MAIN MOTOR	1	24CA3881	24CA3881	24CA4142	24CA4142
13 COIL, MAIN MOTOR STARTER	1	2116555	2116555	2116124	2116124
14 OVERLOAD RELAY	1	24CA4086	24CA4086	24CA4087	24CA4087
15 RELAY, 3 POLE	1	24CA3259	24CA3259	24CA3258	24CA3258
A FUSE, CONTROL BOARD	1	24CA2932	24CA2932	24CA2932	24CA2932
B FUSE, TRANSFORMER PRIMARY	2	24CA2786	24CA2785	24CA2782	24CA2781
C DECAL, PRIMARY FUSE	1	265AUX077	264AUX077	261AUX077	260AUX077
D DECAL, VOLTAGE	1	69F50	69F51	69F52	69F60
E FUSE, FAN MOTOR	3	24CA4095	24CA4095	24CA4092	24CA4092
F DECAL, FAN FUSES	1	313AUX077	313AUX077	310AUX077	310AUX077
G DECAL, SECONDARY FUSE	1	297AUX077	297AUX077	297AUX077	297AUX077

Refer to page 20 for reference drawing.

CONTROLLER ASSEMBLY - LESS MAIN STARTER

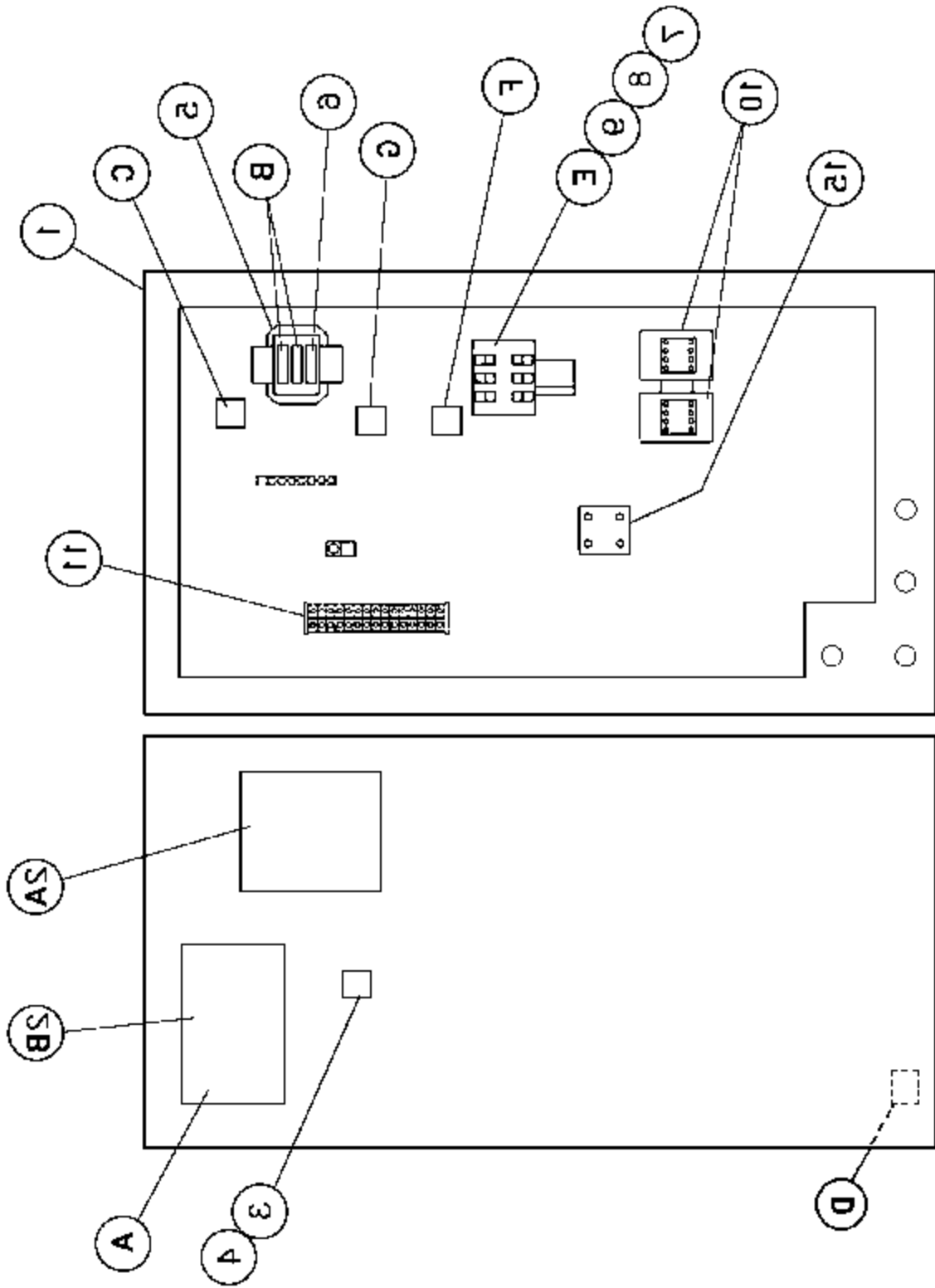

Refer to page 25 for Part Number References.

CONTROLLER ASSEMBLY - LESS MAIN STARTER

	Qty.	200V	230V	460V	575V
ASSEMBLED PANEL: NEMA12	1	333EWC466	332EWC466	332EWC466	335EWC466
ASSEMBLED PANEL: NEMA 4	1	337EWC466	336EWC466	336EWC466	339EWC466
1 ELECTRICAL CONTROL ENCLOSURE	1	300EWC179	300EWC179	300EWC179	300EWC179
2A ELECTRICAL CONTROL ASSEMBLY	1	300EWC1173	300EWC1173	300EWC1173	300EWC1173
2B KEYPAD ASSEMBLY	1	301EWC375	301EWC375	301EWC375	301EWC375
3 OPERATOR, 22mm PUSH-PULL E-STOP	1	24CA2907	24CA2907	24CA2907	24CA2907
4 CONTACT BLOCK E22B1 SPNC	1	24CA2908	24CA2908	24CA2908	24CA2908
5 CONTROL TRANSFORMER	1	24CA4451	24CA4451	24CA4451	24CA4451
6 FUSE, TRANSFORMER SECONDARY	1	24CA3725	24CA3725	24CA3725	24CA3725
7 FUSE HOLDER	1	24CA4098	24CA4098	24CA4098	24CA4098
8 STARTER, FAN MOTOR	1	24CA4132	24CA4132	24CA4132	24CA4132
9 COIL, FAN MOTOR STARTER	1	2115950	2115950	2115950	2115950
10 OVERLOAD RELAY	2	24CA4086	24CA4086	24CA4086	24CA4086
11 TERMINAL BLOCK	8	24CA2633	24CA2633	24CA2633	24CA2633
15 RELAY, 3 POLE	1	24CA3896	24CA3896	24CA3896	24CA3896
A FUSE, CONTROL BOARD	1	24CA2932	24CA2932	24CA2932	24CA2932
B FUSE, TRANSFORMER PRIMARY	2	24CA2786	24CA2785	24CA2782	24CA2781
C DECAL, PRIMARY FUSE	1	265AUX077	264AUX077	261AUX077	260AUX077
D DECAL, VOLTAGE	1	69F50	69F51	69F52	69F60
E FUSE, FAN MOTOR	3	24CA4095	24CA4095	24CA4092	24CA4092
F DECAL, FAN FUSES	1	313AUX077	313AUX077	310AUX077	310AUX077
G DECAL, SECONDARY FUSE	1	297AUX077	297AUX077	297AUX077	297AUX077

Refer to page 24 for reference drawing.

Order by Part Number and Description. Reference Numbers are for your convenience only.

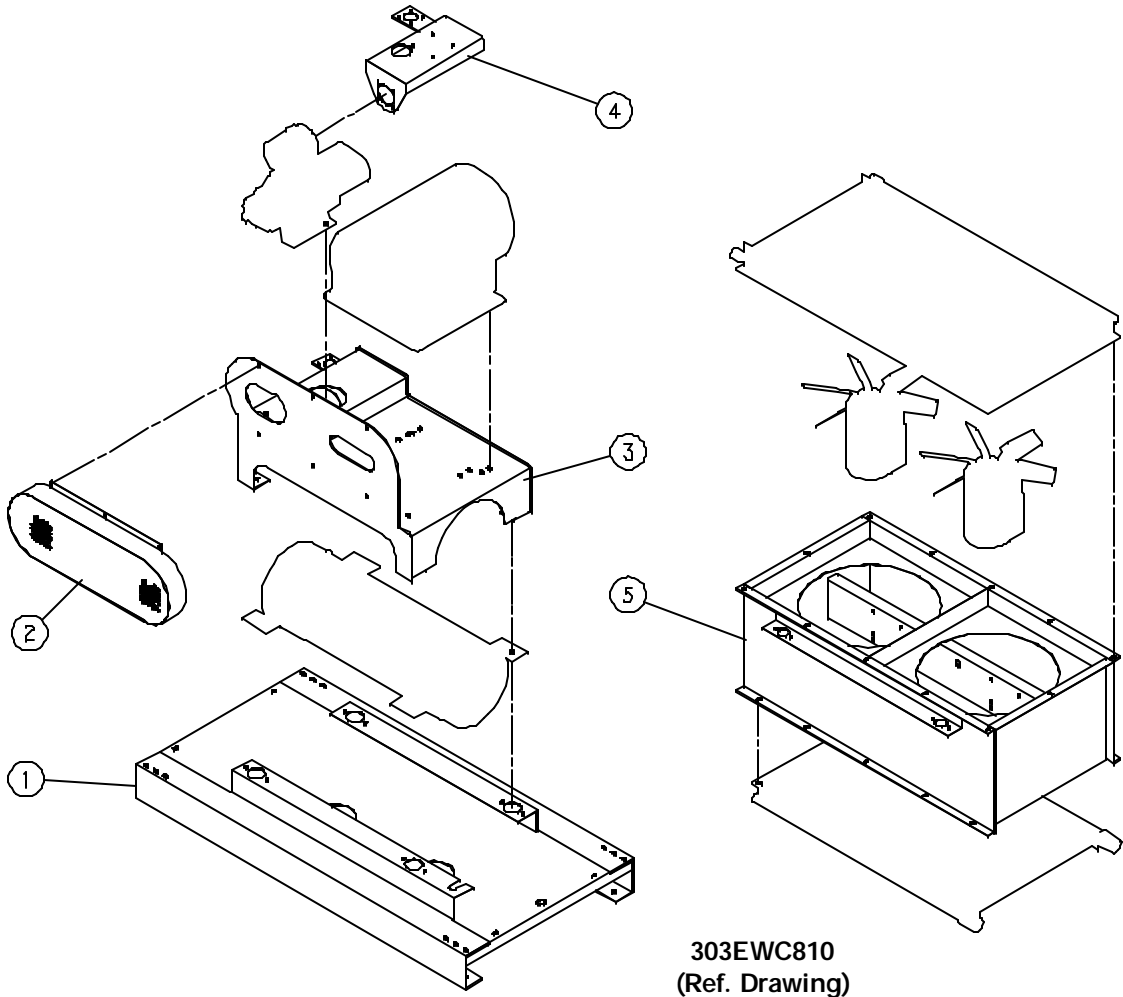

COMMON FABRICATED PARTS

Ref. No.	Name of Part	Qty.	Part No.
1	BASE	1	300EWC285
2	GUARD-DRIVE	1	300EWC120
3	SUPPORT	1	300EWC165
4	BRACKET-FILTER	1	300EWC389
5	SHROUD	1	300EWC647

Order by Part Number and Description. Reference Numbers are for your convenience only.

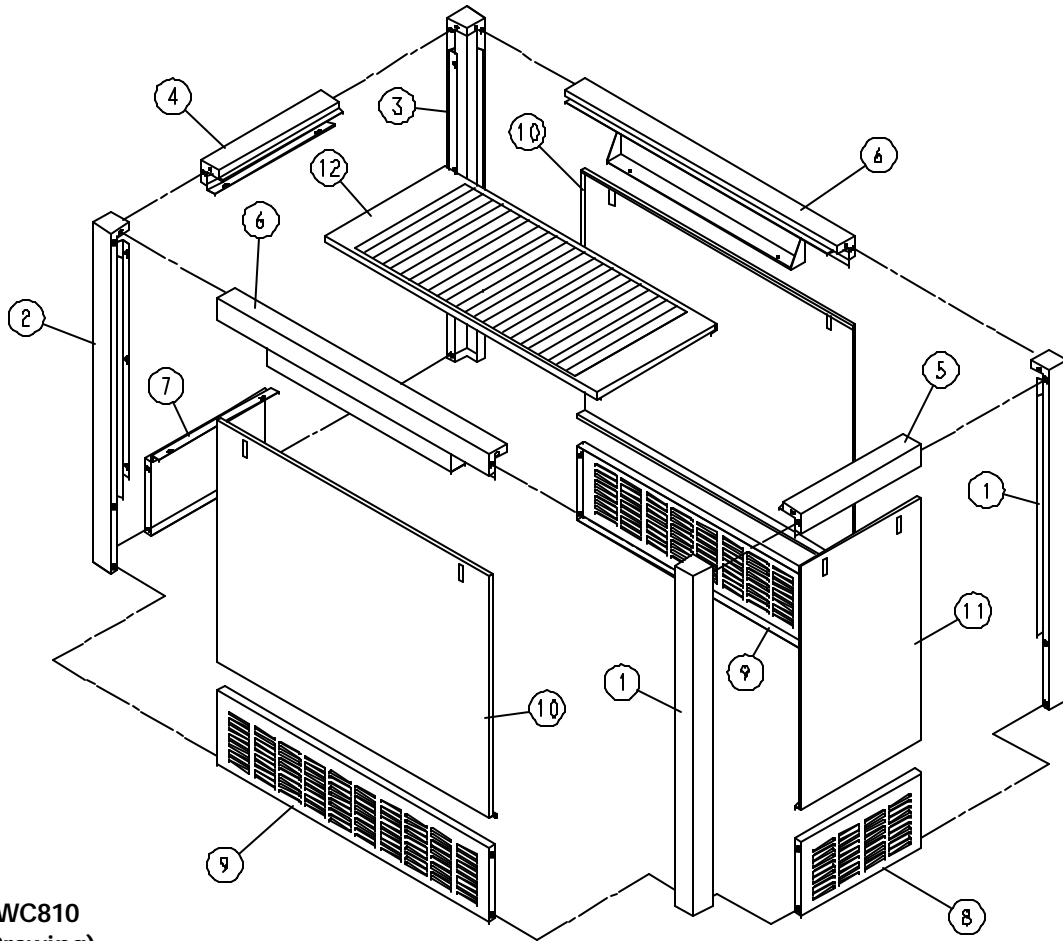

ENCLOSURE GROUP

Ref. No.	Name of Part	Qty.	Part No.
1	POST	2	300EWC313
2	POST	1	301EWC313
3	POST	1	302EWC313
4	FRAME	1	302EWC314
5	FRAME	1	301EWC314
6	FRAME	2	300EWC314
7	PANEL	1	303EWC216
8	PANEL	1	304EWC216
9	PANEL	2	302EWC216
10	PANEL	2	300EWC216
11	PANEL	1	301EWC216
12	GRILLE	1	300EWC736

Order by Part Number and Description. Reference Numbers are for your convenience only.

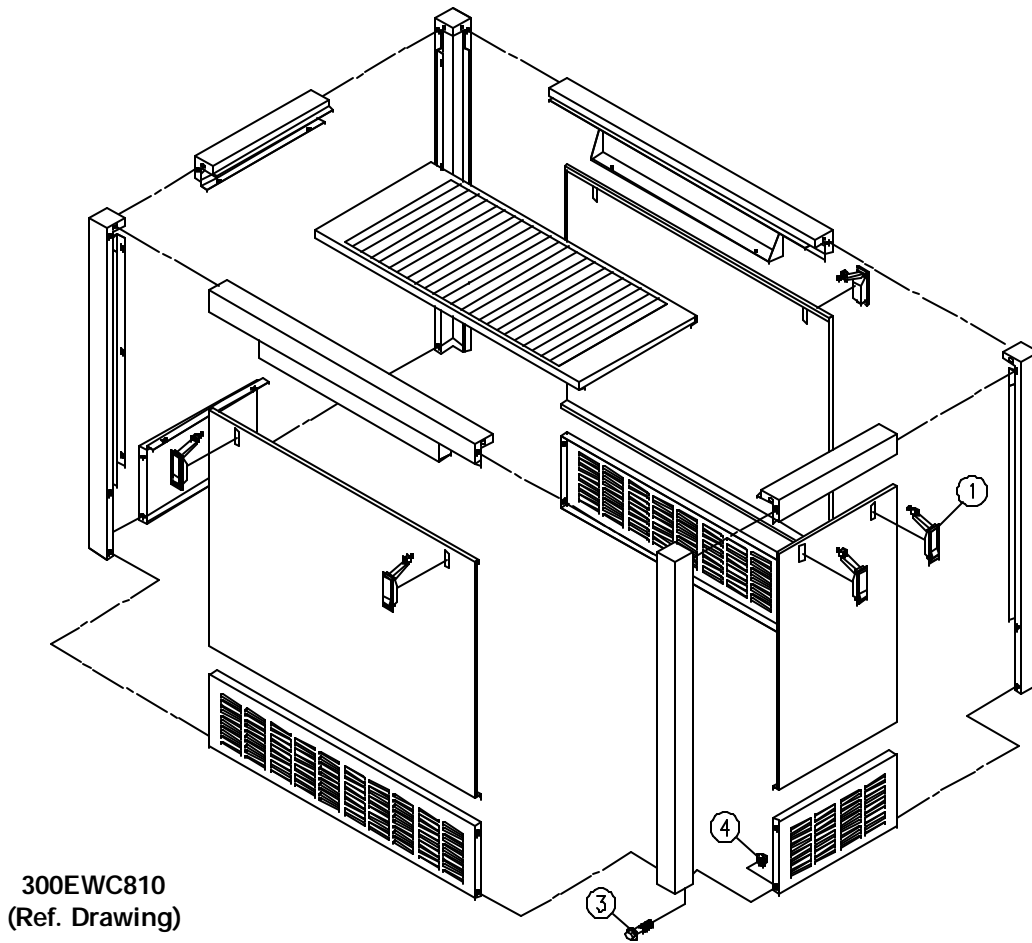

ENCLOSURE HARDWARE

Ref. No.	Name of Part	Qty.	Part No.
1	LATCH	6	31D58
3	SCREW-FLANGED	58	75LM51
4	NUT-FLANGED	58	50AW5
*	SEAL	36	32E12

* Not shown.

IDENTIFICATION AND INSTRUCTION GROUP

Name of Part	Qty.	Part No.
DECAL, WARNING-ELECTRICAL SHOCK	1	216EAQ077
DECAL, WARNING-READ OPERATOR MANUAL	1	305EWC077
DECAL, CAUTION USE FLOOR PLATE	1	221EAQ077
DECAL, DANGER-HIGH VOLTS	2	301EWC077
DECAL, WARNING ELECTRICAL SHOCK	1	213EAQ077
DECAL, WARNING SEE WIRING DIAGRAM	1	222EAQ077
DECAL, ROTORCHAMP	2	310EBA077
DECAL, OPERATION & MAINTENANCE	1	305EWC077
DECAL, CHAMPION (LARGE)	2	308EBA077
DECAL, CHAMPION (SMALL)	4	309EWC077
DECAL, CAUTION- DO NOT LIFT	1	208EAQ077
DECAL, WARNING UNIT CAN AUTOMATICALLY START	1	207EAQ077
DECAL, DANGER DO NOT BREATH DISCHARGE AIR	3	206EAQ077
PLATE- DATA	1	201EWD454
PLATE- DATA	1	200EWD454
DECAL, WARNING	2	227EAQ077
DECAL, STRIPE - PLAIN	1	204EWD077
DECAL, LUBRICANT ROTORLUB 800	1	307EWC077
DECAL, OIL FREE	2	202EWD077
DECAL, DANGER-AIR/WATER UNDER PRESSURE	1	300EWC077
DECAL, WATER SEPARATOR	1	206EWD077
DECAL, NOTICE - USE CHAMPION PARTS	1	308EWC077
DECAL, STRIPE - PLAIN	2	204EWD077
DECAL, WARNING ROTATING MACHINERY	1	211EAQ077
DECAL, ROTATION ARROW	2	204EBE077
RIVET	4	70E13
SEALANT	1	25BC448

DRIVE GROUP

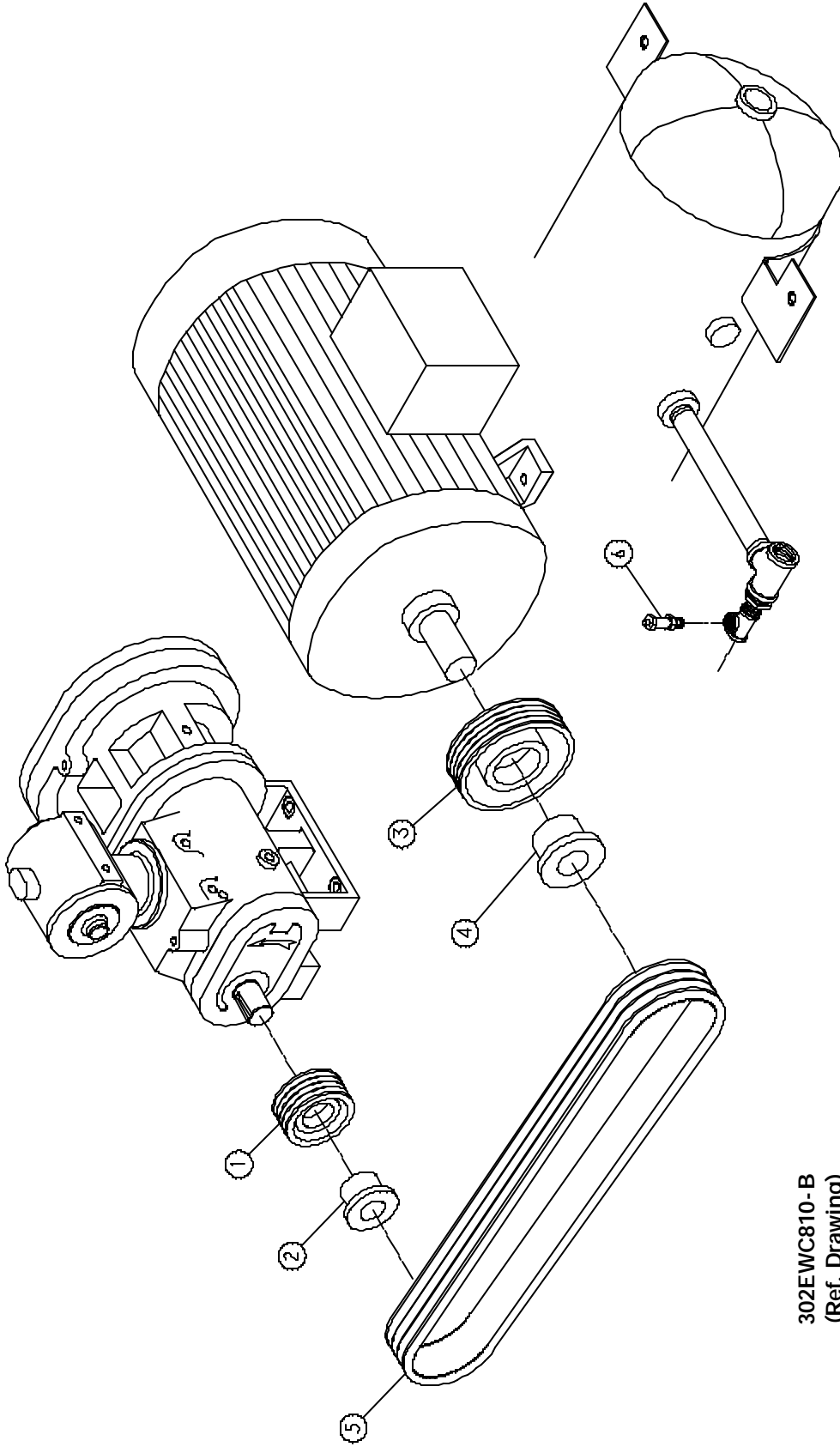

302EWC810-B
(Ref. Drawing)

Refer to pages 31 and 32 for Part Number References.

DRIVE GROUP

Ref. No.	Name of Part	Qty.	20 HP		20 HP		20 HP	
			100 PSI Part No.	150 PSI Part No.	125 PSI Part No.	150 PSI Part No.		
1	SHEAVE	1	73M43V60	73M43V65	73M43V65	73M43V65	73M43V65	
2	BUSHING-HUB	1	22F24SK	22F24SK	22F24SK	22F24SK	22F24SK	
3	SHEAVE	1	73M43V50	73M43V47	73M43V47	73M43V41	73M43V41	
4	BUSHING-HUB	1	22F26SDS	22F26SDS	22F26SDS	22F26SH	22F26SH	
5	SET-BELT 4 PIECE	1	300EWC811	300EWC811	300EWC811	300EWC811	300EWC811	
6	VALVE-PRESSURE RELIEF	1	90AR661	90AR662	90AR662	90AR663	90AR663	

Ref. No.	Name of Part	Qty.	25 HP (ODP)		25 HP (ODP)		25 HP (ODP)	
			100 PSI Part No.	125 PSI Part No.	125 PSI Part No.	150 PSI Part No.		
1	SHEAVE	1	73M43V53	73M43V65	73M43V65	73M43V65	73M43V65	
2	BUSHING-HUB	1	22F24SDS	22F24SK	22F24SK	22F24SK	22F24SK	
3	SHEAVE	1	73M43V56	73M43V60	73M43V60	73M43V53	73M43V53	
4	BUSHING-HUB	1	22F26SDS	22F26SK	22F26SK	22F26SDS	22F26SDS	
5	SET-BELT 4 PIECE	1	300EWC811	301EWC811	301EWC811	301EWC811	301EWC811	
6	VALVE-PRESSURE RELIEF	1	90AR661	90AR662	90AR662	90AR663	90AR663	

NOTE: These parts are used on packages with 25 HP O.D.P. motors.

Ref. No.	Name of Part	Qty.	25 HP (TEFC)		25 HP (TEFC)		25 HP (TEFC)	
			100 PSI Part No.	125 PSI Part No.	125 PSI Part No.	150 PSI Part No.		
1	SHEAVE	1	73M43V53	73M43V65	73M43V65	73M43V65	73M43V65	
2	BUSHING-HUB	1	22F24SDS	22F24SK	22F24SK	22F24SK	22F24SK	
3	SHEAVE	1	73M43V56	73M43V60	73M43V60	73M43V53	73M43V53	
4	BUSHING-HUB	1	22F30SDS	22F30SK	22F30SK	22F30SDS	22F30SDS	
5	SET-BELT 4 PIECE	1	300EWC811	301EWC811	301EWC811	301EWC811	301EWC811	
6	VALVE-PRESSURE RELIEF	1	90AR661	90AR662	90AR662	90AR663	90AR663	

NOTE: These parts are used on packages with 25 HP T.E.F.C. motors.

Refer to page 30 for reference drawing.

DRIVE GROUP

Ref. No.	Name of Part	Qty.	30 HP 100 PSI Part No.	30 HP 125 PSI Part No.	30 HP 150 PSI Part No.
1	SHEAVE	1	73M43V47	73M43V50	73M43V50
2	BUSHING-HUB	1	22F24SDS	22F24SDS	22F24SDS
3	SHEAVE	1	73M43V60	73M43V56	73M43V50
4	BUSHING-SHEAVE	1	22F30SK	22F30SDS	22F30SDS
5	SET-BELT 4 PIECE	1	300EWC811	300EWC811	300EWC811
6	VALVE-PRESSURE RELIEF	2	90AR661	90AR662	90AR663

Refer to page 30 for reference drawing.

**MOTOR GROUP
MAIN DRIVE MOTORS
FULL VOLTAGE**

Name of Part	20 HP Part No.	25 HP Part No.	30 HP Part No.
OPEN DRIP PROOF (60 HZ - ODP)			
MOTOR, 200V	24CA4437	24CA4438	24CA4439
MOTOR, 230V / 460V	24CA4440	24CA4441	24CA4442
MOTOR, 575V	24CA4443	24CA4444	24CA4445
MOTOR MOUNTING BASE	24AZ21	24AZ22	24AZ23
OPEN DRIP PROOF (60 HZ - ODP - HIGH EFFICIENCY)			
MOTOR, 200V	24CA4468	24CA4469	24CA4470
MOTOR, 230V / 460V	24CA4471	24CA4472	24CA4473
MOTOR, 575V	24CA4474	24CA4475	24CA4476
MOTOR MOUNTING BASE	24AZ21	24AZ22	24AZ23
TOTALLY ENCLOSED FAN COOLED (60 HZ - TEFC)			
MOTOR, 200V	24CA4486	24CA4487	24CA4488
MOTOR, 230V / 460V	24CA4490	24CA4491	24CA4492
MOTOR, 575V	24CA4493	24CA4494	24CA4495
MOTOR MOUNTING BASE	24AZ22	24AZ23	24AZ24
TOTALLY ENCLOSED FAN COOLED (60 HZ - TEFC - HIGH EFFICIENCY)			
MOTOR, 200V	24CA4477	24CA4478	24CA4479
MOTOR, 230V / 460V	24CA4480	24CA4481	24CA4482
MOTOR, 575V	24CA4483	24CA4484	24CA4485
MOTOR MOUNTING BASE	24AZ22	24AZ23	24AZ24
MOTORS (FAN MOTOR - 2 REQUIRED) (60 HZ - TEFC)			
VOLTAGE	FAN MOTOR		
200	24CA4446		
230/460	24CA4447		
575	24CA4448		

OVERLOAD RELAY HEATER CONVERSION LISTING

Refer to Motor Nameplate "Amperage" and Decal in Control Panel for Selection of Overload Relay Heater Packs.

CUTLER-HAMMER PART NUMBER	CHAMPION PART NUMBER
H2002B	24CA4101
H2003B	24CA4102
H2004B	24CA4103
H2005B	24CA4104
H2006B	24CA4105
H2007B	24CA4106
H2008B	24CA4107
H2009B	24CA4108
H2010B	24CA4109
H2011B	24CA4110
H2012B	24CA4111
H2013B	24CA4112
H2014B	24CA4113
H2015B	24CA4114
H2016B	24CA4115
H2017B	24CA4116
H2018	24CA2924
H2019	24CA2925
H2020	24CA2926
H2021	24CA2927
H2022	24CA2893
H2023	24CA2894
H2024	24CA2928

REPAIR KITS

Name of Part	Qty.	Part No.
ROUTINE MAINTENANCE KIT (4000 HRS.) (Includes next four items)		304EWC6013
ELEMENT (AIR FILTER)	2	2117900
ELEMENT (MAKE-UP WATER FILTER)	4	2117901
ELEMENT (RECIRCULATING WATER FILTER)	4	2117902
CARTRIDGE, PHOSPHATE WATER TREATMENT	2	2117903
ELECTRICAL/MECHANICAL CONTROL KIT (Includes next nine items)		301EWC6013
VALVE-SOLENOID	1	91B149
VALVE-SOLENOID	1	91B146
VALVE-SOLENOID	1	91B70
VALVE-SOLENOID	1	91B110
SWITCH	1	300EWC375
SWITCH-VACUUM	1	88H195
PROBE-ELECTRICAL	1	21D264
TRANSDUCER-PRESSURE	3	88H242
DISC-COUPLING	2	2117158
DRIVE BELT SETS (4 BELTS PER SET):		
20 HP (100, 125 & 150 PSI MACHINES)	1	300EWC811
25 HP (100 PSI MACHINES)	1	300EWC811
25 HP (125 & 150 PSI MACHINES)	1	301EWC811
30 HP (100, 125 & 150 PSI MACHINES)	1	300EWC811
CONTROL VALVE (90AR35) REPAIR KIT, WITH DIAPHRAGM	1	2109652
MISCELLANEOUS REPAIR ITEMS:		
WATER TREATMENT CARTRIDGE HOUSING	1	26C41
MAKE-UP WATER FILTER HOUSING	1	26C39
RECIRCULATING WATER FILTER HOUSING	1	26C34
O-RING, SHELL (FOR 26C34)	1	2116644
O-RING, COVER NUT (FOR 26C34)	1	2116645
O-RING, GASKET SEAL (FOR 26C34)	1	2116646
CONTROL AIR LINE FILTER	1	5L110
ELEMENT (FOR 5L110)	1	2109620
O-RING AND GASKET (FOR 5L110)	1	2116000
TOUCH-UP PAINT		200EWD6003
1 QUART CAN		28H8
LUBRICANT		
5 GALLON PAIL - ROTORLUB 800		28H188



For additional information, service or spare parts, contact your local representative or Champion, Customer Service Department,

1301 N. Euclid Ave.

Princeton, IL 61356

Telephone: (815) 875-3321

Fax: (815) 872-0421

Sales and Service in all major cities.

Specifications subject to change without notice.
Copyright 1998 Champion

Litho in U.S.A.