



GARDNER DENVER™



13-10-520
Version: 08
September 14, 2012

**ELECTRA-SAVER®
STATIONARY BASE-MOUNTED
COMPRESSOR**

AUTO SENTRY® -- ES+ CONTROLS

MODEL

EAQ99Q – 125, 150, 200 HP

PARTS LIST

MAINTAIN COMPRESSOR RELIABILITY AND PERFORMANCE WITH GENUINE GARDNER DENVER® COMPRESSOR PARTS AND SUPPORT SERVICES

Gardner Denver® Compressor genuine parts, manufactured to design tolerances, are developed for optimum dependability – specifically for Gardner Denver compressor systems. Design and material innovations are the result of years of experience with hundreds of different compressor applications. Reliability in materials and quality assurance is incorporated in our genuine replacement parts.

Your authorized Gardner Denver Compressor distributor offers the entire backup you'll need. A worldwide network of authorized distributors provides the finest product support in the air compressor industry.

Your authorized distributor can support your Gardner Denver air compressor with these services:

1. Trained parts specialists to assist you in selecting the correct replacement parts.
2. Factory warranted new and remanufactured rotary screw airends. Most popular model remanufactured airends are maintained in stock at the Remanufacturing Center for purchase on an exchange basis with liberal core credit available for the replacement unit.
3. A full line of factory tested AEON™ compressor lubricants specifically formulated for use in Gardner Denver compressors.
4. Repair and maintenance kits designed with the necessary parts to simplify servicing your compressor.

Authorized distributor service technicians are factory trained and skilled in compressor maintenance and repair. They are ready to respond and assist you by providing fast, expert maintenance and repair services.

To Contact Gardner Denver or locate your local distributor:

visit: www.contactgd.com/compressors

or

call: (217)222-5400

INSTRUCTIONS FOR ORDERING REPAIR PARTS

When ordering parts, specify Compressor MODEL, Method of Cooling, HORSEPOWER and SERIAL NUMBER (see nameplate on unit). The Airend Serial Number is also stamped on top of the discharge bearing carrier casting.

All orders for Parts should be placed with the nearest authorized distributor.

Where NOT specified, quantity of parts required per compressor or unit is one (1); where more than one is required per unit, quantity is indicated in parenthesis. SPECIFY EXACTLY THE NUMBER OF PARTS REQUIRED.

DO NOT ORDER BY SETS OR GROUPS.

To determine the Right-Hand and Left-Hand side of a compressor, stand at the motor end and look toward the compressor. Right-Hand and Left- Hand are indicated in parenthesis following the part name, i.e. (RH) and (LH), when appropriate.

TOTAL PRODUCT SUPPORT – GARDNER DENVER’S CONTINUING COMMITMENT TO YOUR AIR COMPRESSOR PERFORMANCE

Commitment to total product support continues long after the purchase of your quality Gardner Denver rotary screw compressor.

Gardner Denver original parts incorporate years of experience and improvements in design, materials and quality assurance. Maintaining your compressor investment with Gardner Denver parts will insure protection for the air compressor unit and long, dependable service life.

Your authorized Gardner Denver compressor distributor maintains a complete stock of all common maintenance parts, factory approved AEON lubricants, and Gardner Denver factory warranted exchange airends. In addition, authorized distributor technicians are factory trained, and can provide complete diagnostic, compressor maintenance and repair services.

This manual is designed to assist you in maintaining high performance and receiving many years of dependable service you expect from your Gardner Denver compressor.

REMANUFACTURED AIRENDS

Whenever an airend requires replacement or repair, Gardner Denver offers an industry unique, factory remanufactured airend exchange program. From our modern Remanufacturing Center Gardner Denver is committed to supplying you with the highest quality, factory remanufactured airends that are guaranteed to save you time and money.

Immediately Available

Repair downtime costs you money, which is why the most popular models are in inventory at all times.

Skilled Craftsmen

Our Remanufacturing assembly technicians average over 20 years experience with air compression products.

Precision Remanufacturing

All potentially usable parts are thoroughly cleaned, inspected and analyzed. Only those parts that can be brought back to original factory specifications are remanufactured. Every remanufactured airend receives a new overhaul kit: bearings, gears, seals, sleeves and gaskets.

Extensive Testing

Gardner Denver performs testing that repair houses just don't do. Magnaflux and ultrasonic inspection spot cracked or stressed castings, monochromatic light analysis exposes oil leaks, and coordinate measurement machine inspects to +/- .0001", insuring that all remanufactured airends meet factory performance specifications.

Warranty

Gardner Denver backs up every remanufactured airend with a warranty...27 months from purchase.

Gardner Denver remanufactured airends deliver *quality without question...year in and year out.*

Call Gardner Denver for information on the airend exchange program and the name of your authorized distributor.

Phone Number: 217-222-5400 or
Fax: 217-224-7814

TABLE OF CONTENTS

Maintain Compressor Reliability And Performance With Genuine Gardner Denver Compressor Parts And Support Services	1
Instructions For Ordering Repair Parts.....	1
Total Product Support – Gardner Denver’s Continuing Commitment To Your Air Compressor Performance	2
Remanufactured Airends	2
Airend Selection And Repair Kits	4
Bare Compressor - SSQ	5
Discharge Bearing.....	6
Bearing Plate Cover	7
Mounting Group	8
Turn Valve & Part – SSQ	9
Oil Seal Detail – SSQ.....	10
Bare Compressor – SSP.....	11
Turn Valve – SSP.....	12
Oil Seal Detail – SSP	13
Inlet Valve - SSQ.....	14
Inlet Valve – SSP Only	15
Air Filter & Mounting.....	16
Oil Reservoir Group	17
Separator Housing	18
Separator Group	19
Oil Return Line	20
Minimum Pressure/Check Valve – 200 HP	21
Minimum Pressure/Check Valve – 125 & 150 HP	22
Oil Filter & Mixing Valve Assembly.....	23
Cooling Group – Air Cooled – 125 & 150 HP	24, 25
Cooler Group – 200 HP.....	26, 27
Water Cooled Heat Exchanger – With Aftercooler – 200 HP	28, 29
Water Cooled Heat Exchanger – Without Aftercooler – 200 HP	30, 31
Water Cooled Heat Exchanger – With Aftercooler – 125 & 150 HP	32, 33
Water Cooled Heat Exchanger – Without Aftercooler – 125 & 150 HP	34, 35
Control Schematic.....	36, 37
Oil Injection Line.....	38
Turn Valve Actuator (SSQ)	39
Turn Valve Solenoid Valve – SSP.....	40
Compressor Base Group – SSP	41, 42
Enclosure Vent Fan Assembly	43
Enclosure - Basic	44
Enclosure - Hardware	45
Enclosure – Air Cooled Panels.....	46
Enclosure – Water Cooled Panels	47
Enclosure – Basic	48
Air Cooled Baffle	49
Air Cooled Baffle - Hardware.....	50
Enclosure – Water Cooled	51
Main Motor Group	52
Motor List	53
Motor Group (Fan Motors)	54
Miscellaneous Electrical Parts.....	55
Identification And Instruction Group	56, 57
Controller Assembly - Wye Delta Starters.....	58-61
Controller Assembly - 125/150/200 HP Full Voltage	62, 63
Controller Assembly - Less Starter.....	64, 65
Controller Assembly.....	66
Overload Relay Heater Conversion Listing	67
Repair Kits	68-71

For Operating and Service Instructions, see:

SERVICE MANUAL	13-9-666
CONTROLLER MANUAL	13-9-653

AIREND SELECTION AND REPAIR KITS

Model	HP	PSI	Airend w/Inlet Valve	Reman Airend w/Inlet Valve	Bearing Kit *	Gasket Kit	Inlet Valve Kit	TurnValve Kit	Drive Shaft Seal Kit	Drive Shaft Wear Sleeve Removal & Installation Kit
EAQ	125	100	SSQAVAAM01S	SSQAVAAM01X	314SSQ6013	315SSQ6013	301EAQ6013	325SSP6013	200SSQ6007	200SSQ4017
		125	SSQAVAAM04S	SSQAVAAM04X	314SSQ6013	315SSQ6013	301EAQ6013	325SSP6013	200SSQ6007	200SSQ4017
		150	SSPABL01	SSPABG01X	323SSP6013	324SSP6013	301EAQ6013	325SSP6013	300SSP6013	200SSP4017
	150	100	SSQAVAAM02S	SSQAVAAM02X	314SSQ6013	315SSQ6013	301EAQ6013	325SSP6013	200SSQ6007	200SSQ4017
		125	SSQAVAAM01S	SSQAVAAM01X	314SSQ6013	315SSQ6013	301EAQ6013	325SSP6013	200SSQ6007	200SSQ4017
		150	SSQAVAAM04S	SSQAVAAM04X	314SSQ6013	315SSQ6013	301EAQ6013	325SSP6013	200SSQ6007	200SSQ4017
	200	150	SSQAVAAM02S	SSQAVAAM02X	314SSQ6013	315SSQ6013	301EAQ6013	325SSP6013	200SSQ6007	200SSQ4017

* When ordering Bearing Kits, also order Gasket Kit and Drive Shaft Seal Kit.

For listing of Repair Parts included in Kit numbers above, see Repair Kit Section, pages 67-70.

Order by Part Number and Description. Reference Numbers are for your convenience only.

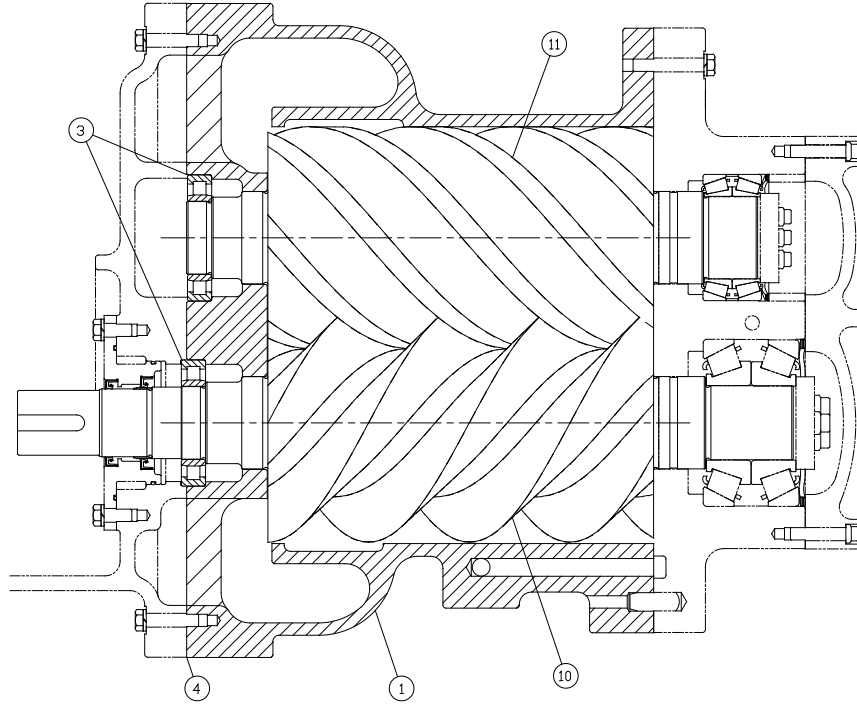

328SSQ810-D
(Ref. Drawing)

BARE COMPRESSOR - SSQ

Ref. No.	Name of Part	Qty.	B/M: 300SSQ4042 307SSQ4028			B/M: 301SSQ4042 308SSQ4028		B/M: 302SSQ4042 309SSQ4028	
			Part No.	Part No.	Part No.	Part No.	Part No.		
1	CYLINDER-AIR	1	304SSQ002	305SSQ002	306SSQ002				
2	SPACER TURN VALVE (not shown).	1	200SSQ392	200SSQ392	----				
* 3	ROLLER BEARING	2	12BA126	12BA126	12BA126				
**4	GASKET ELIMINATOR	1	25BC222	25BC222	25BC222				
5	PLUG (not shown)	3	64AA5	64AA5	64AA5				
6	PLUG (not shown)	3	64AA7	64AA7	64AA7				
7	PLUG (not shown)	1	64B3	64B3	64B3				
8	PLUG (not shown)	1	64B7	64B7	64B7				
9	SPACER (not shown)	1	----	----	200SSQ200				
10	MAIN ROTOR	1	305SSQ010	306SSQ010	307SSQ010				
11	GATE ROTOR	1	308SSQ010	309SSQ010	310SSQ010				

* Parts included in Periodic Overhaul Kit 314SSQ6013. Refer to page 69.

** Parts included in Gasket Kit 315SSQ6013. Refer to page 70.

Order by Part Number and Description. Reference Numbers are for your convenience only.

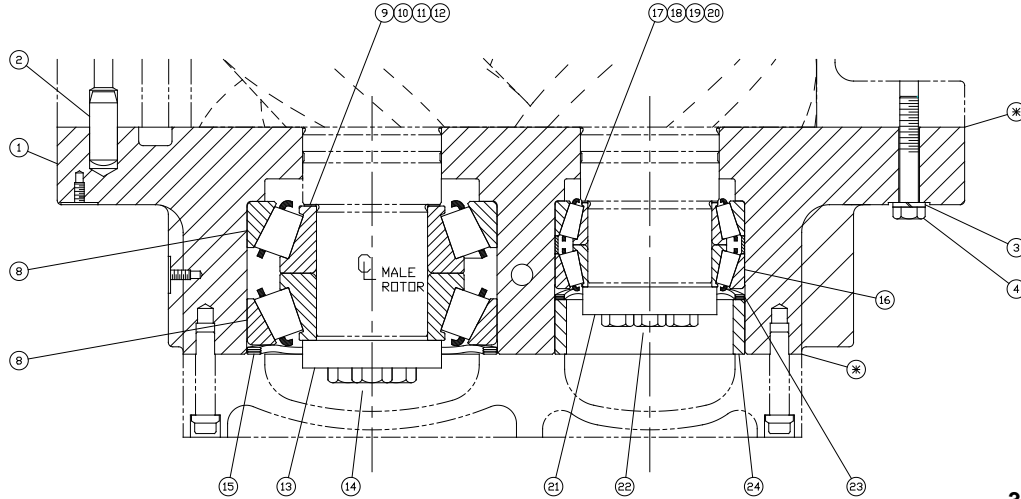

332SSQ810-D
(Ref. Drawing)

(*) DESIGNATES JOINTS REQUIRING GASKET ELIMINATOR - 25BC222

DISCHARGE BEARING

B/M: 308SSQ4044

Ref. No.	Name of Part	Qty.	Part No.
1	HOUSING-BEARING	1	****
2	PIN-DOWEL	1	****
3	LOCKWASHER	25	****
4	SCREW	18	****
5	SCREW	4	****
6	SCREW	3	****
7	SCREW	2	****
** 8	BEARING	1	12BA251
*** 9	SHIM	3	77H107002
***10	SHIM	3	77H107003
***11	SHIM	3	77H107005
***12	SHIM	2	77H107015
13	PLATE-BEARING RETAINER.....	1	****
14	SCREW	3	****
** 15	SPRING.....	1	78W109
** 16	BEARING	1	12BA192
***17	SHIM	3	77H50002
***18	SHIM	3	77H50003
***19	SHIM	3	77H50005
***20	SHIM	3	77H50015
21	PLATE-BEARING RETAINER.....	1	****
22	SCREW	3	****
** 23	SPRING.....	1	78W89
24	SPACER.....	1	****
25	PLUG.....	5	****
26	PLUG.....	1	****
27	PLUG.....	1	****
28	PIN	1	****

** Parts included in Periodic Overhaul Kit 314SSQ6013. Refer to page 69.

*** Parts included in Gasket Kit 315SSQ6013. Refer to page 70.

**** Shown for reference only.

Order by Part Number and Description. Reference Numbers are for your convenience only.

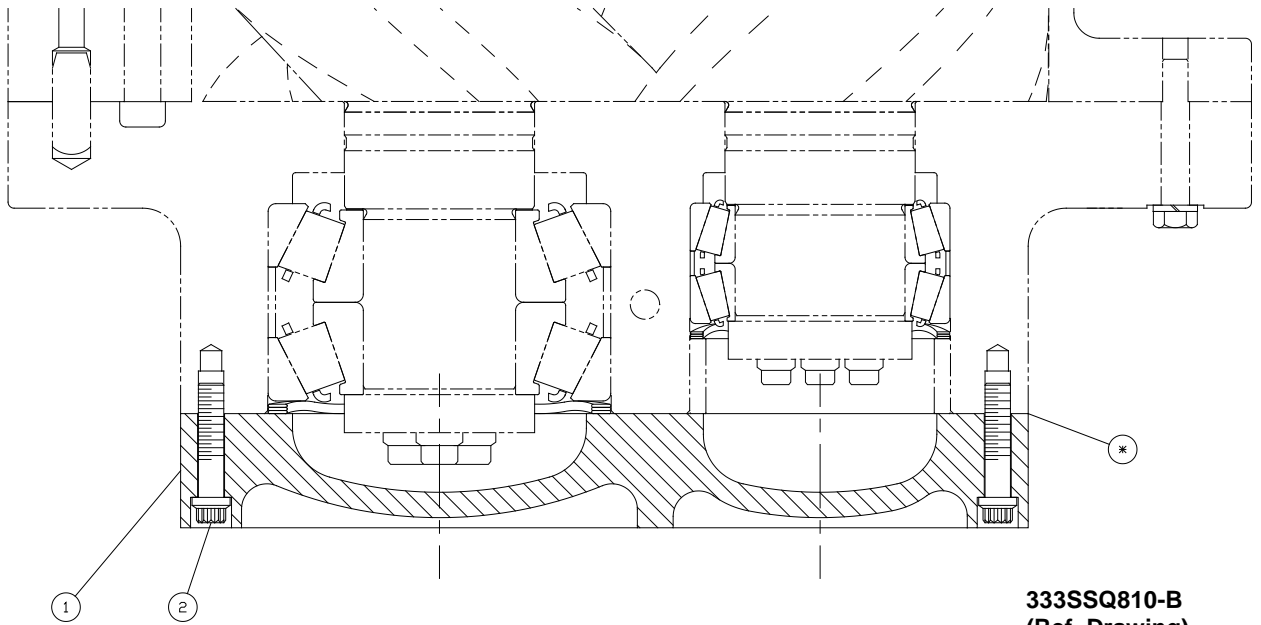

* DESIGNATES JOINTS REQUIRING GASKET ELIMINATOR - 25BC222

333SSQ810-B
(Ref. Drawing)

BEARING PLATE COVER

B/M: 300SSQ4037

Ref. No.	Name of Part	Qty.	Part No.
1	PLATE-BEARING COVER	1	**
2	SCREW-CAP	22	75P78

** Shown for reference only.

Order by Part Number and Description. Reference Numbers are for your convenience only.

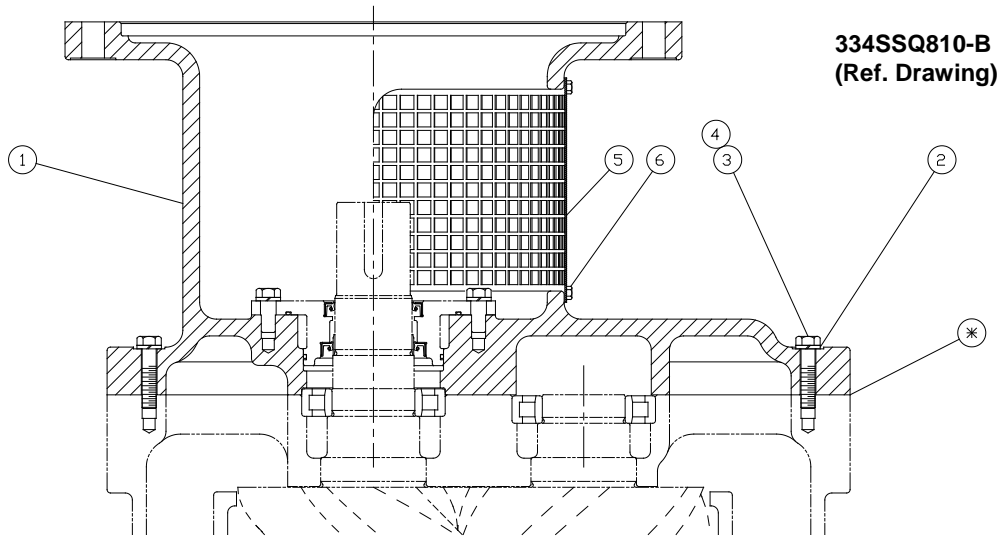

(*) DESIGNATES JOINTS REQUIRING GASKET ELIMINATOR - 25BC222

MOUNTING GROUP

B/M: 300SSQ4017

Ref. No.	Name of Part	Qty.	Part No.
1	ADAPTOR	1	**
2	LOCKWASHER.....	22	95B5
3	SCREW	21	655EE100
4	SCREW	1	655EE140
5	GUARD-COUPLING	1	200SSQ339
6	SCREW	4	75LM150

** Shown for reference only.

Order by Part Number and Description. Reference Numbers are for your convenience only.

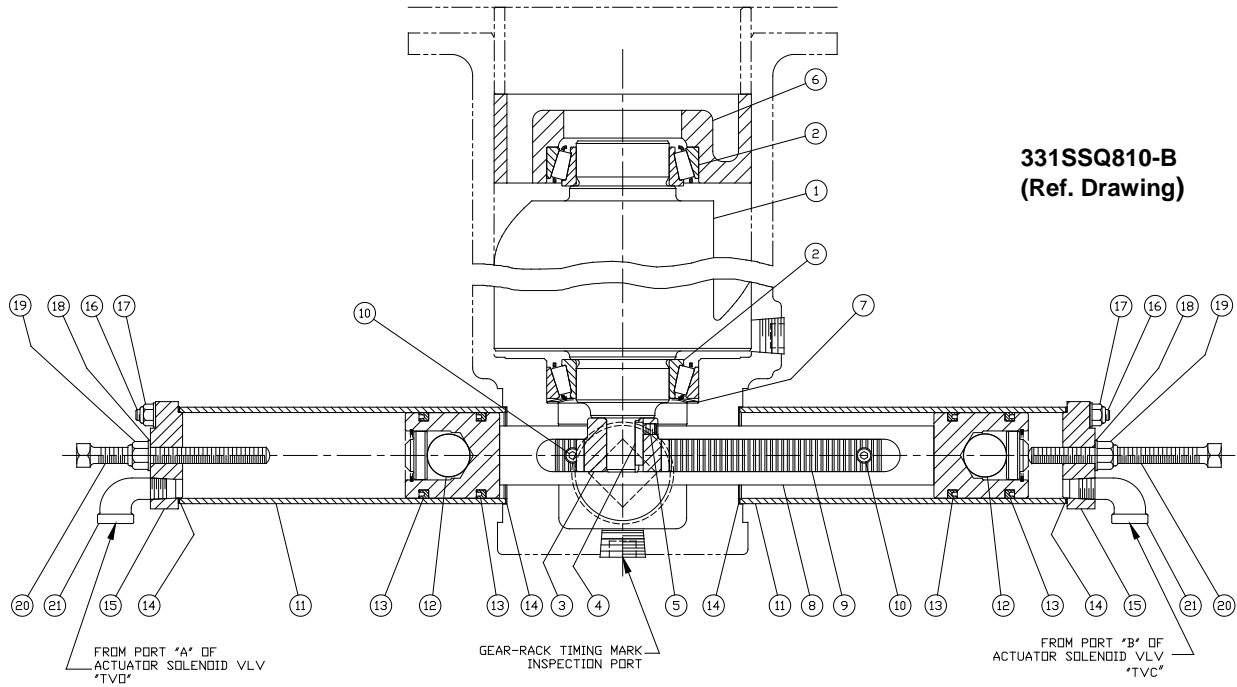

TURN VALVE & PART – SSQ

B/M: 300SSQ4052

Ref. No.	Name of Part	Qty.	Part No.
1	VALVE.....	1	301SSQ238
* 2	ROLLER BEARING.....	2	12BA51
3	GEAR-AUXILLARY.....	1	200SSU031
* 4	KEY.....	1	35C114
5	SCREW.....	1	76G21P
6	HOUSING-BEARING.....	1	215SSQ006
* 7	SPRING.....	1	78W50
8	SHAFT-CONTROL.....	1	200SSU081
9	RACK.....	1	200SSU360
10	SCREW.....	2	75P11N
11	CYLINDER-CONTROL.....	2	200SSU082
12	GROUP-PISTON.....	2	300SSU4056
	PISTON CONTROL.....	1	201SSU084
	* BUMPER.....	1	32E15
	* PLATE-RETAINER.....	1	300SSU168
	* RETAINING RING.....	1	74D49
* 13	PACKING-RING.....	4	60AM46
* 14	GASKET.....	4	25BC138N
15	HEAD-CONTROL CYLINDER.....	2	302SSY083
16	STUD.....	8	79AL5
17	NUT.....	8	50AW24
* 18	SEAL.....	2	60DD801
19	LOCKNUT.....	2	50AW38
20	SCREW.....	2	76D49
21	ELBOW.....	2	64D2G

* Parts included in Periodic Overhaul Kit Part Number 325SSP6013. Refer to page 71.

Order by Part Number and Description. Reference Numbers are for your convenience only.

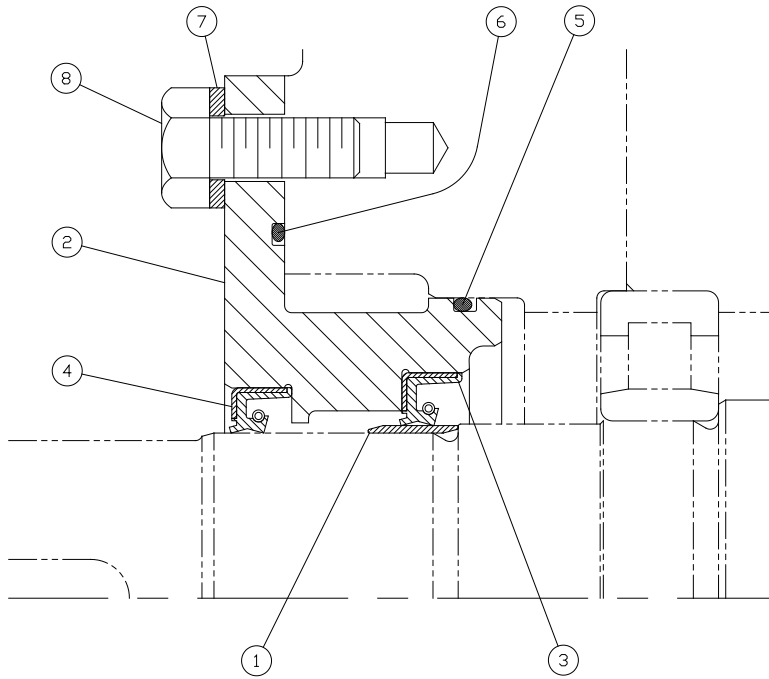

335SSQ810-B
(Ref. Drawing)

OIL SEAL DETAIL – SSQ

B/M: 300SSQ6029

Ref. No.	Name of Part	Qty.	Part No.
* 1	SLEEVE-WEAR.....	1	80M28
2	HOUSING-SEAL	1	207SSQ362
* 3	SEAL-OIL.....	1	60DD571
* 4	SEAL-OIL.....	1	60DD689
* 5	O-RING.....	1	25BC157
* 6	O-RING.....	1	25BC431
7	LOCKWASHER	8	95B5
8	SCREW	8	655EE050
9	PLUG (NOT SHOWN).....	1	64AC1
10	PLUG (NOT SHOWN).....	1	64AC2
* VALVE-CHECK		1	90AR923

* Parts included in Oil Seal Kit Part Number 200SSQ6007. Refer to page 70.

For Wear Sleeve Installation/Removal Kit, order Part Number 200SSQ4017. Refer to page 70.

Order by Part Number and Description. Reference Numbers are for your convenience only.

217SSP810-B
(Ref. Drawing)

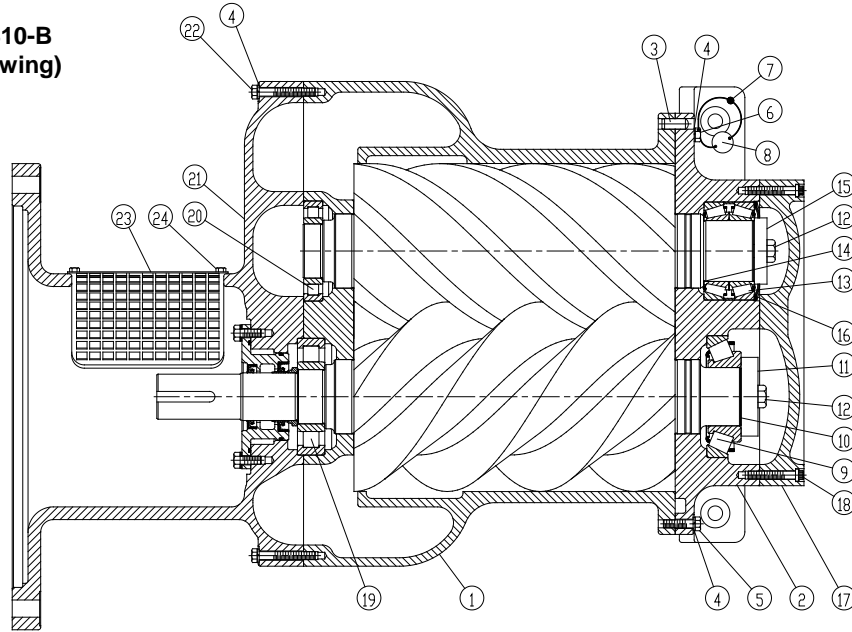

BARE COMPRESSOR – SSP

B/M: 211SSP4000

Ref. No.	Name of Part	Qty.	Part No.
1	CYLINDER	1	***
2	HOUSING-BEARING	1	***
3	PIN-DOWEL	2	***
4	LOCKWASHER	36	***
5	SCREW	14	***
6	SCREW	2	***
7	SEAL-LEAD	1	***
8	TAG-INSTRUCTION	1	***
* 9	ROLLER BEARING	1	12BA105
**10	SHIM SET	1	77H63
11	PLATE-BEARING RETAINER	1	***
12	SCREW	2	***
* 13	ROLLER BEARING	1	12BA198
**14	SHIM SET	1	77H62
15	PLATE-BEARING RETAINER	1	***
* 16	SPRING	1	78W98
17	PLATE-BEARING COVER	1	***
18	SCREW	18	***
* 19	ROLLER BEARING	1	12BA104
* 20	ROLLER BEARING	1	12BA103
21	ADAPTOR	1	***
22	SCREW	19	***
23	GUARD-COUPLING	1	***
24	SCREW	4	***

* Parts included in Bearing Kit Part Number 323SSP6013. Refer to page 69.

** Parts included in Gasket Kit Part Number 324SSP6013. Refer to page 70.

*** Shown for reference only.

Order by Part Number and Description. Reference Numbers are for your convenience only.

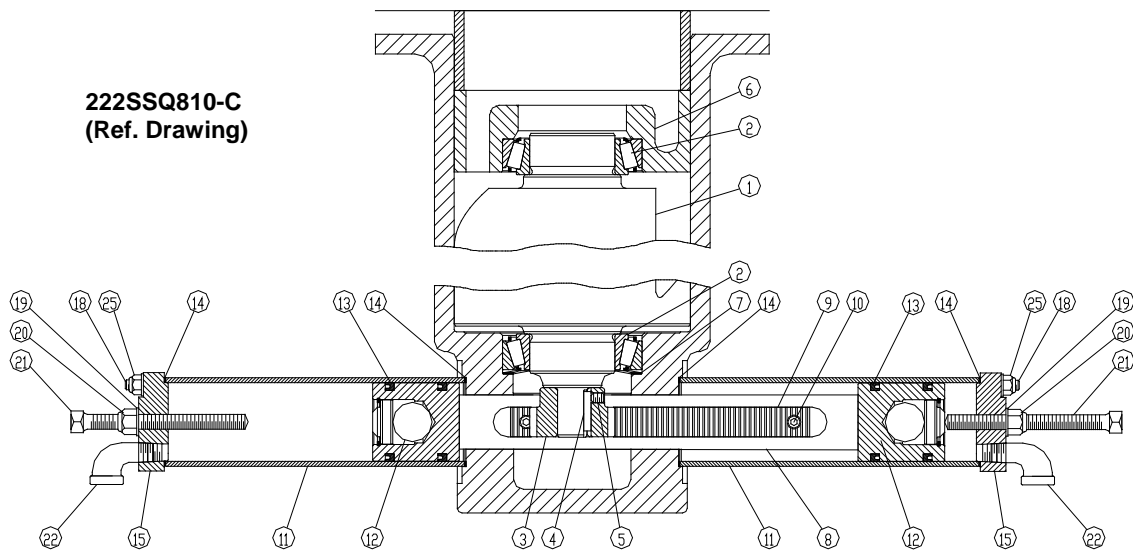

TURN VALVE – SSP

B/M: 200SSQ4049

Ref. No.	Name of Part	Qty.	Part No.
1	VALVE	1	301SSQ238
* 2	ROLLER BEARING	2	12BA51
3	GEAR-AUXILIARY	1	200SSU031
* 4	KEY	1	35C114
5	SCREW	1	76G21P
6	HOUSING-BEARING	1	215SSQ006
* 7	SPRING	1	78W50
8	SHAFT-CONTROL	1	200SSU081
9	RACK	1	200SSU360
10	SCREW	2	75P11N
11	CYLINDER-CONTROL	2	200SSU082
12	PISTON GROUP	2	300SSU4056
	PISTON-CONTROL	1	201SSU084
*	BUMPER	1	32E15
*	PLATE-RETAINER	1	300SSU168
*	RING-RETAINING	1	74D49
* 13	PACKING-RING	4	60AM46
* 14	GASKET	4	25BC138N
15	HEAD-CONTROL CYLINDER	2	302SSY083
18	STUD	8	79AL5
* 19	SEAL	2	60DD801
20	LOCKNUT	2	50AW38
21	SCREW	2	76D49
22	ELBOW	2	64D2G
25	NUT	8	50AW24

* Parts included in Turn Valve Kit Part Number 325SSP6013. Refer to page 71.

Order by Part Number and Description. Reference Numbers are for your convenience only.

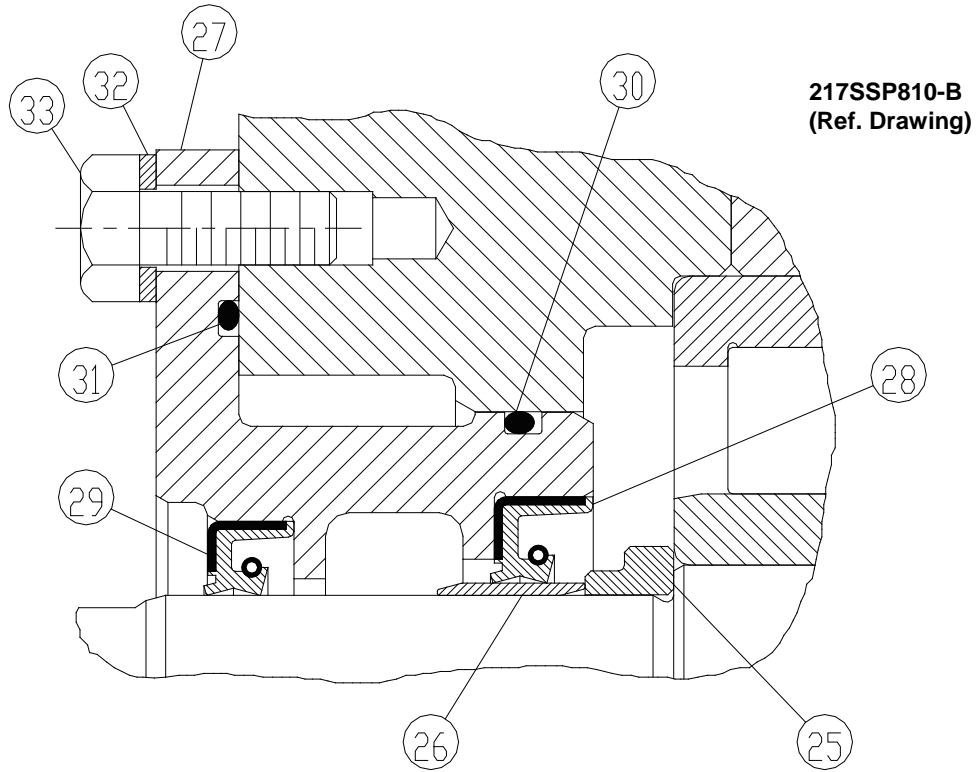

OIL SEAL DETAIL – SSP

B/M: 211SSP4000

Ref. No.	Name of Part	Qty.	Part No.
25	SPACER-SHAFT	1	200SSP600
* 26	SLEEVE-WEAR.....	1	80M40
27	HOUSING-SEAL	1	204SSP362
* 28	SEAL-OIL.....	1	60DD693
* 29	SEAL-OIL.....	1	60DD692
* 30	O-RING.....	1	25BC380
* 31	O-RING.....	1	8502140
32	LOCKWASHER	8	95B5
33	SCREW	8	655EE050
*	VALVE-CHECK (not shown)	1	90AR923

* Parts included in Drive Shaft Seal Kit part Number 300SSP6013. Refer to page 70.

Note: For Wear Sleeve Installation/Removal Kit, see Part Number 200SSP4017. Refer to page 71.

Order by Part Number and Description. Reference Numbers are for your convenience only.

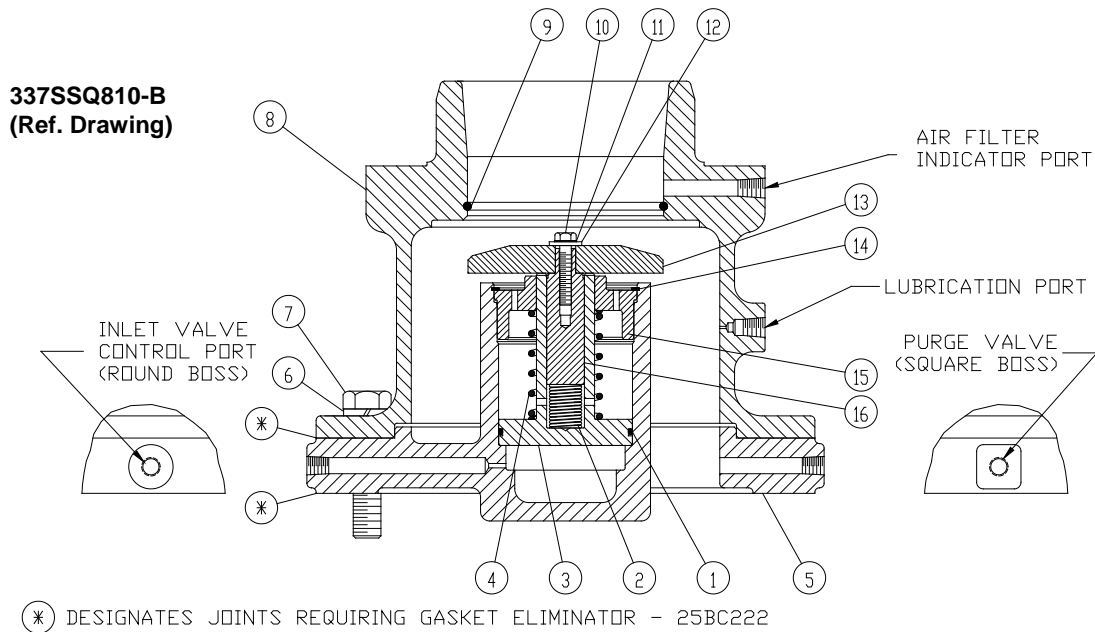

INLET VALVE - SSQ

B/M: 201SSQ4030

Ref. No.	Name of Part	Qty.	Part No.
* 1	O-RING.....	1	25BC298
* 2	SPRING.....	1	78W62
3	PISTON-INLET VALVE.....	1	201SSQ043
* 4	SPRING.....	1	78W61
5	HOUSING-INLET.....	1	204SSQ041
6	LOCKWASHER.....	8	95B8
7	SCREW.....	8	655EG120
8	SEAT.....	1	202SSQ256
* 9	O-RING.....	1	25AM30
10	SCREW.....	1	75A102
11	LOCKWASHER.....	1	95H57
12	WASHER.....	1	95A2
* 13	VALVE-INLET.....	1	201SSQ044
* 14	RING-RETAINING.....	1	74D89
15	RETAINER.....	1	200SSQ205
16	GUIDE-VALVE.....	1	201SSQ483

* Included in Periodic Maintenance Kit 301EAQ6013. Refer to page 69.

Order by Part Number and Description. Reference Numbers are for your convenience only.

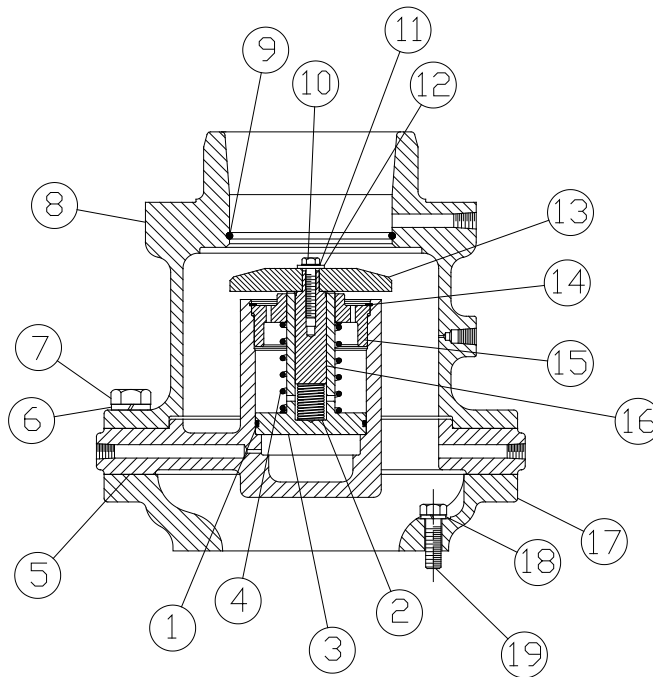

300SSQ810
(Ref. Drawing)

INLET VALVE – SSP ONLY

B/M: 300SSQ4030

Ref. No.	Name of Part	Qty.	Part No.
* 1	O-RING.....	1	25BC298
* 2	SPRING.....	1	78W62
3	PISTON-INLET VALVE.....	1	201SSQ043
* 4	SPRING.....	1	78W61
5	HOUSING-INLET.....	1	204SSQ041
6	LOCKWASHER.....	8	95B8
7	SCREW.....	8	655EG120
8	SEAT.....	1	202SSQ256
* 9	O-RING.....	1	25AM30
10	SCREW.....	1	75A102
11	LOCKWASHER.....	1	95H57
12	WASHER.....	1	95A2
13	VALVE-INLET.....	1	201SSQ044
* 14	RING-RETAINING.....	1	74D89
15	RETAINER.....	1	200SSQ205
16	GUIDE-VALVE.....	1	201SSQ483
17	ADAPTOR.....	1	200SSM170
18	LOCKWASHER.....	8	95B5
19	SCREW.....	8	655EE070

* Included in Periodic Maintenance Kit Part Number 301EAQ6013. Refer to page 69

Order by Part Number and Description. Reference Numbers are for your convenience only.

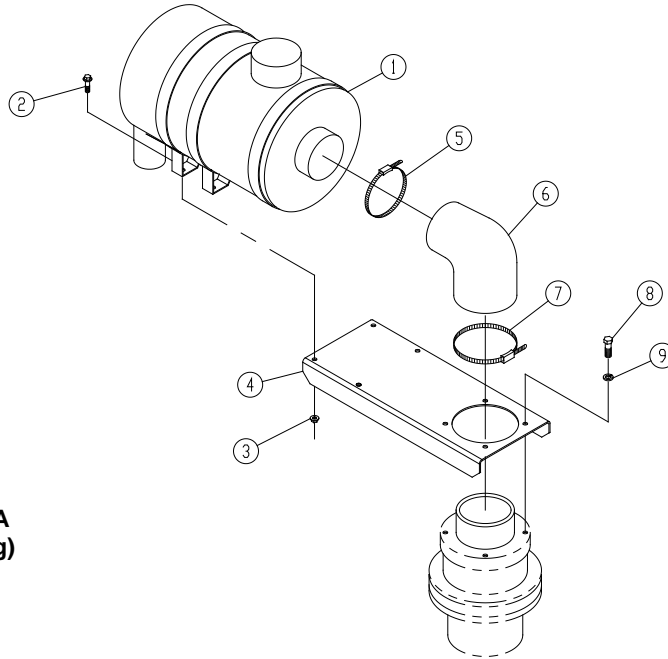

315EAQ810-A
(Ref. Drawing)

AIR FILTER & MOUNTING

B/M: 300EAQ4054

Ref. No.	Name of Part	Qty.	Part No.
1	FILTER-AIR	1	5L353
2	SCREW	4	75LM51
3	NUT	4	50AW5
4	BRACKET-FILTER	1	301EAQ389
5	CLAMP	1	29B46
6	HOSE.....	1	29Z96
7	CLAMP	1	2009499
8	SCREW	4	655EE040
9	LOCKWASHER	4	95B5
*	ELEMENT (AIR FILTER) FOR REPAIR.....	1	2118349

* Not shown.

Order by Part Number and Description. Reference Numbers are for your convenience only.

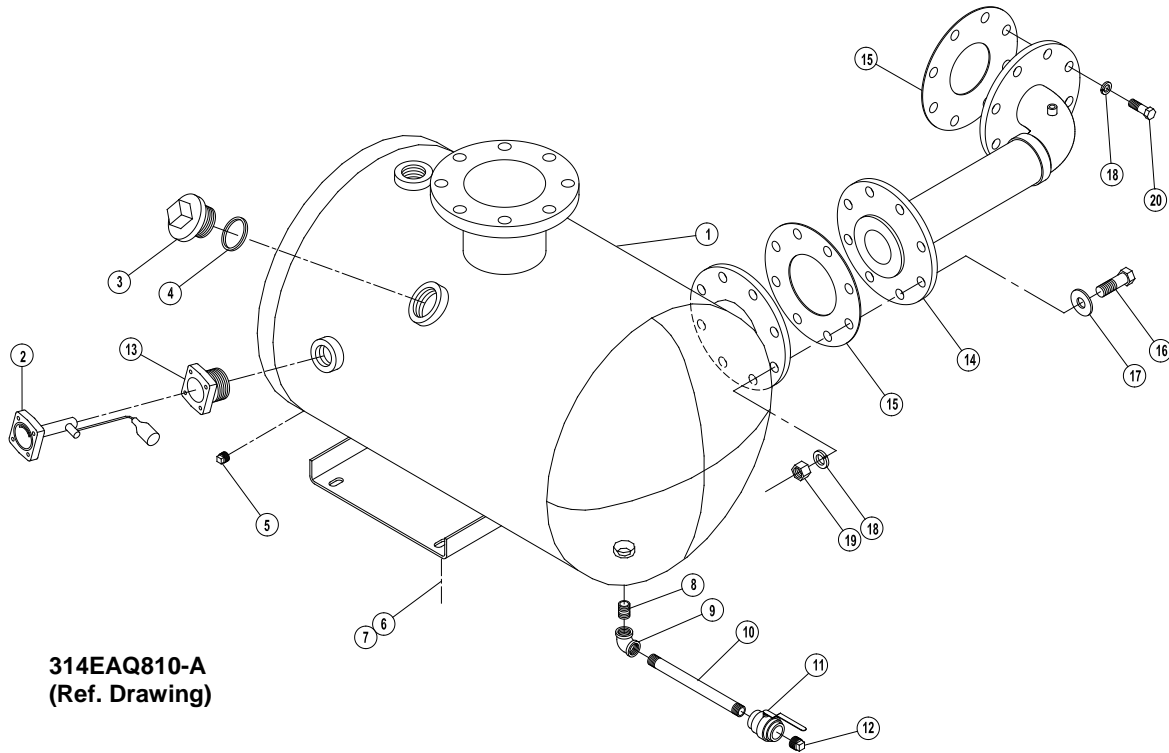

314EAQ810-A
(Ref. Drawing)

OIL RESERVOIR GROUP

B/M: 302EAQ4018

Ref. No.	Name of Part	Qty.	Part No.
* 2	GAUGE-FLOAT	1	300EBM303
3	COVER-FILLER	1	200SPF156
4	O-RING	1	25BC900
5	PLUG	1	64AA5
6	SCREW	4	75LM135
7	NUT	4	50AW35
8	NIPPLE	1	63F1G
9	ELBOW	1	64C4G
10	NIPPLE	1	63F15G
11	VALVE-BALL	1	90AR360
12	PLUG	1	64AA7
13	ADAPTOR-GAUGE	1	200EDE058
14	MANIFOLD-DISCHARGE	1	300EAQ071
15	GASKET	2	25C121N
16	SCREW	8	655EF120
17	WASHER	8	95A7
18	LOCKWASHER	16	95B7
19	NUT	8	50B7
20	SCREW	8	655EF070

* For Repair, order Float Gauge Gasket Part Number 54C204.

Order by Part Number and Description. Reference Numbers are for your convenience only.

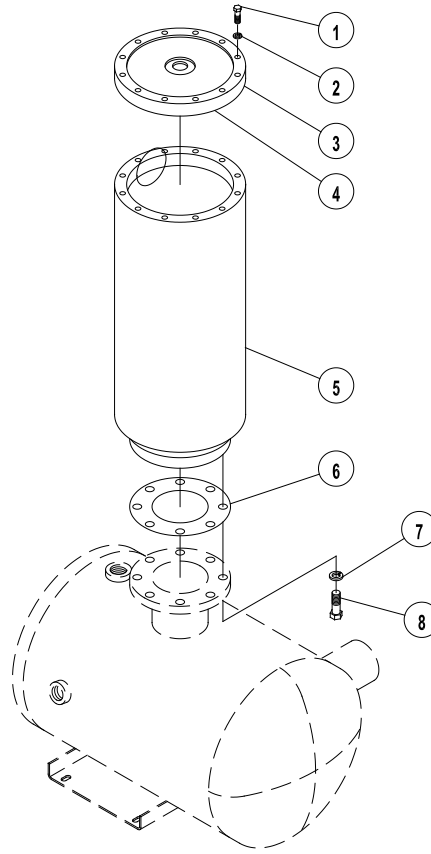

209EDM810-A
(Ref. Drawing)

SEPARATOR HOUSING

B/M: 201EDM4018

Ref. No.	Name of Part	Qty.	Part No.
1	SCREW.....	12	655EE090
2	LOCKWASHER	12	95B5
3	COVER	1	200EDM225
4	GASKET ELIMINATOR	1	25BC222
5	HOUSING	1	200EDM405
6	GASKET	1	25C2719N
7	LOCKWASHER	8	95B8
8	SCREW.....	8	655EG080

Order by Part Number and Description. Reference Numbers are for your convenience only.

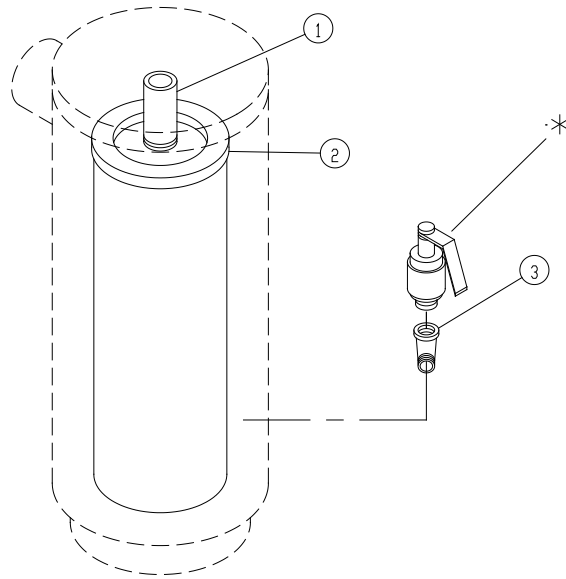

203EDM810-A
(Ref. Drawing)

SEPARATOR GROUP

B/M: 200EDP4013

Ref. No.	Name of Part	Qty.	Part No.
1	SPACER	1	201EDM392
** 2	AIR/OIL SEPARATOR.....	1	VP1040693
3	ELBOW	1	64D8G
*	RELIEF VALVE.....		
	100 PSI		90AR510
	125 PSI		90AR532
	150 PSI		90AR976

** For Separator Repair Kit, order Part Number 305EBQ6013. Refer to page 68.

Order by Part Number and Description. Reference Numbers are for your convenience only.

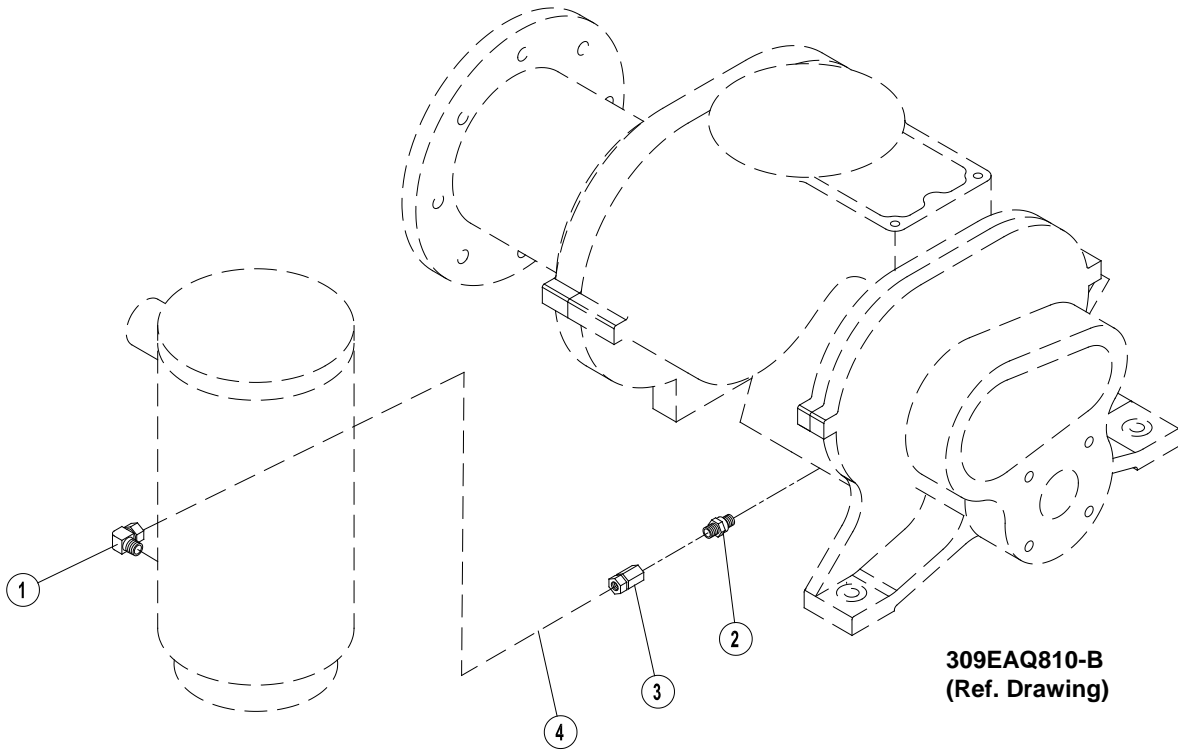

OIL RETURN LINE

B/M: 308EAQ4017

Ref. No.	Name of Part	Qty.	Part No.
1	TUBE FITTING	1	86E220
* 2	VALVE-CHECK	1	90AR261
3	TUBE FITTING	1	86E218
4	TUBE (IN FEET).....	3	85K3

* Part included in Pneumatic Control Kit Part Number 302EAQ6013. Refer to page 68

Order by Part Number and Description. Reference Numbers are for your convenience only.

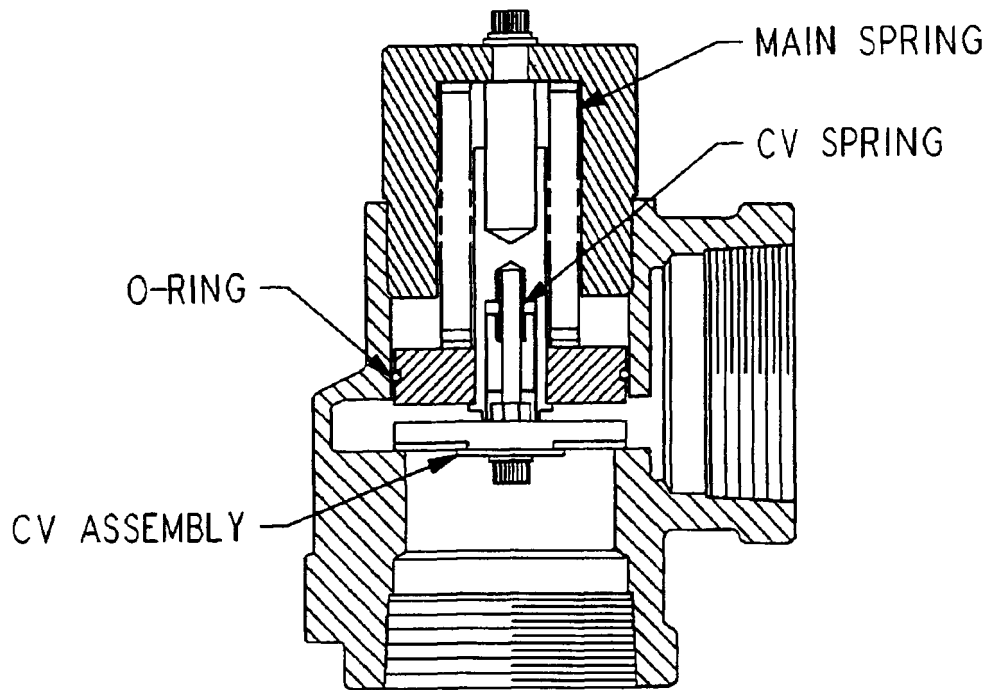

MINIMUM PRESSURE/CHECK VALVE – 200 HP

Name of Part	Qty.	200 HP 3" Part No.
MINIMUM PRESSURE VALVE ASSEMBLY.....	1	201EDM527
REPAIR KIT:.....	1	2116855
CHECK VALVE ASSEMBLY.....	1	
MAIN SPRING.....	1	
CHECK VALVE SPRING.....	1	
O-RING.....	1	

Order by Part Number and Description. Reference Numbers are for your convenience only.

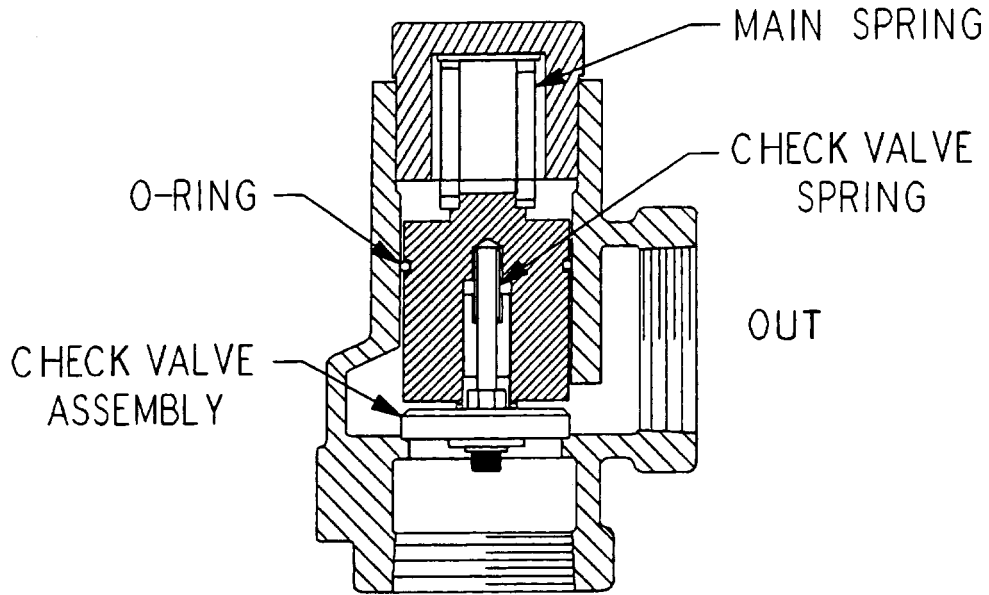

MINIMUM PRESSURE/CHECK VALVE – 125 & 150 HP

Name of Part	Qty.	125 & 150 HP 2" Part No.
MINIMUM PRESSURE VALVE ASSEMBLY	1	301EBM527
REPAIR KIT:	1	2118775
O-RING.....	1	
SPRING, CHECK VALVE	1	
CHECK VALVE ASSEMBLY.....	1	
SPRING, MAIN.....	1	

Order by Part Number and Description. Reference Numbers are for your convenience only.

333EAU810-B
(Ref. Drawing)

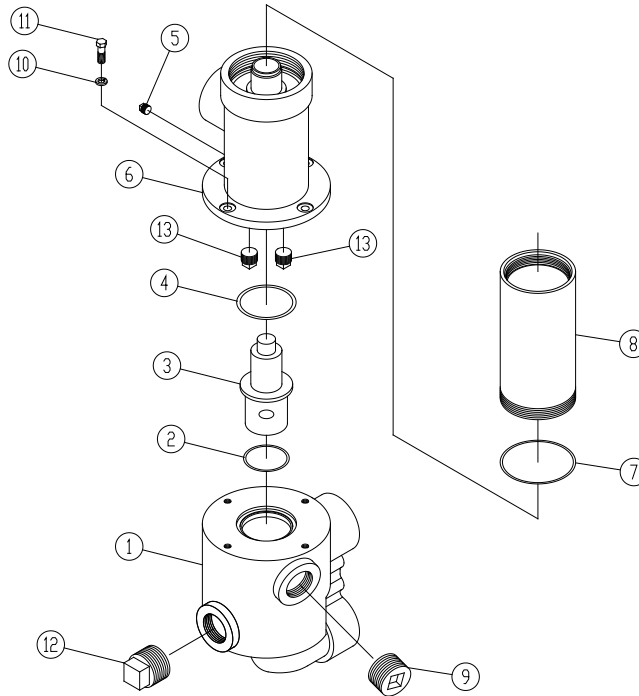

**OIL FILTER & MIXING VALVE ASSEMBLY
(WITH 150°F ELEMENT – STANDARD)**

B/M: 303EAQ2045 (150°F STD.)
304EAQ2045 (180°F)

Ref. No.	Name of Part	Qty.	Part No.
1	MANIFOLD-OIL.....	1	200EAU116
2	O-RING.....	1	25BC127
3	ELEMENT.....	1	
	150°F (Standard)	1	2117382
	140°F (Optional)	1	2117381
	160°F (Optional)	1	2117383
	180°F (Optional)	1	2117384
4	O-RING.....	1	25BC175
5	PLUG	1	64AC2
6	MANIFOLD-OIL.....	1	201EAU116
7	O-RING.....	1	25BC380
* 8	BODY-OIL FILTER	1	200EDM032
9	PLUG	1	64B7
10	LOCKWASHER.....	4	95B3
11	SCREW	4	655ED050
12	PLUG.....	1	64AA2
13	PLUG.....	2	2118347

* For Repair or Filter Element, order Part Number 2118342.

COOLING GROUP – AIR COOLED – 125 & 150 HP

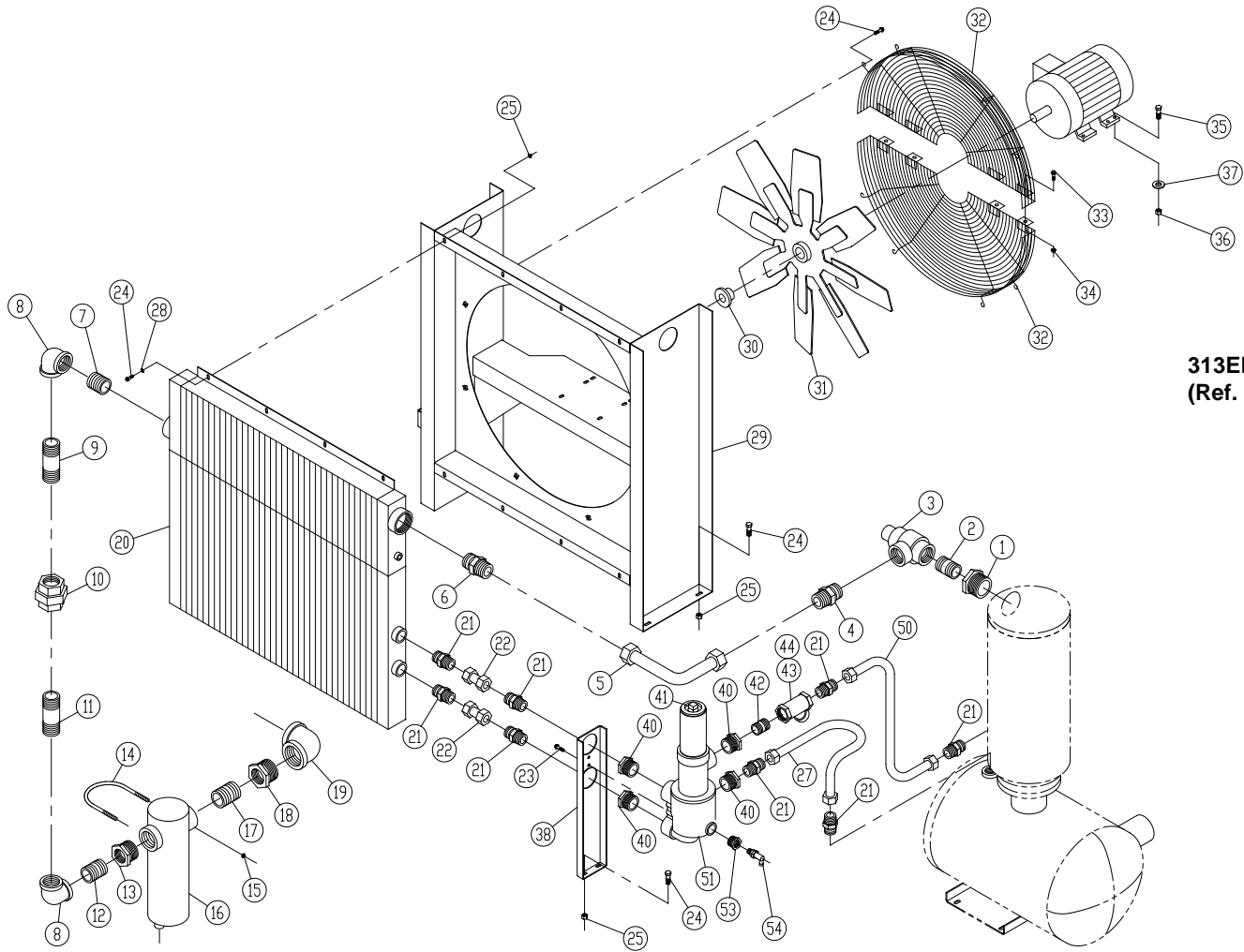

**313EBQ810-B
(Ref. Drawing)**

Order by Part Number and Description. Reference Numbers are for your convenience only.

COOLING GROUP – AIR COOLED – 125 & 150 HP

B/M: 319EBQ4003; 320EBQ4003
 305EAQ4013; 300EDP4013
 308EAQ4013; 309EAQ4013

Ref. No.	Name of Part	Qty.	Part No.	Ref. No.	Name of Part	Qty.	Part No.
1	BUSHING-PIPE	1	64E41	24	SCREW	22	75LM51
2	NIPPLE	1	63L25G	25	NUT	14	50AW5
+ 3	VALVE-MINIMUM PRESSURE.....	1	301EBM527	27	TUBE WITH FITTINGS	1	310EAQ863
4	CONNECTOR TUBE	1	86H142	28	WASHER.....	8	95A3
5	TUBE WITH FITTINGS	1	306EAQ863	29	SUPPORT	1	200EDM165
6	CONNECTOR TUBE	1	86H142	30	BUSHING-HUB	1	22G2
7	NIPPLE	1	63L2G	31	FAN	1	200EAQ701
8	ELBOW	2	64C9G	32	GUARD-FAN	1	200EDM393
9	NIPPLE	1	63L26G	33	SCREW	4	75LM50
10	UNION	1	64Z2	34	NUT	4	50AW4
11	NIPPLE	1	63L26G	35	SCREW	4	75LM78
12	NIPPLE	1	63L16G	36	NUT	4	50AW5
13	BUSHING-PIPE	1	64E25	37	WASHER.....	4	95W15
14	U-BOLT	1	15U75	38	BRACKET (FORMED).....	1	300EAQ142
15	NUT.....	2	50AW35	40	BUSHING-PIPE.....	4	64EB304
* 16	SEPARATOR-MOISTURE	1	83C92	∇ 41	OIL FILTER	1	300EAQ369
17	NIPPLE	1	63M3G	42	NIPPLE-	1	63K20G
18	BUSHING-PIPE	1	64E33	** 43	STRAINER	1	82E49
19	ELBOW	1	64C10G	44	PLUG.....	1	64AA3
20	COOLER-OIL	1	300EAQ201	50	TUBE WITH FITTINGS (SSQ)	1	313EAQ863
	COOLER-OIL (Seacoast).....	1	301EAQ201		TUBE WITH FITTINGS (SSP).....	1	See Page 38
21	CONNECTOR-TUBE	8	86H141	51	FILTER ASSEMBLY (150°) See Page 23 ...	1	303EAQ2045
22	TUBE WITH FITTINGS	2	311EAQ863		FILTER ASSEMBLY (180°) See Page 23 ...	1	304EAQ2045
23	SCREW.....	2	75LM51	53	BUSHING-PIPE.....	1	64E61
				54	OIL SAMPLING VALVE.....	1	86N345

* Repair Parts Kit for Moisture Separator: 2117587 – Valve & Seat Assembly; 2117588 – Cover Gasket; 2117589 – Float & Spindle.

** Repair Parts for Strainer (100 Mesh Screen: 2118378; Blow-Off Bushing: 2118381.

∇ Repair Element Part Number 2118342.

+ For Repair Parts Kits, see page 22.

For Fan Motor Part Numbers, see page 54.

COOLER GROUP – 200 HP

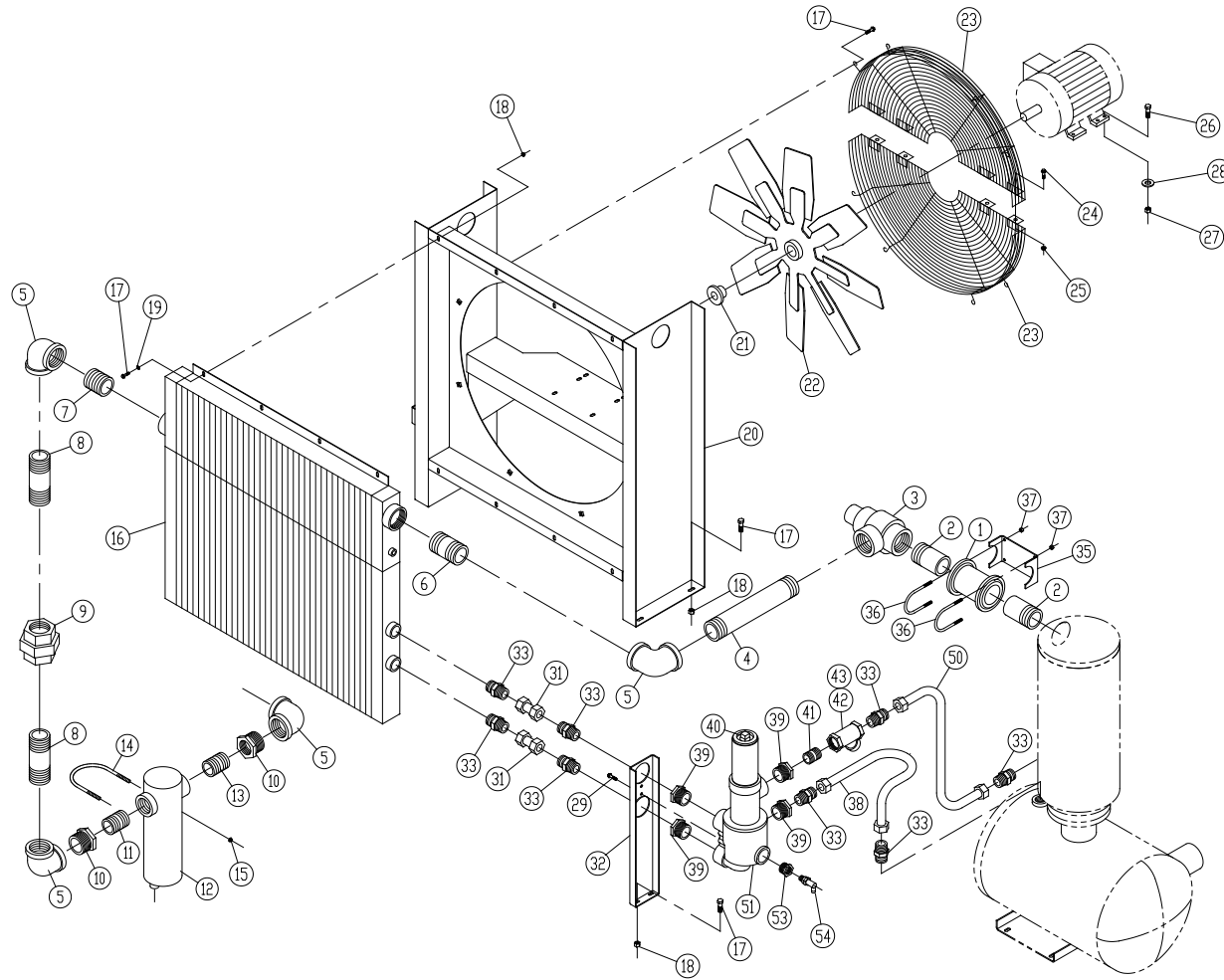

308EBU810-B
(Ref. Drawing)

Order by Part Number and Description. Reference Numbers are for your convenience only.

COOLER GROUP – 200 HP

B/M: 304EBU4003; 305EBU4003
305EAQ4013; 308EAQ4013;
309EAQ4013

Ref. No.	Name of Part	Qty.	Part No.	Ref. No.	Name of Part	Qty.	Part No.
* 1	COUPLING-FLEXIBLE	1	64EB803	23	GUARD-FAN.....	1	200EDM393
2	NIPPLE.....	2	63AJ48X50G	24	SCREW.....	4	75LM50
+ 3	VALVE-MINIMUM PRESSURE ..	1	201EDM527	25	NUT.....	4	50AW4
4	NIPPLE.....	1	63P21G	26	SCREW.....	4	75LM78
5	ELBOW.....	4	64C10G	27	NUT.....	4	50AW5
6	NIPPLE.....	1	63P10G	28	WASHER	4	95W15
7	NIPPLE.....	1	63P1G	29	SCREW.....	2	75LM51
8	NIPPLE.....	2	63P17G	31	TUBE WITH FITTINGS	2	311EAQ863
9	UNION	1	64Z21	32	BRACKET (FORMED)	1	300EAQ142
10	BUSHING-PIPE	2	64E33	33	CONNECTOR-TUBE	8	86H141
11	NIPPLE.....	1	63M3G	35	BRACKET-PIPE.....	1	200EAQ108
**12	SEPARATOR-MOISTURE	1	83C92	36	U-BOLT	2	15U108
13	NIPPLE.....	1	63M3G	37	NUT.....	4	50AW5
14	U-BOLT	1	15U75	38	TUBE WITH FITTINGS	1	310EAQ863
15	NUT	2	50AW35	39	BUSHING-PIPE	4	64EB304
16	COOLER-OIL	1	300EDP201	∇ 40	FILTER – OIL.....	1	300EAQ369
	COOLER-OIL (Seacoast)	1	301EDP201	41	NIPPLE	1	63K20G
17	SCREW	22	75LM51	*** 42	STRAINER.....	1	82E49
18	NUT	14	50AW5	43	PLUG	1	64AA3
19	WASHER.....	8	95A3	50	TUBE WITH FITTINGS (SSQ)	1	313EAQ863
20	SUPPORT	1	200EDM165	51	FILTER ASSEMBLY (150°) See Page 23 ...	1	303EAQ2045
21	BUSHING-HUB	1	22G2		FILTER ASSEMBLY (180°) See Page 23....	1	304EAQ2045
22	FAN	1	200EDP701	53	BUSHING-PIPE	1	64E61
				54	OIL SAMPLING VALVE	1	86N345

* For Repair Order (2) 2117161 Gaskets.

** Repair Parts Kits for Moisture Separator: 2117587 – Valve & Seat Assembly; 2117588 – Cover Gasket; 2117589 – Float & Spindle.

*** Repair Parts for Strainer (100 Mesh Screen): 2118378; Blow-Off Bushing: 2118381.

∇ Repair Element Part Number 2118342.

+ For Repair Parts Kits, see page 21

NOTE: For Fan Motor part numbers, see page 54.

WATER COOLED HEAT EXCHANGER – WITH AFTERCOOLER – 200 HP

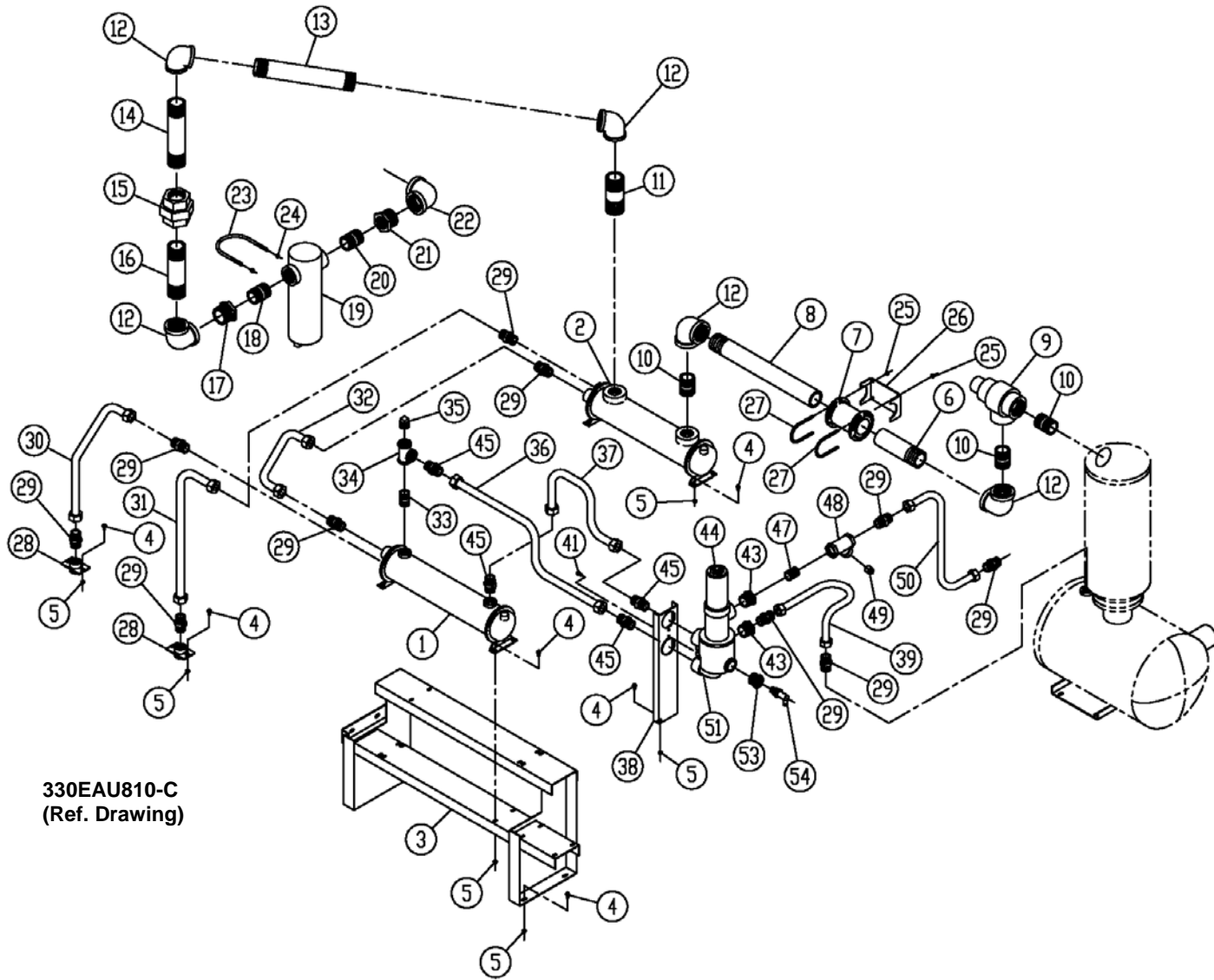

330EAU810-C
(Ref. Drawing)

Order by Part Number and Description. Reference Numbers are for your convenience only.

WATER COOLED HEAT EXCHANGER – WITH AFTERCOOLER – 200 HP

B/M 300EBU4003; 301EBU4003
305EAQ4013; 308EAQ4013;
309EAQ4013

Ref. No.	Name of Part	Qty.	Part No.	Ref. No.	Name of Part	Qty.	Part No.
1	HEAT EXCHANGER (Fresh Water)	1	200EAU349	18	NIPPLE	1	63M3G
	GASKET-RETURN.....	1	2117105	** 19	SEPARATOR-MOISTURE	1	83C92
	GASKET-IN/OUT	1	2117104	20	NIPPLE	1	63M3G
	BONNET-RETURN	1	2117103	21	BUSHING-PIPE.....	1	64E33
	BONNET-IN/OUT	1	2117102	22	ELBOW	1	64C10G
	HEAT EXCHANGER (Salt Water)	1	203EAU349	23	U-BOLT	1	15U75
	BONNET-IN/OUT	1	2117757	24	NUT.....	2	50AW35
	BONNET-RETURN	1	2117758	25	NUT.....	4	50AW5
	GASKET-IN/OUT	1	2117104	26	BRACKET-PIPE	1	200EAQ108
	GASKET-RETURN.....	1	2117105	27	U-BOLT.....	2	15U108
2	AFTERCOOLER (Fresh Water).....	1	204EAU292	28	MANIFOLD-WATER.....	2	200EDM072
	GASKET-RETURN.....	1	2117105	29	CONNECTOR-TUBE.....	10	86H141
	GASKET-IN/OUT	1	2117104	30	TUBE WITH FITTINGS	1	323EAU863
	BONNET-RETURN	1	2117103	31	TUBE WITH FITTINGS	1	321EAU863
	BONNET-IN/OUT	1	2117102	32	TUBE WITH FITTINGS	1	324EAU863
	AFTERCOOLER (Salt Water).....	1	206EAU292	33	NIPPLE	1	63L24G
	BONNET-IN/OUT	1	2117757	34	TEE	1	64G1G
	BONNET-RETURN	1	2117758	**** 35	PLUG	1	64B7
	GASKET-IN/OUT	1	2117104	36	TUBE WITH FITTINGS	1	325EAU863
	GASKET-RETURN.....	1	2117105	37	TUBE WITH FITTINGS	1	326EAU863
3	SUPPORT.....	1	300EAQ165	38	BRACKET (FORMED).....	1	300EAQ142
4	SCREW-FLANGED.....	18	75LM51	39	TUBE WITH FITTINGS	1	310EAQ863
5	NUT	18	50AW5	41	SCREW.....	2	75LM51
6	NIPPLE	1	63AJ48X50G	43	BUSHING-PIPE.....	2	64EB304
* 7	COUPLING-FLEXIBLE.....	1	64EB803	∇ 44	FILTER-OIL	1	300EAQ369
8	NIPPLE	1	63AJ48X234G	45	CONNECTOR-TUBE.....	4	86H142
+ 9	VALVE-MINIMUM PRESSURE	1	201EDM527	47	NIPPLE	1	63K20G
10	NIPPLE	3	63P11G	*** 48	STRAINER	1	82E49
11	NIPPLE	1	63P12G	49	PLUG	1	64AA3
12	ELBOW	5	64C10G	50	TUBE WITH FITTINGS (SSQ).....	1	313EAQ863
13	NIPPLE	1	63N48X200G	51	FILTER ASSEMBLY (150°) See Page 23 ...	1	303EAQ2045
14	NIPPLE	1	63P17G		FILTER ASSEMBLY (180°) See Page 23....	1	304EAQ2045
15	UNION	1	64Z21	53	BUSHING-PIPE.....	1	64E61
16	NIPPLE	1	63P17G	54	OIL SAMPLING VALVE.....	1	86N345
17	BUSHING-PIPE	1	64E33				

* For Repair Order (2) 2117161 Gaskets.

** Repair Parts Kits for Moisture Separator: 2117587 – Valve & Seat Assembly; 2117588 – Cover Gasket; 2117589 – Float & Spindle.

*** Repair Parts for Strainer (100 Mesh Screen): 2118378; Blow-Off bushing: 2118381.

**** NOTE: Remove this plug when Optional Water Temperature Regulator is used. This is where the temperature pick-up goes.

∇ Repair Element Part Number 2118342.

+ For Repair Parts Kits, see page 21

WATER COOLED HEAT EXCHANGER – WITHOUT AFTERCOOLER – 200 HP

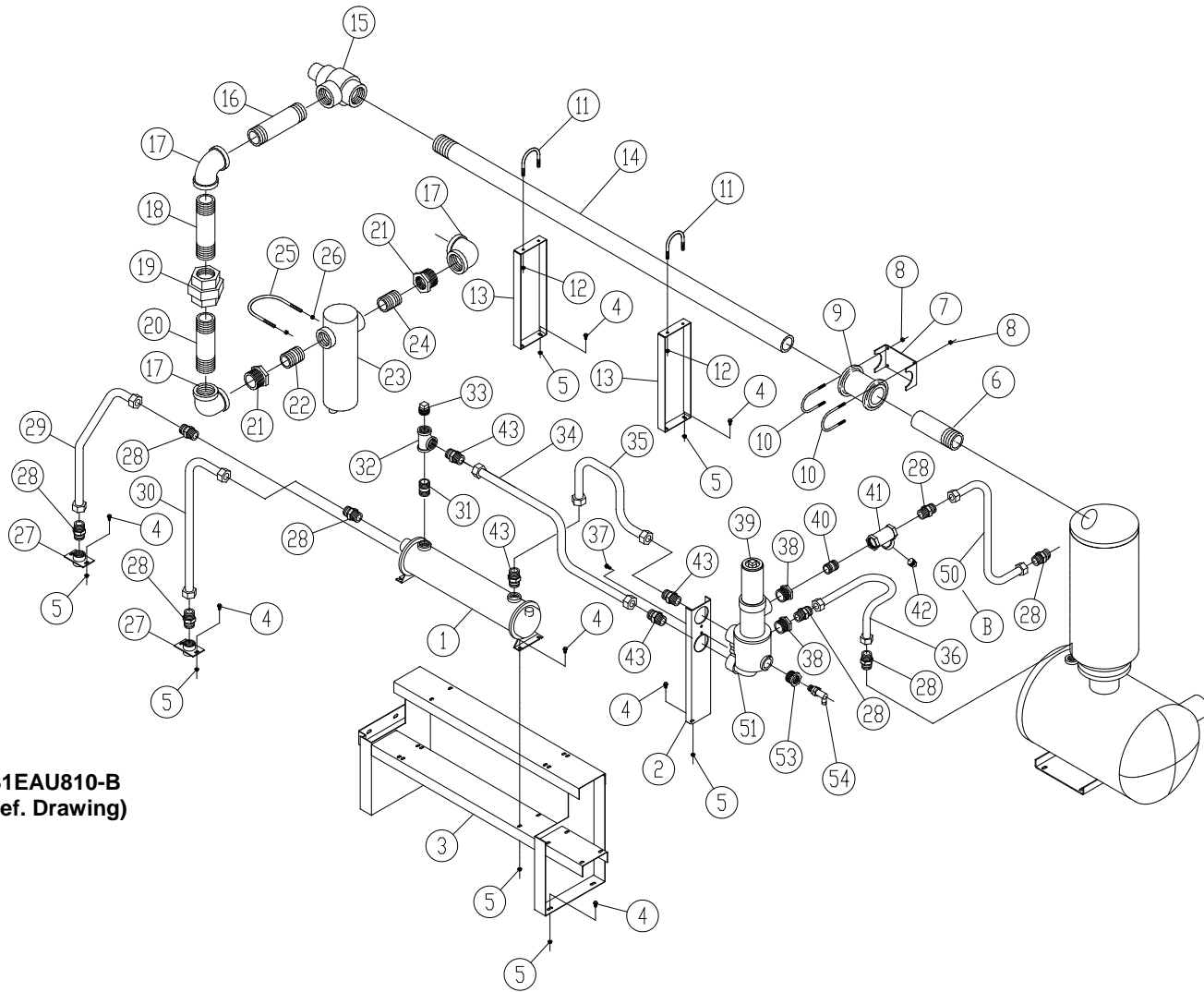

331EAU810-B
(Ref. Drawing)

Order by Part Number and Description. Reference Numbers are for your convenience only.

WATER COOLED HEAT EXCHANGER – WITHOUT AFTERCOOLER – 200 HP

B/M: 302EBU4003; 303EBU4003
305EAQ4013; 308EAQ4013;
309EAQ4013

Ref. No.	Name of Part	Qty.	Part No.	Ref. No.	Name of Part	Qty.	Part No.
1	HEAT EXCHANGER (Fresh Water).....	1	200EAU349	20	NIPPLE.....	1	63P20G
	GASKET-RETURN	1	2117105	21	BUSHING-PIPE	2	64E33
	GASKET-IN/OUT	1	2117104	22	NIPPLE.....	1	63M2G
	BONNET-RETURN	1	2117103	** 23	SEPARATOR-MOISTURE	1	83C92
	BONNET-IN/OUT.....	1	2117102	24	NIPPLE.....	1	63M3G
	HEAT EXCHANGER (Salt Water).....	1	203EAU349	25	U-BOLT	1	15U75
	BONNET-IN/OUT.....	1	2117757	26	NUT	2	50AW35
	BONNET-RETURN	1	2117758	27	MANIFOLD-WATER	2	200EDM072
	GASKET-IN/OUT	1	2117104	28	CONNECTOR-TUBE	8	86H141
	GASKET-RETURN	1	2117105	29	TUBE WITH FITTINGS.....	1	323EAU863
2	BRACKET (FORMED).....	1	300EAQ142	30	TUBE WITH FITTINGS.....	1	322EAU863
3	SUPPORT.....	1	300EAQ165	31	NIPPLE.....	1	63L24G
4	SCREW-FLANGED.....	18	75LM51	32	TEE	1	64G1G
5	NUT.....	18	50AW5	**** 33	PLUG.....	1	64B7
6	NIPPLE	1	63AJ48X50G	34	TUBE WITH FITTINGS.....	1	325EAU863
7	BRACKET-PIPE	1	200EAQ108	35	TUBE WITH FITTINGS.....	1	326EAU863
8	NUT.....	4	50AW5	36	TUBE WITH FITTINGS.....	1	310EAQ863
* 9	COUPLING-FLEXIBLE.....	1	64EB803	37	SCREW	2	75LM51
10	U-BOLT	2	15U108	38	BUSHING-PIPE	4	64EB304
11	U-BOLT	2	15U87	▽ 39	FILTER-OIL	1	300EAQ369
12	NUT.....	4	50AW35	40	NIPPLE.....	1	63K20G
13	BRACKET-PIPE	2	200EDM108	*** 41	STRAINER.....	1	82E49
14	NIPPLE	1	63AJ48X690G	42	PLUG.....	1	64AA3
+15	VALVE-MINIMUM PRESSURE	1	201EDM527	43	CONNECTOR-TUBE	4	86H142
16	NIPPLE	1	63P5G	50	TUBE WITH FITTINGS (SSQ).....	1	313EAQ863
17	ELBOW	3	64C10G	51	FILTER ASSEMBLY (150°) See Page 23	1	303EAQ2045
18	NIPPLE	1	63P25G		FILTER ASSEMBLY (180°) See Page 23	1	304EAQ2045
19	UNION	1	64Z21	53	BUSHING-PIPE	1	64E61
				54	OIL SAMPLING VALVE	1	86N345

* For Repair Order (2) 2117161 Gaskets.

** Repair Parts Kits for Moisture Separator: 2117587 – Valve & Seat Assembly; 2117588 – Cover Gasket; 2117589 – Float & Spindle.

*** Repair Parts for Strainer (100 Mesh Screen): 2118378; Blow-Off Bushing: 2118381.

**** NOTE: Remove this plug when Optional Water Temperature Regulator is used. This is where the temperature pick-up goes.

▽ Repair Element Part Number 2118342.

+ For Repair Parts Kits, see page 21.

WATER COOLED HEAT EXCHANGER – WITH AFTERCOOLER – 125 & 150 HP

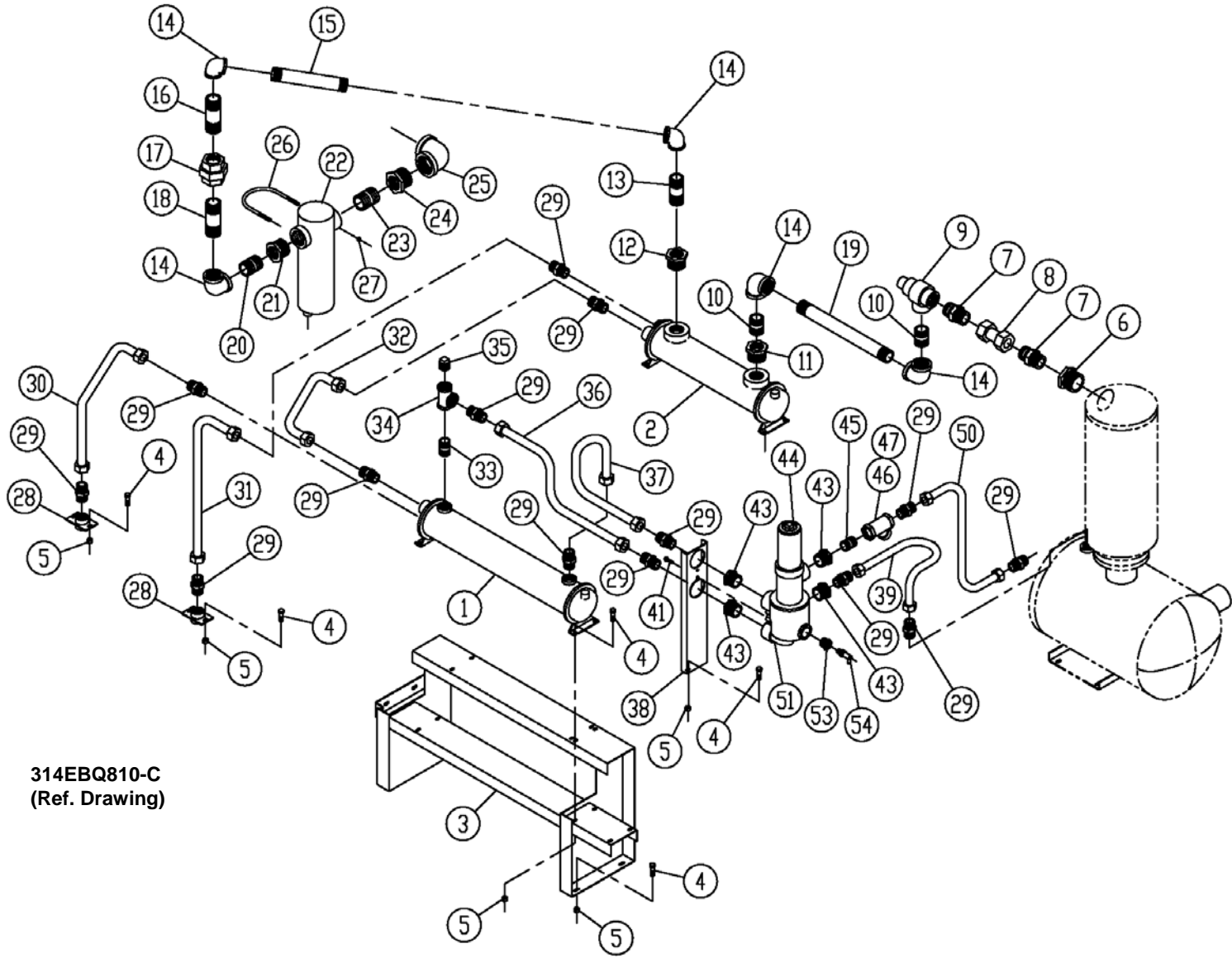

314EBQ810-C
(Ref. Drawing)

**Order by Part Number and Description. Reference Numbers are for your convenience only.
WATER COOLED HEAT EXCHANGER – WITH AFTERCOOLER – 125 & 150 HP**

**B/M: 323EBQ4003; 324EBQ4003;
305EAQ4013; 300EDP4013;
308EAQ4013; 309EAQ4013**

Ref. No.	Name of Part	Qty.	Part No.	Ref. No.	Name of Part	Qty.	Part No.	
1	HEAT EXCHANGER.....	1	200EDM349	17	UNION.....	1	64Z2	
	GASKET-RETURN.....	1	2117180	18	NIPPLE.....	1	63L26G	
	GASKET-IN/OUT.....	1	2109064	19	NIPPLE.....	1	63N32X186G	
	BONNET-RETURN.....	1	2117179	20	NIPPLE.....	1	63L17G	
	BONNET-IN/OUT.....	1	2117178	21	BUSHING-PIPE.....	1	64E25	
	HEAT EXCHANGER (Salt Water) (Optional).	1	201EDM349	*	22	SEPARATOR-MOISTURE.....	1	83C92
	GASKET-RETURN.....	1	2117180	23	NIPPLE.....	1	63M3G	
	GASKET-IN/OUT.....	1	2109064	24	BUSHING-PIPE.....	1	64E33	
	BONNET-RETURN.....	1	2117184	25	ELBOW.....	1	64C10G	
	BONNET-IN/OUT.....	1	2117183	26	U-BOLT.....	1	15U75	
2	AFTERCOOLER.....	1	200EDM292	27	NUT.....	2	50AW35	
	GASKET-RETURN.....	1	2109064	28	MANIFOLD-WATER.....	2	200EDM072	
	GASKET-IN/OUT.....	1	2109063	29	CONNECTOR-TUBE.....	14	86H141	
	BONNET-RETURN.....	1	2117182	30	TUBE WITH FITTINGS.....	1	303EAQ863	
	BONNET-IN/OUT.....	1	2109065	31	TUBE WITH FITTINGS.....	1	304EAQ863	
	AFTERCOOLER (Salt Water) (Optional).....	1	201EDM292	32	TUBE WITH FITTINGS.....	1	301EAQ863	
	GASKET-RETURN.....	1	2109064	33	NIPPLE.....	1	63K6G	
	GASKET-IN/OUT.....	1	2109063	34	TEE.....	1	64G11G	
	BONNET-RETURN.....	1	2109076	***	35	PLUG.....	1	64A8
	BONNET-IN/OUT.....	1	2109077	36	TUBE WITH FITTINGS.....	1	308EAQ863	
3	SUPPORT.....	1	300EAQ165	37	TUBE WITH FITTINGS.....	1	309EAQ863	
4	SCREW.....	18	75LM51	38	BRACKET (FORMED).....	1	300EAQ142	
5	NUT.....	18	50AW5	39	TUBE WITH FITTINGS.....	1	310EAQ863	
6	BUSHING-PIPE.....	1	64E41	41	SCREW.....	2	75LM51	
7	CONNECTOR-TUBE.....	2	86H142	43	BUSHING-PIPE.....	4	64EB304	
8	TUBE WITH FITTINGS.....	1	311EAQ863	∇	44	OIL FILTER.....	1	300EAQ369
+ 9	VALVE-MINIMUM PRESSURE.....	1	301EBM527	45	NIPPLE.....	1	63K20G	
10	NIPPLE.....	2	63L20G	**	46	STRAINER.....	1	82E49
11	BUSHING-PIPE.....	1	64E41	47	PLUG.....	1	64AA3	
12	BUSHING-PIPE.....	1	64E41	50	TUBE WITH FITTINGS (SSQ).....	1	313EAQ863	
13	NIPPLE.....	1	63L7G		TUBE WITH FITTINGS (SSP).....	1	See Page 38	
14	ELBOW.....	5	64C9G	51	FILTER ASSEMBLY (150°) See Page 23 .	1	303EAQ2045	
15	NIPPLE.....	1	63N32X216G		FILTER ASSEMBLY (180°) See Page 23 .	1	304EAQ2045	
16	NIPPLE.....	1	63L27G	53	BUSHING-PIPE.....	1	64E61	
				54	OIL SAMPLING VALVE.....	1	86N345	

* Repair Parts Kits for Moisture Separator: 2117587 – Valve & Seat Assembly; 2117588 – Cover Gasket; 2117589 – Float & Spindle.

** Repair Parts for Strainer (100 Mesh Screen): 2118378; Blow-Off Bushing: 2118381.

*** Note: Remove this plug when Optional Water Temperature Regulator is used. This is where the temperature pick-up goes.

∇ Repair Element Part Number 2118342. + For Repair Parts Kits, see page 22

WATER COOLED HEAT EXCHANGER – WITHOUT AFTERCOOLER – 125 & 150 HP

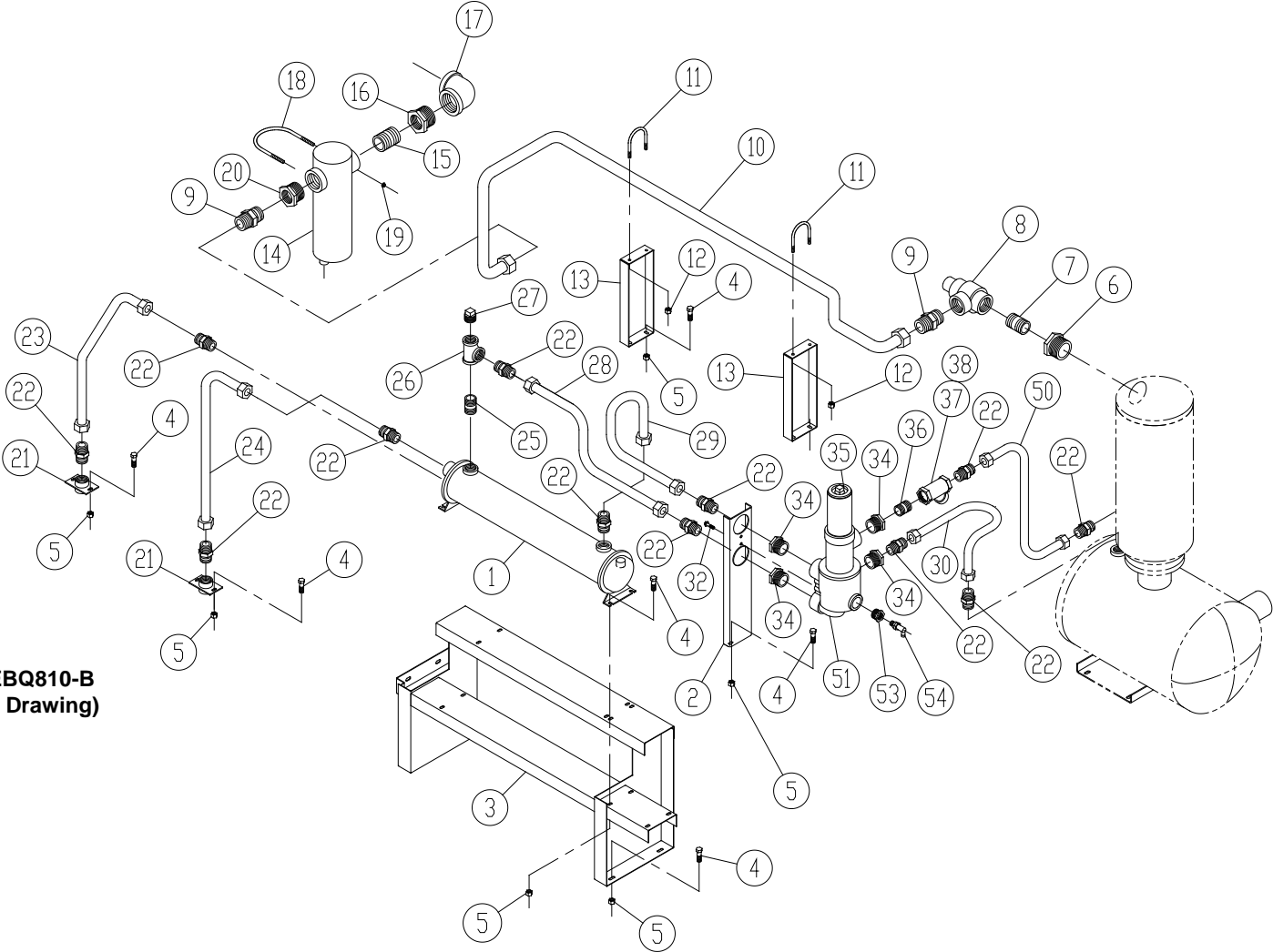

315EBQ810-B
(Ref. Drawing)

Order by Part Number and Description. Reference Numbers are for your convenience only.

WATER COOLED HEAT EXCHANGER – WITHOUT AFTERCOOLER – 125 & 150 HP

B/M: 327EBQ4003; 328EBQ4003
305EAQ4013; 300EDP4013
308EAQ4013; 309EAQ4013

Ref. No.	Name of Part	Qty.	Part No.	Ref. No.	Name of Part	Qty.	Part No.
1	HEAT EXCHANGER	1	200EDM349	17	ELBOW	1	64C10G
	GASKET-RETURN	1	2117180	18	U-BOLT	1	15U75
	GASKET-IN/OUT	1	2109064	19	NUT	2	50AW35
	BONNET-RETURN	1	2117179	20	BUSHING-PIPE	1	64E25
	BONNET-IN/OUT	1	2117178	21	MANIFOLD-WATER	2	200EDM072
	HEAT EXCHANGER (Salt Water) (Optional).	1	201EDM349	22	CONNECTOR-TUBE	12	86H141
	GASKET-RETURN	1	2117180	23	TUBE WITH FITTINGS	1	303EAQ863
	GASKET-IN/OUT	1	2109064	24	TUBE WITH FITTINGS	1	302EAQ863
	BONNET-RETURN	1	2117184	25	NIPPLE	1	63K6G
	BONNET-IN/OUT	1	2117183	26	TEE	1	64G11G
2	BRACKET (FORMED)	1	300EAQ142	*** 27	PLUG	1	64A8
3	SUPPORT	1	300EAQ165	28	TUBE WITH FITTINGS	1	308EAQ863
4	SCREW	18	75LM51	29	TUBE WITH FITTINGS	1	309EAQ863
5	NUT	18	50AW5	30	TUBE WITH FITTINGS	1	310EAQ863
6	BUSHING-PIPE	1	64E41	32	SCREW	2	75LM51
7	NIPPLE	1	63L9G	34	BUSHING-PIPE	4	64EB304
+ 8	VALVE-MINIMUM PRESSURE	1	301EBM527	∇ 35	FILTER – OIL	1	300EAQ369
9	CONNECTOR-TUBE	2	86H142	36	NIPPLE	1	63K20G
10	TUBE WITH FITTINGS	1	305EAQ863	** 37	STRAINER	1	82E49
11	U-BOLT	2	15U18	38	PLUG	1	64AA3
12	NUT	4	50AW5	50	TUBE WITH FITTINGS (SSQ)	1	313EAQ863
13	BRACKET-PIPE	2	300EAQ108		TUBE WITH FITTINGS (SSP)	1	See Page 38
* 14	SEPARATOR-MOISTURE	1	83C92	51	FILTER ASSEMBLY (150°) See Page 23	1	303EAQ2045
15	NIPPLE	1	63M3G		FILTER ASSEMBLY (180°) See Page 23	1	304EAQ2045
16	BUSHING-PIPE	1	64E33	53	BUSHING-PIPE	1	64E61
				54	OIL SAMPLING VALVE	1	86N345

* Repair Parts Kits for Moisture Separator: 2117587 – Valve & Seat Assembly; 2117588 – Cover Gasket; 2117589 – Float & Spindle.

** Repair Parts for Strainer (100 Mesh Screen): 2118378; Blow-Off Bushing: 2118381.

*** Note: Remove this plug when Optional Water Temperature Regulator is used. This is where the temperature pick-up goes.

∇ Repair Element Part Number 2118342.

+ For Repair Parts Kits, see page 22

CONTROL SCHEMATIC

312EAQ810-C
(Ref. Drawing)

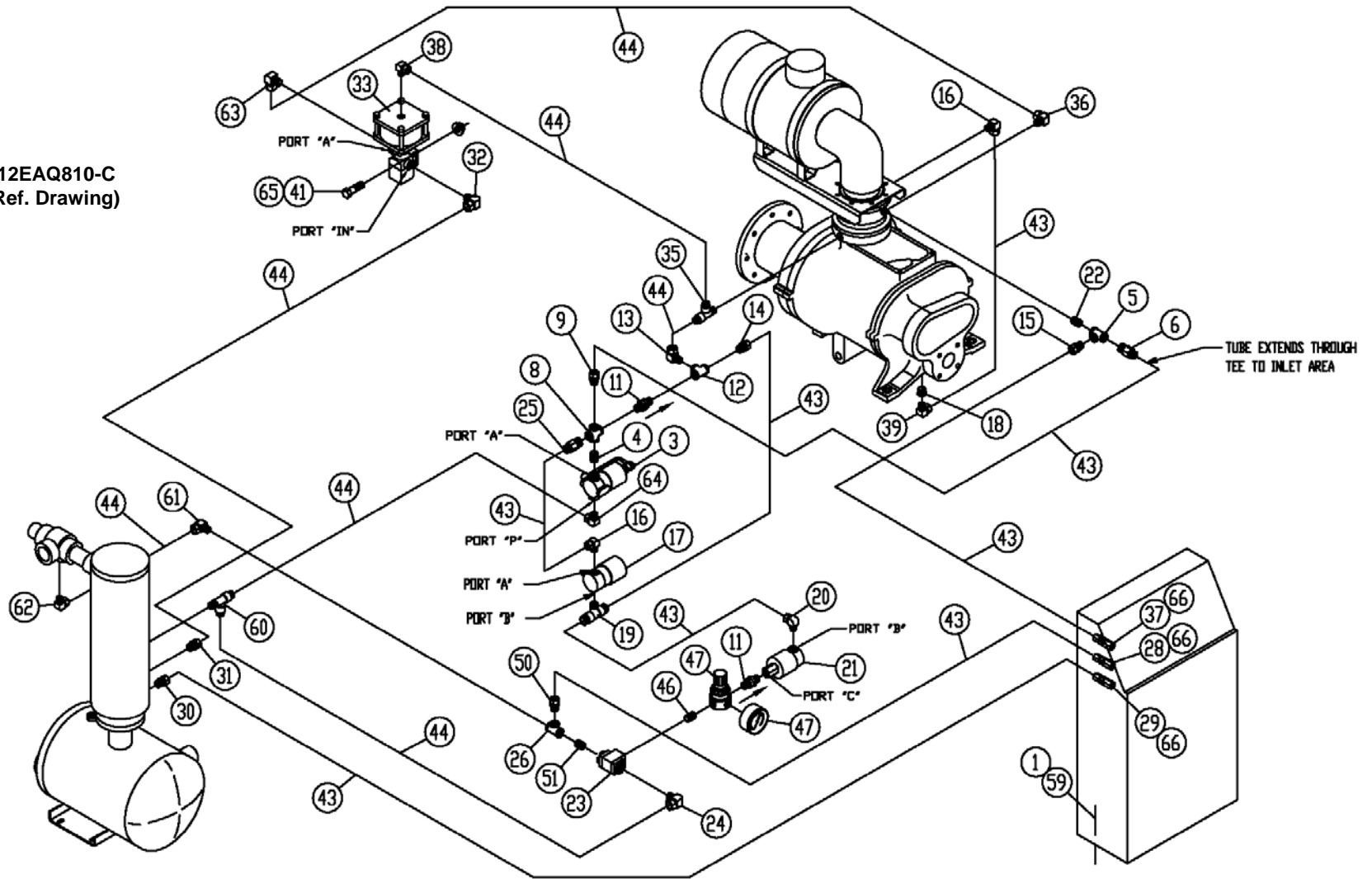

Order by Part Number and Description. Reference Numbers are for your convenience only.

CONTROL SCHEMATIC

B/M: 300EAQ4052
300, 301EBQ4052

Ref. No.	Name of Part	Qty.	Part No.	Ref. No.	Name of Part	Qty.	Part No.
1	SCREW.....	4	75LM51	30	TUBE FITTING	1	86E210
3 *+	VALVE-SOLENOID.....	1	91B250	31	TUBE FITTING	1	86E212
4	NIPPLE	1	63D1G	32	TUBE FITTING	1	86E212
5	TEE	1	64G3G	33 ** ++	CONTROL VALVE	1	90AR1082
6	TUBE FITTING	1	86E242	35	TUBE FITTING	1	86E237
8	CROSS	1	64K1G	36	TUBE FITTING	1	86E222
9	TUBE FITTING	1	86E210	37	CONNECTOR-TUBE	1	86N287
11 ++	VALVE-CHECK.....	2	90AR261	38	TUBE FITTING	1	86E222
12	TEE	1	64G3G	39	TUBE FITTING	1	86E220
13	TUBE FITTING	1	86E222	41	NUT	2	50AW3
14	ORIFICE	1	86N289	43	TUBE (IN FEET)	27	85K3
15	TUBE FITTING	2	86E210	44	TUBE (IN FEET)	31	85K5
16	TUBE FITTING	1	86E220	46	NIPPLE	1	63D1G
17 +	VALVE-SOLENOID.....	1	91B144	47 + +Δ	REGULATOR-PRESSURE W/GAUGE ...	1	88H367
18	BUSHING-PIPE	1	64E2G	50	TUBE FITTING	1	86E210
19	TUBE FITTING	1	86E239	51	NIPPLE	1	63D1G
20	TUBE FITTING	1	86E220	59	NUT	4	50AW5
21 +	VALVE-SOLENOID.....	1	91B143	60	TUBE FITTING	1	86E237
22	NIPPLE	1	63D1G	61	TUBE FITTING	1	86E222
23 ++	VALVE-CONTROL.....	1	90AR1034	62	TUBE FITTING	1	86E222
24	TUBE FITTING	1	86E222	63	TUBE FITTING	1	86E222
25	TUBE FITTING	1	86E210	64	TUBE FITTING	1	86E222
26	TEE	1	64G3G	65	SCREW.....	2	75LM48
28	CONNECTOR-TUBE	1	86N287	66	O-RING.....	3	165011
29	CONNECTOR-TUBE	1	86N287	67	TIE-CABLE (not shown).....	30	24CA127

* For Repair Kit (includes Springs, Seals, Piston Assembly, Plunger Assembly, Nut & O-Ring, order Part Number 2116077 or for Coil, order Part Number 2116078.

+ Parts included in Electrical Control Kit, Part Number 306EAQ6013. Refer to page 68.

** For Repair of U-Cup (Piston Seal), order Part Number 2117904; For O-Ring (Top Plate), order Part Number 2117905.

++ Parts included in Pneumatic Control Kit, Part Number 302EAQ6013. Refer to page 68.

Δ For Replacement Gauge, order Part Number 2118767.

Order by Part Number and Description. Reference Numbers are for your convenience only.

310EAQ810-A
(Ref. Drawing)

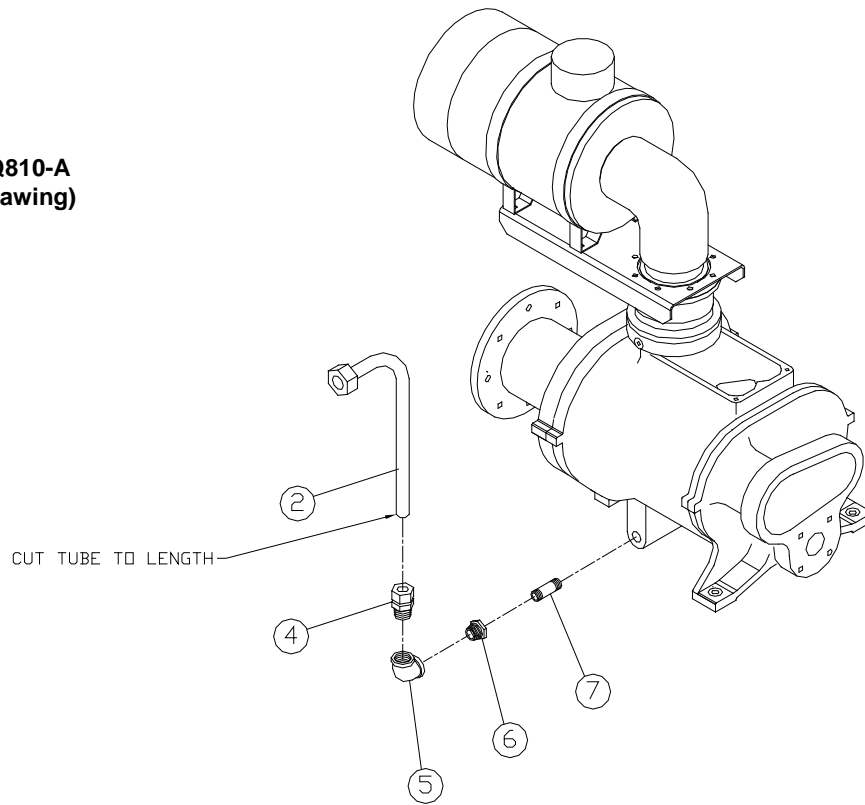

OIL INJECTION LINE

B/M: 313EAQ4017

Ref. No.	Name of Part	Qty.	Part No.
2	TUBE WITH FITTING	1	305EDP863
4	TUBE CONNECTOR	1	86N105
5	ELBOW	1	64C8G
6	PIPE BUSHING	1	64EB303
7	NIPPLE	1	63H11G

Order by Part Number and Description. Reference Numbers are for your convenience only.

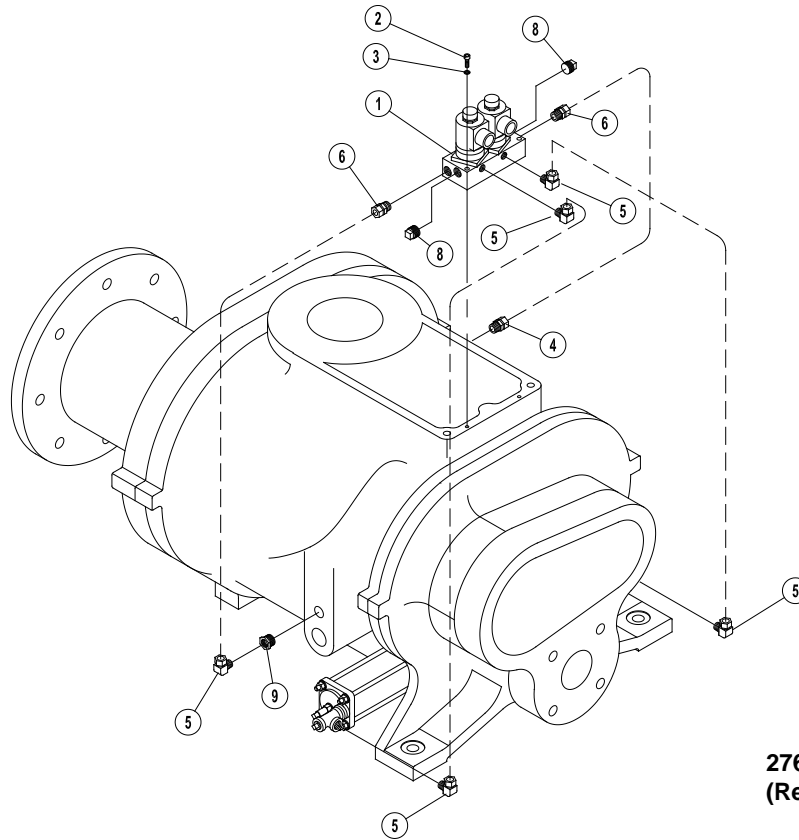

276EAQ810-A
(Ref. Drawing)

TURN VALVE ACTUATOR (SSQ)

B/M: 208EAQ4013

Ref. No.	Name of Part	Qty.	Part No.
** 1	VALVE-SOLENOID	1	301EAQ861
2	SCREW.....	2	75P26
3	LOCKWASHER	2	95B1
4	TUBE FITTING	1	86E210
5	TUBE FITTING	5	86E220
6	TUBE FITTING	2	86E211
* 7	TUBE (IN FEET)	10	85K3
8	PLUG	2	64AC3
9	BUSHING-PIPE	1	64E2G

* Not Shown

** For O-Ring Repair Kit, order Part Number 307EAQ6013. Refer to page 69.

Order by Part Number and Description. Reference Numbers are for your convenience only.

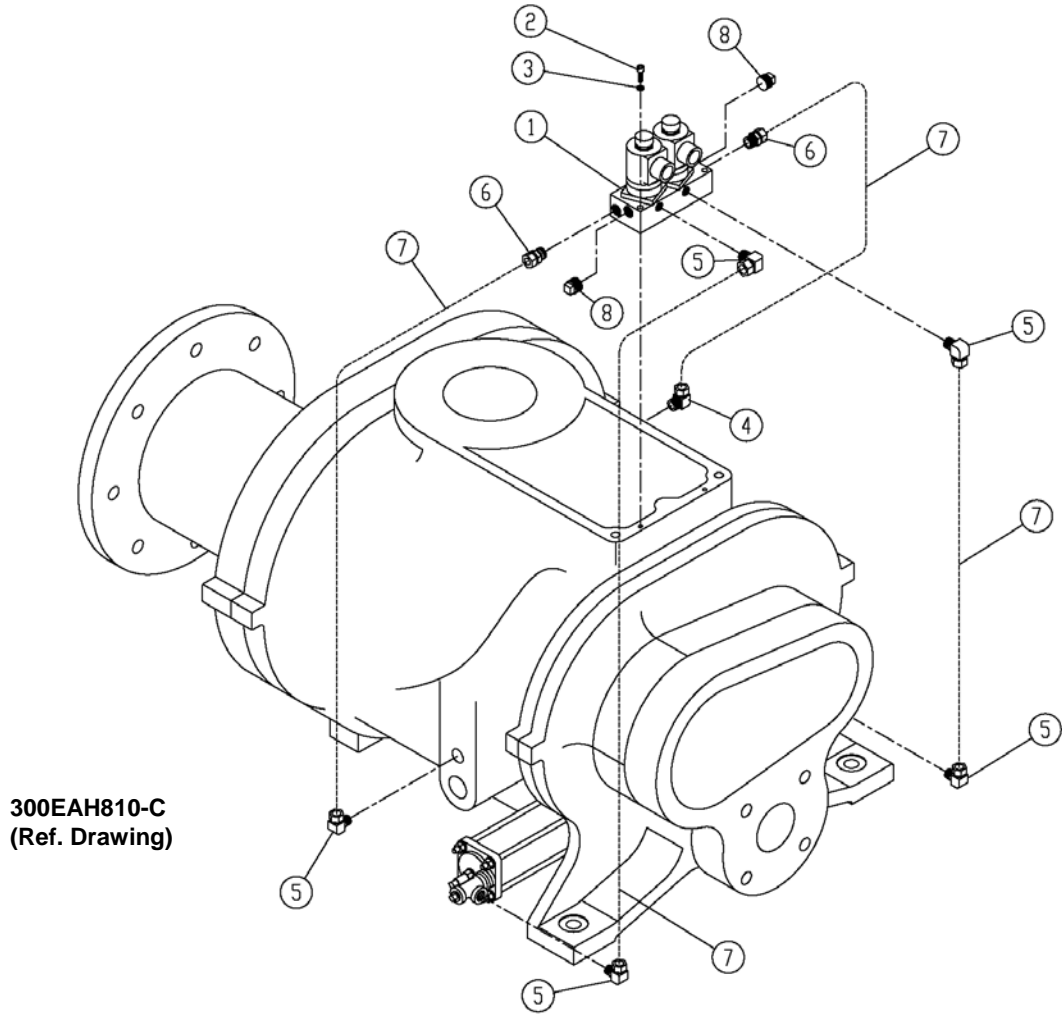

TURN VALVE SOLENOID VALVE – SSP

B/M: EAP81709

Ref. No.	Name of Part	Qty.	Part No.
* 1	VALVE-SOLENOID	1	301EAQ861
2	SCREW	2	75P26
3	LOCKWASHER	2	95B1
4	TUBE FITTING	1	86E220
5	TUBE FITTING	5	86E220
6	TUBE FITTING	2	86E211
7	TUBE BULK (IN FEET)	10	86K3
8	PLUG.....	2	64AC3

* For O-Ring Repair Kit, order Part Number 307EAQ6013. Refer to page 69.

Order by Part Number and Description. Reference Numbers are for your convenience only.

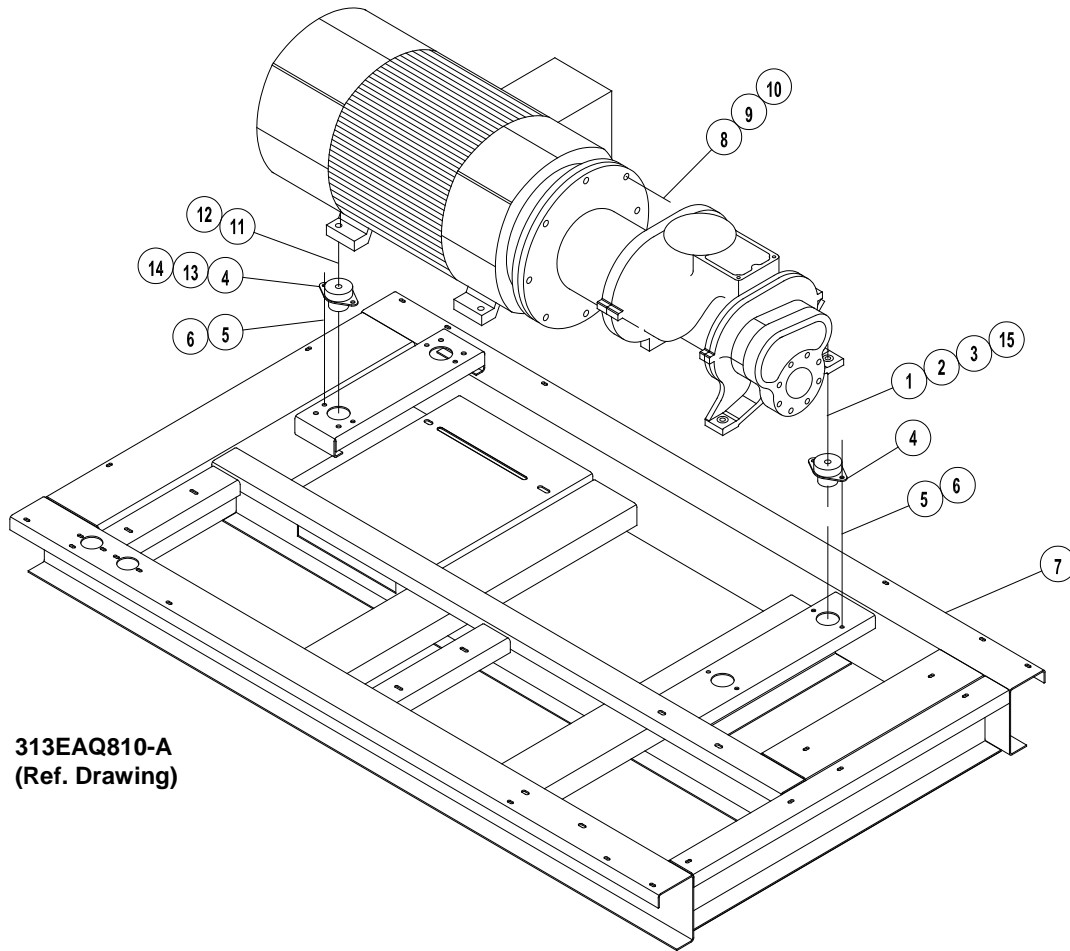

313EAQ810-A
(Ref. Drawing)

COMPRESSOR BASE GROUP – SSP

B/M: 301ERM4017

Ref. No.	Name of Part	Qty.	Part No.
1	SCREW	2	655EF200
2	LOCKWASHER	2	95B7
3	NUT	2	50B7
4	ISOLATOR-VIBRATION.....	4	49C48
5	SCREW	8	75LM135
6	NUT	8	50AW35
7	BASE	1	300ERM285
8	NUT	8	50B8
9	LOCKWASHER	8	95B8
10	SCREW	8	655EG140
11	SCREW	2	655EG240
12	WASHER.....	2	95A8
13	LOCKWASHER	2	95B8
14	NUT	2	50B8
15	WASHER.....	2	95A7
	KEY-SQUARE (not shown)	1	8500082

Order by Part Number and Description. Reference Numbers are for your convenience only.

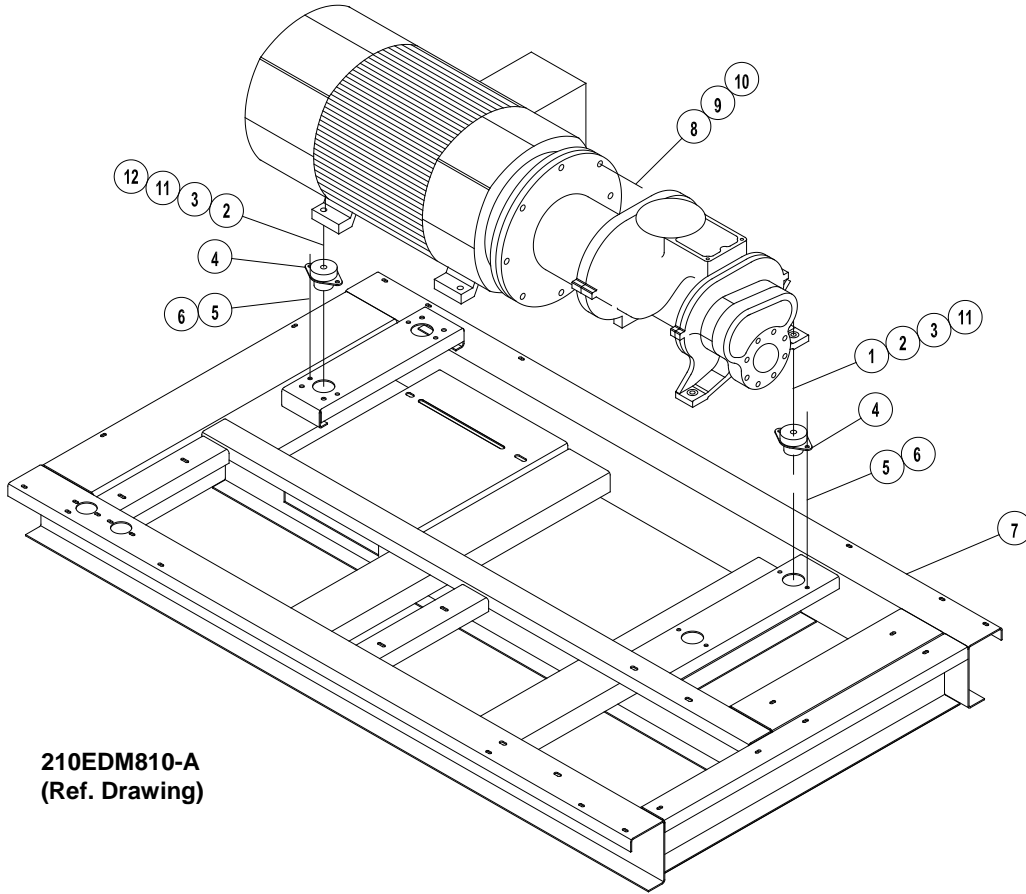

210EDM810-A
(Ref. Drawing)

COMPRESSOR BASE GROUP – SSQ

B/M: 311EAQ4017

Ref. No.	Name of Part	Qty.	Part No.
1	SCREW	2	655EG220
2	LOCKWASHER	4	95B8
3	NUT	4	50B8
4	ISOLATOR-VIBRATION.....	4	49C48
5	SCREW	8	75LM135
6	NUT	8	50AW35
7	BASE	1	300EAQ285
8	NUT	8	50B8
9	LOCKWASHER	8	95B8
10	SCREW	8	655EG140
11	WASHER.....	4	95A8
12	SCREW	2	655EG240
*	KEY-SQUARE	1	35B243

* Not shown on drawing.

Order by Part Number and Description. Reference Numbers are for your convenience only.

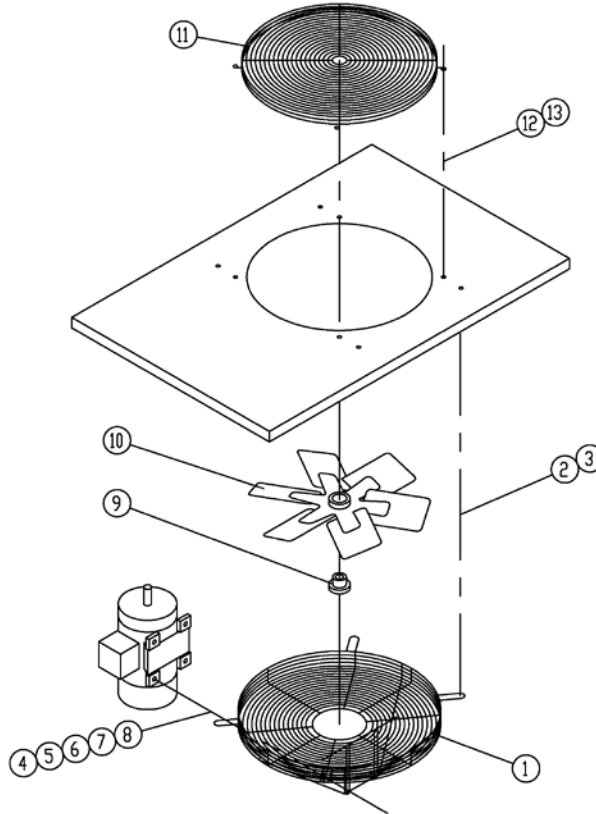

262EAU810-A
(Ref. Drawing)

**ENCLOSURE VENT FAN ASSEMBLY
(WATER COOLED ONLY)**

B/M: 300EBQ4017

Ref. No.	Name of Part	Qty.	Part No.
1	GUARD-FAN	1	202ECM393
2	SCREW	4	75K48
3	WASHER	4	95A5
4	SCREW	4	75A35
5	RETAINER.....	4	2014731
6	WASHER.....	4	95A2
7	LOCKWASHER	4	95B2
8	NUT	4	50B2
9	BUSHING-SHEAVE	1	22G27
10	FAN.....	1	202ECM701
11	GUARD-FAN	1	200ECM393
12	SCREW	4	75LM51
13	NUT	4	50AW5

For Fan Motor part numbers, see Page 54.

Order by Part Number and Description. Reference Numbers are for your convenience only.

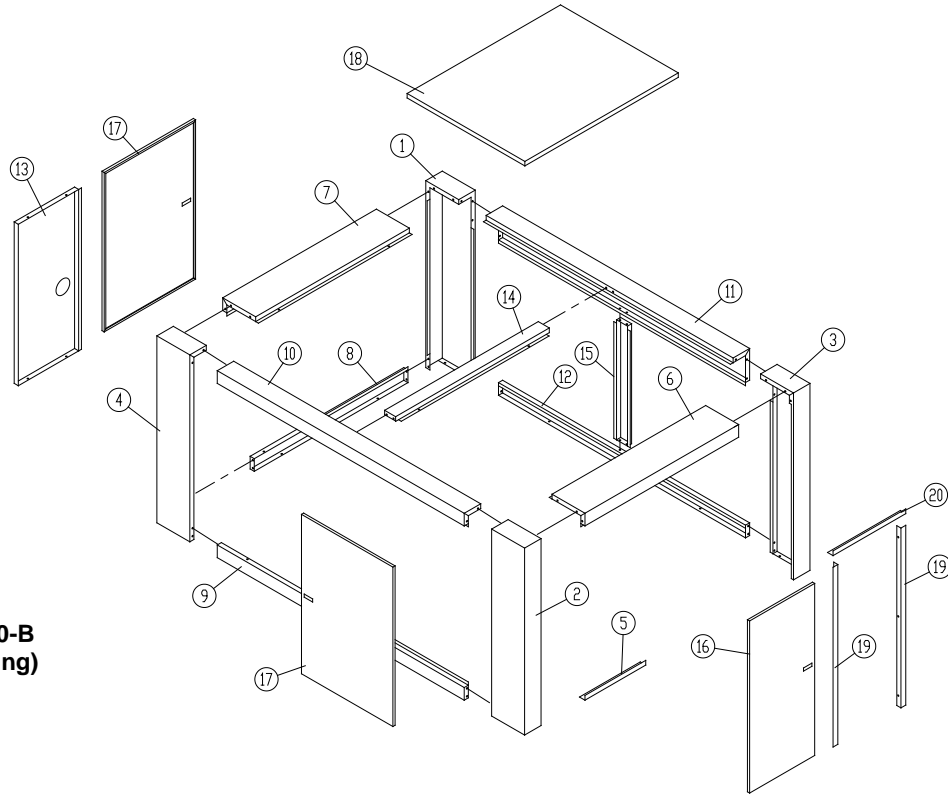

200EDM810-B
(Ref. Drawing)

**ENCLOSURE – BASIC
(STANDARD)**

B/M: 300EBQ4023

Ref. No.	Name of Part	Qty.	Part No.
1	POST	1	CC1046854
2	POST	1	CC1046856
3	POST	1	CC1046857
4	POST	1	CC1046858
5	FRAME	1	200EDM314
6	FRAME	1	201EDM314
7	FRAME	1	202EDM314
8	FRAME	1	203EDM314
9	FRAME	1	204EDM314
10	FRAME	1	205EDM314
11	FRAME	1	206EDM314
12	FRAME	1	207EDM314
13	BRACE.....	1	CC1046862
14	BRACE.....	1	201EDM326
15	BRACE.....	1	202EDM326
16	DOOR – CANOPY	1	CC1046859
17	DOOR – CANOPY	2	CC1046860
18	PANEL	1	203EDM216
19	BRACKET	2	201EDM142
20	BRACKET	1	202EDM142

Order by Part Number and Description. Reference Numbers are for your convenience only.

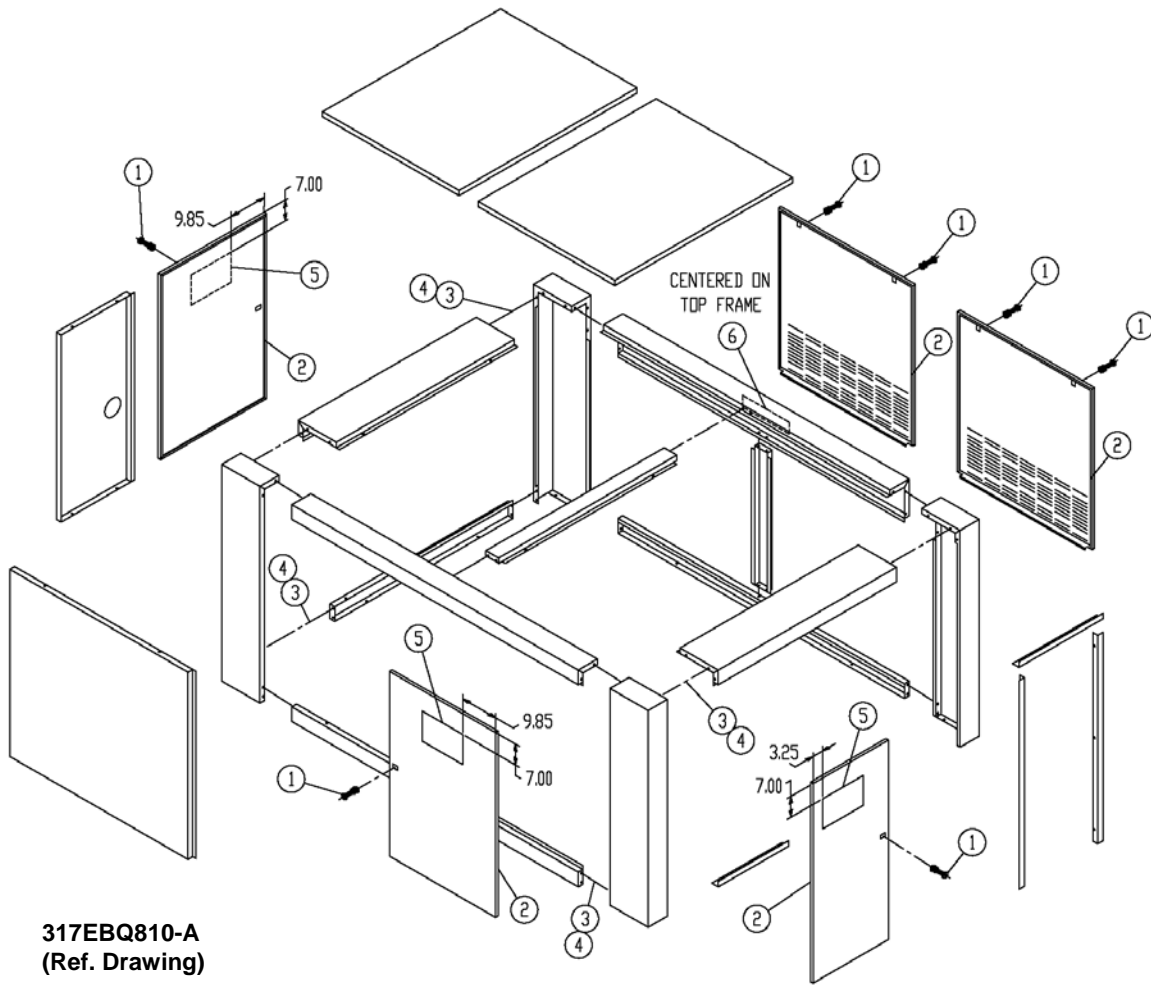

317EBQ810-A
(Ref. Drawing)

**ENCLOSURE – HARDWARE
(STANDARD & QUIET)**

B/M: 307EBQ4017

Ref. No.	Name of Part	Qty.	Part No.
1	LATCH.....	7	31D68
2	SEAL (IN FEET)	75	32E12
3	SCREW-FLANGED	90	75LM51
4	NUT	82	50AW5
5	DECAL.....	3	VP1042952
6	DECAL - "GARDNER DENVER".....	1	VP1044830
7	KEY (not shown).....	2	VP1049035

Order by Part Number and Description. Reference Numbers are for your convenience only.

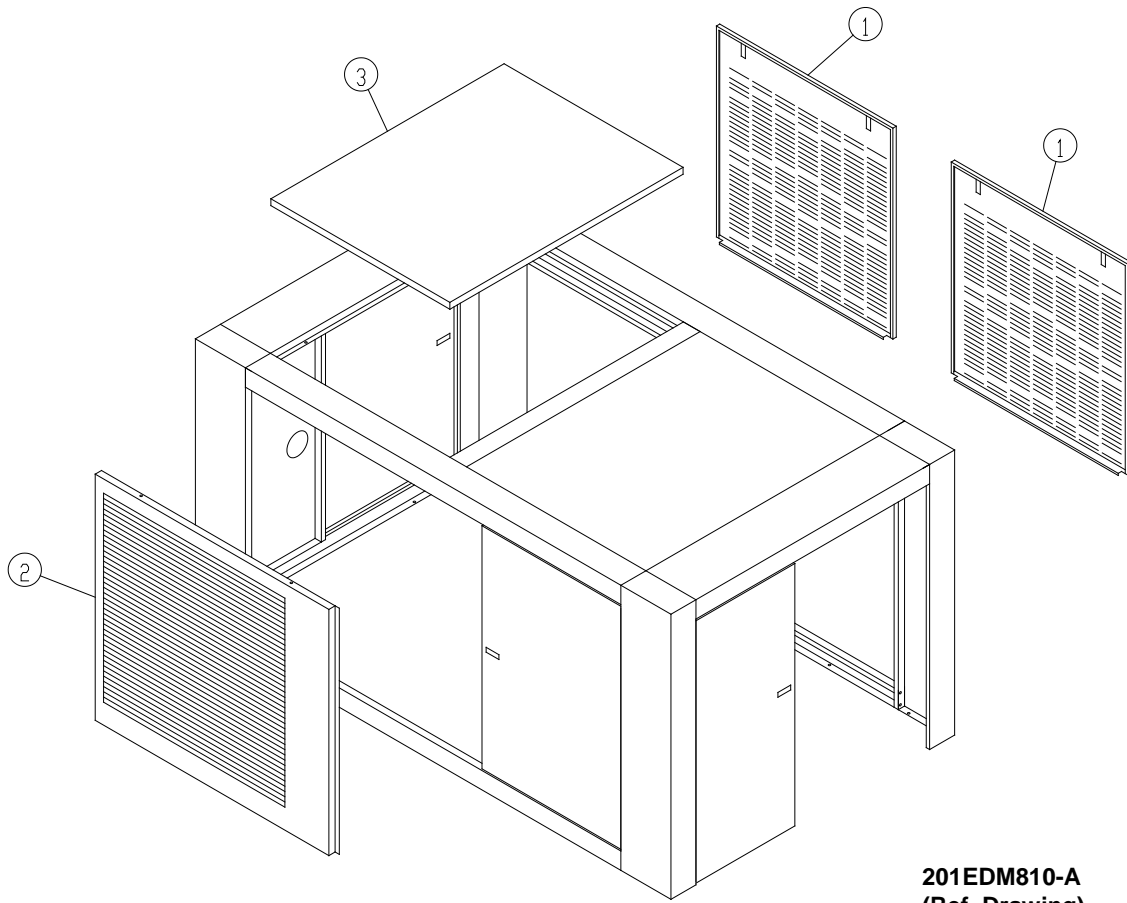

201EDM810-A
(Ref. Drawing)

**ENCLOSURE – AIR COOLED PANELS
(STANDARD)**

B/M: 201EDM4023

Ref. No.	Name of Part	Qty.	Part No.
1	PANEL.....	2	CC1018159
2	PANEL.....	1	202EDM216
3	PANEL.....	1	203EDM216

Order by Part Number and Description. Reference Numbers are for your convenience only.

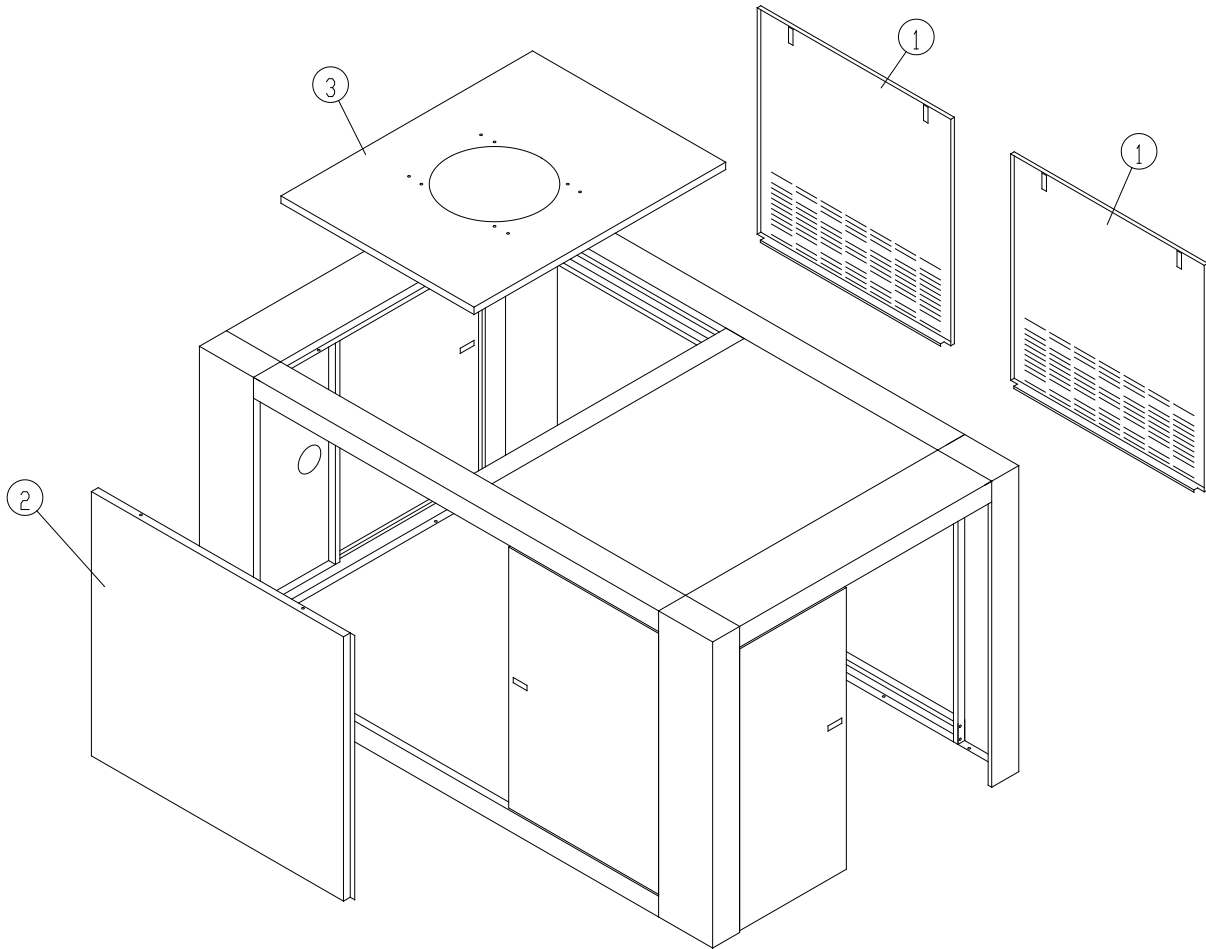

202EDM810
(Ref. Drawing)

**ENCLOSURE – WATER COOLED PANELS
(STANDARD)**

B/M: 202EDM4023

Ref. No.	Name of Part	Qty.	Part No.
1	PANEL	2	CC1018160
2	PANEL	1	204EDM216
3	PANEL	1	205EDM216

Order by Part Number and Description. Reference Numbers are for your convenience only.

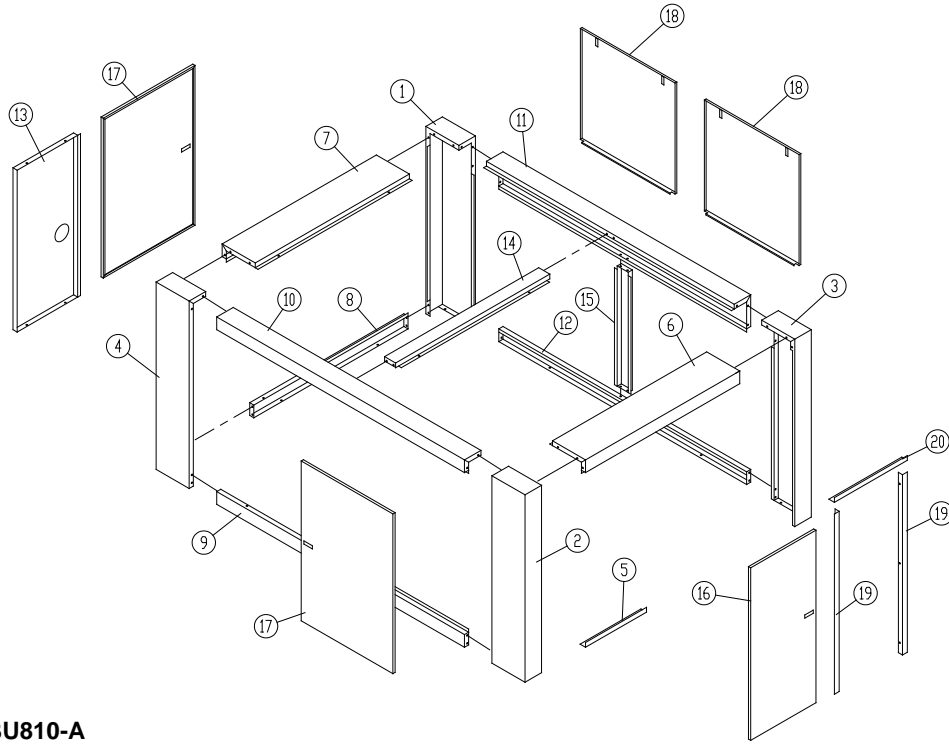

305EBU810-A
(Ref. Drawing)

**ENCLOSURE – BASIC
(QUIET)**

B/M: 301EBQ4023

Ref. No.	Name of Part	Qty.	Part No.
1	POST.....	1	CC1046854
2	POST.....	1	CC1046856
3	POST.....	1	CC1046857
4	POST.....	1	CC1046858
5	FRAME.....	1	200EDM314
6	FRAME.....	1	201EDM314
7	FRAME.....	1	202EDM314
8	FRAME.....	1	203EDM314
9	FRAME.....	1	204EDM314
10	FRAME.....	1	205EDM314
11	FRAME.....	1	206EDM314
12	FRAME.....	1	207EDM314
13	BRACE.....	1	CC1046864
14	BRACE.....	1	201EDM326
15	BRACE.....	1	202EDM326
16	DOOR.....	1	CC1046866
17	DOOR.....	2	CC1046865
18	PANEL.....	2	CC1018163
19	BRACKET.....	2	201EDM142
20	BRACKET.....	1	202EDM142

Order by Part Number and Description. Reference Numbers are for your convenience only.

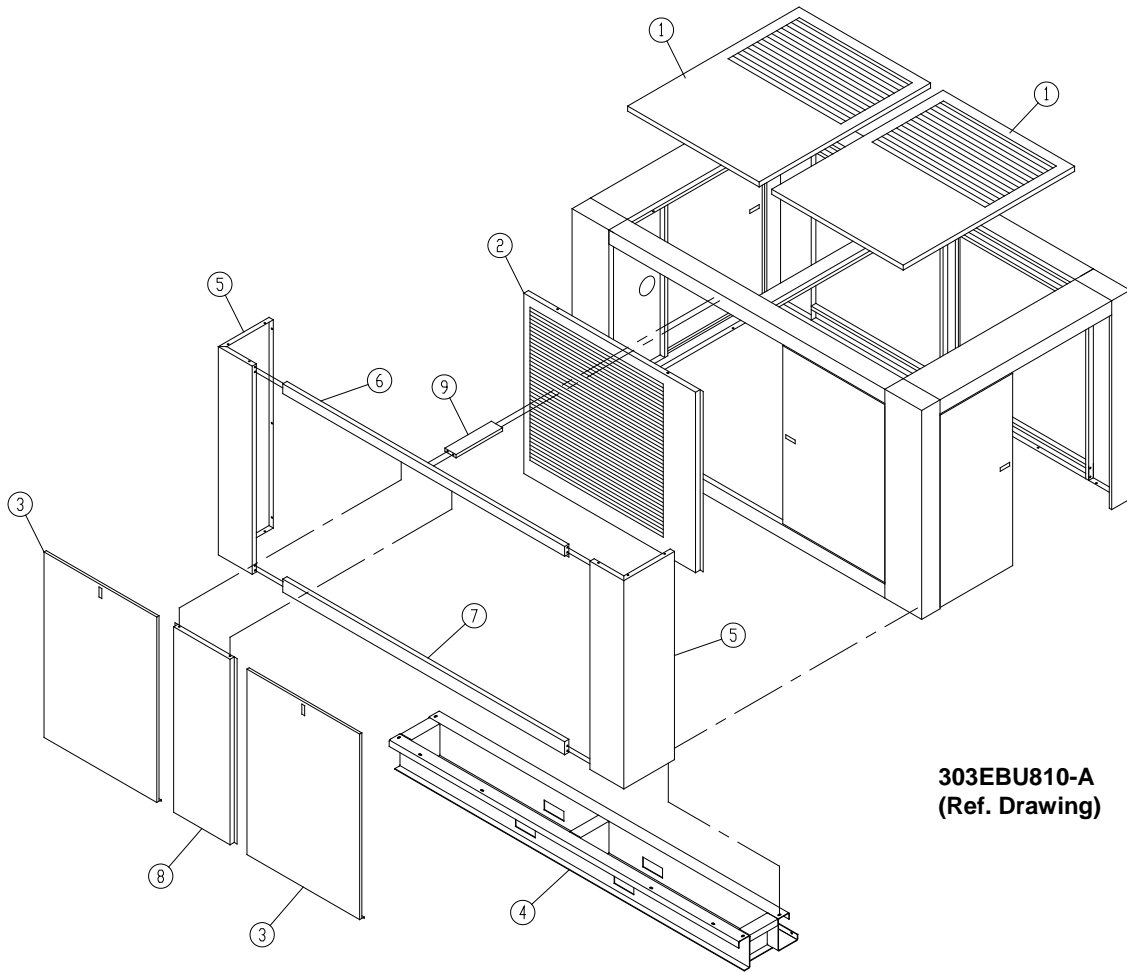

303EBU810-A
(Ref. Drawing)

**AIR COOLED BAFFLE
(QUIET)**

B/M: 302EBQ4023

Ref. No.	Name of Part	Qty.	Part No.
1	PANEL.....	2	300EBU216
2	PANEL.....	1	202EDM216
3	PANEL.....	2	CC1018164
4	BASE.....	1	300EBU285
5	POST.....	2	CC1046863
6	FRAME.....	1	300EBU314
7	FRAME.....	1	301EBU314
8	BRACE.....	1	301EBU326
9	BRACE.....	1	205EAU326

Order by Part Number and Description. Reference Numbers are for your convenience only.

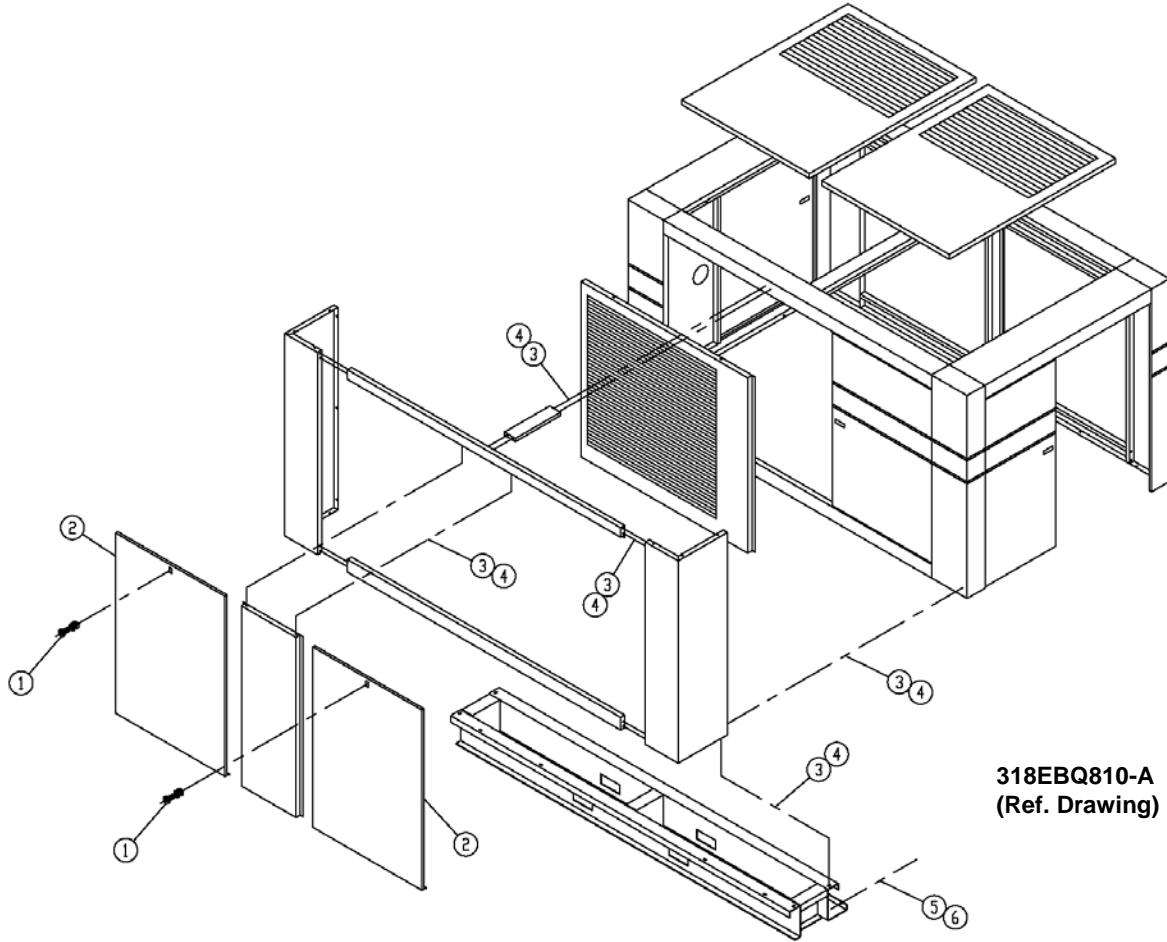

318EBQ810-A
(Ref. Drawing)

**AIR COOLED BAFFLE - HARDWARE
(QUIET)**

B/M: 308EAQ4017

Ref. No.	Name of Part	Qty.	Part No.
1	LATCH	2	31D68
2	SEAL (IN FEET)	25	32E12
3	SCREW.....	30	75LM51
4	NUT.....	30	50AW5
5	SCREW.....	4	75LM135
6	NUT.....	4	50AW35

Order by Part Number and Description. Reference Numbers are for your convenience only.

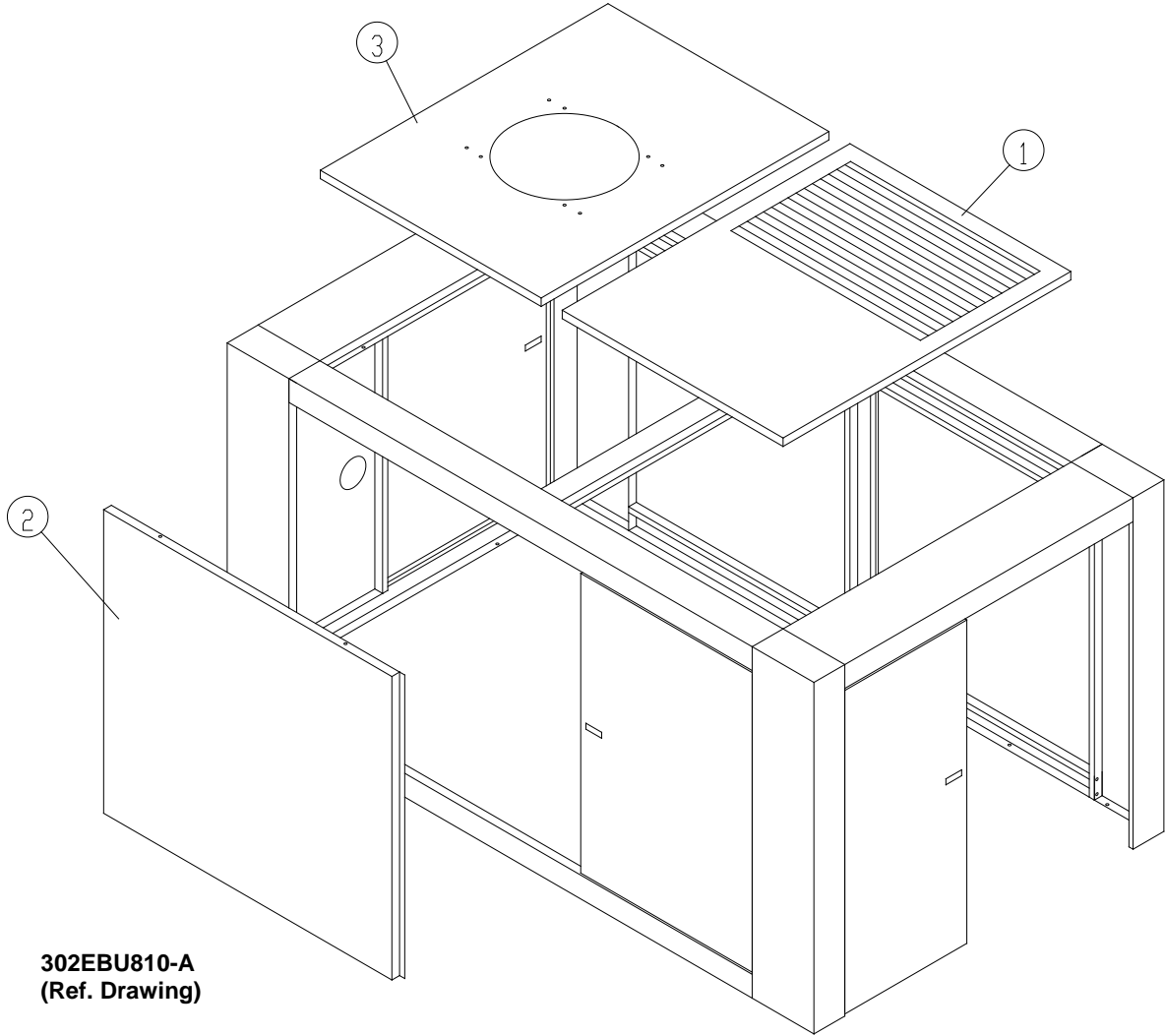

**ENCLOSURE – WATER COOLED
(QUIET)**

B/M: 300EBU4023

Ref. No.	Name of Part	Qty.	Part No.
1	PANEL.....	1	300EBU216
2	PANEL.....	1	302EBU216
3	PANEL.....	1	301EBU216

Order by Part Number and Description. Reference Numbers are for your convenience only.

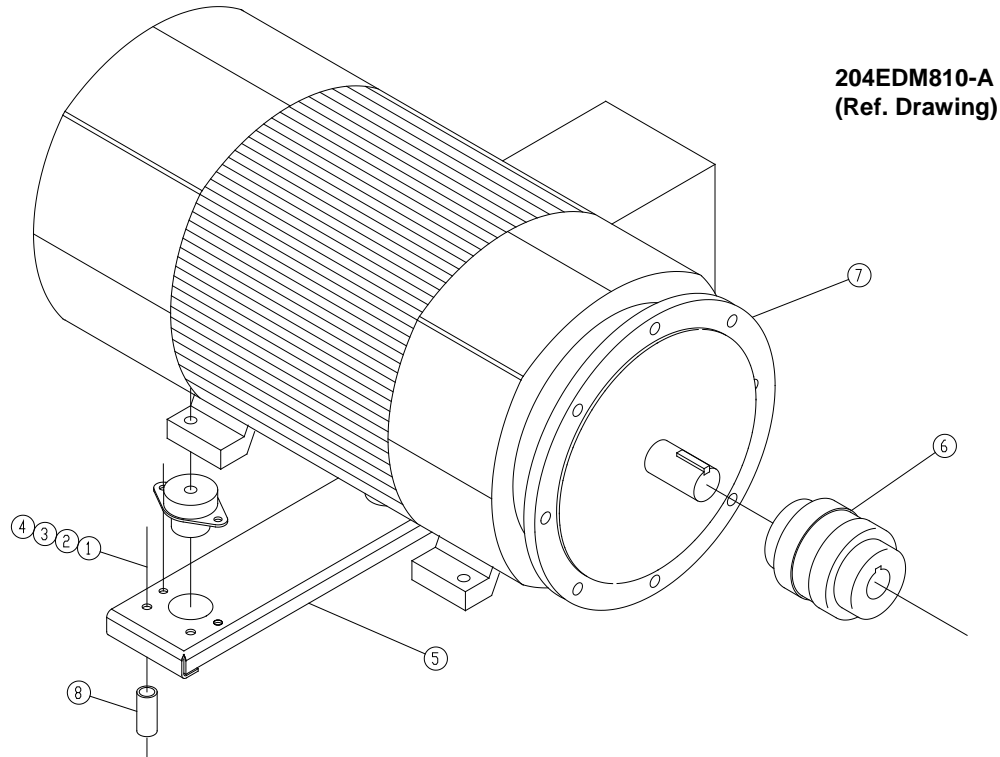

MAIN MOTOR GROUP

Ref. No.	Name of Part	Qty.	125 HP - ODP 100 & 125# -	125 HP - ODP 150#	125 HP - TEFC - 100 & 125 # 150 HP - ODP & TEFC - 100, 125 & 150 #	125 HP - TEFC 150#
			Part No.	Part No.	Part No.	Part No.
	AIREND		SSQ	SSP	SSQ	SSP
	MOTOR FRAME		404 & 405	404 & 405	444 - 449	444 - 449
1	WASHER	4	95A7	95A7	95A7	95A7
2	LOCKWASHER	4	95B7	95B7	95B7	95B7
3	NUT	4	50B7	50B7	50B7	50B7
4	SCREW	4	655EF180	655EF220	655EF160	655EF180
5	SUPPORT-MOTOR	1	201EDM620	300EBQ620	200EDM620	200EDP620
6	COUPLING FLEXIBLE	1	51L220	51L223	51L221	51L222
7	MOTOR	1	See Page 53	See Page 53	See Page 53	See Page 53
8	NIPPLE	4	63AM12X32G	63AM12X42G	63AM12X22G	63AM12X32G

NOTE: Drive Coupling Repair Spider Part Number 2118273.

51L220 Coupling (2-1/8 Motor Shaft Diameter – 2-5/8 Airend Shaft Diameter.)
 51L221 Coupling (2-3/8 Motor Shaft Diameter – 2-5/8 Airend Shaft Diameter.)
 51L222 Coupling (2-3/8 Motor Shaft Diameter – 2-1/8 Airend Shaft Diameter.)
 51L223 Coupling (2-1/8 Motor Shaft Diameter – 2-1/8 Airend Shaft Diameter.)

MOTOR LIST (MAIN DRIVE MOTORS)

Name of Part	Full 125 HP Part No.	Full 150 HP Part No.	Full 200 HP Part No.	Wye Delta 125 HP Part No.	Wye Delta 150 HP Part No.	Wye Delta 200 HP Part No.
---------------------	-------------------------------------	-------------------------------------	-------------------------------------	--	--	--

**OPEN DRIP PROOF
(60 HZ – ODP - EISA EFFICIENCY)**

MOTOR, 200V	24CA6391	24CA6407	N/A	24CA6399	24CA6415	N/A
MOTOR, 230V	24CA6392	24CA6408	24CA6423	24CA6400	24CA6416	24CA6429
MOTOR, 460V	24CA6393	24CA6409	24CA6424	24CA6401	24CA6417	24CA6430
MOTOR, 575V	24CA6394	24CA6410	24CA6425	24CA6402	24CA6418	24CA6431

**TOTALLY ENCLOSED FAN COOLED
(60 HZ – TEFC - EISA EFFICIENCY)**

MOTOR, 200V	24CA6395	24CA6411	N/A	24CA6403	24CA6419	N/A
MOTOR, 230V	24CA6396	24CA6412	24CA6426	24CA6404	24CA6420	24CA6432
MOTOR, 460V	24CA6397	24CA6413	24CA6427	24CA6405	24CA6421	24CA6433
MOTOR, 575V	24CA6398	24CA6414	24CA6428	24CA6406	24CA6422	24CA6434

MOTOR GROUP (FAN MOTORS) (125 & 150 HP)

**AIR COOLED FAN MOTOR (COOLING MODULE)
(T.E.F.C., 3 HP, 1200 RPM, 60 HZ., 1.33 S.F.)**

VOLTAGE	PART NO.
MOTOR, 200V	24CA6584
MOTOR, 230V	24CA6585
MOTOR, 460V	24CA6585
MOTOR, 575V	24CA6586

MOTOR GROUP (FAN MOTORS) (200 HP)

**AIR COOLED FAN MOTOR (COOLING MODULE)
(T.E.F.C., 5 HP, 1200 RPM, 60 HZ., 1.33 S.F.)**

VOLTAGE	PART NO.
MOTOR, 230V	24CA6587
MOTOR, 460V	24CA6587
MOTOR, 575V	24CA6588

**WATER COOLED FAN MOTOR (ENCLOSURE VENT FAN)
(T.E.F.C., 1200 RPM, 60 HZ., 1.0 S.F.)**

VOLTAGE	PART NO.	HP
MOTOR, 200V	24CA4177	1/4
MOTOR, 230V	24CA2464	1/4
MOTOR, 460V	24CA2464	1/4
MOTOR, 575V	24CA4178	1/4

Order by Part Number and Description. Reference Numbers are for your convenience only.

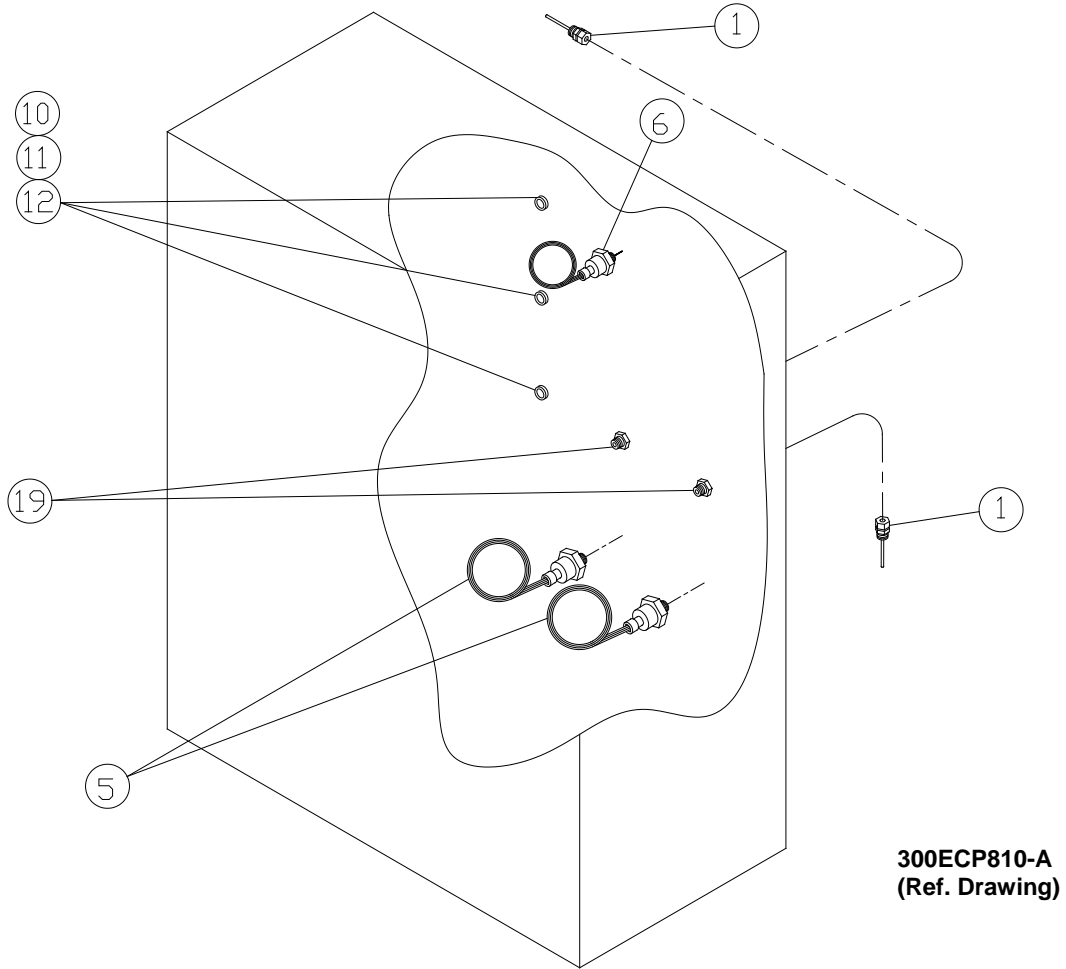

MISCELLANEOUS ELECTRICAL PARTS

B/M: 200ECP4007

Ref. No.	Name of Part	Qty.	Part No.
* 1	PROBE-ELECTRICAL.....	2	21D264
* 5	TRANSDUCER-PRESSURE.....	2	88H359
* 6	SWITCH-VACUUM.....	1	88H195
10	NIPPLE.....	3	24CA4641
11	O-RING.....	3	24A383
12	LOCKNUT-CONDUIT.....	3	24A77
19	FITTING-ELECTRICAL.....	2	24CA2865

* Parts included in Electrical Control Kit Part Number 306EAQ6013. Refer to page 68.

IDENTIFICATION AND INSTRUCTION GROUP

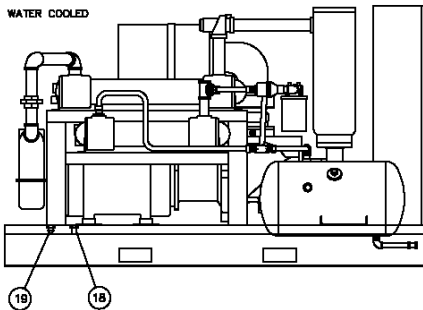
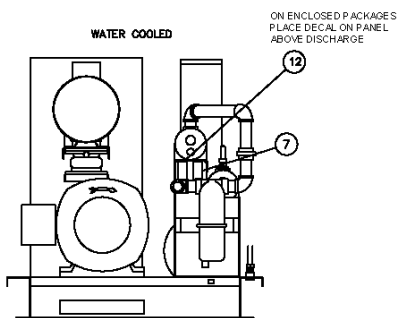
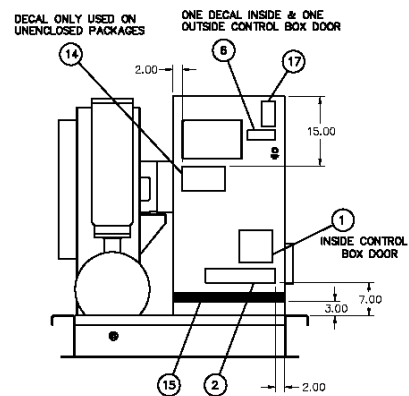
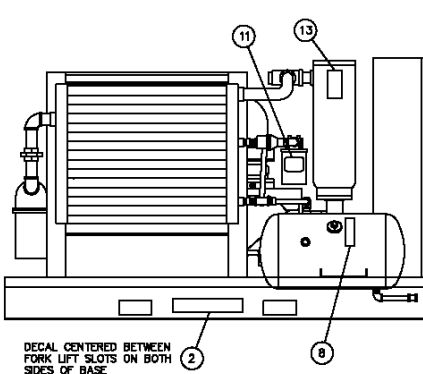
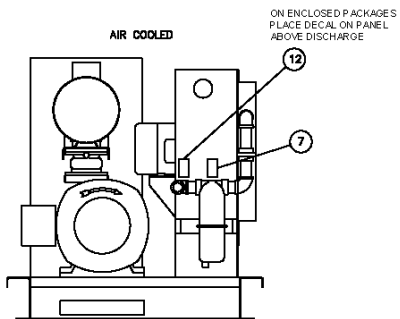
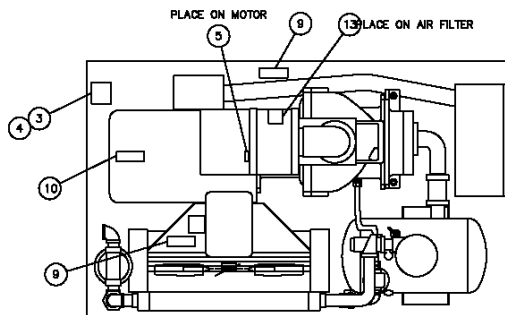

NOTE: DETAIL 16 ONE DECAL FRONT & BACK, BOTTOM EDGE
OF ENCLOSURE TOP FRAME & TOP EDGE OF DOOR.
(ENCLOSED PACKAGES ONLY)

**316EBQ810-A
(Ref. Drawing)**

IDENTIFICATION AND INSTRUCTION GROUP

**B/M: 309EAQ4011;
301, 303, 304EBQ4011**

Ref. No.	Name of Part	Qty.	Part No.
2	DECAL, ELECTRA SAVER (LARGE)	3	VP1044837
* 5	DECAL, ROTATION ARROW	1	304EFC077
* 6	DECAL, ISO WARNING –CONTROL BOX.....	2	VP1009371
* 7	DECAL, ISO WARNING – MOISTURE TRAP	1	VP1009380
* 8	DECAL, ISO WARNING – SEPARATOR TANK	1	VP1009376
* 9	DECAL, ISO WARNING – FAN/COOLER HOUSING.....	2	VP1009582
* 10	DECAL, ISO WARNING – MOTOR.....	1	VP1009374
11	DECAL, OIL FILL ELEMENT INSTALL.....	1	212ECM077
* 12	DECAL, ISO WARNING – PACKAGE DISCHARGE AIR	1	VP1009623
* 13	DECAL, NOTICE (USE GENUINE GD PARTS)	2	CC1009474
14	DECAL, GARDNER DENVER LOGO (SMALL).....	1	VP1051555
15	DECAL, STRIPE (LARGE)	1	VP1051552
* 16	DECAL, ISO WARNING (SIDES ABOVE DOORS).....	2	VP1009372
17	DECAL, CAGI PERFORMANCE	1	CC1031484
18	DECAL, HEAT EXCHANGE “IN”	1	200ESP077
19	DECAL, HEAT EXCHANGE “OUT”	1	201ESP077

* For Replacement Decals Order Part Number CC1010403 Decal Group Sheet.

**CONTROLLER ASSEMBLY
(125/150 HP WYE DELTA STARTERS)**

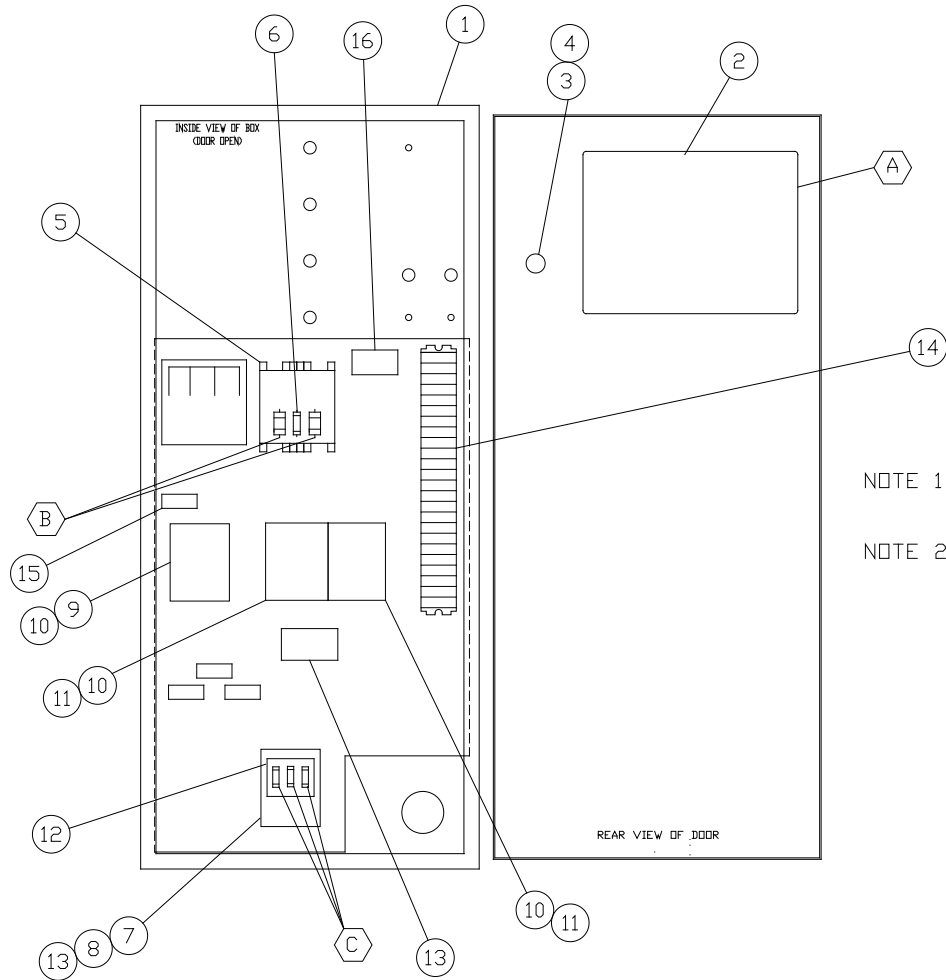

**302EAQ797-A
(Ref. Drawing)**

NOTE 1 - ITEMS 15 & 16 ARE USED ONLY ON PANELS WITH ES + AND CURRENT MONITORING.

NOTE 2 - ITEM 10 IS INCLUDED IN 9 & 11, ITEM 8 & 13 ARE INCLUDED IN 7.

**CONTROLLER ASSEMBLY
(125/150 HP WYE DELTA STARTERS)**

	QTY.	200V	230V	460V	575V
ASSEMBLED PANEL – ES+ : NEMA 12, W/O Current Monitor.....	1	202EAQ466	201EAQ466	200EAQ466	203EAQ466
ASSEMBLED PANEL – ES+ : NEMA 4, W/O Current Monitor.....	1	209EAQ466	208EAQ466	207EAQ466	210EAQ466
ASSEMBLED PANEL – ES+ : NEMA 12, With Current Monitor.....	1	228EAQ466	227EAQ466	226EAQ466	229EAQ466
ASSEMBLED PANEL – ES+ : NEMA 4, With Current Monitor.....	1	235EAQ466	234EAQ466	233EAQ466	236EAQ466
A FUSE, CONTROL BOARD (1A, AGC).....	1	24CA2932	24CA2932	24CA2932	24CA2932
B FUSE, TRANSFORMER PRIMARY (-A, FNQ-R).....	2	24CA2786 (6A)	24CA2785 (5A)	24CA2783 (3A)	24CA3722 (2.25A)
C FUSE FAN MOTOR					
AIR COOLED (-A, LP-CC)	3	24CA4321 (30A)	24CA4097 (25A)	24CA4096 (15A)	24CA4096 (15A)
WATER COOLED (-A, LP-CC)	3	24CA4093 (7A)	24CA4092 (6A)	24CA4090 (3A)	24CA4090 (3A)
1 CONTROL BOX					
NEMA 12	1	200EDM179	200EDM179	200EDM179	200EDM179
NEMA 4.....	1	201EDM179	201EDM179	201EDM179	201EDM179
* 2 ES+ CONTROLLER.....	1	302EAU2006	302EAU2006	302EAU2006	302EAU2006
3 OPERATOR	1	24CA2907	24CA2907	24CA2907	24CA2907
4 CONTACT BLOCK.....	1	24CA2908	24CA2908	24CA2908	24CA2908
5 TRANSFORMER.....	1	2116286	2118244	2118244	2118245
6 FUSE.....	1	24CA3729	24CA3729	24CA3729	24CA3729
7 STARTER	1	24CA4134	24CA4134	24CA4134	24CA4134
8 COIL-STARTER	1	2115950	2115950	2115950	2115950
9 STARTER-MAIN MOTOR	1	24CA3490	24CA3490	24CA3255	24CA3255
10 COIL.....	3	2115952	2115952	2116555	2116555
11 CONTACTOR	2	24CA3696	24CA3696	24CA3259	24CA3259
12 FUSE HOLDER.....	1	24CA4098	24CA4098	24CA4098	24CA4098
13 OVERLOAD RELAY.....	1	24CA4086	24CA4086	24CA4086	24CA4086
14 TERMINAL BLOCK	6	24CA2633	24CA2633	24CA2633	24CA2633
15 TRANSFORMER (With Current Monitor Only).....	1	24CA4242	24CA4242	24CA4242	24CA4242
16 TRANSDUCER (With Current Monitor Only).....	1	24CA4241	24CA4241	24CA4241	24CA4241

* Refer to page 66 for controller part numbers.

**CONTROLLER ASSEMBLY
(200 HP WYE DELTA STARTERS)**

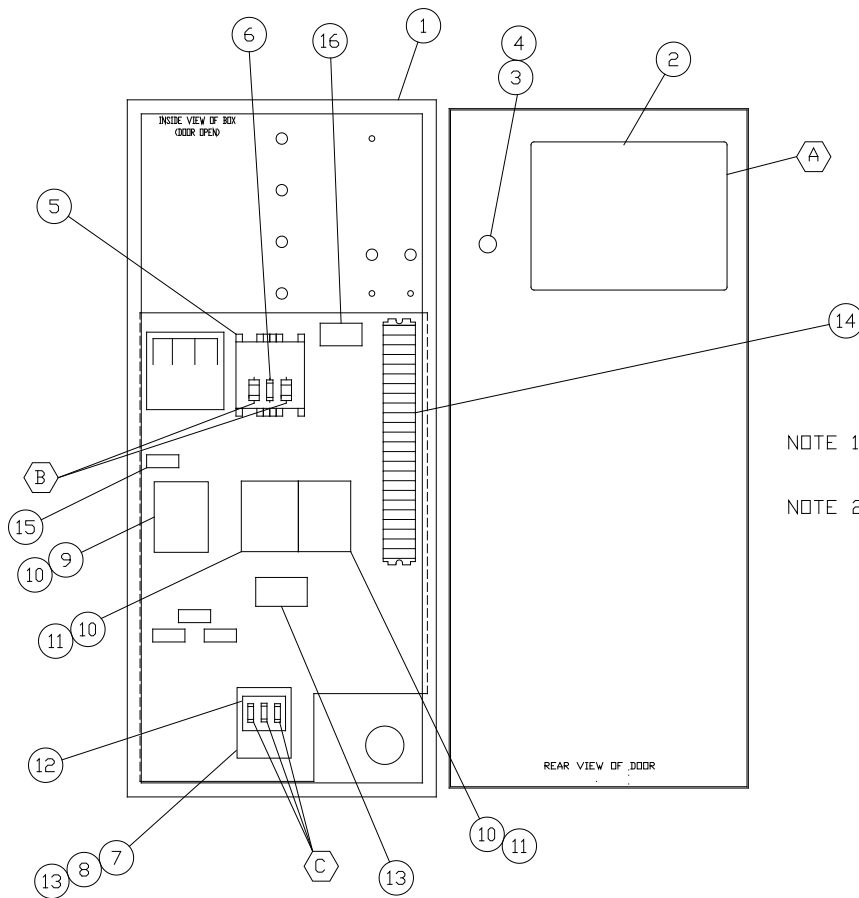

**302EAQ810-A
(Ref. Drawing)**

NOTE 1 - ITEMS 15 & 16 ARE USED ONLY ON PANELS WITH ES + AND CURRENT MONITORING.

NOTE 2 - ITEM 10 IS INCLUDED IN 9 & 11.
ITEM 8 & 13 ARE INCLUDED IN 7.

**CONTROLLER ASSEMBLY
(200 HP WYE DELTA STARTERS)**

	QTY.	460V	575V
ASSEMBLED PANEL – ES+ : NEMA 12, W/O Current Monitor.....	1	201EAQ466	203EAQ466
ASSEMBLED PANEL – ES+ : NEMA 4, W/O Current Monitor.....	1	208EAQ466	210EAQ466
ASSEMBLED PANEL – ES+ : NEMA 12, With Current Monitor.....	1	227EAQ466	229EAQ466
ASSEMBLED PANEL – ES+ : NEMA 4, With Current Monitor.....	1	234EAQ466	236EAQ466
A FUSE, CONTROL BOARD (1A, AGC).....	1	24CA2932	24CA2932
B FUSE, TRANSFORMER PRIMARY (-A, FNQ-R).....	2	24CA2783 (3A)	24CA3722 (2.25A)
C FUSE FAN MOTOR			
AIR COOLED (-A, LP-CC)	3	24CA4096 (15A)	24CA4096 (15A)
WATER COOLED (-A, LP-CC)	3	24CA4090 (3A)	24CA4090 (3A)
1 CONTROL BOX			
NEMA 12	1	200EDM179	200EDM179
NEMA 4	1	201EDM179	201EDM179
* 2 ES+ CONTROLLER	1	302EAU2006	302EAU2006
3 OPERATOR	1	24CA2907	24CA2907
4 CONTACT BLOCK	1	24CA2908	24CA2908
5 TRANSFORMER.....	1	2118244	2118245
6 FUSE.....	1	24CA3729	24CA3729
7 STARTER.....	1	24CA4134	24CA4134
8 COIL-STARTER	1	2115950	2115950
9 STARTER-MAIN MOTOR	1	24CA3490	24CA3255
10 COIL.....	3	2115952	2116555
11 CONTACTOR.....	2	24CA3696	24CA3259
12 FUSE HOLDER.....	1	24CA4098	24CA4098
13 OVERLOAD RELAY	1	24CA4086	24CA4086
14 TERMINAL BLOCK	6	24CA2633	24CA2633
15 TRANSFORMER (With Current Monitor Only)	1	24CA4242	24CA4242
16 TRANSDUCER (With Current Monitor Only).....	1	24CA4241	24CA4241

* Refer to page 66 for controller part numbers.

**CONTROLLER ASSEMBLY
125/150/200 HP – FULL VOLTAGE**

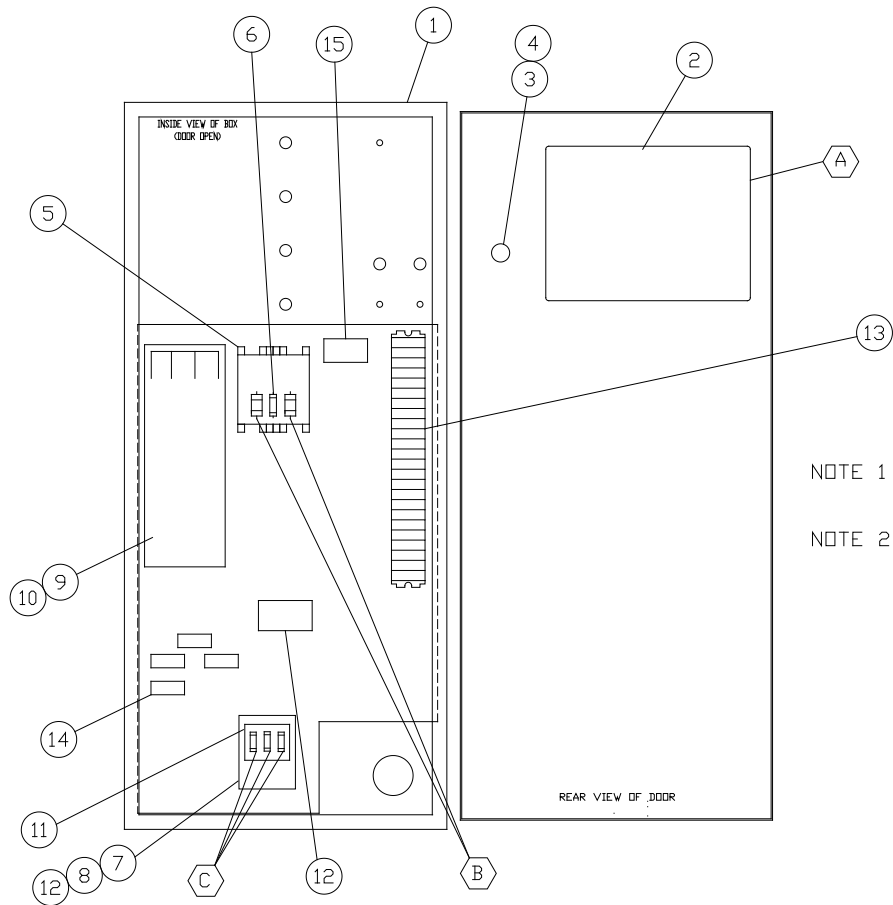

NOTE 1 - ITEMS 14 & 15 ARE USED ONLY ON PANELS WITH ES + AND CURRENT MONITORING.

NOTE 2 - ITEM 10 IS INCLUDED IN 9. ITEMS 8 & 12 ARE INCLUDED IN 7.

**301EAQ797-A
(Ref. Drawing)**

Order by Part Number and Description. Reference Numbers are for your convenience only.

**CONTROLLER ASSEMBLY
125/150/200 HP – FULL VOLTAGE**

		QTY.	460V	575V
	ASSEMBLED PANEL – ES+ : NEMA 12, W/O Current Monitor.....	1	214EAQ466	215EAQ466
	ASSEMBLED PANEL – ES+ : NEMA 4, W/O Current Monitor.....	1	216EAQ466	217EAQ466
	ASSEMBLED PANEL – ES+ : NEMA 12, With Current Monitor.....	1	240EAQ466	241EAQ466
	ASSEMBLED PANEL – ES+ : NEMA 4, With Current Monitor.....	1	242EAQ466	243EAQ466
A	FUSE, CONTROL BOARD (1A, AGC).....	1	24CA2932	24CA2932
B	FUSE, TRANSFORMER PRIMARY (-A, FNQ-R).....	2	24CA2783 (3A)	24CA3722 (2.25A)
C	FUSE FAN MOTOR			
	AIR COOLED (-A, LP-CC)	3	24CA4096 (15A)	24CA4096 (15A)
	WATER COOLED (-A, LP-CC).....	3	24CA4090 (3A)	24CA4090 (3A)
1	CONTROL BOX			
	NEMA 12	1	200EDM179	200EDM179
	NEMA 4	1	201EDM179	201EDM179
*	2 ES+ CONTROLLER	1	302EAU2006	302EAU2006
	3 OPERATOR	1	24CA2907	24CA2907
	4 CONTACT BLOCK	1	24CA2908	24CA2908
	5 TRANSFORMER.....	1	2118244	2118245
	6 FUSE.....	1	24CA3729	24CA3729
	7 STARTER.....	1	24CA4134	24CA4134
	8 COIL-STARTER	1	2115950	2115950
	9 STARTER-MAIN MOTOR	1	24CA3490	24CA3490
	10 COIL	1	2115952	2115952
	11 FUSE HOLDER	1	24CA4098	24CA4098
	12 OVERLOAD RELAY	2	24CA4086	24CA4086
	12 TERMINAL BLOCK	6	24CA2633	24CA2633
	14 TRANSFORMER (with current monitor only)	1	24CA4242	24CA4242
	15 TRANSDUCER (with current monitor only)	1	24CA4241	24CA4241

* Refer to page 66 for controller part numbers.

**CONTROLLER ASSEMBLY
(LESS MAIN MOTOR STARTER)**

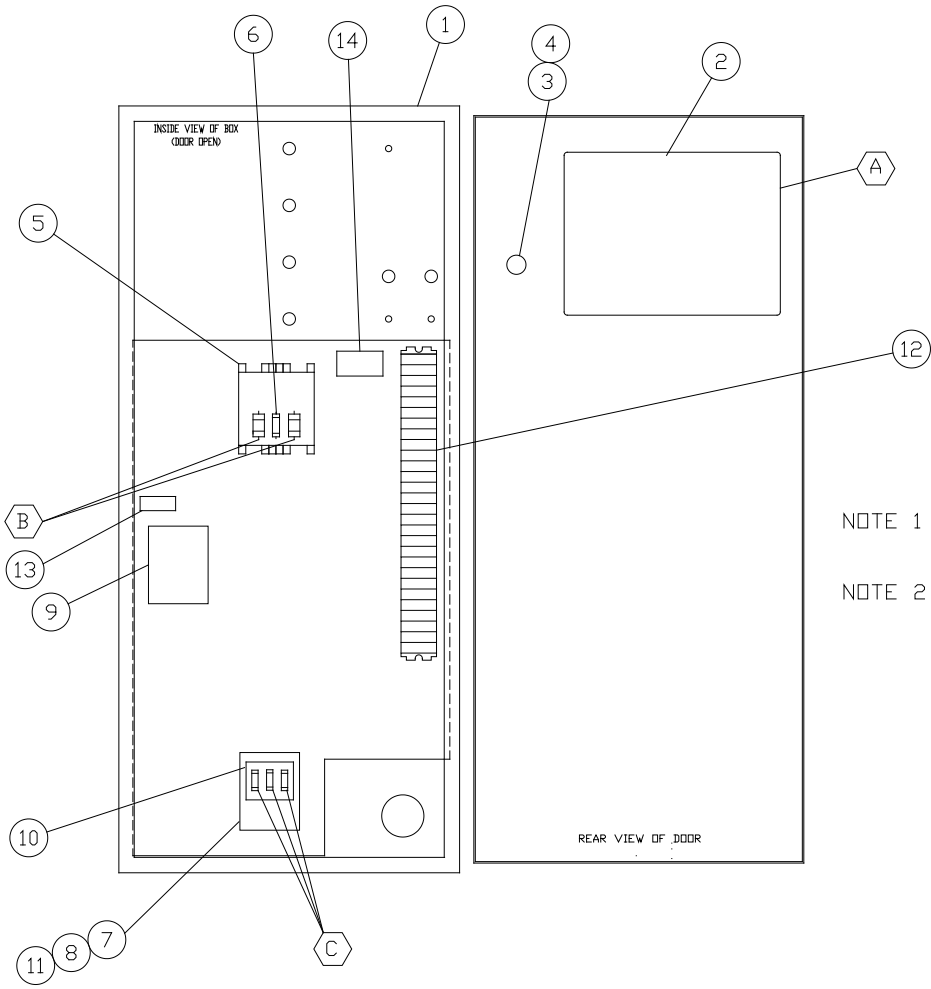

**303EAQ797-A
(Ref. Drawing)**

NOTE 1 - ITEMS 13 & 14 ARE USED ONLY ON PANELS WITH ES + AND CURRENT MONITORING.

NOTE 2 - ITEMS 8 & 11 ARE INCLUDED IN 7.

**CONTROLLER ASSEMBLY
(LESS MAIN MOTOR STARTER)**

	QTY.	200V	230V	460V	575V
		125 – 150 HP	125 – 200 HP	125 – 200 HP	125 – 200 HP
ASSEMBLED PANEL – ES+ : NEMA 12, W/O Current Monitor	1	219EAQ466	218EAQ466	218EAQ466	220EAQ466
ASSEMBLED PANEL – ES+ : NEMA 4, W/O Current Monitor	1	223EAQ466	222EAQ466	222EAQ466	224EAQ466
ASSEMBLED PANEL – ES+ : NEMA 12, With Current Monitor	1	245EAQ466	244EAQ466	244EAQ466	246EAQ466
ASSEMBLED PANEL – ES+ : NEMA 4, With Current Monitor	1	249EAQ466	248EAQ466	248EAQ466	250EAQ466
A FUSE, CONTROL BOARD (1A, AGC)	1	24CA2932	24CA2932	24CA2932	24CA2932
B FUSE, TRANSFORMER PRIMARY (-A, FNQ-R)	2	24CA2786 (6A)	24CA2785 (5A)	24CA2783 (3A)	24CA3722 (2.25A)
C FUSE FAN MOTOR					
AIR COOLED (-A, LP-CC).....	3	24CA4321 (30A)	24CA4097 (25A)	24CA4094 (15A)	24CA4092 (6A)
WATER COOLED (-A, LP-CC).....	3	24CA4093 (7A)	24CA4092 (6A)	24CA4090 (3A)	24CA4090 (3A)
1 CONTROL BOX					
NEMA 12.....	1	200EDM179	200EDM179	200EDM179	200EDM179
NEMA 4.....	1	201EDM179	201EDM179	201EDM179	201EDM179
* 2 ES+ CONTROLLER.....	1	302EAU2006	302EAU2006	302EAU2006	302EAU2006
3 OPERATOR.....	1	24CA2907	24CA2907	24CA2907	24CA2907
4 CONTACT BLOCK	1	24CA2908	24CA2908	24CA2908	24CA2908
5 TRANSFORMER	1	2116286	2116287	2116287	2116288
6 FUSE	1	24CA3729	24CA3729	24CA3729	24CA3729
7 STARTER	1	24CA4134	24CA4134	24CA4134	24CA4134
8 COIL-STARTER.....	1	2115950	2115950	2115950	2115950
9 CONTROL RELAY.....	1	24CA3896	24CA3896	24CA3896	24CA3896
10 FUSE HOLDER	1	24CA4098	24CA4098	24CA4098	24CA4098
11 OVERLOAD RELAY	1	24CA4086	24CA4086	24CA4086	24CA4086
12 TERMINAL BLOCK.....	7	24CA2633	24CA2633	24CA2633	24CA2633
13 TRANSFORMER (With Current Monitor Only).....	1	24CA4242	24CA4242	24CA4242	24CA4242
14 TRANSDUCER (With Current Monitor Only)	1	24CA4241	24CA4241	24CA4241	24CA4241

* Refer to Page 66 for controller part numbers.

Order by Part Number and Description. Reference Numbers are for your convenience only.

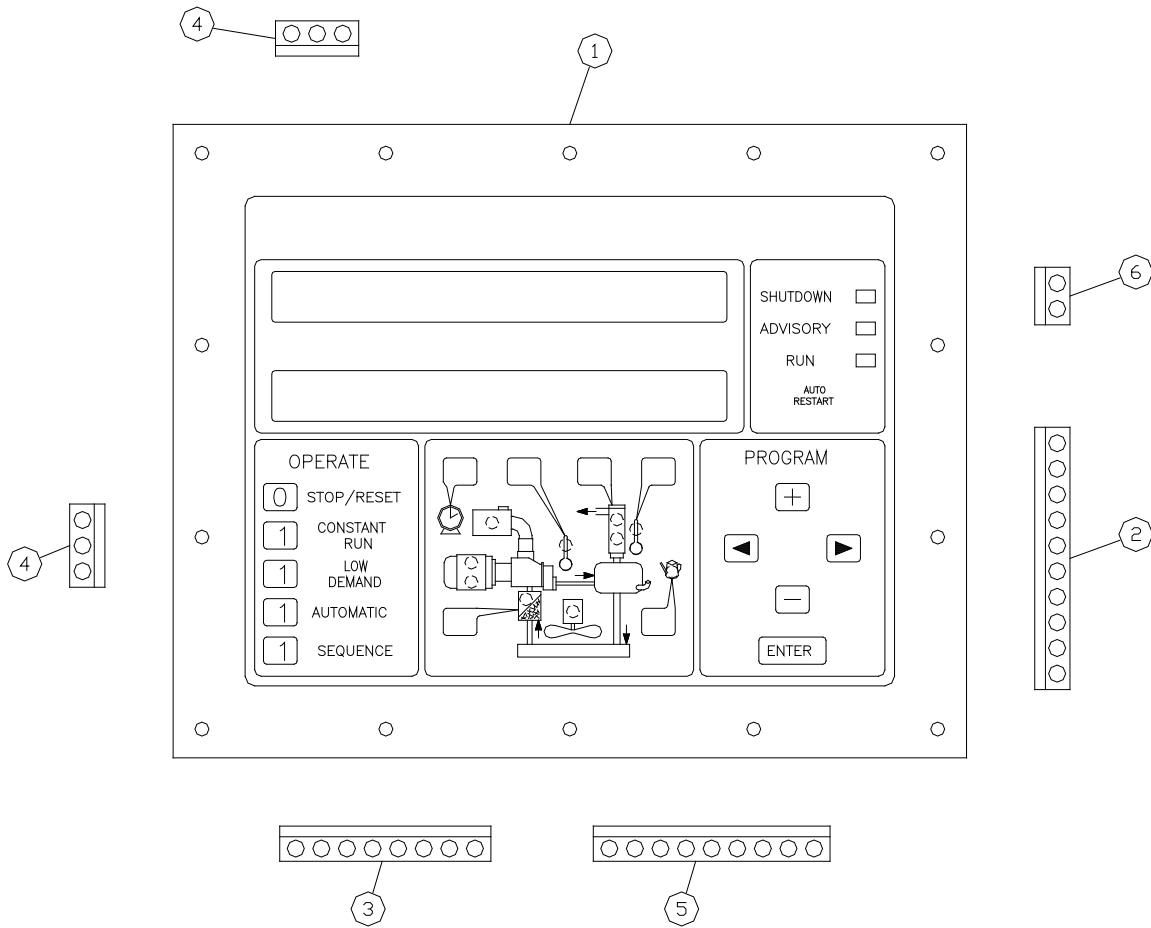

327EAU810-B
(Ref. Drawing)

CONTROLLER ASSEMBLY

B/M: 302EAU2006

Ref. No.	Name of Part	Qty.	Part No.
1	CONTROLLER, AUTO SENTRY ES+.....	1	302EAU1173
2	PLUG-CONNECTOR 10 PIN TERMINAL	1	24CA3306
3	PLUG-CONNECTOR 8 PIN TERMINAL	1	24CA3400
4	PLUG-CONNECTOR 3 PIN TERMINAL	2	24CA3401
5	PLUG-CONNECTOR 9 PIN TERMINAL	1	24CA3402
6	PLUG-CONNECTOR 2 PIN TERMINAL	1	24CA4240

OVERLOAD RELAY HEATER CONVERSION LISTING

Refer to Motor Nameplate “Amperage” and Decal in Control Panel for Selection of Overload Relay Heater Packs

CUTLER-HAMMER PART NUMBER	GARDNER DENVER PART NUMBER
H2002B	24CA4101
H2003B	24CA4102
H2004B	24CA4103
H2005B	24CA4104
H2006B	24CA4105
H2007B	24CA4106
H2008B	24CA4107
H2009B	24CA4108
H2010B	24CA4109
H2011B	24CA4110
H2012B	24CA4111
H2013B	24CA4112
H2014B	24CA4113
H2015B	24CA4114
H2016B	24CA4115
H2017B	24CA4116
H2018	24CA2924
H2019	24CA2925
H2020	24CA2926
H2021	24CA2927
H2022	24CA2893
H2023	24CA2894
H2024	24CA2928

REPAIR KITS

Your Gardner Denver rotary screw compressor is designed and manufactured for many years of reliable operation. All components are engineered to exacting specifications, which will function together as a system to provide maximum efficiency. To insure the continuing integrity of compressor operation, use only original quality genuine Gardner Denver replacement parts and accessories.

Name of Part	Qty.	Part No.
ROUTINE MAINTENANCE KIT (Heavy Duty Air Filter)		303EBQ6013
ELEMENT, AIR FILTER.....	2	2118349
ELEMENT, OIL FILTER.....	3	2118342
OIL SEPARATOR KIT.....		305EBQ6013
OIL SEPARATOR.....	1	VP1040693
GASKET ELIMINATOR	1	25BC222
LUBRICANT (Oil Seal Grease).....	1	2116755
PNEUMATIC CONTROLS AND GAUGES.....		302EAQ6013
CHECK VALVE.....	3	90AR261
CONTROL VALVE.....	1	90AR1034
CONTROL VALVE.....	1	90AR1082
PRESSURE REGULATOR.....	1	88H367
PRESSURE GAUGE	1	2118767
ELECTRICAL CONTROL GROUP		306EAQ6013
SOLENOID VALVE	1	91B70
SOLENOID VALVE	1	91B143
SOLENOID VALVE.....	1	91B144
ELECTRICAL PROBE	2	21D264
TRANSDUCER	2	88H359
VACUUM SWITCH	1	88H195
TOUCH-UP PAINT.....		
5 GALLON PAIL (WHITE).....	1	28H76
1 GALLON CAN (WHITE).....	1	28H84
1 QUART CAN (WHITE).....	1	28H83
5 GALLON PAIL (RED).....	1	28H325
1 GALLON CAN (RED).....	1	28H324
1 QUART CAN (RED).....	1	28H323
TURN VALVE ACTUATOR O-RING KIT		307EAQ6013
O-RING (Top to Stem).....	2	25BC738
O-RING (Body to Manifold, Large)	2	25BC37
O-RING (Body to Manifold, Small).....	2	25BC35
O-RING (Tube)	2	2009224
WATER TEMPERATURE REGULATOR (Optional).....		90AR151
MAGNETIC WATER SHUTOFF VALVE – NEMA 4 (Optional)		91B173

REPAIR KITS (Continued)

Name of Part	Qty.	Part No.
LUBRICANT (AEON 9000SP) – STANDARD		
5-GALLON PAIL	1	28H109
55-GALLON DRUM	1	28H103
LUBRICANT (AEON 9000TH)		
5-GALLON PAIL	1	28H286
55-GALLON DRUM	1	28H270
LUBRICANT (AEON 6000FG)		
5-GALLON PAIL	1	28H99
55-GALLON DRUM	1	28H100
LUBRICANT (AEON 6000FG-68)		
5-GALLON PAIL	1	28H314
55-GALLON DRUM	1	28H315
LUBRICANT (AEON BIO)		
5-GALLON PAIL	1	28H102
55-GALLON DRUM	1	28H103

AIREND REPAIR KITS (REFER TO PAGE 1 FOR SELECTION)

PERIODIC MAINTENANCE KIT (Inlet Valve).....		301EAQ6013
O-RING	1	25BC298
SPRING	1	78W62
SPRING	1	78W61
O-RING	1	25AM30
RETAINING RING	1	74D89
GASKET ELIMINATOR	1	25BC222
BEARING KIT		323SSP6013
ROLLER BEARING	1	12BA105
ROLLER BEARING	1	12BA198
ROLLER BEARING	1	12BA104
ROLLER BEARING	1	12BA103
SPRING	1	78W98
BEARING KIT		314SSQ6013
ROLLER BEARING	2	12BA126
BEARING	2	12BA251
BEARING	1	12BA192
SPRING	1	78W89
SPRING	1	78W109

REPAIR KITS (Continued)

Name of Part	Qty.	Part No.
GASKET KIT		315SSQ6013
GASKET ELIMINATOR	1	25BC222
SHIM SET	1	77H50
SHIM SET	1	77H107
GASKET KIT		324SSP6013
SHIM SET	1	77H63
SHIM SET	1	77H62
GASKET ELIMINATOR	1	25BC222
OIL SEAL KIT		200SSQ6007
WEAR SLEEVE	1	80M28
OIL SEAL	1	60DD571
OIL SEAL	1	60DD689
O-RING	1	25BC157
O-RING	1	25BC431
GASKET ELIMINATOR	1	25BC222
CHECK VALVE	1	90AR923
OIL SEAL KIT		300SSP6013
O-RING	1	8502140
O-RING	1	25BC380
OIL SEAL	1	60DD692
OIL SEAL	1	60DD693
WEAR SLEEVE	1	80M40
GASKET ELIMINATOR	1	25BC222
CHECK VALVE	1	90AR923
WEAR SLEEVE INSTALLATION/REMOVAL KIT		200SSQ4017
PULLER	1	200SSQ219
PULLER PLATE	1	300SSQ340
SCREW	1	655EE030
SCREW	1	655ED120A
SCREW	2	75D176
GUIDE	1	200SSQ450
TOOL	1	200SSQ074

REPAIR KITS (Continued)

Name of Part	Qty.	Part No.
WEAR SLEEVE INSTALLATION/REMOVAL KIT		200SSP4017
PULLER	1	200SSP219
PULLER PLATE.....	1	200SSP340
SCREW.....	1	75LM192
SCREW.....	1	655ED120A
SCREW.....	2	75D177
GUIDE.....	1	200SSP450
TOOL	1	200SSP074
TURN VALVE REPAIR KIT.....		325SSP6013
ROLLER BEARING	2	12BA51
KEY	1	35C114
SPRING	1	78W50
PACKING RING.....	4	60AM46
GASKET.....	4	25BC138N
SEAL-FASTENER	2	60DD801
BUMPER.....	2	32E15
PLATE-RETAINER	2	300SSU168
RETAINING RING	2	74D49
SEAL-FASTENER	2	60DD65

Gardner Denver®

For additional information, contact your local representative or visit:
www.contactgd.com/compressors

©2012 Gardner Denver, Inc. Printed in U.S.A.

