



ROTARY SCREW AIR COMPRESSOR ES-8 Series

Standard and Basic Models

15, 20, 25 and 30 HP

11, 15, 18.5 and 22KW

**OPERATOR'S
MANUAL AND
PARTS LIST**

**KEEP FOR
FUTURE
REFERENCE**

Part Number 02250117-368
©Sullair Corporation

AIR CARE SEMINAR TRAINING

Sullair Air Care Seminars are 3-day courses that provide hands-on instruction in the proper operation, maintenance and service of Sullair equipment. Individual seminars on Industrial compressors and compressor electrical systems are presented at regular intervals throughout the year at a dedicated training facility at Sullair's corporate headquarters in Michigan City, Indiana.

Instruction includes discussion of the function and installation of Sullair service parts, troubleshooting of the most common problems, and actual equipment operation. The seminars are recommended for maintenance and service personnel.

For detailed course outlines, schedule and cost information contact:

Sullair Corporate Training Department
1-888-SULLAIR or 219-879-5451 (ext. 5363)

- Or Write -

Sullair Corporation
3700 E. Michigan Blvd.
Michigan City, IN 46360
Attn: Service Training Department



**OPERATOR IS REQUIRED TO READ
ENTIRE INSTRUCTION MANUAL**

TABLE OF CONTENTS

Section 1 SAFETY

PAGE

1	1.1 GENERAL
1	1.2 PERSONAL PROTECTIVE EQUIPMENT
1	1.3 PRESSURE RELEASE
2	1.4 FIRE AND EXPLOSION
2	1.5 MOVING PARTS
2	1.6 HOT SURFACES, SHARP EDGES AND SHARP CORNERS
2	1.7 TOXIC AND IRRITATING SUBSTANCES
3	1.8 ELECTRICAL SHOCK
3	1.9 LIFTING
4	1.10 ENTRAPMENT

Section 2 INSTALLATION

5	2.1 LOCATION OF COMPRESSOR
5	2.2 VENTILATION AND COOLING
5	2.3 SERVICE AIR PIPING
5	2.4 COUPLING ALIGNMENT CHECK
5	2.5 FLUID LEVEL CHECK
6	2.6 MOTOR ROTATION DIRECTION CHECK
6	2.7 ELECTRICAL PREPARATION

Section 3 SPECIFICATIONS

7	3.1 SPECIFICATIONS- ES-8
8	3.2 LUBRICATION GUIDE
8	3.3 LUBRICANT CHANGE RECOMMENDATIONS

Section 4 COMPRESSOR SYSTEMS

13	4.1 INTRODUCTION
13	4.2 DESCRIPTION OF COMPONENTS
13	4.3 ENCAPSULATED COMPRESSOR SYSTEM, FUNCTIONAL DESCRIPTION
13	4.4 COMPRESSOR COOLING SYSTEM, FUNCTIONAL DESCRIPTION
13	4.5 AIR INLET SYSTEM, FUNCTIONAL DESCRIPTION
15	4.6 CONTROL SYSTEM, FUNCTIONAL DESCRIPTION

TABLE OF CONTENTS

(CONTINUED)

Section 5 **SUPERVISOR II**

PAGE	
19	5.1 INTRODUCTION
19	5.2 KEYPAD
19	5.3 STATUS DISPLAYS
20	5.4 LAMP INDICATORS

Section 6 **COMPRESSOR OPERATION- SUPERVISOR II**

21	6.1 INTRODUCTION
21	6.2 STANDARD PARAMETER SETUP
21	6.3 SEQUENCING PARAMETERS SETUP
22	6.4 OPERATING THE COMPRESSOR
23	6.5 PURPOSE OF CONTROLS
24	6.6 SUPERVISOR OUTPUT RELAYS
24	6.7 INITIAL START-UP PROCEDURE
24	6.8 SUBSEQUENT START-UP PROCEDURE
24	6.9 SHUTDOWN PROCEDURE

Section 7 **COMPRESSOR OPERATION- ELECTRO-MECHANICAL**

25	7.1 INTRODUCTION
25	7.2 PURPOSE OF CONTROLS- ELECTRO-MECHANICAL
26	7.3 INITIAL START-UP PROCEDURE
26	7.4 SUBSEQUENT START-UP PROCEDURE
26	7.5 SHUTDOWN PROCEDURE

Section 8 **MAINTENANCE**

27	8.1 INTRODUCTION
27	8.2 DAILY OPERATION
27	8.3 MOTOR BEARING LUBRICATION
27	8.4 FLUID FILTER MAINTENANCE
27	8.5 COOLER MAINTENANCE
28	8.6 PARTS REPLACEMENT AND ADJUSTMENT PROCEDURES
28	RELIEF VALVE
28	FLUID FILTER REPLACEMENT
28	AIR FILTER MAINTENANCE- STANDARD MODEL
29	AIR FILTER MAINTENANCE- BASIC MODEL
29	SEPARATOR ELEMENT REPLACEMENT
29	DRIVE COUPLING INSTALLATION
30	INLET CONTROL VALVE

TABLE OF CONTENTS

(CONTINUED)

Section 8

MAINTENANCE (CONT)

30	CONTROL SYSTEM ADJUSTMENT- ELECTRO-MECHANICAL
32	8.7 MAINTENANCE RECORD

Section 9

TROUBLESHOOTING

33	9.1 INTRODUCTION
33	9.2 TROUBLESHOOTING
34	9.3 CALIBRATION

Section 10

ILLUSTRATIONS AND PARTS LIST

	PAGE
37	10.1 PROCEDURE FOR ORDERING PARTS
37	10.2 RECOMMENDED SPARE PARTS LIST
38	10.3 INLET CONTROL, SEAL/DRIVE GEAR AND PARTS
42	10.4 MOTOR, COUPLING, FAN AND PARTS
44	10.5 INLET FILTER, COMPRESSOR HOUSING/SUMP AND PARTS- SUPERVISOR II
48	10.6 INLET FILTER, COMPRESSOR HOUSING/SUMP AND PARTS- ELECTRO-MECHANICAL
50	10.7 COMPRESSOR COOLER SYSTEM AND PARTS
52	10.8 CONTROL BOX AND PARTS- SUPERVISOR II
56	10.9 CONTROL BOX AND PARTS- ELECTRO-MECHANICAL
58	10.10 INSTRUMENT PANEL- ELECTRO-MECHANICAL
60	10.11 ENCLOSURE
62	10.12 DECAL GROUP
68	10.13 DECAL LOCATIONS
72	10.14 DECAL LOCATIONS- ENCLOSURE
74	10.15 WIRING DIAGRAM - FULL VOLTAGE- ELECTRO-MECHANICAL
75	10.16 WIRING DIAGRAM - FULL VOLTAGE- SUPERVISOR II
76	10.17 WIRING DIAGRAM - WYE-DELTA ELECTRO-MECHANICAL
77	10.18 WIRING DIAGRAM - WYE-DELTA SUPERVISOR II
78	10.19 WIRING DIAGRAM - WYE-DELTA EUROPEAN

NOTES

1.1 GENERAL

Sullair Corporation and its subsidiaries design and manufacture all of their products so they can be operated safely. However, the responsibility for safe operation rests with those who use and maintain these products. The following safety precautions are offered as a guide which, if conscientiously followed, will minimize the possibility of accidents throughout the useful life of this equipment.

The compressor should be operated only by those who have been trained and delegated to do so, and who have read and understood this Operator's Manual. Failure to follow the instructions, procedures and safety precautions in this manual can result in accidents and injuries. Read this manual prior to startup.

NEVER start the compressor unless it is safe to do so. **DO NOT** attempt to operate the compressor with a known unsafe condition. Tag the compressor and render it inoperative by disconnecting and locking out all power at source or otherwise disabling its prime mover, so others who may not know of the unsafe condition, cannot attempt to operate it until the condition is corrected.

Install, use and operate the compressor only in full compliance with all pertinent regulations and all applicable Federal, State, and Local codes, standards and regulations.

DO NOT modify the compressor and/or controls in any way except with written factory approval.

While not specifically applicable to all types of compressors with all types of prime movers, most of the precautionary statements contained herein are applicable to most compressors and the concepts behind these statements are generally applicable to all compressors.

1.2 PERSONAL PROTECTIVE EQUIPMENT

Prior to installing or operating the compressor, owners, employers and users should become familiar with, and comply with, all applicable regulations and any applicable Federal, State and Local codes, standards, and regulations relative to personal protective equipment, such as eye and face protective equipment, respiratory protective equipment, equipment intended to protect the extremities, protective clothing, protective shields and barriers and electrical protective equipment, as well as noise exposure administrative and/or engineering controls and/or personal hearing protective equipment.

1.3 PRESSURE RELEASE

A. Install an appropriate flow-limiting valve between the service air outlet and the shut-off (throttle) valve, either at the compressor or at any other point along the air line, when an air hose exceeding 1/2" (13mm) inside diameter is to be connected to the shut-off (throttle) valve, to reduce pressure in case of hose

failure, per all applicable Federal, State and Local codes, standards and regulations.

B. When the hose is to be used to supply a manifold, install an additional appropriate flow-limiting valve between the manifold and each air hose exceeding 1/2" (13mm) inside diameter that is to be connected to the manifold to reduce pressure in case of hose failure.

C. Provide an appropriate flow-limiting valve at the beginning of each additional 75 feet (23m) of hose in runs of air hose exceeding 1/2" (13mm) inside diameter to reduce pressure in case of hose failure.

D. Flow-limiting valves are listed by pipe size and rated CFM. Select appropriate valves accordingly, in accordance with their manufacturer's recommendations.

E. DO NOT use air tools that are rated below the maximum rating of the compressor. Select air tools, air hoses, pipes, valves, filters, and other fittings accordingly. **DO NOT** exceed manufacturer's rated safe operating pressures for these items.

F. Secure all hose connections by wire, chain or other suitable retaining devices to prevent tools or hose ends from being accidentally disconnected and expelled.

G. Open fluid filler cap only when compressor is **not running and is not pressurized**. Shut down the compressor and bleed the sump (receiver) to zero internal pressure before removing the cap.

H. Vent all internal pressure prior to opening any line, fitting, hose, valve, drain plug, connection or other component, such as filters and line oilers, and before attempting to refill optional air line anti-icer systems with antifreeze compound.

I. Keep personnel out of line with and away from the discharge opening of hoses or tools or other points of compressed air discharge.

J. Use air at pressures less than 30 psig (2.1 bar) for cleaning purposes, and then only with effective chip guarding and personal protective equipment.

K. DO NOT engage in horseplay with air hoses as death or serious injury may result.

L. DO NOT tamper with sump and unit (if provided) relief valves. Check the relief valve as recommended in the Maintenance Section of this manual or at a minimum of at least weekly to make sure it is not blocked, clogged, obstructed or otherwise disabled. **DO NOT** change the factory setting of the relief valve.

M. If the compressor is installed in an enclosed area, it is necessary to vent the relief valve to the outside of the structure or to an area of non-exposure.

Section 1 SAFETY

1.4 FIRE AND EXPLOSION

⚠ WARNING

When installing a Base Load Transfer (BLT) System, remove jumpers between 16-17 & 18-19 (Dual Control Compressors) so the other compressor does not backfeed defeating the shutdown circuitry.

- A.** Clean up spills of lubricant or other combustible substances immediately, if such spills occur.
- B.** Shut off the compressor and allow it to cool. Then keep sparks, flames and other sources of ignition away and **DO NOT** permit smoking in the vicinity when checking or adding lubricant or when refilling air line anti-icer systems with antifreeze compound.
- C. DO NOT** permit fluids, including air line anti-icer system antifreeze compound or fluid film to accumulate on, under, or around acoustical material, or on any external surfaces of the air compressor or on internal surfaces of the enclosure. Wipe down using an aqueous industrial cleaner or steam-clean as required. If necessary, remove acoustical material, clean all surfaces and then replace acoustical material. Any acoustical material with a protective covering that has been torn or punctured should be replaced immediately to prevent accumulation of liquids or fluid film within the material. **DO NOT** use flammable solvents for cleaning purposes.
- D.** Disconnect and lock out all power at source prior to attempting any repairs or cleaning of the compressor or of the inside of the enclosure, if any.
- E.** Keep electrical wiring, including all terminals and pressure connectors in good condition. Replace any wiring that has cracked, cut abraded or otherwise degraded insulation, or terminals that are worn, discolored or corroded. Keep all terminals and pressure connectors clean and tight.
- F.** Keep grounded and/or conductive objects such as tools away from exposed live electrical parts such as terminals to avoid arcing which might serve as a source of ignition.
- G.** Remove any acoustical material or other material that may be damaged by heat or that may support combustion and is in close proximity, prior to attempting weld repairs.
- H.** Keep suitable fully charged fire extinguisher or extinguishers nearby when servicing and operating the compressor.
- I.** Keep oily rags, trash, leaves, litter or other combustibles out of and away from the compressor.
- J. DO NOT** operate the compressor without proper flow of cooling air or water or with inadequate flow of lubricant or with degraded lubricant.

K. DO NOT attempt to operate the compressor in any classification of hazardous environment unless the compressor has been specially designed and manufactured for that duty.

1.5 MOVING PARTS

- A.** Keep hands, arms and other parts of the body and also clothing away from couplings, fans and other moving parts.
- B. DO NOT** attempt to operate the compressor with the fan, coupling or other guards removed.
- C.** Wear snug-fitting clothing and confine long hair when working around this compressor, especially when exposed to hot or moving parts.
- D.** Keep access doors, if any, closed except when making repairs or adjustments.
- E.** Make sure all personnel are out of and/or clear of the compressor prior to attempting to start or operate it.
- F.** Disconnect and lock out all power at source and verify at the compressor that all circuits are de-energized to minimize the possibility of accidental start-up or operation, prior to attempting repairs or adjustments. This is especially important when compressors are remotely controlled.
- G.** Keep hands, feet, floors, controls and walking surfaces clean and free of fluid, water, or other liquids to minimize the possibility of slips and falls.

1.6 HOT SURFACES, SHARP EDGES AND SHARP CORNERS

- A.** Avoid bodily contact with hot fluid, hot coolant, hot surfaces and sharp edges and corners.
- B.** Keep all parts of the body away from all points of air discharge.
- C.** Wear personal protective equipment including gloves and head covering when working in, on or around the compressor.
- D.** Keep a first aid kit handy. Seek medical assistance promptly in case of injury. **DO NOT** ignore small cuts and burns as they may lead to infection.

1.7 TOXIC AND IRRITATING SUBSTANCES

- A. DO NOT** use air from this compressor for respiration (breathing) except in full compliance with any Federal, State or Local Codes or regulations.

⚠ DANGER

Death or serious injury can result from inhaling compressed air without using proper safety equipment.

- B. DO NOT** use air line anti-icer systems in air lines supplying respirators or other breathing air utilization equipment and **DO NOT** discharge air from these systems in unventilated or other confined areas.

C. Operate the compressor only in open or adequately ventilated areas.

D. Locate the compressor or provide a remote inlet so that it is not likely to ingest exhaust fumes or other toxic, noxious or corrosive fumes or substances.

E. Coolants and lubricants used in this compressor are typical of the industry. Care should be taken to avoid accidental ingestion and/or skin contact. In the event of ingestion, seek medical treatment promptly. Wash with soap and water in the event of skin contact. Consult the compressor operator's manual lubrication section for information pertaining to compressor fluid fill.

F. Wear goggles or a full face shield when adding antifreeze compound to air line anti-icer systems.

G. If air line anti-icer system antifreeze compound enters the eyes or if fumes irritate the eyes, they should be washed with large quantities of clean water for 15 minutes. A physician, preferably an eye specialist, should be contacted immediately.

H. DO NOT store air line anti-icer system antifreeze compound in confined areas.

I. The antifreeze compound used in air line anti-freeze systems contains methanol and is toxic, harmful, or fatal if swallowed. Avoid contact with the skin or eyes and avoid breathing the fumes. If swallowed, induce vomiting by administering a tablespoon of salt, in each glass of clean, warm water until vomit is clear, then administer two teaspoons of baking soda in a glass of clean water. Have patient lay down and cover eyes to exclude light. Call a physician immediately.

1.8 ELECTRICAL SHOCK

A. This compressor should be installed and maintained in full compliance with all applicable Federal, State and Local codes, standards and regulations, including those of the National Electrical Code, and also including those relative to equipment grounding conductors, and only by personnel that are trained, qualified and delegated to do so.

B. Keep all parts of the body and any hand-held tools or other conductive objects away from exposed live parts of electrical system. Maintain dry footing, stand on insulating surfaces and **DO NOT** contact any other portion of the compressor when making adjustments or repairs to exposed live parts of the electrical system. Make all such adjustments or repairs with one hand only, so as to minimize the possibility of creating a current path through the heart.

C. Attempt repairs in clean, dry and well lighted and ventilated areas only.

D. DO NOT leave the compressor unattended with open electrical enclosures. If necessary to do so, then disconnect, lock out and tag all power at source so others will not inadvertently restore power.

E. Disconnect, lock out, and tag all power at source prior to attempting repairs or adjustments to rotating machinery and prior to handling any ungrounded conductors.

F. Dry test all shutdown circuits prior to starting the compressor after installation.

1.9 LIFTING

A. If the compressor is provided with a lifting bail, then lift by the bail provided. If no bail is provided, then lift by sling. Compressors to be air lifted by helicopter must not be supported by the lifting bail but by slings instead. In any event, lift and/or handle only in full compliance with Federal, State and Local codes.

B. Inspect points of attachment for cracked welds and for cracked, bent, corroded or otherwise degraded members and for loose bolts or nuts prior to lifting.

C. Make sure entire lifting, rigging and supporting structure has been inspected, is in good condition and has a rated capacity of at least the weight of the compressor. If you are unsure of the weight, then weigh compressor before lifting.

D. Make sure lifting hook has a functional safety latch or equivalent, and is fully engaged and latched on the bail or slings.

E. Use guide ropes or equivalent to prevent twisting or swinging of the compressor once it has been lifted clear of the ground.

F. DO NOT attempt to lift in high winds.

G. Keep all personnel out from under and away from the compressor whenever it is suspended.

H. Lift compressor no higher than necessary.

I. Keep lift operator in constant attendance whenever compressor is suspended.

J. Set compressor down only on a level surface capable of safely supporting at least its weight and its loading unit.

K. When moving compressors by forklift truck, utilize fork pockets if provided. Otherwise, utilize pallet if provided. If neither fork pockets or pallet are provided, then make sure compressor is secure and well balanced on forks before attempting to raise or transport it any significant distance.

L. Make sure forklift truck forks are fully engaged and tipped back prior to lifting or transporting the compressor.

M. Forklift no higher than necessary to clear obstacles at floor level and transport and corner at minimum practical speeds.

N. Make sure pallet-mounted compressors are firmly bolted or otherwise secured to the pallet prior to attempting to forklift or transport them. **NEVER** attempt to forklift a compressor that is not secured to its pallet, as uneven floors or sudden stops may cause the compressor to tumble off, possibly causing serious injury or property damage in the process.

Section 1

SAFETY

O. DO NOT use the lifting eye bolt on the compressor motor, if supplied, to lift the entire compressor package.

1.10 ENTRAPMENT

A. If the compressor enclosure is large enough to hold a person and if it is necessary to enter it to perform service adjustments, inform other personnel

before doing so, or else secure and tag the access door in the open position to avoid the possibility of others closing and possibly latching the door with personnel inside.

B. Make sure all personnel are out of compressor before closing and latching enclosure doors.

2.1 LOCATION OF COMPRESSOR

The ES-8 Series compressor package may be placed on any level surface able to support its weight. The unit is mounted on vibration mounts and can be bolted to a fixed mounting surface to avoid the possibility of externally applied forces or vibration which would disturb the piping or wiring.

2.2 VENTILATION AND COOLING

Select a location to permit sufficient unobstructed air flow in and out of the compressor to keep the operating temperature stable. The minimum distance that the machine should be from surrounding walls and ceiling is what is needed for service and three (3) feet (0.91m) or more from the compressor fluid cooler.

2.3 SERVICE AIR PIPING

Service air piping should be installed as shown in Figure 2-1. A shut-off valve should be installed to isolate the compressor from the service line. Also notice that the service line should be equipped with water legs and condensate drains throughout the system.

⚠ WARNING

“The Plastic Pipe Institute recommends against the use of thermoplastic pipe to transport compressed air or other compressed gases in exposed above ground locations, e.g. in exposed plant piping.” (I)

Sullube should not be used with PVC piping systems. It may affect the bond at cemented joints. Certain other plastic materials may also be affected.

(I) Plastic Pipe Institute, Recommendation B, Adopted January 19, 1972.

2.4 COUPLING ALIGNMENT CHECK

With the compressor unit directly flange-mounted to

its drive, the coupling supplied with the compressor is always properly aligned for operation. However, we recommend that you re-check the coupling gap before start-up or when handling the unit. A 1.5 to 3mm axial clearance should be maintained for the coupling gap.

2.5 FLUID LEVEL CHECK

The Sullair air compressor is equipped with the proper amount of fluid. However, it is necessary to check the fluid level at installation. The level is checked by looking at the fluid level sight tube located on the end bell.

If the sump is properly filled, the fluid level should cover 1/4 to 1/2 of the level range during operation. With the compressor shut down, the level should be 3/4 of the sight tube. **DO NOT** overfill.

2.6 MOTOR ROTATION DIRECTION CHECK

After the electrical wiring has been done, it is necessary to check the direction of the motor rotation.

Pull out the **EMERGENCY STOP** button and press once, quickly and in succession, the **(START) I** and **(STOP) O** pads. This action will bump start the motor for a very short time. When looking at the motor from the control panel side, view the coupling by looking through the air inlet duct on the lower side of the adapter fan housing. The coupling should be turning clockwise. If the reversed rotation is noted, disconnect the power to the starter and exchange any two of the three power input leads, then re-check rotation. A “Direction of Rotation” decal is located on the motor and cooler shroud to show proper motor/compressor rotation.

2.7 ELECTRICAL PREPARATION

Interior electrical wiring is performed at the factory. Required customer wiring is minimal, but should be done by a qualified electrician in compliance with

Figure 2-1 Service Air Piping

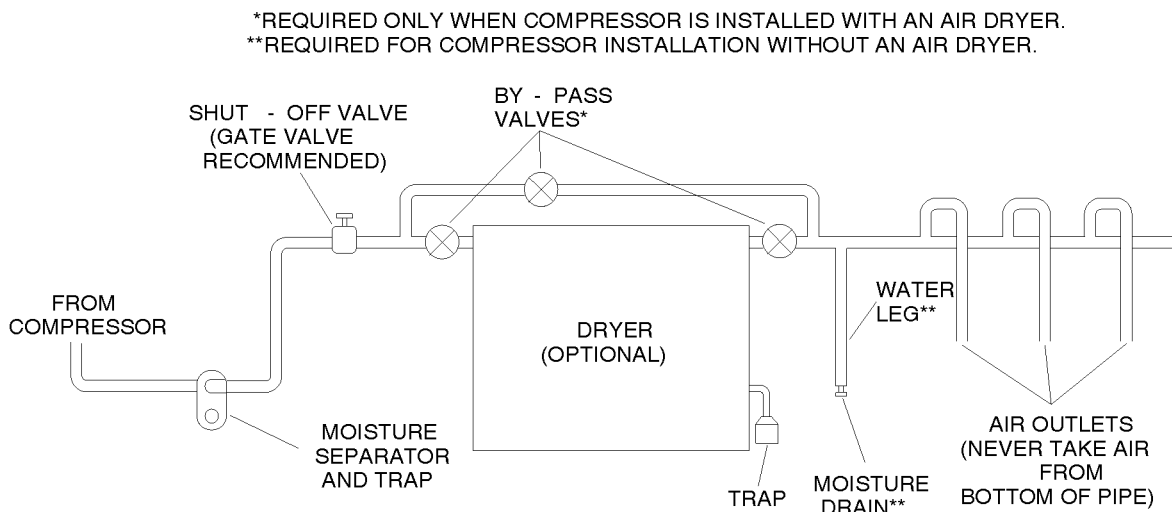

Section 2

INSTALLATION

OSHA, National Electrical Code, and/or any other applicable State, Federal and local electrical codes concerning isolation switches, fused disconnects, etc. Sullair provides a wiring diagram for use by the installer.

NOTE

Customer must provide electrical supply power disconnect within sight of machine.

A few electrical checks should be made to help assure that the first start-up will be trouble-free.

⚠ WARNING

Lethal shock hazard inside. Disconnect all power at source before opening or servicing.

1. Check incoming voltage. Be sure that compressor is wired for the correct incoming voltage.
2. Check starter for correct size, proper overload relay, and heaters.
3. Check all electrical connections for tightness.
4. "DRY RUN" the electrical controls by disconnecting the three (3) motor leads from the starter. Pull out the EMERGENCY STOP button on the control panel.
5. Reconnect the motor leads and jog the motor for a direction of rotation check as explained in [Section 2.6](#).

NOTE

Wiring diagram for standard compressors is supplied on the inside cover of the Control Center. Optional compressor wiring diagrams will vary.

3.1 SPECIFICATIONS- ES-8

50 Hz MODEL	KW	M³/MIN	BAR	LENGTH (MM) OPEN[ENCL]	WIDTH (MM) OPEN[ENCL]	HEIGHT (MM) OPEN[ENCL]	WEIGHT (KG) OPEN[ENCL]	dBA (I) w/ Encls./ w/o Encls.
15L	11	1.62	6.9	1239 [1524]	852 [914]	763 [1067]	424 [483]	70/80
15HH	11	1.34	9.7	1239 [1524]	852 [914]	763 [1067]	424 [483]	70/80
15XH	11	1.02	12.1	1239 [1524]	852 [914]	763 [1067]	424 [483]	70/80
20L	15	2.29	6.9	1283 [1524]	852 [914]	763 [1067]	455 [513]	73/83
20HH	15	1.84	9.7	1283 [1524]	852 [914]	763 [1067]	455 [513]	73/83
20XH	15	1.50	12.1	1283 [1524]	852 [914]	763 [1067]	455 [513]	73/83
25L	18.5	2.77	6.9	1283 [1524]	852 [914]	763 [1067]	480 [537]	75/85
25HH	18.5	2.18	9.7	1283 [1524]	852 [914]	763 [1067]	480 [537]	75/85
25XH	18.5	1.78	12.1	1283 [1524]	852 [914]	763 [1067]	480 [537]	75/85
30L	22	3.25	6.9	1291 [1524]	852 [914]	763 [1067]	483 [542]	76/85
30HH	22	2.72	9.7	1291 [1524]	852 [914]	763 [1067]	483 [542]	76/85
30XH	22	2.12	12.1	1291 [1524]	852 [914]	763 [1067]	483 [542]	76/85

60 Hz MODEL	HP	ACFM	PSIG	LENGTH (IN.) OPEN[ENCL]	WIDTH (IN.) OPEN[ENCL]	HEIGHT (IN.) OPEN[ENCL]	WEIGHT (LBS.) OPEN[ENCL]4	dBA (I) w/ Encls./ w/o Encls.
15L	15	65	100	49 [60]	34 [42]	30 [36]	935 [1065]	70/80
15HH	15	57	125	49 [60]	34 [42]	30 [36]	935 [1065]	70/80
15XH	15	41	175	49 [60]	34 [42]	30 [36]	935 [1065]	70/80
20H	20	76	125	51 [60]	34 [42]	30 [36]	1002 [1132]	73/83
20XH	20	55	175	51 [60]	34 [42]	30 [36]	1002 [1132]	73/83
25H	25	94	125	51 [60]	34 [42]	30 [36]	1055 [1185]	77/85
25XH	25	75	175	51 [60]	34 [42]	30 [36]	1055 [1185]	77/85
30H	30	111	125	51 [60]	34 [42]	30 [36]	1065 [1195]	78/85
30XH	30	90	175	51 [60]	34 [42]	30 [36]	1065 [1195]	78/85

(I) Ratings for dBA at one meter.

COMPRESSOR

Type:	Single Stage Fluid Injected Screw Compressor
Minimum Full Load Operating Pressure:	60 psig (4.2 bar)
Maximum Full Load Operating Pressure:	Nameplate Pressure (I)
Bearing Type:	Anti-friction
Cooling:	Pressurized Fluid
Lubricant:	See Lubricant Specification
Sump Capacity:	2.5 gallons (9.46 liters)

(I) Compressors are available for full load pressures up to 175 psig (12.1 bar), and unload pressure 185 psig (12.8 bar).

MOTOR

	60Hz	50Hz
Type:	ODP, C-Flange	ODP, C-Flange
Synchronous Speed:	15 & 20 HP = 1800 RPM 25 & 30 HP = 3600 RPM	11KW = 1800 RPM 18.5KW = 3600 RPM
Voltage:		
Standard All Sizes:	230/460	380/415
Optional All Sizes:	208	
Optional All Sizes:	575	
Optional Only:		
Type:		
Insulation Class:	B-(Min.)	B-(Min.)
Maximum Ambient Temp.:	40°C (104°F)	40°C (104°F)

Section 3

SPECIFICATIONS

FLUID FILTER

Type:
 Micron:
 Internal Bypass Valve Set at 25 psig (1.7 bar)

Spin on, Sullair Proprietary
 23 Microns Abs.

FLUID SEPARATOR ELEMENT

Type:
 Efficiency at Maximum Capacity:

Push In Cartridge, Sullair Proprietary
 5PPM Maximum

3.2 LUBRICATION GUIDE

For best value and longest uninterrupted service, the ES-8 compressor is factory filled and tested with a long life lubricant.

If, due to availability or other reasons, other fluids are required, follow Lubrication Guide below.

⚠ WARNING

“The Plastic Pipe Institute recommends against the use of thermoplastic pipe to transport compressed air or other compressed gases in exposed above ground locations, e.g. in exposed plant piping.” (I)

Sullube should not be used with PVC piping systems. It may affect the bond at cemented joints. Certain other plastic materials may also be affected.

(I) Plastic Pipe Institute, Recommendation B, Adopted January 19, 1972.

Maintenance of all other components is still recommended as indicated in the Operator’s Manual.

For light-duty high-humidity service where condensed moisture and emulsification (mayonnaise)

may occur, the fluid change interval must be reduced to 300 hours maximum. A non-detergent fluid with rust, oxidation and foam inhibitors and good water separation characteristics should be used.

⚠ WARNING

Mixing of other lubricants within the compressor unit will void all warranties. DO NOT mix fluids.

Contamination of non-detergent mineral fluids with traces of ATF or detergent motor fluids may lead to operational problems such as foaming, filter plugging, orifice or line plugging.

NOTE

Flush system when switching lubricant brands.

When ambient conditions exceed those noted or if conditions warrant use of “extended” life lubricants contact Sullair for recommendation.

Sullair encourages the user to participate in a fluid analysis program. This could result in a fluid change interval that is different from those stated in this manual.

3.3 LUBRICATION CHANGE RECOMMENDATIONS

Table 1- Compressor Lubrication Guide and Maintenance

AMBIENT TEMPERATURE	LUBRICATION	FLUID & FILTER CHANGE PERIOD (HRS.)	SEPARATOR CHANGE PERIOD (HRS.)	AIR FILTER CHANGE PERIOD (HRS.)
-10°F to +90°F (-23°C to +32°C)	Sullube	8000 (I)	8000 (I)	4000 (II)
	Sullair LLL-4-32	8000 (I)	8000 (I)	4000 (II)
	SRF 1/4000	4000	4000	4000 (II)

(I) 8,000 Hours or once a year.

(II) 4,000 Hours or more frequently if conditions so require.

Section 3 SPECIFICATIONS

Figure 3-1 Identification- Standard Model

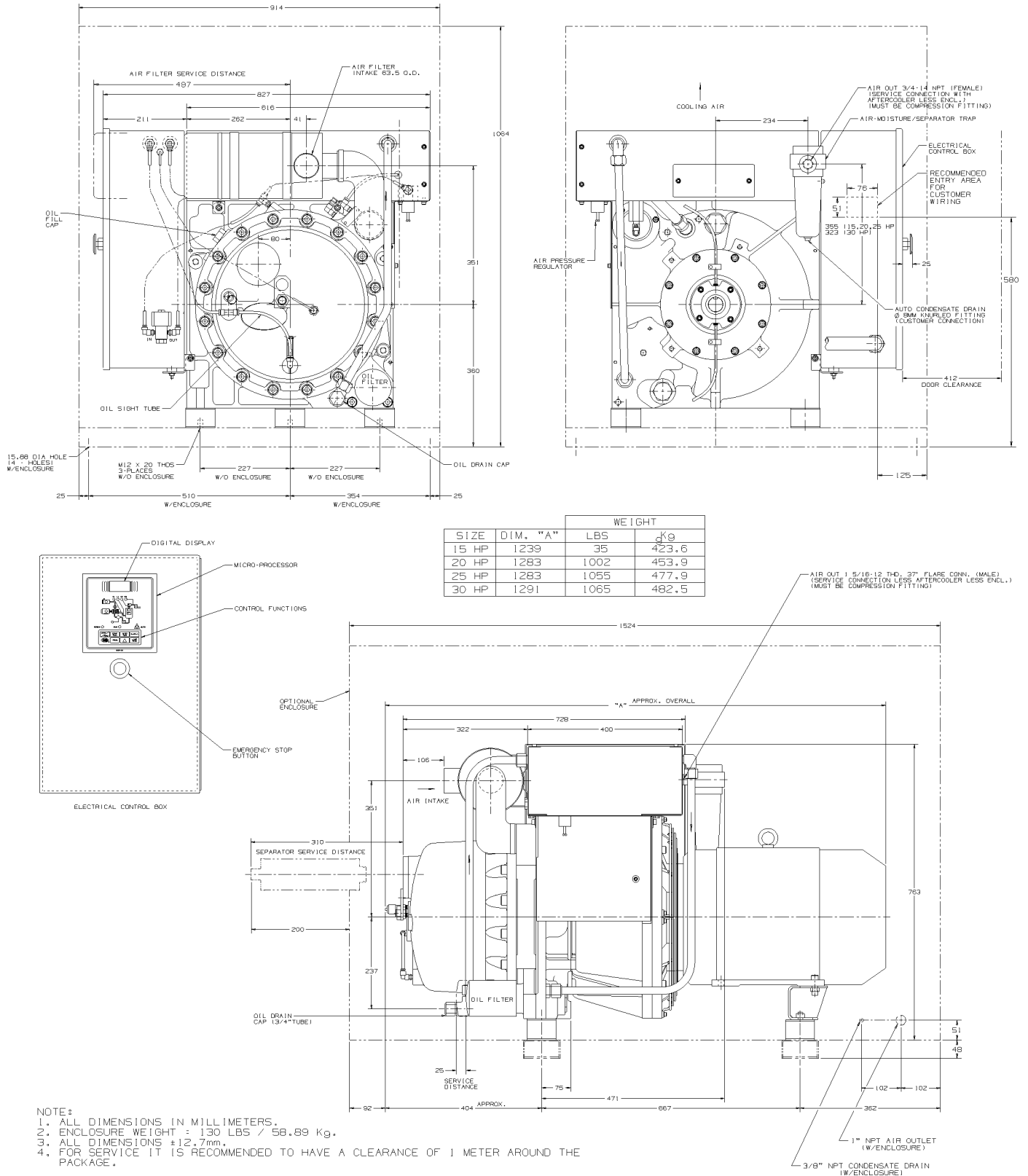

NOTE:
 1. ALL DIMENSIONS IN MILLIMETERS.
 2. ENCLOSURE WEIGHT : 130 LBS / 58.89 Kg.
 3. ALL DIMENSIONS ±12.7mm.
 4. FOR SERVICE IT IS RECOMMENDED TO HAVE A CLEARANCE OF 1 METER AROUND THE PACKAGE.

Section 3 SPECIFICATIONS

Figure 3-2 Identification- Basic Model

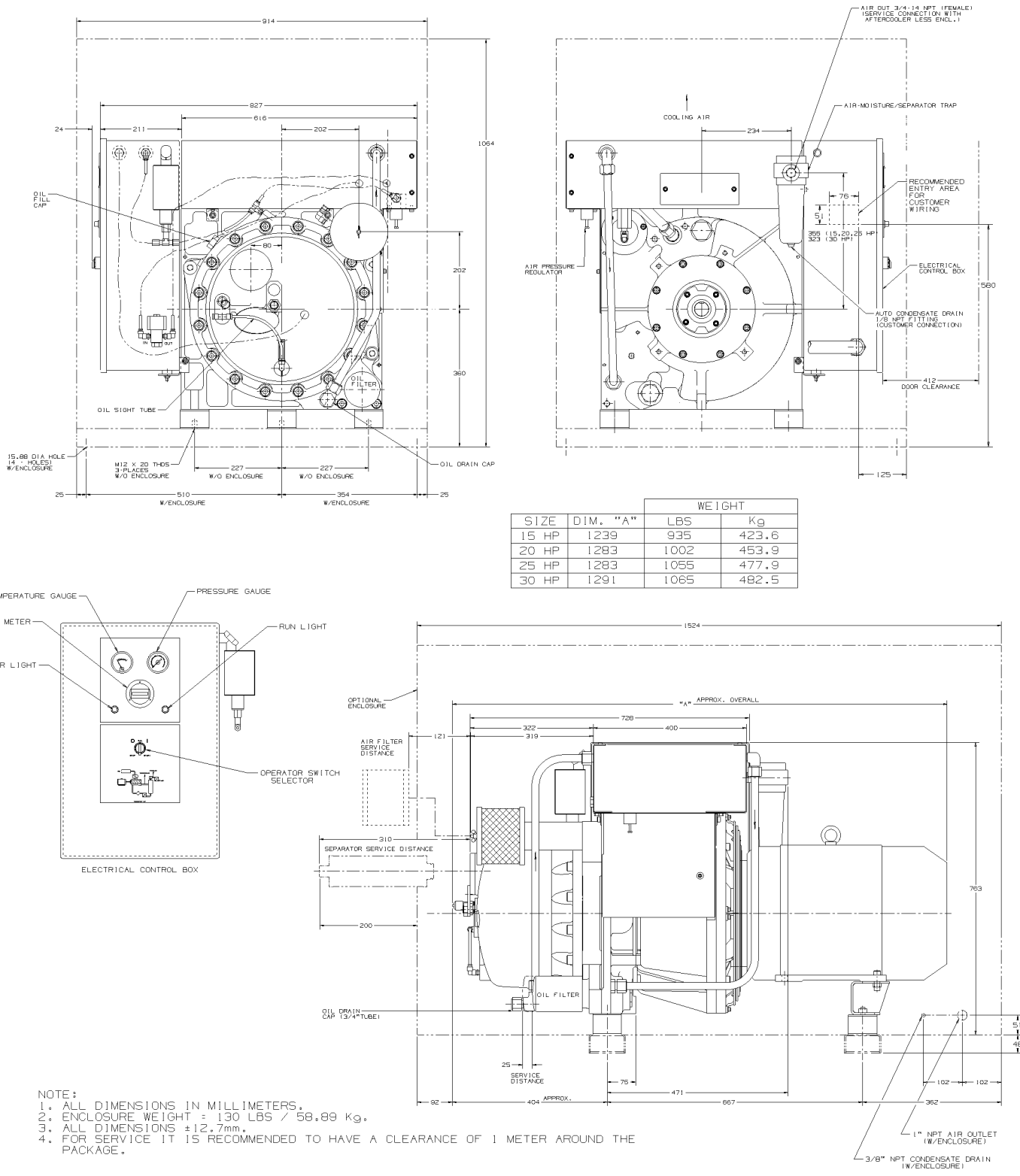

SIZE	DIM. "A"	WEIGHT	
		LBS	Kg
15 HP	1239	935	423.6
20 HP	1283	1002	453.9
25 HP	1283	1055	477.9
30 HP	1291	1065	482.5

NOTE:
 1. ALL DIMENSIONS IN MILLIMETERS.
 2. ENCLOSURE WEIGHT = 130 LBS / 58.89 Kg.
 3. ALL DIMENSIONS ±12.7mm.
 4. FOR SERVICE IT IS RECOMMENDED TO HAVE A CLEARANCE OF 1 METER AROUND THE PACKAGE.

Section 3 SPECIFICATIONS

Figure 3-3 Identification- CIS Model

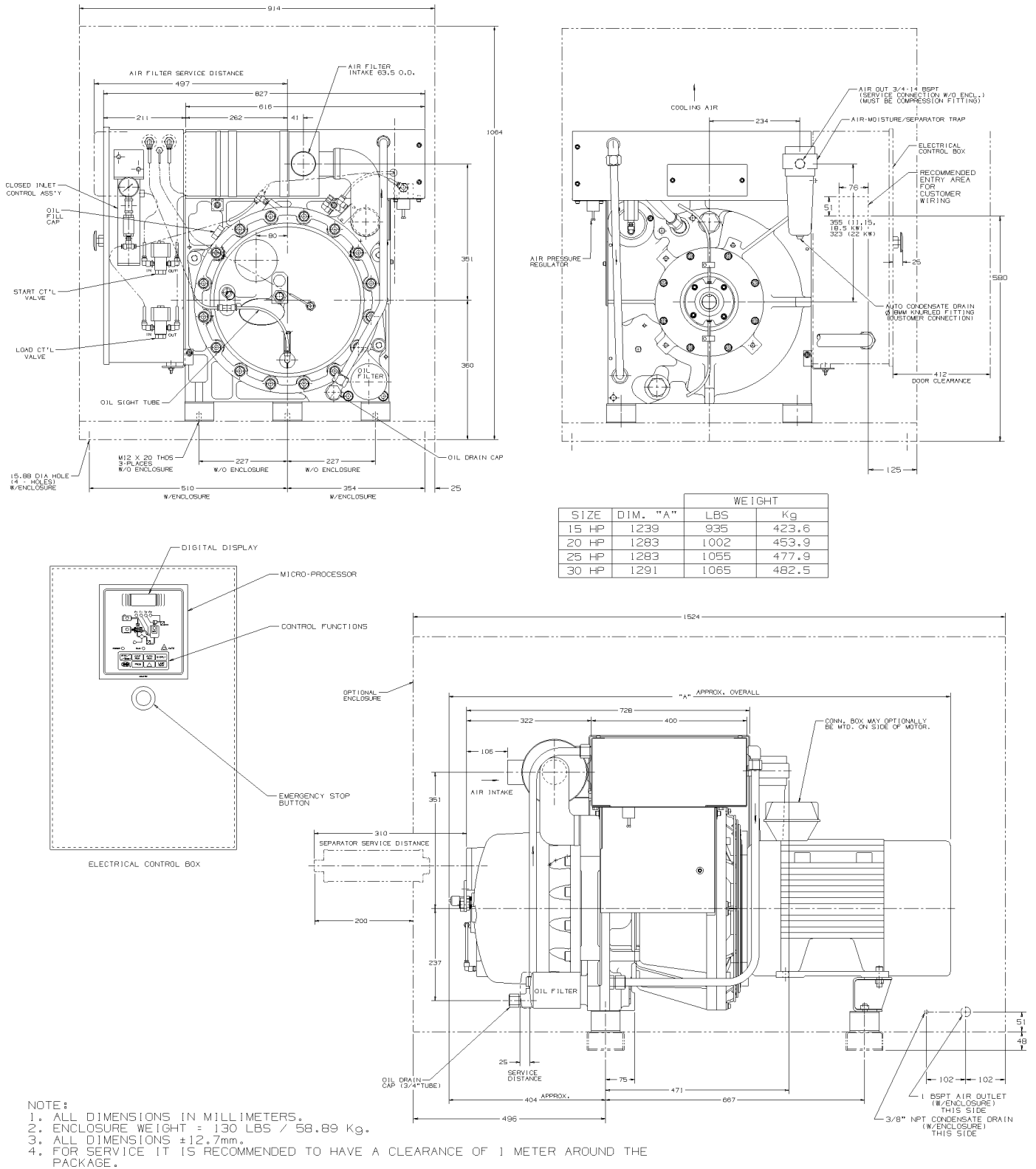

NOTES

4.1 INTRODUCTION

Your new Sullair flood-lubricated rotary screw air compressor will provide you with improved reliability and greatly reduced maintenance.

Compared with other types of compressors, the Sullair rotary screw is unique in mechanical reliability, with “no wear” and “no inspection” required of the working parts within the compressor unit.

Read Section 7 (Maintenance) to keep your compressor in top operating condition. Should any questions arise which cannot be answered in the following text, call your nearest Sullair office or the Sullair Corporation Service Department.

4.2 DESCRIPTION OF COMPONENTS

Refer to Figure 4-1. The components and assemblies of the ES-8 Series air compressor are clearly shown. The complete compressor consists of an **encapsulated compressor system, inlet system, cooling system, control system and supervisor control system.**

The compact design of the ES-8 Series air compressor provides easy access to all serviceable components.

4.3 ENCAPSULATED COMPRESSOR SYSTEM, FUNCTIONAL DESCRIPTION

Refer to Figure 4-2. The encapsulated compressor includes **compressor unit, fluid management system, and drive motor.** The Sullair compressor unit is a single-stage positive displacement lubricated type compressor. This unit is equipped with tapered roller bearings on the discharge and cylindrical roller bearings on the inlet end for high load carrying capacity. This unit provides continuous pulse-free air compression to meet your needs. With a Sullair compressor there will be no maintenance or internal inspection of the compressor.

⚠ WARNING

DO NOT remove caps, plugs and/or other components when compressor is running or pressurized.

Stop compressor and relieve all internal pressure before doing so.

Fluid is injected into the compressor unit in large quantities and mixes directly with the air as the rotors turn, compressing the air. The fluid flow has three main functions:

1. As coolant, it controls the rise of air temperature normally associated with the heat of compression.
2. It seals the leakage paths between the rotors and the stator and also between the rotors themselves.
3. It acts as a lubricating film between the rotors allowing one rotor to directly drive the other, which is an idler.

The air/fluid mixture discharges directly into the fluid management system.

The fluid cooler bypass valve helps assure proper cooling by directing the fluid to the fluid cooler when discharge temperature reaches the thermostat temperature setting.

During start-up in cool ambient conditions, the cooler pressure drop may cause the filter bypass valve to open up, assuring adequate fluid supply to the compressor.

All fluid entering the compressor unit passes through the replaceable fluid filter element. This replaceable filter element contains a built-in bypass valve. Under conditions of restricted flow through the element, the bypass valve helps ensure adequate compressor fluid flow, as well as helps prevent element failure.

FLUID MANAGEMENT SYSTEM

The Fluid Management System consists of a multi-chambered primary/secondary separator, the final air/fluid separator element, cooler bypass and fluid filter.

As compressed air/fluid enters the sump, the first fluid separation takes place due to a reduction of flow speed coupled with a change of direction of the flow within the sump housing. The compressed air reaches the separator and the finest fluid drops and mist are separated.

The minimum pressure/discharge check valve is mounted on the compressor drive housing. Its functions are as follows:

1. Maintains a minimum sump pressure of 60 psig (4.2 bar) under full load operation to help assure adequate fluid pressure.
2. Acts as a check valve to isolate the compressor from the system at shutdown or unload.

DRIVE MOTOR

The Drive Motor consists of a squirrel cage induction motor which is connected to the integrated drive gearing by a drive coupling.

4.4 COMPRESSOR COOLING SYSTEM, FUNCTIONAL DESCRIPTION

The Compressor Cooling System consists of a fluid cooler, fan and cooler shroud.

The fan is mounted on the compressor shaft. Air is drawn through the motor adaptor by the fan and exits through the coolers on top of the compressor. The air provides cooling for compressor fluid and cooling of air on units with air aftercoolers.

4.5 AIR INLET SYSTEM, FUNCTIONAL DESCRIPTION

The compressor inlet system consists of a dry-type air filter and an air control valve. Reacting on a pressure signal, the valve closes the intake for unloaded operation. The valve also acts as a check valve upon shutdown.

Section 4 COMPRESSOR SYSTEMS

Figure 4-1 Description of Components

STANDARD COMPRESSOR

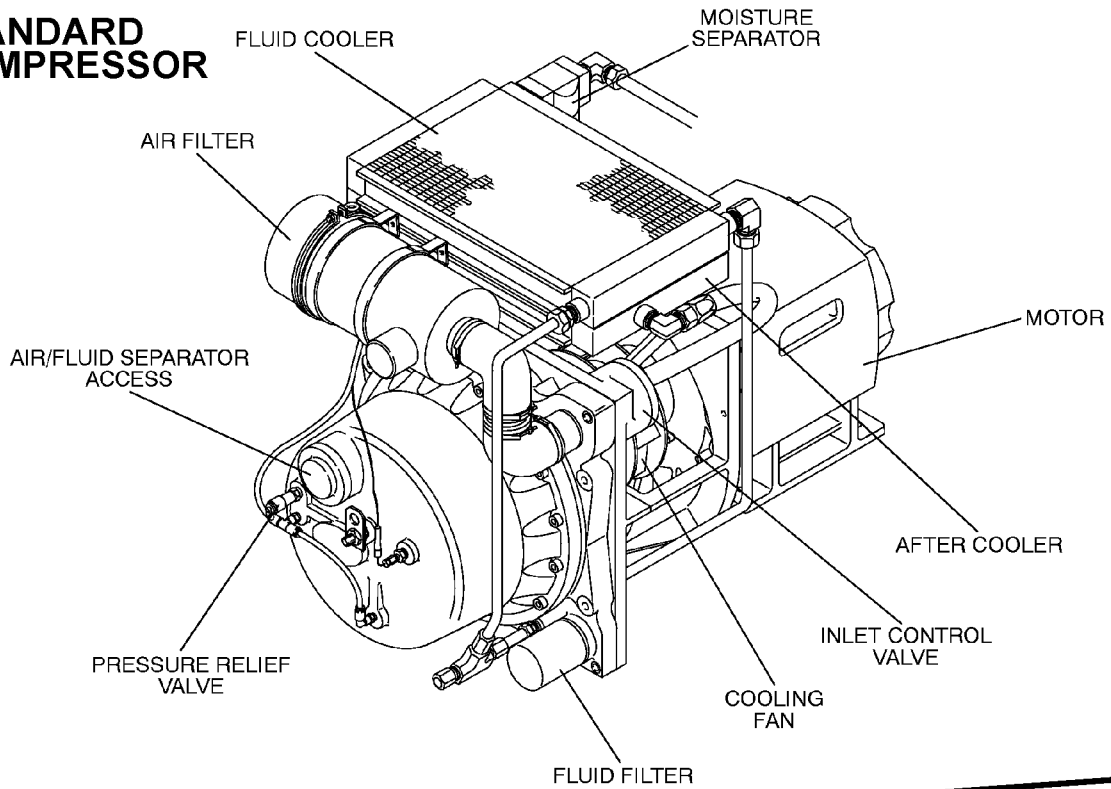

BASIC COMPRESSOR

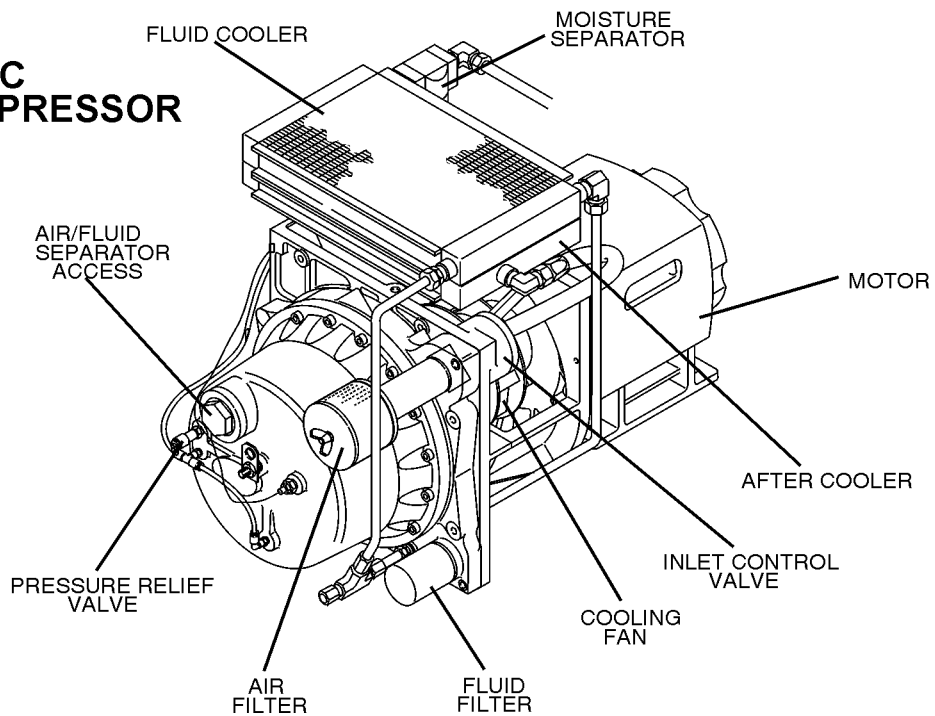
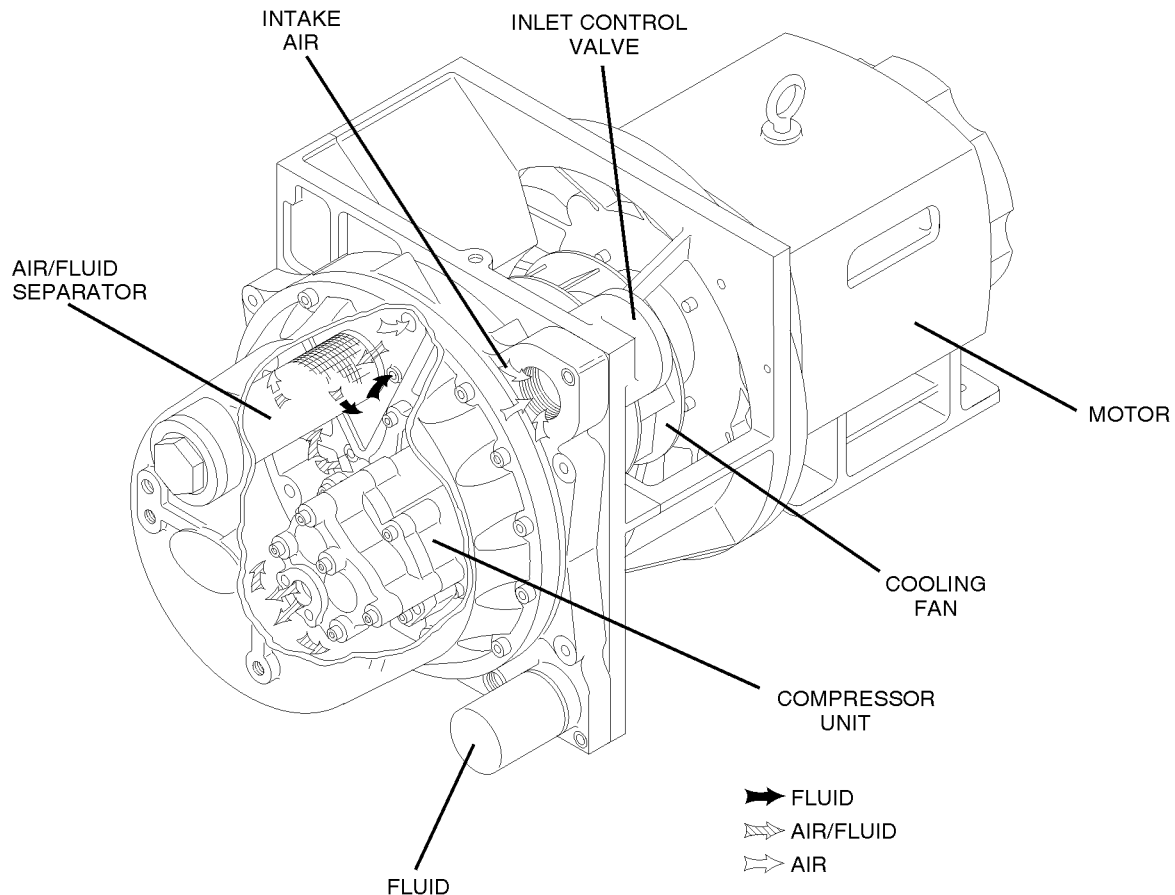

Figure 4-2 Encapsulated Compressor System



4.6 CONTROL SYSTEM, FUNCTIONAL DESCRIPTION

The purpose of the compressor control system is to regulate the amount of air being compressed to match the amount of compressed air being used. The capacity control system consists of a **solenoid valve**, **regulator valve** and an **inlet valve**. The functional description of the control system is described below in 4 distinct phases of operation. The following description text applies to all Series ES-8 compressors. For explanatory purposes, this description will apply to a compressor with an operating range of 100 to 110 psig (6.9 to 7.6 bar). A compressor with any other pressure range would operate in the same manner except stated pressures.

START MODE - 0 TO 60 PSIG (0 TO 4.2 bar)

When the compressor "I" pad is depressed, the sump pressure will quickly rise from 0 to 60 psig (0 - 4.2 bar). During this period, both the pressure regulator and the solenoid valve are closed, the inlet valve is fully open and the compressor pumps at full rated capacity. The rising compressor air pressure is isolated from the service line in this phase by the minimum pressure valve set at approximately 60

psig (4.2 bar).

FULL LOAD MODE - 60 TO 100 PSIG (4.2 TO 6.9 bar)

When the compressed air pressure rises above 60 psig (4.2 bar), the minimum pressure valve opens allowing compressed air to flow into the service line. From this point on, the line air pressure is continually monitored by the Supervisor. The pressure regulator and the solenoid valve remain closed during this phase. The inlet valve is in the fully open position as long as the compressor is running at 100 psig (6.9 bar) or below.

MODULATING MODE - 100 TO 110 PSIG (6.9 TO 7.6 bar)

If less than the rated capacity of compressed air is being used, the service line pressure will rise above 100 psig (6.9 bar). The pressure regulator valve gradually opens, directing air pressure to the inlet control valve, reducing air entering the compressor until it matches the amount of air being used. The control system functions continually in this manner between the limits of 100 to 110 psig (6.9 to 7.6 bar) in response to varying demands from the service line.

COMPRESSOR SYSTEMS

The pressure regulator has an orifice which vents a small amount of air to the atmosphere when the pressure regulator controls the inlet control valve. The orifice also bleeds any accumulated moisture from the pressure regulator.

UNLOAD MODE - IN EXCESS OF 110 PSIG (7.6 bar)

When a relatively small amount or no air is being used, the service line pressure continues to rise. When it exceeds 110 psig (7.6 bar), the Supervisor Control System de-energizes the solenoid valve allowing sump air pressure to be supplied directly to close the inlet valve. Simultaneously, the solenoid valve sends a pneumatic signal to the blowdown valve. The blowdown valve opens the sump to the atmosphere, reducing the sump pressure to approximately 20 to 30 psig (1.4 to 2.1 bar). The check valve in the air service line prevents line pressure from returning to the sump.

When the line pressure drops to the low setting (cut-in pressure; usually 100 psig [6.9 bar] on low pressure ["L"] compressors and 125 psig [8.6 bar] on high pressure ["HH"] compressors, 175 psig [12.1 bar] on ["XH"] compressors), Supervisor energizes the solenoid valve and allows the blowdown valve to close. The re-energized solenoid valve again prevents line pressure from reaching the inlet control valve. Should the pressure begin to rise, the pressure regulator will resume its normal function as previously described.

AUTOMATIC OPERATION

For applications with varied periods of time when there are no air requirements, Supervisor's AUTOMATIC mode allows the compressor to shutdown (time delayed) when no compressed air requirement is present and restart as compressed air is needed.

Figure 5-1 Supervisor II Panel

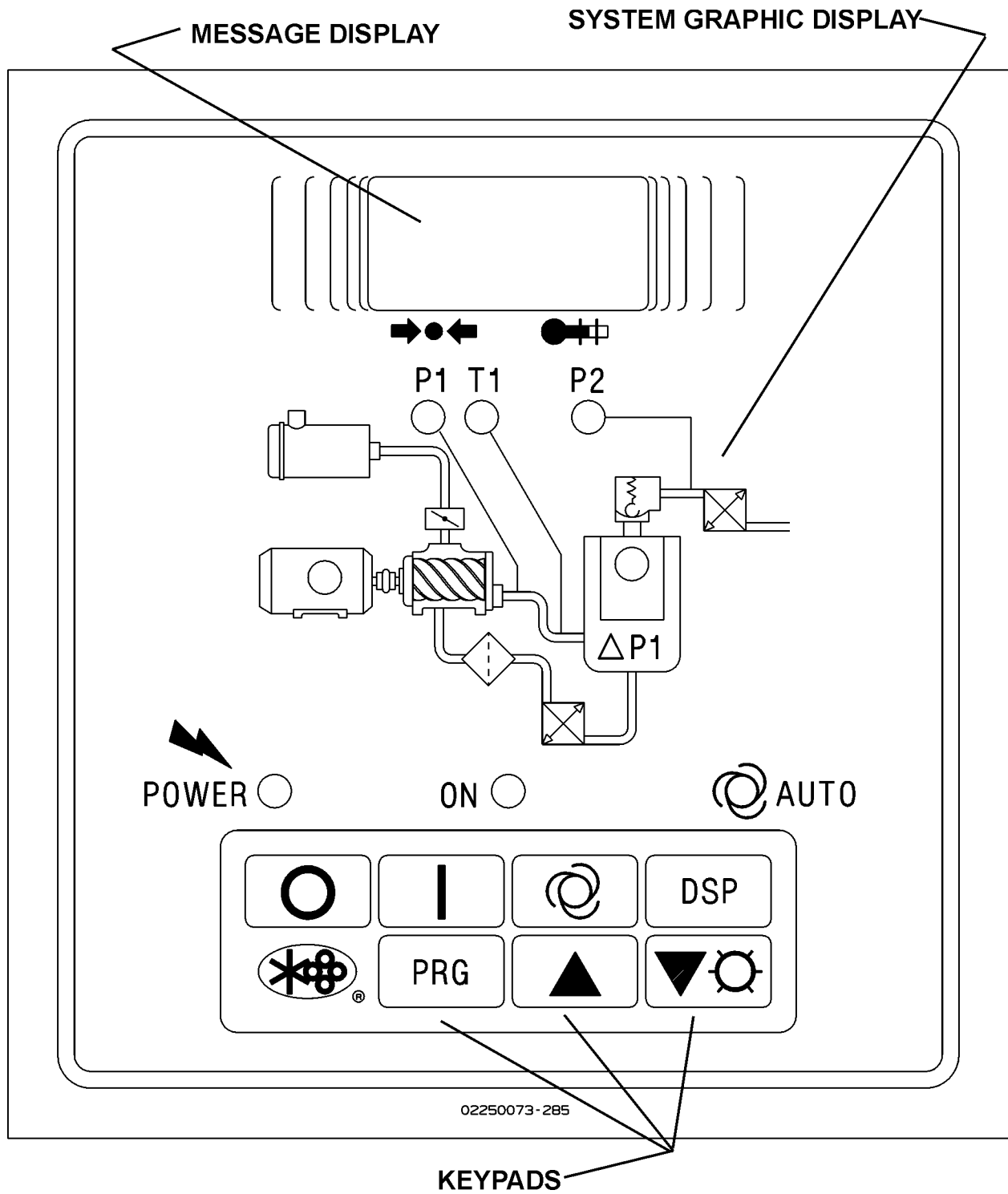

SUPERVISOR II

5.1 INTRODUCTION

Refer to Figure 5-1. The Supervisor II has a two line display to show temperature, pressure and status. It has a keypad for operating the compressor, programming the control points and selecting displays. There is a graphic illustration with lamps that light to show the item being displayed. The lamps flash if that component is in an alarm condition.

5.2 KEYPAD

The keypad is used to control the machine as well as display status and change setpoints. Refer to figure 2-1 for following key descriptions.

- **Stop** - Used to put the machine into manual stop. It is also used to clear alarm conditions.



- **Continuous** - Starts machine if no alarm conditions are present. Also used to clear alarm conditions while machine is running.



- **Auto** - Starts machine and selects auto mode if no alarm conditions are present. Also used to clear alarm conditions while machine is running.



- **Display** - Used to display pressures, temperatures and other status information (See section on STATUS DISPLAYS).



- **Logo** - Used for various functions described in later sections



- **Program** - Used to enter the parameter change mode where control parameters may be displayed and changed (See PARAMETER SETUP).



- **Up arrow** - Used in status displays to

change displays and in parameter setup mode to increment a value.



- **Down arrow, lamp test** - Used in status displays to change displays and in parameter setup mode to increment a value. When in the default display the key will light all the lamps for three seconds.



5.3 STATUS DISPLAYS

By default the line pressure (P2) and discharge temperature (T1) are shown on the bottom line of the display, and machine status on the top line.

The following are the various machine status messages that indicate the state of the compressor with LCD graphics listed below:

- **STOP** - Compressor is off.
- **STANDBY** - Compressor is off but armed to start. This state may be entered because of a power up, or the unload timer had expired and stopped the machine. NOTE : The machine may start at any time.
- **STARTING** - Machine is trying to start.
- **OFF LOAD** - Machine is running and off loaded.
- **ON LOAD** - Machine is running and loaded.
- **FULL LD** - Machine is running and fully loaded. This state is only displayed if the machine has a full load valve.
- **RMT STOP** - Compressor is off but armed to start. The machine will start when the remote start contact is closed. NOTE : the machine may start at any time.
- **SEQ STOP** - Compressor is off but armed to start. The machine will start when the sequencing conditions meet the criteria to start. NOTE : the machine may start at any time.

This default display appears as follows:

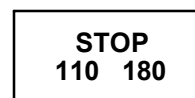

If there are alarms active they will alternately be shown with the default display. The machine status will be displayed for 2 seconds, then the alarms for 2 seconds each. For example:

T1 HI
110 180

To view other status press the DISPLY key. All temperatures and pressures may be displayed as well as other status information. To scroll through the displays press the up arrow or down arrow keys. Up arrow moves to the next display, down arrow the previous display. To return to the default display press the display key.

- Separator differential pressure and the maximum limit. If the limit is exceeded, a separator maintenance warning will be displayed.

dP 1 4
MAX 10

- Sump pressure and line pressure.

P1 113
P2 108

- Unit discharge temperature and the maximum limit. If the temperature exceeds the limit a T1 HI shutdown will occur.

T1 210
MAX 235

- Total hours that the compressor has been running.

HRS RUN
001234.0

- Total hours that the compressor has been loaded.

HRS LOAD
000987.0

- Last fault log. This shows the fault on the first line and the run hours when the fault occurred.

T1 HI
@1 234

- Next to last fault log. This shows the fault on the first line and the run hours when the fault occurred.

T1 HI
@2 204

5.4 LAMP INDICATORS

Embedded into the front panel schematic of the compressor are several lamps. Pressing the lamp test key will light all the lamps for 3 seconds. Each LED lamp has the following purpose.

P1 - If lit steady, signifies that P1 is being displayed, if flashing denotes the presence of an alarm.

P2 - If lit steady, signifies that P2 is being displayed, if flashing denotes the presence of an alarm.

dP1 - If lit steady, signifies that dP1 is being displayed, if flashing denotes replacement of separator is needed.

T1 - If lit steady, signifies that T1 is being displayed, if flashing denotes the presence of an alarm.

MOTOR - If flashing, indicates the motor overload contact has opened.

POWER ON - Lit if 120VAC power is applied to the Supervisor II.

ON - If lit steady, the compressor is running. If flashing, indicates that the compressor is armed but stopped because of restart timer not expired, remote stop or sequence stop. The compressor may start at any time.

AUTO - If lit steady, the compressor is running and in auto mode. If flashing, indicates that the compressor is armed but stopped because of restart timer not expired, remote stop or sequence stop. The compressor may start at any time.

NOTES

COMPRESSOR OPERATION- SUPERVISOR II

6.1 INTRODUCTION

While Sullair has built into this compressor a comprehensive array of controls and indicators to assure you that it is operating properly, you will want to recognize and interpret the reading which will call for service or indicate the beginning of a malfunction. Before starting your Sullair compressor, read this section thoroughly and familiarize yourself with the controls and indicators - their purpose, location and use.

6.2 STANDARD PARAMETER SETUP

Pressing the program key enters parameter display and edit mode. To move to the next parameter press the program key. To increment a parameter press the up arrow key or logo key. The logo key will increment by 10. To decrement the value press the down arrow key.

The parameters are displayed in the following order:

- **Unload pressure** - The pressure where the machine is unloaded. For example if this parameter is set to 110 psi the machine will unload when the line pressure is above 110 psi.

UNLOAD
100 PSI

- **Load differential** - The pressure differential below the unload pressure where the machine is loaded. For example, if the unload pressure is set to 110 and the load differential is set to 10, the machine will load when the line pressure goes below 100 psi.

LOAD
10 PSI

- **P1 Max** - Maximum sump pressure. An alarm and shut down will occur when the sump pressure rises above this pressure.

P1 MAX
135 PSI

- **Wye to delta transition timer** - For full voltage starters this parameter is set to 0.

WYE DELT
10 SEC

- **Restart time** - Time to wait after power up before starting machine. This parameter is used to keep several machines from starting at the same time after power up, or to delay start until other equipment is started. If disabled the machine will not automatical-

ly start after power up.

RST TIME
10 SEC

- **Unload Stop Timer** - If the machine is running in AUTO mode, this parameter specifies the amount of time that the machine will run unloaded before shutting off. If the time is set less than 15 minutes (for example five minutes), there may be times when the machine will run unloaded for more than five minutes. This is because there is another timer that keeps the machine from being started more than four times an hour.

UNLD TIM
15 MIN

- **Language select** - English, German, Spanish, Italian and French may be selected for display language.

LANGUAGE
ENGLISH

- **Units** - English or metric units may be selected.

UNITS
ENGLISH

- **Communications ID #** - This is the network address of a machine. If there is more than one machine connected to the network, each machine must have a unique number.

COM ID #
1

- **Communications baud rate** - This should always be selected to 9600 baud for all sequencing modes. It may be lower for slave or monitoring modes.

BAUDRATE
9600

6.3 SEQUENCING PARAMETERS SETUP

The following parameters are only available on deluxe model Supervisor II.

- **Sequence method** - This parameter sets the method used for sequencing. The choices are DISABLED, REMOTE, SLAVE, HOURS, COM ID#. See the Sequencing & Protocol Manual (See Recom-

COMPRESSOR OPERATION-SUPERVISOR II

mended Spare Parts List) for details about these modes.

**SEQUENCE
HOURS**

- **Drain interval** - The time between actuation of the drain valve.

**DRN INTV
10 MIN**

- **Drain time** - The amount of time that the drain valve is actuated.

**DRN TIM
1 SEC**

- **Last Communication Number** - Used only for sequencing, see Sequencing & Protocol Manual for details.

**LAST COM
3**

- **Lowest Allowable Pressure** - Used only for sequencing, see Sequencing & Protocol Manual for details.

**LOWEST
90 PSI**

- **Recovery Time** - Used only for sequencing, see Sequencing & Protocol Manual for details.

**RECOVER
10 SEC**

- **Rotate Time** - Used only for sequencing, see Sequencing & Protocol Manual for details.

**ROTATE
50**

- **Machine Capacity** - Used only for sequencing, see Sequencing & Protocol Manual for details (not implemented).

**CAPACITY
100**

- **Sequence Hours** - Used only for sequencing, see Sequencing & Protocol Manual for

details.

**SEQ HRS
1000**

6.4 OPERATING THE COMPRESSOR

Before operating the compressor the operating parameters must be setup. See the previous section on operating parameter setup.

MANUAL OPERATION MODE

In this mode the compressor will run indefinitely, as long as temperatures and pressure remain within the valid operating ranges, and the motor overload or emergency stop contacts are not tripped. Pressing the “I” will turn on the compressor and put it in manual mode. If the compressor is already running, but in automatic mode, pressing “I” will switch operation to manual. Pressing “I” while already running in manual mode will cause the Supervisor to turn off the common fault relay, if engaged, and clear any maintenance indicators.

To stop the compressor, press “O” If the compressor is already off when “O” is pressed, the common fault relay will be turned off, if engaged, and it will try to clear the alarm and maintenance indicators. Regardless of what the compressor is doing, pressing “O” puts the Supervisor in manual stop mode.

AUTOMATIC OPERATION MODE

In this mode the compressor will start if line pressure (P2) is less than the **LOAD** parameter. It will stop if the compressor runs unloaded for the number of minutes indicated by the **UNLD TIM** parameter. To put the compressor in automatic mode press “⊙”. If P2 is already less than **LOAD** the compressor will start immediately, otherwise the system status will indicate **STANDBY** and the LED marked **AUTO** will flash.

If the compressor is already running, but in continuous mode, pressing “⊙” will switch operation to automatic. Pressing “⊙” while already running in automatic mode will cause the Supervisor to turn off the common fault relay, if engaged, and clear any maintenance indicators.

In automatic mode the compressor can be stopped manually by pressing “O” Stopping the compressor using “O” will put the Supervisor in manual stop mode.

Regardless of whether in “automatic” or “manual” mode, control of the load solenoid will be based on the parameters **UNLD** and **LOAD**. This operation is as follows:

- P2 > UNLD --> load solenoid turned off**
- P2 < LOAD --> load solenoid turned on**

POWER FAILURE RESTART

If the restart timer (RST TIME parameter) is disabled the compressor will not try to start after a power up. If this time is set to a value the machine will go into standby after power up. When the line pressure drops below the load setpoint, the restart timer will

COMPRESSOR OPERATION- SUPERVISOR II

start timing. When the timer expires the machine will start.

SEQUENCING MODES

The following is a brief description of sequencing modes. For details see the Supervisor II Sequencing & Protocol Manual (See Recommended Spare Parts List).

- **DISABLED** - Responds to status and parameter change messages via the RS485 network but will not respond to start, stop, load or unload messages.

S REMOTE - Responds to status and parameter change messages but will not respond to start, stop, load or unload mes-

sages. The remote inputs and outputs are enabled (start/stop, load/unload, master/local).

- **SLAVE** - Will respond to all messages, but will not start or load unless commanded to do so by a message. This mode is used to control the machine from a master computer.
- **HOURS** - Sends status message about once a second; starts, loads and unloads machines based on sequencing hours.
- **COM ID #** - Sends status message about once a second; starts, loads and unloads machines based on machine Com ID#.

6.5 PURPOSE OF CONTROLS

CONTROL OR INDICATOR	PURPOSE
EMERGENCY STOP SWITCH	Pushing in this switch, found adjacent to the Supervisor, cuts all AC outputs from the latter and de-energizes the starter. A fault message (E STOP) is displayed by the Supervisor until the button is pulled out and the "O" pad is depressed.
MINIMUM PRESSURE/CHECK VALVE	Maintains a minimum of 60 psig (4.2 bar) in compressor sump. Valve piston restricts receiver air discharge from receiver/sump when pressure falls to 60 psig (4.2 bar). Also incorporated in this valve is a terminal check valve which prevents line pressure backflow into the sump during unload conditions and after shutdown.
DISCHARGE TEMPERATURE PROBE	Shuts the compressor down when the compressor discharge temperature exceeds 235°F (113°C). Continually monitors discharge temperature of the compressor.
PRESSURE RELIEF VALVE	Opens sump pressure to the atmosphere if pressure inside the sump become too high. Operation of this valve indicates that the pressure regulator is either faulty or out of adjustment and that the Supervisor II Controller is not offloading due to improper setting or malfunctioning transducers.
SOLENOID VALVE	Closes the inlet valve and activates blowdown valve to vent sump pressure to the atmosphere during unload conditions and shutdowns.
PRESSURE REGULATOR	Controls the intake valve position to control compressor output. The regulator stays closed up to a preset pressure and then opens to provide a rising control pressure to the inlet control valve as output pressure increases.

COMPRESSOR OPERATION- SUPERVISOR II

6.6 SUPERVISOR OUTPUT RELAYS

RELAY	OPERATION
RUN RELAY (K1)	Contact closure energizes the compressor starter.
*-DELTA (K2)	A timed contact used to provide wye-delta transition time.
UNLOAD/LOAD (K3)	Controls ON LOAD/OFF LOAD operation of the load control solenoid valve.
COMMON FAULT (K4)	May be used to provide remote indication of any pre-alarm, maintenance or fault shutdown condition.
DRAIN VALVE (K5)	Controls a solenoid valve to provide automatic condensate removal.
FULL LOAD/MODULATE (K6)	Used with sequencing feature.

NOTE: All output relays will handle 8 amps at 120/240 VAC.

6.7 INITIAL START-UP PROCEDURE

The following procedure should be used to make the initial start-up of the compressor.

1. Read the preceding pages of this manual thoroughly.
2. Jog motor to check for correct rotation of fan (refer to [Section 2.6](#)).
3. Be sure that all preparations and checks described in the Installation Section have been made.
4. Open the shut-off valve to the service line.
5. Check for possible leaks in piping.
7. Slowly close the shut-off valve to assure proper nameplate pressure unload setting is correct. The compressor will unload at nameplate pressure. If adjustments are necessary, see Control System Adjustments.

7. Observe the operating temperature. If the operating temperature exceeds 200°F (93°C), the cooling system and installation environment should be checked.
8. Open shut-off valve to the service line.
9. Reinspect the compressor for temperature and leaks the following day.

6.8 SUBSEQUENT START-UP PROCEDURE

On subsequent start-ups, check that the proper level is visible in the fluid level sight glass and simply press "I" for manual or "C" for automatic operation. When the compressor is running, observe the various parameter displays.

6.9 SHUTDOWN PROCEDURE

To shut the compressor down, push "O" pad.

Section 7

COMPRESSOR OPERATION- ELECTRO-MECHANICAL

7.1 INTRODUCTION

Refer to Figure 7-1. The instrumentation for the ES-8 Series air compressors consists of a panel group which continually monitors the operating condition of the compressor. The standard panel group has the following gauges: A **discharge temperature gauge**, a **line pressure gauge** and an **hourmeter**.

- The **line(terminal) pressure gauge** is connected to the package discharge port. It continually monitors the air pressure.
- The **discharge temperature gauge/switch** monitors the temperature of the air/fluid mixture discharged from the compressor unit. The normal reading should be approximately 185°F (85°C) with 70°F (21°C) ambient. The switch shuts compressor down above 240°F (116°C) discharge temperature.
- The **hourmeter** records the cumulative hours of operation for the compressor. It is useful for planning and logging service operations. The hourmeter is located in the door of the control box.

While Sullair has built into this compressor a comprehensive array of controls and indicators to assure you that it is operating properly, you will want to recognize and interpret the reading which will call for service or indicate the beginning of a malfunction. Before starting your Sullair compressor, read this section thoroughly and familiarize yourself with the controls and indicators - their purpose, location and

Figure 7-1 Instrument Panel Group

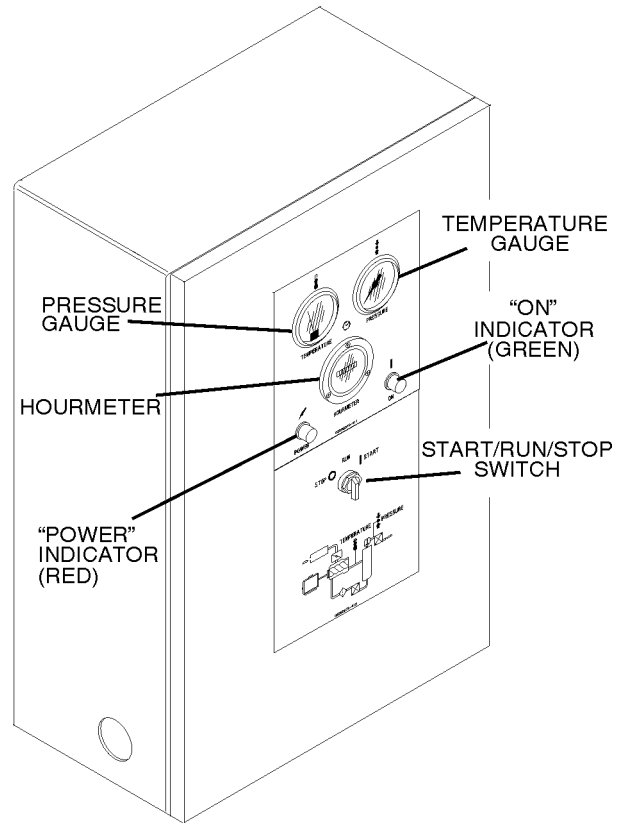

use.

7.2 PURPOSE OF CONTROLS- ELECTRO-MECHANICAL

CONTROL OR INDICATOR	PURPOSE
START/RUN/STOP	<p>START/RUN - Turn switch momentarily to "I" START position to start the compressor, upon release the switch will return to the RUN position.</p> <p>STOP - Turn switch to "O" STOP position to stop compressor.</p>
HOURMETER	Records cumulative hours of compressor operation; useful for planning and logging service schedules.
LINE PRESSURE GAUGE	Continually monitors service line air pressure.
DISCHARGE TEMPERATURE GAUGE/SWITCH	Monitors temperature of the air/fluid mixture discharged from the compressor unit. For air-cooled compressors normal reading is approximately 185°F (85°C) with a 70°F (21°C) ambient temperature. The switch shuts the compressor down when discharge temperature goes above 240°F (116°C).

Section 6

COMPRESSOR OPERATION- ELECTRO-MECHANICAL

7.2 PURPOSE OF CONTROLS- ELECTRO-MECHANICAL (CONTINUED)

CONTROL OR INDICATOR	PURPOSE
PRESSURE REGULATOR	Opens a pressure line between the sump and air inlet valve allowing the inlet valve to regulate air delivery according to demand.
COOLER BYPASS VALVE	Regulates flow of fluid to and around the cooler. Designed to maintain a minimum operating temperature of 180°F (82°C); used for fast warm-up on start-up.
MINIMUM PRESSURE/CHECK VALVE	Maintains minimum of 60 psig (4.1 bar) in the compressor sump. Valve piston restricts receiver air discharge from receiver/sump when pressure falls to 60 psig (4.1 bar). Also incorporated in this valve is a terminal check valve which prevents line pressure backflow into the sump during unload conditions and after shutdown.
PRESSURE RELIEF VALVE	Protects compressor by venting compressed air in excess of 200 psig (13.8 bar) to atmosphere.
MODULATING INLET VALVE	Regulates the amount of air allowed to enter the air compressor. This regulation is determined by the amount of air being used at the service line. Also acts as a check valve to prevent reverse compressor rotation at shut down.
SOLENOID VALVE	Bypasses the pressure regulator valve causing the inlet valve to close when the compressor reaches maximum operating pressure. Also activates blowdown valve.
PRESSURE SWITCH	Senses service line pressure. When line pressure reaches maximum setting the pressure switch signals the solenoid valve to unload the compressor.
BLOWDOWN VALVE	Vents sump pressure to the atmosphere during unload conditions and shutdown.

7.3 INITIAL START-UP PROCEDURE

The following procedure should be used to make the initial start-up of the compressor:

1. Read the preceding pages of this manual thoroughly.
2. Be sure that all preparations and checks described in the Installation section have been made.
3. Crack open the shut off valve to the service line.
4. Start the compressor by turning the START/RUN/STOP selector switch to the "I" (START) position momentarily and release..
5. Check for possible leaks in piping.
6. Slowly close the shut-off valve and check that the setting on the pressure switch is set correctly. If set correctly, the compressor will unload at the desired unload pressure. If adjustments are necessary, see Control System Adjustments in the Maintenance Section of the manual.

7. Observe the operating temperature. If the operating temperature exceeds 200°F (93°C), the cooling system or installation environment should be checked.

8. Observe maintenance indicators.
9. Open shut-off valve to service line.
10. Re-inspect the compressor for temperature and leaks the following day.

7.4 SUBSEQUENT START-UP PROCEDURE

On subsequent start-ups, check that the proper level is visible in the fluid sight glass and turn the START/RUN/STOP selector switch to the "I" START position momentarily and release. When the compressor is running, observe the instrument panel and maintenance indicators.

7.5 SHUTDOWN PROCEDURE

To shut the compressor down, simply turn the selector switch to the "O" STOP position.

8.1 INTRODUCTION

⚠ WARNING

Before doing compressor maintenance, disconnect compressor from power source and lock out power source. Isolate compressor from line pressure by closing recommended discharge shut-off valve and releasing all internal pressure from compressor.

As you proceed in reading this section, it will be easy to see that the maintenance program for the air compressor is quite minimal. The Supervisor monitors the status of the separator element. When maintenance to this device is required, the Supervisor will display the appropriate maintenance message and flash the location LED on the graphics map as a visual reminder. See instructions for each item in Section 8.6, Parts Replacement and Adjustment procedures.

⚠ WARNING

DO NOT remove caps, plugs, and/or other components when compressor is running or pressurized.

Stop compressor and relieve all internal pressure before doing so.

8.2 DAILY OPERATION

Prior to starting the compressor, it is necessary to check the fluid level in the sump. Should the level be low, simply add the necessary amount. If the addition of fluid becomes too frequent, a minor problem has developed which is causing this excessive loss. See the Troubleshooting Section under Excessive Fluid Consumption for a probable cause and remedy.

After a routine start has been made, a general check of the overall compressor should be made to assure that the compressor is running properly.

8.3 MOTOR BEARING LUBRICATION

⚠ WARNING

Before doing compressor maintenance, disconnect compressor from power source and lock out power source. Isolate compressor from line pressure by closing recommended discharge shut-off valve and releasing all internal pressure from compressor.

Figure 8-1 Fluid Filter (P/N 250026-982)

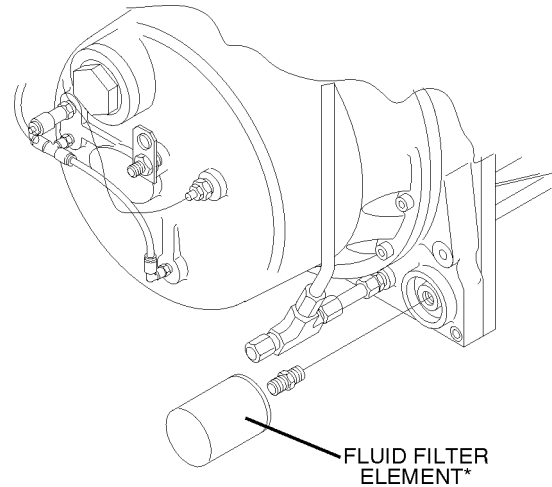

* Replacement Element Kit P/N 02250050-602

See motor manufacturer's lubrication instructions.

8.4 FLUID FILTER MAINTENANCE

⚠ WARNING

Fluid filter has internal bypass. DO NOT SUBSTITUTE.

Refer to figure 8-1 and 8-2. Replace the fluid filter element under any of the following conditions:

1. As recommended in the Lubrication Guide in the Specification Section.
2. Every fluid change.

8.5 COOLER MAINTENANCE

If cooler becomes restricted, use standard spray degreaser/cleaner and brush to clean cooler. Use air pressure to blow cooler clean. Care must be taken as not to damage cooler fins.

⚠ WARNING

Before doing compressor maintenance, disconnect compressor from power source and lock out power source. Isolate compressor from line pressure by closing recommended discharge shut-off valve and releasing all internal pressure from compressor.

Table 1- Compressor Lubrication Guide and Maintenance

AMBIENT TEMPERATURE	LUBRICATION	FLUID & FILTER CHANGE PERIOD (HRS.)	SEPARATOR CHANGE PERIOD (HRS.)	AIR FILTER CHANGE PERIOD (HRS.)
-10°F to +90°F (-23°C to +32°C)	Sullube	8000 (I)	8000 (I)	4000 (II)
	Sullair LLL-4-32	8000 (I)	8000 (I)	4000 (II)
	SRF 1/4000	4000	4000	4000 (II)
	D-A Torque Fluid	1000	1000	4000 (II)

(I) 8,000 Hours or once a year.

(II) 4,000 Hours or more frequently if conditions so require.

Section 8 MAINTENANCE

Figure 8-2 Oil Fill Port Location

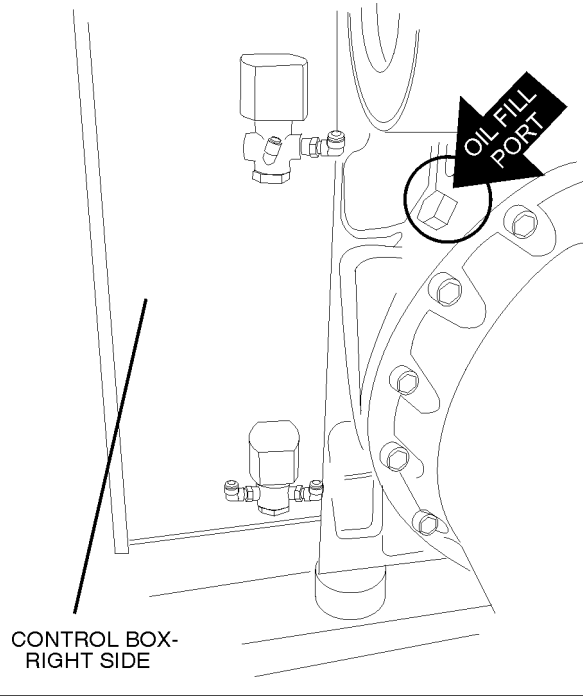

8.6 PARTS REPLACEMENT AND ADJUSTMENT PROCEDURES

⚠ WARNING

Before doing compressor maintenance, disconnect compressor from power source and lock out power source. Isolate compressor from line pres-

⚠ WARNING

Before doing compressor maintenance, disconnect compressor from power source and lock out power source. Isolate compressor from line pres-

Figure 8-3 Air Filter- Standard Model (043333)

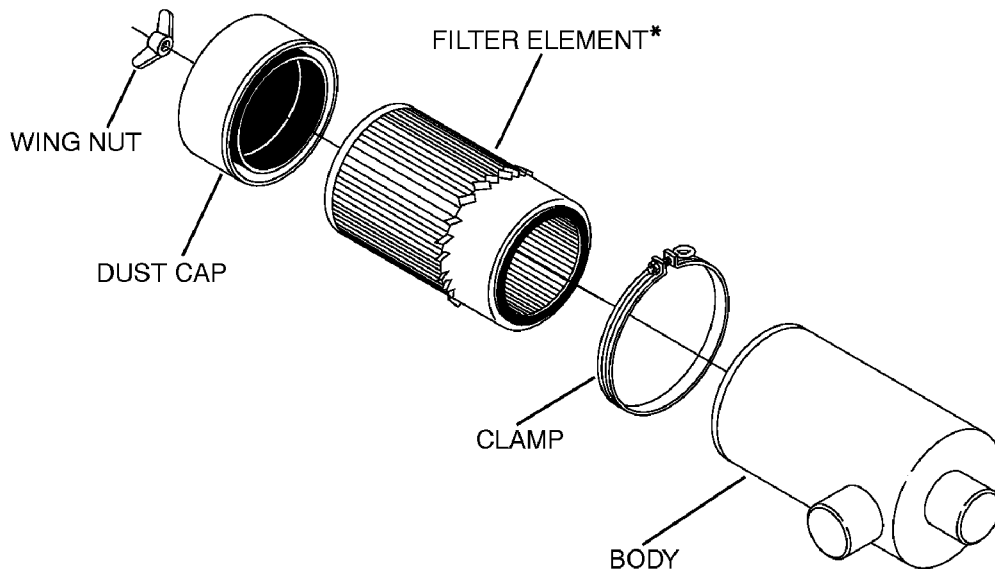

* Replacement Element Kit P/N 043334

sure by closing recommended discharge shut-off valve and releasing all internal pressure from compressor.

RELIEF VALVE

Check the relief valve at least weekly to see that it is functional. **DO NOT** tamper with the preset factory pressure setting of the valve. **DO NOT** plug the valve for any reason; should it leak, have it replaced.

FLUID FILTER REPLACEMENT

Refer to Figures 8-1 and 8-2.

1. To prevent spillage and loss of reusable fluid, place a contaminate-free fluid receptacle beneath fluid drain valve and fluid filter.
2. Drain fluid by removing fluid drain valve cap at tee located beneath compressor (for complete fluid change, drain fluid from cooler).
3. Using a strap wrench, remove the old element and gasket.
4. Clean gasket seating surface.
5. Apply a light film of fluid to the new gasket.
6. Hand tighten new element until gasket is seated.
7. Continue tightening element an additional 1/2 to 3/4 turn.
8. Replace fluid. **DO NOT OVERFILL.**
9. Restart compressor and check for leaks.

AIR FILTER MAINTENANCE-STANDARD MODEL

Refer to Figure 8-3. Air filter (P/N 043333) maintenance should be performed every 6 months or more frequent if conditions so require.

Figure 8-4 Air Filter- Basic Model (02250069-934)

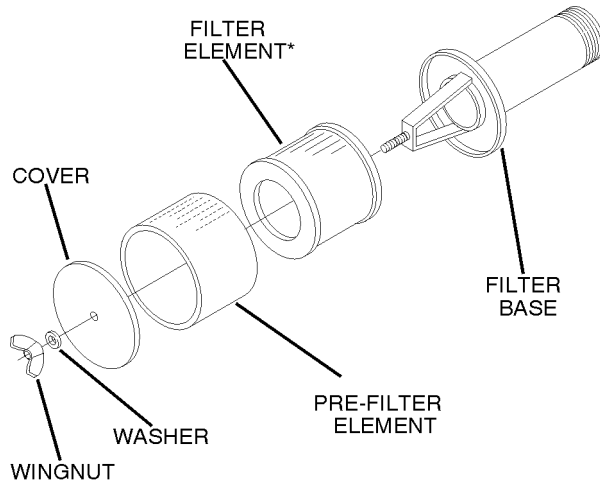

*Replacement Element P/N 02250094-135

sure by closing recommended discharge shut-off valve and releasing all internal pressure from compressor.

ELEMENT INSPECTION- STANDARD MODEL

1. Place a bright light inside the element to inspect for damage or leak holes. Concentrated light will shine through the element and locate any holes.
2. Inspect all gaskets and gasket contact surfaces of the housing. Should faulty gaskets be evident, correct the condition immediately.
3. If the clean element is to be stored for later use, it must be stored in a clean container.
4. After the element has been installed, inspect and tighten (if necessary) all air inlet connections prior to resuming operation.

AIR FILTER ELEMENT REMOVAL- STANDARD MODEL

1. Clean the exterior of the air filter housing.
2. Remove the dust cap by loosening the securing wingnut.
3. Pull element from body.
4. Clean the interior of the body by using a damp cloth. **DO NOT** use compressed air to remove the dirt.
5. Inspect the element; replace with new element if necessary.
6. Re-position element into the body.
7. Replace dust cap.
8. Replace wingnut.
9. Clean inside of dust cap.

AIR FILTER MAINTENANCE- BASIC MODEL

Refer to Figure 8-4. Air filter (P/N 02250069-934) maintenance should be performed every 6 months or more frequent if conditions so require.

ELEMENT INSPECTION- BASIC MODEL

1. Place a bright light inside the element to inspect for damage or leak holes. Concentrated light will shine through the element and locate any holes.

2. If the clean element is to be stored for later use, it must be stored in a clean container.

AIR FILTER ELEMENT REMOVAL- BASIC MODEL

1. Clean the exterior of the filter base and cover.
2. Loosen/remove the wingnut, washer and cover.
3. Remove element shield and element.
4. Clean filter base with a damp cloth. **DO NOT** use compressed air to remove the dirt.
4. Inspect the element; replace with new element if necessary.
5. Position element and pre-filter element in place.
6. Position cover over pre-filter element.
7. Reinstall washer and wingnut; tighten to secure.

SEPARATOR ELEMENT REPLACEMENT

Refer to Figure 8-5. The separator should be changed once a year. Follow the procedure explained below for element replacement.

⚠ WARNING

Before doing compressor maintenance, disconnect compressor from power source and lock out power source. Isolate compressor from line pressure by closing recommended discharge shut-off valve and releasing all internal pressure from compressor.

1. Insert a 100mm maximum length, 6mm diameter pin into the radially drilled hole in the separator cap. Loosen, unscrew counterclockwise and remove the cap.
2. Pull out the old element by gripping the end of the old element with channel lock pliers or a similar tool.
3. Install new o-rings on separator cap and separator element filter and oil lightly to make installation easier.
4. Insert and push the new element in place.
5. Reinstall the cap. Hand tighten using a 100mm maximum length, 6mm diameter pin in the radially drilled hole.

DRIVE COUPLING INSTALLATION

Refer to Figure 8-6. For coupling installation the tools required will be one set of metric Allen

Figure 8-5 Separator Element

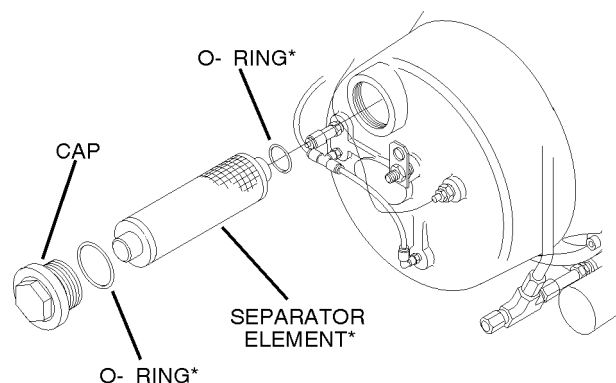

*Repair Kit P/N 02250106-791

Section 8 MAINTENANCE

Figure 8-6 Hub Separation

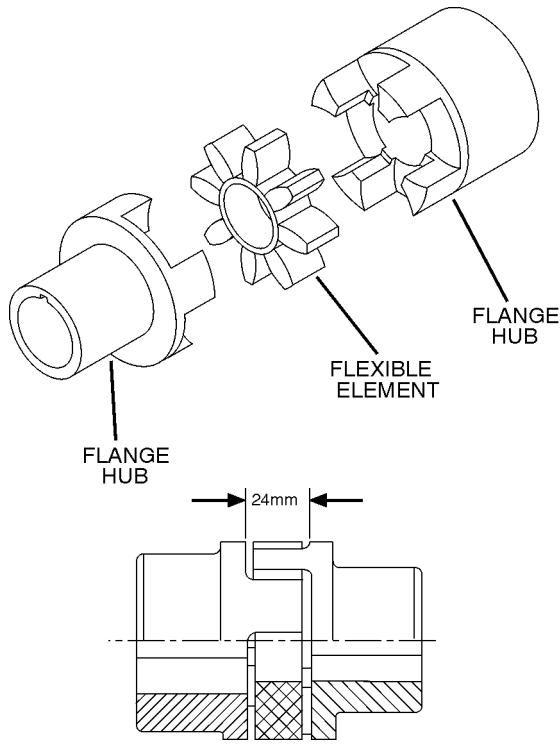

wrenches. All ES-8 compressors are flange-mounted to the motor making them self-aligning, eliminating the need for alignment procedures. Proper hub separation is shown in Figure 8-6.

INLET CONTROL VALVE

Refer to Figure 8-7. The inlet control valve normal maintenance requires only the replacement of the o-rings. Use repair kit no. 02250050-614 and follow the procedure below for proper disassembly and assembly procedures.

⚠ WARNING

Before doing compressor maintenance, disconnect compressor from power source and lock out power source. Isolate compressor from line pressure by closing recommended discharge shut-off valve and releasing all internal pressure from compressor.

⚠ WARNING

Assure that line pressure gauge on compressor indicates "ZERO" pressure before any work is done. Failure to comply can cause injury.

1. Remove the two (2) rear access panels which cover the inlet valve assembly.
2. Identify and tag the plastic lines connected to the blowdown valve and disconnect.

3. Remove the 3 capscrews from the inlet valve cover.
4. Remove cover (with blowdown valve attached) and o-rings.
5. Remove piston, piston spring, check spring and valve stem.
6. Inspect and clean all parts.
7. Assemble valve stem, check spring, piston spring and piston into inlet valve housing.
8. Lubricate new o-rings and install the inner and outer o-rings onto cover.
9. Position cover in inlet valve housing and install capscrews. Tighten capscrews to 6 ft.-lbs. (8.1Nm).
10. Reconnect the plastic lines to the appropriate fittings on the valve.
11. Assemble two (2) rear access panels on the compressor.
12. Start compressor and check for leaks.

CONTROL SYSTEM ADJUSTMENT- ELECTRO-MECHANICAL

Refer to Figure 8-8. Prior to adjusting the Control System, it is necessary to determine the desired operating pressure range and also the maximum pressure at which your compressor is to operate. The pressure must not exceed the maximum operating pressure which is stamped on the compressor serial number nameplate. The following explanation applies to a typical installation with a desired operating range of 100 to 110 psig (6.9 to 7.6 bar). This information will apply to a compressor with any other operating range excepting the stated pressures.

Remove the cover of the pressure switch. With the shut-off valve closed (or slightly cracked open) start the compressor. Observe the line pressure gauge and pressure switch contacts. When the line pressure reaches 110 psig (7.6 bar), the pressure switch contacts should open. If the pressure switch con-

Figure 8-7 Inlet Control Valve

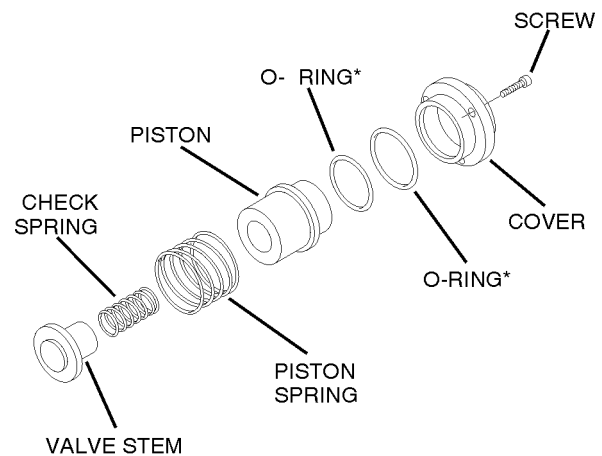

* Repair Kit P/N 02250050-614

Figure 8-8 Pressure Switch (P/N 040694)

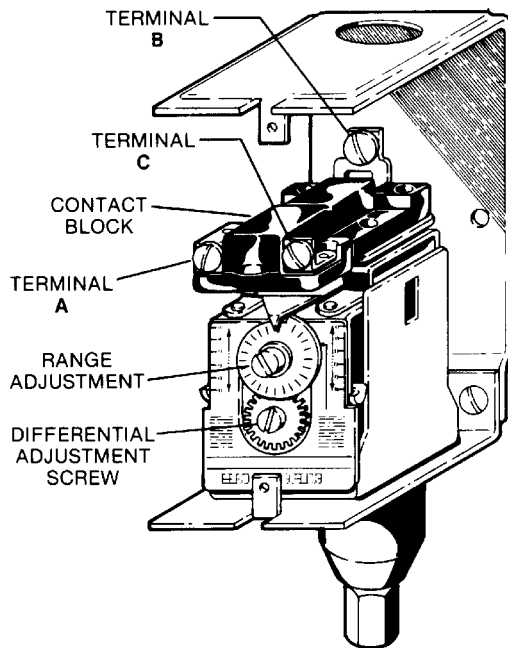

tacts do not open or they open prior to the desired pressure, the pressure switch setting will require adjustment.

FOR PRESSURE RANGE ADJUSTMENT:

1. Remove cover to pressure switch.
2. Turn the range adjusting screw to the high pressure setting. Turning the screw counterclockwise lowers both the high and low pressure equally.

FOR DIFFERENTIAL ADJUSTMENT:

Differential is the difference between the high and low pressure settings. 10 psig (0.7 bar) is typical.

1. Turn the differential adjusting screw to the lower (reset) setting. Turning the screw counterclockwise widens the differential by lowering the reset (lower) setting only.
2. When the pressure switch adjustment is complete, the pressure regulator should be adjusted for the pressure at which modulation of air delivery should begin. In this case that pressure will be 103 psig (7.1 bar). The regulator is adjusted by loosening the jam nut on the end of the cone shaped cover of the pressure regulator. When the jam nut is loose, turn the adjusting screw clockwise to increase or counterclockwise to decrease the setting.
3. To set the regulator, continue closing the service valve, until the line pressure is 103 psig (7.1 bar). At this point regulator should pass a signal to the inlet valve to start closing it. If the line pressure keeps on rising or if the modulation does not begin, adjust the regulator valve as described above. After adjustment line pressure should be approximately 103 psig (7.1 bar) and 1.00 in. Hg vacuum below the inlet.
4. Now close the service valve, line pressure will start rising. When line pressure reaches 110 psig. (7.6 bar), the inlet valve will be closed to its maximum position. The inlet vacuum at this point will be around 25 in. Hg. The machine should unload at this point.
5. Open the service valve so the line pressure is 100 psig (6.9 bar). Machine is now set for operation. Recheck the unload pressure by closing of the service valve. Machine should unload via the pressure switch at 110 psig (7.6 bar).

9.1 INTRODUCTION

The information contained in the Troubleshooting chart is based upon both the actual applied situations and extensive testing at the factory. It contains symptoms and usual causes for the described problems. However **DO NOT** assume that these are the only problems that may occur. All available data concerning the trouble should be systematically analyzed before undertaking any repair or component replacement procedures.

A detailed visual inspection is worth performing for

almost any problems which may prevent unnecessary damage to the compressor. Always remember to:

- a. Check for loose wiring.
- b. Check for damaged piping.
- c. Check for parts damaged by heat or an electrical short circuit, usually apparent by discoloration or a burnt odor.

Should your problem persist after making the recommended check, consult your nearest Sullair representative or the Sullair Corporation factory.

9.2 TROUBLESHOOTING

SYMPTOM	PROBABLE CAUSE	REMEDY
T1 HI Message	Discharge Temperature Exceeded 225°F (107°C) for Pre-Alarm	
	Discharge Temperature Exceeded 235°F (113°C) for Shutdown	
	Ambient temperature exceeded 105°F (41°C)	Improve local ventilation (i.e., remote intake of process and/or cooling air.
	Fluid Level in Sump is Too Low	Check/correct fluid level.
	Thermal Valve Malfunctioned	Check/replace thermal valve.
	Cooler Fins are Dirty	Clean cooler fins.
	Water Flow is Low (water-cooled packages only)	Check cooling water supply (i.e., closed valves).
	Water Temperature is High (water-cooled packages only)	Increase water flow, lower water temperature.
P1 HI Message	Cooler is Plugged (water-cooled packages only)	Clean tubes and/or shell - if tube plugging persists, provide cleaner water.
	Temperature RTD Malfunction	Check connections from RTD. If adequate, replace RTD.
	Discharge Pressure Exceeded Shutdown Level Because: P1 MAX-3psi (0.2 Bar) Exceeded for Pre-Alarm	
	P1 MAX Exceeded for Shutdown	
SEP MNTN Message	Unloading Device (i.e., Blowdown Valve, Sullicon Actuator, Optional Spiral Valve) Failed to Operate	Check operation of unloading device.
	Pressure Regulator Maladjusted	Check operation of pressure regulator.
	Solenoid Valve Failed to Operate	Check operation of solenoid valve.
	Control Air Signal Leaks	Check tubework feeding control signal for leaks.
	Control Air Signal Filter Clogged	Service filter assembly.
P1, P2, P3 FAIL	Plugged Separator	Replace separator elements.
	dP1 > 10 psi	Check P1 & P2 pressure transducers.
	Pressure Transducer Malfunction	Check connections from transducer. If connections are good, replace transducer.

Section 9

TROUBLESHOOTING

9.2 TROUBLESHOOTING (CONTINUED)

SYMPTOM	PROBABLE CAUSE	REMEDY
COMPRESSOR DOES NOT BUILD FULL DISCHARGE PRESSURE	Air Demand Exceeds Supply	Check air service lines for open valves or leaks.
	Inlet Air Filter Clogged	Check for maintenance message on Supervisor display. Inspect and/or change element.
	Inlet Valve Not Fully Open	Check actuation and butterfly disc position.
	Pressure Sensor and/or Connections at Fault	Check connections from transducer. If adequate, replace transducer.
LINE PRESSURE RISES ABOVE UNLOAD SETTING	Pressure Sensor P2 at Fault	Check connections from transducer. If adequate, replace transducer.
	Unloading Device (i.e., Blowdown Valve, Sullicon Actuator, Optional Spiral Valve) Failed to Operate	Check operation of unloading device.
LINE PRESSURE RISES ABOVE UNLOAD SETTING	Solenoid Valve Failed to Operate	Check operation of solenoid valve.
	Control Air Signal Leaks	Check tubework feeding control signal for leaks.
	Control Air Signal Filter Clogged	Service filter assembly.
EXCESSIVE FLUID CONSUMPTION	Clogged Return Line Strainer or Orifice	Clean strainer - screen and o-ring replacement kit available. Clean orifice.
	Damaged or Improperly Gasketed Separator Elements	Inspect separator elements and gaskets. Replace if damaged.
	Fluid System Leaks	Check tube/pipework for leaks.
	Fluid Level Too High	Drain excess fluid.
	Excessive Fluid Foaming	Drain and change fluid.



NOTE ON TRANSDUCERS:

Whenever a sensor is suspected of fault, the recommended cause of action is to measure the signal (pressure, temperature, etc.) with an alternate calibrated instrument and compare readings. If readings conflict, the electrical and/or tubing connections should be inspected, and if no faults are evident, then replace the sensor and re-evaluate against the calibrated instrument.

9.3 CALIBRATION

The Supervisor II has software calibration of the pressure and temperature probes. This calibration affects the offset but not the slope of the pressure and temperature calculations. Because of this, the most accurate method is to heat or pressurize the transducer to its operating value. If this is too difficult, room temperature/open atmosphere calibration is adequate. Calibration may only be done while machine is stopped and unarmed.

To enter calibration mode, you must press the following keys in sequence while in the default status

display mode: “”, “▲”, “▼ ”, PRG. Once in calibration mode, you will see a screen like the following:

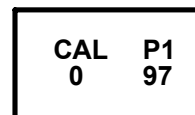

In the above example, “0” refers to the amount of adjustment (in psi or °F, “97” refers to the current value of P1).

To make adjustments, Press the “▲” (UP ARROW) key to increase the value, press the “▼ ” (DOWN ARROW / LAMP TEST) key to decrease the value. The number on the left will increase or decrease always showing the total amount of adjustment. Maximum adjustment is + 7.

The **DSP** key exits, wiping out changes to the current item, while saving changes to any previous items. The **PRG** key saves the current item and advances to the next. All temperatures and pressures may be calibrated individually.

NOTES

ILLUSTRATIONS AND PARTS LIST

ES-8 COMPRESSOR ASSEMBLY, EXPLODED VIEW

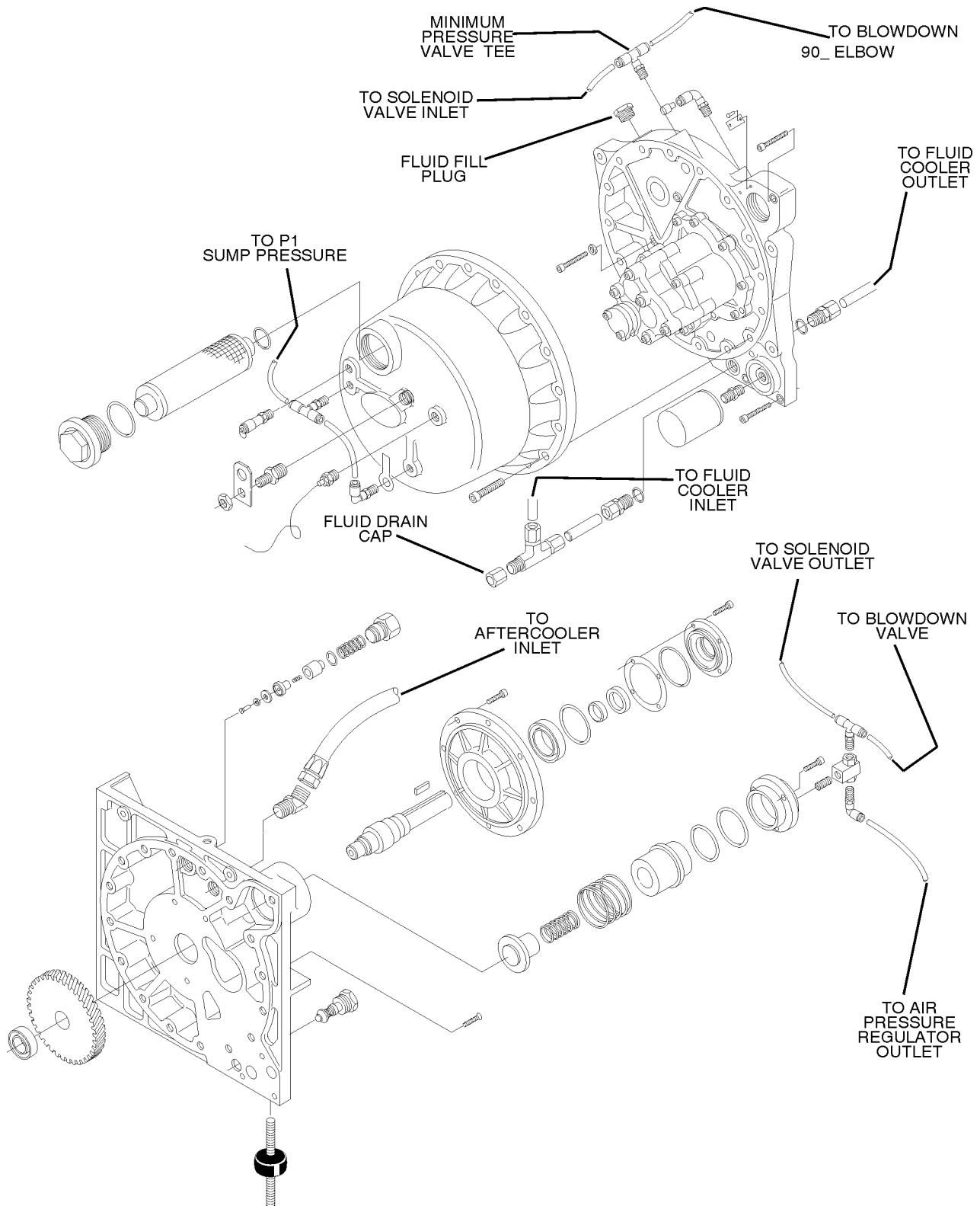

ILLUSTRATIONS AND PARTS LIST

10.1 PROCEDURE FOR ORDERING PARTS

Parts should be ordered from the nearest Sullair Representative or the Representative from whom the compressor/dryer was purchased. If for any reason parts cannot be obtained in this manner, contact the factory directly at the addresses, phone or fax numbers below.

When ordering parts always indicate the **Serial Number** of the compressor/dryer. This can be obtained from the Bill of Lading for the compressor/dryer or from the Serial Number Plate located on the compressor/dryer.

The genuine Sullair service parts listed meet or exceed the demands of this compressor. Use of replacement parts other than those approved by Sullair Corporation may lead to hazardous conditions over which Sullair Corporation has no control. Such conditions include, but are not limited to, bodily injury and compressor failure.

SULLAIR ASIA, LTD.
Sullair Road, No. 1
Chiwan, Shekou
Shenzhen, Guangdong PRV.
PRC POST CODE 518068
Telephone: 755-6851686
Fax: 755-6853473

SULLAIR EUROPE, S.A.
Zone Des Granges BP 82
42602 Montbrison Cedex, France
Telephone: 33-477968470
Fax: 33-477968499

SULLAIR CORPORATION
3700 East Michigan Boulevard
Michigan City, Indiana 46360 U.S.A.
Telephone: 1-219-879-5451
Fax: (219) 874-1273
Fax: (219) 874-1835 (Parts)
Fax: (219) 874-1288 (Service)

10.2 RECOMMENDED SPARE PARTS LIST

DESCRIPTION	KIT NUMBER	QUANTITY
repair kit for fluid filter 250026-982	02250050-602	1
repair kit for air/fluid separator	02250106-791	1
repair kit for air filter 02250107-327	043334	1
repair kit for shaft seal	02250061-961	1
tool kit, shaft seal	001932-005	1
replacement element for thermal valve	045764	1
replacement kit for coil 250028-809	250028-387	1
repair kit for pressure regulator valve 250017-280	250019-435	1
repair kit for inlet control valve	02250050-614	1
replacement coil for solenoid valve 250030-164	250035-292	1
repair kit for solenoid valve 250030-164	250038-849	1
repair kit for minimum pressure/check valve	02250050-612	1
repair kits for separator filter 02250052-689		
Sauto drain kit	250031-245	2
Ssight glass kit	250024-295	2
So-ring kit	02250056-270	2
repair kit for MPF filter 250024-361	250024-427	1
replacement element for coupling 250042-728	02250048-344	1
fluid, Sullube (five gallons)	250022-669	1
manual, Sequencing & Protocol (I)	02250057-696	1

(I) This document is required to program your personal computer to communicate with the Supervisor II panel.

PLEASE NOTE: WHEN ORDERING PARTS, INDICATE SERIAL NUMBER OF COMPRESSOR

ILLUSTRATIONS AND PARTS LIST

10.3 INLET CONTROL, SEAL/DRIVE GEAR AND PARTS

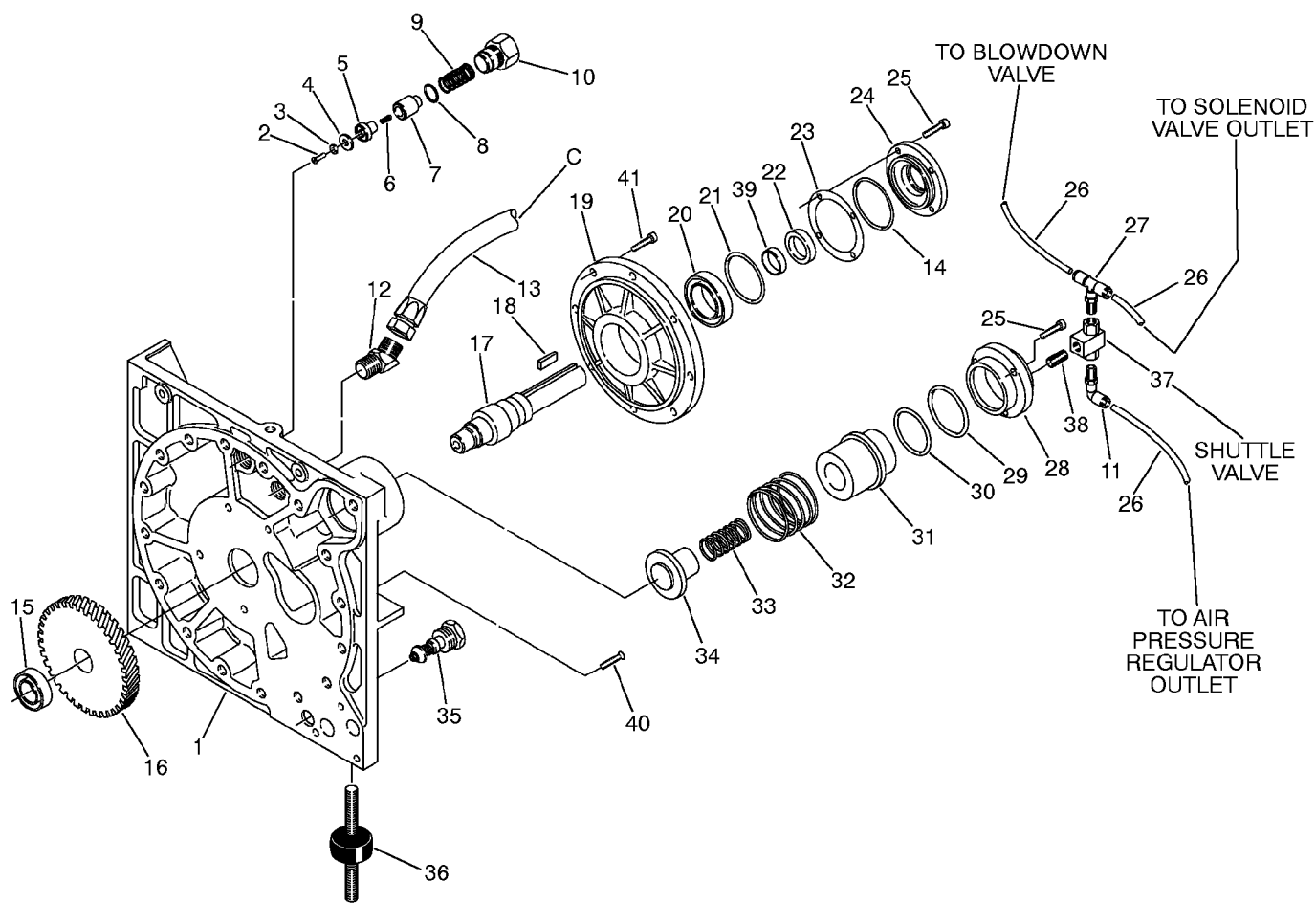

ILLUSTRATIONS AND PARTS LIST

10.3 INLET CONTROL, SEAL/DRIVE GEAR AND PARTS

<i>key number</i>	<i>description</i>	<i>part number</i>	<i>quantity</i>
1	housing, drive	02250045-827	1
2	screw, flat hd M6 x 12MM	865006-012	1
3	washer	02250048-229	1
4	seat, minimum pressure valve (I)	02250047-162	1
5	stem, minimum pressure valve	02250047-163	1
6	spring, minimum pressure valve (I)	02250047-296	1
7	piston, minimum pressure valve	02250048-908	1
8	o-ring, viton 1 1/4" x 3/32" (I)	826502-124	1
9	spring, minimum pressure valve	02250047-161	1
10	cap, minimum pressure valve	250035-587	1
11	elbow, 90 M 1/4" x 1/4"	250025-850	1
12	elbow, 45 37FL 1.312"	02250046-908	1
13	hose, medium pressure 1" x 11.25"	02250107-919	1
14	o-ring viton 3 1/4" x 3/32" (II)	826502-152	1
15	bearing	499080-206	1
16	gear	consult factory	1
17	shaft, input	02250050-540	1
18	key, 10 x 8 x 70	865210-070	1
19	housing, cover drive	02250055-887	1
20	bearing	499080-210	1
21	o-ring, viton 3 1/4" x 3/32" (II)	826502-152	1
22	seal (II)	02250048-316	1
23	shim, set 3.5 x 3.0	220645	1
24	cover, shaft seal	250035-254	1
25	capscrew, M8 x 20MM	829308-020	7
26	hose, nylon 1/4"	02250054-861	5 ft.
27	tee, swivel 1/4" x 1/4"	250025-835	1
28	cover, inlet control	02250119-254	1
29	o-ring, viton 3 1/8" x 1/8"	826502-235	1
30	o-ring, viton 2" x 1/8"	826502-226	1
31	piston, inlet valve	02250048-909	1
32	spring, inlet piston	250042-087	1

(Continued on page 41)

(I) For maintenance on minimum pressure valve, order kit no. 02250050-612 (Note: Items not sold separately).

(II) For maintenance on ES-8 shaft seal, order tool kit part numbers 02250061-961 and 001932-005.

PLEASE NOTE: WHEN ORDERING PARTS, INDICATE SERIAL NUMBER OF COMPRESSOR

ILLUSTRATIONS AND PARTS LIST

10.3 INLET CONTROL, SEAL/DRIVE GEAR AND PARTS

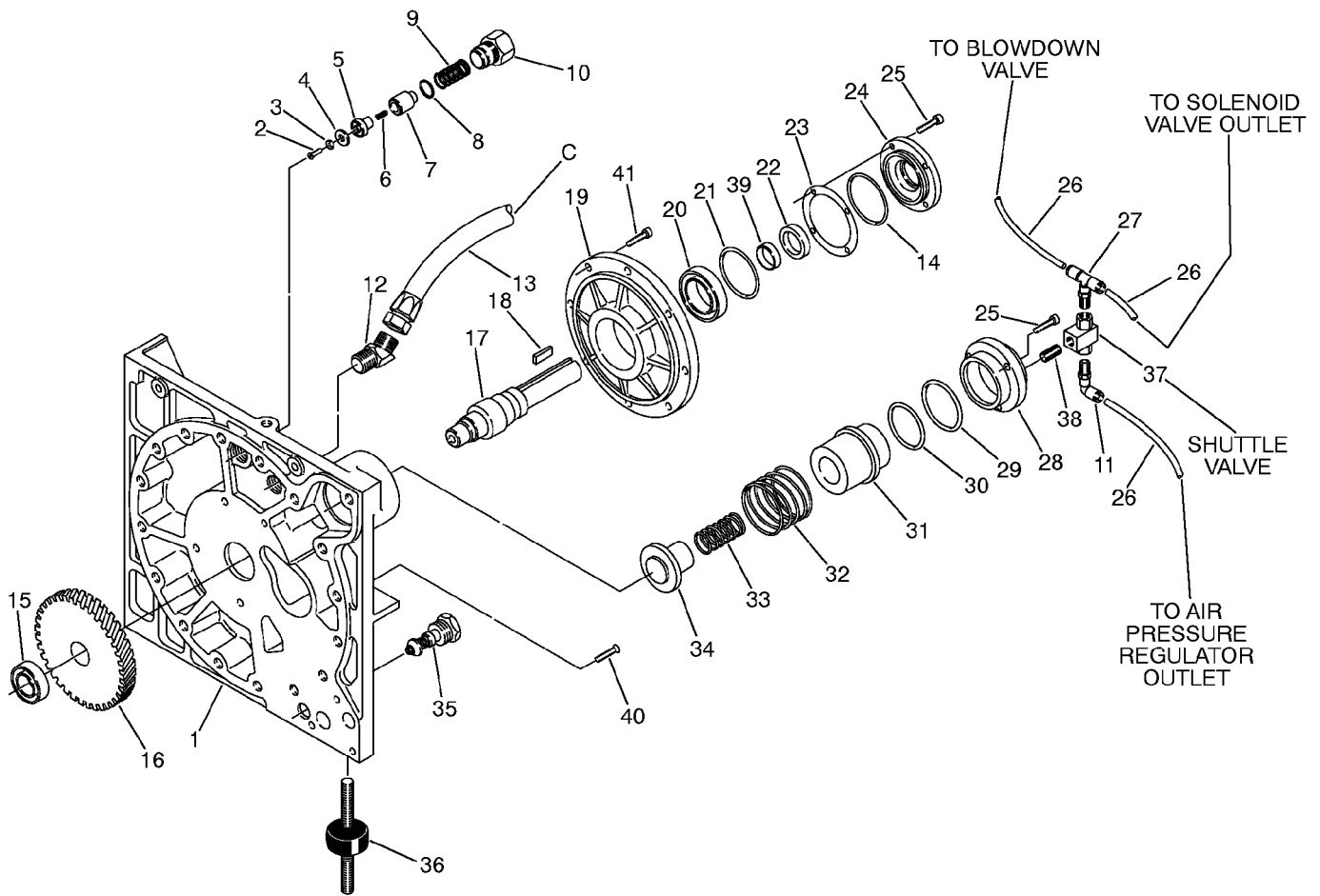

ILLUSTRATIONS AND PARTS LIST

10.3 INLET CONTROL, SEAL/DRIVE GEAR AND PARTS (CONTINUED)

<i>key number</i>	<i>description</i>	<i>part number</i>	<i>quantity</i>
33	spring, inlet check	250042-088	1
34	stem, inlet valve	250035-584	1
35	element, thermal valve	045764	1
36	isolator, vibration	02250047-047	2
37	valve, shuttle 1/4"	408893	1
38	nipple, pipe 1/4" x close	823204-000	2
39	sleeve, wear (II)	02250048-317	1
40	screw, sltd ft point	250042-203	1
41	screw, socket M12 x 30MM	829312-030	8

(II) For maintenance on ES-8 shaft seal, order tool kit part numbers 02250061-961 and 001932-005.

PLEASE NOTE: WHEN ORDERING PARTS, INDICATE SERIAL NUMBER OF COMPRESSOR

ILLUSTRATIONS AND PARTS LIST

10.4 MOTOR, COUPLING, FAN AND PARTS

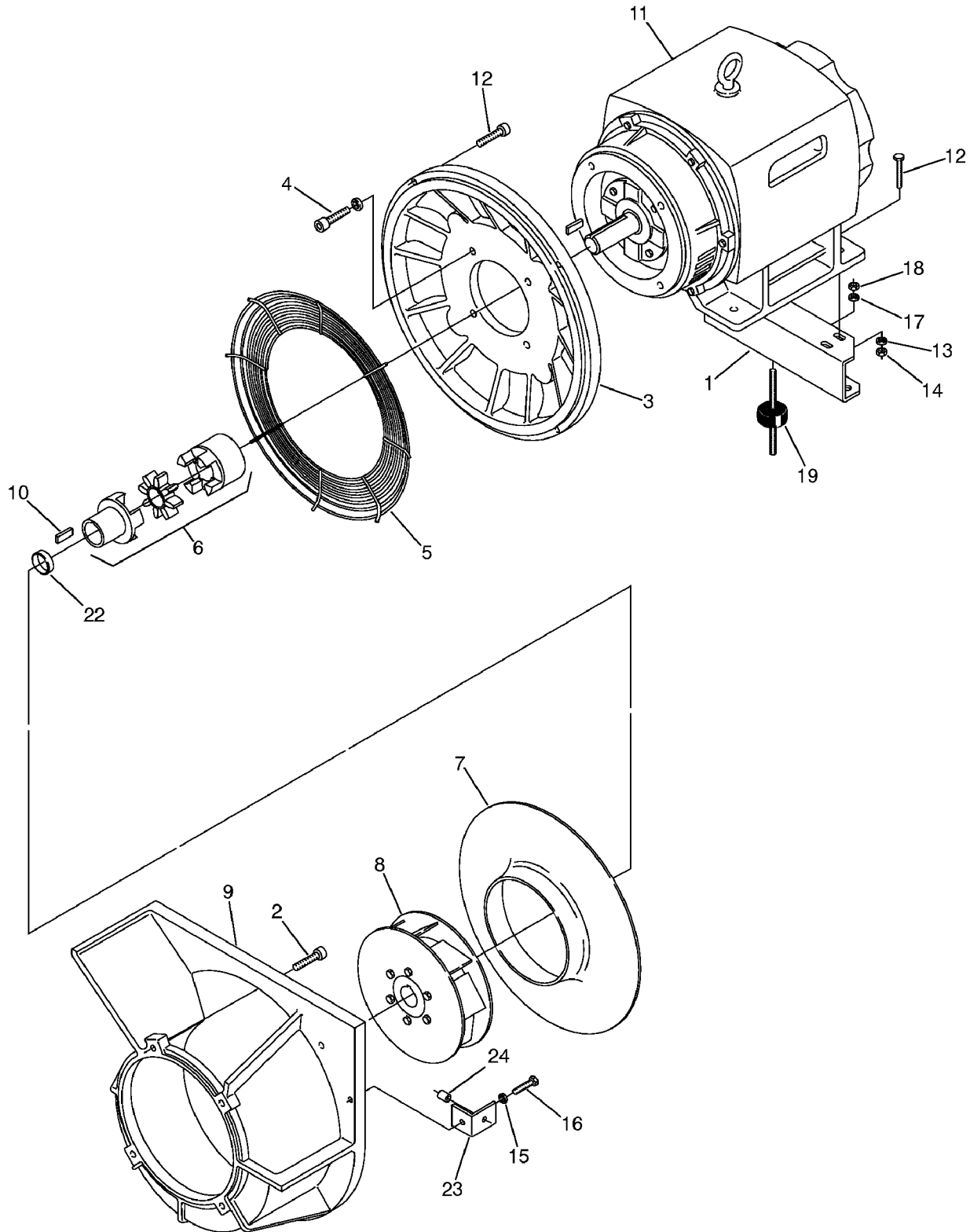

ILLUSTRATIONS AND PARTS LIST

10.4 MOTOR, COUPLING, FAN AND PARTS

<i>key number</i>	<i>description</i>	<i>part number</i>	<i>quantity</i>
1	support, motor (15, 20, 25 HP/11, 15, 18.5 KW)	02250046-622	1
	Ssupport, motor (30 HP/22 KW)	02250046-624	1
2	capscrew, M12 x 30MM	829312-030	4
3	housing, adaptor motor (15, 20, 25 HP/11, 15, 18.5 KW)	02250045-831	1
	Shousing, adaptor motor (30 HP/22 KW)	02250045-833	1
4	capscrew, hex GR8 1/2"-13 x 1 1/4"	829408-125	4
5	guard, fan	02250055-600	1
6	coupling, 1 5/8" (I)	250042-728	1
7	venturi, fan inlet (15, 20 HP/11, 15 KW)	02250050-241	1
	Sventuri, fan inlet (25, 30 HP/18.5, 22 KW)	02250046-603	1
8	fan, backward inclined wheel (15, 25, 30 HP/11, 15, 18.5 KW) (I)	02250050-539	1
	Sfan, backward inclined wheel (20 HP/15 KW) (I)	02250050-240	1
9	housing, fan	02250045-829	1
10	key, 10 x 8 x 40	865210-040	1
11	motor	consult factory	1
12	screw, socket M12 x 40MM	829312-040	6
13	washer, 12MM	865712-370	2
14	nut, M12 x 1.75	825912-175	2
15	washer, 8MM	865408-170	1
16	capscrew, 8MM x 16MM	828008-016	1
17	washer, 12MM	865712-370	1
18	nut, hex M12 x 1.75	825912-175	1
19	isolator, vibration 75MM x 50MM	02250047-047	1
20	elbow, 45 liq-tite 1 1/4" (not shown)	846500-125	1
21	washer, conduit red. 1 1/2"-1" (not shown)	847006-040	2
22	spacer, shaft (15, 20, 25 HP/11, 15, 18.5 KW)	02250049-354	1
	Sspacer, shaft (30 HP/22 KW)	02250049-159	1
23	angle, support cooler	02250046-915	1
24	insert, 6MM	02250047-083	1

(I) Pre-heating required before assembly. For maintenance, order element no. 02250048-344.

PLEASE NOTE: WHEN ORDERING PARTS, INDICATE SERIAL NUMBER OF COMPRESSOR

ILLUSTRATIONS AND PARTS LIST

10.5 INLET FILTER, COMPRESSOR HOUSING/SUMP AND PARTS- STANDARD

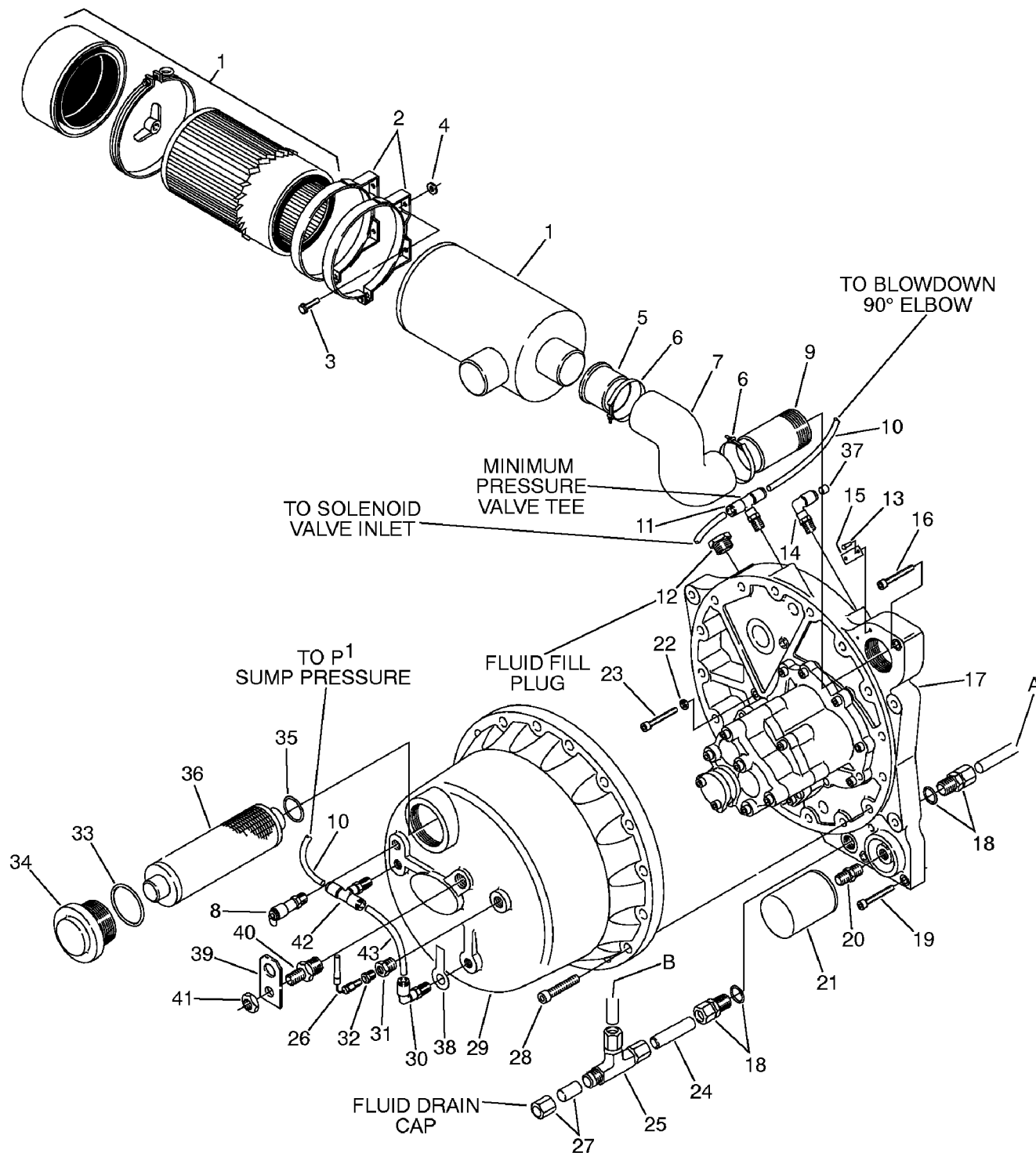

ILLUSTRATIONS AND PARTS LIST

10.5 INLET FILTER, COMPRESSOR HOUSING/SUMP AND PARTS- STANDARD

<i>key number</i>	<i>description</i>	<i>part number</i>	<i>quantity</i>
1	filter, air cyclopac 6 1/2" (I)	02250107-327	1
2	band, mounting 6 1/2"	043370	2
3	capscrew, M6 x 16MM	828006-016	4
4	washer, 6MM	865406-125	4
5	reducer, hose 2 1/2" x 2 1/4"	049779	1
6	clamp, hose	250018-550	2
7	elbow, rubber 90 2 1/2" 1 piece	02250048-321	1
8	valve, pressure relief 1/2" (200 psi/13.8 bar)	250006-938	1
9	nipple, air intake	02250047-425	1
10	hose, nylon (black)	842215-004	3
11	tee, branch swivel 1/4"T x 1/8"NPT	250025-834	1
12	plug, oil fill hex	250039-359	1
13	screw, drive #8 x 3/8"	839608-060	2
14	elbow, 90 1/8"NPT x 1/4"T	250025-849	1
15	plate, identification	250026-859	1
16	capscrew, socket M16 x 70MM	829316-070	1
17	hsg, inlet plate E08E	02250055-933	1
18	connector, tube 3/4"	811812-106	2
19	capscrew, socket M16 x 60MM	829316-060	4
20	adapter, oil filter	250025-914	1
21	element, fluid filter (II)	250026-982	1
22	washer, 8MM	865408-170	3
23	capscrew, socket M8 x 60MM	839308-060	3
24	tube, oil drain extension	02250046-999	1
25	tee, tube 3/4"	811412-075	1
26	probe, rtd	02250048-457	1
27	plug, oil	02250093-566	1
28	capscrew, M16 x 100MM	829316-100	16
29	housing, bell	250034-035	1
30	elbow, 90 1/4" x 1/4"	250025-850	2
31	bushing, reducing 1/2" x 1/8"	807102-005	1
32	fitting, compression	250028-635	1
33	o-ring, viton 3 1/8" x 1/8" (III)	826502-235	1

(Continued on page 47)

(I) For maintenance on air filter no. 02250107-327, order repair kit no. 043334.

(II) For maintenance on fluid filter no. 250026-982, order repair kit no. 02250050-602.

(III) For maintenance on air/fluid separator, order repair kit no. 02250106-791.

PLEASE NOTE: WHEN ORDERING PARTS, INDICATE SERIAL NUMBER OF COMPRESSOR

ILLUSTRATIONS AND PARTS LIST

10.5 INLET FILTER, COMPRESSOR HOUSING/SUMP AND PARTS- STANDARD

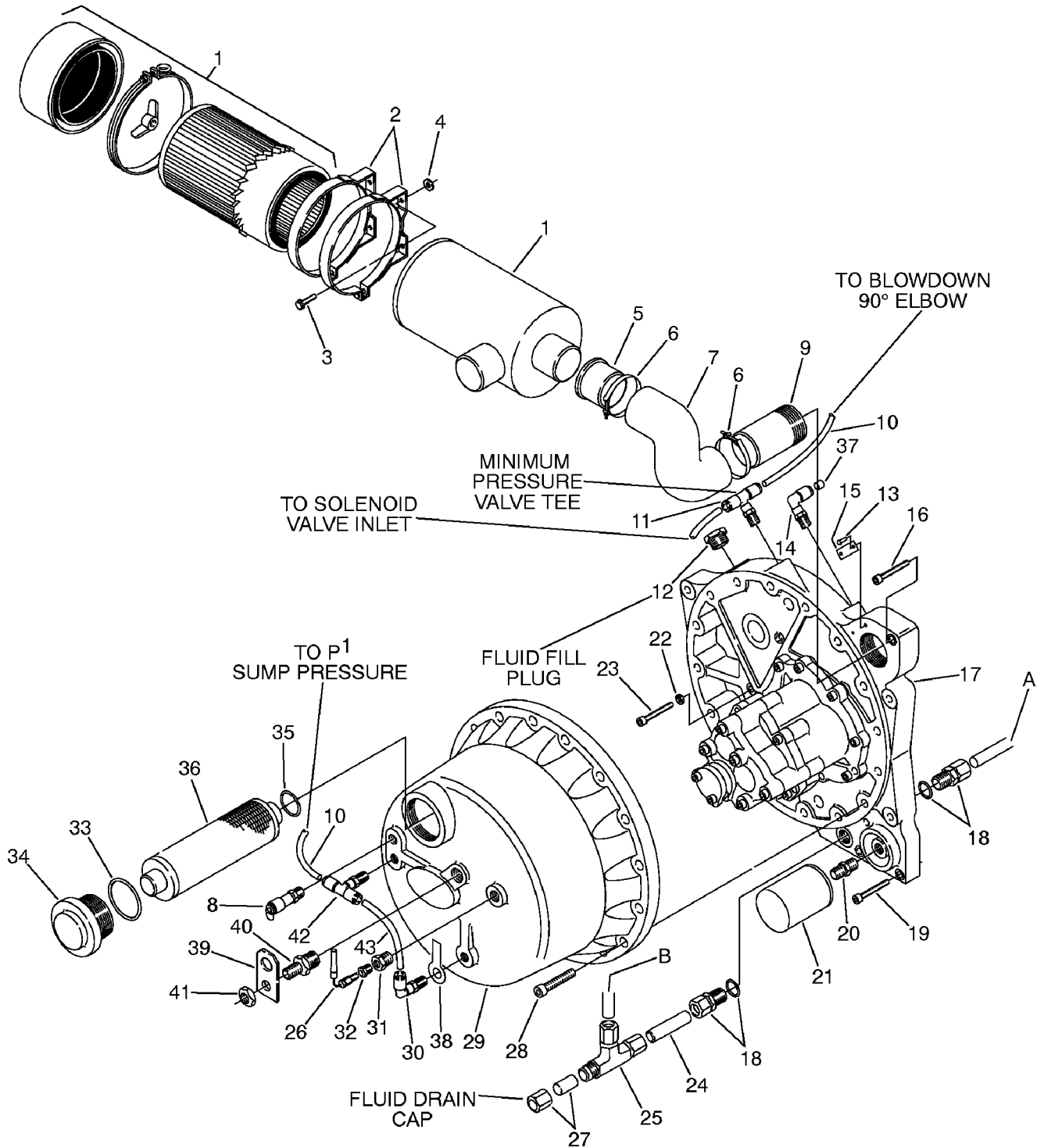

ILLUSTRATIONS AND PARTS LIST

10.5 INLET FILTER, COMPRESSOR HOUSING/SUMP AND PARTS- STANDARD (CONTINUED)

<i>key number</i>	<i>description</i>	<i>part number</i>	<i>quantity</i>
34	cap, separator element	250035-590	1
35	o-ring, viton 1 7/16" x 3/32" (III)	826502-127	1
36	element, separator (III)	02250106-789	1
37	plug, push-lok 1/4" tube	02250052-477	1
38	decal, fluid level	see decal section	1
39	bail lifting	02250054-858	1
40	plug, 1/2"-14 x M20	02250054-857	1
41	nut, hex M20 thin	02250055-630	1
42	tee, swivel	250025-835	1
43	hose, nylon (white)	02250054-860	0.83 ft

(III) For maintenance on air/fluid separator, order repair kit no. 02250106-791.

PLEASE NOTE: WHEN ORDERING PARTS, INDICATE SERIAL NUMBER OF COMPRESSOR

ILLUSTRATIONS AND PARTS LIST

10.6 INLET FILTER, COMPRESSOR HOUSING/SUMP AND PARTS- BASIC

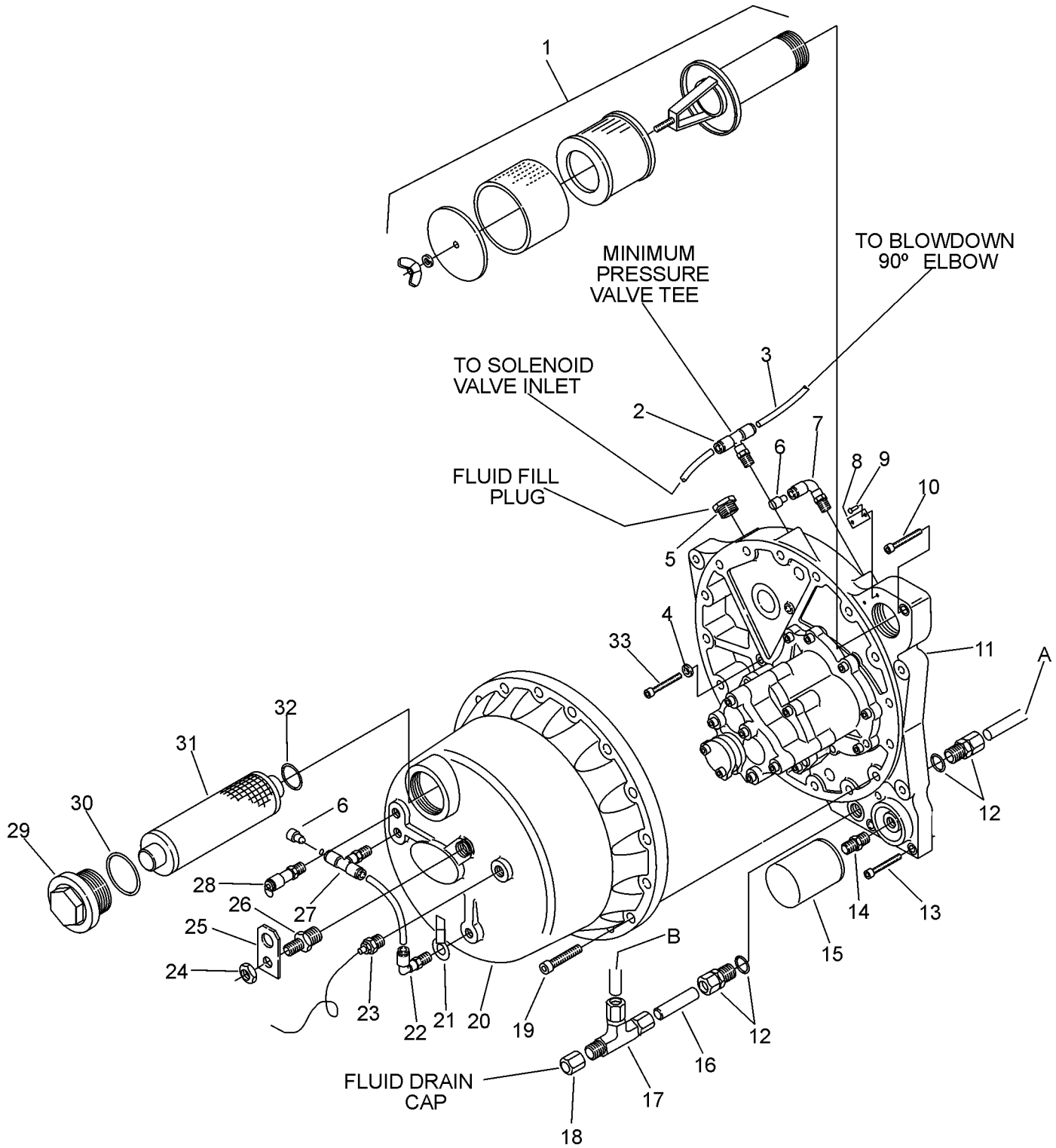

ILLUSTRATIONS AND PARTS LIST

10.6 INLET FILTER, COMPRESSOR HOUSING/SUMP AND PARTS- BASIC

<i>key number</i>	<i>description</i>	<i>part number</i>	<i>quantity</i>
1	filter, air (I)	02250069-934	1
2	tee, branch swivel 1/4" T x 1/8" NPT	250025-834	1
3	hose, nylon	842215-004	3
4	washer, 8MM	865408-170	3
5	plug, oil fill hex	250039-359	1
6	plug, push-lok 1/4" tube	02250052-477	2
7	elbow, 90_ 1/8" NPT x 1/4" T	250025-849	1
8	plate, identification	250026-859	1
9	screw, drive #8 x 3/8"	839608-060	2
10	capscrew, socket M16 x 70MM	829316-070	1
11	housing, inlet plate	02250055-933	1
12	connector, tube 3/4"	02250048-819	2
13	capscrew, socket M16 x 60MM	829316-060	2
14	adapter, oil filter	250025-914	1
15	element, fluid filter (II)	250026-982	1
16	tube, oil drain extension	02250046-999	1
17	tee, tube 3/4"	811412-075	1
18	cap, tube 3/4"	250042-615	1
19	capscrew, M16 x 100MM	829316-100	16
20	housing, bell	250034-035	1
21	decal, fluid level	see decal section	1
22	elbow, 90_ 1/4" x 1/4"	250025-850	3
23	sender, temperature gauge	02250069-626	1
24	nut, hex M20 thin	02250055-630	1
25	bail, lifting	02250054-858	1
26	plug, 1/2"-14 x M20	02250054-857	1
27	tee, swivel	02250025-835	1
28	valve, pressure relief 1/2" (200 PSI)	250006-938	1
29	cap, separator element	250035-590	1
30	o-ring, viton 3 1/8" x 1/8"	826502-235	1
31	element, separator (III)	02250106-789	1
32	o-ring, viton 1 7/16" x 3/32"	826502-127	1
33	capscrew, socket M8 x 60MM	839308-060	3

(I) For maintenance on air filter, order repair kit no. 02250094-135.

(II) For maintenance on fluid filter, order repair kit no. 02250050-602.

(III) For maintenance on separator element, order repair kit no. 02250106-791.

PLEASE NOTE: WHEN ORDERING PARTS, INDICATE SERIAL NUMBER OF COMPRESSOR/DRYER.

ILLUSTRATIONS AND PARTS LIST

10.7 COMPRESSOR COOLER SYSTEM AND PARTS

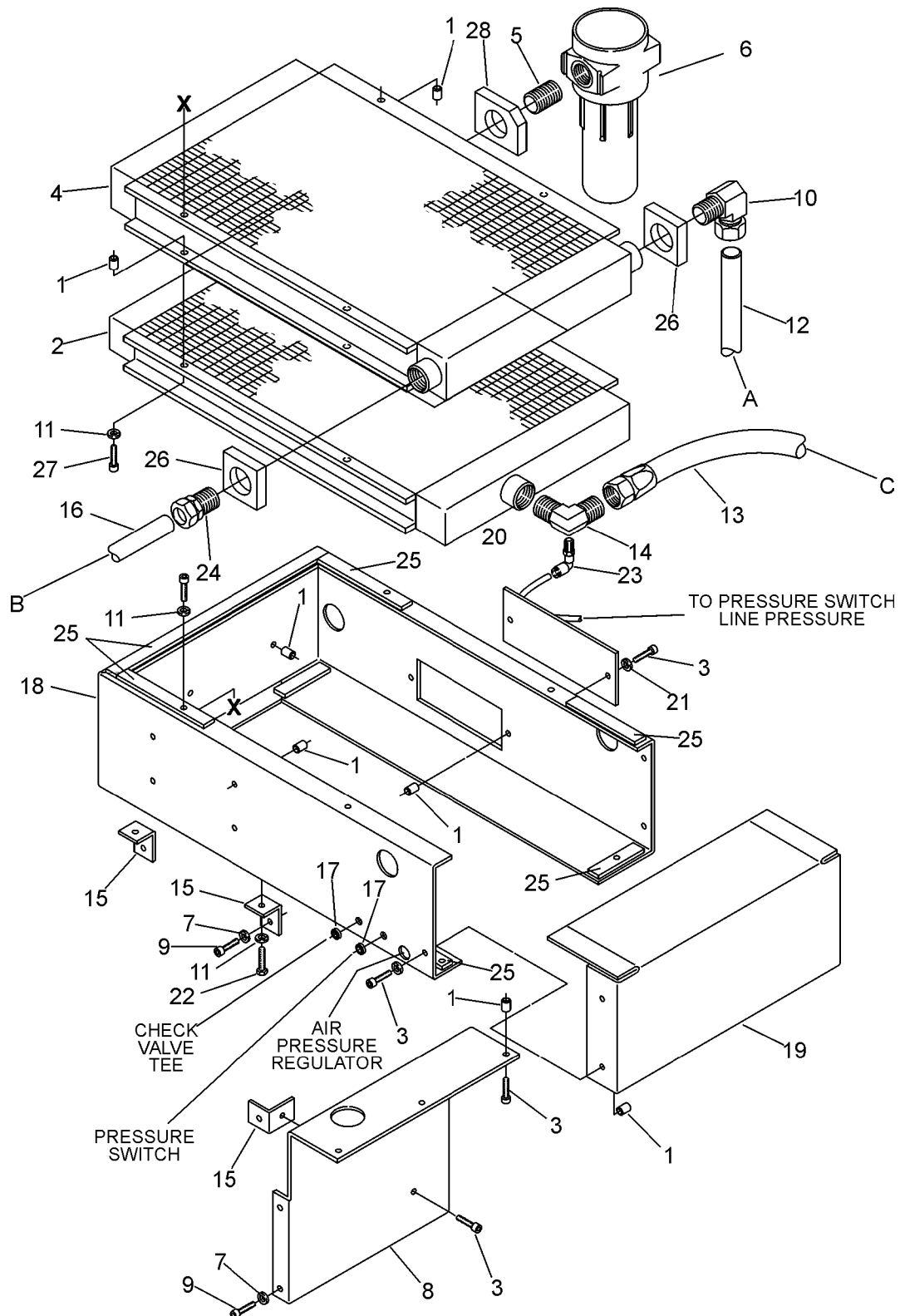

ILLUSTRATIONS AND PARTS LIST

10.7 COMPRESSOR COOLER SYSTEM AND PARTS

<i>key number</i>	<i>description</i>	<i>part number</i>	<i>quantity</i>
1	insert, threaded blind 6MM	02250047-083	20
2	aftercooler	250040-092	1
3	capscrew, M6 x 12MM	829306-012	10
4	cooler, oil (15,20 HP)	250039-096	1
	Scooler, oil (25,30 HP)	02250086-812	1
5	nipple, pipe 3/4" x 2"	823112-020	1
6	filter, air/separator/trap (I)	02250052-689	1
7	washer, 8MM	865408-170	7
8	cover, access	02250046-910	1
9	capscrew, 8M x 16MM	829308-016	6
10	elbow, tube 3/4"	02250048-820	1
11	washer, 6MM	865706-180	8
12	tube, oil in	02250047-245	1
13	hose, medium pressure 1" x 11.25"	02250107-919	1
14	elbow, 90_ 37FL	02250048-094	1
15	angle, support cooler	02250046-915	5
16	tube, oil out	02250047-244	1
17	grommet, rubber	040125	2
18	support, cooler (15,20 HP)	02250045-567	1
	Ssupport, cooler (25,30 HP)	02250048-302	1
19	cover, end coler support	02250046-911	1
20	cover, access cooler support	02250048-123	1
21	washer, 6MM	865406-125	2
22	capscrew, hex 6M x 16MM	828006-016	4
23	elbow, 90_ swivel 1/8" NPT	250025-849	1
24	connector, straight thd	02250048-819	1
25	weatherstrip, 1/2" x 1" (ft)	245738	5.5
26	foam, cooler oil/air	02250052-480	2
27	capscrew, M6 x 20MM	829306-020	8
28	foam, cooler after	02250052-481	1

(I) For maintenance on air/separator trap filter no. 02250052-689, order:

Sauto drain kit	250022-965	2
Ssight glass kit	250024-295	2
So-ring kit	02250056-270	2

PLEASE NOTE: WHEN ORDERING PARTS, INDICATE SERIAL NUMBER OF COMPRESSOR

Section 10

ILLUSTRATIONS AND PARTS LIST

10.8 CONTROL BOX AND PARTS- SUPERVISOR II

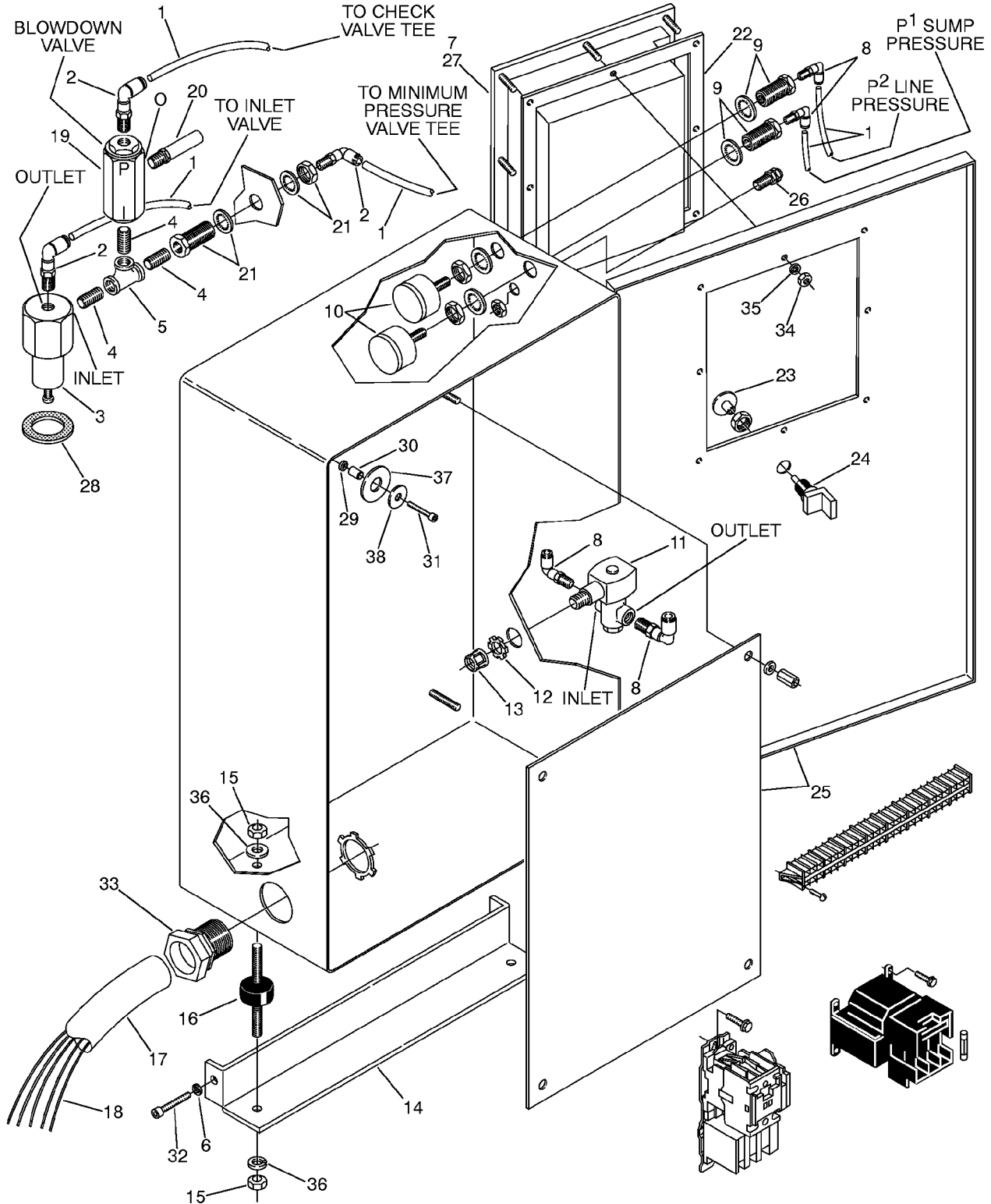

ILLUSTRATIONS AND PARTS LIST

10.8 CONTROL BOX AND PARTS- SUPERVISOR II

<i>key number</i>	<i>description</i>	<i>part number</i>	<i>quantity</i>
1	hose, nylon 1/4"	842215-004	15 ft
2	elbow, 90 1/4" x 1/4"	250025-850	2
3	valve, pressure regulator (I)	250017-280	1
4	nipple, pipe 1/4" x close	823204-015	3
5	tee, pipe 1/4"	804415-010	1
6	washer, 8MM	865408-170	2
7	control, supervisor panel	02250071-542	1
8	elbow, 90 1/8" NPT x 1/4" tube	250025-849	4
9	bulkhead, pipe 1/8"	841500-002	2
10	transducer, pressure 0-200#	250039-910	2
11	valve, solenoid 500 psi (II)	250030-164	1
12	locknut, conduit 1/2"	847200-050	1
13	bushing, conduit plastic 1/2"	847815-050	1
14	support, control box	02250046-914	1
15	nut, hex M6 x 1.0	825906-100	4
16	isolator, vibration 25MM OD x 10MM wide	02250046-958	2
17	conduit, flex 1"	846315-100	1.2 ft
18	wire, #8 black (varies with motor size)	850210-008	7.5 ft
19	valve, blowdown 1/4"	02250049-634	1
20	silencer, 1/4"	044916	1
21	bulkhead, pipe 1/4"	841500-004	1
22	gasket, panel	02250048-822	1
23	operator, push/pull	250028-588	1
24	contact, black	250027-125	1
25	starter, assembly	consult factory	1
26	connector, cord grip	250023-496	1
27	decal, super 2 (III)	02250073-285	1
28	foam, air regulator	02250052-482	1
29	grommet	02250047-178	2
30	spacer	02250047-177	2
31	capscrew, M6 x 20MM	829306-020	2

(Continued on page 55)

- (I)** For maintenance on pressure regular valve no. 250017-280, order repair kit no. 250019-453.
- (II)** For maintenance on valve no. 250030-164, order repair kit no. 250038-849 and replacement coil no. 250035-292.
- (III)** This item is included with panel control no. 02250071-542 (see key number 7 above).

PLEASE NOTE: WHEN ORDERING PARTS, INDICATE SERIAL NUMBER OF COMPRESSOR

ILLUSTRATIONS AND PARTS LIST

10.8 CONTROL BOX AND PARTS- SUPERVISOR II

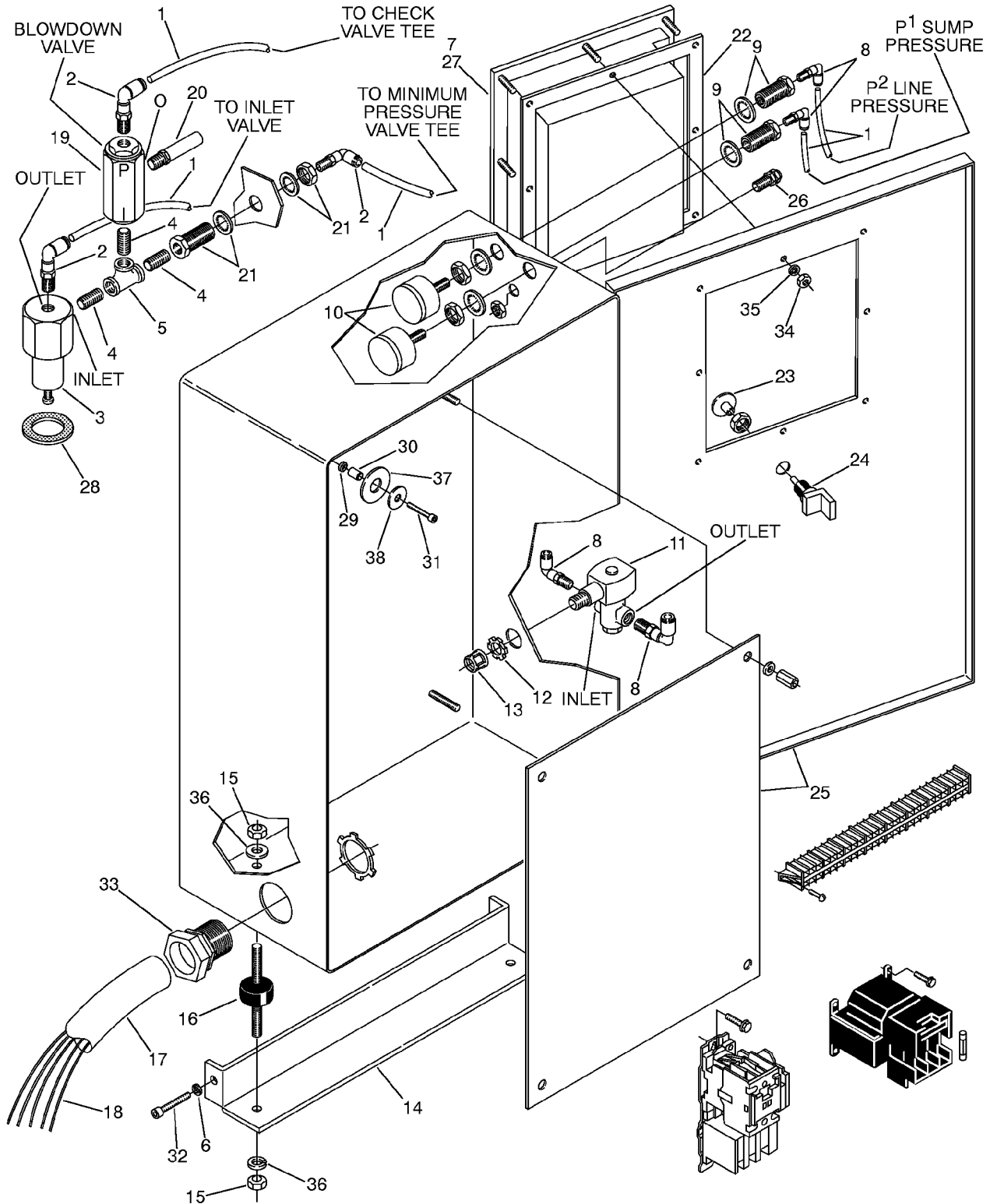

ILLUSTRATIONS AND PARTS LIST

10.8 CONTROL BOX AND PARTS- SUPERVISOR II (CONTINUED)

<i>key number</i>	<i>description</i>	<i>part number</i>	<i>quantity</i>
32	capscrew, socket M8 x 16MM	829308-016	2
33	connector, straight lq-tite	846400-100	1
34	nut, hex M4 x 0.7 (IV)	825904-070	8
35	washer, springlock M4 (IV)	838804-090	8
36	washer, springlock 6MM	838806-160	4
37	washer, pl xl ISO 7094-6-100HV	02250048-229	2
38	washer, ISO 7093-12-140HV	865712-370	2

(IV) This item is part of kit no. 02250051-535 and no. 02250051-536 (deluxe). To obtain this part please consult factory.

PLEASE NOTE: WHEN ORDERING PARTS, INDICATE SERIAL NUMBER OF COMPRESSOR

Section 10 ILLUSTRATIONS AND PARTS LIST

10.9 CONTROL BOX AND PARTS- ELECTRO-MECHANICAL

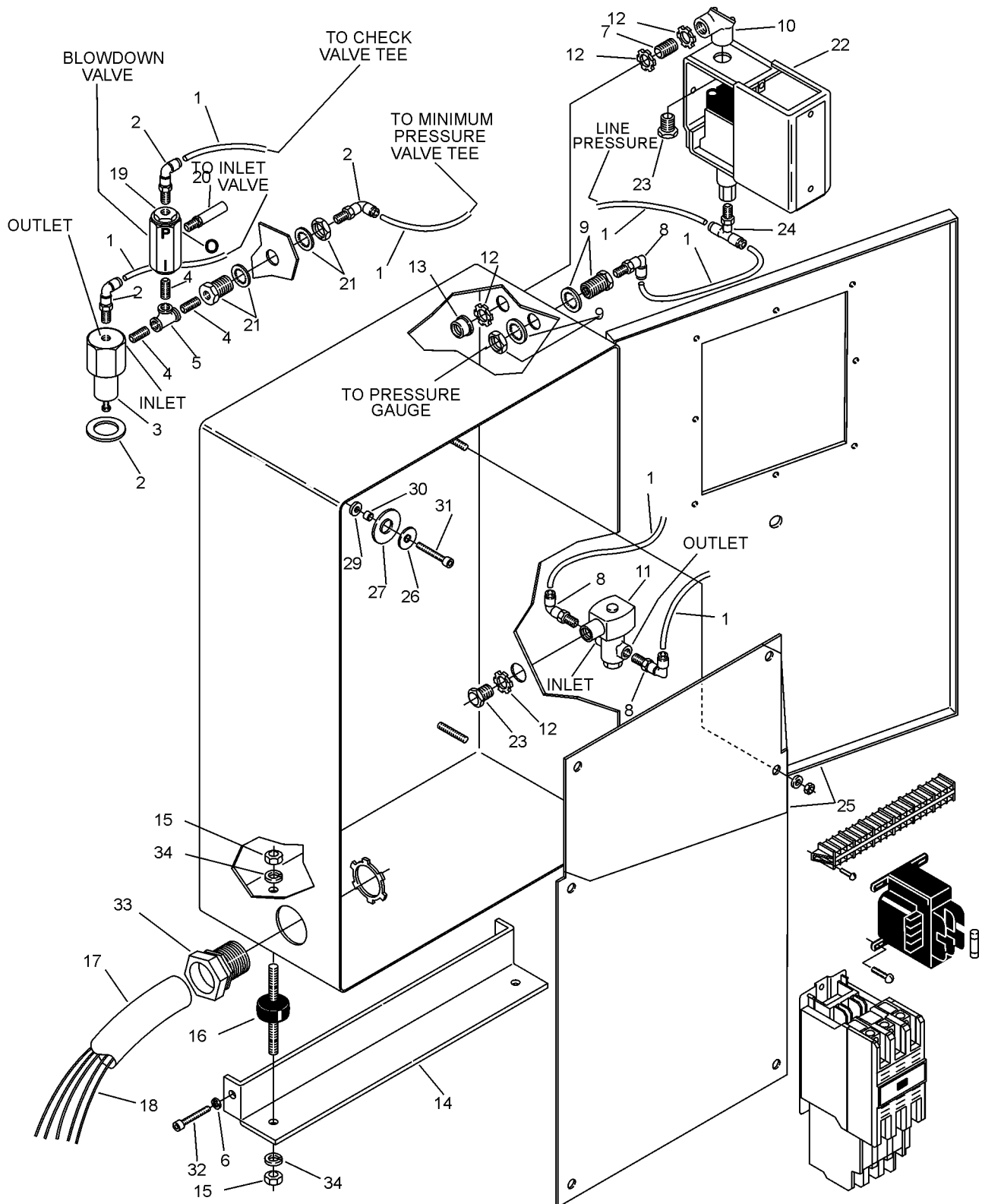

ILLUSTRATIONS AND PARTS LIST

10.9 CONTROL BOX AND PARTS- ELECTRO-MECHANICAL

<i>key number</i>	<i>description</i>	<i>part number</i>	<i>quantity</i>
1	hose, nylon 1/4"	842215-004	15 ft
2	elbow, 90_1/4" x 1/4"	250025-850	3
3	valve, pressure regulator	250017-280	1
4	nipple, pipe 1/4" x close	823204-015	3
5	tee, pipe 1/4"	804415-010	
6	washer, 8MM	865408-170	2
7	nipple, conduit		
8	elbow, 90_ 1/8" NPT x 1/4" tube	250025-849	4
9	bulkhead, pipe 1/8"	841500-002	2
10	elbow, corner pull 1/2"	846915-050	1
11	valve, solenoid 500 PSI	250030-164	1
12	locknut, conduit 1/2"	847200-050	1
13	bushing, conduit plastic 1/2"	847815-050	1
14	support, control box	02250046-914	1
15	nut, hex M6 x 1.0	825906-100	4
16	isolator, vibration 25MM OD x 10MM wide	02250046-958	2
17	conduit, flex 1"	846315-100	1.2 ft
18	wire, #8 black (varies with motor size)	850210-008	7.5
19	valve, blowdown 1/4"	02250049-655	1
20	silencer, 1/4"	044916	1
21	bulkhead, pipe 1/4"	841500-004	1
22	switch, pressure	040694	1
23	nipple, chase 1/2"	847815-050	1
24	tee, pipe galv	804415-010	1
25	starter, assembly	consult factory	1
26	washer	865712-370	2
27	washer	02250048-229	2
28	foam, air regulator	02250052-482	1
29	grommet	02250047-178	2
30	spacer	02250047-177	2
31	capscrew, M6 x 20MM	829306-020	2
32	capscrew, socket M8 x 16MM	829308-016	2
33	connector, straight lq-tite	846400-100	1
34	washer, springlock 6MM	838806-160	4

PLEASE NOTE: WHEN ORDERING PARTS, INDICATE SERIAL NUMBER OF COMPRESSOR

ILLUSTRATIONS AND PARTS LIST

10.10 INSTRUMENT PANEL - ELECTRO-MECHANICAL

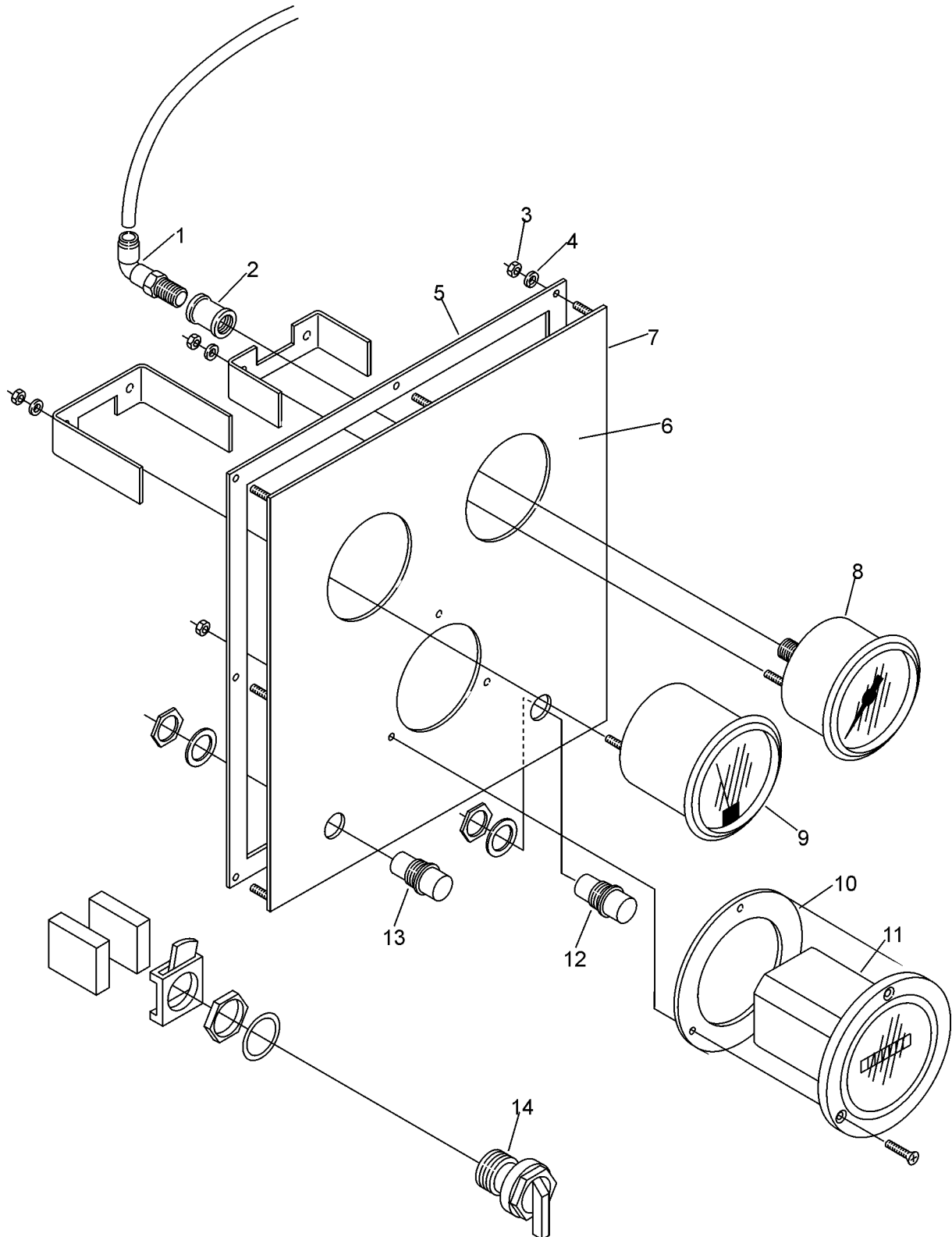

ILLUSTRATIONS AND PARTS LIST

10.10 INSTRUMENT PANEL - ELECTRO-MECHANICAL

<i>key number</i>	<i>description</i>	<i>part number</i>	<i>quantity</i>
1	elbow, 90_	250025-849	1
2	coupling, pipe 1/8"	803215-005	1
3	nut, hex metric M4 x .7	825904-070	8
4	washer, springlock M4	838804-090	8
5	gasket, panel	02250048-822	1
6	decal, panel	02250073-411	1
7	panel, instrument	02250069-058	1
8	gauge, pressure	250005-185	1
9	gauge, switch temperature	02250069-626	1
10	gasket, hourmeter	410353	1
11	hourmeter	042988	1
12	light, pilot assy green	250000-104	1
	Sholder, lamp	043383	1
	Slens, green	043385	1
	Sbulb	043386	1
	Sgasket, lamp holder	241808	1
	Sgasket, lens	241809	1
13	light, pilot assy red	250000-103	1
	Sholder, lamp	043383	1
	Slens, red	043384	1
	Sbulb	043386	1
	Sgasket, lamp holder	241808	1
	Sgasket, lens	241809	1
14	switch, selector 3 position	02250069-625	1

PLEASE NOTE: WHEN ORDERING PARTS, INDICATE SERIAL NUMBER OF COMPRESSOR

Section 10
ILLUSTRATIONS AND PARTS LIST

10.11 ENCLOSURE

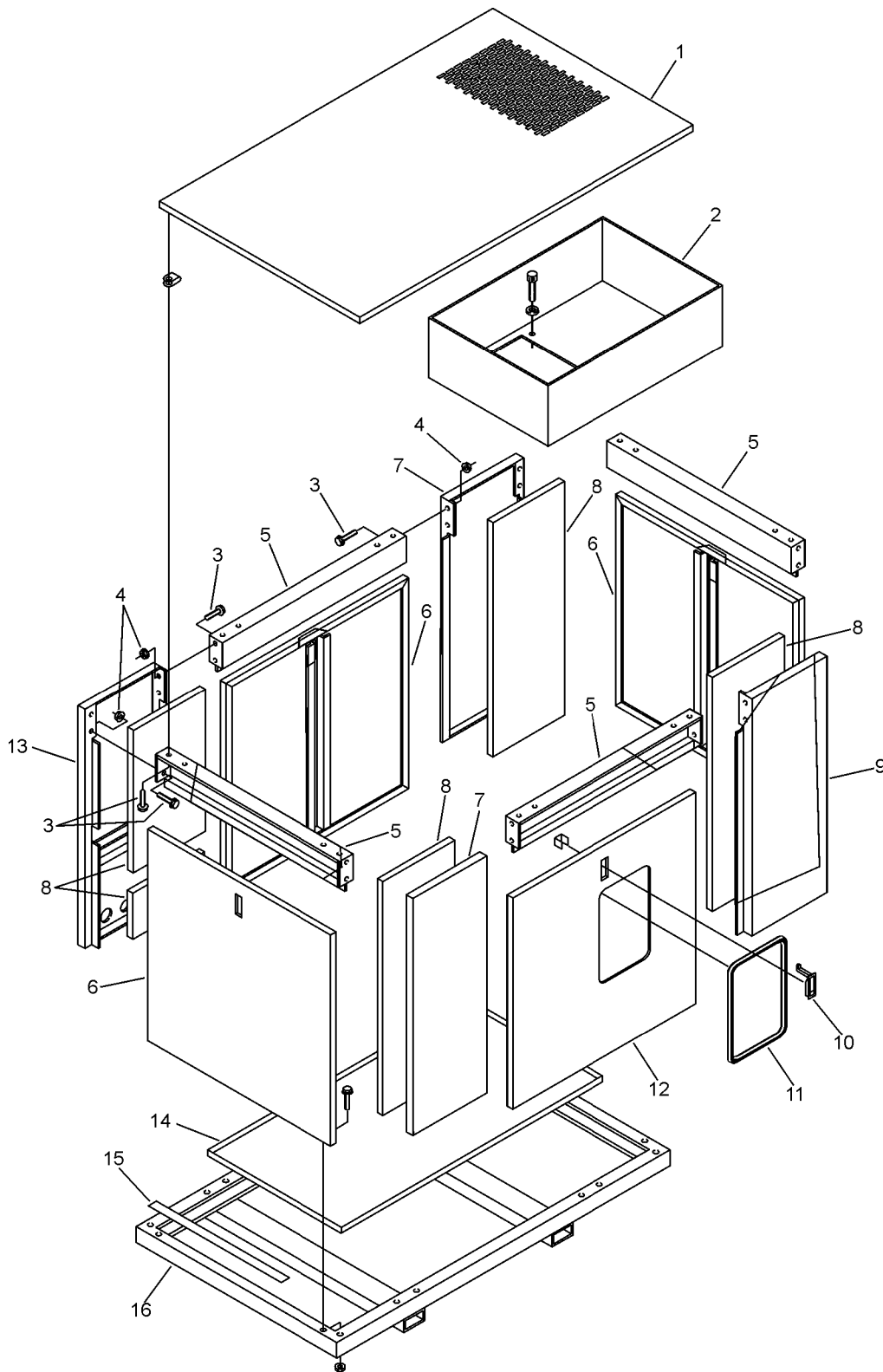

ILLUSTRATIONS AND PARTS LIST

10.11 ENCLOSURE

<i>key number</i>	<i>description</i>	<i>part number</i>	<i>quantity</i>
1	panel, roof assy	02250115-405	1
2	plenum	02250056-172	1
3	screw, hex ser washer 5/16"-18 x 3/4"	829705-075	55
4	nut, hex flgd 5/16"-18	825305-283	36
5	panel, center	224585	4
6	panel, door assy	02250100-067	3
7	panel, corner LH	224584	2
8	panel, fiberglass 13" x 36.5"	250020-059	3
9	panel, corner RH	224583	1
10	latch	049764	4
11	trim, canopy edge	250034-157	4 ft
12	panel, access control side assy	02250050-301	1
13	panel, assy	02250056-219	1
14	panel, oil drip (European only)	02250051-653	1
15	strip, weather 1" x 1/8"	02250058-345	50 ft
16	frame	014790	1
	Sframe	02250057-919	1

PLEASE NOTE: WHEN ORDERING PARTS, INDICATE SERIAL NUMBER OF COMPRESSOR

ILLUSTRATIONS AND PARTS LIST

10.12 DECAL GROUP

⚠ WARNING



Do not remove caps, plugs, or other components when compressor is running or pressurized.

Stop compressor and relieve all internal pressure before doing so.

049685

1

⚠ DANGER



Lethal shock hazard inside.

Disconnect all power at source, before opening or servicing.

44630

2

⚠ WARNING



Hot surfaces.

To avoid burns, keep hands and all parts of the body away.

487408

3

⚠ DANGER



Death or serious injury can occur from inhaling compressed air without using proper safety equipment. See OSHA standards on safety equipment.

250027-825

5

⚠ WARNING



Do not permit air from this equipment to contact food stuff except in full compliance with FDA Standard 21CFR178.3570, and all other applicable federal, state and local, codes, standards and regulations.

250003-144

6

CAUTION: This machine is equipped with Automatic Stop/Start Control System.

DO NOT ATTEMPT to make any adjustment without disconnecting both main line and control circuit electrical power.

041085

4

← DIRECTION OF ROTATION

49745

7

ILLUSTRATIONS AND PARTS LIST

10.12 DE CAL GROUP

<i>key number</i>	<i>description</i>	<i>part number</i>	<i>quantity</i>
1	sign, warning - compressor fluid fill cap	049685	1
2	sign, danger electrocution	049850	1
3	sign, warning - hot surfaces	407408	1
4	decal, warning auto start	041065	1
5	decal, danger breath air	250027-935	1
6	sign, warning "food grade" lube	250003-144	1
7	decal, rotation direction	040745	1

(Continued on page 65)

PLEASE NOTE: WHEN ORDERING PARTS, INDICATE SERIAL NUMBER OF COMPRESSOR

ILLUSTRATIONS AND PARTS LIST

10.12 DECAL GROUP

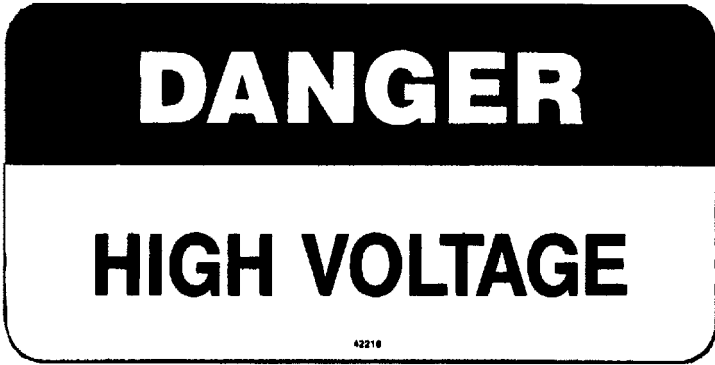
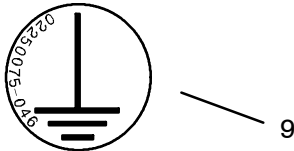
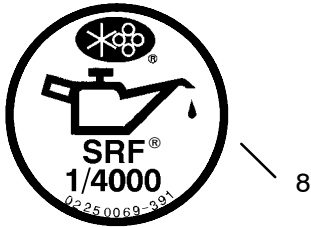

Use equipment grounding connector in accordance with the National Electrical Code, and all Federal State, and Local Codes, to help avoid possible ground fault shock hazard.

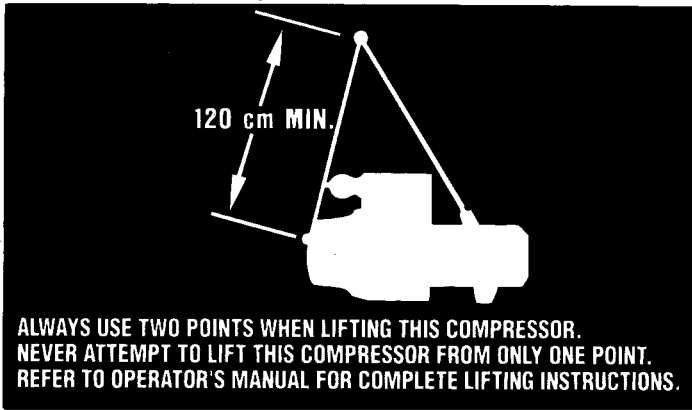

02250055-510

ILLUSTRATIONS AND PARTS LIST

10.12 DECAL GROUP (CONTINUED)

<i>key number</i>	<i>description</i>	<i>part number</i>	<i>quantity</i>
8	decal, compressor fluid SRF 1/4000 (I)	02250069-391	1
9	decal, earth ground	02250075-046	2
	Sdecal, protective earth ground (not shown)	02250075-045	1
	Sdecal, PE designation (not shown)	02250075-540	1
10	decal, danger hi voltage	042218	1
11	sign, warning ground fault	049852	1
12	decal, ISO 9001	02250059-288	1
13	decal, warning lift	02250055-510	1

(Continued on page 67)

(I) Decal will change with fluid requirement.

PLEASE NOTE: WHEN ORDERING PARTS, INDICATE SERIAL NUMBER OF COMPRESSOR

Section 10
ILLUSTRATIONS AND PARTS LIST

10.12 DECAL GROUP

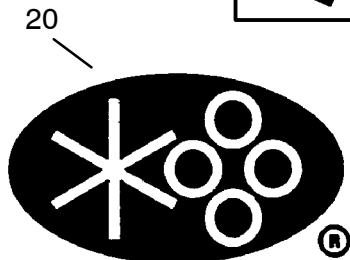
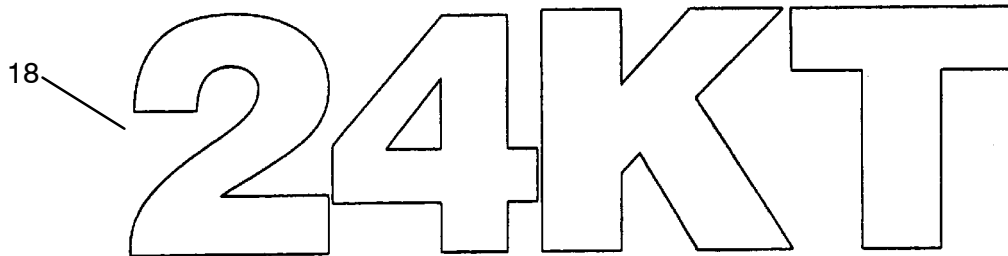
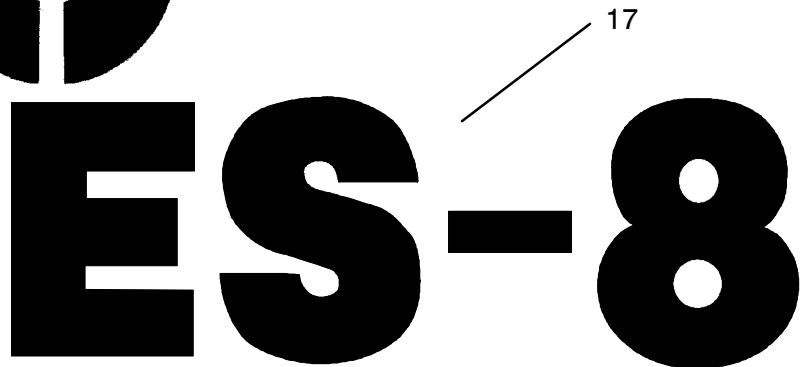
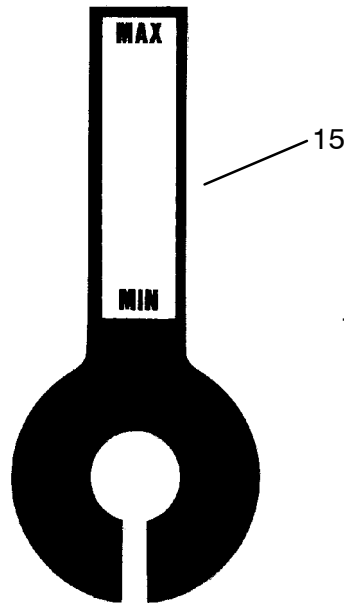
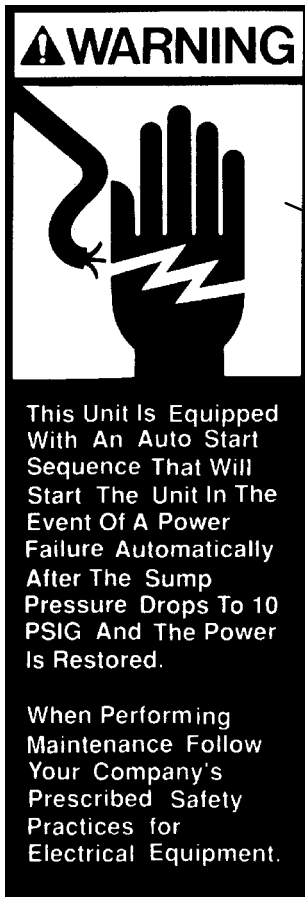

ILLUSTRATIONS AND PARTS LIST

10.12 DECAL GROUP (CONTINUED)

<i>key number</i>	<i>description</i>	<i>part number</i>	<i>quantity</i>
14	decal, warning auto start	250017-903	1
	Sdecal, ES-8 Supervisor II dlx info (not shown)	02250073-940	1
15	decal, fluid level E8E	02250046-871	1
16	decal, warning mixing fluids	02250110-891	1
17	decal, ES-8 black 3.5" high	02250059-138	1
18	decal, 24KT 2.5" (I)	02250061-016	1
j 19	decal, lift (II)	241214	2
20	decal, Sullair 2 1/4" x 18" black	02250059-052	1
	Sdecal, Sullair 3 1/2" x 28" black (encl)	02250059-058	1
20	decal, ES-8 Supervisor II front (see Figure 5-1 in Operator's Section)	02250073-285	1
21	decal, ES-8 Supervisor II std info (not shown)	02250073-939	1

(I) Used only on 24KT compressors.

(II) Used on enclosed models.

PLEASE NOTE: WHEN ORDERING PARTS, INDICATE SERIAL NUMBER OF COMPRESSOR

Section 10 ILLUSTRATIONS AND PARTS LIST

10.13 DECAL LOCATIONS

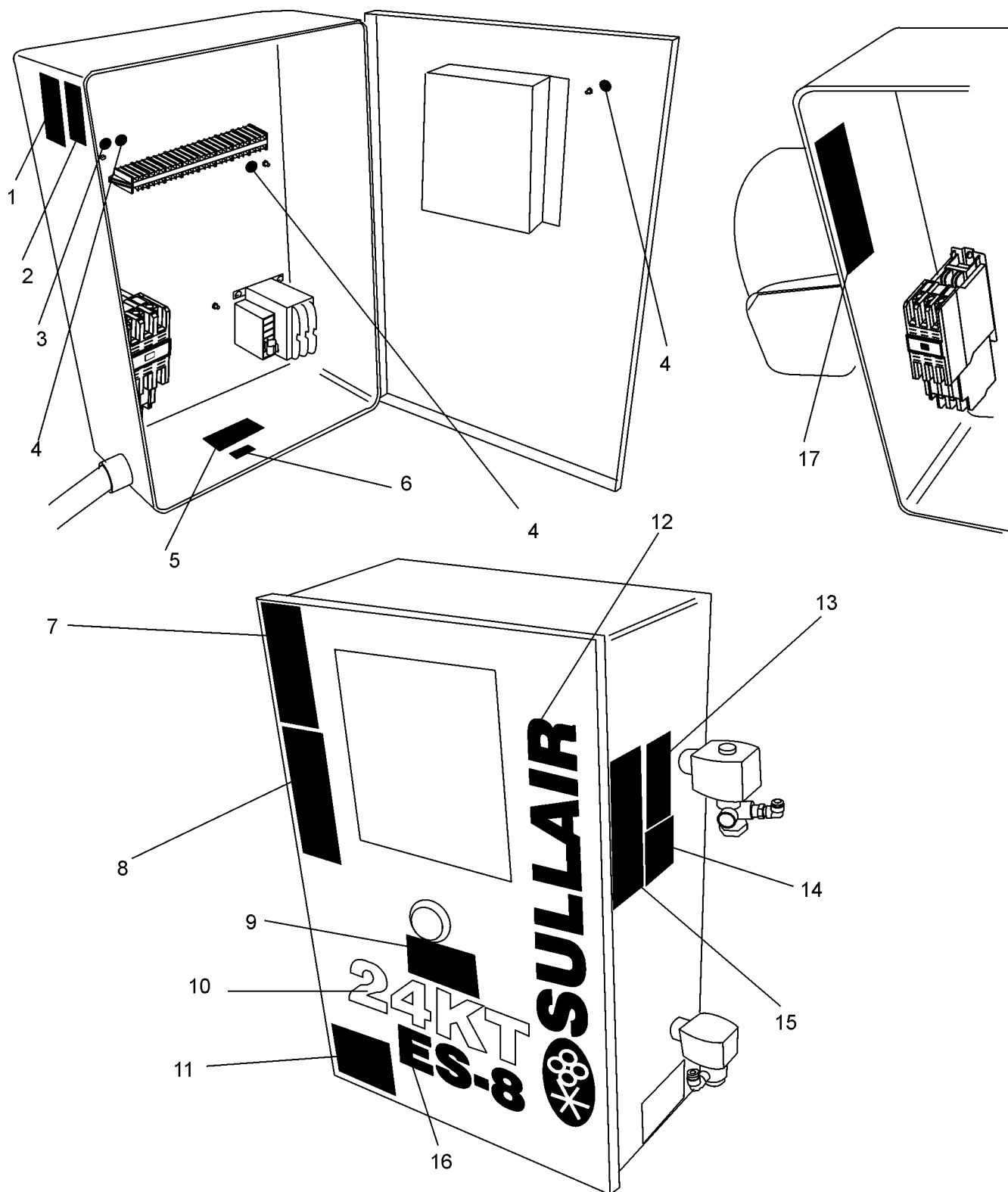

ILLUSTRATIONS AND PARTS LIST

10.13 DECAL LOCATIONS (CONTINUED)

<i>key number</i>	<i>description</i>	<i>part number</i>	<i>quantity</i>
1	sign, warning "food grade" lube	250003-144	1
2	decal, danger breath air	250027-935	1
3	decal, PE designation	02250075-540	1
4	decal, earth ground	02250075-046	2
5	decal, danger hi voltage	042218	1
6	decal, compressor fluid SRF 1/4000 (I)	02250069-391	1
7	sign, danger electrocution	049850	1
8	decal, warning auto start	250017-903	1
9	decal, warning auto start	041065	1
10	decal, 24KT black 2.5" (II)	02250061-016	1
11	decal, warning 8E lift	02250055-510	1
12	decal, Sullair 2 1/4" x 18" black	02250059-052	1
13	sign, warning - hot surfaces	407408	1
14	decal, warning mixing fluids (III)	02250110-891	1
15	sign, warning - compressor fluid fill cap	049685	1
16	decal, ES-8 black 3.5" high	02250059-138	1
17	sign, warning ground fault	049852	1

(I) Compressor fluids may vary. Consult Sullair to verify the fluid of your compressor if you do not know the fluid type.

(II) Decal used for 24KT fluid machines only.

(III) Decal is placed at this location for standard machine. For closed inlet machines, consult key no. 18 of this section.

PLEASE NOTE: WHEN ORDERING PARTS, INDICATE SERIAL NUMBER OF COMPRESSOR

ILLUSTRATIONS AND PARTS LIST

10.13 DECAL LOCATIONS

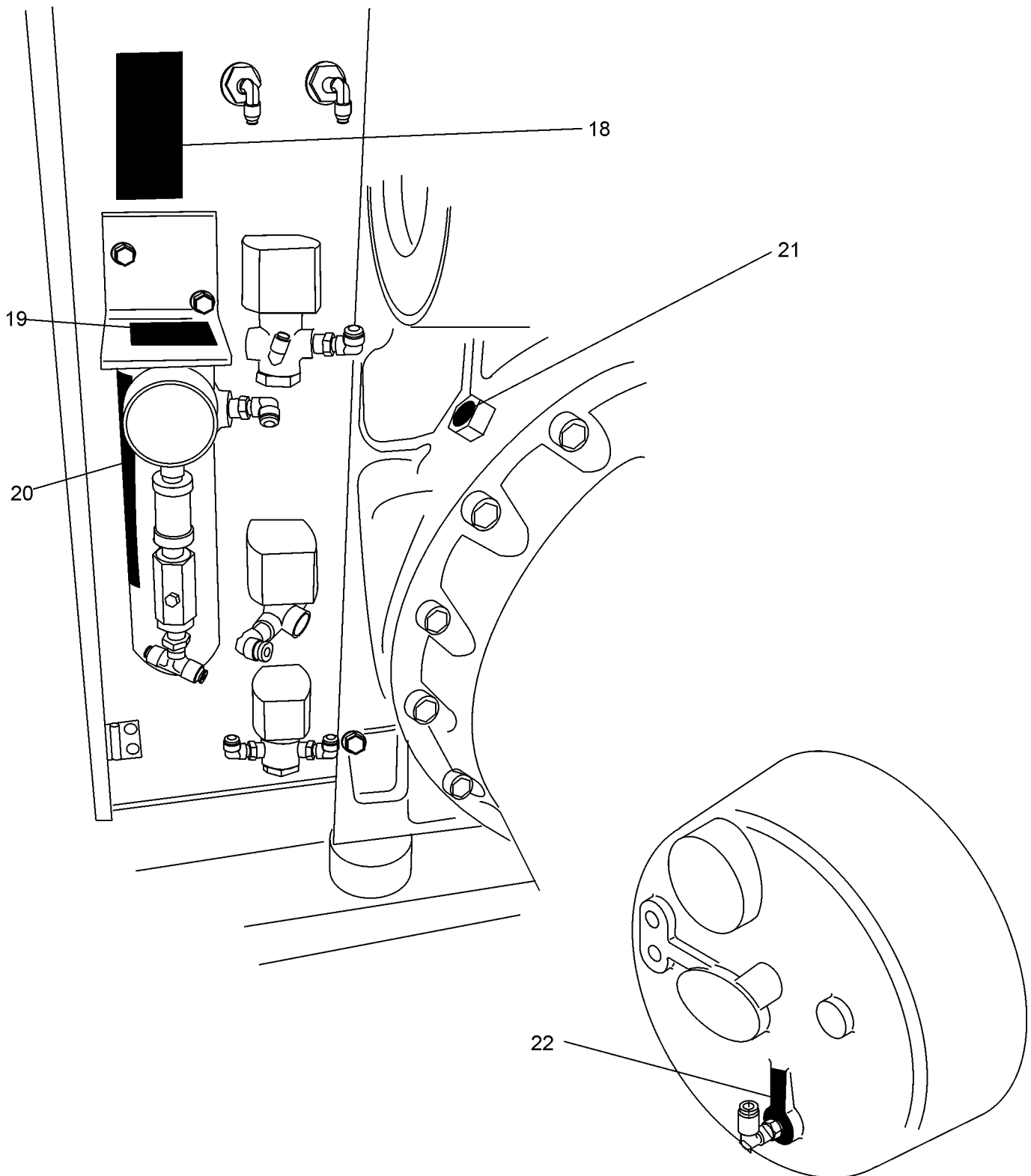

ILLUSTRATIONS AND PARTS LIST

10.13 DECAL LOCATIONS (CONTINUED)

<i>key number</i>	<i>description</i>	<i>part number</i>	<i>quantity</i>
18	sign, warning - hot surfaces	407408	1
19	decal, warning mixing fluids (IV)	02250110-891	1
20	sign, warning - compressor fluid fill cap	049685	1
21	decal, compressor fluid SRF 1/4000 (V)	02250069-391	1
22	decal, fluid leve E8E	02250046-871	1

(IV) Decal is placed at this location for closed inlet machine. For standard machines, consult key no. 14 of this section.

(V) Compressor fluids may vary. Consult Sullair Corporation to verify the fluid fill of your compressor if you do not know the fluid type.

PLEASE NOTE: WHEN ORDERING PARTS, INDICATE SERIAL NUMBER OF COMPRESSOR

ILLUSTRATIONS AND PARTS LIST

10.14 DECAL LOCATIONS- ENCLOSURE

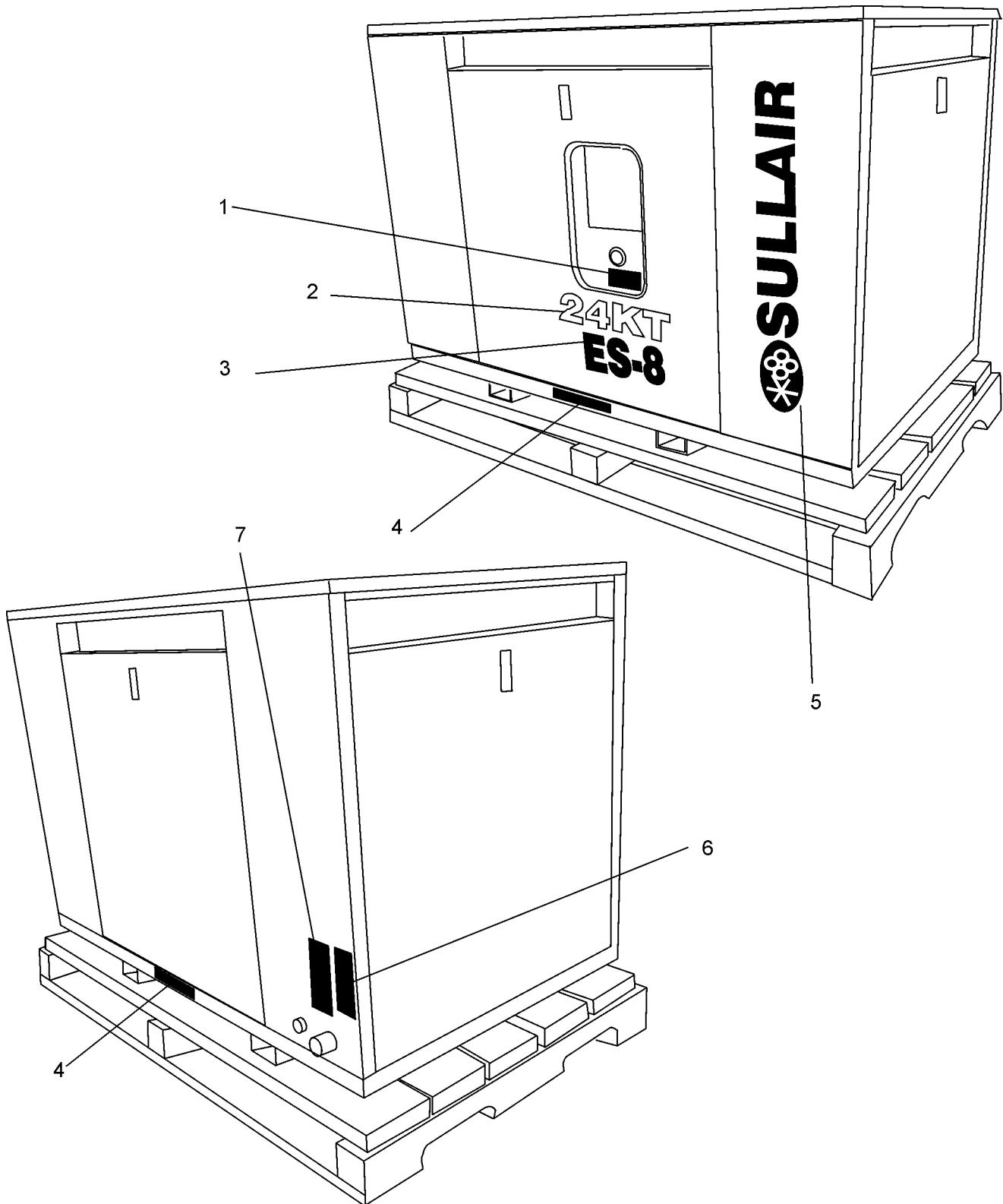

ILLUSTRATIONS AND PARTS LIST

10.14 DECAL LOCATIONS- ENCLOSURE

<i>key number</i>	<i>description</i>	<i>part number</i>	<i>quantity</i>
1	decal, warning auto start	041065	1
2	decal, 24KT black 2.5" (I)	02250061-016	1
3	decal, ES-8 black 3.5" high	02250059-138	1
4	decal, fork lifting	241814	2
5	decal, Sullair 3 1/2" x 28" black (encl)	02250059-058	1
6	decal, danger breath air	250027-935	1
7	sign, warning "food grade" lube	250003-144	1

(I) Decal used for 24KT fluid machines only.

PLEASE NOTE: WHEN ORDERING PARTS, INDICATE SERIAL NUMBER OF COMPRESSOR

ILLUSTRATIONS AND PARTS LIST

10.15 WIRING DIAGRAM - FULL VOLTAGE ELECTRO-MECHANICAL

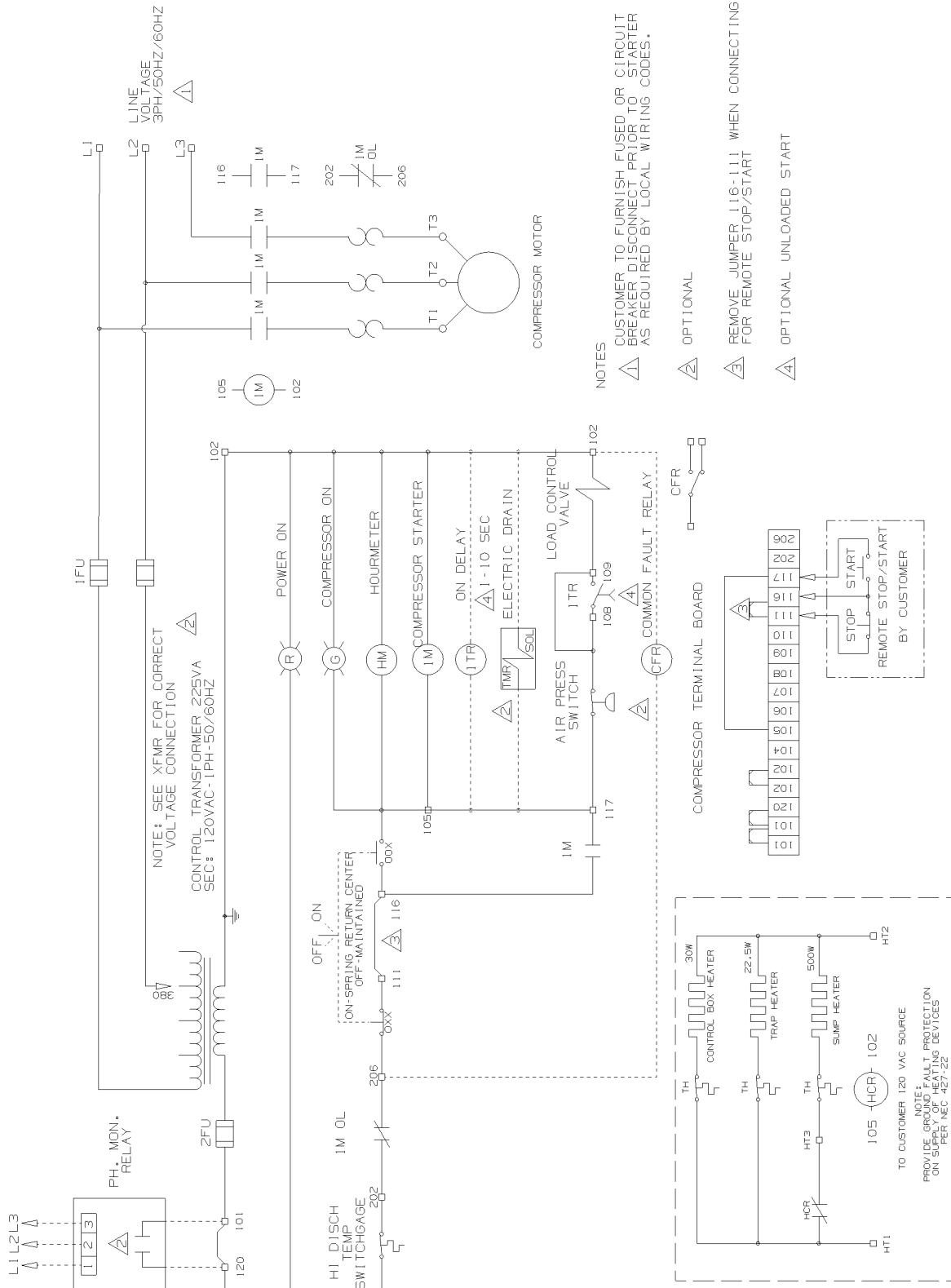

10.16 WIRING DIAGRAM -FULL VOLTAGE SUPERVISOR II

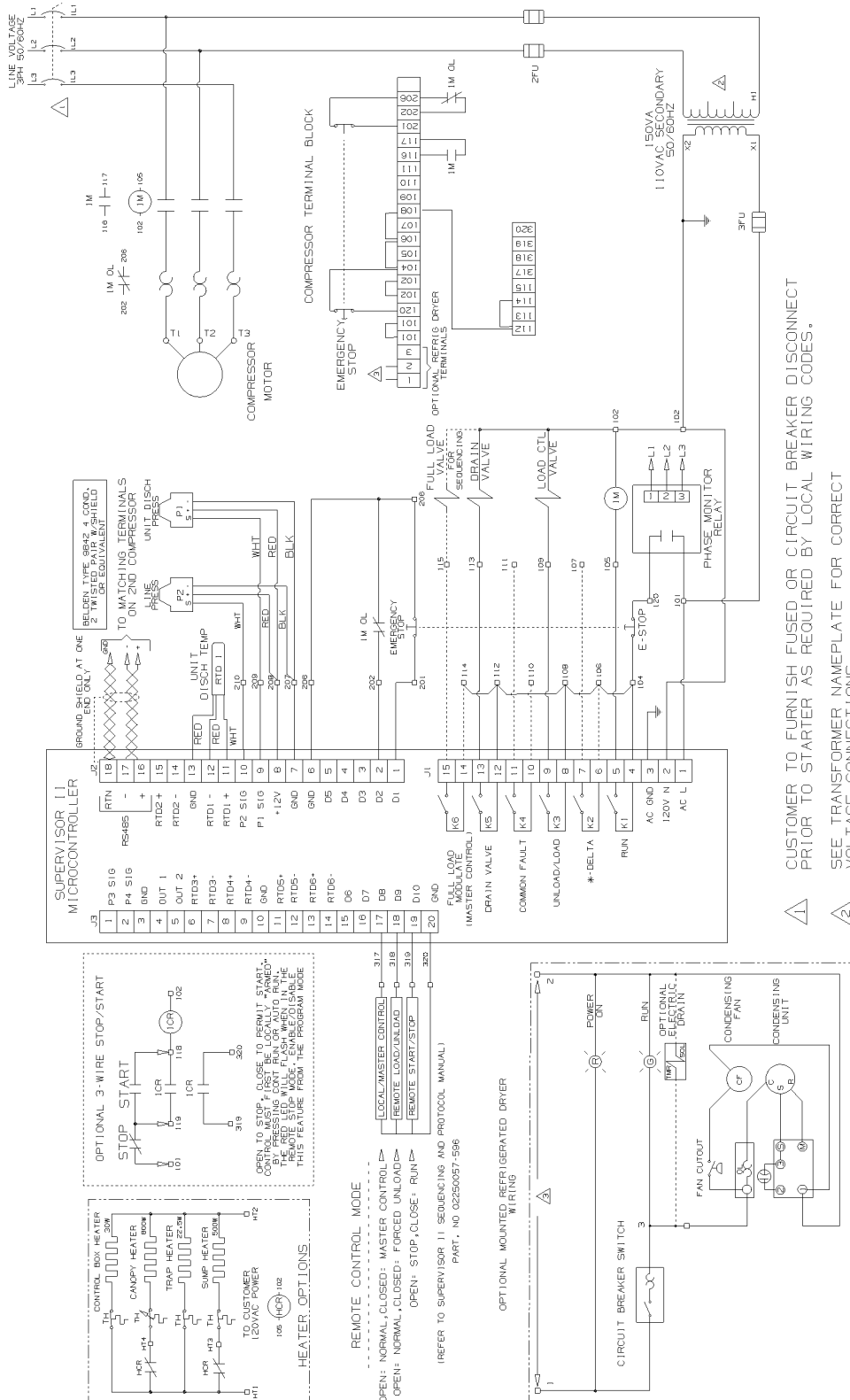

⚠ CUSTOMER TO FURNISH FUSED OR CIRCUIT BREAKER DISCONNECT PRIOR TO STARTER AS REQUIRED BY LOCAL WIRING CODES.

⚠ SEE TRANSFORMER NAMEPLATE FOR CORRECT VOLTAGE CONNECTIONS

⚠ CUSTOMER SUPPLIED 115/120V CONTROL POWER FOR MOUNTED REFRIGERATED DRYER PACKAGE DO NOT CONNECT TO T01-T02. MINIMUM CIRCUIT AMPACITY 12 AMPS.

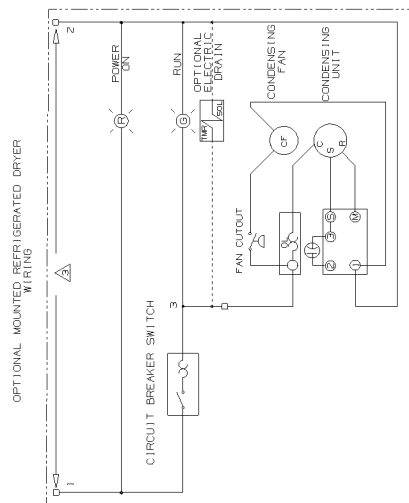
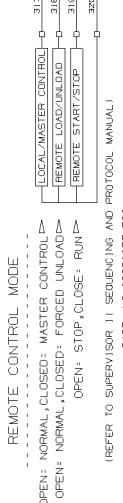
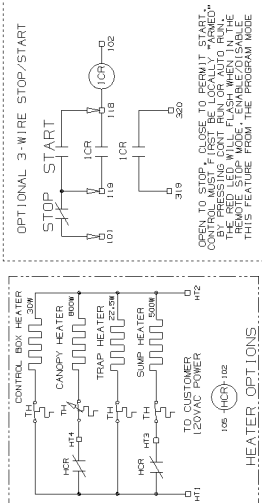

ILLUSTRATIONS AND PARTS LIST

10.17 WIRING DIAGRAM - WYE DELTA ELECTRO-MECHANICAL

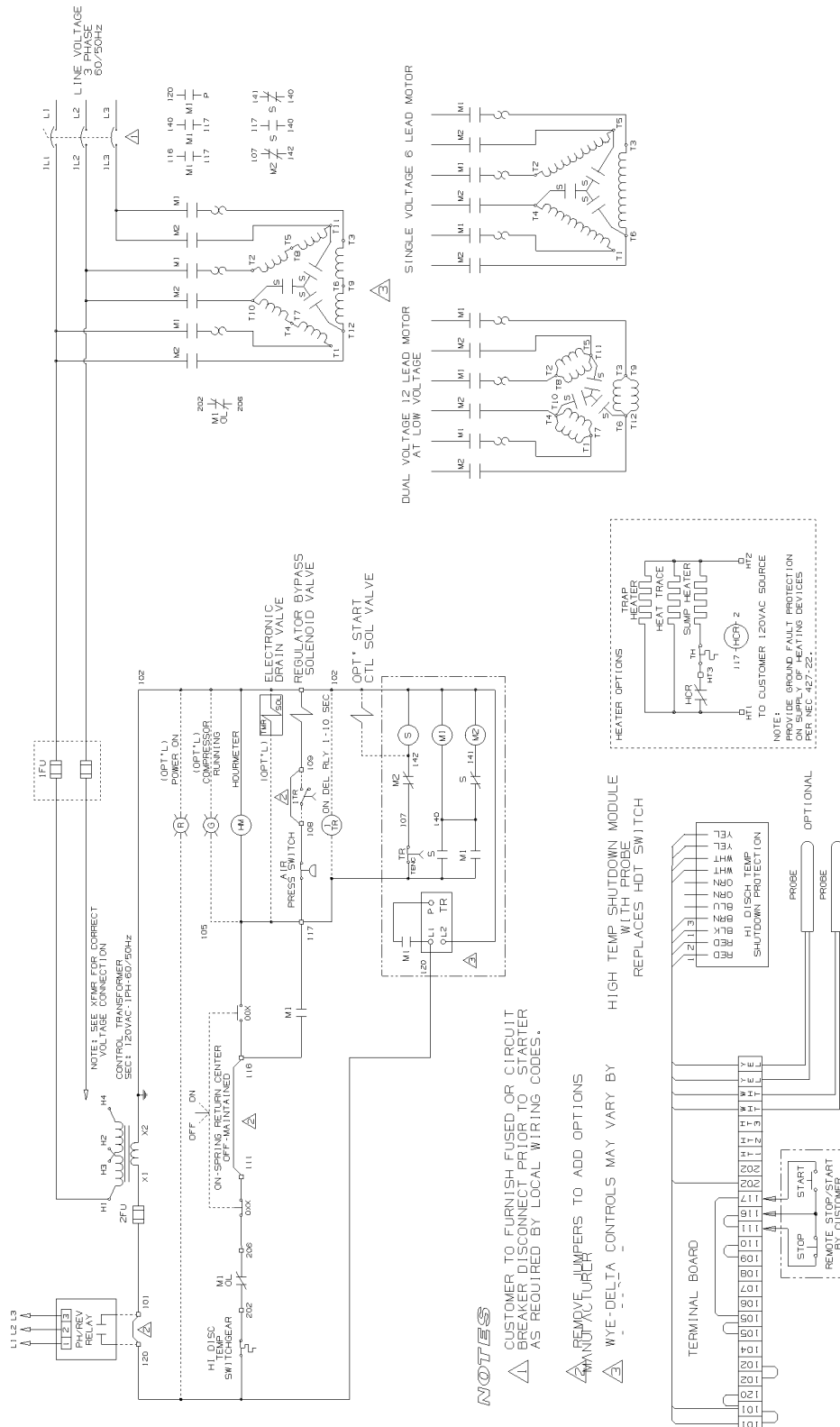

10.18 WIRING DIAGRAM - WYE DELTA SUPERVISOR II

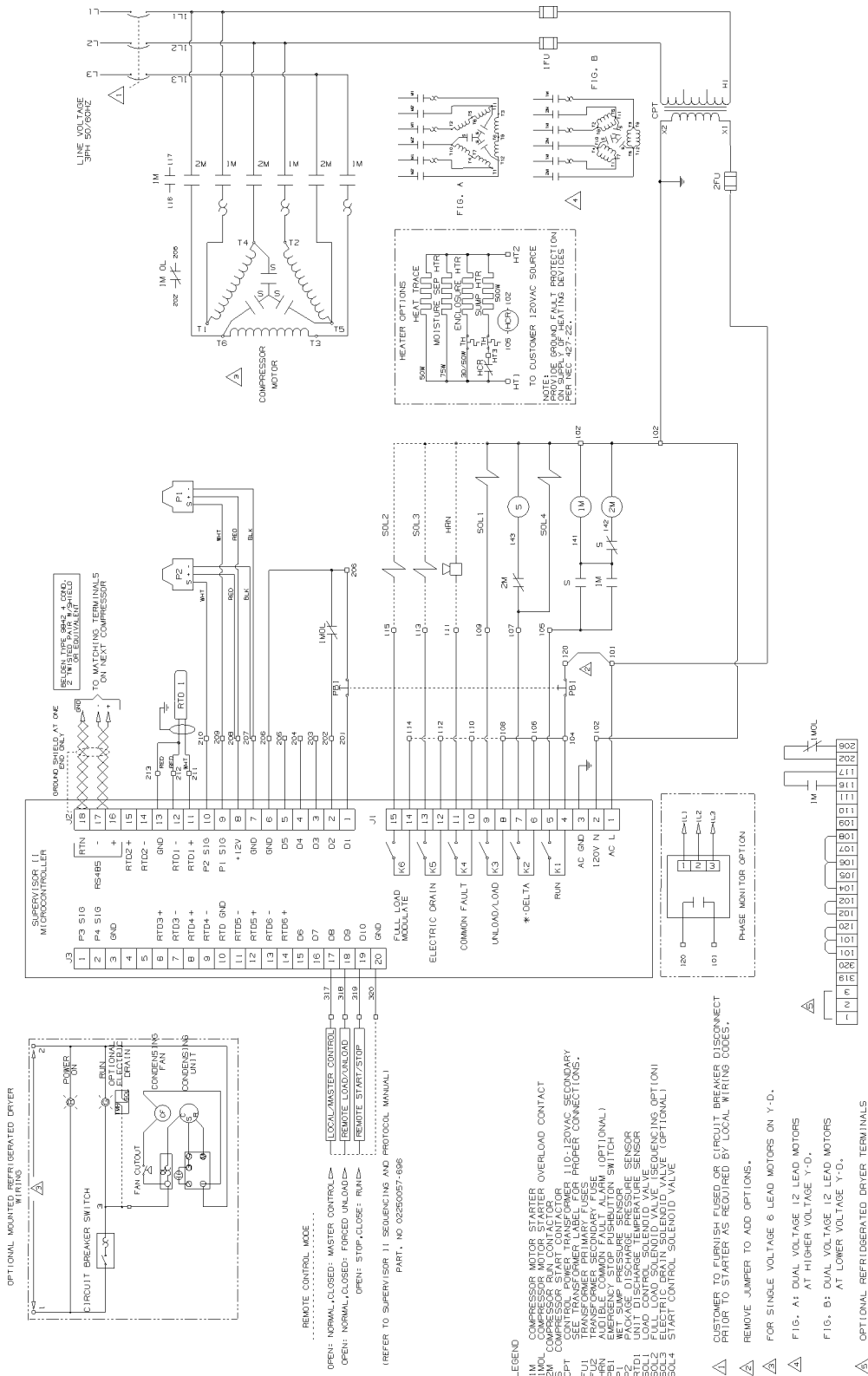

NOTES

WORLDWIDE SALES AND SERVICE

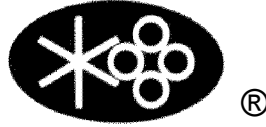

SULLAIR ASIA, LTD.
Sullair Road, No. 1
Chiwan, Shekou
Shenzhen, Guangdong PRV.
PRC POST CODE 518068
Telephone: 755-6851686
Fax: 755-6853473

SULLAIR EUROPE, S.A.
Zone Des Granges BP 82
42602 Montbrison Cedex, France
Telephone: 33-477968470
Fax: 33-477968499

SULLAIR CORPORATION
3700 East Michigan Boulevard
Michigan City, Indiana 46360 U.S.A.
Telephone: 1-219-879-5451
Fax: (219) 874-1273
Fax: (219) 874-1835 (Parts)
Fax: (219) 874-1288 (Service)



Printed in U.S.A.

Specifications Subject To
Change Without Prior Notice
E00EPS