

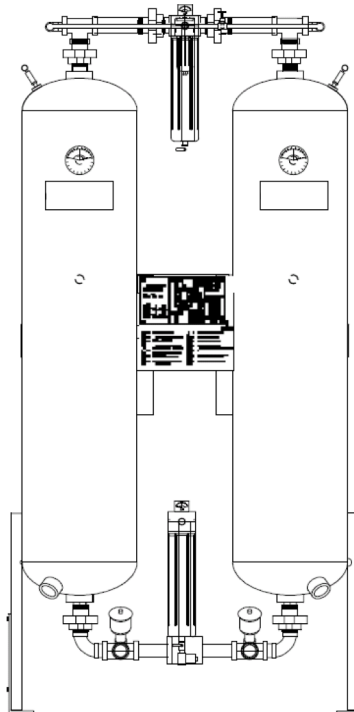

Always air. Always there.

USER/SERVICE MANUAL

DESICCANT HEATLESS REGENERATIVE COMPRESSED AIR DRYERS DHL-80 TO DHL-5000



WARRANTY NOTICE

Failure to follow the instructions
and procedures in this manual or,
misuse of this equipment will
VOID its warranty!

PART NUMBER:

02250195-403 R00

**KEEP FOR
FUTURE
REFERENCE**

©SULLAIR CORPORATION

The information in this manual is current
as of its publication date, and applies to
compressor serial number:

SHDIDFAA-0001

and all subsequent serial numbers.



AIR CARE SEMINAR TRAINING

Sullair Air Care Seminars are courses that provide hands-on instruction for the proper operation, maintenance, and servicing of Sullair products. Individual seminars on Industrial compressors and compressor electrical systems are offered at regular intervals throughout the year at Sullair's corporate headquarters training facility located at Michigan City, Indiana.

Instruction includes training on the function and installation of Sullair service parts, troubleshooting common faults and malfunctions, and actual equipment operation. These seminars are recommended for maintenance, contractor maintenance, and service personnel.

For detailed course outlines, schedule, and cost information contact:

SULLAIR TRAINING DEPARTMENT

1-888-SULLAIR or
219-879-5451 (ext. 5623)
www.sullair.com
training@sullair.com

- Or Write -

Sullair Corporation
3700 E. Michigan Blvd.
Michigan City, IN 46360
Attn: Service Training Department.



TABLE OF CONTENTS

SECTION 1—INTRODUCTION

5	1.1	IDENTIFICATION PLATE
5	1.2	WARRANTY CONDITIONS

SECTION 2—SAFETY

7	2.1	SAFETY INFORMATION
8	2.2	DEFINITION OF THE SAFETY SYMBOLS USED
10	2.3	WARNINGS
10	2.4	PROPER USE OF THE DRYER
11	2.5	INSTRUCTIONS FOR THE USE OF PRESSURE EQUIPMENT

SECTION 3—INSTALLATION

13	3.1	TRANSPORT
13	3.2	INSTALLATION SITE
14	3.3	INSTALLATION LAYOUT
15	3.4	OPERATING CONDITIONS
15	3.5	CONNECTION TO THE COMPRESSED AIR SYSTEM
15	3.6	CONNECTION TO THE ELECTRICAL SUPPLY
15	3.7	INLET FILTER CONDENSATE DRAIN

SECTION 4—STARTUP

17	4.1	PRELIMINARY OPERATION
17	4.2	FIRST START-UP
18	4.3	OPERATION AND SWITCHING OFF

SECTION 5—TECHNICAL SPECIFICATIONS

SECTION 6—TECHNICAL DESCRIPTION

21	6.1	CONTROL PANEL
21	6.2	DESCRIPTION OF OPERATION
23	6.3	OPERATION
23	6.4	PURGE METERING VALVE SETTINGS

TABLE OF CONTENTS

25	6.5	CYCLE DESCRIPTION
27	6.6	CONTROL PANEL
30	6.7	OPERATION CONFIGURATION
32	6.8	POWER SELECTOR
32	6.9	DIP-SWITCHES
34	6.10	OPERATING CYCLES
37	6.11	TEST
38	6.12	MAINTENANCE (SERVICE)
38	6.13	FUSES
38	6.14	DEWPOINT METER— (OPTIONAL)
39	6.15	PDP ANALOG SIGNAL
40	6.16	PRESSURE SWITCHES OF “FAIL TO SWITCH ALARM”— (OPTIONAL)
41	6.17	CALIBRATION PRESSURES

SECTION 7—MAINTENANCE, TROUBLESHOOTING, SPARES AND DISMANTLING

43	7.1	CONTROLS AND MAINTENANCE
44	7.2	TROUBLESHOOTING
46	7.3	DISMANTLING OF THE DRYER

SECTION 8—ATTACHMENTS

48	8.1	ID—DHL80-125
50	8.2	ID—DHL150-200
52	8.3	ID—DHL250-300
54	8.4	ID—DHL400-600
56	8.5	ID—DHL800-1000
58	8.6	ID—DHL1250-1500
60	8.7	ID—DHL2000
62	8.8	ID—DHL2500-3000
64	8.9	ID—DHL3500-4000
66	8.10	ID—DHL4000-5000
68	8.11	P&I—DHL80-125
70	8.12	WD—DHL80-5000
72	8.13	SPARE PARTS LIST

Section 1

INTRODUCTION

Thank you for choosing our product. In order to get the best performances from this product, please read this manual carefully. To avoid damage to the equipment and physical risk to the operator, please read and strictly follow the instructions contained in this manual. Note, these instructions are in addition to the Local and Federal safety rules that apply where the dryer is installed.

Before packing for shipment each DHL series heatless adsorption air dryer is subjected to rigorous testing to demonstrate that the device can perform all the functions for which it has been designed.

Once the dryer has been properly installed according to the instructions in this manual, it will be ready for use without any further adjustment. The operation is fully automatic, and the maintenance must be performed regularly, as detailed in the following chapters.

This manual should be kept available for future reference and is intended to be an important tool in the proper operation and maintenance of the dryer.

Due to the continuous technical evolution, we reserve the right to introduce any necessary change without giving previous notice.

Should you experience any trouble, or for further information, please do not hesitate to contact us.

Model	
Serial No.	
Code	Heatless Regenerative Dryer
Nominal Flow Rate	SCFM
Max. Air Pressure	150 PSIG
Max. Inlet Air Temperature	100°F
Ambient Temperature	100°F
Dessicant (type and Qty)	Activated Alumina
Electric Supply	115/110/1/50,60 208/220/1/50,60
Electric Nominal Power	10W
Fuse Max.	1 AMP
Manufactured	—

1.1 IDENTIFICATION PLATE

The product identification plate shows all the primary data of the machine. Upon installation, fill in the table shown on the side copying the data shown on the identification plate. Refer to this data when ordering parts or requesting service, even during the warranty period.

Removal or alteration of the identification plate will void the warranty

1.2 WARRANTY CONDITIONS

For 12 months from the installation date, but no longer than 18 months from the delivery date, the warranty covers eventual faulty parts, which will be repaired or replaced free of charge.

The warranty doesn't cover any responsibility for direct or indirect damages to persons, animals or equipment caused by improper usage or maintenance, and it's limited to manufacturing faults only.

The right to warranty repairs is subordinated to the strict compliance with the installation, use and maintenance instructions contained in this manual.

To request repairs during the warranty period, the data reported on the identification plate must be notified.

The warranty will be immediately voided in case of even small changes or alterations to the dryer.

<i>Table 1-1: Dryer Specifications</i>	
IT IS RECOMMENDED TO FILL OUT THIS SECTION AT INITIAL START UP OF THE DRYER.	
Model No. _____	Desiccant/Tower: _____ LBS _____
Serial No. _____	Inlet/Outlet Size: _____ NPT _____
Inlet Design Conditions: _____	Cycle Time: _____ Standard Short Cycle _____
Flow: _____ SCFM@	
Pressure: _____ 100 _____ PSIG	Maximum Operating Pressure: _____ PSIG
Temperature: _____ 100 _____ °F	Minimum Operating Pressure: _____ PSIG
Outlet Dew Point: _____ °F PDP @ Above Conditions	Maximum Operating Temperature: _____ °F
Purge Flow: _____ PSIG/SCFM _____	Minimum Operating Temperature: _____ °F
Power Supply: _____ V _____ PH _____ HZ	
Current Draw: _____ AMP _____	
<ol style="list-style-type: none"> 1. This pressure is 95% of MAWP 2. Operating at "OFF" design conditions may adversely affect Outlet Dew Point. 3. Operation of dryer below 35°F requires heat tracing of certain components upstream of dryer outlet. 	

Section 2

SAFETY

The dryer has been designed and constructed in accordance with the generally recognized rules pertaining to adsorption technology as well as industrial safety and accident prevention regulations.

The equipment design, development, production, assembly and customer service fall under the **Sullair** quality control system.

The dryer is state of the art. There are, however, hazards to the body, equipment and life accompanying this type of product if it is not operated for the purpose which it is intended by trained and specialized personnel.

The equipment supplied is intended exclusively for drying compressed air. Any other use or one exceeding this is considered unauthorized. **Sullair** cannot be held liable for damages resulting from incorrect or unauthorized use of the equipment. Any such risk is carried solely by the end user.

Authorized use means complete compliance with all of the conditions of operation, servicing and maintenance prescribed by **Sullair** in this Instruction and Operation Manual.

The dryer is only to be operated, serviced and repaired by trained personnel who are familiar with this type of equipment and understand fully its operation and any potential dangers.

2.1 SAFETY INFORMATION

The end user and operator must observe all National, State, and Local industrial and safety regulations dealing with the operation of pressure vessels under compressed air service. Also all “end user” safety rules for the same type of service must be adhered to. The following points list some of the important factors dealing with this type of equipment.











- Never make any structural changes to the equipment
- Use only original spare parts and accessories
- Never weld on any pressure vessel or modify it in any way
- All maintenance on “pressure parts” must be carried out with the equipment shut-down, depressurized and locked out. Any in plant procedures or work permits regarding pressure vessels are to be adhered to.
- Do not operate the equipment with the control panel door open, the electrical system energized and live parts exposed.
- Disconnect the dryer from the electrical supply when any electrical work is performed. Lock out the safety disconnect and obtain any required work permits.







The desiccants used in this equipment are not considered hazardous. However **all contact with or disposal of the desiccant** should be in accordance with the **relevant MSDS**. The following lists the more common safety measures normally observed during filling operations.

- In the case of accidental contact of the desiccant with the eyes, rinse immediately with an abundance of clean water. **Refer to the MSDS.**
- Accidental spillage of desiccant on the floor should be cleaned up avoiding the creation of excess dust during this procedure.
- Use a contoured face mask during any filling or draining operations. **Refer to the MSDS.**





NOTES

2.2 DEFINITION OF THE SAFETY SYMBOLS USED

	Before attempting any intervention on the dryer, read carefully the instructions reported in this use and maintenance manual.
	General warning sign. Risk of danger or possibility of damage to the machine. Read carefully the text related to this sign.
	Electrical hazard. The relevant text outlines conditions which could result fatal. The related instructions must be strictly respected.
	Danger hazard. Part or system under pressure.
	Danger hazard. Component or system which during the operation can reach high temperature.
	Danger hazard. It's absolutely forbidden to breathe the air treated with this apparatus.
	Danger hazard: It's absolutely forbidden to use water to extinguish fire on the dryer or in the surrounding area.
	Danger hazard; It's absolutely forbidden to operate the machine when the parts (under pressure or electric panels) are not in place or have been tampered with and changed.
	Danger hazard: machine level noise could be higher than 85 dBA. It is mandatory to install the machine in dedicated area where people are not normally present. The installer and/or the user is responsible for correct installation of the dryer, in order to prevent noise propagation to the near work environment. The installer and/or the user is also responsible for the safety signs affixing into installation site.
	Attention: the User or Operator must wear hearing protection before performing any procedure on the dryer. All personnel must select the proper PPD (Personal Protection Device) hearing protector (earmuffs, ear canal caps or ear plugs) in order to prevent damage to the person's hearing.

	<p>Maintenance and/or control operation to be very carefully performed by qualified personnel 1.</p>
	<p>Compressed air inlet connection point.</p>
	<p>Compressed air outlet connection point.</p>
	<p>Condensate drain connection point.</p>
	<p>Operations which can be worked out by the operator of the machine, if qualified 1.</p>
	<div style="text-align: center; background-color: black; color: white; padding: 5px;">NOTE</div> <div style="border: 1px solid black; padding: 5px; margin: 5px auto; width: fit-content;"> <p>Text to be taken into account, but not involving safety precautions.</p> </div>
	<p>In designing this unit a lot of care has been devoted to the protection of the environment:</p> <ul style="list-style-type: none"> • Dryer and relevant packaging composed of recyclable materials. • Energy saving design. <p>Not to spoil our commitment, the user should follow the few ecological suggestions marked with this sign.</p>

2.3 WARNINGS

	<p>Compressed air is a highly hazardous energy source. Never work on the dryer with parts under pressure. Never point the compressed air or the condensate drain jet towards anybody.</p> <p>The user is responsible for the installation of the dryer, which has to be executed on the basis of the instructions given in the “Installation” chapter. Otherwise, the warranty will be voided and dangerous situations for the personnel and/or damages to the machine could occur.</p>
	<p>Only qualified personnel can use and service electrically powered devices. Before attempting any maintenance action, the following conditions must be satisfied :</p> <ul style="list-style-type: none"> • Ensure that any part of the machine is under voltage and that it cannot be connected to the mains. • Ensure that any part of the dryer is under pressure and that it cannot be connected to the compressed air system.
	<p>Any change to the machine or to the relevant operating parameters, if not previously verified and authorised by the Manufacturer, in addition to create the possibility of dangerous conditions it will void the warranty.</p>
	<p>Don't use water to extinguish fire on the dryer or in the surrounding area.</p>

2.4 PROPER USE OF THE DRYER

This dryer has been designed, manufactured and tested only to be used to separate the humidity normally contained in compressed air. Any other use has to be considered improper. The Manufacturer will not be responsible for any problem arising from improper use; the user will be in any case responsible for any resulting damage.

Moreover, the correct use requires the compliance with the installation conditions, in particular:

- Voltage and frequency of the primary electrical supply.
- Pressure, temperature and flow-rate of the incoming air.
- Ambient temperature.

This dryer is supplied tested and fully assembled. The only operation left to the user is the installation of the desiccant into the dryer towers and the connection to the plant in compliance with the instructions given in the following chapters.



The purpose of the machine is the separation of water present in compressed air. The dried air cannot be used for respiration purposes or for operations leading to direct contact with foodstuff, unless subject to further treatments.

2.5 INSTRUCTIONS FOR THE USE OF PRESSURE EQUIPMENT

To ensure the safe operation of pressure equipments, the user must conform strictly to the following:

1. The equipment must only be operated within the temperature and pressure limits stated on the manufacturers name/data plate.
2. No welding is allowed on the shell and end caps.
3. The equipment must not be stored in badly ventilated spaces, near a heat source or inflammable substances.
4. Vibration must be eliminated from the equipment to prevent fatigue failure.
5. An internal inspection must be carried out at 12 month intervals to check for pressure equipment corrosion. The actual wall thickness of the tower after corrosion should not be less than the data indicated on the chart located on the side on the tower.
6. Condensate drains should be checked for operation every day to prevent a build up of condensate in the pressure equipment.
7. The maximum working pressure stated on the manufacturers data plate must not be exceeded.
8. All documentation supplied with the equipment (manual, declaration of conformity etc.) must be kept for future reference.

NOTES

Section 3

INSTALLATION

3.1 TRANSPORT

Once verified the integrity of the packaging, place the unit near to the installation point and unpack the contents.

- To move the packaged unit we suggest to use a suitable crane or forklift. We do not recommend using hands.
- Handle with care. Improper handling could cause irreparable damage.
- Even when packaged, keep the machine protected from severity of the weather.

	<p>The packaging materials are recyclable. Each single material must be properly disposed in a manner complying with the rules in force in the destination country.</p>
--	---

3.2 INSTALLATION SITE



Particular care is required in selecting the installation site, as an improper location could jeopardise the proper operation of the dryer.

This unit is not suitable to be used in explosive atmosphere, where risk of fire could exist, or in presence of gaseous or solid polluting material.



Don't use water to extinguish fire on the dryer or in the surrounding area.



Machine level noise could be higher than 85 dBA. It is mandatory to install the machine in dedicated area where people are not normally present. The installer and/or the user is responsible for correct installation of the dryer, in order to prevent noise propagation to the near work environment. The installer and/or the user is also responsible for the safety signs affixing into installation site.



Maintenance personnel must wear hearing protection while operating the dryer. Each employee must select proper PPD (Personal Protection Device) hearing protector (earmuffs, ear canal caps and earplugs) in order to prevent discomfort or damage to the operator's hearing.

Minimal installation requirements:

- Select a clean room dry, free from dust, and protected from atmospheric disturbances.
- The supporting area must be smooth, level and able to hold the weight of the dryer.
- Minimum ambient temperature 34°F, 1°C.
- Maximum ambient temperature 120°F, 5°C.
- Allow at least a clearance of 3 feet (1 meter) on each side of the dryer to facilitate possible maintenance operations.
- The dryer is required to be fixed to the supporting surface.

3.3 INSTALLATION LAYOUT



Dryer is supplied with 0.01 micron filter on the inlet and a 1 micron filter on the outlet.

Type A installation is suggested when the compressed air treated from the dryer is only a part of the total flow rate of the compressor; or when the compressor operates at reduced intermittence and the total consumption equals the compressor flow rate.

Table 3-1: Correction Factor for inlet Pressure

PSIG	50	60	70	80	90	100	110	120	130	140	150	175	200	225	250
BAR	3.5	4.1	4.8	5.5	6.2	6.9	7.6	8.3	9.0	9.7	10.3	12.1	13.8	15.5	17.3
F1 Factor	0.56	0.65	0.74	0.83	0.91	1.0	1.06	1.08	1.12	1.16	1.2	1.29	1.37	1.45	1.52

Table 3-2: Correction factor for Inlet Temperature

°F	70	80	90	100	105	110	115	120
°C	21	27	32	38	40	43	46	49
F2 Factor	1.12	1.09	1.06	1.0	0.93	0.86	0.80	0.75

CLEAN DRY, CONTAMINANT FREE AIR

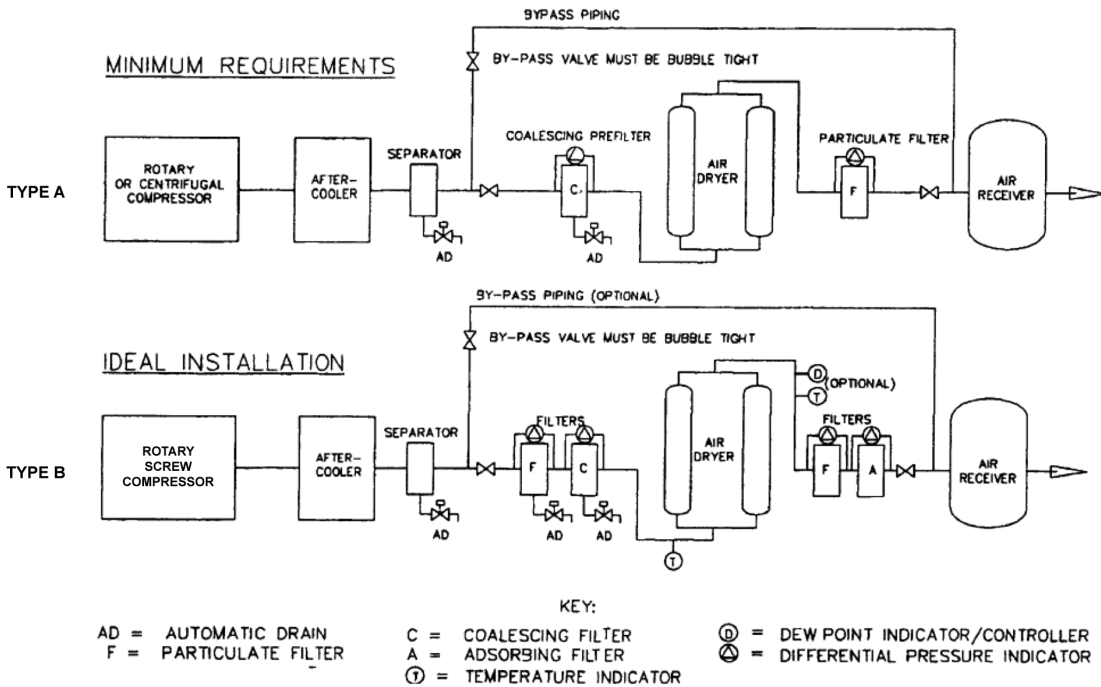

Figure 3-1: Recommended Installation

SECTION 3

DHL HEATLESS REGENERATIVE DRYER

3.4 OPERATING CONDITIONS

- Maximum working pressure 150 PSIG (10 Bar) for higher pressure contact factory.
- Minimum working pressure 60 PSIG (4 bar)
- Maximum inlet temperature 120°F (49°C)
- Minimum ambient temperature: 34°F (1.6°C) for lower ambient temperature contact factory.

EXAMPLE:

A (DHL-250) has a nominal capacity of 250 SCFM.

What is the maximum allowable flow through the dryer at following operating conditions?:

Air Inlet Pressure: 110 Psig (7.6 Bar) From table for pressure correction F1=1.04

Air Inlet temperature: 105°F (40°C) From table for temperature correction F2=0.93

Air Flow Capacity	=	Nominal Capacity of Dryer	X	Factor F1	X	Factor F2
-------------------	---	---------------------------	---	-----------	---	-----------

241.8 (Air Flow Capacity)	=	250 SCFM	X	1.04 (F1)	X	0.93 (F2)
Air Flow Capacity= 241.8 SCFM. This is the maximum air flow rate that the dryer can accept under those operating conditions.						

3.5 CONNECTION TO THE COMPRESSED AIR SYSTEM



Operations to be performed by qualified personnel. Connections to be performed by qualified personal. Never do service with dryer under pressure.

The user is responsible to ensure that the dryer will never be operated with pressure exceeding the nominal values. Eventual over-pressure could be dangerous both for the operator and the machine.

The temperature and the amount of air entering the dryer must comply with the limits reported on the data plate. In the event of particularly high inlet temperatures, the installation of additional cooling equipment such as water cooled after cooler or refrigerated after cooler may be necessary. The air supply piping should be free from dust, rust, ships and other debris and must be sized to consistent with the flow- rate of the dryer.

In designing the dryer, particular measures have been taken in order to limit the vibration which could occur during the operation. Therefore we recommend to use connecting pipes able to insulate the dryer from possible vibrations originating from the line (flexible hoses, vibration damping fittings, etc.).

3.6 CONNECTION TO THE ELECTRICAL SUPPLY



The connection to the electrical supply, to be carried out by qualified personnel, and the safety systems must comply with local rules and laws.

Before connecting the unit to the electric power, verify that the voltage and the frequency available on the electrical supply correspond to the data reported on the data plate of the dryer. In terms of voltage, a $\pm 5\%$ tolerance is allowed. The dryer comes with a mains connecting cable already installed (6 ft).

The electrical power supply must have a breaker equipped with ground fault protection.

The sizing of the electrical supply wiring should be properly sized for the electrical specification for the dryer model being installed. The ambient temperature, voltage, length of wiring and all applicable local electrical codes should all be considered whe sizing the electrical wiring.



It is mandatory to ensure the connection to the ground terminal.

3.7 INLET FILTER CONDENSATE DRAIN



The condensate is discharged at the same pressure of the air entering the dryer.

Never point the condensate drain jet towards anybody.

The dryer is already supplied with ¼" flexible hose to be connected to the Collecting device (Oil/water separator).

Connect and properly fasten the condensate drain to a collecting plant or container.

The drain cannot be connected to pressurised systems.



Don't dispose the condensate in the environment.

The condensate collected in the dryer contains oil particles released in the air

by the compressor.

Dispose the condensate in compliance with the local rules.

Sullair recommends the installation of an oil/water separator to treat the condensate being drained from the compressors, dryers, filters, receivers, etc.

Section 4

STARTUP

4.1 PRELIMINARY OPERATION



Verify that the operating parameters match with the nominal values reported on the data plate of the dryer (voltage, frequency, air pressure, air temperature, ambient temperature, etc.).

Before delivery, each dryer is submitted to accurate tests simulating real operating conditions. Nevertheless, the unit could be damaged during transportation. We therefore suggest to check the integrity of the dryer upon arrival and to keep it under observation during the first hours of operation.



The start-up must be performed by qualified personnel.

It's mandatory that the engineer in charge will adopt safe operational conditions complying with the local safety and accident prevention requirements.



The same engineer will be responsible for the proper and safe operation of the dryer.

Never operate the dryer if its panels are not in place.

4.2 FIRST START-UP



At the first start-up, or in case of start-up after a long inactivity period or following to maintenance operations, comply with the instructions given below. The start-up must be performed by qualified personnel.



Maintenance personnel must wear hearing protection while operating the dryer. Each employee must select proper PPD (Personal Protection Device) hearing protector (earmuffs, ear canal

caps and earplugs) in order to prevent any discomfort or damage to the operator's hearing.

SEQUENCE OF OPERATIONS:

- Verify that the factory settings, indicated in the plate "REMOVE BEFORE THE 1ST START UP" (on the control panel), match the real operating conditions requested.
- Verify that all the steps of the "Installation" chapter have been observed.
- Verify that the connection to the compressed air system is correct and that the piping is suitably fixed.
- Verify that the condensate drain pipe is properly fastened and connected to a collection system or container.
- Remove any packaging and other material which could obstruct the area around the dryer.
- Pressurize the dryer slowly.
- Close the breaker for the electrical supply.
- Verify that the control panel is on.
- Check the piping for air leakage.
- Test the drain of the inlet filter.
- After 2 minutes from the start-up the adsorption tower B is depressurized.
- Wait for the dryer to make a few cycles (there is an alternation of depressurization from tower A to tower B)
- The cycle is inverted every 2 minutes (DewPoint of $-94^{\circ}\text{F}/-70^{\circ}\text{C}$) or every 4 minutes (DewPoint of $-40^{\circ}\text{F}/-40^{\circ}\text{C}$) or every 7 minutes (DewPoint of $-4^{\circ}\text{F}/-20^{\circ}\text{C}$); it depends on the dryer set-up.

NOTE

During the first days of operation, the DewPoint is not ensured because the adsorption material can contain humidity.

At the first start-up, or in case of start-up after a long inactivity period or following the maintenance operations, we recommend using the dryer at a reduced nominal flow of 50% during the first two days.

4.3 OPERATION AND SWITCHING OFF



Maintenance personnel must wear hearing protection while operating the dryer. Each employee must select proper PPD (Personal Protection Device) hearing protector (earmuffs, ear canal caps and earplugs) in order to prevent any uneasiness that could cause dangerous situation for him.

Operation:

- Pressurize the dryer slowly.
- Activate the on/off switch.
- Verify that the control panel is on.
- Wait for the first cycles of the inlet filter drain or make the drain test manually.
- During the first two minutes both the towers are pressurized
- Wait for the dryer to make some cycles (there is an alternation of depressurization from tower A to tower B).

Switching off:

- Check if the inlet filter condensate drain works regularly.
- Stop the air flow.
- Depressurize the dryer.
- Deactivate the on/off switch.

NOTE

During the working of the dryer, both the towers are cyclically depressurized in order to be regenerated. The depressurized tower is crossed from part of the compressed air already dried, which will be expelled outside. The noise of the compressed air during the draining is muffled by silencers.

Section 5
TECHNICAL SPECIFICATIONS

Model#	Inlet Flow Capacity @100 PSIG (CFM)	Voltage 115/1/60 220/1/50	Inlet/Outlet Connections (inches)	Dimensions L x W x H (inches)	Weight (Lbs)
DHL-80	80	115/208	¾" NPT	32x24x83	550
DHL-100	100	115/208	1" NPT	32x24x83	690
DHL-150	150	115/208	1" NPT	32x24x87	810
DHL-200	200	115/208	1" NPT	32x24x87	850
DHL-250	250	115/208	1 ½" NPT	40x24x87	1010
DHL-300	300	115/208	1 ½" NPT	40x24x87	1200
DHL-400	375	115/208	1 ½" NPT	46x26x88	1350
DHL-500	500	115/208	2" NPT	46x26x88	1460
DHL-600	650	115/208	2" NPT	46x26x88	1790
DHL-800	800	115/208	3" FLG	55x48x105	2150
DHL-1000	1000	115/208	3" FLG	55x48x105	2960
DHL-1250	1250	115/208	3" FLG	60x50x109	3470
DHL-1500	1500	115/208	3" FLG	60x50x109	4180
DHL-2000	2000	115/208	3" FLG	70x62x115	4980
DHL-2500	2500	115/208	4" FLG	70x62x115	5800
DHL-3000	3000	115/208	4" FLG	80x70x120	6400
DHL-4000	4000	115/208	6" FLG	90x80x122	9100
DHL-5000	5000	115/208	6" FLG	98x86x120	11800

NOTES

Section 6

TECHNICAL DESCRIPTION

6.1 CONTROL PANEL

The only interface between the dryer and the operator is the control panel shown below.

6.2 DESCRIPTION OF OPERATION

The regenerated adsorption dryers of the DHL series are fitted with two tanks filled with activated alumina. While the compressed air is dried in one tower, the saturated desiccant is regenerated in the second. A small portion of the already treated air is used for the regeneration process and eliminated along with the condensate, through the silencers.

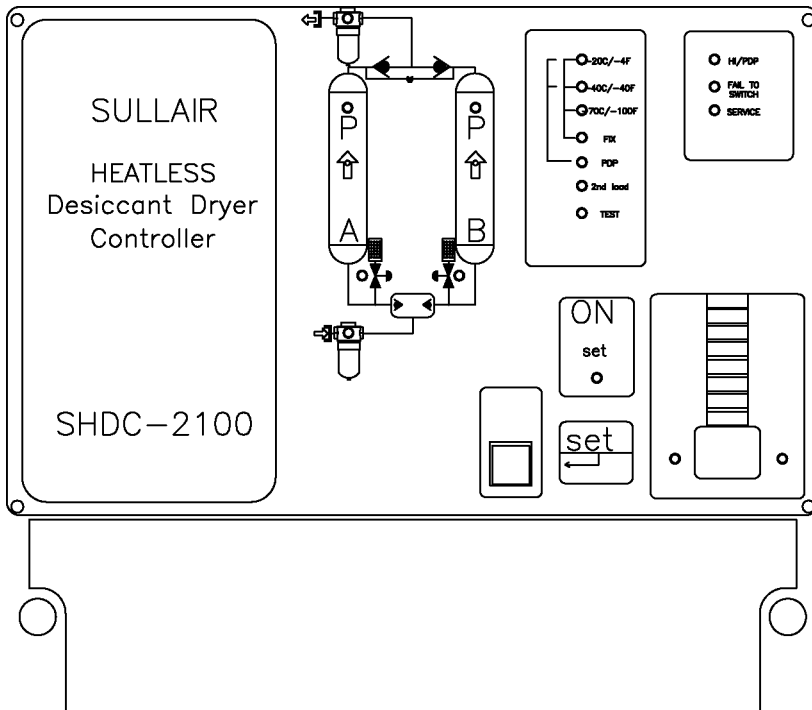

- Main switch
- SHDC-2100 electronic device
- Terminal board

Figure 6-1: Control Panel

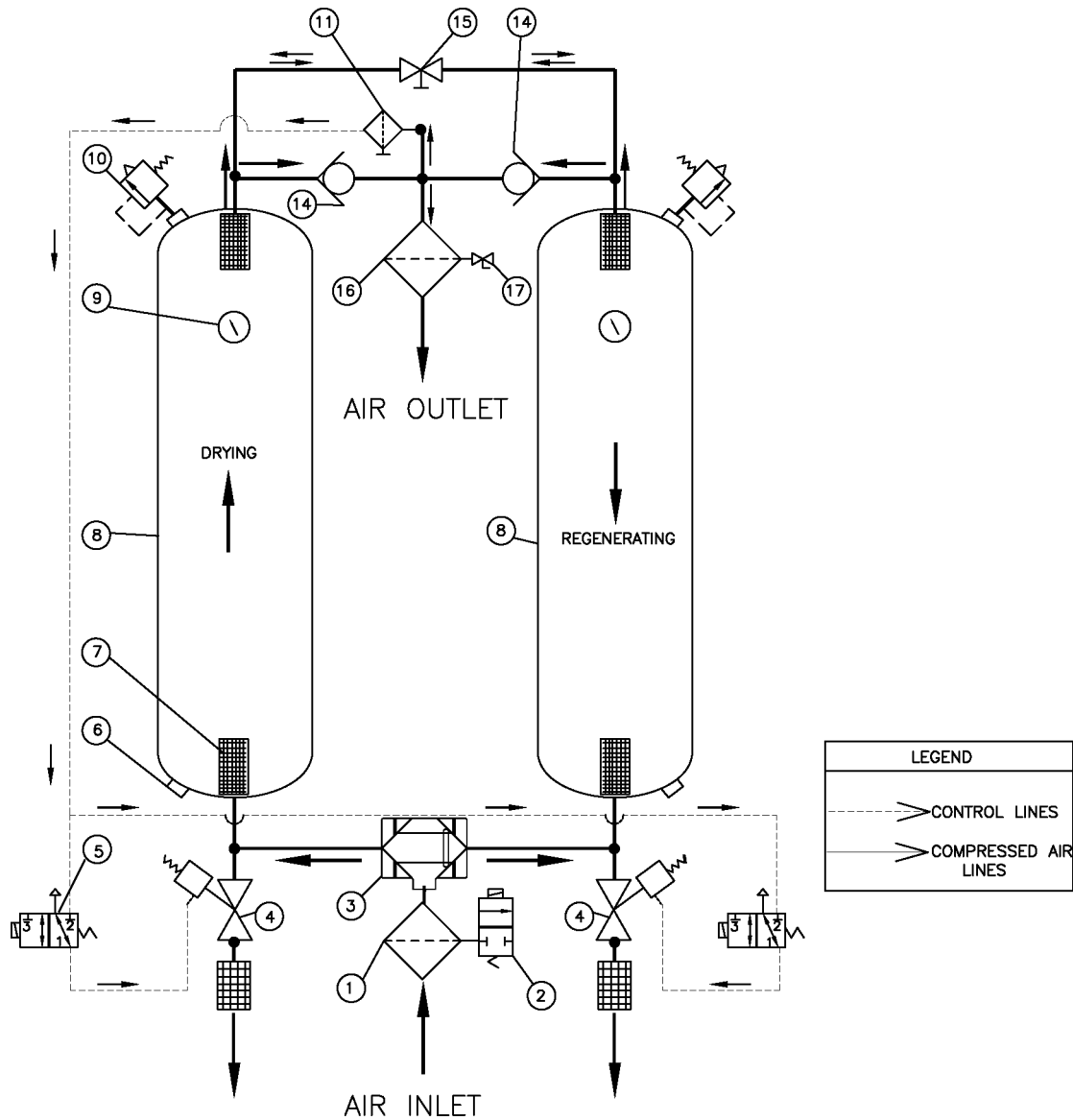

ITEM	QTY	DESCRIPTION	ITEM	QTY	DESCRIPTION
1	1	coalescing pre-filter	10	2	pressure relief valve (set @ 200 psig)
2	1	pre-filter electronic drain valve	11	1	control air filter
3	1	bi-directional purge adjustment valve	12	1	control air tubing (1/4")
4	2	angle body purge exhaust valve	13	2	gauge snubber
5	2	purge pilot valve	14	2	outlet check valve
6	4	desiccant drain port	15	1	purge adjustment valve
7	4	stainless steel inlet defuzer	16	1	after filter particulate type
8	2	pressure vessels	17	1	manual drain ball valve
9	2	pressure gauge			

Figure 6-2: Flow Diagram

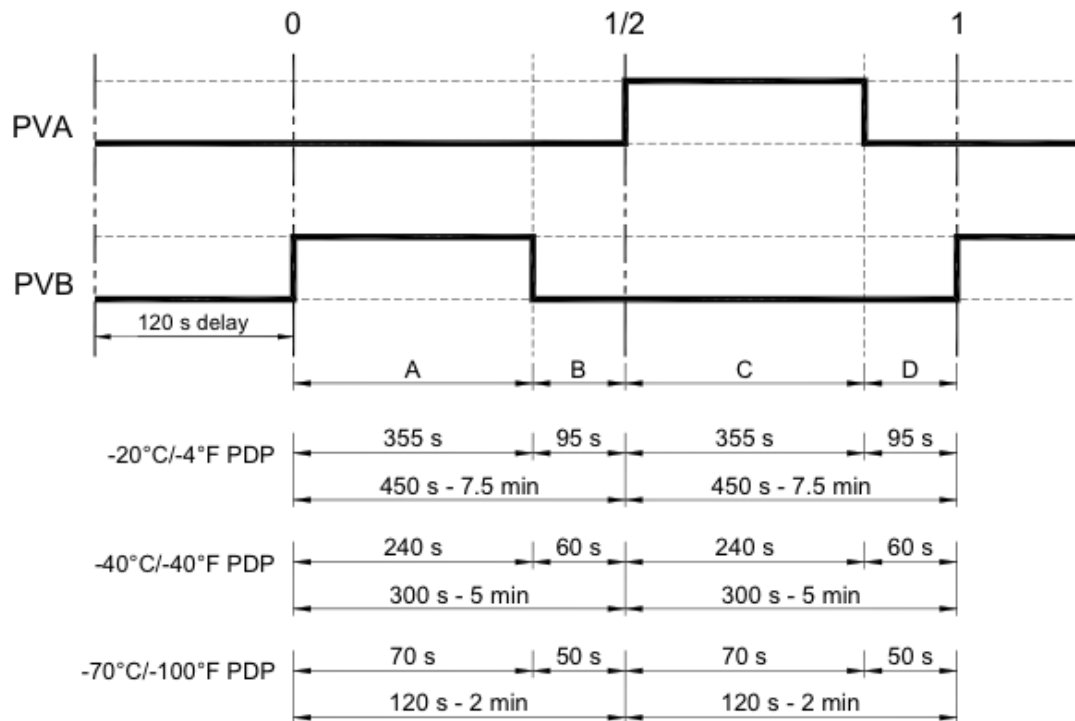

Figure 6-3: Timing Sequence Diagram

6.3 OPERATION

The dryer described in this manual takes advantage of the adsorption properties of the desiccant material which the two towers (tanks) are filled with.

These towers, with the same dimensions, are alternately crossed from the compressed air.

The cycle time is set during the manufacturing phase (as well as the regeneration nozzle) according to the requested DewPoint PDP (reference model max. 10 barg) :

- 15 minutes for -4 0F-20°C
- 10 minutes for -40 0F-40°C
- 4 minutes for -94 0F-70°C

6.4 PURGE METERING VALVE SETTINGS

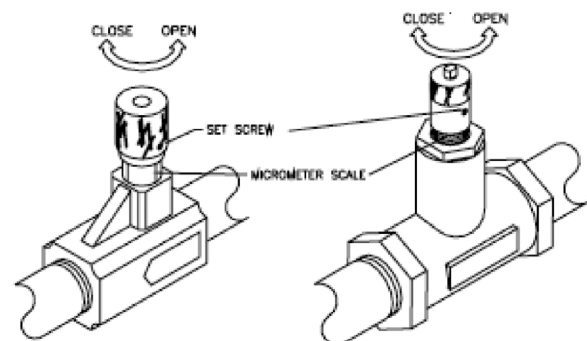

<i>Table 6-1: Purge Metering Valve Settings</i>						
MODEL	INLET PRESSURE					
	70 PSIG	80 PSIG	90 PSIG	100 PSIG	125 PSIG	150 PSIG
DHL-80	3.5 turns	3.4 turns	3.3 turns	3.2 turns	3.0 turns	2.8 turns
DHL-100	3.7 turns	3.6 turns	3.5 turns	3.5 turns	3.3 turns	3.1 turns
DHL-150	4.5 turns	4.3 turns	4.2 turns	4.0 turns	3.8 turns	3.6 turns
DHL-200	3.5 turns	3.4 turns	3.3 turns	3.2 turns	3.0 turns	2.8 turns
DHL-250	3.7 turns	3.6 turns	3.5 turns	3.5 turns	3.3 turns	3.1 turns
DHL-300	4.5 turns	4.3 turns	4.2 turns	4.0 turns	3.8 turns	3.6 turns
DHL-350	3.5 turns	3.4 turns	3.3 turns	3.2 turns	3.0 turns	2.8 turns
DHL-400	3.7 turns	3.6 turns	3.5 turns	3.5 turns	3.3 turns	3.1 turns
DHL-450	4.5 turns	4.3 turns	4.1 turns	3.9 turns	3.8 turns	3.6 turns
DHL-500	5.5 turns	5.2 turns	5.0 turns	4.8 turns	4.5 turns	4.2 turns
DHL-600	2.6 turns	2.5 turns	2.4 turns	2.3 turns	2.2 turns	2.0 turns
DHL-750	2.7 turns	2.6 turns	2.5 turns	2.4 turns	2.3 turns	2.2 turns
DHL-800	2.8 turns	2.7 turns	2.6 turns	2.5 turns	2.4 turns	2.3 turns
DHL-900	3.0 turns	2.9 turns	2.8 turns	2.7 turns	2.6 turns	2.5 turns
DHL-1000	3.2 turns	3.1 turns	3.0 turns	2.9 turns	2.8 turns	2.7 turns
DHL-1250	3.5 turns	3.4 turns	3.3 turns	3.2 turns	3.1 turns	3.0 turns
DHL-1500	3.1 turns	3.0 turns	2.9 turns	2.8 turns	2.7 turns	2.5 turns
DHL-2000	3.6 turns	3.5 turns	3.4 turns	3.3 turns	3.1 turns	2.8 turns
DHL-2500	4.0 turns	3.9 turns	3.8 turns	3.7 turns	3.4 turns	3.1 turns
DHL-3000	4.3 turns	4.2 turns	4.1 turns	4.0 turns	3.6 turns	3.3 turns
DHL-4000	Contact Factory	Contact Factory	Contact Factory	Contact Factory	Contact Factory	Contact Factory
DHL-5000	Contact Factory	Contact Factory	Contact Factory	Contact Factory	Contact Factory	Contact Factory

3/8" Valve is used on models DHL80-150
 1/2" Valve is used on models DHL200-300
 3/4" Valve is used on models DHL 350-500
 1" Valve is used on models DHL600-1250
 1.5" Valve is used on models DHL1500-3000

6.5 CYCLE DESCRIPTION

During the start-up both regeneration drain solenoid valves PVA and PVB are closed (for about 120 seconds) to guarantee the complete pressurization of the dryer.	
Stage A	<p>The solenoid valve PVB is supplied so the tower B is depressurized. Both inlet and outlet spools of shuttle valves move towards tower B (side without pressure). The compressed air flow is directed to tower A, where the desiccant material adsorbs the humidity up to the target Dew Point.</p> <p>Through the regeneration nozzle a calibrated part of dry air coming out from tower A is expanded towards tower B. This air (particularly dry for this expansion operation) while crossing tower B, dries the adsorbent material dragging away the humidity through the PVB solenoid valve and the silencers. At the end of this stage the adsorption material of tower B is completely regenerated.</p>
Stage B	The solenoid valve PVB is closed and then through the regeneration nozzle tower B is pressurized again up to the working pressure. The sum of stages A + B equals a half cycle time.
Stage C	<p>The solenoid valve PVA is supplied so tower A is depressurized. Both inlet and outlet spools of shuttle valves move towards tower A (side without pressure). The compressed air flow is directed to tower B, where the desiccant material adsorbs the humidity up to the target DewPoint.</p> <p>Through the regeneration nozzle a calibrated part of dry air coming out from tower B is expanded towards tower A. This air (particularly dry for this expansion operation) while crossing tower A, dries the adsorbent material dragging away the humidity through the PVB solenoid valve and the silencers. At the end of this stage the adsorption material of tower A is completely regenerated.</p>
Stage D	The solenoid valve a PVA is closed and then through the regeneration nozzle tower A is pressurized again up to the working pressure. The sum of stages C + D equals a half cycle time. At the end the cycle starts up' again from phase A.

NOTE

The cycles are symmetrical therefore A=C and B=D

The desiccant material, if contaminated from lubricant oil, loses its adsorption propriety. Moreover during operation, the desiccant can release solid

particles (powders) particularly abrasive and extremely damaging for the final users.

For this reason the dryer is equipped with two high-efficiency filters:

- Inlet filter, 0.01 micron filtration grade, with differential gauge and electronic timed drain or zero loss drain optional.
- Outlet filter, 1 micron filtration grade, with differential gauge and manual drain.

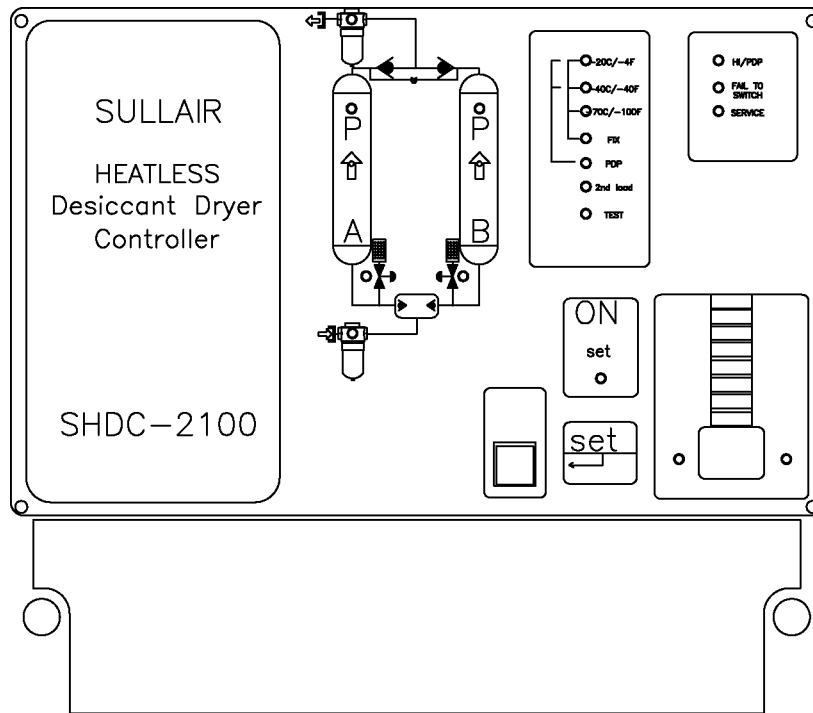

	KEY	On During Programming		LED	On = tower under pressure
	KEY	Test condensate drain / increase value / reset alarm		LED	On = inlet filter clogged
	LED	On = device powered		LED	On = outlet filter clogged
		Flashing = under programming		LED	Alarm: DewPoint too high
	LED	On = display shows % of set load		LED	Alarm: operating cycle did not switch
	LED	On = display shows DewPoint temperature		LED	Alarm: maintenance intervention
	LED	On = tower under adsorption		KEY	Reset cartridge replacement
	LED	On = air breathing solenoid valve regeneration open		KEY	Reset desiccant replacement

Figure 6-4: Electronic Instrument SHDC-2100

SECTION 6

DHL HEATLESS REGENERATIVE DRYER

The correct operation of the dryer is controlled and monitored constantly by the SHDC-2100 device. The device carries out many functions:

1. It displays the operating status through the Control panel LED panel;
2. It can be used to select the operating Dew-Point;
3. It can be used to select the operating mode (FIX, DPD and TEST);
4. It can be used to enable the “Energy Save” function.

6.6 CONTROL PANEL

The Control panel LED panel is divided into four different display area. Each one represents the specific functions of the dryer, more precisely:

1. The LEDs on the left, positioned on the flow diagram, represent the various operating phases of the dryer.
2. The LEDs of the “Cycle mode” menu display the operating mode of the dryer, selected by the operator during the programming phase (see Section 6.7).
3. The LEDs of the “Alarm” menu represent any anomaly and/or malfunctioning of the machine.
4. The LEDs and the DISPLAY on the right display the various load percentages the dryer operates with.

The On/Off switch is located on the side of the control box. Press the On/Off switch to power up the control panel and energize the following LED.



The LEDs on the flow diagram of the Control panel show the operating status of the dryer, precisely:

1. At **start up** both the purge solenoid valves are closed (for about 120 seconds) therefore the relevant LEDs are off. The compressed air passes through both drying towers, to pressurize the dryer and therefore the LEDs are on.

2. After 120 sec. The dryer starts the first operating cycle: “**Phase A**”, tower B is de-pressurized, LED B switches off and the PVB solenoid valve is opened (LED B on) to vent the air used for the regeneration.

3. Afterwards, the dryer starts the “**Phase B**” re-pressurization of tower B, therefore solenoid valve PVB shuts down (LED B off). LED B switches on when the pressure switch reaches the calibration value (if the pressure-switch Kit is installed– optional).

4. When the towers are once again pressure balanced the second part of the cycle time starts with “**Phase C**”, where tower A is de-pressurized, LED A switches off and the solenoid valve PVA is opened (LED A on) to vent the air used for regeneration.

5. The machine cycle ends with the re-pressurization “**Phase D**” of tower A, the solenoid valve PVA closes (LED A off). LED B switches on when the pressure switch reaches the calibration value (if the pressure-switch Kit is installed– optional).

According to the selected operating mode (see Section 6.9) the following LEDs of the “Cycle mode” menu can be on:					
Mode: FIX	The dryer runs with fixed cycle times.				
	DewPoint under pressure PDP : -20°C		DewPoint under pressure PDP : -40°C		DewPoint under pressure PDP : -70°C

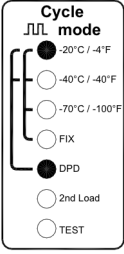
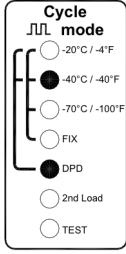
<p>Mode: DPD</p>	<p>The dryer operates with cycle times proportional to the applied load (if the DewPoint probe is installed – optional).</p>		
	<p>DewPoint under pressure PDP : -20°C</p>		<p>DewPoint under pressure PDP : -40°C</p>

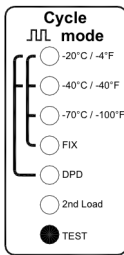
<p>Mode: TEST</p>	<p>Diagnostic cycle, with step-by-step operation to make troubleshooting operations easier.</p>		
			

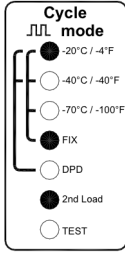
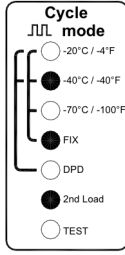
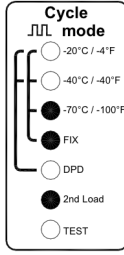
<p>Mode: FIX Function: 2nd Load</p>	<p>The dryer operates with fixed cycle times and allows the operator to choose, only in FIX modality through an external contact, a second setting for the foreseen applied load (installation directly downstream of one or more than one compressor).</p>				
	<p>DewPoint under pressure PDP : -20°C</p>		<p>DewPoint under pressure PDP : -40°C</p>		<p>DewPoint under pressure PDP : -70°C</p>

The Control panel shows any anomaly and/or malfunctioning through the LEDs of the “Alarm” menu. The LEDs flash when the alarm is active and they stay on when the alarm has stopped, but has not yet been reset. More precisely:

	<p>When the LED is flashing it means the alarm went off for a high DewPoint. The function can be activated only if the DewPoint probe is installed – optional – and only after having correctly set the relating DIP-SWITCH (see <i>Section 6.9</i>).</p>
	<p>The LED flashes when the towers did not switch properly. This alarm is particularly important because it helps avoid possible de-pressurizations of the distribution circuit through the dryer. The function can be enabled only if the pressure switch kit is installed – optional – and only after having correctly set the relating DIP-SWITCH (see <i>Section 6.9</i>).</p>
	<p>If the “SERVICE” LED and the LED of the flow diagram are flashing at the same time, it means that the dryer inlet filter is clogged and therefore it must be replaced. This alarm does not affect the operation of the dryer, but maintenance interventions are needed. Please refer to the User and Maintenance manual of the filter itself.</p>
	<p>If the “SERVICE” LED and the LED of the flow diagram are flashing at the same time, it means that the dryer outlet filter is clogged and therefore it must be replaced. This alarm does not affect the operation of the dryer, but maintenance interventions are needed. Please refer to the User and Maintenance manual of the filter itself.</p>
	<p>If the “SERVICE” LED and both LEDs of the flow diagram are flashing at the same time, the timer for the programmed maintenance of the filters has gone off.</p>
	<p>If the “SERVICE” LED and both LEDs of the flow diagram are flashing at the same time, the timer for the programmed maintenance of the desiccant material has gone off.</p>

When the LED is on, the 10 LED DISPLAY shows the load percentage of the “1st Load”, set by the operator during the programming phase. By pressing the key , the DISPLAY shows the load percentage of the “2nd Load” and the LED of the “Cycle mode” menu lights up at the same time.



Press the key again and the 10 LED DISPLAY shows the DewPoint temperature read by the DewPoint meter (if installed); at the same time the LED lights up.

The chart below shows the values matching each LED of the DISPLAY :

LED N.	1	2	3	4	5	6	7	8	9	10
Display of Load %	OFF	30	-	40	50	60	70	80	90	100
Display of Dewpoint	0	-5	-10	-15	-20	-25	-30	-35	-40	-45
Note:	In DewPoint display, the intermediate temperatures are indicated by the two LEDs adjacent the value (for example at -2.5°C both LEDs 1 and 2 light up, or at -22.5°C LEDs 5 and 6 light up).									
Note:	In DewPoint display LED 1 flashes for temperatures higher than +10°C, whereas LED 10 flashes for temperatures lower than -60°C. In case of anomalies on the probe all the LEDs switch off.									

6.7 OPERATION CONFIGURATION

The electronic board, indicated below and positioned inside the SHDC-2100 device, allows for the adjustment and control of the main operating parameters.

	<p>Only qualified personnel must configure the dryer. Before any changes are made, verify that:</p> <ul style="list-style-type: none"> • no part of the machine is powered and that it cannot be connected to the electrical supply. <p>Access the part by removing the terminal board cover (No. 3 of the control panel—see <i>Section 6.1: CONTROL PANEL</i>) and/or the Control panel of the SHDC-2100 device.</p>
	<p>Any modifications to the operating configuration not compatible with the ones recommended by the manufacturer can cause malfunctioning, possible damages to parts of the machine and a premature deterioration of the adsorbent material and of the inlet and outlet dryer filters.</p>

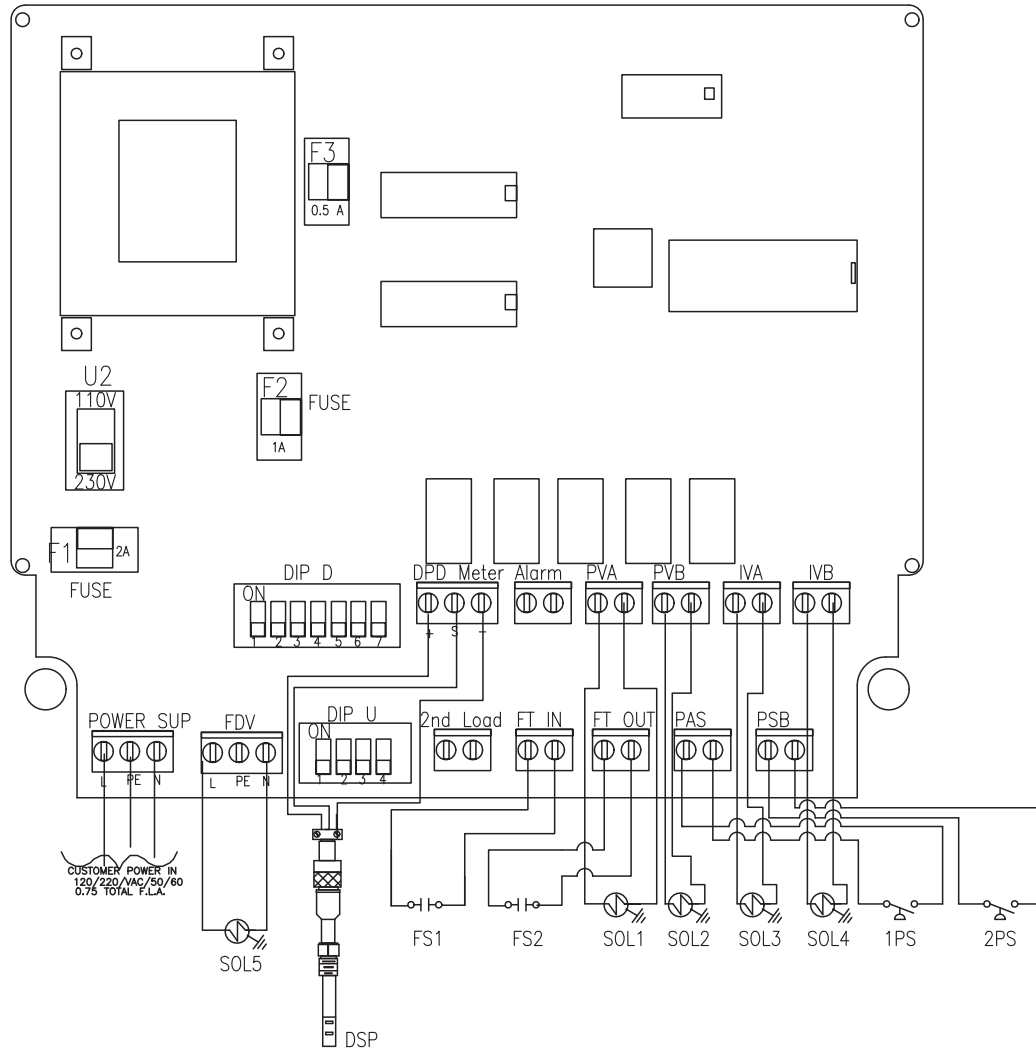



SYM	DESCRIPTION
SOL1	LEFT TOWER PURGE EXHAUST PILOT SOLENOID VALVE
SOL2	RIGHT TOWER PURGE EXHAUST PILOT SOLENOID VALVE
SOL3	LEFT TOWER INLT PILOT SOLENOID VALVE
SOL4	RIGHT TOWER INLET PILOT SOLENOID VALVE
SOL5	DRAIN SOLENOID VALVE (115-1-60 OR 220-1-50)
FS1	OPTIONAL: FILTER ELEMENT CHANGE SWITCH INLET FILTER
FS2	OPTIONAL: FILTER ELEMENT CHANGE SWITCH OUTLET FILTER
1PS	OPTIONAL: SWITCHING VALVE FAILURE RIGHT TOWER SWITCH
2PS	OPTIONAL: SWITCHING VALVE FAILURE LEFT TOWER SWITCH
DPS	OPTIONAL: DEW POINT MOISTURE SENSOR PROBE

Figure 6-5: SHDC-2100 Component Layout

6.8 POWER SELECTOR

The SHDC-2100 device is able to operate with different voltage ranges (1/100-120V/50-60Hz or 1/ 220-240V/50-60Hz). Before starting up the machine

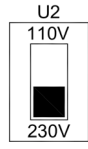
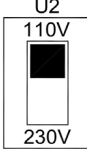
it is necessary to open the device and verify that the U2 switch of the electronic board is set to the correct supply voltage:

	<p>With the switch in the lower position, the SHDC-2100 device must be powered at 220-240 V.</p>		<p>With the switch in the upper position, the SHDC-2100 device must be powered at 110-120 V.</p>
<p> The automatic drain on the filter at the dryer inlet, is supplied according to the power voltage indicated in the order; verify its compatibility with the former settings and especially with the plate data.</p>			

6.9 DIP-SWITCHES

The SHDC-2100 electronic board is fitted with two series of DIP-SWITCHES that are set during the

dryer test phase. If there are specific functional or control requirements, the Customer has the possibility of changing the operating parameters, by simply changing the set-up of the DIP-SWITCHES.

	<p>Only qualified personnel can perform the adjustment changes are made. Before any changes are made verify that:</p> <ul style="list-style-type: none"> • The machine has no parts under voltage and that it cannot be re-connected to the electrical supply. <p>The modification to the operating parameters through the variation of the position of the DIP-SWITCHES will be active only when the dryer starts up again.</p>
---	---

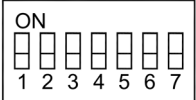
The second series of DIP-SWITCHES (DIP D) allows for the setting of the following parameters:			
<p style="text-align: center;">DIP D</p> 	DIP D1 and DIP D2	Selecting the operating cycle. The dryer can operate according to different operating cycles, according to the requested DewPoint or according to a diagnostic cycle (see Section 6.9).	1 OFF and 2 OFF = Cycle -40°C 1ONand2OFF=Cycle-70°C 1OFFand2ON=Cycle-20°C 1ONand2ON=CycleTest
	DIP D3	DPD Cycle. It can be used to start the operating mode with cycle times proportional to the applied load (if the second DewPoint probe is installed- optional). Priority must be given to the selection of DIPs D1 and DIP D2.	OFF = Not enabled (standard) ON = Enabled
	DIP D4	HI PDP alarm. It can be used to set off the alarm for a very high DewPoint (if the Dew-Point probe is installed- optional).	OFF = Not enabled (standard) ON = Enabled
	DIP D5	Use. It can be used to modify the internal maintenance timer, selecting a work cycle up to 3000 hours/year or higher (see Section 6.12).	OFF = up to 3000 hours/year (standard) ON = over 3000 hours/year
	DIP D6	Not Used.	—
	DIP D7	DewPoint probe.	OFF = probe disabled ON = probe enabled (standard)

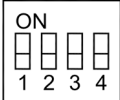
The first series of (DIP U) allows for the setting of the following parameters:			
<p style="text-align: center;">DIP U</p> 	DIP U1	Pressure. The SHDC-2100 device can operate with two different pressure ranges, according to the operating limits used to design the dryer (Standard Max. 10,3 barg; optional Max. 16 barg).	OFF = Low pressure - Max. 10,3 barg (standard) ON = High pressure - Max. 16 barg
	DIP U2	Fail to switch alarm. It can be used to enable the pressure switches to control the “Fail to Switch alarm” function.	OFF = Not installed (standard) ON = Installed
	DIP U3	FT Filter Management. Two differential manometers are connected to the inlet and outlet filters. They show the level of clogging of the cartridge and through an electric contact they transfer this signal to the SHDC-2100 device. The signal can be managed like a normally closed contact (pos. OFF) or an open contact (pos. ON).	OFF = contact closed → filter OK (standard) ON = contact open → filter OK (reverse)
	DIP U4	Not used.	—

6.10 OPERATING CYCLES

As described previously, the dryer can operate according to three different operating modes: FIX, DPD and TEST.

- Required Dew Point (- 4°F,-20°C, -40°F - 40°C, -94°F -70°C);
- Set load percentage (OFF ... 100%);
- Maximum dryer pressure (Max. 150 PSIG ,10,3 barg)

6.10.1 FIX

In FIX mode, the cycle times are managed according to the following operating parameters:

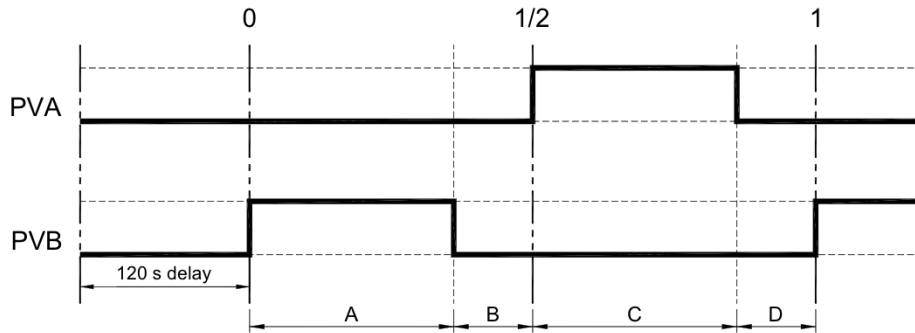

Figure 6-6: Timing Sequence Diagram

Load	Low Pressure						High Pressure					
	-20°C/-4°F		-40°C/-40°F		-70°C/-94°F		-20°C/-4°F		-40°C/-40°F		-70°C/-94°F	
	Time A	Time B	Time A	Time B	Time A	Time B	Time A	Time B	Time A	Time B	Time A	Time B
[%]	[s]	[s]	[s]	[s]	[s]	[s]	[s]	[s]	[s]	[s]	[s]	[s]
100	355	95	240	60	70	50	270	180	180	120	46	74
90	320	130	217	83	64	56	244	206	163	137	42	78
80	285	165	193	107	57	63	217	33	145	155	38	82
70	251	199	170	130	51	69	191	259	128	172	34	86
60	216	234	147	153	45	75	165	285	111	189	30	90
50	181	269	124	177	39	82	139	312	94	207	27	94
40	146	304	100	200	32	88	112	338	76	224	23	97
30	111	339	77	223	26	94	86	364	59	241	19	101
OFF	0	450	0	300	0	120	0	450	0	300	0	120

Note: Time A = Time C and Time B = Time D



If the default configuration is changed, verify that the installed nozzle is suitable for the new settings.

6.10.2 DPD

The DPD cycle (DewPoint Demand) is used to adapt the cycle times, that is the quantity of air needed for the regeneration, to the real load applied to the dryer. It is necessary to install a DewPoint meter (PDP Meter - optional) to achieve this. Set the DIP D3 on ON and the DIP D7 on ON. The DPD mode can be selected only for DewPoints of -20°C and -40°C (set

the requested condition on DIP D1 and DIP D2).

After the first four operating cycles following machine start-up, run in FIX mode, the SHDC-2100 device starts operating in DPD mode according to the following diagram:

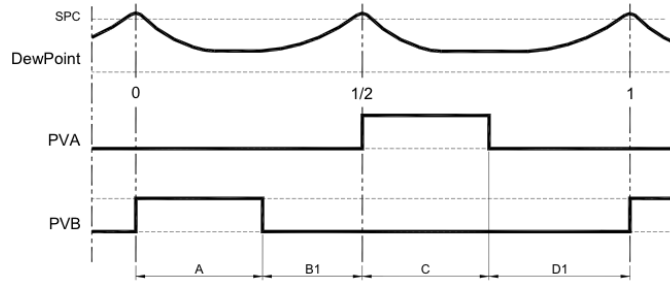

A = Regeneration time of tower A (fixed)

B = Re-pressurization time/stand-by tower A (variable)

C = Regeneration time of tower B (fixed)

D = Re-pressurization time/stand-by tower B (variable)

SPC = Switching Set-Point (-20°C or -40°C)

A = C

B1 can be different from D1

A+B1+C+D1=Complete cycle

Figure 6-7: DewPoint Demand Cycle Timing Sequence Diagram



While tower A is operating, tower B is regenerated for the set time C (fixed), determined by the selected operating cycle (see Table 6-2). At the end of the regeneration phase, tower B is re-pressurized and kept in stand-by until the DewPoint meter (PDP Meter) indicates that the nominal value has been

reached in the tower (SPC) and activates the SHDC-2100 device for the switching of the towers. The process is repeated in the same way when tower B is operating.

	Low Pressure		High Pressure	
	-20°C/-4°F	-40°C/-40°F	-20°C/-4°F	-40°C/-40°F
Time A = C [s]	355	240	270	180
Minimum value Time B1 and D1 [s]	95	60	180	120

Even if the DewPoint found is lower than the set SPC value; the towers switch every 30 minutes. If the applied load is close to the nominal load, the SHDC-2100 device automatically moves to FIX mode (the LED OFIX shows that this mode has been enabled,

and it remains on together with the LED ODPD), and returns to DPD mode when the DewPoint values drop again below the SPC value.

	To better control the DPD cycle, the DewPoint value is calculated in the middle section of each tower. Of course the measured value is higher than the DewPoint at the outlet of the dryer.
	In case of defects and/or troubles with the PDP Meter, the SHDC-2100 device automatically enters FIX mode.

6.11 TEST

The dryer can operate following a diagnostic cycle, with step-by-step operation, to make troubleshooting or ordinary maintenance easier.

Through this operating cycle the dryer runs the nine phases (from step 1 to step 9) that form the entire operating cycle.

To access the TEST modality first set the relating DIP-SWITCHES (DIP D1 and DIP D2) to position ON; this condition will be displayed by the flashing

“OTEST” LED on the “Cycle mode” menu of the instrument. The first LED indicating the first step

lights up on the DISPLAY; by pressing the  key, the dryer moves onto the following step until it









reaches step 10. By pressing the key again , the dryer moves onto , the dryer starts from step 1 again.

Table 6-3 shows the various steps of the dryer.

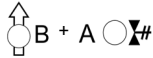
Table 6-3: Dryer Steps

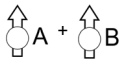
10	—10	All the LEDs	Check operation of LEDs of SHDC-2100 device					
9	—9		Line Pressure	Line Pressure	Closed	Closed	Not powered	Not powered
8	—8		< 0.3 barg	Line Pressure	Open	Closed	Powered	Not powered
7	—7		Line Pressure	Line Pressure	Closed	Closed	Not powered	Not powered
6	—6		Line Pressure	Line Pressure	Closed	Closed	Not powered	Not powered
5	—5		Line Pressure	Line Pressure	Closed	Closed	Not powered	Not powered
4	—4		Line Pressure	< 0.3 barg	Closed	Open	Not powered	Powered
3	—3		Line Pressure	Line Pressure	Closed	Closed	Not powered	Not powered
2	—2		Line Pressure	Line Pressure	Closed	Closed	Not powered	Not powered
1	—1	No LED	Start diagnostic cycle					
STEP	LED On on DISPLAY	[On]	A	B	PVA	PVB	PVA	PVB
		Status of LED	Status of towers		Purge solenoid valve		Purge solenoid valve coil	

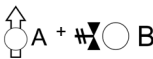
6.12 MAINTENANCE (SERVICE)

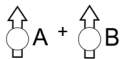
The adsorption dryer requires a periodical maintenance which, in the proposed configuration, entails the replacement of the inlet and outlet filter and of the desiccant material. Through DIP D5 it is possible to choose the foreseen use of the machine: on OFF up to 3000 hours/year, on ON over 3000

hours/year.

The SHDC-2100 device will then count the number of working hours and will engage the maintenance alarms, or better reminders, when certain values are reached. See *Table 6-4*:

Table 6-4: Maintenance Schedule

	DIP D5 = OFF		DIP D5 = ON	
	Alarm	Following Reminder	Alarm	Following Reminder
Filter IN	Every 3000 hours	Every 600 hours	Every 4000 hours	Every 800 hours
Filter OUT				
Desiccant Material	Every 9000 hours	Every 1000 hours	Every 12000 hours	Every 1500 hours

The maintenance alarms (reminder) do not change in any way the operation of the SHDC-2100 device.

6.13 FUSES

Three different safety fuses are fitted on the electronic board, in positions F1, F2 and F3. the fuses protect the following circuits:

F1 = (2A type) → main power;

F2 = (1A type) → Condensate drain solenoid valve;

F3 = (0.5A type) → control Logic.



The fuses can fail if there are any problems with the dryer. In this case, replace them, after solving the problem that caused the malfunctioning. Also

refer *Section 7.2: TROUBLESHOOTING on page 44*".

6.14 DEWPOINT METER— (OPTIONAL)

The SHDC-2100 device has an analog input 4-20mA which the DewPoint meter is connected to (PDP Meter) and a sampling system.

By installing the DewPoint meter it is possible to :

- Show the Dew Point value on the display of the SHDC-2100 device;
- Enable the operation of the dryer in DPD mode (see *Section 6.10.2*);
- Enable the HI PDP alarm (see v).

The sampling system includes a cell (Pos. 2) which holds the DewPoint meter's sensor (PDP Meter). A

constant flow of compressed air must flow through the cell (about 2 liters/minute), taken from the operating tower. The selector valve (Pos. 1) is used to choose the operating tower from which to take the air to be measured. The quantity is controlled by the air flow adjuster (Pos. 3).

The sampling system includes a cell (Pos. 2) which holds the DewPoint meter's sensor (PDP Meter). A constant flow of compressed air must flow through the cell (about 2 liters/minute), taken from the operating tower. The selector valve (Pos. 1) is used to choose the operating tower from which to take the air to be measured. The quantity is controlled by the air flow adjuster (Pos. 3).

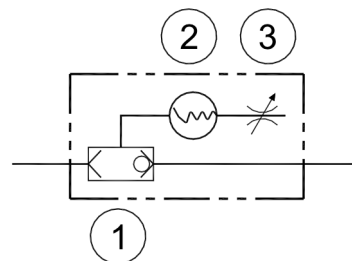

1. Working tower selector valve
2. Sampling cell with DewPoint meter
3. Air flow adjuster

Figure 6-8: DewPoint Meter layout

6.15 PDP ANALOG SIGNAL

In the standard installation, the analog signal supplied by the PDP translator is used only by the SHDC-2100 instrument. The user has the option to use the analog signal 4-20mA for any other operation (such as the monitoring of the humidity level, etc).

Hence, just simply put the mA meter on terminal S of the SHDC-2100 device, as shown in the following illustration. The signal variation ranges between 4mA (-80°C) and 20mA (+20°C), whereas the measurement range of the device is reliable in the interval between -60°C and +20°C.

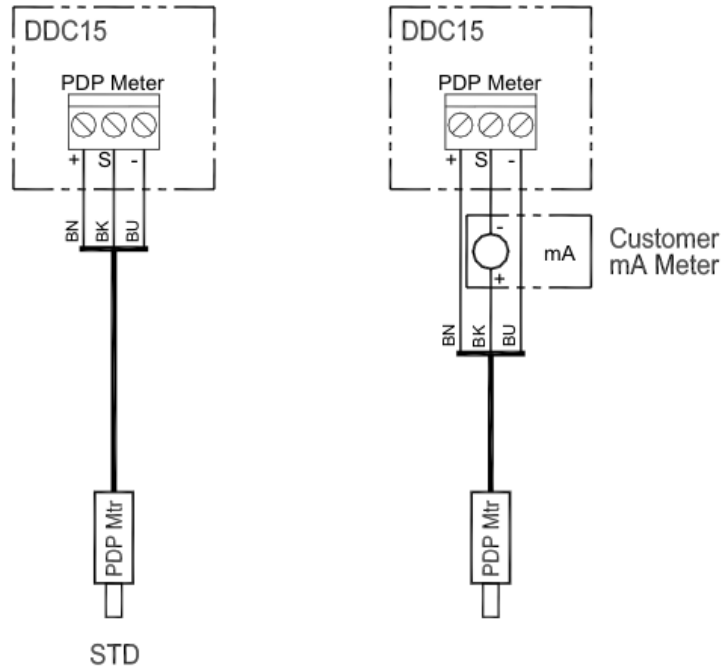

Figure 6-9: PDP Analog output for External Monitoring

6.16 PRESSURE SWITCHES OF “FAIL TO SWITCH ALARM”— (OPTIONAL)

A pressure switch is installed on each tower (PSA and PSB respectively) to enable the “FAIL TO SWITCH ALARM” function of the SHDC-2100 device. The PSA pressure switch is closed when tower A is under pressure and PSB is closed when tower B is under pressure. The system is able to detect an alarm condition if, for any reason, the flow between the two towers was not switched or the switching was not done correctly.

The “Fail to Switch alarm” function is enabled by positioning the DIP U2 on ON (also refer to *Section 6.9*).

- Point 0 : PSA must already be closed, whereas PSB must open in a maximum time of 10 seconds.
- Point 1/2 : PSB must already be closed, whereas PSA must open in a maximum time of 10 seconds.
- Point 1 = Point 0 (the cycles are repetitive).

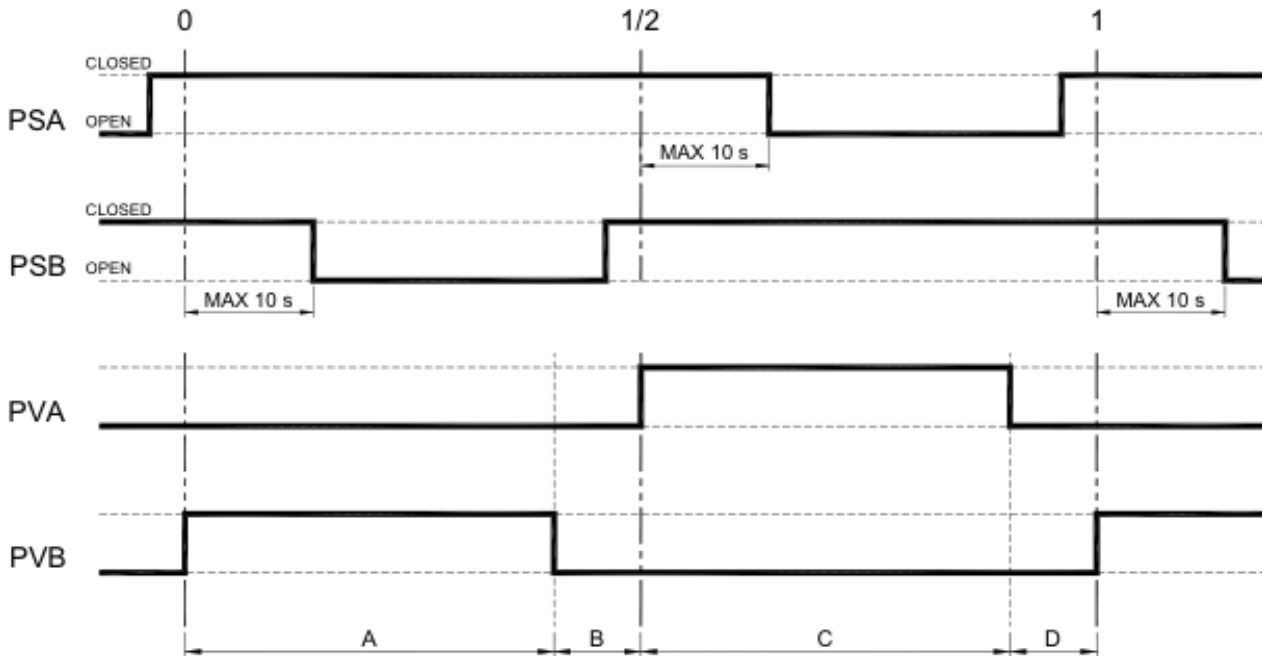

Figure 6-10: Failure to Switch Timing Sequence Diagram

6.17 CALIBRATION PRESSURES

The calibration values of the pressure switches are indicated below:







Dryer operating pressure:		Pressure switch closing pressure:		Pressure switch opening pressure:	
[barg]	[psig]	[barg]	[psig]	[barg]	[psig]
4 - 5,9	58 - 86	≥ 3	≥ 43,5	≤ 1	≤ 14,5
6 - 8,9	87 - 129	≥ 4	≥ 58	≤ 1	≤ 14,5
9 - 11,9	130 - 173	≥ 6	≥ 87	≤ 1	≤ 14,5
> 12	> 174	≥ 8	≥ 116	≤ 1	≤ 14,5

NOTES

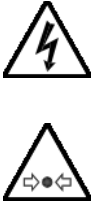

Section 7

MAINTENANCE, TROUBLESHOOTING, SPARES AND DISMANTLING





7.1 CONTROLS AND MAINTENANCE









	<p>The maintenance operations must be worked out by qualified personnel. Before any intervention, verify that:</p> <ul style="list-style-type: none"> • No part of the machine is powered and that it cannot be connected to the main power supply. • No part of the machine is under pressure and that it cannot be connected to the compressed air system.
	<p>The user that intervenes to the machine must wear hearing protection before to operate into the dryer. Each employee must select proper PPD (Personal Protection Device) hearing protector (earmuffs, ear canal caps and earplugs) in order to prevent any uneasiness that could cause dangerous situation for him.</p>
	<p>DAILY</p> <ul style="list-style-type: none"> • Check if the inlet filter condensate drain works regularly. • Check the clogging state of the filters by reading the differential pressure gauge installed. • Check that the tower switching operation takes place correctly and in the set cycle times. • Check that the differential pressure gauge, of the regenerating tower, indicates 0 bar.
	<p>YEARLY – 3000 HOURS</p> <ul style="list-style-type: none"> • Replace the inlet and outlet filter cartridge. • Clean the silencers or if necessary replace them. • Check if the regeneration drain solenoid valves (PVA e PVB) work regularly. • Check if all screws of the electrical wiring are correctly tightened. • After the checking operating, control the working of the dryer.
	<p>EVERY 2 YEARS – 6000 HOURS In addition to the programmed maintenance, every year:</p> <ul style="list-style-type: none"> • Replace the membrane of the regeneration drain solenoid valves (PVA and PVB). • Replace the techno-polymer of the shuttle spool valves. • After the control operation, control the working of the dryer.
	<p>EVERY 3 YEARS – 9000 HOURS</p> <ul style="list-style-type: none"> • Replace the adsorption material. The estimated average life of the adsorption material is 3-5 years, with 10-minute cycle times and 3000 hours/year in any case it depends on the quality and temperature of the inlet air and on the correct programmed maintenance.

7.2 TROUBLESHOOTING

	<p>The troubleshooting and the eventual checks have to be performed by qualified personnel.</p> <p>We suggest enabling the TEST modality to make troubleshooting operations easier (see Section 6.11) and gradually verify that the operating steps are performed correctly.</p>
	<p>Maintenance personnel must wear hearing protection while operating the dryer. Each employee must select proper PPD (Personal Protection Device) hearing protector (earmuffs, ear canal caps and ear-plugs) in order to prevent any discomfort or damage to the operator’s hearing..</p>



PROBLEM	POSSIBLE CAUSE - SUGGESTED ACTION
<p>Humidity in outlet air.</p>	<ul style="list-style-type: none"> • The dryer is off—switch it on. • The dryer has just been started up and the adsorption material can contain humidity—use the dryer at a reduced nominal flow of 50% for at least 2 days and verify the correct operation of the machine. • The dryer does not perform the switching cycles—see specific point. • The inlet air is too hot - restore the nominal conditions. • The inlet air pressure is too low—verify that the installed regeneration nozzle is for the real working pressure of the dryer. If you have doubts or problems, please contact your distributor. • The inlet air flow rate is higher than the rate of the dryer—reduce the flow rate —restore the nominal conditions. • Inlet filter does not drain the condensate—check the proper operation of the drainer. • Electronic timer of the inlet filter drainer is not adjusted correctly—reduce the drain pause time. • The pressure gauge of the tower under regeneration shows a pressure higher than 0—silencers are clogged—clean or replace them. • Cycle time on SHDC-2100 Electronic Controller has been modified—restore the nominal times. • Desiccant material is exhausted—replace.
<p>Solenoid valve PVA and/or PVB are never activated.</p>	<ul style="list-style-type: none"> • Check for electrical supply or on/off switch failure. • Verify the electric wiring. • Verify fuses on SHDC-2100 Electronic Controller. • The valve is blocked—open and clean it. • The coil of the solenoid valve burned out—replace it.

PROBLEM	POSSIBLE CAUSE - SUGGESTED ACTION
Dryer does not perform the switching cycles.	<ul style="list-style-type: none"> • Solenoid valve PVA and/or PVB are never activated - see specific point. • Inlet and/or outlet shuttle spool valve is blocked – carry out maintenance operations.
All the inlet air is discharged through the silencers.	<ul style="list-style-type: none"> • The dryer does not perform the switching cycles—see specific point. • The solenoid valve PVA and/or PVB is blocked—open and clean it. • The membrane of solenoid valve PVA and/or PVB is broken—carry out maintenance operations. • The SHDC-2100 Electronic controller always supplies solenoid valve PVA and/or PVB – verify the electric wiring and if necessary replace. • The cycle times on the SHDC-2100 electronic controller have been changed—restore nominal conditions. • Regeneration nozzle is clogged—open and clean it.
Liquid comes out of the silencers.	<ul style="list-style-type: none"> • Humidity in outlet air – see specific point.
LED   “HI PDP” of the SHDC-2100 device flashes or is on.	<p>The probe of the DewPoint Meter (optional) detects a high DewPoint, for one of the following reasons:</p> <ul style="list-style-type: none"> • Humidity at dryer outlet—see specific point. • The air flow adjuster setting has been changed (see <i>Section 6.14</i>)—reset nominal value. • The selector valve of the operating tower (see <i>Section 6.14</i>) is blocked—replace it. • Verify the electric connection of the probe. • The probe is not calibrated—contact the dealer. • The probe is broken—replace it. • There is an air leak on the pipes and/or joints that connect the equipment— verify the connections and replace the damaged parts. • A pipe or a joint which connects the equipment is clogged—replace it.
The LED   “FAIL TO SWITCH” of the SHDC-2100 device flashes or is on.	<p>The pressureswitches(optional)forthe“FAILTOSWITCH”function,show an anomalous conditions during the tower switching process, for one of the following reasons:</p> <ul style="list-style-type: none"> • The dryer does not run the switching cycle – see specific point. • All the inlet air is purged through the silencers – see specific point. • The solenoid valve PVA and/or PVB is never enabled – see specific point. • The pressure switches are not calibrated – reset the default settings (see <i>Section 6.17</i>). • There is an air leak on the pipes and/or joints that connect the equipment –verify the connections and replace the damaged parts. • A pipe or a joint which connects the equipment is clogged – replace it.

PROBLEM	POSSIBLE CAUSE - SUGGESTED ACTION
<p>The LED   "SERVICE" of the SHDC-2100 device flashes or is on.</p>	<p>The dryer needs maintenance (also refer to <i>Section 6.6</i> and <i>Section 7.1</i>), more precisely :</p> <ul style="list-style-type: none"> • If the LED "SERVICE" flashes together with the LED , it means that the inlet filter of the dryer is clogged – replace the filtering element (cartridge). • If the LED "SERVICE" flashes together with the LED , it means that the outlet filter of the dryer is clogged – replace the filtering element (cartridge). • If the LED "SERVICE" flashes together with both LEDs  -  the filter programmed maintenance timer went off – replace the filtering elements (cartridges). • If the LED "SERVICE" flashes together with both LEDs  A -  B the adsorbent material programmed maintenance timer went off – replace the desiccant bed.

7.3 DISMANTLING OF THE DRYER

If the dryer is to be dismantled, it has to be split into homogeneous groups of materials.

	Part	Material
	Desiccant material	Activated Alumina or molecular sieve optional
	Frame and supports	Carbon steel
	Piping	Carbon steel
	Towers and diffuser	Carbon steel, Stainless steel
	Bi-Directional Inlet valve	Aluminum Alloy, Techno-polymer
	Filter housing	Aluminum
	Filter cartridge	Filtering material, PVC, Oil
	Solenoid valve	Bronze
	Condensate Drain	Bronze
	Silencers	Aluminum
	Safety Valves	Brass
	Gaskets and O-Ring	Graphite, synthetic elastomer
	Electric cables	Copper, PVC
	Electric Parts	PVC, Copper, Bronze
	<p>We recommend to comply with the safety rules in force for the disposal of each type of material. The adsorption material and the filter cartridge contains droplets of lubrication oil. Do not dispose these materials in the environment. Delivered it to a collection centre.</p>	

Section 8

ATTACHMENTS

8.1 ID—DHL80-125

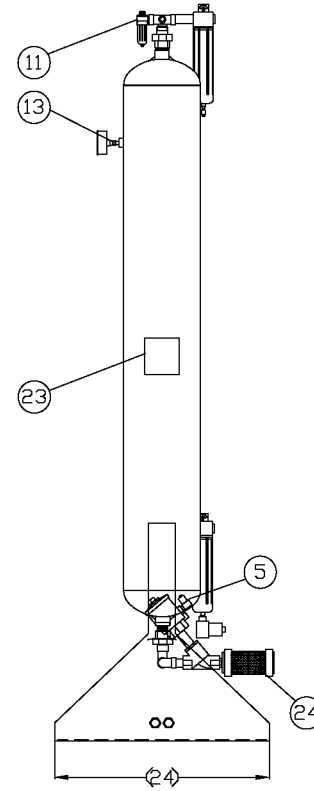
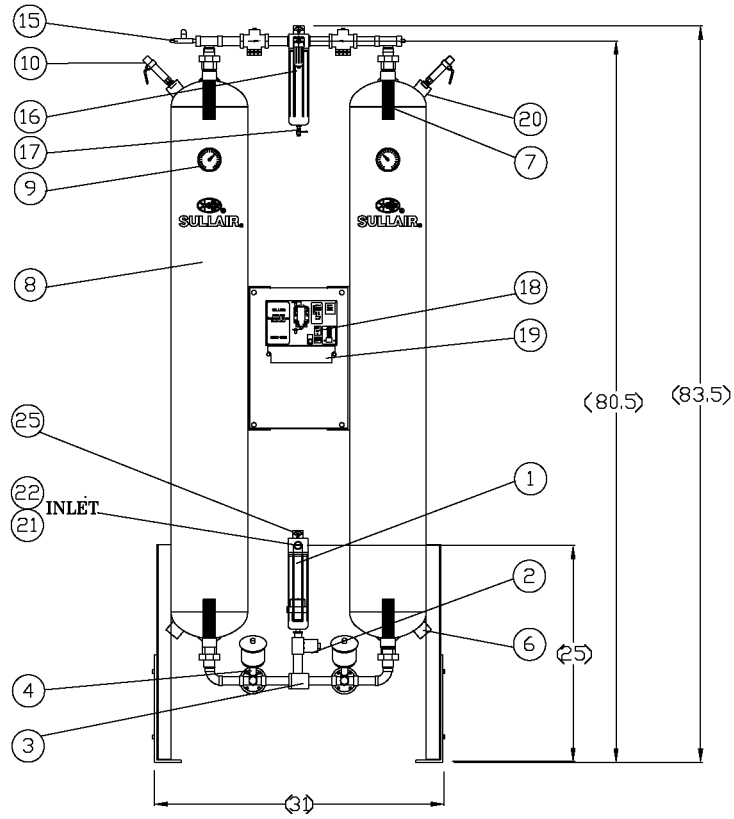
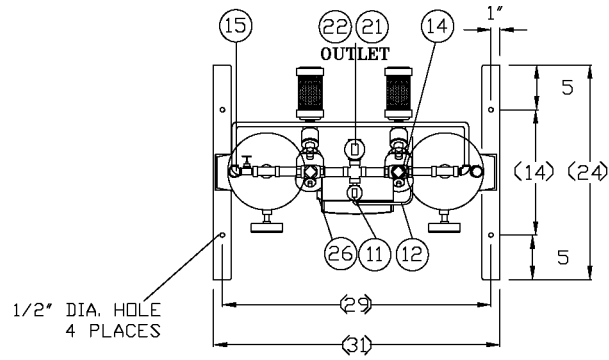

02250195-329

8.1 ID—DHL80-125

ITEM	QTY	DESCRIPTION
1	1	COALESCING PRE-FILTER
2	1	PRE-FILTER ELECTRONIC DRAIN VALVE
3	1	BI-DIRECTIONAL PURGE ADJUSTMENT VALVE
4	2	ANGLE BODY PURGE EXHAUST VALVE
5	2	PURGE PILOT VALVE
6	2	DESICCANT DRAIN PORT (1" NPT)
7	4	STAINLESS STEEL DEFUZER
8	2	PRESSURE VESSELS
9	2	PRESSURE GUAGE
10	2	PRESSURE RELIEF VALVE (SET @ 200 PSIG)
11	2	CONTROL AIR FILTER
12	1	CONTROL AIR TUBING (1/4")
13	2	GAUGE SNUBBER
14	2	OUTLET CHECK VALVE
15	1	PURGE ADJUSTMENT VALVE
16	1	AFTER FILTER PARTICULATE TYPE
17	1	MANUAL DRAIN BALL VALVE
18	1	DRYER CONTROLLER
19	1	ELECTRICAL ENCLOSURE COVER
20	2	DESICCANT FILL PORT (1" NPT)
21	2	INLET/OUTLET CONNECTIONS: 3/4" NPT (80 CFM)
22	2	INLET/OUTLET CONNECTIONS 1"NPT (100 & 125 CFM)

ITEM	QTY	DESCRIPTION
23	2	ASME & CRN TAG
24	2	PURGE EXHAUST MUFFLE
25	2	PRESSURE DIFFERENTIAL INDICATOR
26	1	POWER ON/OFF SWITCH

8.2 ID—DHL150-200

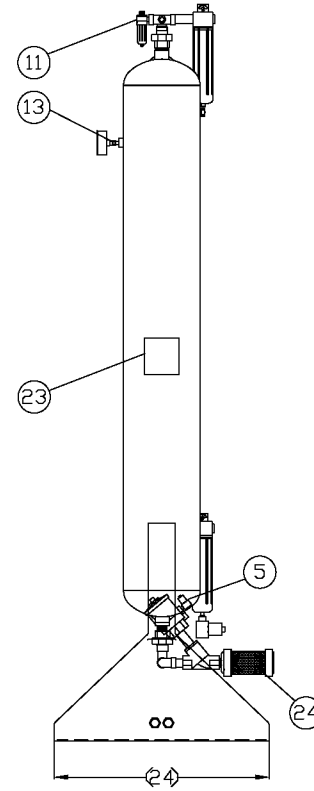
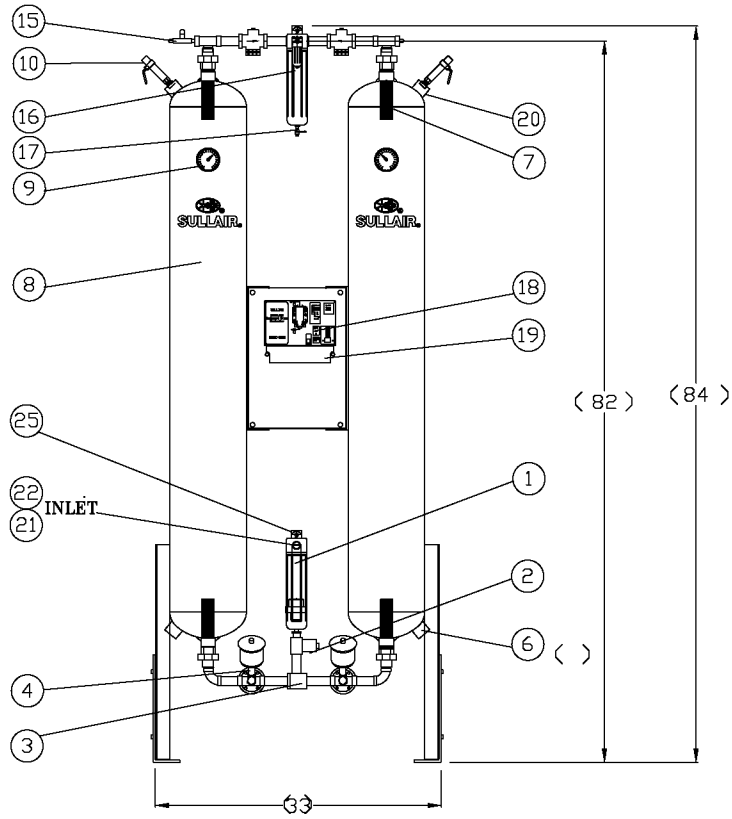
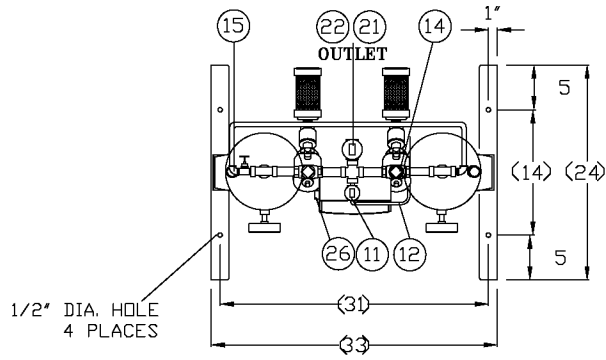

02250195-330

8.2 ID—DHL150-200

ITEM	QTY	DESCRIPTION
1	1	COALESCING PRE-FILTER
2	1	PRE-FILTER ELECTRONIC DRAIN VALVE
3	1	BI-DIRECTIONAL PURGE ADJUSTMENT VALVE
4	2	ANGLE BODY PURGE EXHAUST VALVE
5	2	PURGE PILOT VALVE
6	2	DESICCANT DRAIN PORT
7	4	STAINLESS STEEL DEFUZER
8	2	PRESSURE VESSELS
9	2	PRESSURE GUAGE
10	2	PRESSURE RELIEF VALVE (SET @ 200 PSIG)
11	2	CONTROL AIR FILTER
12	1	CONTROL AIR TUBING (1/4")
13	2	GAUGE SNUBBER
14	2	OUTLET CHECK VALVE
15	1	PURGE ADJUSTMENT VALVE
16	1	AFTER FILTER PARTICULATE TYPE
17	1	MANUAL DRAIN BALL VALVE
18	1	DRYER CONTROLLER
19	1	ELECTRICAL ENCLOSURE COVER
20	2	DESICCANT FILL PORT (1" NPT)
21	2	INLET/OUTLET CONNECTIONS: 3/4" NPT (150 CFM)
22	2	INLET/OUTLET CONNECTIONS 1"NPT (200 CFM)
23	2	ASME & CRN TAG

ITEM	QTY	DESCRIPTION
24	2	PURGE EXHAUST MUFFLE
25	2	PRESSURE DIFFERENTIAL INDICATOR
26	1	POWER ON/OFF SWITCH

8.3 ID—DHL250-300

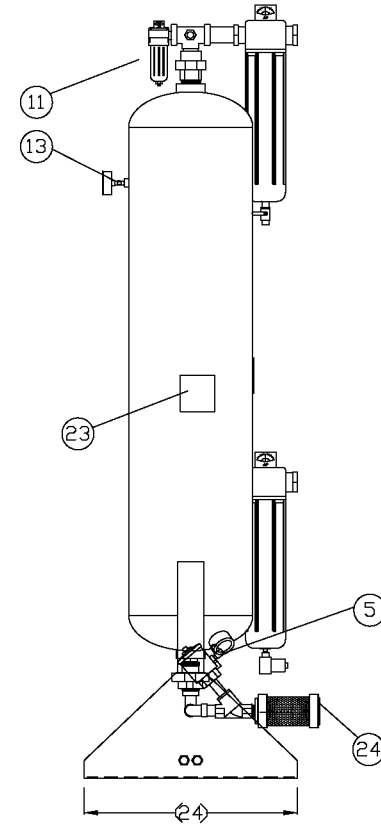
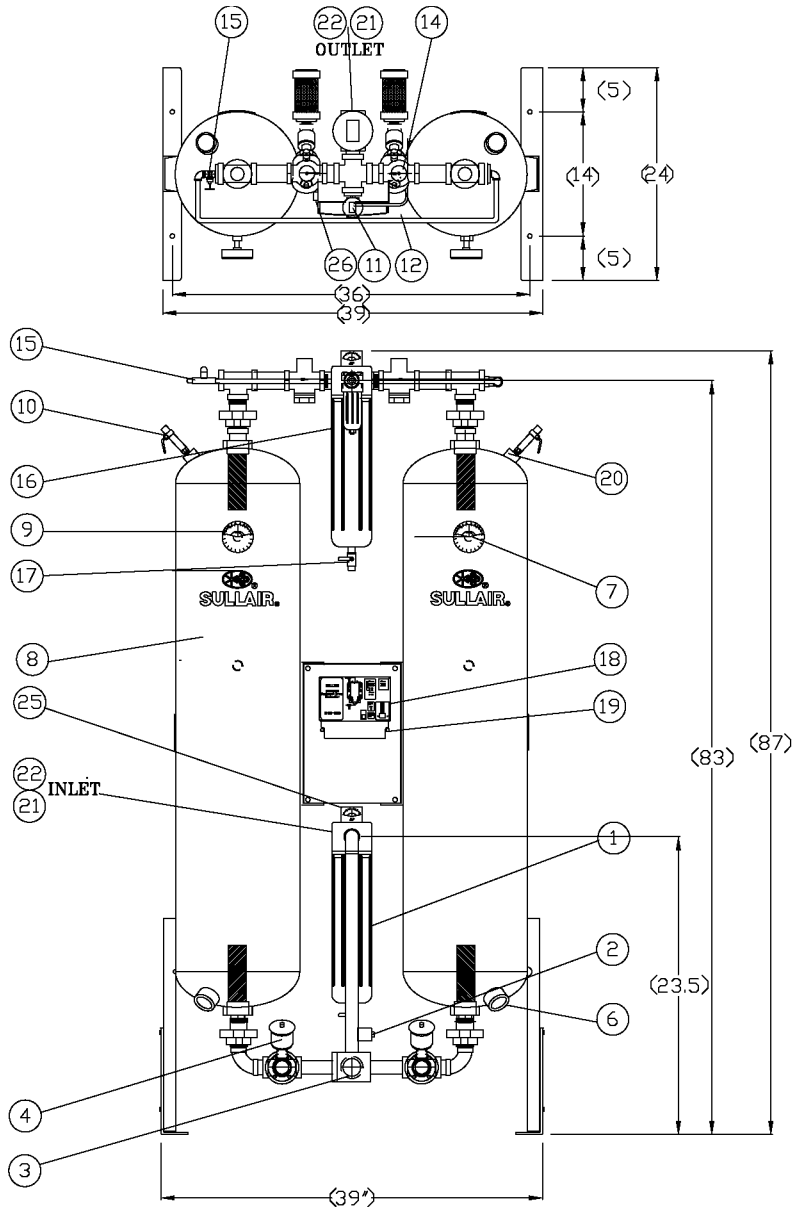

8.3 ID—DHL250-300

ITEM	QTY	DESCRIPTION
1	1	COALESCING PRE-FILTER
2	1	PRE-FILTER ELECTRONIC DRAIN VALVE
3	1	BI-DIRECTIONAL PURGE ADJUSTMENT VALVE
4	2	ANGLE BODY PURGE EXHAUST VALVE
5	2	PURGE PILOT VALVE
6	2	DESICCANT DRAIN PORT
7	4	STAINLESS STEEL DEFUZER
8	2	PRESSURE VESSELS
9	2	PRESSURE GUAGE
10	2	PRESSURE RELIEF VALVE (SET @ 200 PSIG)
11	2	CONTROL AIR FILTER
12	1	CONTROL AIR TUBING (1/4")
13	2	GAUGE SNUBBER
14	2	OUTLET CHECK VALVE
15	1	PURGE ADJUSTMENT VALVE
16	1	AFTER FILTER PARTICULATE TYPE
17	1	MANUAL DRAIN BALL VALVE
18	1	DRYER CONTROLLER
19	1	ELECTRICAL ENCLOSURE COVER
20	2	DESICCANT FILL PORT (1" NPT)
21	2	INLET/OUTLET CONNECTIONS: 3/4" NPT (250 CFM)
22	2	INLET/OUTLET CONNECTIONS 1"NPT (300 CFM)
23	2	ASME & CRN TAG

ITEM	QTY	DESCRIPTION
24	2	PURGE EXHAUST MUFFLE
25	2	PRESSURE DIFFERENTIAL INDICATOR
26	1	POWER ON/OFF SWITCH

8.4 ID—DHL400-600

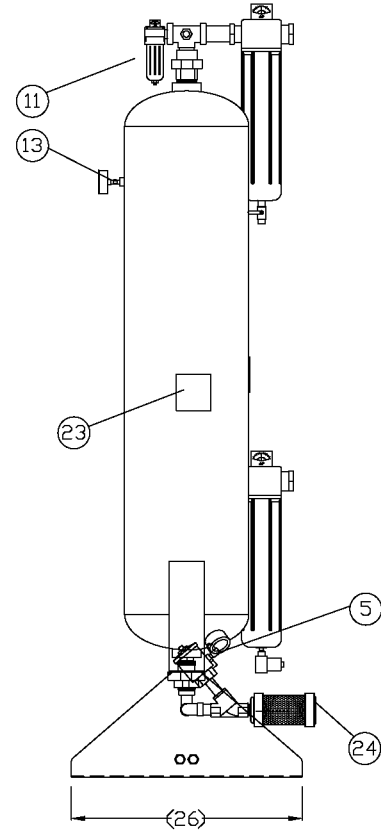
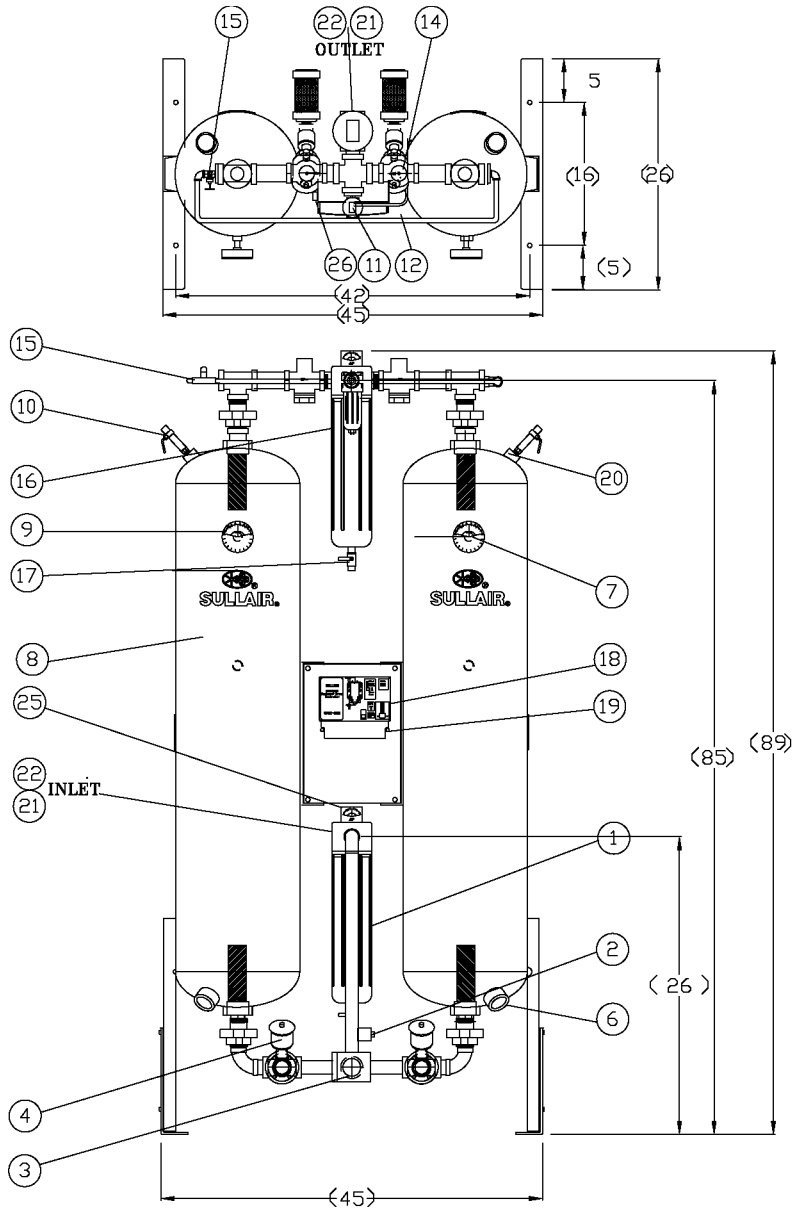

02250195-332

8.4 ID—DHL400-600

ITEM	QTY	DESCRIPTION
1	1	COALESCING PRE-FILTER
2	1	PRE-FILTER ELECTRONIC DRAIN VALVE
3	1	BI-DIRECTIONAL PURGE ADJUSTMENT VALVE
4	2	ANGLE BODY PURGE EXHAUST VALVE
5	2	PURGE PILOT VALVE
6	2	DESICCANT DRAIN PORT
7	4	STAINLESS STEEL DEFUZER
8	2	PRESSURE VESSELS
9	2	PRESSURE GUAGE
10	2	PRESSURE RELIEF VALVE (SET @ 200 PSIG)
11	2	CONTROL AIR FILTER
12	1	CONTROL AIR TUBING (1/4")
13	2	GAUGE SNUBBER
14	2	OUTLET CHECK VALVE
15	1	PURGE ADJUSTMENT VALVE
16	1	AFTER FILTER PARTICULATE TYPE
17	1	MANUAL DRAIN BALL VALVE
18	1	DRYER CONTROLLER
19	1	ELECTRICAL ENCLOSURE COVER
20	2	DESICCANT FILL PORT (1" NPT)
21	2	INLET/OUTLET CONNECTIONS: 3/4" NPT (400-500 CFM)
22	2	INLET/OUTLET CONNECTIONS 1"NPT (600 CFM)

ITEM	QTY	DESCRIPTION
23	2	ASME & CRN TAG
24	2	PURGE EXHAUST MUFFLE
25	2	PRESSURE DIFFERENTIAL INDICATOR
26	1	POWER ON/OFF SWITCH

8.5 ID—DHL800-1000

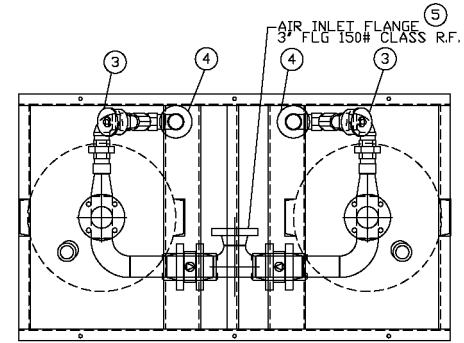
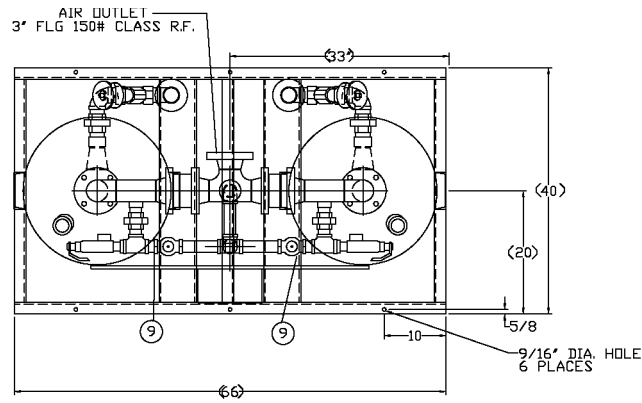

VIEW A-A
BOTTOM PIPING

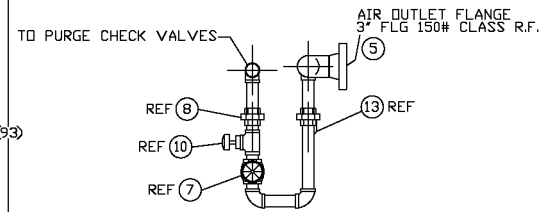
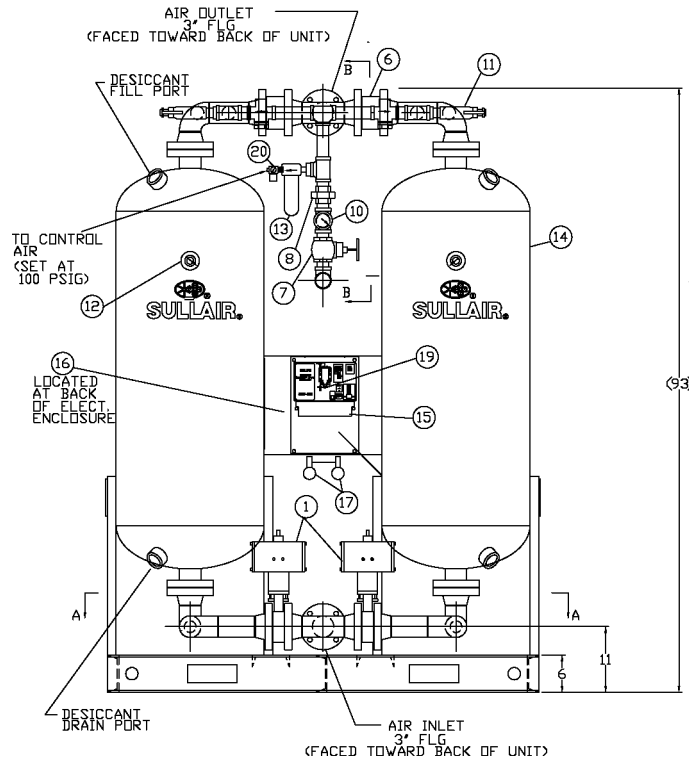

VIEW B-B
PURGE PIPING



02250195-333

8.5 ID—DHL800-1000

ITEM	QTY	DESCRIPTION
1	2	INLET VALVE WAFER STYLE BUTTERFLY VALVE HIGH PERFORMANCE, WITH DOUBLE ACTING ACTUATOR
2	4	STAINLESS STEEL DIFFUZER (INTERNAL)
3	2	PURGE EXHAUST VALVE, ANGLE BODY PISTON TYPE
4	2	PURGE EXHAUST MUFFLER
5	2	INLET/OUTLET CONNECTIONS 3" RF. FLG
6	2	OUTLET CHECK VALVE
7	1	PURGE ADJUSTMENT VALVE
8	1	ORIFICE UNION
9	2	PURGE CHECK VALVE
10	1	PURGE PRESSURE GAUGE, 0-200 PSIG
11	2	PRESSURE RELIEF VALVE SET @ 150 PSIG
12	2	TOWER PRESSURE GAUGE, 0-200 PSIG
13	1	CONTROL AIR FILTER
14	2	DESICCANT TOWER
15	1	ELECTRICAL ENCLOSURE
16	1	TOWER SELECTOR VALVE, 4-WAY, 2-POS, DUAL SOL.
17	2	PURGE EXHAUST PILOT VALVE, 3-WAY, SOLENOID OPERATED
18		(NOT USED)
19	1	SOLID STATE SEQUENCE CONTROL MODULE
20	1	CONTROL AIR REGULATOR (SET AT 100PSIG)

8.6 ID—DHL1250-1500

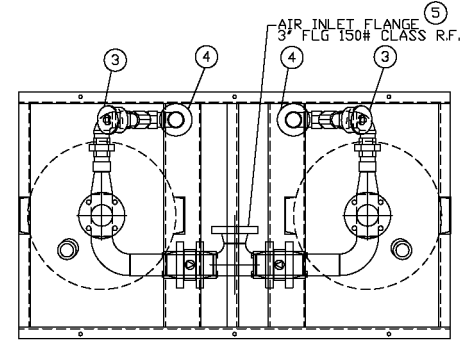
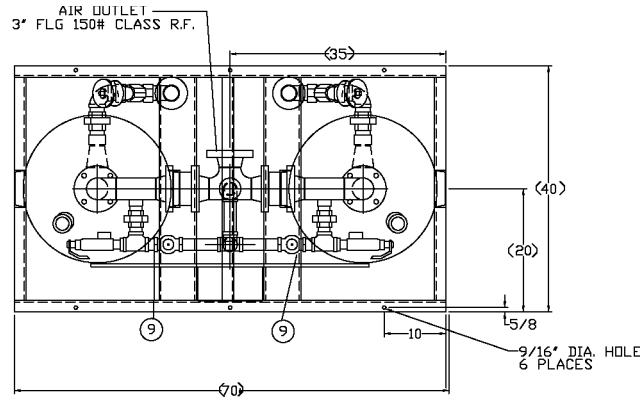

VIEW A-A
BOTTOM PIPING

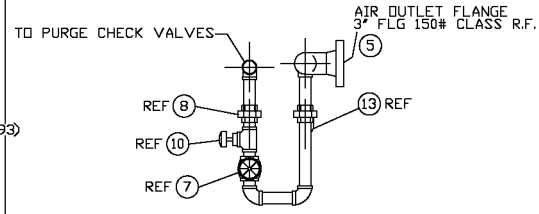
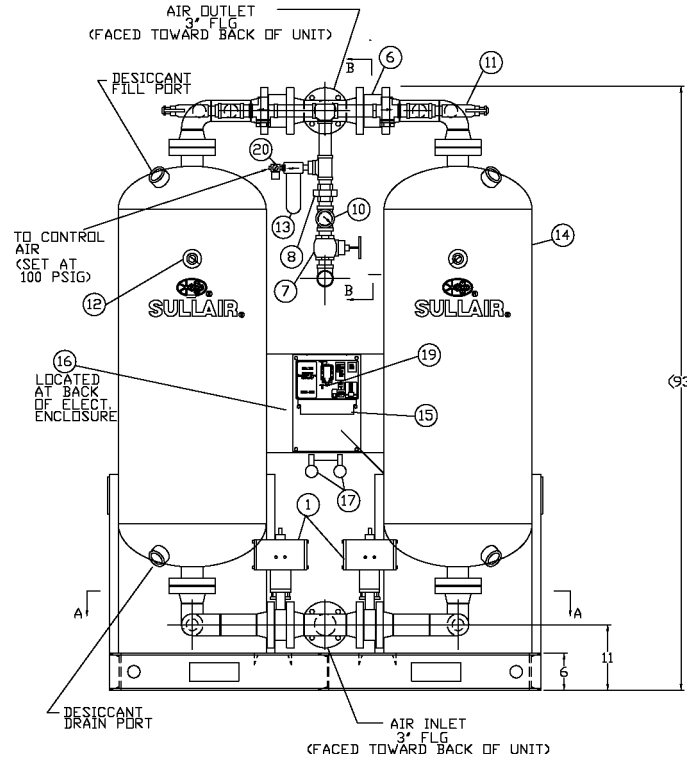

VIEW B-B
PURGE PIPING



02250195-334

8.6 ID—DHL1250-1500

ITEM	QTY	DESCRIPTION
1	2	INLET VALVE WAFER STYLE BUTTERFLY VALVE HIGH PERFORMANCE, WITH DOUBLE ACTING ACTUATOR
2	4	STAINLESS STEEL DIFFUZER (INTERNAL)
3	2	PURGE EXHAUST VALVE, ANGLE BODY PISTON TYPE
4	2	PURGE EXHAUST MUFFLER
5	2	INLET/OUTLET CONNECTIONS 3" RF. FLG
6	2	OUTLET CHECK VALVE
7	1	PURGE ADJUSTMENT VALVE
8	1	ORIFICE UNION
9	2	PURGE CHECK VALVE
10	1	PURGE PRESSURE GAUGE, 0-200 PSIG
11	2	PRESSURE RELIEF VALVE SET @ 150 PSIG
12	2	TOWER PRESSURE GAUGE, 0-200 PSIG
13	1	CONTROL AIR FILTER
14	2	DESICCANT TOWER
15	1	ELECTRICAL ENCLOSURE
16	1	TOWER SELECTOR VALVE, 4-WAY, 2-POS, DUAL SOL.
17	2	PURGE EXHAUST PILOT VALVE, 3-WAY, SOLENOID OPERATED
18		(NOT USED)
19	1	SOLID STATE SEQUENCE CONTROL MODULE
20	1	CONTROL AIR REGULATOR (SET AT 100PSIG)

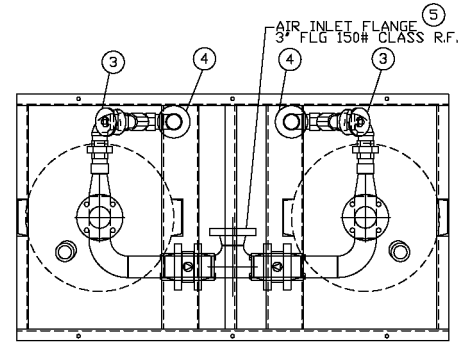
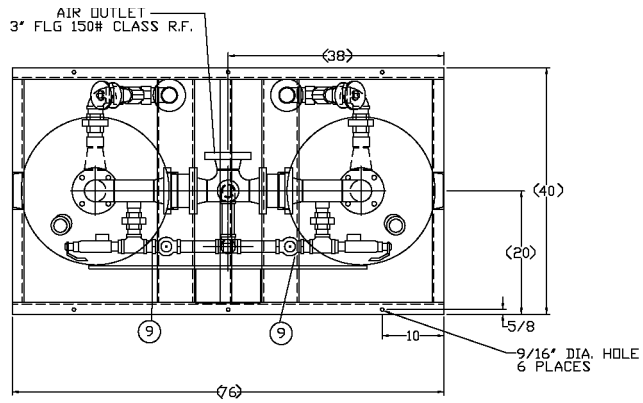

VIEW A-A
BOTTOM PIPING

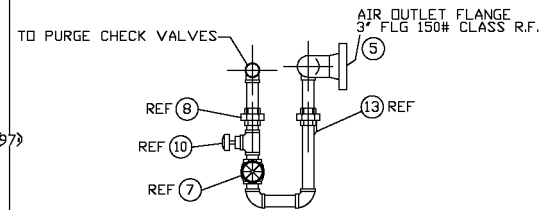
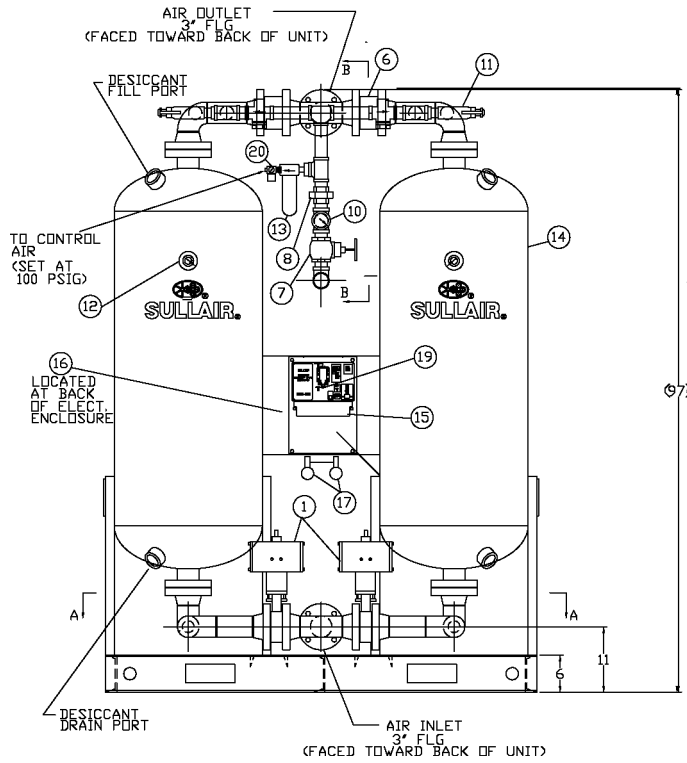

VIEW B-B
PURGE PIPING



02250195-335

8.7 ID—DHL2000

ITEM	QTY	DESCRIPTION
1	2	INLET VALVE WAFER STYLE BUTTERFLY VALVE HIGH PERFORMANCE, WITH DOUBLE ACTING ACTUATOR
2	4	STAINLESS STEEL DIFFUZER (INTERNAL)
3	2	PURGE EXHAUST VALVE, ANGLE BODY PISTON TYPE
4	2	PURGE EXHAUST MUFFLER
5	2	INLET/OUTLET CONNECTIONS 3" RF. FLG
6	2	OUTLET CHECK VALVE
7	1	PURGE ADJUSTMENT VALVE
8	1	ORIFICE UNION
9	2	PURGE CHECK VALVE
10	1	PURGE PRESSURE GAUGE, 0-200 PSIG
11	2	PRESSURE RELIEF VALVE SET @ 150 PSIG
12	2	TOWER PRESSURE GAUGE, 0-200 PSIG
13	1	CONTROL AIR FILTER
14	2	DESICCANT TOWER
15	1	ELECTRICAL ENCLOSURE
16	1	TOWER SELECTOR VALVE, 4-WAY, 2-POS, DUAL SOL.
17	2	PURGE EXHAUST PILOT VALVE, 3-WAY, SOLENOID OPERATED
18		(NOT USED)
19	1	SOLID STATE SEQUENCE CONTROL MODULE
20	1	CONTROL AIR REGULATOR (SET AT 100PSIG)

8.8 ID—DHL2500-3000

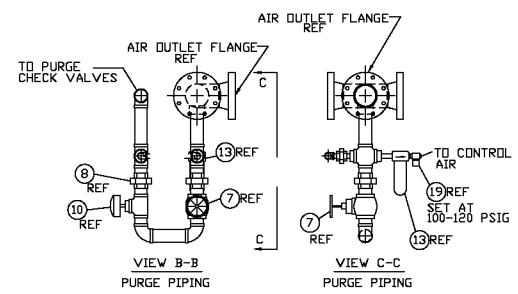
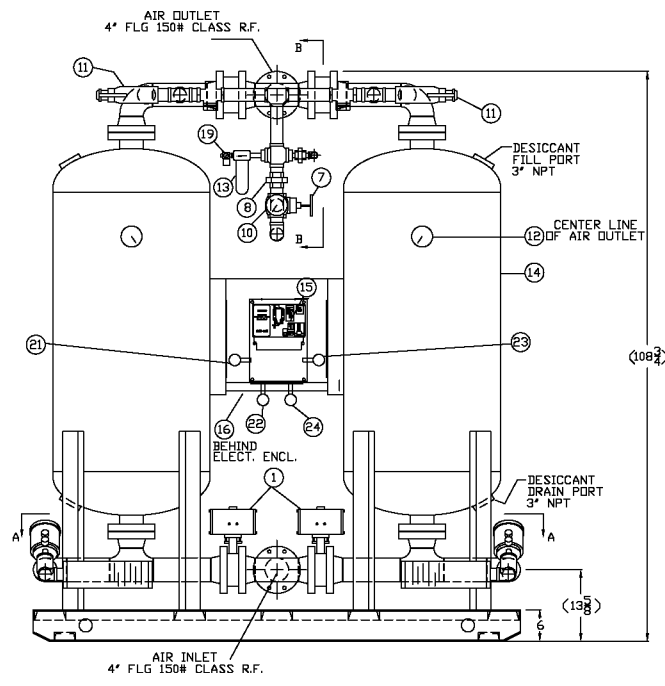
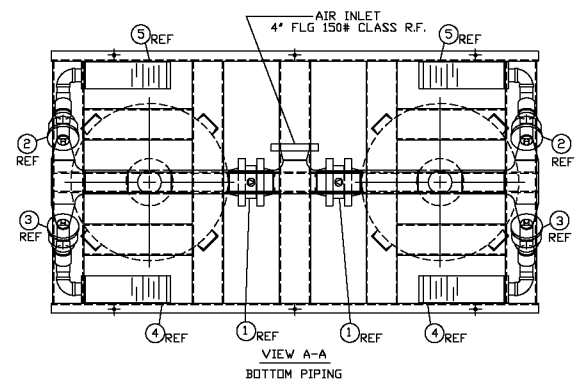
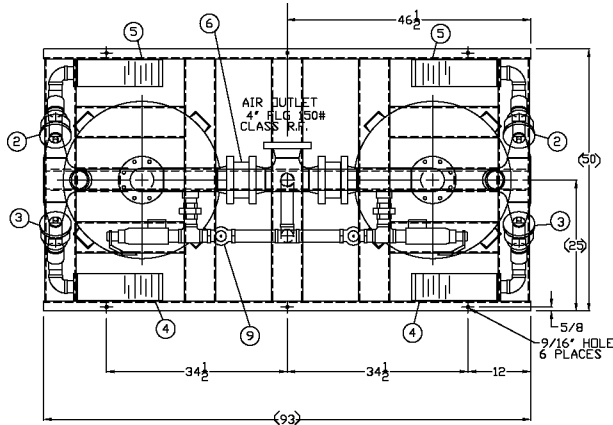

02250195-336

8.8 ID—DHL2500-3000

ITEM	QTY	DESCRIPTION
1	2	4" INLET VALVE WAFER STYLE BUTTERFLY VALVE HIGH PERFORMANCE, WITH DOUBLE ACTING ACTUATOR
2	2	2" NPT DEPRESSURIZATION VALVE, ANGLE BODY PISTON TYPE
3	2	2" NPT PURGE EXHAUST VALVE, ANGLE BODY PISTON TYPE
4	2	2" NPT PURGE EXHAUST MUFFLER
5	2	2" NPT DEPRESSURIZATION MUFFLER
6	2	4" OUTLET CHECK VALVE, WAFER STYLE
7	1	2" NPT PURGE ADJUSTMENT VALVE
8	1	2" NPT ORIFICE UNION
9	2	2" NPT PURGE CHECK VALVE
10	1	PURGE PRESSURE GUAGE, 3 1/2" DIA. 0-200 PSIG
11	2	1 1/2" NPT PRESSURE RELIEF VALVE
12	2	TOWER PRESSURE GAUGE, 3 1/2" DIA. 0-200 PSIG
13	1	CONTROL AIR FILTER
14	2	DESICCANT TOWER
15	1	ELECTRICAL ENCLOSURE
16	1	TOWER SELECTOR VALVE, 4-WAY, 2-POS, DUAL SOL.
17		(NOT USED)
18		(NOT USED)
19	1	CONTROL AIR PRESSURE REGULATOR AND GUAGE
20	1	DRAIN SOLENOID VALVE FOR PRE-FILTER

ITEM	QTY	DESCRIPTION
21	1	LEFT TOWER DEPRESSURIZATION PILOT VALVE, 3-WAY, SOLENOID OPERATED
22	1	LEFT TOWER PURGE EXHAUST PILOT VALVE, 3-WAY, SOLENOID OPERATED
23	1	RIGHT TOWER DEPRESSURIZATION PILOT VALVE, 3-WAY, SOLENOID OPERATED
24	1	RIGHT TOWER PURGE EXHAUST PILOT VALVE, 3-WAY, SOLENOID OPERATED

8.9 ID—DHL3500-4000

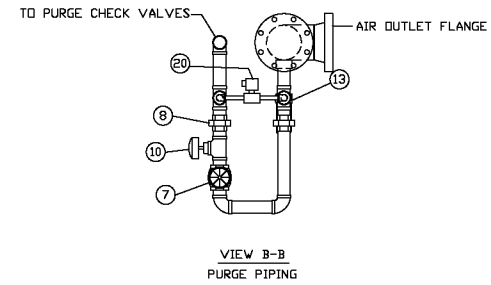
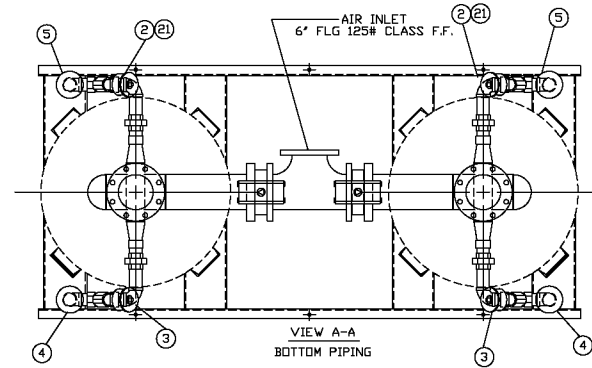
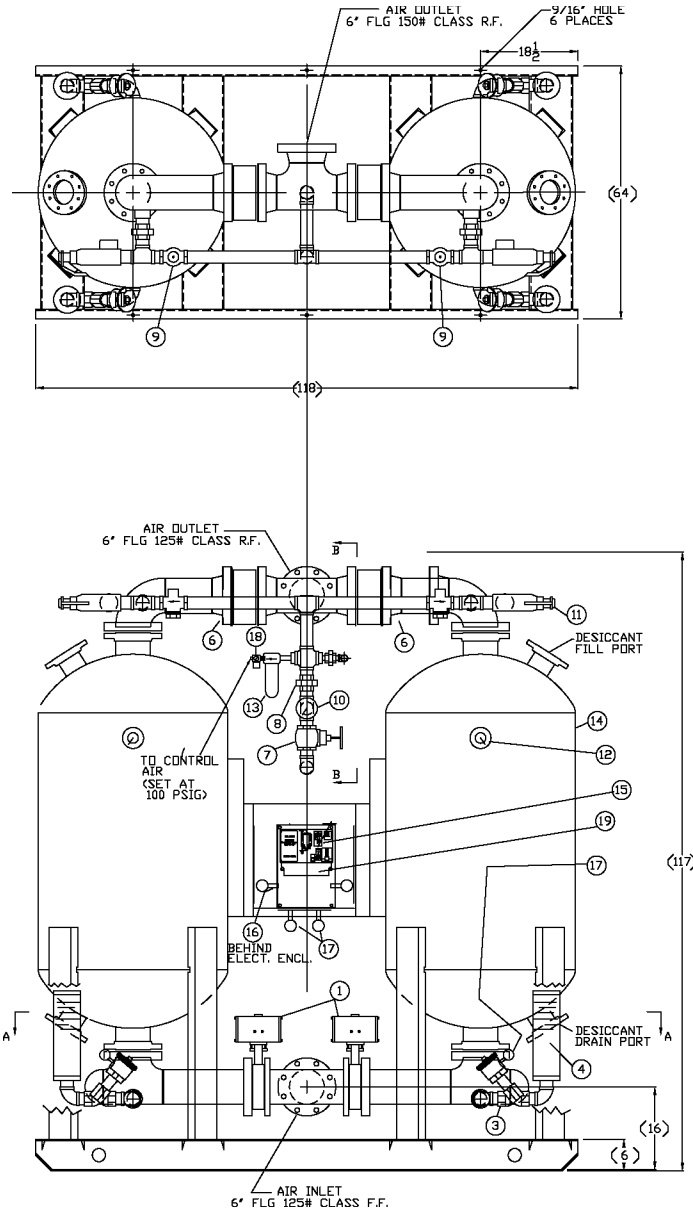

02250195-337

8.9 ID—DHL3500-4000

ITEM	QTY	DESCRIPTION
1	2	INLET VALVE WAFER STYLE BUTTERFLY VALVE HIGH PERFORMANCE, WITH DOUBLE ACTING ACTUATOR
2	2	DEPRESSURIZATION VALVE
3	2	PURGE EXHAUST VALVE
4	2	PURGE EXHAUST MUFFLER
5	2	DEPRESSURIZATION MUFFLER
6	2	OUTLET CHECK VALVE
7	1	PURGE ADJUSTMENT VALVE
8	1	ORIFICE UNION
9	2	PURGE CHECK VALVE
10	1	PURGE PRESSURE GAUGE, 0-200 PSIG
11	2	PRESSURE RELIEF VALVE
12	2	TOWER PRESSURE GAUGE, 0-200 PSIG
13	1	CONTROL AIR FILTER
14	2	DESICCANT TOWER
15	1	ELECTRICAL ENCLOSURE
16	1	TOWER SELECTOR VALVE, 4-WAY, 2-POS, DUAL SOL.
17	2	PURGE EXHAUST PILOT VALVE, 3-WAY, SOLENOID OPERATED
18	1	CONTROL AIR PRESSURE REGULATOR (SET AT 100PSIG)
19	1	SOLID STATE SEQUENCE CONTROL MODULE
20	1	REPRESSURIZATION SOLENOID VALVE
21	2	DEPRESSURIZATION PILOT VALVE, 3-WAY, SOLENOID OPERATED

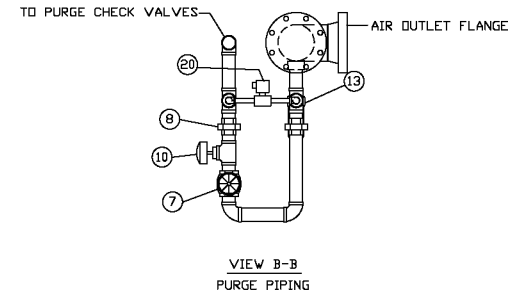
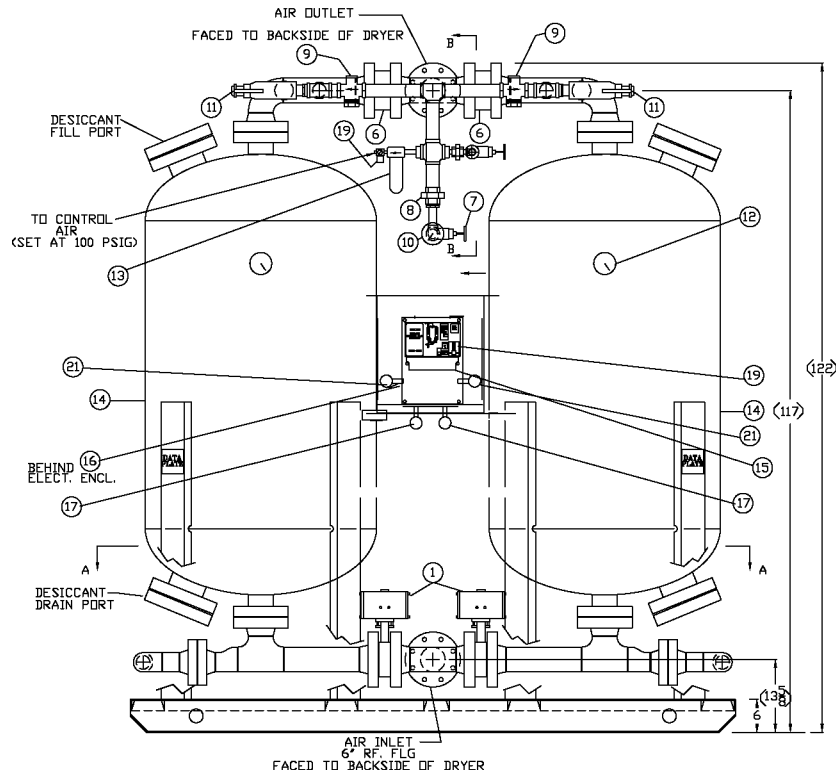
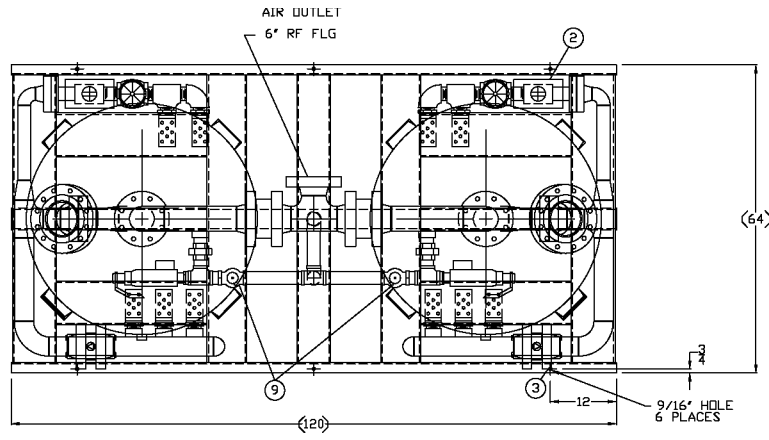

8.10 ID—DHL4000-5000



02250195-338

8.10 ID—DHL4000-5000

ITEM	QTY	DESCRIPTION
1	2	INLET VALVE WAFER STYLE BUTTERFLY VALVE HIGH PERFORMANCE, WITH DOUBLE ACTING ACTUATOR
2	2	DEPRESSURIZATION VALVE
3	2	PURGE EXHAUST VALVE
4	2	PURGE EXHAUST MUFFLER
5	2	DEPRESSURIZATION MUFFLER
6	2	OUTLET CHECK VALVE
7	1	PURGE ADJUSTMENT VALVE
8	1	ORIFICE UNION
9	2	PURGE CHECK VALVE
10	1	PURGE PRESSURE GAUGE, 0-200 PSIG
11	2	PRESSURE RELIEF VALVE
12	2	TOWER PRESSURE GAUGE, 0-200 PSIG
13	1	CONTROL AIR FILTER
14	2	DESICCANT TOWER
15	1	ELECTRICAL ENCLOSURE
16	1	TOWER SELECTOR VALVE, 4-WAY, 2-POS, DUAL SOL.
17	2	PURGE EXHAUST PILOT VALVE, 3-WAY, SOLENOID OPERATED
18	1	CONTROL AIR PRESSURE REGULATOR (SET AT 100PSIG)
19	1	SOLID STATE SEQUENCE CONTROL MODULE
20	1	REPRESSURIZATION SOLENOID VALVE
21	2	DEPRESSURIZATION PILOT VALVE, 3-WAY, SOLENOID OPERATED

LEGEND	
	CONTROL LINES
	COMPRESSED AIR LINES

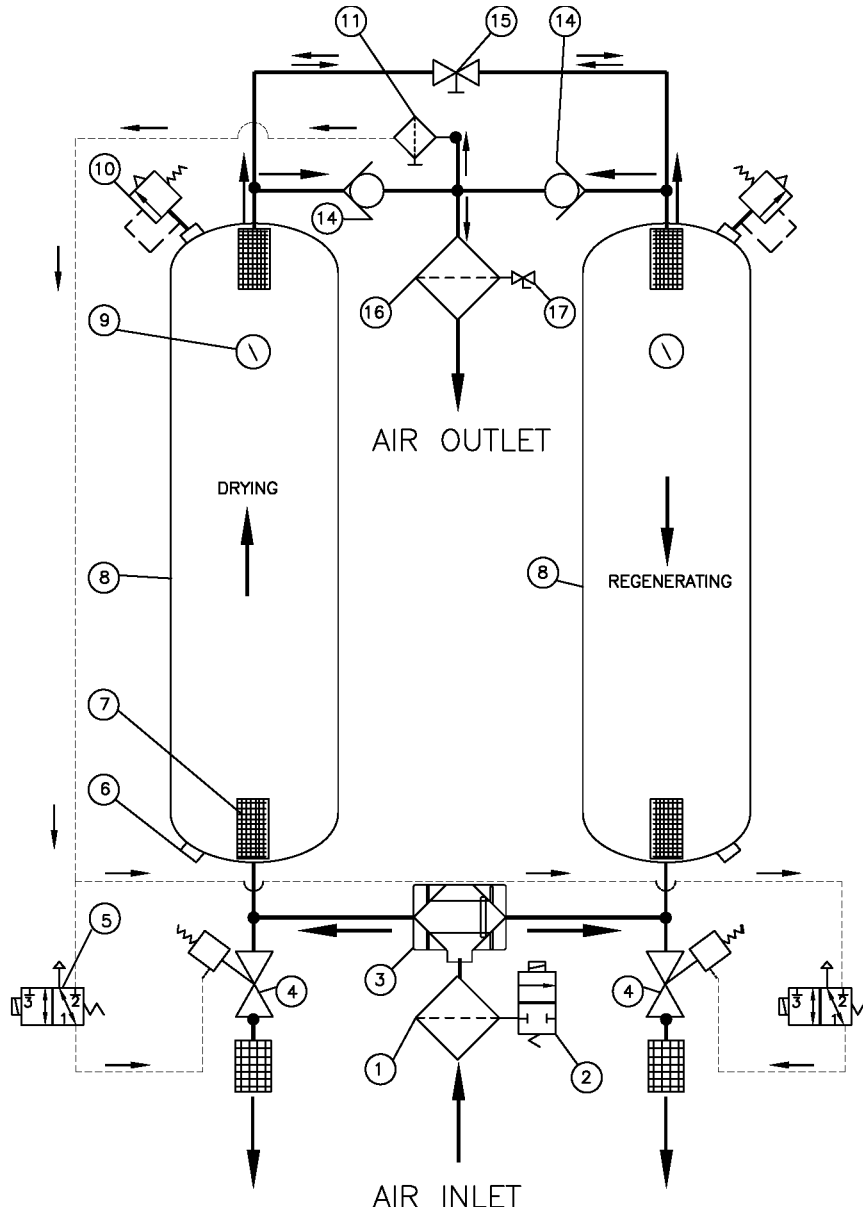

8.11 P&I—DHL80-125

ITEM	QTY	DESCRIPTION
1	1	COALESCING PRE-FILTER
2	1	PRE-FILTER ELECTRONIC DRAIN VALVE
3	1	BI-DIRECTIONAL PURGE ADJUSTMENT VALVE
4	2	ANGLE BODY PURGE EXHAUST VALVE
5	2	PURGE PILOT VALVE
6	2	DESICCANT DRAIN PORT
7	4	STAINLESS STEEL DEFUZER
8	2	PRESSURE VESSELS
9	2	PRESSURE GUAGE
10	2	PRESSURE RELIEF VALVE (SET @ 200 PSIG)
11	2	CONTROL AIR FILTER
12	1	CONTROL AIR TUBING (1/4")
13	2	GAUGE SNUBBER
14	2	OUTLET CHECK VALVE
15	1	PURGE ADJUSTMENT VALVE
16	1	AFTER FILTER PARTICULATE TYPE
17	1	MANUAL DRAIN BALL VALVE

8.12 WD—DHL80-5000

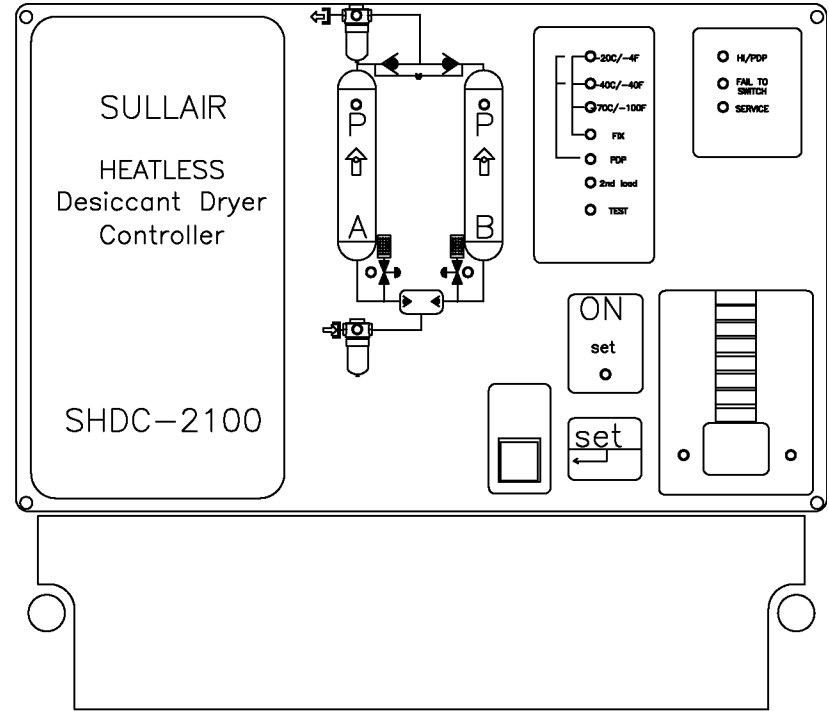
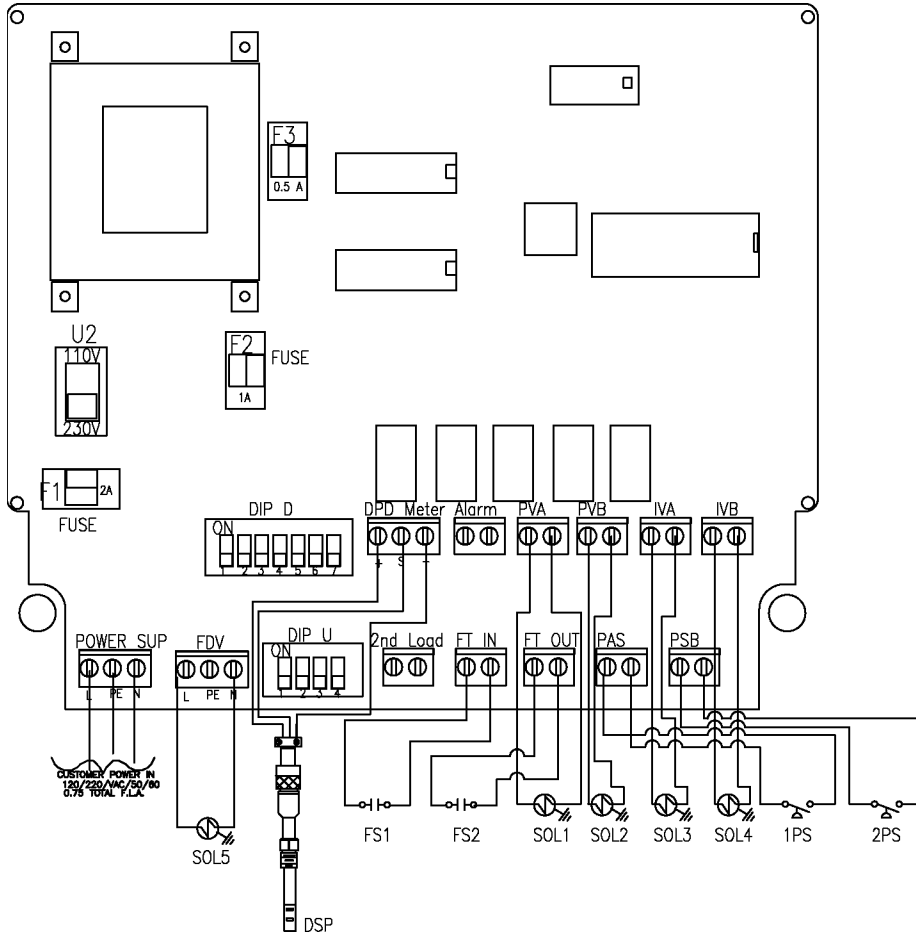

02250195-362

8.12 WD—DHL80-5000

SOL1	LEFT TOWER PURGE EXHAUST PILOT SOLENOID VALVE
SOL2	RIGHT TOWER PURGE EXHAUST PILOT SOLENOID VALVE
SOL3	LEFT TOWER INLT PILOT SOLENOID VALVE
SOL4	RIGHT TOWER INLET PILOT SOLENOID VALVE
SOL5	DRAIN SOLENOID VALVE (115-1-60 OR 220-1-50)
FS1	OPTIONAL: FILTER ELEMENT CHANGE SWITCH INLET FILTER
FS2	OPTIONAL: FILTER ELEMENT CHANGE SWITCH OUTLET FILTER
1PS	OPTIONAL: SWITCHING VALVE FAILURE RIGHT TOWER SWITCH
2PS	OPTIONAL: SWITCHING VALVE FAILURE LEFT TOWER SWITCH
DPS	OPTIONAL: DEW POINT MOISTURE SENSOR PROBE

8.13 SPARE PARTS LIST

DHL Series Desiccant Dryers	02250194-XXX	308	309	310	311	312	313	314	315	316	317	318	319	320	321	322	323	324	325	326	327	328	
Applicable Model Number	DHL-XXXX	0080	0100	0125	0150	0200	0250	0300	0400	0500	0600	0800	1000	1250	1500	2000	2500	3000	3500	4000	4500	5000	
Part Description	Part Number	Qty	Qty	Qty	Qty	Qty	Qty	Qty	Qty	Qty	Qty	Qty	Qty	Qty	Qty	Qty	Qty	Qty	Qty	Qty	Qty	Qty	
Pilot Air Filter Element	02250193-577	1	1	1	1	1	1	1	1	1	1	1	1	1	1	1	1	1	1	1	1	1	
Air -Inlet Filter Element	02250193-590	1	1	1																			
Air -Inlet Filter Element	02250193-591				1	1																	
Air -Inlet Filter Element	02250193-592						1	1															
Air -Inlet Filter Element	02250193-595								1														
Air -Inlet Filter Element	02250193-594									1	1						3	4	6	6	8	8	8
Air -Inlet Filter Element	02250193-595											1											
Air -Inlet Filter Element	02250193-597												1	1									
Air -Inlet Filter Element	02250195-196														1								
Air Outlet Filter Element	02250193-579	1	1	1																			
Air Outlet Filter Element	02250193--580				1	1																	
Air Outlet Filter Element	02250193-581						1	1															
Air Outlet Filter Element	02250193-582								1														
Air Outlet Filter Element	02250193-583									1	x						3	4	6	6	8	8	8
Air Outlet Filter Element	02250193-584											1											
Air Outlet Filter Element	02250193-585												1	1									
Air Outlet Filter Element	02250195-194														1								
Inlet Timer Drain valve	NTD-10	1	1	1	1	1	1	1	1	1	1	1	1	1	1	1							
Inlet Timer Drain valve	NTD-20																1	1	1	1	1	1	
Dryer Controller	N5620150005	1	1	1	1	1	x	1	1	1	1	1	1	1	1	1	1	1	1	1	1	1	
Tank Pressure Gauge	NPSB25-200	2	2	2	2	2	2	2	2	2	2												
Tank Pressure Gauge	NPSB40-200											2	2	2	2	2	2	2	2	2	2	2	
Lbs of Desiccant	NACF-200-316	92	115	145	175	230	290	350	430	575	750	920	1150	1450	1725	2300	2875	3450	4025	4600	5175	5750	
Pressure Relief Valve (1/4")	NMCSF25-200	2	2																				
Pressure Relief Valve (1/2")	NMCSF50-200			2	2	2	2	2															
Pressure Relief Valve (3/4")	NMCSB75-200								2	2													
Pressure Relief Valve (1")	NMCSW10-200										2	2	2										
Pressure Relief valve (1 1/4")	NMCSW12-150													2	2								
Pressure Relief Valve (1 1/2")	N19MGG-150															2	2						
Pressure Relief Valve (2")	N19MHH-150																	2	2				
Pressure Relief Valve (2 1/2")	N19MJJ																			2	2	2	
Purge Exhaust Valves (1/2")	N8290B002	2	2																				





DHL Series Desiccant Dryers	02250194-XXX	308	309	310	311	312	313	314	315	316	317	318	319	320	321	322	323	324	325	326	327	328
Applicable Model Number	DHL-XXXX	0080	0100	0125	0150	0200	0250	0300	0400	0500	0600	0800	1000	1250	1500	2000	2500	3000	3500	4000	4500	5000
Part Description	Part Number	Qty	Qty	Qty	Qty	Qty	Qty	Qty	Qty	Qty	Qty	Qty	Qty	Qty	Qty	Qty	Qty	Qty	Qty	Qty	Qty	Qty
Purge Exhaust Valves (3/4")	N8290B005			2	2																	
Purge Exhaust Valves (1")	N8290B010					2	2	2														
Purge Exhaust Valves (1.5")	N8290A020								2	2	2						4	4	2	2	2	2
Purge Exhaust Valves (2")	N8290A025											2	2	2	2	2						
Purge Exhaust valves (3")	N400300-11001466																		2	2		
Purge Exhaust valves (4")	N40040011001066																				2	2
Purge Exhaust Mufflers (1/2")	NM05	2	2																			
Purge Exhaust Mufflers (3/4")	NM07			2	2																	
Purge Exhaust Mufflers (1")	NM10					2	2	2														
Purge Exhaust Mufflers (1.5")	NM15								2	2	2								2	2	2	2
Purge Exhaust Mufflers (2")	NM20											2	2	2	2	2	4	4				
Purge Exhaust Mufflers (3")	NM30																		2	2	2	2
Air Inlet Valve (3/4")	N64360FF505	1																				
Air Inlet Valve (1")	N64360FF511		1	1	1	1																
Air Inlet Valve (1.5")	N64360FF516						1	1	1													
Air Inlet Valve (2")	N64360FF518									1	1											
Air Inlet Valve (3")	N40030011001066											2	2	2	2							
Air Inlet valve (4")	N40040011001066															2	2	2				
Air Inlet valve (6")	N400600-11001066																		2	2	2	2
Outlet Check Valve (3/4")	NUPC205-4	2																				
Outlet Check Valve (1")	NUPC205-6		2	2	2	2																
Outlet Check Valve (1.5")	NUPC205-8						2	2														
Outlet Check Valve (2")	NUPC205-9								2	2	2											
Outlet Check Valve (3")	NDR3150SSSV											2	2	2	2							
Outlet Check Valve (4")	NDR4150WSSSV															2	2	2				
Outlet Check Valve (6")	NDR6150WSSSV																		2	2	2	2
Purge Exhaust Solenoid Valve (1/8")	NSC8356A001V	2	2	2	2	2	2	2														
Purge Exhaust Solenoid Valve (1/4")	NSC8320G184								2	2	2	2	2	2	2	2	2		2	2	2	
Inlet Solenoid Valve	NSC8320G184											2	2	2	2	2	2	2	2	2	2	2
Gauge Pressure Snubber	NPS-25	2	2	2	2	2	2	2	2	2	2	2	2	2	2	2	2	2	2	2	2	2
1/4" Control air Tubing	NUP-44-GN	10FT	10FT	10FT	10FT	10FT	10FT	15FT	15FT	15FT	15FT	20FT	20FT	20FT	20FT	20FT	20FT	20FT	30FT	30FT	30FT	30FT

NOTES



SULLAIR[®]

Always air. Always there.

WWW.SULLAIR.COM

SULLAIR CORPORATION

3700 East Michigan Boulevard • Michigan City, Indiana, 46360 U.S.A.
Telephone: 1-219-879-5451

Printed in the U.S.A.

Specifications subject to change
without prior notice.

E11EP